

METAL CARBONYLS AND THE FISCHER-TROPSCH REACTION
BETWEEN HYDROGEN AND CARBON MONOXIDE.

THESIS

submitted to the

UNIVERSITY OF GLASGOW

for the Degree of

DOCTOR OF PHILOSOPHY

by

J.R. Moody, B.Sc.

December 1958.

ProQuest Number: 13850364

All rights reserved

INFORMATION TO ALL USERS

The quality of this reproduction is dependent upon the quality of the copy submitted.

In the unlikely event that the author did not send a complete manuscript and there are missing pages, these will be noted. Also, if material had to be removed, a note will indicate the deletion.



ProQuest 13850364

Published by ProQuest LLC (2019). Copyright of the Dissertation is held by the Author.

All rights reserved.

This work is protected against unauthorized copying under Title 17, United States Code
Microform Edition © ProQuest LLC.

ProQuest LLC.
789 East Eisenhower Parkway
P.O. Box 1346
Ann Arbor, MI 48106 – 1346

ACKNOWLEDGMENTS.

I wish to record my sincere thanks to Dr J. Bell for his friendly supervision and his constant encouragement and interest throughout this work.

I am also grateful to the Department of Scientific and Industrial Research for a Maintenance Allowance held during the first year of the research.

Summary.

A study has been made of the synthesis of nickel carbonyl from carbon monoxide and nickel. No evidence was found to support the previous conclusions of Mittasch that the reaction is of second order with respect to carbon monoxide, but, on the contrary, the reaction appears to be either zero or first order with respect to the monoxide, depending on the activity of the nickel involved.

Attempts to correlate this synthesis with the Fischer-Tropsch synthesis of hydrocarbons by calculating the approximate rate of carbonyl synthesis at 190°C. and comparing with the experimentally determined rate of a Fischer-Tropsch reaction at this temperature, suggested that it was possible for the two reactions to have a common intermediate.

Qualitative experiments showed that during the hydrocarbon synthesis there is no nickel carbonyl in the effluent gas, although when argon is substituted for hydrogen and all other conditions are the same, nickel carbonyl is formed.

C^{14} tracer investigations showed that there is no exchange of C^{14} between hydrocarbons and labelled carbon/

carbon monoxide or labelled nickel carbonyl at 190°C. Addition of C¹⁴ labelled nickel carbonyl to the inflowing gas reactants of a Fischer-Tropsch reaction and analysis of the effluent gas showed that nickel carbonyl, or some stage before the final step in its decomposition, participates in the Fischer-Tropsch reaction, although no evidence was obtained as to the identity of this intermediate.

For the purposes of this tracer work, an accurate method of estimating the C¹⁴ content of solid materials, and also a very useful end-window gas counter have been developed.

INDEX

	Page
Acknowledgments	
Summary	
<u>Chapter I.</u> Introduction	1
I.1. Outline of programme	8
<u>Chapter II.</u> A study of the kinetics of formation and decomposition of nickel carbonyl	10
II.1. Introduction	10
II.2. The synthesis of nickel carbonyl	15
II.2.a. General procedure	15
II.2.b. Preparation and reproducibility of the nickel	19
II.2.c. Synthesis at 35°C. - "slow" reaction	20
c.1. Pure carbon monoxide	20
c.2. Argon/carbon monoxide mixtures	22
c.3. Dependence on flow rate	25
c.4. Effect of argon and of hydrogen	25
c.5. Extension to lower pressures of carbon monoxide	27
c.6. Summary	28
II.2.d. Synthesis at 35°C. - "fast" reaction	31
d.1. Pure carbon monoxide	31
d.2. Effect of varying flow rate	31
d.3. A new approach	32

	Page
II.4. Correlation of the synthesis of carbonyl with the Fischer-Tropsch synthesis	62
4.a. Synthesis of nickel carbonyl at 35°C. from a nickel Fischer-Tropsch catalyst	62
4.b. Synthesis of nickel carbonyl under Fischer-Tropsch conditions	62
4.c. The rate of synthesis of nickel carbonyl at 190°C.	64
4.d. Nickel carbonyl decomposition in the presence of a nickel catalyst	66
II.5. Summary	67
<u>Chapter III.</u> Investigations using C ¹⁴ tracer	69
III.1. Introduction	69
III.2. Preparation of labelled materials	73
III.3. Exchange reactions	73
3.a. Between carbon monoxide and methane	73
3.b. Between nickel carbonyl and methane	74
3.c. Between carbon monoxide and nickel carbonyl	75
III.4. Summary	77
III.5. Tracer investigation of the Fischer- Tropsch synthesis	78
III. 6. Final conclusions	79
<u>Chapter IV.</u> The estimation of C ¹⁴	81
IV.1. Introduction	81

	Page
IV.2. Carbon monoxide as a gas filling	82
2.a. The counting tube	82
2.b. Filling with carbon monoxide	83
2.c. Carbon monoxide as a minor constituent	84
IV.3. Solid counting	88
3.a. Introduction	88
3.b. Homogeneous active barium carbonate	88
3.c. Preparation of counting surface	89
c.1. Suspensions	89
c.2. Pastes	90
c.3. Filtering	90
c.4. Pressing	91
3.d. Extension to smaller amounts	94
d.1. Reproducibility	94
d.2. Variation of counting rate with the percentage active material	98
IV.4. End-window gas counting	102
4.b. The counter filling	103
4.c. Calibration	105
<u>Chapter V.</u> Experimental details	108
V.1. The apparatus and its manipulation	108
1.a. The gas circulating apparatus	108
a.1. Circulating pump	109
a.2. Exit ballast bulb	112

	Page
V.1.a.3. Flowmeter	112
a.4. Reaction chamber	113
a.5. Cold traps	116
a.6. Entrance ballast bulb	117
a.7. High vacuum line	117
a.8. Gas reservoir	118
a.9. Gasometer	118
a.10. Gas synthesis and purification line	121
a.11. Decomposition tube	122
a.12. Use of the cycle	122
1.b. Apparatus for studying the thermal decomposition of nickel carbonyl	124
1.c.1. Apparatus for C ¹⁴ tracer work	127
1.c.2. Assay of C ¹⁴ containing gas	129
V.2. Preparation and purification of materials	130
2.a. Carbon monoxide	130
2.b. Argon	131
2.c. Hydrogen	131
2.d. Nitrogen	131
2.e. Nickel formate	131
2.f. Nickel carbonyl	132
2.g. Nickel Fischer-Tropsch catalyst	133
2.h. Standard nickel solution	134
2.i. Homogeneous C ¹⁴ active barium carbonate	134

	Page
V.2.j. Radioactive carbon monoxide	135
2.k. Radioactive carbon dioxide	136
2.l. Methane	136
2.m. Ammoniacal cuprous chloride solution	136
V.3. Estimation of nickel	137
V.4. Experimental results	139
4.a. Nickel carbonyl decomposition	139
4.b. C ¹⁴ exchange experiments	140
b.1. Carbon monoxide and methane	140
b.2. Nickel carbonyl and methane	140
b.3. Carbon monoxide and nickel carbonyl	140
4.c. Estimation of C ¹⁴	141
c.1. Suspensions	141
c.2. Pastes	141
c.3. Filtering	142
Appendix	143
Bibliography	145

METAL CARBONYLS AND THE FISCHER-TROPSCH REACTION BETWEEN HYDROGEN AND CARBON MONOXIDE

I. INTRODUCTION

Although the catalytic hydrogenation of carbon monoxide to Methane was first achieved by Sabatier and Senderens in 1902¹ it was not until 1922-26, when Fischer and Tropsch published papers on the reduction of carbon monoxide by hydrogen to higher hydrocarbons,² that a real interest developed in this reaction because of its new-found economic importance. Since then innumerable investigations have been undertaken to further the technical development of the process by improving the catalysts, ratio of reactants, pressures, temperatures and flow rates involved and a differentiation was made between reactions at higher pressures which gave oxygen-containing compounds and reaction at lower pressures which gave rise to hydrocarbons. More recently research into the mechanism of the latter reaction (the Fischer-Tropsch reaction) has become more active as evidence was gradually produced that the original hypothesis of Fischer and Tropsch failed to fit all the observations.³

Because this original theory postulated the intermediate formation of a metallic carbide, it has been named the carbide theory and it was more fully formulated in 1932 by Fischer and Koch⁴ as follows. After carbon monoxide is chemisorbed on the active metal surface, the carbon-oxygen bond is broken by reduction with either hydrogen or further carbon monoxide to give water or carbon dioxide respectively, leaving a carbon atom bound to the surface, thus forming what is in effect a surface carbide. More hydrogen then converts this carbide to the radicals CH, CH₂, and CH₃, which then polymerise and desorb to give a wide variety of hydrocarbons.

The following considerations gave evidence for this theory:-

- 1) During the synthesis the metal catalyst (nickel, cobalt or iron with carrier and promoter) is gradually converted into metallic carbide.
- 2) Metallic carbides give hydrocarbons on acidification. This is a common property, e.g. aluminium carbide gives methane, calcium carbide gives acetylene - similarly iron carbide gives methane and higher hydrocarbons.₅

- 3) The above mechanism explained in part how cobalt catalysts could give water and yet iron catalysts give carbon dioxide as the principal oxygenated product.
- 4) Since the higher hydrocarbons would take longer to form, in effect they would be longer in contact with the catalyst before desorption and hence would be more fully hydrogenated than those of lower boiling point. This is exactly what is observed.
- 5) Two stage synthesis over a cobalt catalyst with preliminary passage of carbon monoxide followed by passage of hydrogen gives rise to methane. This is hydrogenation of cobalt carbide made by the action of carbon monoxide on cobalt at the synthesis temperature.⁶ However, iron carbides are apparently immune to hydrogenation under Fischer-Tropsch conditions.

The catalysts used in a Fischer-Tropsch synthesis eventually become inactive due to an accumulation of wax on the surface. Removal by solution in a solvent, and examination, showed that the wax consisted of high boiling point hydrocarbons and further work on the removal of the wax by hydrogen at 210^o C showed that the chain length/

FIGURE I.

CRAXFORD'S VIEW OF THE CARBIDE MECHANISM.

1) Carbon monoxide reacts with the metal surface.



2) Chemisorbed CO is reduced in two stages.

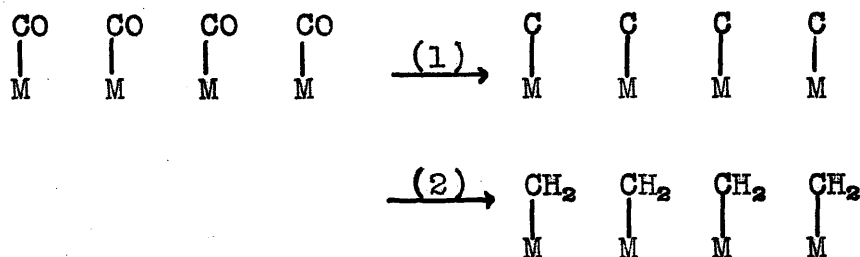

3) The methylene groups polymerise.

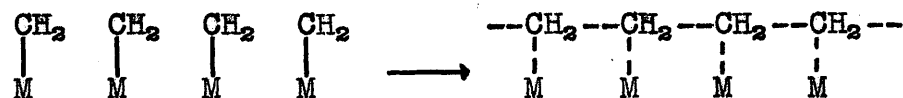

4) The polymer "cracks" to give volatile hydrocarbons.

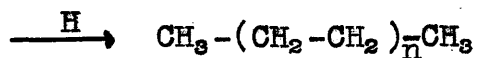

length distribution curve for the products had the same shape as the distribution curve for the actual Fischer-Tropsch synthesis products⁷. This observation led to an alternative to the carbide theory in which the first steps were the same but the final step differed in that a large polymer of methylene groups actually existed on the surface and this polymer was "cracked" by the action of the hydrogen of the synthesis gas giving rise to a mixture of hydrocarbons in a similar manner to the hydrocracking of the wax. It was further postulated that the hydrogen must be chemisorbed before it could crack the giant molecule and so if the number of chemisorbed hydrogen atoms were small the fragments breaking off would be large, whereas if chemisorbed hydrogen were abundant the polymer would be converted mostly into methane. This idea was supported by the work of Craxford and Rideal⁸, who, using the para-ortho conversion of hydrogen as an indicator for chemisorbed hydrogen, showed that conversion took place under conditions favourable for methane synthesis but was apparently prevented when larger hydrocarbons were being produced.

An immediate criticism of the first carbide theory was made by Elvins and Nash⁹ who pointed out that, as it stood, there was no explanation of how oxygenated hydrocarbons could be formed and yet they had isolated such/

such compounds during a Fischer-Tropsch synthesis. They therefore stated that the intermediate should be an oxygen containing compound and that the hydrocarbons were formed by the secondary process of dehydration and hydrogenation but a possible explanation was later offered by Craxford and Rideal⁸ who suggested that the oxygenated hydrocarbons were formed by the incorporation of carbon monoxide molecules into the hydrocarbon from the second adsorbed layer on the catalyst - a view that was substantiated by the observation that more oxygenated compounds were formed as the pressure of the gas in the reaction chamber was raised, i.e. as the probability of formation of a second layer rose. However, in more recent years evidence at variance with the carbide theory has come to light and it has been established that metallic carbides do not take part in the synthesis at least in so far as the bulk material is concerned, although it was not possible to prove that surface carbide took no part especially if the catalyst surface was irregular as has been shown.¹⁰ The observations which brought about this change of viewpoint made use of many different techniques as can be seen from the following summary.

- 1) Kinetics. It was found that the velocity of synthesis was greater than the velocity of/

of carbide formation on iron, nickel and cobalt catalysts¹¹ and that the presence of substantial amounts of cobalt carbide severely impaired the ability of a cobalt catalyst to form hydrocarbons.¹²

- 2) X-rays. Both spent and freshly prepared catalysts contained cobalt in a cubic form but hydrogenation of a cobalt carbide gave a hexagonal form of cobalt.¹³
- 3) Thermodynamics. When calculated equilibrium constants for the synthesis of n-paraffins (C₁ to C₄) were compared with those from yields obtained it appeared that these products could not have been formed by reduction of iron carbide.¹⁴
- 4) C¹⁴ Tracer Investigation. After iron and cobalt catalysts were carburised with carbon monoxide containing C¹⁴O the rate of appearance of C¹⁴ in the products of a subsequent Fischer-Tropsch synthesis suggested that hydrogenation of carbide was slight but it could not be completely ruled out that carbide was an intermediate if only a small part of the surface were involved.¹⁵

After addition of labelled methane to the synthesis reactants, examination of the products showed that the methane was not incorporated in the reaction.¹⁵

When methyl-labelled and methylene labelled ethyl alcohol were added to synthesis gas passing over an iron catalyst there resulted negligible activity in the/

the methane produced but high activity in the $C_5 - C_{10}$ range suggesting that either ethyl alcohol or its adsorption complex behaves as a Fischer-Tropsch intermediate and, furthermore, analysis of the C_9 product showed that chain addition was to the alpha-carbon of the complex.¹⁶

Later work gave confirmation by extending this to n- and iso- propyl and butyl alcohols¹⁷ although other workers gave conflicting evidence.¹⁸

Addition in separate experiments of labelled carbon dioxide, methyl alcohol, and formaldehyde to the synthesis gas before passing over the catalyst, showed that neither carbon dioxide nor formaldehyde took part in the reaction, and that methyl alcohol or its adsorption complex could initiate but not propagate hydrocarbon chain formation, although its ability for initiation was much less than that of ethyl alcohol.¹⁹

The inevitable conclusion from the foregoing and especially from the results of the powerful tracer technique is that the idea of a carbide intermediate is untenable and carbide must be supplanted by an oxygen containing complex analogous to an adsorbed alcohol which gives rise to a long chain oxygenated hydrocarbon, subsequently reduced/

by dehydration and hydrogenation. Examination of the isomeric distribution of the resultant hydrocarbons²⁰ shows that the propagation must take place by addition of a C₁ unit, but the nature of this intermediate is as yet uncertain.

Since optimum conditions for the Fischer-Tropsch synthesis prevail at pressures just below those at which the tendency towards formation of metal carbonyls becomes large²¹ and moreover since it is known that the OXO reaction (i.e. hydroformylation of a double bond in a hydrocarbon by reaction with hydrogen and carbon monoxide) is homogeneously catalysed by metallic carbonyls,²² it seems likely that a study of metal carbonyls would offer a profitable way of obtaining information about the complexes involved in the hydrocarbon synthesis. It is remarkable that in spite of the intensive work done on the mechanism of the synthesis no attempt has been made to investigate the possibility of metallic carbonyls being involved either in bulk or as a surface intermediate.

Such an attempt was the aim of the present work.

Outline of the Programme.

The main project was a variation of the tracer experiments outlined previously, viz, to pass hydrogen and carbon monoxide together with about 1% of C¹⁴ radioactive nickel carbonyl over a metal catalyst and to determine a C¹⁴ balance to see whether the carbonyl had taken part or not.

Nickel carbonyl (and nickel catalyst) was used because of the relative ease of synthesis of the radioactive form.

This was supplemented with a study of the carbonyl whereby it was hoped to establish whether bulk carbonyl could exist as such during the Fischer-Tropsch synthesis and whether there was any relationship between the kinetics of formation of nickel carbonyl and the kinetics of hydrocarbon synthesis over a nickel catalyst.

II. A STUDY OF THE KINETICS OF FORMATION AND DECOMPOSITION OF NICKEL CARBONYL.

I. Introduction.

If the rate of synthesis of hydrocarbons in a Fischer-Tropsch process is greater than the rate of synthesis of nickel carbonyl under the same conditions of pressure ($\frac{1}{2}$ atmosphere of carbon monoxide) and temperature (200°C) then it is quite obvious that nickel carbonyl as a bulk material can not be an intermediate in the synthesis of hydrocarbons. However, when the probability of a five body collision is considered it is most likely that the synthesis of the carbonyl takes place in several consecutive steps and it is quite feasible that some intermediate in this synthesis is also an intermediate in the Fischer-Tropsch synthesis. For example, the synthesis of the carbonyl could take place in four steps.

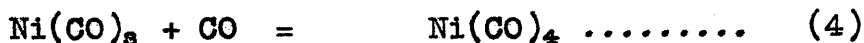
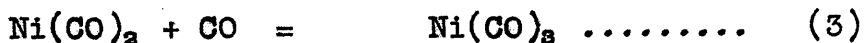
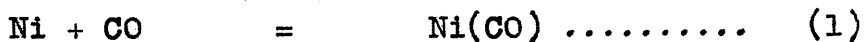

and the Fischer-Tropsch reaction could follow the sequence:-

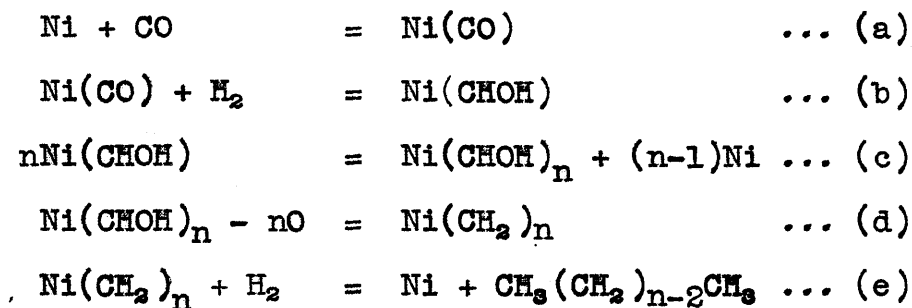

These two hypothetical reaction schemes have the same initial step, the formation of Ni(CO), and if this stage were rate determining for both processes then they would show the same kinetic properties and hence a comparison of the kinetics of synthesis of nickel carbonyl and of the Fischer-Tropsch synthesis might give rewarding results and could perhaps show whether some steps in the former can or can not be applicable to the latter.

It is worth while noting here that all theories so far published concerning the mechanism of the Fischer-Tropsch synthesis automatically assume that the first step in the process is the formation of Ni(CO) surface compound although there is little experimental justification for such an intermediate apart from the fact that it is "obvious".

On the other hand it is claimed by Mittasch²⁸ that nickel carbonyl is formed via Ni(CO)₂ and that the synthesis is second order with respect to carbon monoxide concentration/

concentration, i.e. that

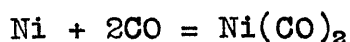

is the rate determining step.

This would suggest that the Fischer-Tropsch reaction might incorporate $\text{Ni}(\text{CO})_2$ as its first intermediate and give rise by hydrogenation to a C_2 unit for chain initiation and propagation. Moreover, this idea is supported by the previously mentioned C^{14} tracer work of Kummer and Emmett who showed that the complex formed by ethyl alcohol could initiate chain building much better than that of methyl alcohol although their evidence also requires a C_1 propagation unit which is different from the methyl alcohol adsorption complex.

Reference to the literature shows that there has been neither confirmation nor contradiction of the results of Mittasch from any source and his original paper "The Chemical Dynamics of Nickel Carbonyl" gives the impression that the kinetic study was complicated by experimental difficulties and that he was doubtful of the validity of his conclusions for he actually gives an example of how his data for the synthesis of nickel carbonyl could give rise to a fourth order dependence on carbon monoxide pressure. Furthermore, his conclusion that the reverse reaction, nickel carbonyl decomposition, is a unimolecular process can be simply shown to be mistaken/

mistaken since it is a recognised procedure to store nickel carbonyl under carbon monoxide to prevent spontaneous decomposition²⁴ and therefore the decomposition must be dependent in some way upon the pressure of the carbon monoxide in the system. Further proof that this is not a unimolecular reaction comes from the work of Bawn²⁵ (confirmed later by Tonosaki and Suginuma²⁶) who showed that the decomposition was mostly homogeneous but partly heterogeneous and that the following expression fitted well his data for both types of reaction.

$$\frac{dx}{dt} = \frac{k [\text{Ni}(\text{CO})_4]}{1 - k_1 [\text{CO}]}$$

where k and k_1 are constants and the expression dx/dt refers to the rate of production of carbon monoxide (or the loss of nickel carbonyl) in the system.

In view of the possibility that Mittasch may have been wrong also in his conclusions on the kinetics of the synthesis of nickel carbonyl, since no verification has been published, it was therefore felt worth while to investigate the reaction afresh.

Extrapolation of the data produced for the equilibrium constant at various temperatures of the system

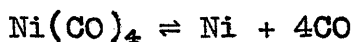

by Mittasch and also by Montgomery and Tomlinson²⁷ whilst not in agreement, predict that under the conditions of a Fischer-Tropsch synthesis, the rate of decomposition of nickel carbonyl is vastly in excess of the rate of its/

EXTRAPOLATION OF K_p AGAINST TEMPERATURE DATA

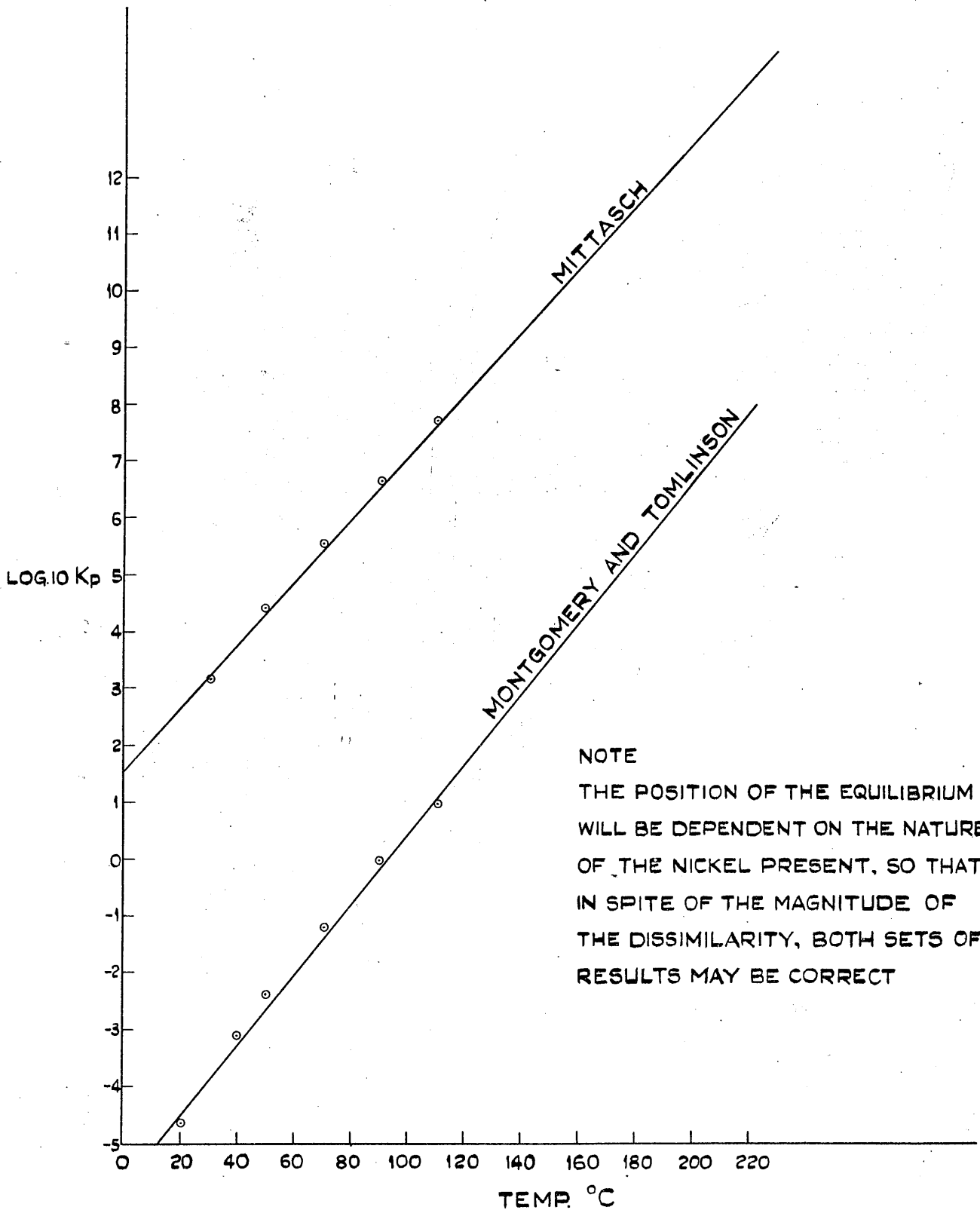

FIGURE 2

its synthesis and that the maximum value attainable for the vapour pressure of the carbonyl in the effluent gas will be 10^{-15} atmospheres according to Mittasch and 10^{-9} atmospheres according to Montgomery and Tomlinson. This value is obtained by substituting $\frac{1}{2}$ atmosphere for the concentration of the carbon monoxide and the extrapolated value for K_p at 200° (see opposite) in the expression

$$K_p = \frac{[CO]^2}{[Ni(CO)_4]}$$

and evaluating $Ni(CO)_4$.

Such a quantity is in fact immeasurable when using normal simple experimental methods and therefore there is no likelihood of making a direct measurement of the rate of carbonyl synthesis under these conditions, and furthermore it is the absolute rate of formation and not the effective rate which is desired and such a measurement would be impossible without evaluating also the rate of decomposition and the position of the system as regards equilibrium. Use must therefore be made of kinetic measurements at various lower temperatures where the difficulties caused by the back reaction are negligible, by extrapolating as an Arrhenius plot, the observed rates to the desired temperature of $200^{\circ} C$. Comparison of this calculated rate with the rate of a Fischer-Tropsch synthesis will show whether the two synthesis have anything in common and moreover if the kinetic study of the/

APPARATUS FOR STUDYING $\text{Ni}(\text{CO})_4$ SYNTHESIS

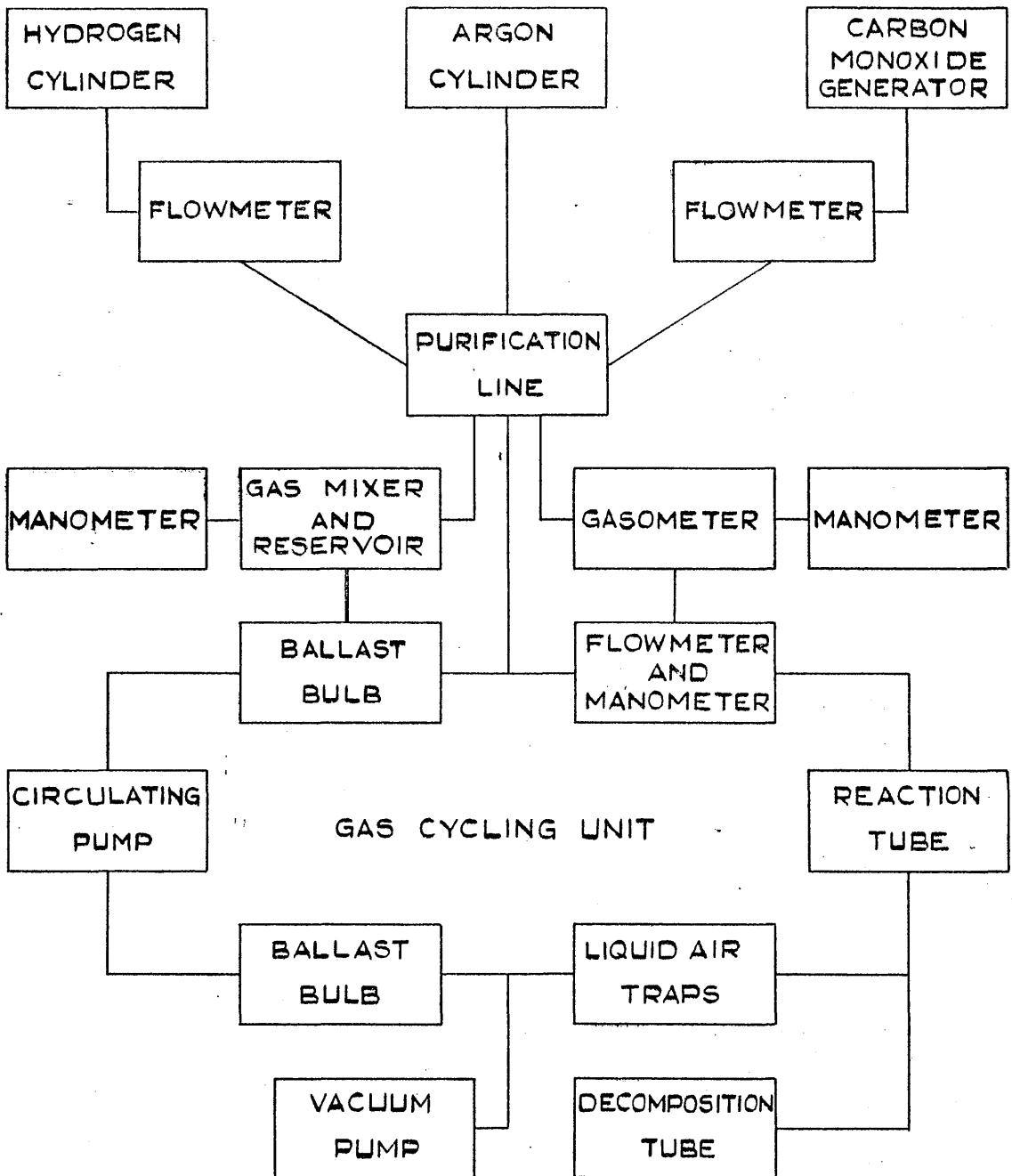

the carbonyl leads to an understanding of the mechanism of its synthesis, then it will be possible to state whether certain steps are possible or impossible in the Fischer-Tropsch synthesis and perhaps to substantiate the view that Ni(CO) or Ni(CO)_2 is the primary stage.

As stated above, the equilibrium figures available postulate that the maximum content of the exit gas from a hydrocarbon synthesis over a nickel catalyst is 10^{-9} atmospheres. This value is inconsistent with the report that a nickel catalyst can not be used in a Fischer-Tropsch synthesis with pressures of reactants greater than atmospheric because of the formation of nickel carbonyl.^{28, 29, 30} Therefore it would seem probable that either the equilibrium figures are erroneous or the nickel catalyst for the Fischer-Tropsch process is an extremely efficient source for nickel carbonyl or else the hydrogen present plays a part by affecting the stability of the carbonyl preventing decomposition perhaps by formation of a carbonyl hydride or by speeding up the synthesis. In any case it would appear worth while investigating whether the presence of hydrogen has any effect on the kinetics of synthesis or of decomposition of nickel carbonyl.

II.2 The synthesis of nickel carbonyl.

a) General Procedure.

Since the apparatus used in this section of the work (shown opposite as a block schematic diagram) is fully/

fully described in the experimental section only the general principles and manipulation are described here.

The reacting gas or gas mixture was circulated by means of a pump round a closed cycle in which it passed through a flowmeter, then into a constant temperature reaction chamber containing the active solid nickel, then via several cold traps for removing the products and back to the flowmeter again. Since all the products were condensed out, and the system had a fixed volume, there was subsequently, as the reaction progressed, a gradual drop in the pressure of the gases within the apparatus which could be followed by manometric measurements. From pressure readings at known time intervals, the variation of pressure (P) with time (t) could be found, and since the rate of reaction is directly proportional to the rate of loss of pressure ($-dP/dt$), the dependence of the rate of reaction upon pressure of the reacting gas, and hence the kinetics of the synthesis, can be readily derived.

Such an operation has the attractions that the only experimental readings necessary are made quite simply with reasonable precision, viz:- Time by stopwatch, and pressure by cathetometer, although complicating factors do arise as outlined below together with the steps taken to surmount them.

- 1) The stroke action of the pump gave rise to pulses in the flow of gas round the system. These surges could be/

be prevented by placing on both sides of the pump a large ballast bulb which smoothed the stream of gas but which naturally, by increasing the effective volume of the system fourfold, had a marked effect on the rate of drop in the pressure. The bulbs were attached in such a manner that they could be isolated by using by-passes and a much faster rate of fall of pressure could then be obtained, but only at the expense of reintroducing spasmodic gas flow.

2) With the exception of the reaction zone and the cold traps, the major part of the apparatus was at room temperature which fluctuated in the normal manner, necessitating a temperature reading when the pressure measurement was made. All pressures were corrected for temperature deviations to a standard temperature (generally $20.0^{\circ}\text{C}.$).

3) The pump employed to produce flow had a constant volume stroke and hence, as the pressure within the apparatus varied, so also did the resultant rate of flow unless the rate of stroke was altered suitably - a method of compensation which was at best rather crude. In actual practice this complication was not serious since in runs where the flow rate was critical there was no need to maintain a constant value, provided the change in flow rate was regular and predictable.

4) The construction of the pump imposed a maximum pressure range upon the runs of between 800 and 400 m.m. of mercury. Where it was desirable to work with pressures of carbon monoxide less than 400 m.m. it was essential to have present a diluent gas such as argon to bring the pressure of the system above 400 m.m. and in this way it was possible to use carbon monoxide at pressures down to zero.

5) In the synthesis of nickel carbonyl, since the active nickel metal present does not act merely as a catalyst but actually participates in the reaction, the possibility is quite large that the rate of reaction will be dependent on the amount of active metal present, a quantity which might well lessen with time thus adding another variable component to the system. Also the reaction may be affected by poisoning of the nickel by impurities and hence the plot of pressure against time would give a false picture of the progress of the true synthesis.

It was therefore standard practice to raise the pressure of the system at the end of a run and to repeat part of the run. Only if the two resultant pressure-time curves were identical could the run be considered satisfactory.

This susceptibility of the nickel to loss of activity caused the greatest difficulty in the work on the synthesis of nickel carbonyl, there being no apparent/

apparent method of avoiding break downs in the runs. In fact throughout this entire research this compound proved to be a somewhat unpredictable substance to handle - for instance, distillation even in a vacuum system was never once accomplished without some decomposition occurring. It seems highly probable that the reason for the lack of really detailed research and the apparent incompleteness of, and inconsistencies in, published data on this compound is its essential instability.

b) Preparation and Reproducibility of the Nickel.

The active nickel was prepared in situ by the thermal decomposition of a weighed amount of nickel formate with continual removal of the gaseous products formed either by means of an applied vacuum or by a stream of pure hydrogen. Full details of this preparation are given in the experimental section together with the preparation of nickel formate (commercially available nickel formate (B.D.H.) was found unsuitable because of the presence of ammonium salts which poisoned the reaction.)

Unfortunately the reproducibility of the activity of the nickel from specimen to specimen as measured by the rate of its subsequent reaction with carbon monoxide gas was very poor and even although precautions were taken as far as possible to ensure that all the variable factors were kept as constant as possible, it was only by/

by coincidence that the activity of a nickel specimen was identical with any previous one.

Nevertheless it was noticeable that the catalysts fell into two distinctive groups, those that were relatively inactive and those that were highly active, and further, that the majority of the first type resulted from thermal decomposition under vacuum, whereas the more active class were generally, but not always, prepared in a hydrogen stream. This rather suggests that some of the products of the decomposition (e.g. water or carbon dioxide) can poison the resultant nickel (e.g. by the formation of nickel-oxygen bonds) and that this is less likely to happen if hydrogen is present to counteract it by reduction, but the extent of poisoning varied from one preparation to the next because of slight variations in the temperature and other conditions.

It is proposed to classify the following experiments according to whether they are "fast" or "slow", and to deal with each type separately starting with those of relatively inactive catalyst.

c) Synthesis of nickel carbonyl at 35°C. - "slow" reaction.

c.1. Pure carbon monoxide.

Nickel was prepared in situ and the reaction chamber isolated under vacuum whilst the remainder of the cycling apparatus was filled to above atmospheric pressure with/

RATE OF SYNTHESIS OF NICKEL CARBONYL AT 35°C.

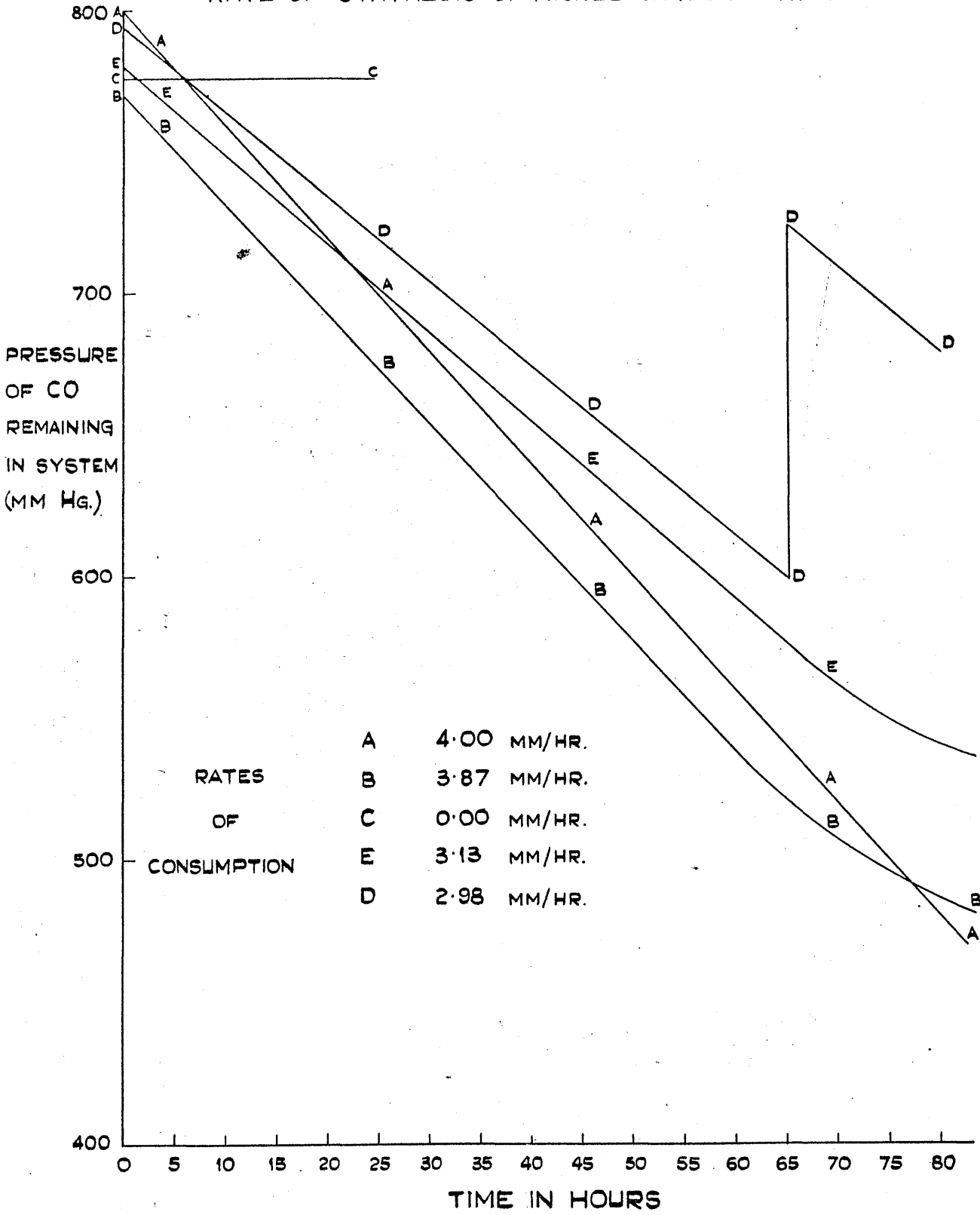

FIGURE 3

with pure carbon monoxide (for preparation and purification see experimental section.) By opening the appropriate taps to allow the gas into the reaction chamber, starting the circulation pump and taking an immediate reading of pressure, a zero time value of the pressure of the carbon monoxide could be found (P_0). Since the nickel carbonyl formed was removed by passing the effluent gas from the reaction chamber through two traps immersed in liquid oxygen, the rate of synthesis was directly proportional to the rate of carbon monoxide consumption, i.e. to the rate of drop of pressure within the system; this was conveniently followed by making pressure measurements at noted time intervals after zero time. No nickel mirror was deposited on heating the glass connection from the traps to the pump ballast bulb, even when the glass was almost at its softening point, showing that the traps were 100% efficient.

Throughout the following work, the reaction chamber was maintained at 35^o C. by means of a jacket of the vapour of boiling diethyl ether.

The reaction was slow, the internal pressure of the system taking four days to fall from 800 to 400 mm. of mercury, as can be seen from the plot of pressure against time, (Figure 3, line A), where the time axis is measured in units of hours. The resultant straight line suggests that the reaction is kinetically of zero order.

By raising the pressure of the carbon monoxide back up to 770 mm. and repeating the run, it was demonstrated that the nickel had remained constant in activity, since this repeat gave a straight line (line B, figure 3) for the plot of P_{CO} against t , with the same slope as the previous line A, although deviation became noticeable below 530 mm., where the rate of reaction slowed down. A further repeat showed that the nickel was now inactive as regards nickel carbonyl synthesis (line C).

The eventual loss of activity in the nickel is not surprising when it is considered that the rate of reaction was constant for the consumption of approximately 6 litres of carbon monoxide at N.T.P., corresponding to the removal of over 3.5g. of nickel from the reaction bed, and yet the original mass of nickel in the system was only about 7g.

Two repeats of this experiment with fresh nickel in each case gave similar results, the plot of pressure against time being linear, but the slopes were distinctly different (lines D and E, figure 3), although the same weight of the same starting material had been used, and the temperature of reaction had been the same as for line A.

c.2. Carbon monoxide mixtures with argon.

Since the criticism may be levelled that the experimental range (P_0 to $\frac{1}{2}P_0$) of the previous type of run was/

was too limited to give unambiguous conclusions as to the kinetics of the process involved, runs were made in which the consumption of carbon monoxide was extended to from P_0 to a small fraction of P_0 by adding argon to the system to make the total pressure at the end of the run more than 400mm. of mercury, whilst the carbon monoxide pressure was less than 100mm. Argon was used as a diluent since as an inert gas it was less likely to interfere with the reaction than other gases, e.g. nitrogen might well adsorb on the active sites of the nickel, block the approach of carbon monoxide and hence prevent the desired reaction.

The reservoir bulbs were filled with a mixture of argon and carbon monoxide by admitting the monoxide to a pressure P_1 and topping up with argon to a suitable pressure P_2 , giving a carbon monoxide to argon ratio of $P_1/(P_2 - P_1)$. Preliminary experiments gave results which were erratic, suggesting that the two gases were not mixing properly in the reservoir even on standing overnight. The reservoir consisted of four 5-litre bulbs joined together by a fairly narrow neck piece which presumably acted as a constriction limiting natural diffusion. To counteract this effect a Topley pump was attached to the bulbs whereby the gas was converted to homogeneity by circulation for two hours.

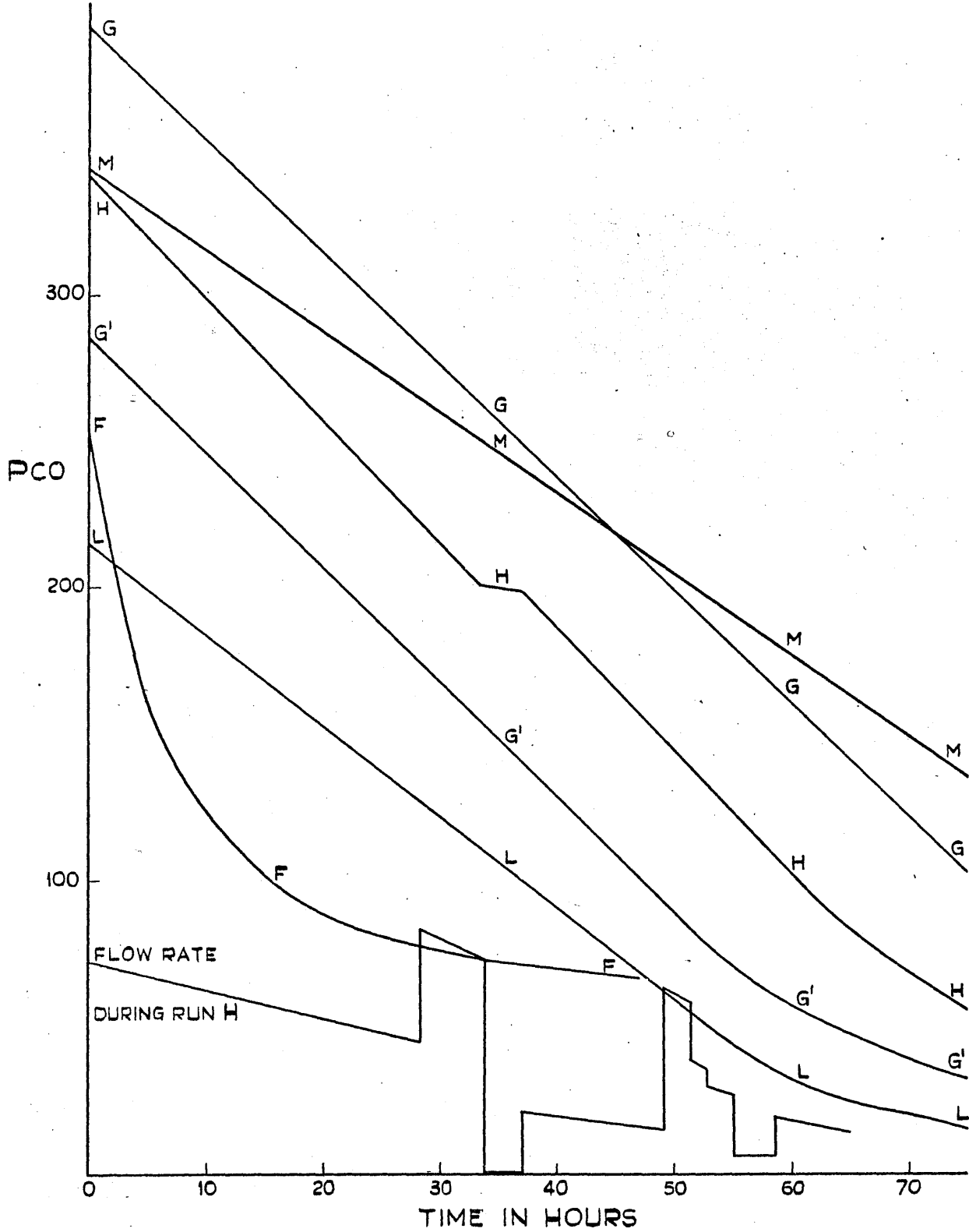

FIGURE 4

This uniform mixture was then circulated over a freshly prepared batch of nickel in precisely the same manner as in the previous experiments, and the variation of pressure with time was followed.

The results for this experiment and for several repeat runs, each made with a different nickel specimen are shown in figure 4 as the lines F, G, H, L and M. It is worth noting that the plots G, H, L and M are linear until a small fraction of the initial pressure of carbon monoxide is left, and the slope is reproducible for each individual nickel specimen but not from one to the other. Run F was the first occasion on which the nickel produced by thermal decomposition of formate under a vacuum was of the highly active type and will be discussed later. Otherwise the conclusion is that the reaction is zero order with respect to carbon monoxide at least until the pressure of this gas is less than a hundred millimetres of mercury. The deviations at lower pressures could be caused by :-

- 1) The reaction becoming dependent on the partial pressure of the carbon monoxide in the reaction vessel.
- 2) The flow rate becoming too small to bring carbon monoxide into the reactor as rapidly as it is consumed, and hence the reaction becomes flow rate dependent.

- 3) Lack of homogeneity in the circulating gases, so that the pressure of carbon monoxide in the gas passing over the nickel is less than its calculated value.

c.3. Dependence on flow rate.

During all the previous runs, as the rate and the volume of the stroke of the circulating pump was maintained constant, the flow rate produced gradually decreased in proportion with the total pressure within the system. To ensure that this variation in rate of flow was not concealing some effect of the carbon monoxide pressure on the reaction rate, the flow rate in run H was deliberately changed at various points of time by altering the speed of stroke of the pump, and then the rate of reaction was compared with the rate of flow of gas. But, as can be seen from figure 4, (page 24), there was no interdependence provided the flow was not reduced to an insignificant value.

c.4. Effect of argon and of hydrogen.

The possibility of argon affecting the activity of the nickel by adsorption on active sites was investigated by making a run in two parts, in the first/

EFFECT OF ARGON AND HYDROGEN ON REACTION RATE

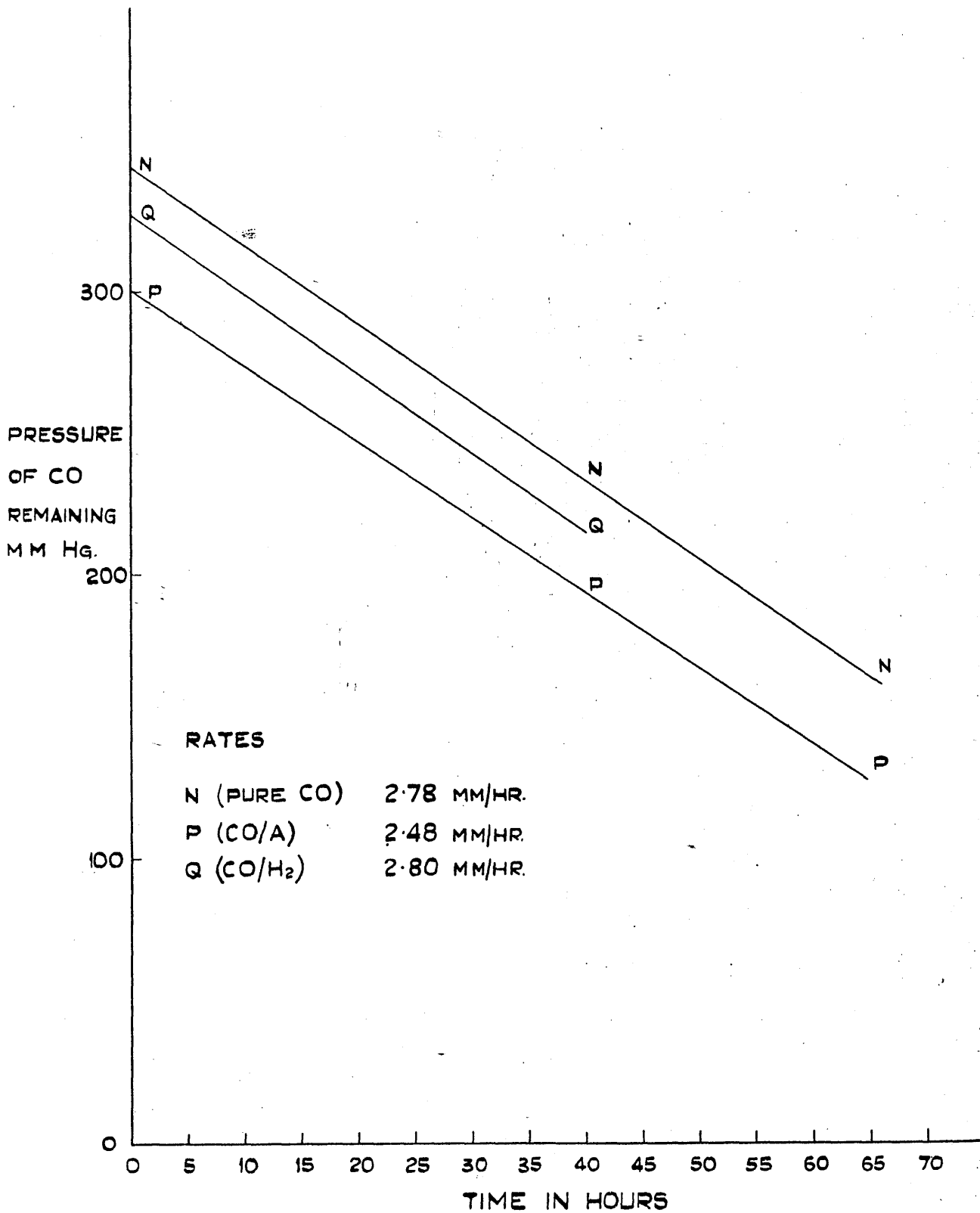

FIGURE 5

first of which, the consumption of pure carbon monoxide passing over the nickel was followed, and then this rate compared with that obtained in the second part where the circulating gas had been changed to a mixture of argon and carbon monoxide. Between the runs the apparatus was completely evacuated and then refilled from the reservoir with a previously prepared homogeneous mixture of carbon monoxide and argon (1:1).

Figure 5 illustrates the results in the normal manner as a plot of the pressure of the carbon monoxide remaining against time, where the pressure of the carbon monoxide was obtained in the second case by subtraction of the pressure of argon (a constant value) from the total pressure of the system. Since the line N for pure monoxide has the same slope as the line P for the mixture it appears that argon exerts no effect on the rate of synthesis of nickel carbonyl under these conditions.

Comparison of the slopes of plots of the pressure against time for pure carbon monoxide and for a mixture of carbon monoxide and hydrogen in a similar experiment showed that hydrogen likewise neither accelerated nor decelerated the reaction at this temperature (cf. figure 5.)

SYNTHESIS AT LOWER PRESSURES OF CARBON MONOXIDE

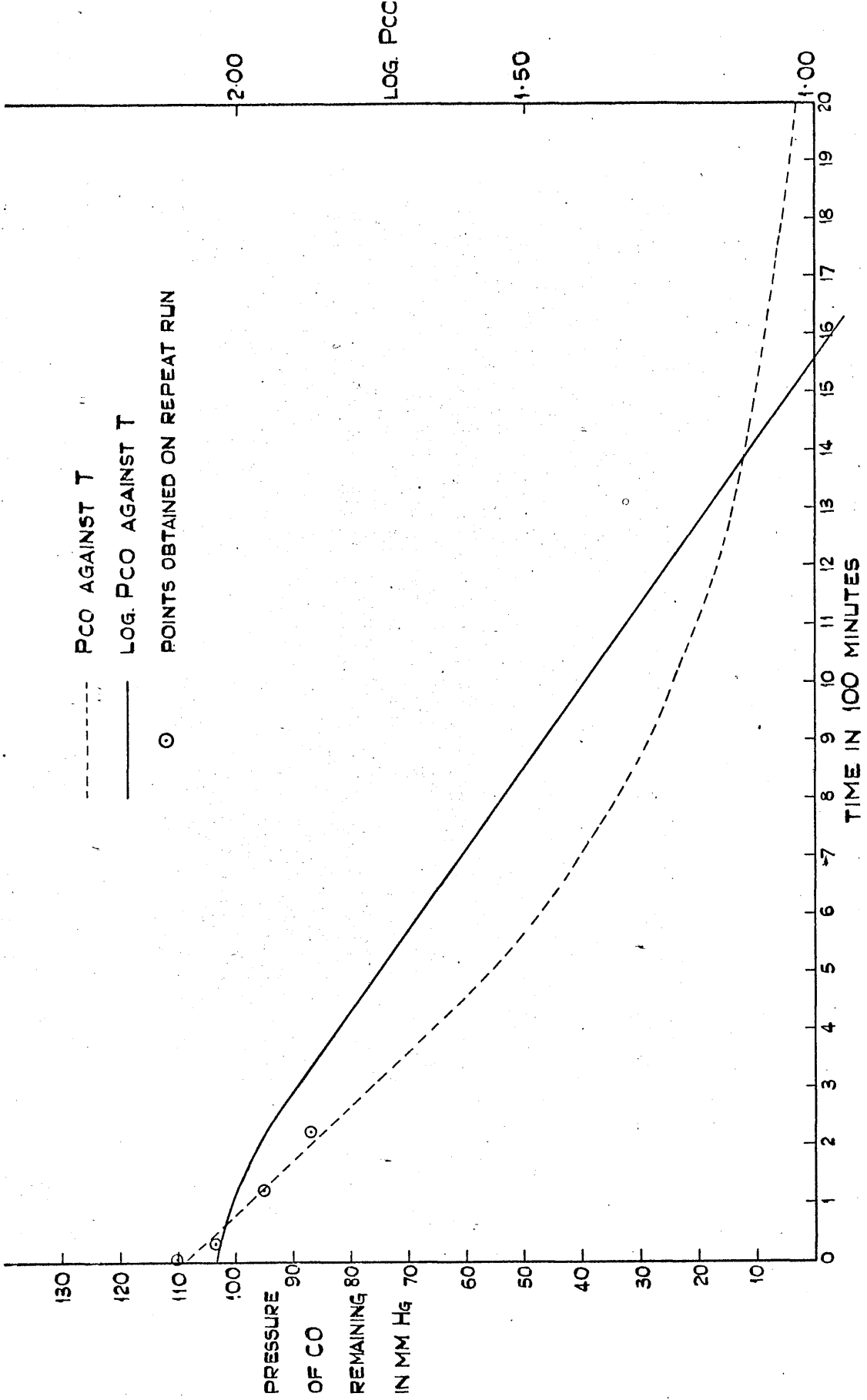

FIGURE 6

c.5. Extension to lower pressures of carbon monoxide.

It is noticeable from the results depicted in figure 4, that when the pressure of carbon monoxide falls below 100mm. of mercury, the plot of pressure against time begins to deviate from linearity. For a closer examination of this effect an experiment was made in which the starting pressure of carbon monoxide was just over 100mm. of mercury (together with an argon pressure of ca. 660mm.) and the rate of consumption of gas was followed in the usual manner.(Figure 6.) From the pressure of 85mm. downwards, the plot was a curve. Inspection of this curve suggested that the reaction was now of first order with respect to carbon monoxide pressure since the time taken to fall from pressure P to $\frac{1}{2}P$ was reasonably constant for all pressures below 90mm., as can also be seen from table II.1. (page 28.) The plot of $\log_{10}P_{CO}$ against time confirmed this conclusion since it is linear. (Figure 6.)

It is worth noting that during this experiment the flow rate was proportional to the total pressure and not to the partial pressure of carbon monoxide, and since the total pressure only fell by 12% over the entire run, then the consequent 12% change in flow rate could hardly be responsible for the noted results although it/

it may have exerted some effect to a much smaller degree.

Table II.1. Half-life values for carbon monoxide.

Pressure (mm.)	$\frac{1}{2}$ Pressure (mm.)	Time taken for change (in minutes)
108	54	523
100	50	485
90	45	460
80	40	440
70	35	440
60	30	440
50	25	440
40	20	435
30	15	415
20	10	390

- - - - -

That these results are not fortuitous can be seen from figure 6 where the individual points marked represent readings taken on a repeat run made after evacuating and refilling the apparatus with the original mixture.

c.6. Summary.

When the nickel surface is of the less active type the foregoing results from this series of experiments have demonstrated that:-

- 1) Provided the pressure of carbon monoxide is sufficiently high the rate of synthesis of nickel carbonyl is not dependent on the amount of carbon monoxide in the circulating gas stream, nor on the rate of flow of this gas.
- 2) The presence of hydrogen and argon neither accelerates nor decelerates the reaction.
- 3) When the pressure of carbon monoxide falls to a point below 100mm. of mercury there is a transition to dependence of reaction rate on the concentration of the carbon monoxide present in the reaction vessel, and the kinetics now take first order form.
- 4) The point at which this change takes place varies from one nickel specimen to the other but the general trend is for more active nickel powders to have a higher value of carbon monoxide pressure at the transition point (cf. lines H,G' and L of figure 4.)
- 5) It has not proved possible as yet to get a standard preparation for the nickel which gives reproducible activity from one specimen to the other.
- 6) The activity of an individual nickel specimen

SCREW DISLOCATION

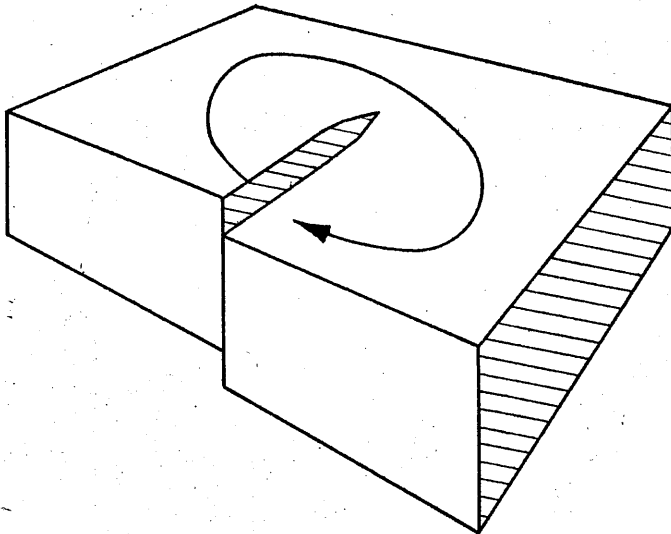
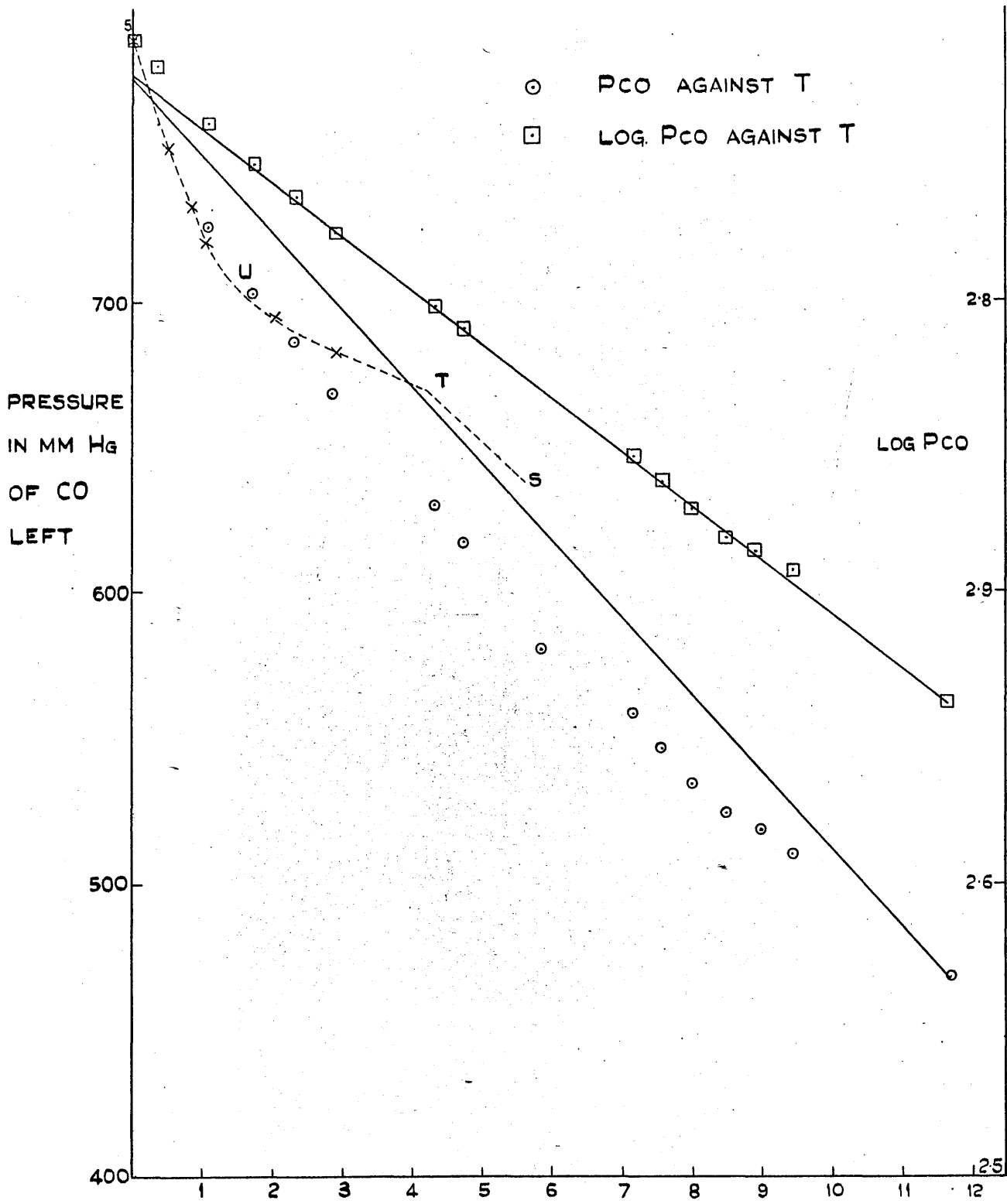

FIGURE 7

remains constant for a surprisingly long time when it is considered that the active sites must be continually being abstracted from the surface. One possible manner in which this could occur is illustrated in figure 7, where the active site is in effect a series of sites joined together - the edge of a screw dislocation- and as a nickel atom is removed from this edge, it leaves exposed behind it nickel atoms or atom , to which it has bequeathed its activity and thus the extraction of several nickel atoms will merely cause the edge to rotate around the axis of dislocation, as shown by the arrow in figure 7, and not reduce the number of active sites to zero. The number of nickel atoms exposed in this way will fluctuate unless the crystal face is perfectly circular - which is extremely unlikely. However the observed activity will be due to a very large number of such faces, and each will show a regular rise and fall in activity so that the statistical average of their activities will remain constant. Therefore , provided there is a sufficient number of faces involved, the observed activity of a nickel specimen could well remain constant.

SYNTHESIS OF NICKEL CARBONYL AT 35°C - FAST REACTION



TIME IN HOURS

FIGURE 8

d) Synthesis of nickel carbonyl at 35°C. - "fast" reaction.

d.1. Pure carbon monoxide.

On circulating carbon monoxide over a more active nickel catalyst, it was found that the plot of the pressure against time was not a straight line as it was for specimens of low activity, but that, as can be seen in figure 8 from a typical result for such an experiment, the reaction was first order with respect to carbon monoxide, for the plot of the logarithm of the pressure of gas remaining was linear.

d.2. Effect of varying flow rate.

The curve S shown as a broken line in figure 8, resulted from an experiment, which, although it failed in its prime object of determining the dependence of reaction rate on carbon monoxide pressure, was of considerable interest since it accidentally showed that the reaction rate was dependent on the flow rate of the gas.

Immediately before making a pressure measurement, it was the invariable practice to fill up the Dewar vessels of the cold traps with liquid oxygen to a standard level, so that there would be no errors caused by variation in temperatures from reading to reading.

In this run the side arm leading into the first cold trap was accidentally cooled with refrigerant during this operation and, as was discovered later, some of the nickel carbonyl product from the reaction vessel was solidified here, producing a constriction which, although it did not completely block the tube, gradually affected the rate of flow by building up a back pressure in the exit ballast bulb of the pump. The reaction rate began to lessen and although at first it was assumed that the nickel was losing its activity, observation of the flowmeter led to an understanding of what had occurred, the constriction was removed by warming the tube, and the run continued for a while to ensure that the nickel was still active. The points at which the constriction developed and was removed are shown in the figure 8 as U and T respectively, and it is apparent that the restriction of the flow rate had also affected the velocity of the synthesis of the nickel carbonyl.

d.3. A new approach.

Since the rate of flow of the carbon monoxide was not maintained constant in the runs of section d.1., but fell gradually as the internal pressure of the system dropped, then in view of the fact that the reaction/

reaction rate is dependent on flow rate, the conclusion based on these runs that the reaction rate is of first order with respect to carbon monoxide concentration, must now be considered invalid. Because of the difficulty of accurately controlling the rate of flow in the apparatus used up till now, it was necessary to modify the procedure before any real quantitative evidence could be obtained as to how the reaction was dependent on pressure and on flow rate.

The most desirable arrangement would be one where the flow rate could be kept constant and the dependence of the reaction rate on pressure be measured and then vice-versa. This requirement was readily met by attaching to the apparatus a gasometer which could be filled with a gas mixture containing carbon monoxide together with any desired proportion of argon, equipped with a "constant head" device to expel this mixture from the gasometer at a steady rate over the flow meter which served as an indicator of the consistency of the flow, and into the reaction chamber. The exit gas could then be led either through a by-pass outlet to the air vent of a Bunsen burner to destroy the poisonous materials, or else down a long Pyrex glass tube heated electrically to between 400 and 500°C., where any nickel carbonyl/

carbonyl would be decomposed leaving behind the nickel as a metal film on the walls of the tube or else as a powder which was filtered from the gas by means of a glass wool plug at the outlet. The exit gas was then collected under water in a graduated flask, and by timing this it was possible to measure the rate of flow.

From the duration of the passage down the tube and from the weight of nickel deposited (estimated as described in the experimental section) it was a simple matter to calculate the rate of synthesis of nickel carbonyl. By using the same gas mixture each time but varying the flow rate from run to run, it was possible to determine the manner in which the rate of reaction depended on the flow rate, and similarly, by using a constant flow rate and varying the composition of the gas, the dependence on pressure of carbon monoxide in the reaction vessel could be found.

d.4. Constant pressure - varying flow rate.

After filling the gasometer with pure carbon monoxide, this gas was caused to flow through the by-pass at a constant rate for over ten minutes, allowing the system to reach dynamic equilibrium. The direction of the/

DEPENDENCE OF REACTION RATE ON FLOW RATE

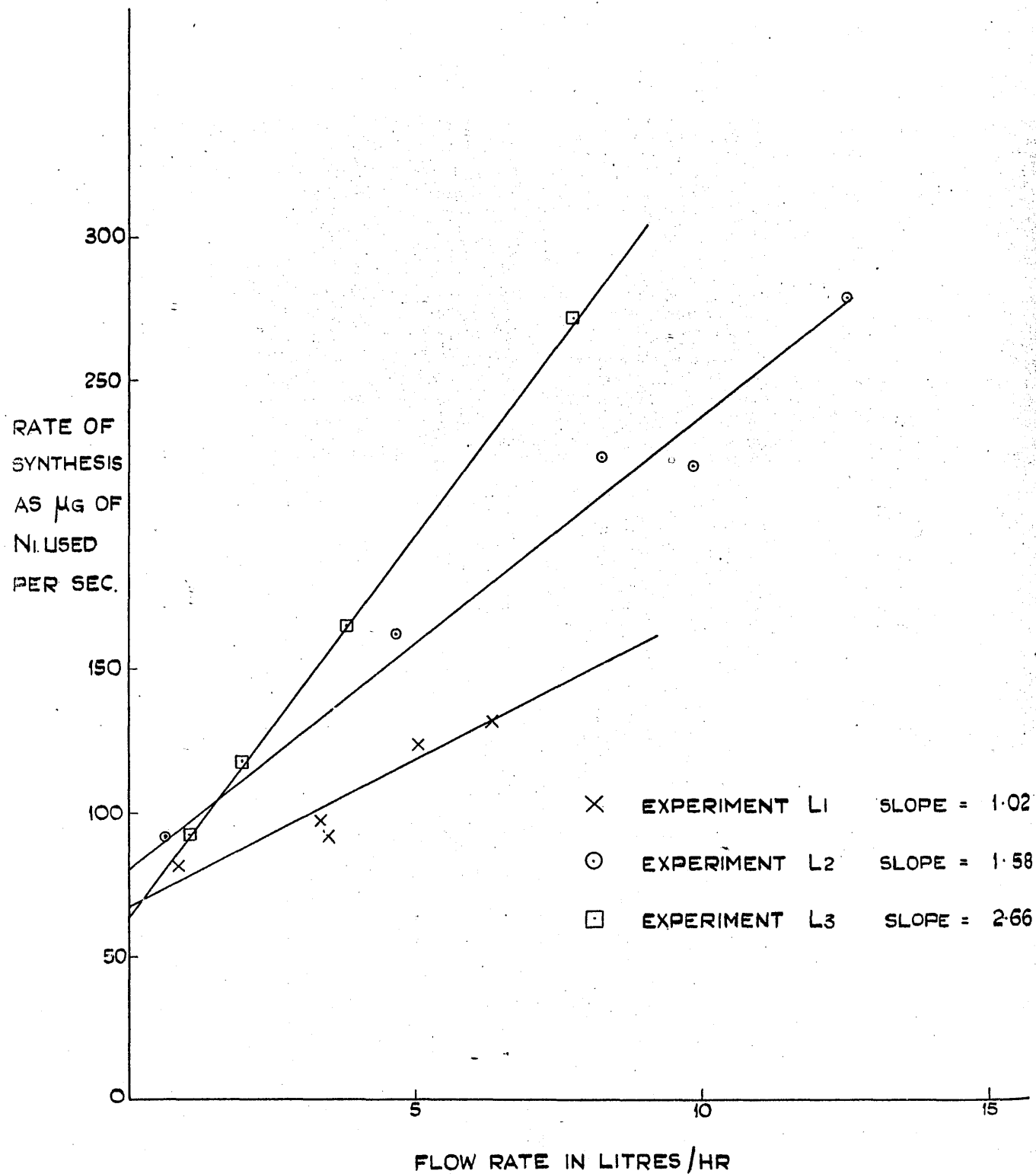

FIGURE 9

the exit gas from the reaction chamber was then changed, by means of a three way tap, to the hot tube line and the gas allowed to flow for a noted length of time before being returned to the by-pass outlet. The hot tube was then removed, cooled, and the nickel deposit was dissolved in nitric acid and the solution retained for analysis. The tube was replaced and the procedure repeated at a different flow rate.

To minimise the error imposed during the first few seconds of the decomposition as the system built up to a steady state, the runs were made of a duration of at least half an hour. During the run the pressure within the reaction chamber was read from a manometer and it was found to vary slightly from run to run but to a negligible extent as can be seen from the table II.2. overleaf, which contains a summary of the results.

These results are also illustrated graphically in figure 9, where it can be seen that the rate of reaction is directly proportional to the rate of flow of the carbon monoxide, since the plot of the one rate against the other is a straight line. However the outstanding feature of this graph is that not one of the lines resulting from this (L_2) and other similar experiments, (L_1 and L_3 , using different nickel specimens), passes through/

through the origin but each makes an intercept on the rate of synthesis axis. While it is obvious that without flow no nickel could possibly be transferred as carbonyl from the reaction tube to the decomposition tube, so that the extrapolation is theoretically unjustified, yet, if the quantity Ni/sec. is viewed not as the amount of nickel deposited per second in the hot tube but as the amount of nickel removed per second from the metal surface in the reaction chamber, then it is probable that the intercept has a significance viz. - that it represents the rate of synthesis that would occur in the reaction vessel where there is no flow and where the pressure of carbon monoxide is 770mm. of mercury.

Table II.2. Results of experiment L₂.

Weight of nickel (mg.)	243	342	483	448	553
Time of run (secs.)	2700	2100	2160	2040	1980
Rate of synthesis (Ni used/sec.)	90	173	223	220	279
Flowmeter reading (Mm.)	8.5	63	112	133	170
Calculated flow rate (ml./sec.)	0.18	1.30	2.30	2.74	--
Observed flow rate (ml./sec.)	0.19	1.44	2.30	2.78	3.50
Pressure in reactor (mm. of Hg)	771	773	779	782	785
Run number	1	2	3	4	5

Results for series M runs - total flow rate constant.

P_{CO} (mm.)	Nickel deposit (mg.)	Total flow rate (l/hr.)
39	12.1	14.7
110	14.1	14.8
206	17.1	14.6
413	33.5	14.5
795	48.2	14.6

d.5. Constant flow rate - varying carbon monoxide pressure.

The reciprocal experiment was then made, in which the rate of flow of gas was kept constant during runs with various pressures of carbon monoxide and argon diluent.

A gas mixture of argon and carbon monoxide in known proportions made in the gasometer was expelled (by displacement with water) through the reactor and into the Bunsen at a known constant rate, until a steady state could be assumed within the system (15 minutes). The gas was then altered in direction into the heated tube for a known length of time, and by estimation of the resultant nickel deposit, it was possible to determine the rate of synthesis of nickel carbonyl under these conditions.

The run was repeated several times with a different ratio of carbon monoxide to argon in each case, but with the total rate of flow maintained constant throughout, as can be seen from the table opposite summarising the results for this series, where the experimentally determined rate of flow for each run is noted. These results are depicted in figure 10 , where it can be seen/

DEPENDANCE ON PRESSURE OF CARBON MONOXIDE

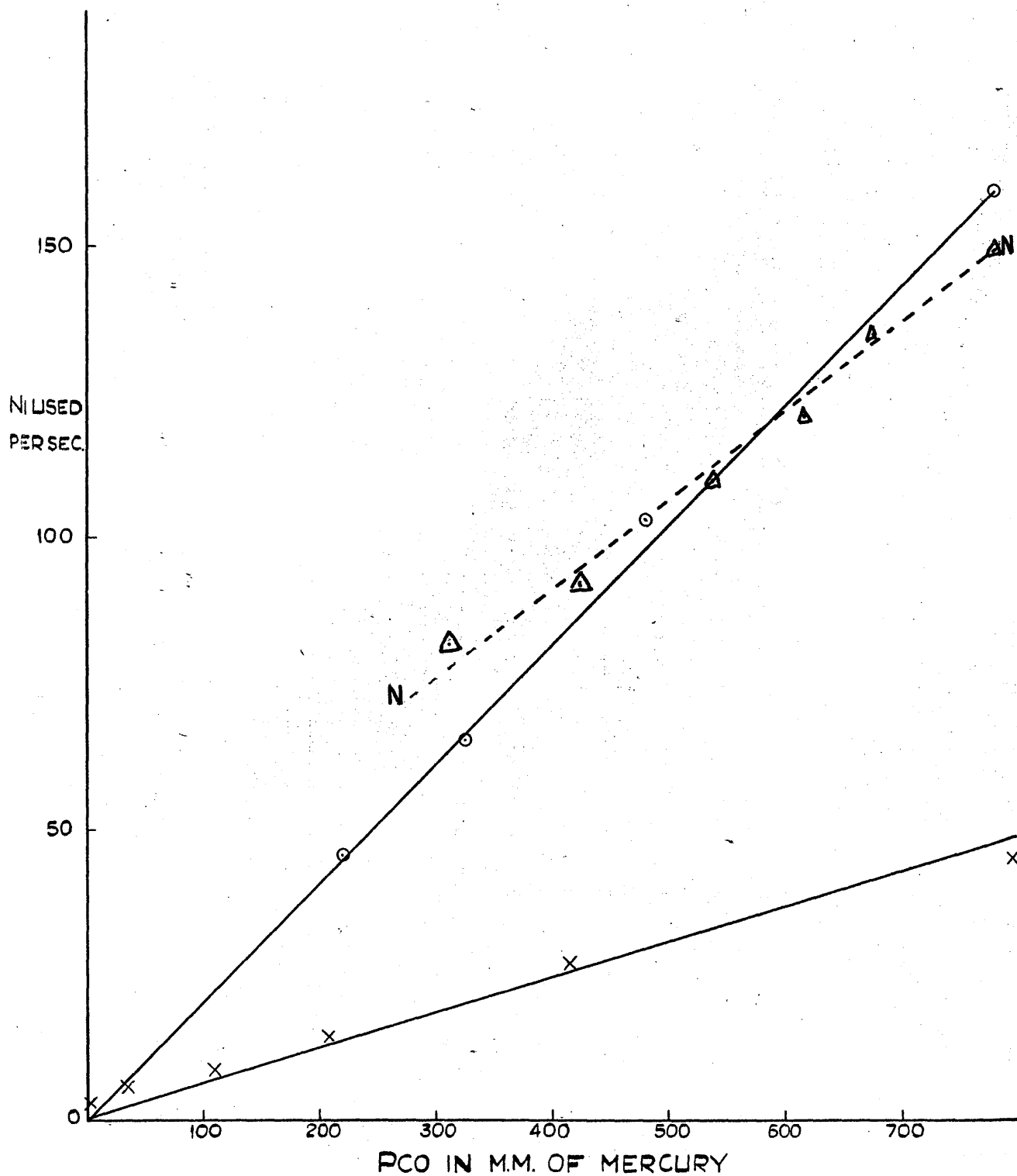

FIGURE 10

seen that the rate of reaction is directly proportional to the first power of the carbon monoxide concentration except where this becomes very low, for the points near the origin show a marked deviation from the line, having values for the rate of synthesis which are over 100% greater than the expected value. Such a deviation is outwith the experimental error and can not be caused by the slightly higher flow rate associated with this run. (The points for this experiment are marked by crosses in the figure 10.)

The best straight line through these points makes an intercept on the rate of synthesis axis, suggesting that no carbon monoxide is necessary to synthesise the carbonyl. A run was therefore made using pure argon to see whether the line made an intercept on the axis or not, and it was found that even although no carbon monoxide was supplied to the nickel, a substantial amount of nickel was transferred to the hot tube. At the end of this run argon was allowed to flow from the cylinder over the nickel and out through the by-pass into the Bunsen where it imparted to the flame the yellow-grey coloration characteristic of nickel carbonyl. This colour persisted after two hours of argon flow, showing that carbonyl was still present in the exit gas/

gas suggesting that either desorption of carbonyl from the metal surface is a slow process or that the synthesis was being continued by carbon monoxide still adsorbed on the surface.

The results of the foregoing experiment are paradoxical in that they show that the reaction rate is proportional to the carbon monoxide concentration provided the total rate of flow is maintained constant, and yet it would be expected that the reaction rate would be dependent on the carbon monoxide concentration only if the flow rate of carbon monoxide were maintained constant. Keeping the monoxide flow rate constant from run to run is a difficult task if the percentage of monoxide in the gas is varied. A relationship exists between the flow rate of carbon monoxide (f_{co}) and the flow rate of total gas (f_t), pressure of carbon monoxide (P_{co}) and total pressure (P_t) in the gasometer such that

$$f_{co} = \frac{P_{co} f_t}{P_t} .$$

Hence, since the fraction of gas which is carbon monoxide is known, the total rate required to give a desired flow rate of carbon monoxide can readily be calculated. However, it was not found so easy to adjust the total flow rate with great precision but, since a/

a cylinder of carbon monoxide fortunately became available, it was possible to use a different technique.

Using this cylinder and a needle valve attachment, it was possible to maintain an absolutely constant rate of flow of carbon monoxide. This gas could be diluted with argon from another cylinder by letting both flow into a mixing chamber and then leading the mixture over the nickel in the normal manner. By experimental determination of the total rate of flow, and measurement of the total pressure of gas in the reaction vessel, it was possible to calculate the pressure of carbon monoxide above the nickel since f_{CO} is a constant, and

$$f_{CO} = \frac{P_{CO}}{P_t} f_t \quad \text{therefore} \quad P_{CO} = \frac{f_{CO} P_t}{f_t}$$

Using this technique and varying the amount of argon flow from run to run, it was possible to determine the dependence of the rate of reaction upon the carbon monoxide pressure when the flow rate of carbon monoxide is constant. Results for this series of runs (N) are shown as a broken line in figure 10, page 38, where the relationship is again first order with respect to carbon monoxide concentration, but the line did not pass through the origin.

d.6. Dependence on pressure of nickel carbonyl.

The rate of synthesis of nickel carbonyl was determined for the passage of pure carbon monoxide over nickel at 35°C . at a rate of 5.20 litres per hour, in terms of mg. of nickel deposited per second on the decomposition tube. The run was then repeated under identical conditions except that the gas was bubbled through nickel carbonyl liquid, then through two cooled traps (-24°C .) where it was saturated with a known amount of vapour and then into the reaction vessel. This technique of imparting a constant partial pressure of nickel carbonyl to a gas stream is described fully in the experimental section. The rate of deposit of nickel in the hot tube was found in this case to be equal to that of the previous run plus the amount of nickel picked up by the gas stream as carbonyl vapour, i.e. the rate of synthesis of nickel carbonyl is apparently independent of the partial pressure of nickel carbonyl vapour present in the reaction vessel. The results are summarised overleaf showing that an increase of over 200% in the carbonyl vapour concentration in the reaction vessel had no apparent effect on the rate of synthesis.

Table II.3.

	Ni deposited (g./sec.)	Ni picked up (g./sec.)	Ni from synthesis (g./sec.)
Pure CO	123	0	123
CO + Ni(CO) ₄	409	290	119
)- - - - - (

II.e. Summary.

The foregoing work has shown -

- 1) Decomposition of nickel formate gives rise to either an active or a less active form of nickel.
- 2) The less active form reacts with carbon monoxide to form nickel carbonyl at a rate which is independent of carbon monoxide concentration, nickel concentration, and flow rate of gas provided they do not fall to a very low value.
- 3) The rate of reaction between the more active nickel and carbon monoxide is dependent on the first power of the carbon monoxide concentration if the flow rate of carbon monoxide or the total flow rate is kept constant, or if the flow rate of carbon monoxide is directly proportional to the carbon monoxide pressure. Moreover the rate of synthesis is independent of the amount of/

of nickel or of nickel carbonyl vapour present in the reaction zone.

4) Nickel carbonyl continues to be produced when the supply of carbon monoxide to the catalyst is discontinued.

II.2.f. Discussion of the results.

f.1. "Slow" synthesis.

This reaction is apparently of zero order since its rate is independent of the pressure of carbon monoxide and of the flow rate in the system. (cf. fig.3.)

Application of the normal explanation of zero order kinetics is quite satisfactory here, if it is assumed that the reaction takes part in three stages.

- 1) Adsorption of carbon monoxide on the nickel to form some complex.
- 2) Reaction of this complex to give nickel carbonyl.
- 3) Desorption of nickel carbonyl.

Because the rate of (1) is dependent on the pressure of carbon monoxide in the gas phase and this varies throughout the run, then stage (1) can not be the slowest step in the reaction. In a similar manner since step (3) is dependent on the pressure of nickel carbonyl in the gas phase, and this in turn is dependent on the/

the rate of flow of gas through the system, since the higher the flow rate the lower will be the partial pressure of carbonyl above the nickel, then stage (3) can not be the slowest stage of the synthesis, since the latter is independent of flow rate. By elimination, step (2) must therefore be the rate determining stage of the reaction, but the experimental data shed no light on the actual mechanics of this stage.

For zero order reactions it is normal to assume that the active surface is saturated or nearly saturated with reactant, so that considerable amounts of reactant can be removed by chemical change without affecting the amount in the adsorbed layer since that which reacts and leaves the surface is immediately replaced from the gas phase. When the pressure of reactant is sufficiently reduced, however, a point must come when the surface is no longer saturated, and the zero order reaction passes into one of the unimolecular type. Although the reaction under consideration here differs from the usual zero order reaction in that the nickel surface participates actually to the extent of being removed by the reaction, there seems little reason to doubt that it is normal in so far as there is a very high extent of coverage of the surface by carbon monoxide. The relative/

relative slowness of the reaction can be taken to be caused by the fact that only a small number of active sites exist. The results obtained at lower carbon monoxide pressures agree with the normal case, since the reaction becomes dependent on the carbon monoxide pressure, suggesting a transition to a state in which there exists a number of unoccupied sites on the nickel and the overall reaction rate is now dependent on the rate at which carbon monoxide is adsorbed on these sites.

It is probable from consideration of this change from zero into first order kinetics, that classification of the nickel specimens into "fast" and "slow" types is one of degree rather than of kind and that the only difference between the two is that the "fast" nickel has many more active sites per unit weight than has the "slow" type. If it had been possible to raise the pressure of carbon monoxide in the cycling unit to well above atmospheric, then it is probable that all the "faster" nickel specimens would show a change in kinetics from first to zero order at some higher pressure of carbon monoxide, different of course for each individual sample.

Key to symbols used in the discussion opposite.

- r = rate of reaction
 P_1 = pressure of carbon monoxide
 P_3 = total pressure
 f_1 = flow rate of carbon monoxide
 f_3 = total flow rate
 n_1 = number of carbon monoxide molecules
 n_3 = total number of molecules
 t = time

The symbols k , k_1 , k_2 , k_3 , etc., represent different constants.

f.2. "Fast" synthesis.

The experiments outlined have shown that this reaction is dependent on the pressure of carbon monoxide and also on its flow rate. The results suggest a relationship of the type

$$\text{rate of reaction} = kP_1 + k_1f_1 \quad \dots\dots(1)$$

where k and k_1 are constants, P_1 and f_1 are respectively the pressure and flow rate of carbon monoxide.

(A key to all the symbols used in this discussion is given on the opposite page.)

f.3. Applications of this expression.

a) Cycling experiments.

In these runs an empirical relationship was found

$$-dP_1/dt = k_2P_1 \quad \dots\dots(2)$$

where no allowance was made for the varying rate of flow.

Since the volume of the stroke of the pump was constant, from the relationship $PV=nRT$ where V , R , and T are constant, the total number of gram-molecules n of gas transferred per stroke of the pump is dependent directly on the total pressure. Therefore

$$f_s = k_3P_s \quad \dots\dots(3)$$

Also when a mixture of gases is cycling

$$f_1 = \frac{P_1}{P_3} f_3$$

and equation (1) can be modified to

$$\begin{aligned} r &= kP_1 + k_1 \frac{P_1}{P_3} f_3 \\ &= P_1 \left(k + \frac{k_1 f_3}{P_3} \right) \end{aligned}$$

and from equation (3)

$$\begin{aligned} &= P_1 (k + k_1 k_3) \\ &= P_1 k_4 \end{aligned}$$

Since in the cycling experiments the rate of reaction is given by $-dP/dt$, it is apparent that the equations (1) and (2) are equivalent.

b) Variation of flow rate of carbon monoxide at constant pressure (f_1 varied, P_1 constant.)

Equation (1) was suggested by the results of these experiments when plotted as in figure 9, page 35, the linear relationship

$$y = mx + c$$

becoming $r = k_1 f_1 + c$

Since P_1 is constant here, c can be replaced by kP_1 and equation (1) results

$$r = k_1 f_1 + kP_1$$

c) Variation of carbon monoxide pressure with constant flow rate (i.e. f_1 constant, P_1 varied.).

This is analogous to the previous case (b) since from the linear relationship shown in figure 10, page 38,

$$y = mx + c \quad \text{(broken line)}$$

becomes $r = kP_1 + c$

and again , since f_1 is constant, c can be replaced by $k_1 f_1$ and equation (1) results.

d) Variation of carbon monoxide pressure with total flow rate constant (f_s constant, P_1 varied.).

These results are shown in figure 10, page 38, where the line (marked by crosses)

$$r = k_5 P + c \quad \text{.....(5)}$$

passes almost through the origin.

Since f_s is constant and P_s is constant,

$$f_1 = k_6 P_1$$

and therefore equation (1) becomes

$$\begin{aligned} r &= kP_1 + k_1 k_6 P_1 \\ &= k_7 P_1 \end{aligned}$$

This is identical with (5) if the constant c is zero. Since figure 10, (lower line) suggests that c has a small positive value, a modification of (1) is suggested.

$$r = kP_1 + k_1f_1 + k_8f_3 \dots\dots\dots(6)$$

but application of this equation to case (a) and to case (c) showed that it only held provided k_8 was extremely small, so that k_8f_3 only became significant when P_1 was very small.

Assuming that

$$r = kP_1 + k_1f_1$$

holds, then application to the experimental data shows that constants k and k_1 have different values for different nickel specimens, otherwise all the results should give rise to only one straight line on figure 9 and not several as shown.

f.4. Explanation.

The physical explanation of this equation is not obvious. A normal first order reaction in a flow system is dependent on pressure and flow rate of reactant but in an entirely different manner, the two factors being interrelated in such a way that an expression of the type (1) is not possible.³¹ However, the fact that nickel carbonyl synthesis does not conform to rule, is not surprising for it is not a true flow reaction in the generally applied sense of the term since only/

only one of the reactants is flowing the other being stationary.

Qualitatively the synthesis would be expected to be dependent on P_1 and f_1 since it is a gas/solid interaction and the rate of reaction could be expected to be dependent on the number of collisions between the reactants i.e. on the pressure P_1 of the gas in the reaction vessel, and without flow the value of P_1 would fall rapidly. The puzzling feature is not the existence of the relationship (1) but the remarkably high value of the constant k_1 (cf. figure 9), where the reaction rate is increased by a factor of some 35% when the flow rate is increased by a factor of 100%. If the function of flow were merely to replace the carbon monoxide molecules used up, such a rapid increase of reaction rate with rise in flow rate suggests that most of the carbon monoxide molecules in the reaction vessel are being consumed as fast as they can be replaced. Since at a flow rate of 1 litre per hour only 11% of the carbon monoxide passing through is consumed, it is apparent that the flow has some other function apart from replacing the lost carbon monoxide.

One possible such function is that the rate of synthesis is dependent on the rate of removal of nickel/

nickel carbonyl from the system. Increase in the flow rate would decrease the partial pressure of nickel carbonyl in the system and speed up the rate of desorption of the carbonyl. However there is a good reason why this can not be valid here, since the passing of nickel carbonyl vapour over the catalyst together with the carbon monoxide showed that increase of the partial pressure of the carbonyl in the reaction vessel had little repressive effect on the reaction, since the synthesis rate fell by only 4% for a rise of 350% in the nickel carbonyl vapour pressure. (cf. page 41.)

A tentative explanation of the significance of equation (1) can however be made as follows:-

Considering the case where there is no enforced flow of gas, the number of collisions between carbon monoxide and the nickel will become rapidly dependent on the rate of diffusion of carbon monoxide towards the metal powder bed from outside it. After a few seconds of reaction a concentration gradient will be set up at the ends of the bed in which the amount of nickel carbonyl at the bed will greatly exceed the amount in the gas at some distance from the metal, and this situation will be reversed for carbon monoxide concentrations. Hence the overall rate of reaction will become dependent/

dependent on the diffusion coefficients of the two gas molecules concerned i.e. on the rate at which nickel carbonyl can diffuse through and away from the metal bed, or on the rate at which carbon monoxide can diffuse into the metal bed. These rates of diffusion are not known but it would appear safe to assume that for both gases the average displacement of a molecule is less than 1 cm./sec. (For instance, in a table of diffusion coefficients given in Farkas and Melville's " Experimental Methods in Gas Reactions", (page 16), only one of the rates of diffusion in over thirty quoted examples exceeds 1 cm./sec., and that is diffusion of hydrogen in hydrogen.) The temperature in the present case (35°C.) is only slightly higher than for these examples (0°C.), and therefore the rates of diffusion are not likely to be much higher at 35°C., and 1 cm./sec. appears to be a reasonable upper limit.

If now flow is applied to the system, the natural result will be to increase

- a) The rate at which carbonyl is removed from the bed.
- b) The rate at which carbon monoxide molecules come in contact with the metal bed.

Consideration of the dimensions of the reaction/

reaction chamber shows that a flow rate of 4 litres per hour is equivalent to an average displacement per molecule of gas of 1 cm. per second into the reaction zone, followed by a very much higher rate of flow through the bed (fairly closely packed so that the volume of space through which flow is possible is small compared with the overall volume of the reaction tube) and then reverting to 1 cm. per second at the outlet end of the vessel.

This means that nickel carbonyl produced within the bed will be removed extremely rapidly by comparison with the speed at which it was removed when there was no flow, and therefore the overall rate of reaction will now be dependent on the rate at which carbon monoxide molecules collide with active sites on the surface of the nickel.

The chances of any particular carbon monoxide molecule hitting an active nickel site and being retained there will be governed by two factors.

- 1) The probability of it making a collision whilst within the nickel bed.
- 2) The chances of it hitting a nickel atom at the inlet end of the bed before entering the bed.

Since the cross-sectional area of the metal exposed to the flow remains constant then factor (2) will remain constant per molecule. Factor (1) will be dependent mainly on the time for which the molecule is within the catalyst bed and this will be dependent in turn on the total flow rate f_g through the bed, and if a gas mixture is involved (1) will be proportional to f_g i.e. to

$$\frac{P_a}{P_1} f_1.$$

If carbon monoxide at f_1 ml. at N.T.P. per second is led into the reaction vessel in a stream of gas mixture flowing at a total of f_g ml. per second, then the average number of carbon monoxide molecules entering the bed is n per second where

$$n = f_1/22,400$$

and the average time each of these molecules spends within the metal bed is V/f_g , where V is the volume of the gas space within the bed.

Let A be the cross-sectional area of the metal exposed to the gas at the inlet end of the bed, and let k_g be the constant fraction of molecules entering the bed which make a successful collision with the end of the bed. Further let k_{10} be the constant of proportionality between the time a molecule spends in the metal bed and its chances of making a successful collision.

The rate of reaction is therefore given by the sum of reaction within the bed and reaction at the end of the bed if it is assumed that the fraction of the entering molecules lost at the end of the bed is small.

$$\begin{aligned}
 r &= k_9 n_1 + n_1 k_{10} V / f_3 && \dots\dots\dots(7) \\
 &= \frac{k_9 f_1}{22,400} + n_1 k_{10} \frac{V P_1}{P_3 f_1} \\
 &= k_{11} f_1 + k_{10} \frac{22,400 V P_1}{P_3}
 \end{aligned}$$

If V and P₃ are constants this expression can be written

$$r = k_1 f_1 + k P_1$$

This is expression (1).

In the cycling experiments there is a further relationship between f₁ and P₁, (f₁ = k₃P₁), and the equation now reduces to

$$r = P_1 k_2$$

so that the rate of fall of pressure in the apparatus at time t is proportional to the pressure of carbon monoxide at time t.

The ratio of k₁ to k will depend on the disposition of the metal and will vary from specimen to specimen. The high ratio observed in the three experiments of/

of figure 9 suggests that the amount of reaction from end collisions is a high proportion of the whole and therefore that the gas is passing through the metal bed via channels, so that not all the active sites on the nickel are exerting their utmost effect, that is to say that the flow effect of sweeping out the nickel carbonyl formed is localised to several main streams, and there are many side passages (pores etc.) in the metal bulk in which contact between carbon monoxide and nickel is dependent on diffusion. The experiment in which nickel carbonyl was produced by passing pure argon over a previously used nickel specimen gives evidence for this conclusion, since this carbonyl could have been produced by slow diffusion from these side passages.

Unless the passages are pores in the individual nickel grains, then this effect could probably be overcome by making the powder bed more "fluid", so that even the low rates of flow which are possible at the pressures obtainable within the apparatus could prevent such channelling by stirring and sifting the metal particles.

II.2.g. Anomalous data.

It is worth noting that in a few cases, observed data for the cycling experiments did not fit in with the general run of results, An example is given by line F on figure 4 page 24, where the plot of P_{CO} against time was a curve suggesting the "fast" type of run, but the plot of $\log P_{CO}$ was not linear as is normal with such runs. This also occurred in another "fast" experiment but in neither case were the results reproducible, and in actual fact the repeat of the second case gave rise to a normal "fast" run.

II.2.h. Conclusion.

Whilst quite consistent in itself, the foregoing work is of little value in determining the mechanism of the synthesis of nickel carbonyl from carbon monoxide and nickel, since it indicates merely that the rate determining step of the reaction is collision between nickel and carbon monoxide to form a surface complex probably of the form $Ni(CO)$.

However it has shown that Mittasch was probably mistaken in his conclusion that the synthesis was in two stages with formation of $Ni(CO)_2$ as the first step.

It seems likely that his results were fortuitous since he took no steps to remove the nickel carbonyl formed from the system, and moreover even carried out some of his observations with the system under conditions where volatilisation of the product was not high, e.g. at 0°C. where the vapour pressure of nickel carbonyl is only 144mm. of mercury. Therefore the nickel carbonyl produced would block further reaction until it diffused away from the nickel, and it seems probable that in such a system the rate determining step of the reaction would be removal of product from the surface making the reaction dependent on the diffusion coefficient of nickel carbonyl under these conditions.

II.3. The thermal decomposition of nickel carbonyl.

a) Introduction.

The spontaneous decomposition of nickel carbonyl at various temperatures has been studied by Garratt and Thomson,^{3,2} by Bawn,²⁵ and also by Tonosaki and Suginuma.²⁶ Their results all concur in showing that the kinetics of decomposition in a static system are given by/

by

$$\frac{dx}{dc} = \frac{k [\text{Ni}(\text{CO})_4]}{1-k_1 [\text{CO}]}$$

an equation which was

interpreted as showing that the decomposition took place in more than one step, and that the first step is



Nevertheless, since in the present work the system under study is a flow system, it was considered worth while investigating this reaction afresh by a flow technique before any attempt was made to apply the results to an interpretation of the Fischer-Tropsch synthesis mechanism.

b) General procedure.

A gas carrying a known constant proportion of nickel carbonyl vapour was passed through a reaction vessel maintained at the desired temperature, where some of the carbonyl decomposed. The effluent gas was then passed through a long strongly heated tube where the remaining carbonyl was decomposed. From the rate of deposit of nickel in these two places, and from the flow rate of gas and the volume of the reaction vessel it was possible to determine the percentage decomposition of the nickel carbonyl in passing through the reaction vessel. By varying the flow rate of carrier gas from/

from run to run, it should have been possible to determine the kinetics of decomposition of carbonyl, and by varying the amount of carbon monoxide in the carrier gas, the retardation of the decomposition by carbon monoxide could be followed.

c. Results.

The results were very disappointing for, although a considerable amount of time was spent on this work (over two hundred runs were made), the reproducibility of the results was remarkably poor. Although the reaction vessel was cleaned with meticulous care between the runs and precautions were taken to maintain all possible variable factors constant, the deposit of nickel in the reaction vessel was often visibly uneven, bare patches of glass showing amongst the nickel coating. The reason for this is not known but is probably related to the known heterogeneity of the reaction, so that the reaction is highly susceptible to the effects of very small traces of impurity, or to variations in the direction of flow into the reaction vessel.

The work was not however completely without reward since several qualitative results were obtained, and further, a method of maintaining a fixed percentage of /

of nickel carbonyl vapour in a gas stream was found and this was made use of later.

d) Qualitative results.

1) Nickel carbonyl at pressures of up to 144mm. of mercury, could be carried in a stream of dry nitrogen through a tube at 35°C. without any decomposition occurring, although traces of oxygen were sufficient to start decomposition even at this temperature.

2) In the absence of nickel catalyst in the system, apparently none of the nickel carbonyl (6% by volume) survived the treatment of being carried by a stream of pure carbon monoxide at 5 litres per hour through the reaction vessel used for carbonyl and Fischer-Tropsch synthesis at 190°C.

However passage of this same mixture, through the same vessel at 190°C. but with a nickel catalyst present, and then through the hot tube gave rise to a definite nickel deposit, suggesting that either some of the original carbonyl was getting through or else that nickel carbonyl can be synthesised under these conditions.

II.4. Correlation of the synthesis of nickel carbonyl with the Fischer-Tropsch synthesis.

a. Synthesis of nickel carbonyl from a nickel Fischer-Tropsch catalyst at 35°C.

A nickel catalyst for use in the Fischer-Tropsch synthesis was prepared as described in the experimental section. Passage of carbon monoxide over this catalyst at 35°C. and through the heated decomposition tube showed that the catalyst was active in the synthesis of nickel carbonyl.

Cycling carbon monoxide in the closed system over this catalyst at 35°C., showed that the synthesis of nickel carbonyl gave zero order kinetic results and that the catalyst could be classified as of the "slow" type.

b. The synthesis of nickel carbonyl under Fischer-Tropsch conditions.

As previously mentioned, according to the equilibrium data of Mittasch, when carbon monoxide at $\frac{1}{2}$ atmospheric pressure is passed at 190°C. over nickel, the amount of nickel carbonyl present in the effluent gas should be negligible. However it was found that on passing a stream of argon and carbon monoxide in equal/

equal proportions at 5 litres per hour over the nickel Fischer-Tropsch catalyst at atmospheric pressure and at 190°C., that a considerable amount of nickel was deposited on leading the exit gas down a heated decomposition tube for two hours.

The same catalyst was flushed with hydrogen for twelve hours and then a similar run was made but this time substituting hydrogen for the argon. After passing this gas for the same length of time, there was no deposit in the hot tube.

Another passage of argon and carbon monoxide gave a nickel mirror as before, showing that there had been no change in the ability of the catalyst to produce nickel carbonyl, and therefore during a Fischer-Tropsch reaction, since there is no carbonyl present in the effluent gas, either it has been formed and then decomposed or else its formation has been suppressed.

To complete this evidence, the cycling unit was filled with the hydrogen/carbon monoxide mixture (1:1) to atmospheric pressure, and this gas was circulated over the nickel at 190°C. for two hours, over which time there was a loss of pressure of 48mm., which is equivalent to a contraction of 5% in the passing gas.

This showed that the catalyst was active in the Fischer-Tropsch reaction, the contraction being comparable with values reported by other workers with this type of catalyst. ⁴⁸

c. The rate of synthesis of nickel carbonyl at 190°C.

Since there is considerable decomposition of nickel carbonyl at 190°C., any determination of the rate of synthesis of carbonyl at this temperature will give the apparent rate and not the true rate. An attempt was therefore made to extrapolate an Arrhenius plot from rates determined at much lower temperatures and to calculate the absolute rate of synthesis at 190°C.

The rate of synthesis of carbonyl from a nickel Fischer-Tropsch catalyst was determined at various temperatures using the cycling technique with a gas mixture of hydrogen and carbon monoxide in the ratio 1:1, flowing at 5 litres per hour.

For each individual determination, the cycle was evacuated to a hard vacuum, then filled to 760mm. pressure with the gas mixture, which was then circulated, and the time taken for the pressure to fall to 740mm. was determined. Since the catalyst was a "slow" one, the kinetic formula $-dP/dt = k$ was valid, and hence the rate constant k was readily calculated for each case.

Summary of the results Table II.4.

Temperature °C.	°A.	Time for fall in pressure (hours)	k mm./hr.	Log k	$\frac{1}{T} \times 10^5$
28	301	5.23	3.82	0.582	332
35	308	4.25	4.68	0.670	325
49	322	3.33	5.99	0.774	311
57	330	2.30	6.81	0.833	303
65	338	2.28	6.95	0.842	296
35 ₁	308	4.37	4.57	0.660	325
80	353	3.32	6.02	0.786	283
35 ₂	308	4.91	4.06	0.609	325
100	373	6.02	3.32	0.521	268



As can be seen from the above figures, the plot of log k against $\frac{1}{T} \times 10^5$ was non-linear even for the three lower values of T. This deviation from linearity is probably caused by decomposition of nickel carbonyl taking place simultaneously with the synthesis. Extrapolation to 190°C. of the best straight line through the points for the four lowest values of T gave an approximate value at this temperature for k of 70mm./hr.

A run at 35°C. was made between the run at 65°C. and the run at 80°C., and was found to give almost the same/

same value for k as in the previous run at 35°C . (4.57 and 4.68 respectively). However a similar repeat between the 80°C . and the 100°C . run gave a value for k of 4.06 which was much lower than the previous case. The interpretation of this observation is that the catalyst has changed in some way by this treatment at 80°C . losing part of its activity, and therefore the calculated value for k at 190°C . is of doubtful validity. Nevertheless it is substantially greater than necessary to account for the loss in pressure during the Fischer-Tropsch synthesis previously described, (24mm. per hour, i.e. 8mm. of carbon monoxide per hour.)

An estimate of the extent to which the catalyst lost its activity by heating it to 190°C ., was made by determining k at 35°C ., raising the temperature to 190°C . and cycling the gas mixture for 15 minutes, then redetermining the value of k at 35°C . The values found were 3.92 and 2.17 mm. per hour respectively, and it is apparent that the catalyst had lost roughly half its activity by this treatment, and hence the true rate constant for carbonyl synthesis at 190°C . will be nearer 30mm. than the previous estimate of 70 mm. per hour.

d. The decomposition of nickel carbonyl in the presence of a nickel Fischer-Tropsch catalyst.

A stream of argon and carbon monoxide (1:1) which/

which contained a constant amount of nickel carbonyl vapour (produced by the bubbling technique described in the experimental section) was passed over the Fischer-Tropsch catalyst at 190°C. and at 5 litres per hour, and the exit gas was then led down the heated decomposition tube. After 30 minutes, the flow was discontinued and the decomposition tube was found to have a nickel deposit.

This procedure was repeated after substituting hydrogen for the argon, but in this case no visible nickel mirror was found on the hot tube.

II.5. Summary.

The results obtained from all the experimental work so far described lead to the following conclusions.

a.

No support has been provided for the results of Mittasch which suggested that $\text{Ni}(\text{CO})_2$ existed as an intermediate in the synthesis of nickel carbonyl.

b.

During a Fischer-Tropsch reaction, either the formation of nickel carbonyl is suppressed or any carbonyl formed is consumed immediately by some process/

process other than decomposition, suggesting that the Fischer-Tropsch reaction either incorporates nickel carbonyl or some intermediate in the formation of nickel carbonyl to such an extent that no carbonyl is present in the effluent gas under the normal conditions for hydrocarbon synthesis.

III.

INVESTIGATIONS USING C¹⁴ TRACER.

III.1. Introduction.

As stated earlier (page 8), the main project in this work was intended to be a variant on the theme of passing Fischer-Tropsch reactants with a small amount of radioactively tagged other substance over a Fischer-Tropsch catalyst and determining how the radioactivity was distributed in the products of the reaction. It had been planned to use C¹⁴ labelled nickel carbonyl in this manner, but on consideration of some of the preliminary work described in section II, it is apparent that the scheme must be modified. The significant points are:-

- 1) Nickel carbonyl is synthesised by passing a stream of argon/carbon monoxide mixture over a Fischer-Tropsch catalyst at 190°C.
- 2) Nickel carbonyl introduced into the above gas stream is decomposed at least partially on passing through the reaction chamber.
- 3) No nickel carbonyl appears in the effluent gas on passing a stream of hydrogen/carbon monoxide **mixture** over a Fischer-Tropsch catalyst at 190°C.

- 4) No nickel carbonyl is present in the effluent gas after passing hydrogen and carbon monoxide containing nickel carbonyl over the catalyst at 190°C.

From this last observation it seems that either all the carbonyl is decomposed into nickel and carbon monoxide, or that some other reaction to form hydrocarbon takes place with either carbonyl or an intermediate of its decomposition. If the latter were the case, then if the nickel carbonyl were labelled with C^{14} , all the C^{14} in the effluent gas should be found in the hydrocarbon fraction and none in the carbon monoxide. If the former were the case, then the C^{14} would appear in the carbon monoxide and also in the hydrocarbon fraction. The quantity of activity in the carbon monoxide would be fixed by the amount of active carbonyl picked up per unit volume of carbon monoxide, and also by the activity of this carbonyl. The amount of C^{14} in the hydrocarbons would be determined by the relative position in the catalyst bed where each reaction took place. For example, if all the carbonyl decomposed in the first centimetre of the catalyst bed, and if all the resultant hydrocarbons were formed in the last centimetre of the bed then the hydrocarbons would contain the same amount/

amount of C^{14} as the carbon monoxide. If the positions were reversed, then the hydrocarbons would have no activity, unless there were C^{14} exchange between the hydrocarbons and the carbon monoxide or the nickel carbonyl. Therefore any degree of C^{14} content from 0% to 100% of the carbon monoxide activity could be found in the hydrocarbons depending on the extent of overlap of the reaction sites. Furthermore, if both complete decomposition and reduction of the carbonyl occurred side by side, the picture would also be obscure, since estimation of the C^{14} content of either the hydrocarbons or of the carbon monoxide will give no information as to what has happened in the reaction bed.

All the same it is possible to distinguish in the following manner between the case where there is no interaction of nickel carbonyl nor of any stage before the final step of its decomposition, to form hydrocarbons, and the case where there is some such reaction.

- 1) By determining the C^{14} content of the carbon monoxide in the effluent gas of a system in which argon and carbon monoxide plus labelled nickel carbonyl are passing over a Fischer-Tropsch catalyst at $190^{\circ}C$.
- 2) Then by comparing this value with the C^{14} content/

content of carbon monoxide from a system of hydrogen, carbon monoxide and the same labelled nickel carbonyl passing over the same catalyst at 190°C.

In such parallel experiments carried out under exactly analogous conditions, if the C^{14} content of the monoxide is less in case (2) than in case (1), it means that not all of the carbonyl has been converted to nickel and carbon monoxide, but that some has been prevented from complete dissociation and has been converted to hydrocarbons.

This comparison will be valid only if no C^{14} exchange occurs between

- 1) Carbon monoxide and hydrocarbons.
- 2) Nickel carbonyl and hydrocarbons.
- 3) Nickel carbonyl and carbon monoxide before entering the reaction bed.

The programme was therefore modified to

- 1) Making the appropriate experiments to give the above comparison.
- 2) Checking the validity of any conclusions by investigating whether any of the secondary exchange reactions take place or not.

III.2. Preparation of radioactively labelled materials.

The C^{14} radioactive carbon monoxide was prepared from C^{14} active sodium formate supplied by the Radiochemical Centre, Amersham, and the labelled nickel carbonyl was in turn prepared from this carbon monoxide. Full details are given in the experimental section.

III.3. Exchange reactions.

3.a. Exchange between carbon monoxide and methane.

With the ballast bulbs isolated, the cycling apparatus was evacuated and then filled to a known pressure with C^{14} labelled carbon monoxide. Methane was next admitted to the system, again to a known pressure. The gas mixture was then cycled round the apparatus by means of the circulating pump, passing through the normal reaction vessel (no catalyst was present), at $190^{\circ}C$. After circulating for 48 hours at 5 litres per hour (at least 50 complete cycles) a sample was drawn off and the C^{14} content of the carbon monoxide compared with the original value. Since they were found to be identical (within 1%), this experiment shows that/

that no significant exchange of C^{14} takes place between carbon monoxide and methane under these conditions.

This run was repeated but having in addition a nickel Fischer-Tropsch catalyst present in the reaction vessel. Again no exchange took place. Since slight amounts of nickel carbonyl are produced under these conditions, this experiment suggests also that under Fischer-Tropsch conditions there is no exchange of C^{14} between hydrocarbons and nickel carbonyl.

3.b. Exchange between nickel carbonyl and methane.

Pure methane was circulated round the cycle which contained a nickel catalyst at $190^{\circ}C$. Before entering the reaction vessel, the gas was bubbled through some radioactive nickel carbonyl and then through a cooled trap which ensured that a fairly constant amount of carbonyl was entering the reaction vessel. The gas was cycled for 5 hours at 1 litre per hour and then a sample was drawn off and the methane examined for radioactivity. As far as could be seen there was no activity present, the methane sample giving only the normal background count on estimation.

In both these exchange experiments the methane and the carbon monoxide were separated by absorption of/

of the latter in ammoniacal cuprous chloride solution.

3.c Exchange between carbon monoxide and nickel carbonyl.

c.1. Cycling a mixture of radioactive carbon monoxide and inactive nickel carbonyl vapour through the empty reaction vessel at 190°C. resulted merely in the decomposition of the latter and subsequently in the dilution of the active carbon monoxide with inactive monoxide.

c.2. A repeat of the previous run at room temperature but with a nickel Fischer-Tropsch catalyst present in the reaction vessel, showed after 12 hours that although radioactive nickel carbonyl had been formed (fall in pressure within the system of nearly 40 mm. of mercury), there was no loss of activity in the carbon monoxide since its counting rate remained the same as it was originally. For the purpose of this estimation it was freed from nickel carbonyl by means of immersing in a liquid oxygen bath for ten minutes.

c.3. To speed the process up a static system was used in which all the gas was maintained at the reaction temperature all the time, instead of part at a time as was the case in the previous runs. A glass bulb fitted with a/

a capillary lead, was filled with C^{14} carbon monoxide and inactive nickel carbonyl - each to a known pressure. The bulb was immersed in liquid oxygen to freeze the carbonyl, and then a sample of the carbon monoxide was transferred into the gas counter and its radioactivity was measured, after which it was returned to the bulb.

The bulb was next immersed in a thermostat at $35^{\circ}C$. for 12 hours, and then after immersion in liquid oxygen once more, the pressure and the activity of the monoxide were determined. The monoxide was found to have lost 9% of its activity although there had been no rise in its pressure, showing that no overall decomposition of the carbonyl had taken place and therefore that exchange of C^{14} had taken place between the nickel carbonyl and the carbon monoxide.

This experiment was repeated at $57^{\circ}C$. It was found that after 12 hours, exchange had taken place to 100% of the possible extent, although again no overall decomposition of the carbonyl had occurred. This conclusion was verified by pumping off all the carbon monoxide, allowing the nickel carbonyl to warm up, heating the bulb in a flame to decompose the carbonyl, recooling in liquid oxygen and estimating the activity/

activity of the carbon monoxide produced. This activity was found to agree with the expected value calculated after assuming that the maximum possible exchange between carbon monoxide and carbonyl had taken place.

Another repeat showed that the same extent of exchange had occurred in an hour. It was found in a further experiment that 57% of the possible exchange had taken place in 6 minutes, and that after another 4 minutes 85% had been reached. In none of these cases did any overall decomposition occur.

III. 4) Summary.

These experiments therefore show that only the exchange of C^{14} between carbon monoxide and nickel carbonyl was likely to interfere with the Fischer-Tropsch investigation, but all the same, such an exchange does not make the investigation pointless, since its only effect would be to reduce the possible difference in C^{14} content of the effluent carbon monoxide between the run with argon and the run with hydrogen. If the rate of flow is fast enough, it is possible that the amount of exchange taking place before decomposition or hydrocarbon synthesis sets in, will be negligible.

A further outcome of this piece of work is that a convenient method of preparation of C^{14} labelled nickel carbonyl has been found.

III. 5. Tracer investigation of the Fischer-Tropsch reaction.

A nickel Fischer-Tropsch catalyst was prepared and tested in the reaction vessel by circulating a mixture of carbon monoxide and hydrogen over it; the fall in pressure with time gave evidence that reaction had taken place.

A stream of argon and carbon monoxide was then led through the pick-up bubbler where it was saturated with C^{14} labelled nickel carbonyl. After passing through a cooled trap where the nickel carbonyl content was reduced to a known constant value, the gas stream was led over the catalyst at $190^{\circ}C$. A suitable length of time (10 minutes) was allowed for development of a steady state, then a sample of the effluent gas was taken and the run was discontinued.

This process was repeated under identical conditions except that the argon was replaced by its equivalent of hydrogen. A sample of the effluent gas was again taken. The C^{14} content of the carbon monoxide of both samples was then estimated and the results compared.

The two runs were repeated.

The results are shown in the table below and they establish that the C^{14} content of the carbon monoxide effluent from the Fischer-Tropsch reaction was less than that of the carbon monoxide effluent from the argon containing system, and therefore it can be concluded that either nickel carbonyl or one of the stages intermediate in its decomposition can take part in the Fischer-Tropsch synthesis.

Table III.1.

Litres/hour (CO)	Litres/hour (H ₂)	Litres/hour (A)	Activity of CO cts./min.
4.71	0.0	4.96	371
4.71	4.97	0.0	344
4.71	0.0	5.00	376
4.71	5.00	0.0	336

III.6. Final conclusions.

The material presented in sections II and III leads to the conclusion that there is some link between the synthesis and the decomposition of nickel carbonyl and the Fischer-Tropsch reaction and it is highly probable that they have a common intermediate. Unfortunately it has not proved possible to establish the exact nature/

nature of this intermediate although the possibility exists that it is Ni(CO) in which case this work has accomplished little towards elucidating the mechanism of the Fischer-Tropsch reaction beyond producing evidence which is in agreement with the normally assumed first step of

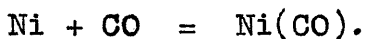

The work has however shown that there is no evidence for synthesis of nickel carbonyl taking place via Ni(CO)₂ as claimed by Mittasch and that C¹⁴ labelled nickel carbonyl can be made rapidly in a relatively simple manner by exchange between nickel carbonyl and C¹⁴ carbon monoxide.

Introduction.

Because radioactive materials have become more readily available in recent years the techniques for estimating radioactivity, particularly where weak beta-rays are involved, have been much studied and improved. In the case of C^{14} where the emitted beta-particle has only a small energy, it is necessary for the counter to have a very thin window, or better still, no window at all, so that the particle can penetrate into the active volume of the counter and hence the efficiency and accuracy of the assay has been much increased by putting the C^{14} into the counting tube itself, as carbon dioxide gas.³³ This method is claimed to be the best³⁴ but unfortunately it requires a power supply unit capable of giving up to 4,000 volts and since during the recent work, the equipment available had a maximum output of 2,000 volts, a search was made for an alternative technique for accurate estimation of the C^{14} content of materials.

Since the C^{14} used in the tracer work of this thesis was, at one time or another, in the form of a carbon monoxide gas, experiments were made to see if this gas/

GAS COUNTER

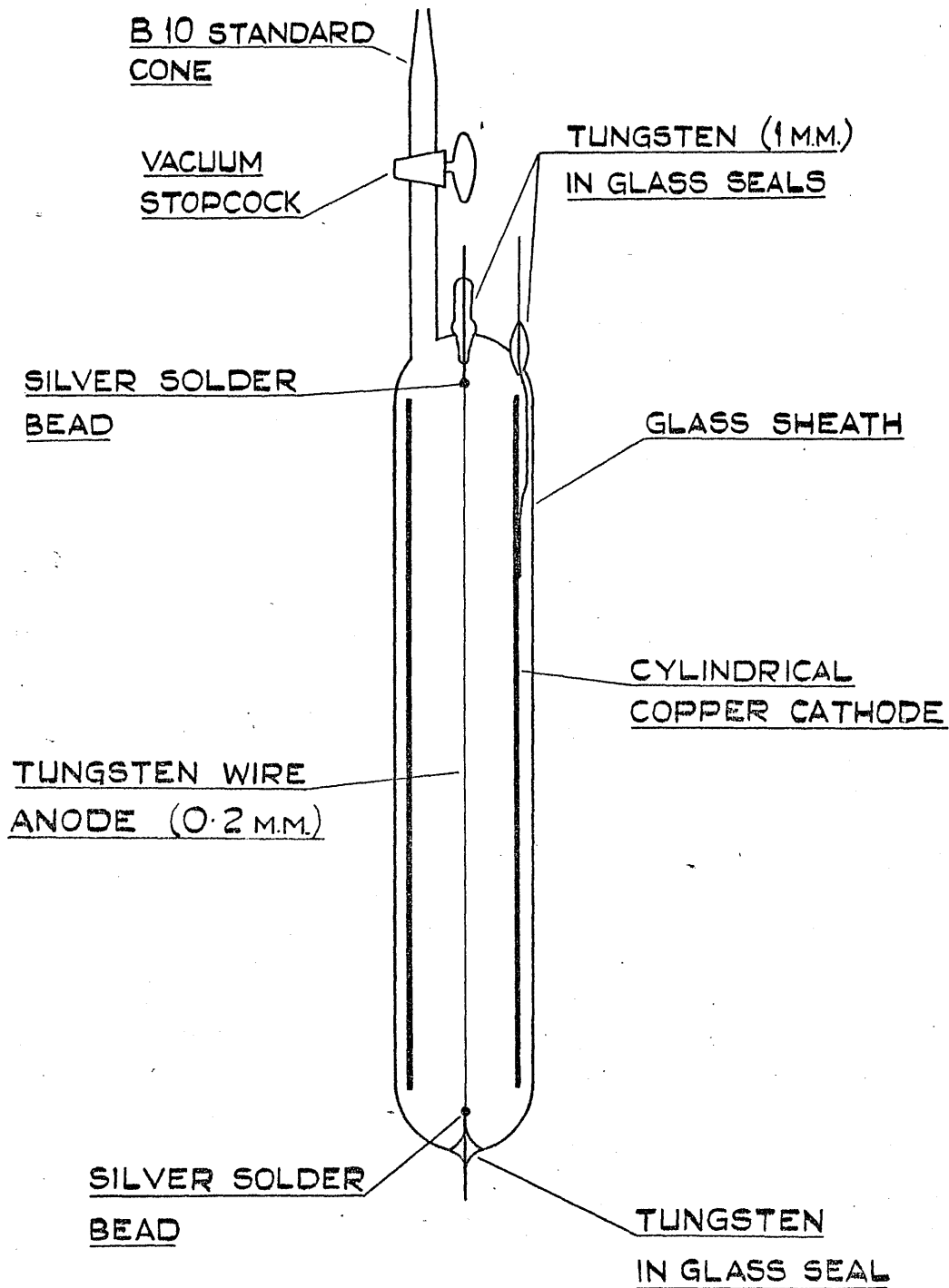

gas could act as a counter filling or as a minor constituent. These proved disappointing and it was decided to use an ordinary thin end-window counter and barium carbonate as the counting source. A very successful method was developed, but since the technique was intrinsically laborious and time consuming, an alternative method was developed in which the C^{14} was in the form of a gas but was estimated with an end-window counter.

2. Carbon monoxide as a gas counter filling.

a. The counting tube.

A conventional gas counter as shown in the figure opposite was constructed by sealing a cylindrical copper cathode (19 mm. internal diameter, 1 mm. thick and 10 cms. long) and a tungsten wire anode (0.2 mm. diameter) into a glass sheath which was fitted with a vacuum stop-cock and a standard ground glass joint for attachment to the filling manifold. After filling with a mixture of argon (90 mm.) and ethyl alcohol vapour (10 mm.) it was tested by determining the curve of counting rate against applied voltage. (cf. figure 13 overleaf) using an external source of radioactivity, and was found to give a readily reproducible plateau over 100 volts long and with a slope/

FIGURE 13

CHARACTERISTIC CURVES FOR COUNTER.

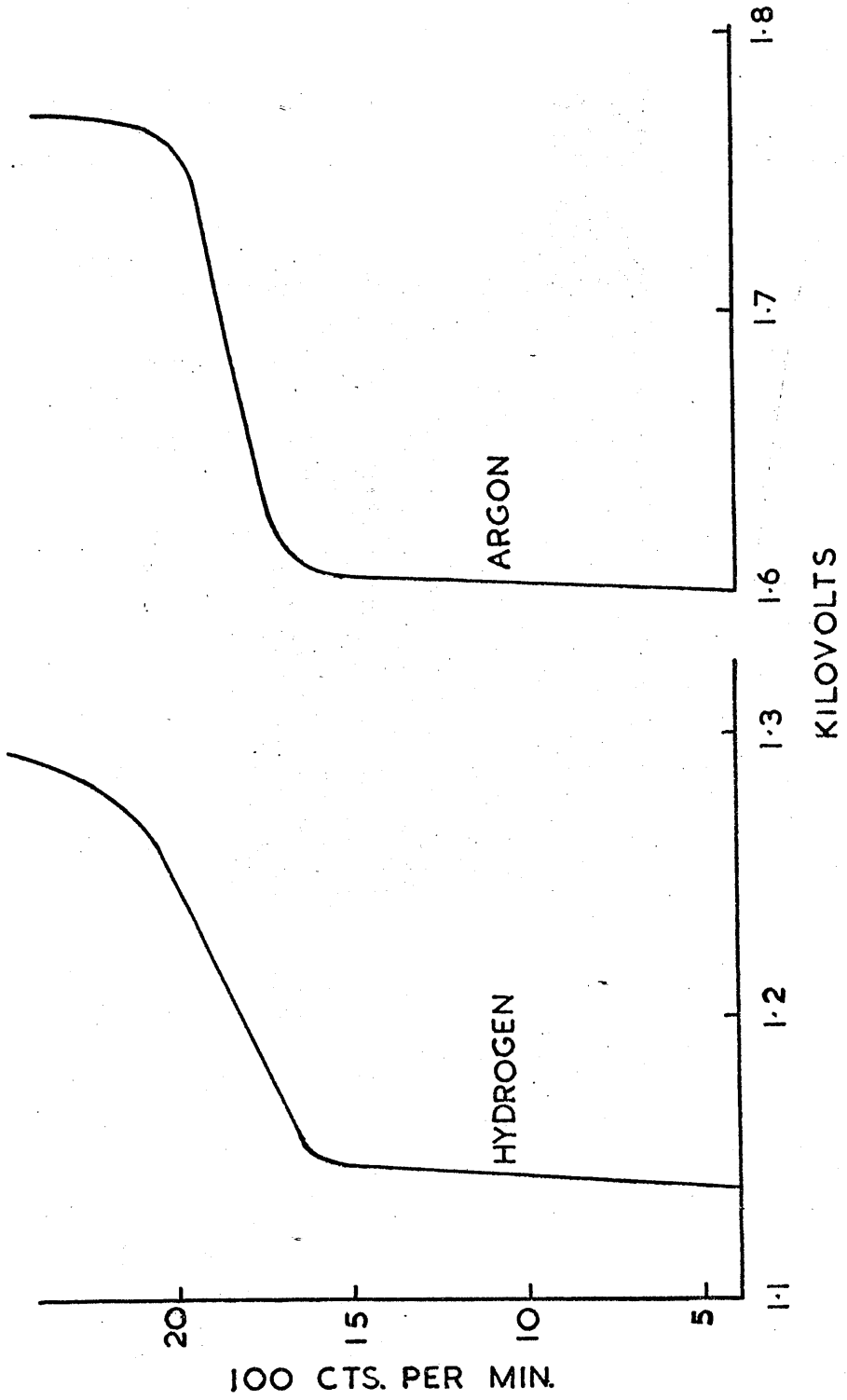

slope of less than 10% per 100 volts. The tube was then evacuated and refilled with a mixture of hydrogen (82 mm.) and ethyl alcohol (18 mm.) The characteristic curve was determined and again a plateau was observed, although in this case the slope was rather large (20% per 100 volts).

On this evidence, the counter was judged to be satisfactory.

b. Filling with carbon monoxide.

Since carbon monoxide has a similar ionisation potential to carbon dioxide, (14.2 and 14.4 electron volts respectively), it was suspected that pure carbon monoxide would prove unsuitable as a gas counter filling to work below 2,000 volts. Nevertheless experiments were made as outlined below, since such a counter if workable, would prove very valuable, but none of the fillings gave rise to a counter with any function at all within the required voltage range.

Normally ethyl alcohol and carbon disulphide are added to act as quenching agent and charge transfer agent respectively, but in these experiments they were added to see if they also had the property of lowering the working voltage, as carbon disulphide does in carbon dioxide filled counters.

Table IV.1. Fillings tested for counting action.

Mixture	Pressure of CO (mm.)	Pressure of EtOH (mm.)	Pressure of CS ₂ (mm.)	Counting rate.
1	100	0	0	0
2	50	0	0	0
3	25	0	0	0
4	99	10	0	0
5	74	4	0	0
6	51	3	0	0
7	25	1	0	0
8	91	0	10	0
9	60	0	6	0
10	30	0	3	0
11	90	7	4	0

In each case the filling was tested for counting action from 0 to 2,000 volts using an external Co⁶⁰ source of radioactivity.

c. Carbon monoxide as a minor constituent of the filling.

The following experiments were carried out to see if a small amount of carbon monoxide gas, which could be measured accurately by means of a gas pipette and/

and an expansion bulb, could be introduced into a normally filled counter without seriously disturbing its counting characteristics.

The characteristic curve of the counter filled with argon (91 mm.) and ethyl alcohol vapour (10 mm.) was determined, and as before, a starting voltage of 1,610 volts followed by a plateau 100 volts long with a slope of 8% per 100 volts was observed. After a small amount (ca. 1 mm.) of carbon monoxide was introduced into this counter, the curve was redetermined, but in this case the counter did not record until 1,925 volts, and continuous discharge set in immediately.

This procedure was repeated using hydrogen (82 mm.) and ethyl alcohol (18 mm.) alone and then with carbon monoxide (1 mm.) in addition. Here again the plateau was destroyed and the starting voltage rose from 1,150 to 1,450 volts, and the counter registered 57,000 counts per minute at this voltage in comparison with 731 counts per minute for the carbon monoxide free system at its starting threshold.

The reason for this destruction of the plateau by carbon monoxide could be related to the similarly poor counting properties of carbon dioxide. When the latter is used alone in the gas phase assay of C^{14} , the lack/

lack of plateau is attributed to the formation of negative ions from the CO_2^+ ions as the latter approach the cathode. These CO_2^- ions are then repelled back towards the central anode, giving rise to spurious pulses which are highly deleterious to counter action. This effect can be counteracted however, by adding to the filling another substance which has a lower ionisation potential than carbon dioxide and which neutralises the CO_2^+ ions by electron transfer on collision, forming positive ions itself, which are then neutralised by the cathode without formation of negative ions, and therefore without developing spurious pulses. This second substance is known as a charge-transfer agent, and for carbon dioxide gas there is a choice of many vapours, all of which show the desired effect. Carbon disulphide is acknowledged to be the best³³, and since it was suspected that negative ion formation might be the cause of the spurious discharges developed in the argon/ethyl alcohol/carbon monoxide system, experiments were made to see if the addition of carbon disulphide to this mixture would result in the development of a plateau, since the ionisation potentials of carbon monoxide and the disulphide are favourable for the charge transfer process to occur (14.4 and 10.4 electron volts respectively).

Table IV.2. Effect of adding a charge-transfer agent.

Filling	1	2	3	4	5	6
Argon (mm.)	102	90	90	90	80	80
Ethyl alcohol (mm.)	7	11	11	11	5	5
Carbon monoxide (mm.)	18	10	5	1	1	1
Carbon disulphide (mm.)	6	2	2	2	4	4
Plateau length (volts)	25	25	25	40	40	40
Plateau slope (% per 100 volts)	75%	80%	75%	120%	100%	200%

These results show that the addition of carbon disulphide had some effect in improving the counting properties of the system argon/ethyl alcohol/carbon monoxide by lengthening the range of volts between starting voltage and continuous discharge voltage, but in none of the above cases was the plateau developed sufficiently long or sufficiently flat to be usable in gas counting. Permutation of the variable amounts of constituents of the filling, and use of some other charge-transfer agent (e.g. acetone), might result in a system suitable for gas counting, but it was realised that such a development would be fortuitous and it seemed best to abandon this approach at least temporarily, and tackle the problem of C^{14} estimation from the other angle viz.- solid counting.

IV.3. Solid counting.

a. Introduction.

Since solid counting suffers from the handicaps of self-absorption and back-scattering effects, it is normal to convert all samples to barium carbonate, thus keeping the back-scattering factor constant, and to count either at "infinite thickness" or to determine a self-absorption curve of counting rate against thickness of sample.

A further problem arises in the preparation of a uniform surface on the sample, for unless it is smooth and unbroken, a false count will be obtained. Various attempts which were unsuccessful were made to obtain consistent results, before a satisfactory method was developed.

b. Preparation of homogeneous active barium carbonate.

Before valid comparison of one assay with another could be made, it was necessary that the samples should be of homogeneous material, otherwise deviation could be due to differing amounts of C^{14} in the barium carbonate and not necessarily to inaccuracies in the technique. For this reason, the barium carbonate used in the next section of the work was prepared in a homogeneous form as described in the experimental section.

c. Preparation of the counting surface.

c.1. Suspensions.

An adaptation of the method outlined by Kamen³⁶ was used. Barium carbonate was suspended in a liquid medium in as finely dispersed condition as possible, transferred by dropper onto a suitable surface and the "solvent" evaporated, leaving a barium carbonate layer. The layer was gradually built up to the required thickness by successive repetitions of this process.

Water, ethyl alcohol, methyl alcohol, acetone, ether, cyclohexane, and benzene were used in an attempt to get maximum accuracy. In each case, nickel planchettes, glass, and filter paper squares were used in turn as the surface, and the method of evaporation was varied (heating over a flame, under a lamp or, where applicable, simple evaporation at room temperature).

In spite of these variations, even the best results (from an ether/ethyl alcohol suspension on a nickel planchette), were far from satisfactory, giving deviations of up to 5%, as can be seen from the table of results in the experimental section (page 141), and improving only slightly with practice. Visibly good surfaces could only be prepared at low thicknesses of up to 4mg./sq.cm., and attempts to build up to infinite/

infinite thickness inevitably resulted in flaking, pitting or cracking.

Other workers have recorded similar deviations in solid counting of barium carbonate.³⁷

c.2. Pastes.

Since it was felt that the addition of later drops of suspension broke up the layers of barium carbonate already deposited and caused the above failures, attempts were therefore made to prepare the barium carbonate layer in one operation.

A paste of carbonate in ether/ethyl alcohol was placed in a planchette, smoothed by means of a nickel spatula, and dried, but here again the surface broke up and the counts made still showed a large deviation from sample to sample (up to 4%).

c.3. Filtering.

The barium carbonate suspension was filtered by suction through a sintered glass crucible and the precipitate dried and counted. Trouble arose from the tendency of the solid to stick to the walls of the crucible. These were made removable, but the counting accuracy was still low, deviations of 4% being quite common, especially with the thicker layers of precipitate

Table IV.3.

Sample number	Total count	Time in seconds	Counts per minute	Calculated standard deviation (%)	Observed %age deviation from mean
n	N	t	$\frac{60N}{t} = A_n$	$\frac{100}{N} \sqrt{N}$	$\frac{100(A_n - x)}{x}$
1	51423	3120	988.9	0.44	0.78
2	52466	3180	989.9	0.44	0.67
3	51455	3120	989.5	0.44	0.71
4	51567	3120	991.7	0.44	0.49
5	56029	3360	1000.5	0.42	0.53
6	48884	2940	997.6	0.45	0.08
7	52039	3120	1000.7	0.44	0.55
8	56934	3420	999.8	0.42	0.35
9	52173	3120	1003.3	0.44	0.71
10	60173	3600	1000.9	0.41	0.67
11	62961	3780	999.4	0.40	0.31
12	59920	3600	998.7	0.41	0.24
13	69405	4200	991.5	0.38	0.51
14	54826	3300	996.8	0.43	0.04
15	139585	8400	997.0	0.28	0.06
16	59486	3600	991.4	0.41	0.52
17	50011	3000	1000.2	0.45	0.50
18	51769	3120	995.6	0.44	0.08
Average	60062	3617	996.4	0.42	0.43

$x = \text{Total of all } A_n \text{ divided by } 18 = 996.4$

If, however, the precipitate was pressed while still wet, with the hot smooth end of a rod of suitable diameter, the layer did not break up on drying, and results could be obtained to within 2% of each other.

c.4. Pressing.

The success of the pressing experiments in the last section, suggested an attempt to prepare highly compressed pellets of barium carbonate, which might prove very suitable for counting, using a press capable of applying 10 tons per square inch to a powdered material in a die which has polished metal circular faces, thus converting the material to a compact mass, with extremely smooth surfaces. Furthermore the pellet could be counted without removal from the die, which acted as a support thus giving constant smooth surface areas and constant geometry for counting by mounting the die in the same position for each assay. Details of the press are given in the appendix

Barium carbonate is not a good pressing material, but after only a little practice, results which agreed with statistically correct accuracy as shown in the table opposite, were obtained for estimations of the C^{14} content of different samples of the same barium carbonate.

Eighteen different assays were made, and in each case the percentage deviation of the observed count rate from the mean count rate (total of all eighteen count rates divided by eighteen) was noted, and then compared with the standard deviation for the count (the square root of the individual total count expressed as a percentage of this count). When allowances are made for the random nature of all radioactive counts, this comparison shows that the method employed in the assay is excellent. Further proof comes from the fact that the mean of the calculated theoretical standard deviations was 0.42%, whilst the mean of the observed deviations was 0.43%. In effect, better results would be impossible to realise.

Since 150 mg. or more of material are required to prepare a sample, and since the surface area produced is 1.266 sq.cms., the sample must have a thickness of 120 mg./sq.cm. which is well in excess of "infinite thickness" (20 mg./sq.cm.), and therefore valid comparison of the activity of one material with another can be made simply by comparing the counting rates of their respective pellets.

The figures of Anderson, Delabarre, and Bothner-By are quoted overleaf to show that the pressing technique is evidently superior.

Anderson, Delabarre, and Bothner-By.

Reproducibility of the estimation of a sample prepared by a filtering technique.

Counts per minute	1241	1269	1252	1249	1229	1272
%age deviation	0.9	1.4	0.0	0.2	1.8	1.6

- - - - -

The one drawback to this method is that the amount of material necessary is fairly large (150 mg.), especially when compared with the 5 mg. to 10 mg. which is sufficient for many methods of gas phase assay. Otherwise the pellet pressing technique is excellent, since it gives maximum accuracy, is simple and rapid in operation, and moreover is obviously applicable to many other materials, especially organic substances, and to other radioactive isotopes such as S³⁵ in sulphates or in organic sulphur-containing compounds, the only criterion being that the substance should be able to withstand the application of a large pressure. This means that in the estimation of the C¹⁴ content of organic materials, the compound itself could be pressed and counted, thus eliminating the need for combustion and conversion to barium carbonate. Such results, however would only be accurate if the back-scattering effects of different compounds were previously/

previously compared and a conversion factor calculated. This factor could be obtained by comparing the counting rate of a homogeneous mixture of the one substance and a C^{14} active compound with the counting rate of a homogeneous mixture of the other substance with the same percentage content of the C^{14} compound.

d. Extension to smaller amounts of barium carbonate.

The suggestion for obtaining conversion factors in the last section was also applicable to the estimation of amounts of active barium carbonate which were less than the 150 mg. required for pressing. This idea was merely to add an inert filler to give the necessary bulk to the carbonate and apart from inactive carbonate itself, the obvious material to use was potassium chloride since the press was designed for this substance. The necessary homogeneity could be produced by thorough grinding of the mixture.

d.1. Reproducibility.

A mixture of active barium carbonate and potassium chloride (AnalaR) was made with 76.7% of carbonate by weight, and ground thoroughly until homogeneous. A pellet/

pellet was pressed and the counting rate was determined. This same pellet was then extruded from the die and reground to a fine powder which was then repressed and recounted. This procedure was carried out six times in all, and the counting rates of each pellet noted and compared with the others. As can be seen from the table (case A), the results are highly satisfactory, the reproducibility also serving to show that the material had been made homogeneous by grinding, otherwise the count rate would have altered with further grinding.

Table IV.4. Reproducibility - Series A.

Pellet number	Counting rate (cts/30 mins)	Average count	%age deviation from mean.
1	22,931	22,871	0.3%
2	22,994	22,871	0.6%
3	22,954	22,871	0.4%
4	22,766	22,871	0.6%
5	22,816	22,871	0.3%
6	22,712	22,871	0.8%

Another sample of the same mixture was then taken and the above procedure applied to it, giving the results shown overleaf (case B).

Table IV.5. Reproducibility - Series B.

Pellet number	Counting rate (cts/30 mins)	Average count	%age deviation from mean.
1	22,107	21,850	1.5%
2	21,759	21,850	0.5%
3	21,910	21,850	0.3%
4	21,807	21,850	0.2%
5	21,925	21,850	0.4%

- - - - -

The first count rate was significantly higher than the others and was probably in error caused by insufficient grinding and subsequent non-homogeneity. (The average count rate quoted above is the average of pellets 2, 3, 4, and 5.) However this average was almost 5% lower than the average count rate of the previous series A. The reason for this was suspected to be that, although the material had been left covered overnight, it had not been kept in a vacuum desiccator between series A and B, and hence either the active carbonate had exchanged C^{14} with the atmospheric carbon dioxide and lowered the C^{14} content of the mixture, or else water vapour had been taken up by the potassium chloride and hence the percentage by weight of C^{14} would be less.

This theory was proved by making a fresh mixture of/

of active barium carbonate and potassium chloride, counting, extruding the pellet from the die, grinding and recounting as a check for homogeneity, reconverting to a powder which was left exposed overnight and then recounting. (Series C, pellets 1, 2, and 3, respectively) The powdering, exposing overnight, and recounting was repeated twice. An apparent daily loss in counting rate could be seen from the results.

Table IV.6. Series C.

Pellet number	1	2	3	4	5
Total count in 30 mins.	22,387	22,247	21,965	21,740	21,572

- - - - -

After another week, the counting rate was found to be 20,940 counts per 30 minutes. The pellet was again expelled and reground, but before recounting the mixture was heated at 110°C. for an hour and then recounted immediately, giving 22,192 counts per 30 minutes i.e. the counting rate was restored to its original value (1 and 2), and hence it would appear that water vapour absorption was responsible for the fall off in counting rate. The obvious way to overcome this effect was to use an inert "filler", which is unaffected by water vapour, but it was found that if the potassium chloride used were taken straight from the bottle and was not dried before use, then the day to day effect of water vapour on/

COMPARISON OF OBSERVED
WITH KNOWN ACTIVITY

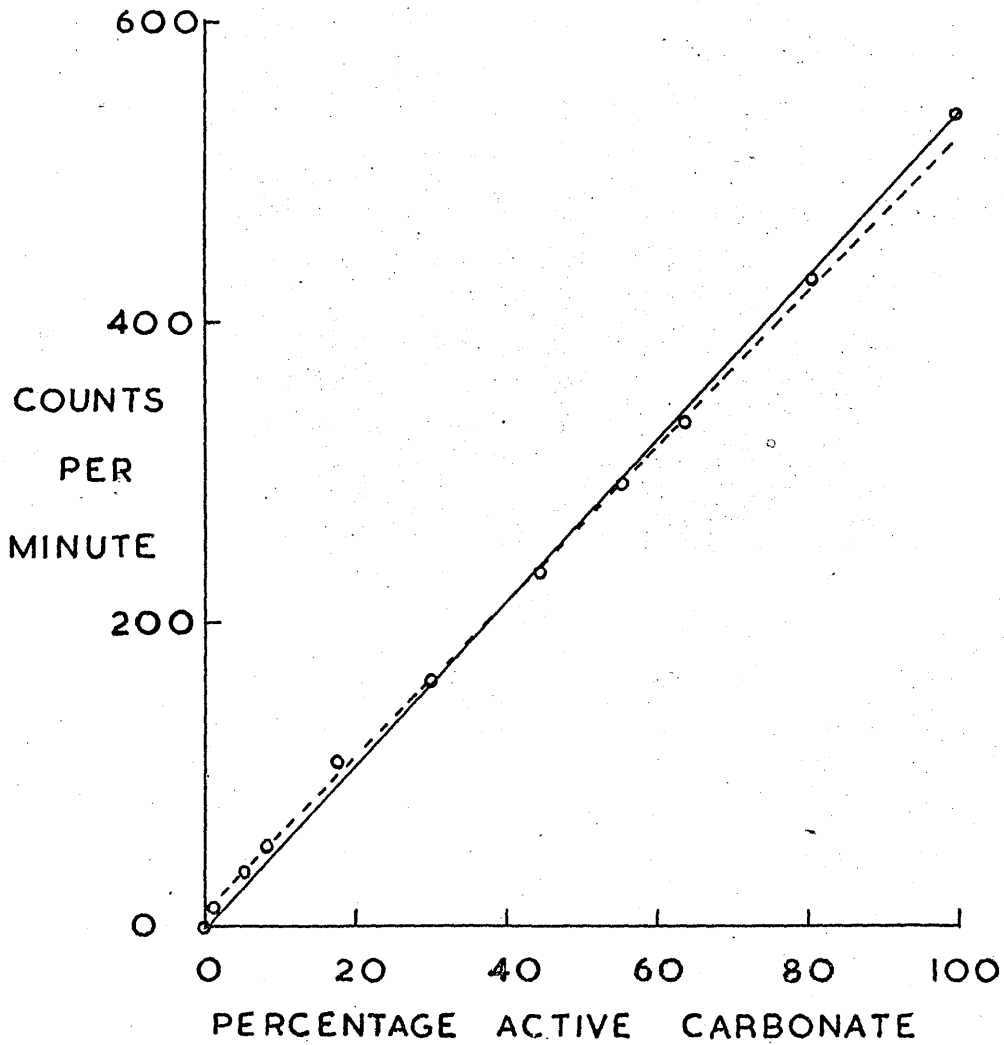

FIGURE 16

on the counting rate of any sample was negligible.

Table IV.7. Reproducibility using undried potassium chloride.

Pellet number.	1	2	3	4
Counts per 30 minutes.	22,387	22,149	22,236	22,257
Exposure time in hours.	0	24	48	120

- - - - -

d.2. Variation of counting rate with the percentage of active barium carbonate in the material.

Although it would be expected that the counting rate of a mixture of active barium carbonate with another material would be directly proportional to the percentage of the active carbonate in the material, experiments were still made to verify this by determining the counting rate of different mixtures of active barium carbonate and potassium chloride made by direct weighing and hence of known percentage composition.

The results are represented graphically (opposite), and can be seen to agree fairly well with theory, although the "best straight line" (shown as a broken line) suggests that the counting rate of pure barium carbonate should be 520 per minute as opposed to the observed value of 537 per minute. This could well be due to differences

SYNTHESIS OF COUNT RATE FROM COMPONENTS

FIGURE 17

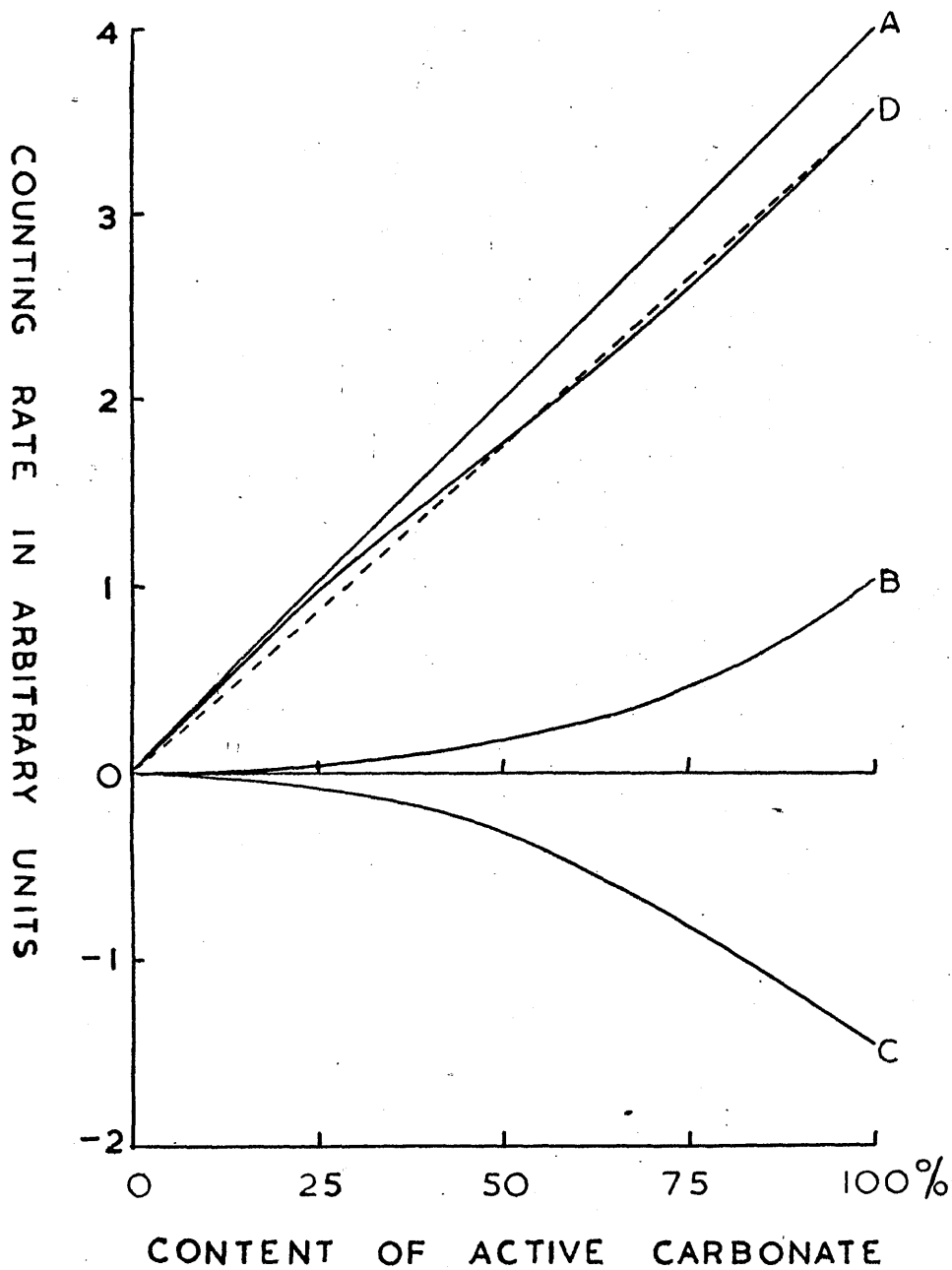

differences in the self-absorption and the back-scattering of the samples as the percentage composition varies. Because of the relatively heavy barium atom present in the carbonate, both of these factors would be expected to be higher for the carbonate than for the potassium chloride, and hence as the proportion of the carbonate rises, the amount of backscattering and self-absorption in the material must also rise. The two effects oppose one another but unless by coincidence they cancel each other there will always be a small residual effect.

The simple diagram opposite illustrates how the combination of these two effects could give rise to a curve similar to that observed. The theoretical plot is drawn of what the counts per minute against percentage active component would be in the case where no back-scattering nor self-absorption had yet taken place, (line OA). The additional counts per minute caused by back-scattering are shown, (line OB) - this is not a constant proportion of the total counts since the composition and hence the back-scattering factor of the material is altered, the percentage of counts gained rising as the percentage of the heavier component of the mixture rises. Similarly the counts per minute lost by self-absorption are shown (curve OC), and/

and they also are not a constant fraction of the total since the self-absorption coefficient of the material likewise varies with the percentage composition. The combination of these three components would give the curve of the observed counts per minute against percentage composition (curve OD). As can be seen, this curve lies above the broken straight line OD along its lower half and then falls below it slightly. Although these curves are purely hypothetical, this is exactly the shape observed for the potassium chloride/active barium carbonate mixtures, and they give a reasonable explanation as to how it arose.

The possibility existed however that the deviations from linearity in figure 16, page 98, were due to experimental errors. By making counts on each of four mixtures made separately but of the same composition, the variation caused by inadequacies in the technique was found, and although the results (see table IV.8. overleaf) showed that the possible error was large (up to 7%), all the points produced lay above the line drawn from the origin to the observed value for 100% barium carbonate, suggesting that the observed curve is a true representation of what occurs.

Table IV.8. Experimental error.

Wt. of BaCO ₃ (mg.)	16.1	16.1	16.1	16.1
Wt. of KCl (mg.)	181.9	181.8	181.9	181.9
%age BaCO ₃	8.13	8.13	8.13	8.13
Cts./min.	50.9	53.2	48.5	49.7
% deviation	1.8	6.5	3.0	0.7
Calcd. rate 100% BaCO ₃	626	654	597	611
Observed rate 100% BaCO ₃	537	537	537	537

The larger deviation of 6.5% is possibly caused by insufficient grinding or by the natural limitation of the accuracy of a radioactive estimation when the counting rate approaches that of normal background (16 counts per minute) as is the case here.

The above experiments show that extension of the pellet pressing technique to smaller amounts of active carbonate is accompanied by a loss in the accuracy of the estimation in the case where a mixture of materials is involved. Accuracy could be improved by determining a calibration curve to allow corrections to be made for variations of scattering and absorbing properties of the mixtures, or by using the inactive form of the substance itself as a "filler". In either case there is no way of preventing the loss of accuracy inherent in the process/

process of dilution other than by counting for much longer lengths of time.

IV.4. End-window gas counting.

Since for solid counting all samples must be burned and then converted to barium carbonate, the process is naturally time consuming and wasteful, for conversion of the sample back to its original state, if required, could be a difficult task. It was to avoid this expenditure of time and material that experiments were made with C^{14} gas-filled counters, (unsuccessful - see subsection 2 of this chapter.) However an unexplored possibility is that samples of gas could be estimated with an end-window counter simply by sealing the window into a cell, which could be evacuated and filled to a known pressure with the gas which could then be assayed. Such a counter has the attractions that it should function with any gas containing a radioactive isotope, that the transfer of gas into the cell would be simple and rapid if the cell were attached to the reaction system by means of a Topley pump, and, if desired, the gas could easily be reclaimed using this same pump to put it back into the system.

Experience already gained in counter construction suggested that making an end-window counter should be fairly simple, although if used for the above purpose, the decisive factor would be whether a window could be found suitably thin for C^{14} estimation (ca. 2 mg./sq.cm.) that would survive the strain of continual fluctuations from zero to almost one atmosphere in the pressure upon it. Trial showed that mica was too easily broken, but MELANEX film survived many pressure changes without breaking, although it stretched irreversibly under fairly small pressure differentials, interfering with the counting tube by displacing the anode and hence required the additional support of a grid made from a few crossing nickel wires.

The essential details of this counter construction are given in the appendix.

b. The counter filling.

Experiments were made to decide the ratio of ethyl alcohol to argon and the total pressure of gas filling which gave rise to the best counting characteristics.

By filling the counter to the same total pressure but with varying percentages of ethyl alcohol in the mixture, then determining the curve of the counting rate/

FIGURE A

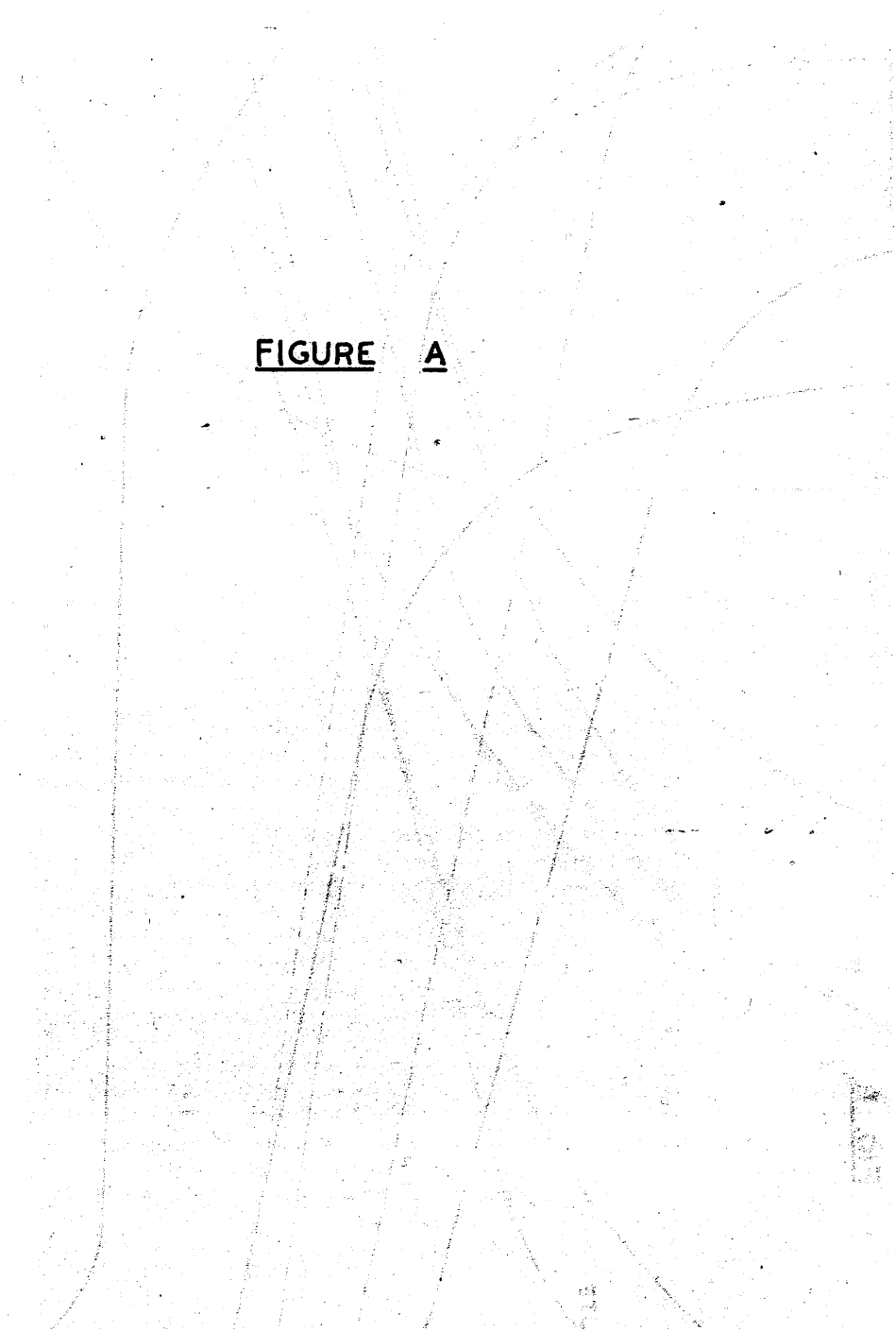

EFFECT OF VARYING ETOH/A RATIO

FIG. A

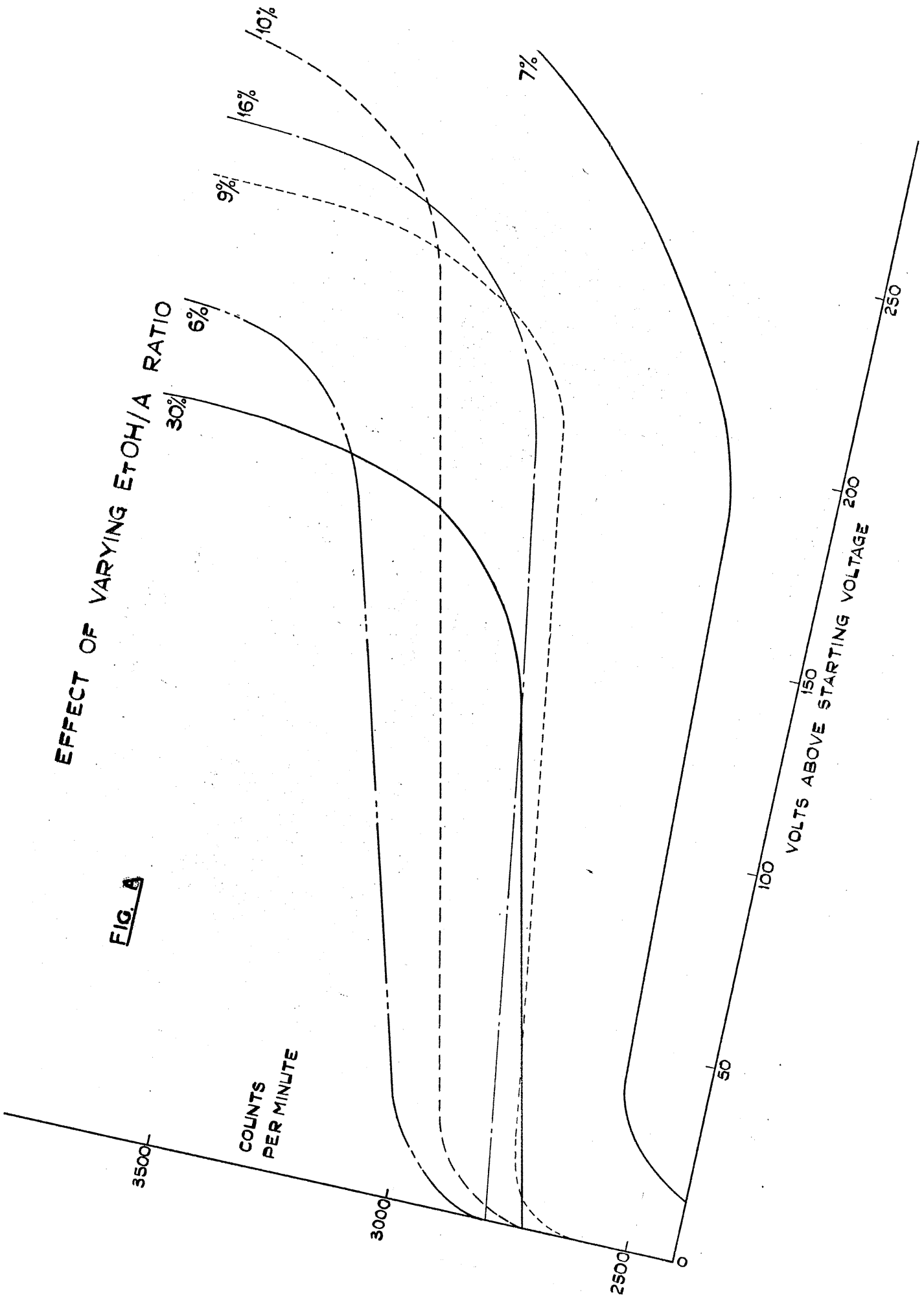

COUNTS
PER MINUTE

FIGURE B

EFFECT OF VARYING PRESSURE

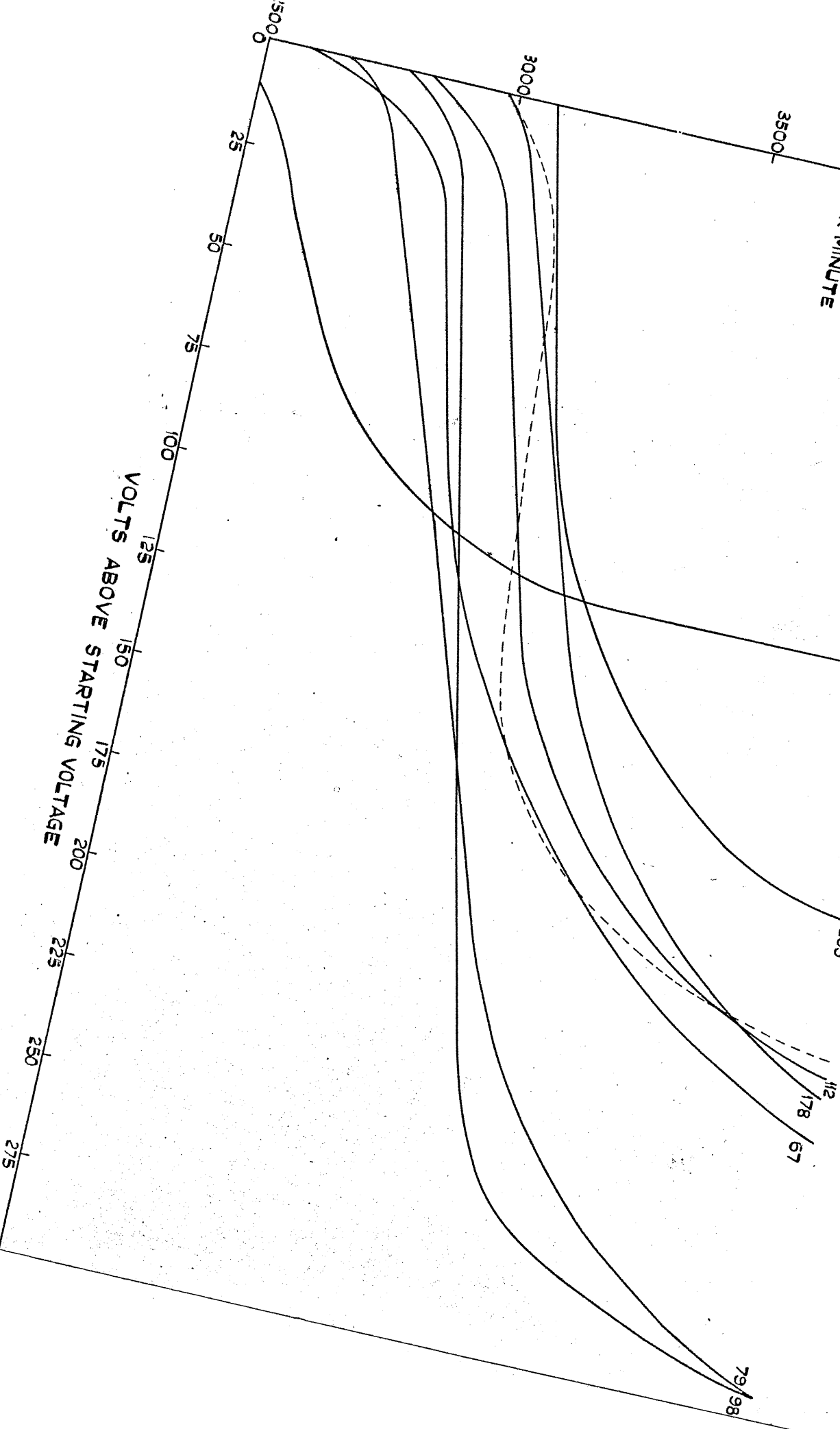

FIGURE B

rate of a Co^{60} source against applied voltage and comparing the lengths and slopes of the plateaus formed, the best ratio was found. This value (between 9 and 16% ethyl alcohol) compared well with the normally used 10% alcohol. Some typical curves are shown in figure A where it can be seen that the actual ratio present has only a limited effect on the counting characteristics and hence it is by no means a critical factor.

In a similar manner, by determining the dependence of the counter on the internal pressure of an alcohol/argon mixture (10% EtOH), it was shown that the best operating pressure was between 80 and 100 mm. of mercury, again agreeing well with standard practice (100 mm.). The accompanying figure B illustrates how change in pressure of the filling affects the length and slope of the resultant plateau.

During these experiments, since it was noticed that the starting voltage rose with time and also the plateau slope and length improved for any specific filling, the plateau determinations for the above mixtures were made on filling, to give a valid comparison of one with the other. Examples of this settling down effect can be seen in figure A where the curve for 7% alcohol shows much the/

the best plateau, but was only obtained 24 hours after filling, and in figure B, where the curve for 178 mm. pressure was repeated 24 hours later giving a much improved plateau. (Shown as a broken line.)

c. Calibration.

Before actually using the counter it was necessary to see how the counting rate depended on the pressure of the radioactive gas in the sample holder. Constant geometry from one sample to the other was ensured since the counter window was attached permanently in a fixed position in the gas cell, and for the same reason the scattering effect of the sample holder (made of glass) was also a constant factor. However it was necessary to determine the effect of self-absorption and self back-scattering of the sample on the count rate, since as its pressure is raised, its effective thickness is also raised and hence more self-absorption will occur. The necessary calibration curve was found by plotting the counting rate of different pressures of the same sample against its pressure, and by using the curve to convert counting rates to a standard pressure, valid comparison of the activities of different samples could be made, without involving troublesome pressure adjustments.

COUNTER CALIBRATION CURVES AND SYNTHESIS
AS COUNTING RATE AGAINST DENSITY.

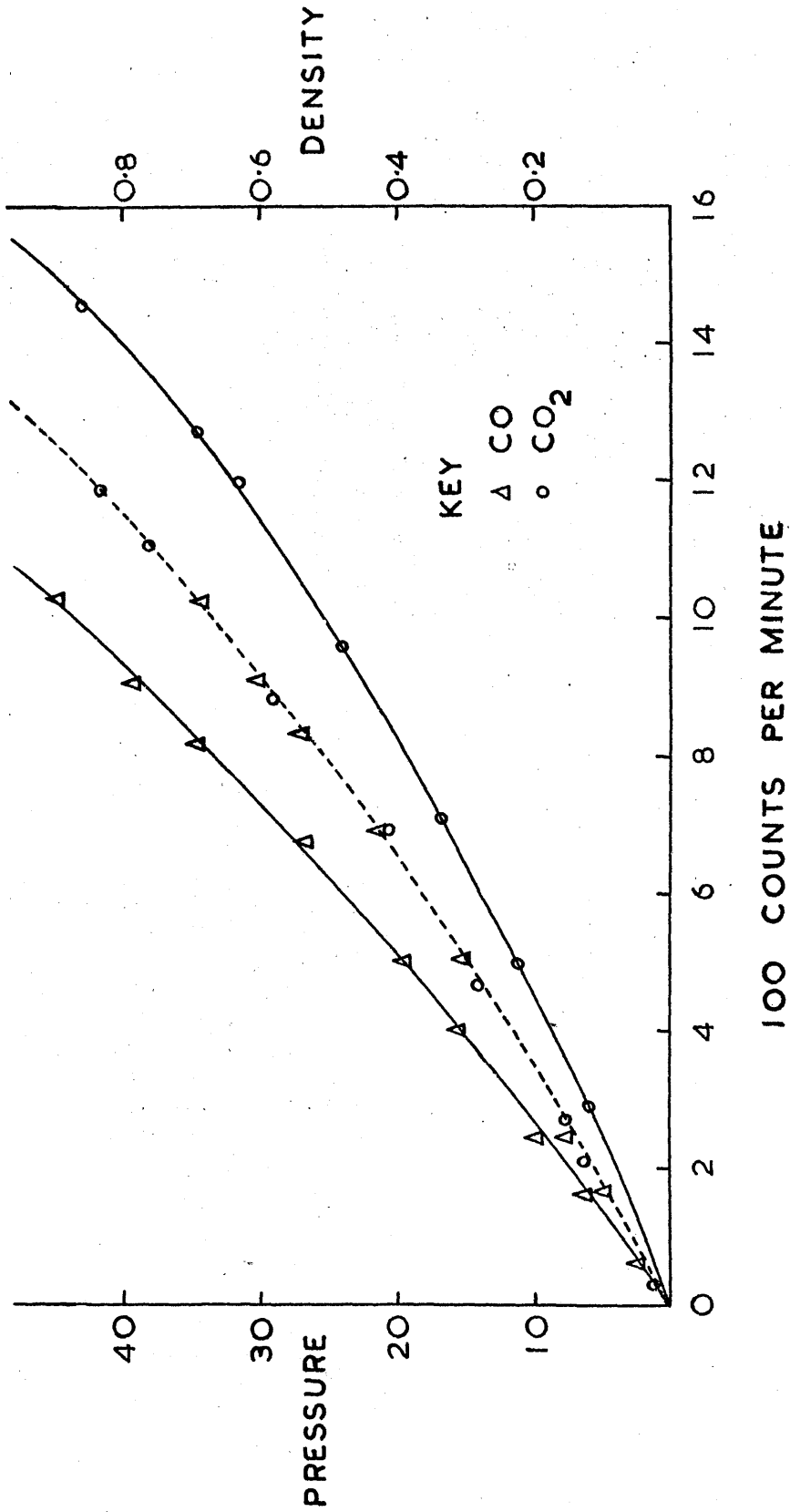

FIGURE 18

Calibration curves for carbon dioxide (from active barium carbonate by the action of concentrated sulphuric acid) and for carbon monoxide (from active sodium formate and concentrated sulphuric acid) are shown in the figure opposite. These curves are not identical since self-absorption is dependent on the density of the material and these two gases have different densities at the same pressure in the holder. For comparison of one gas with the other, it is necessary therefore to plot count rate against density and not pressure. Such a curve is illustrated in figure 18 and as would be expected exactly the same curve is given for carbon dioxide as for carbon monoxide. (Broken line)

The specific activity of the gas can be measured as cts./min. per mg./ml. since the volume of the cell remains constant. If the curves produced above are due entirely to self-absorption, then the plot of the logarithm of specific activity against thickness of the sample (measured as a density here) will be linear since self-absorption is an exponential function of thickness. Such a plot for carbon dioxide is shown in figure 19 overleaf, and where thickness is small, can be seen to be curved showing that scattering is taking place to a noticeable extent. This curve is similar to that found/

LOGARITHM OF SPECIFIC ACTIVITY AGAINST THICKNESS

FIGURE 19

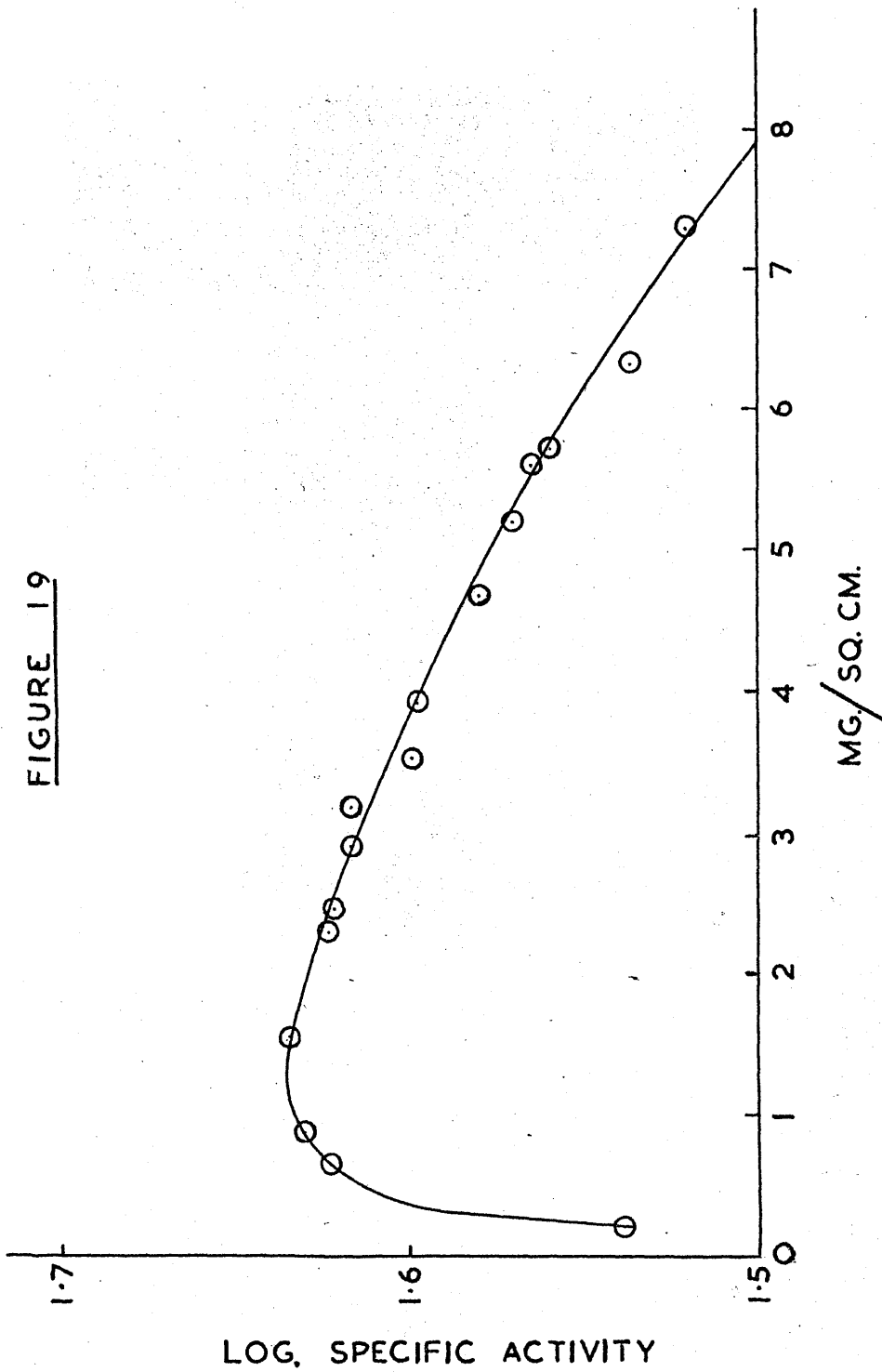

found by Shaw³⁹ for barium phosphate containing P³² and for silver iodide containing I¹²⁸ although the maximum is at a much lower thickness for C¹⁴ than for these heavier compounds, as would be expected for the weaker radiation of C¹⁴.

V.

EXPERIMENTAL DETAILS.

V.1. The apparatus and its manipulation.

a. The circulating apparatus.

This was in effect an assembly of separate glass units joined together by glass tubing to form a cycle around which gas could be continuously circulated.

In order these units were,

- 1) Circulating pump.
- 2) Pump exit ballast bulb.
- 3) Flowmeter.
- 4) Reaction chamber.
- 5) Cold traps.
- 6) Pump entrance ballast bulb.

Various other units were attached to the cycle at convenient points, as shown in the block schematic diagram, page 15.

- 7) High vacuum line.
- 8) Gas reservoir.
- 9) Gasometer.
- 10) Gas purification and synthesis unit
- 11) Heated decomposition tube.

The construction and function of each of these units will be described in turn.

a.1. The circulating pump.

During the earlier preliminary runs the pump used to circulate the gas in the system was an electromagnetic piston pump similar to that described by Porter, Bardwell and Lind⁴⁰, employing a glass piston enclosing a soft iron core. The piston was raised by means of a solenoid and fell under gravity when the current through the solenoid was discontinued. By using a make-and-break device of two brass plates forced into contact at regular intervals of time by a rotating cam driven by an electric motor, the necessary movement was imparted to the piston, and by incorporating two ground glass ball valves making movement of the gas possible in one direction only, flow was produced of up to 12 litres per hour depending on the speed of rotation of the cam.

This pump had several limitations, the major of which was that the solenoid became very hot when in operation and although the heating effect on the gas stream was probably harmless, the risk of fire made it unsafe to leave the apparatus unattended and so imposed a limitation on the length of a cycling run.

An alternative was therefore constructed in the form of a modification of the automatic gas circulating pump of Simons, Brice, and Pearlson⁴¹.

In this pump the piston was mercury in one arm of a U-tube and was recurrently raised and lowered by means of an electrical circuit which alternately applied and released a vacuum on the other limb of the U-tube, the gas being forced to flow by means of one-way mercury valves on either side of the pump. In the present case the pump was simplified in that the necessary motion of the piston was produced by the action of a head of water above the mercury in the non-piston limb of the U-tube, which was varied regularly and continuously between two levels by means of an ordinary siphon arrangement. Water was admitted at a steady rate to the limb and the level rose until it reached the top of the siphon when it fell again until the siphon was broken. By simple adjustments to the rate of admission of water and to the height of the siphon, it was possible to produce almost any desired rate and length of stroke of the mercury piston.

When gases were cycled in the system, the internal pressure normally fell with time. To follow this drop in pressure accurately it was essential to ensure that at each pressure reading the volume of the system was constant, i.e. that at each reading the level of the mercury piston was the same. This was accomplished by placing/

placing a large bore tap (10 mm.) below the piston, which when shut prevented the oscillations in the water head from registering on the mercury, and further by attaching another tap to the bottom of the U-tube through which mercury could be removed when necessary, otherwise as the internal pressure dropped, the mercury in the piston would rise continuously under the atmospheric pressure on the other end of the tube. In this way it was possible to have the mercury piston at the same level for all the pressure readings.

To allow for a large pressure contraction during a cycling run, it was essential to have a correspondingly large distance between the bottom of the U-tube and the mercury piston level. Further, to make maximum use of the short mercury movements, it was necessary to have the cross-sectional area of the mercury levels as large as possible. In practice a compromise was struck between the large dimensions of the pump desirable in this way, and the small dimensions preferable to reduce to a minimum the strain imposed on the glass by the weight of the mercury. The open limb of the U-tube was a glass cylinder 35 mm. in diameter which could be filled with mercury to a maximum height of 400 mm. The diameter of the piston was 90 mm. Although with a movement of 5 mm./

5 mm. of the mercury in the piston per stroke and a maximum of three strokes per minute, the rate of flow realisable was over 8 litres per hour, the pump was usually run at 5 litres per hour, and could be left unattended with the utmost confidence that the rate of flow produced would be maintained constant for a pressure range of 800 mm. to 400mm. within the cycle.

a.2. The exit ballast bulb.

This was a bulb of 3 litre capacity, placed between the pump and the flowmeter, which had the effect of smoothing out the surges in the gas stream produced by the action of the pump. It was possible however to isolate this bulb and pass the gas straight from the pump to the flowmeter, in which case fluctuations of up to 1 cm. were registered on the flowmeter compared with the 1mm. surges produced when the gas passed through the bulb.

a.3. The flowmeter.

The flowmeter was of standard design⁴², the rate of flow of the gas through a capillary tube being proportional to the pressure differential between the ends/

ends of the tube, and this was determined from the difference in the levels of a liquid in a U-tube, one end of which was attached to each end of the capillary.

The liquid used in this case was dibutyl phthallate, which has a suitably low vapour pressure. During the cycling experiments, this flowmeter was used merely as a guide as to whether flow was or was not taking place, since there were too many difficulties attached to using it as a quantitative guide. (The calculation of the relationship between the rate of flow and the difference in levels in the limbs is not at all easy for a mixture of gases in constantly varying proportions and varying pressures.) If required it was considered more reliable to use the rate of stroke of the circulating pump as a measure of the rate of flow. The flowmeter was useful when taking a pressure reading since it gave a reliable guide as to whether the pressure gradient in the apparatus had evened out and it was safe to take a pressure reading.

a.4. The reaction chamber.

This was the central tube of a Bl9 water condenser which had been modified, the cone end having been replaced by a length of glass tubing bent in a U shape with a ground glass joint at its end so that the unit could/

could be detached for filling simply by pulling apart the two sets of joints simultaneously. When attached the tube was in a vertical position.

The leads of the outer jacket of the condenser were also replaced by Quickfit joints in such a way that a distillation flask could be fitted on to the lower and a condenser on to the other and by boiling a liquid in the flask and condensing it in the condenser, the inner tube of the modified condenser could be maintained at a constant temperature - the boiling point of the liquid in question.

This constant temperature zone was the reaction chamber of the cycling apparatus, and the solid was held within its limits by means of glass wool plugs. That the reaction bed was at the expected temperature was confirmed by reading the temperature on a thermometer which penetrated through the top glass wool plug so that its bulb was immersed in the solid.

When in use the gas stream entered from the lower end of the vessel, passed through a preheating zone of about two inches of glass wool plug, then over the solid and out at the top of the tube.

For filling, the U-tube was detached by melting the sealing wax and pulling the joints apart so that the whole unit was separated from the cycle. The lower/

lower glass wool plug was placed in position, the vessel was inverted over an open weighed tube containing the solid to be used and on restoring to its normal position the solid was transferred to the reaction chamber. The weighed tube was then tapped to remove any loose particles, withdrawn from the reaction tube and reweighed to give by difference in weights the amount of solid in the tube. The upper glass wool plug and the thermometer (300 or 550° C. when necessary) were then put in place and the reaction tube was attached to the system once more with vacuum tight joints sealed with Picein.

As stated above the temperature of the reaction chamber was controlled by the boiling point of the liquid in the round bottom flask attached to the outer jacket of the reaction vessel. This bulb was readily detachable because of its ground glass joint connection and hence the liquid and therefore the reaction temperature could be altered at will. The liquid was boiled by means of an electrically heated mantle. The following is a list of the liquids used and the resultant temperatures.

Petroleum ether	28° C.
Diethyl ether	35° C.
Allyl chloride	48° C.
Acetone	56° C.

Methyl alcohol	65°C.
Benzene	80°C.
Water	100°C.
Bromobenzene	156°C.
Aniline	185°C.
Impure aniline	190°C.

- - - - -

In the preparation of a Fischer-Tropsch catalyst it was necessary to maintain the reactor at 440°C. for several hours. This was not possible using the above method and it was necessary to wind a length (ca. 4 yards) of nichrome tape on asbestos paper around the outer jacket of the reaction vessel and to heat the system electrically using a SUNVIC control to maintain the desired temperature.

a.5. The cold traps.

These were three in number and all were of standard form⁴⁸, the gas entering through a side arm and leaving via a centre tube which penetrated to within one inch of the bottom of the trap. Each trap had a volume of about 130 ml. and they were joined directly in series.

During cycling runs they were immersed in liquid oxygen and before making a pressure reading, it was the/

the invariable practice to fill up the Dewars with this refrigerant to a point one inch below the entrance of the side arm.

The traps were efficient enough to remove all vapours from the cycling gas stream except carbon monoxide, argon, hydrogen, and some methane. This made it an easy matter to separate reactants and reaction products except for the case of methane in a Fischer-Tropsch reaction, which required special treatment.

a.6. The entrance ballast bulb.

This 2 litre glass bulb served a similar function to the exit ballast bulb, i.e. pulses in the gas stream were smoothed out.

a.7. The high vacuum line.

This was a standard vacuum line having two mercury pumps in series backed by a rotary oil pump. Since this line was often used to evacuate the cycle when it was full of carbon monoxide, the oil pump was housed in a fume cupboard to prevent the poisonous gas entering the laboratory atmosphere.

a.8. The gas reservoir.

This reservoir consisted of four 5 litre bulbs joined together by a glass neckpiece and equipped with a manometer. It was attached not only to the cycle, but also to the gas synthesis line and the high vacuum line so that it could be evacuated and then filled with any desired gas or gases to any desired pressure (read on the manometer). The principal use of the reservoir was to prepare mixtures of gases in known proportions for admission to the cycle. For this purpose it was also found essential to attach a Topley pump to the bulbs so that the combination of gases within the bulbs could be thoroughly stirred to produce the necessary homogeneity in the mixture, since natural diffusion was not rapid enough to accomplish this in a short time.

a.9. The gasometer.

This was a 10 litre glass jar fitted with a rubber stopper through which two short leads and one long lead of glass tubing were passed. Each of the two short leads was provided with a tap a short distance above the stopper and penetrated just through the stopper and no more. The longest lead passed almost to the bottom of the gasometer.

The first short lead led through connecting tubing to the gas synthesis unit and also to the cycle, so that gas could either be fed from the synthesis unit into the gasometer or led from the gasometer into the cycle.

The second short lead was to a supply of water maintained at a constant height no matter how much water was allowed to flow into the gasometer. This was accomplished by means of a "constant head" device consisting of a glass tube (24 mm. diameter) with an overflow sidearm attached 5 cms. above the attachment to the gasometer. Water was admitted at such a rate to this tube that, no matter the rate at which it was allowed to flow into the gasometer there was always some overflowing through the side arm. The third and longer lead was an outlet for the expulsion of water from the gasometer when it was being filled. So that the water could be collected and measured, this tube was bent over at the top.

The gasometer was filled with water and the tap to the water supply was closed. Gas A was then admitted from the synthesis line, expelling water which was collected and gave a measure of the volume of A in the gasometer at the pressure P, where P is equal to the atmospheric pressure less the saturated water vapour for the temperature of the water, but plus the pressure equivalent to the head of water in the expulsion tube (i.e. the distance in/

in cms. between the top of the outlet tube and the water level in the gasometer, divided by 13.6 to convert to cms. of mercury). The entrance tap was shut and the preparation line was evacuated and then filled with gas B. When at a sufficiently high pressure, B was similarly allowed to enter the gasometer, displacing water. From the volume and pressure of each gas the composition of the mixture was known.

The function of the gasometer was to provide a constant flow of gas or gas mixture over the solid in the reaction chamber of the cycle. By opening the tap to the constant head device, water was allowed to flow into the gasometer expelling the gas at a constant rate, which was led over hot copper (200°C.) to remove any contaminating oxygen from the water, through two large liquid oxygen traps to remove any carbon dioxide and water vapour, then over the flowmeter and into the reaction chamber. The consistency of flow of the gas provided in this manner was very satisfactory, the flowmeter giving an unwavering reading throughout the run. Since the attachment from the constant head to the gasometer was of rubber tubing for part of its length, it was possible to alter the height of the head and therefore to alter the rate of flow from run to run.

a.10. The gas synthesis and purification line.

The gases required for use in the cycle were prepared as outlined in the section V.2., and were each admitted to the purification line through a separate vacuum tap. In the cases of hydrogen, argon, and carbon monoxide where it was sometimes desirable to measure the rate of flow, a flowmeter was placed between the cylinder and the tap.

Purification consisted of passage over copper at 200°C. to remove any traces of oxygen which would otherwise poison the nickel, then through two large liquid oxygen traps to remove other contaminants such as water vapour. (In the case of methane these traps were immersed in acetone/solid carbon dioxide, since liquid oxygen would condense this gas.) Carbon monoxide was given the treatment of a scrubbing in concentrated sodium hydroxide solution (in two 3 ft. high tubes packed with glass beads) before passing into the cold traps. The gases were admitted either into the cycle or into the reservoir on leaving the second cold trap.

An attachment to the vacuum line made it possible to evacuate both the purification and the synthesis lines at any time.

a.11. The decomposition tube.

This was a Pyrex tube attached by a ground glass joint and a vacuum tap to the exit end of the reaction chamber. The tube was 24mm. diameter, 30 cms. long, and was tapered at the exit end to allow attachment of a rubber tube which led to a fine glass jet under water through which effluent gas was bubbled and collected. A tubular furnace heated the tube to about 500°C. and as a result, any nickel carbonyl passing down the tube was decomposed before it reached the exit, and either deposited a nickel mirror on the walls or was filtered from the gas stream by a glass wool plug at the exit of the hot tube.

a.12. Use of the cycle.

As long as the circulation velocity is much greater than the reaction velocity, then there is no doubt that true reaction velocities are measured in the quasidynamic arrangement which this cycle constitutes.⁴⁴ The reaction velocity in the reactions studied with this apparatus was conveniently measured by the rate of loss of pressure within the apparatus. It was invariably found that the rate of reaction was very much less than the rate of flow within the system.

The measurement of pressure involved the following operations.

- (1) The Dewar vessels around the cold traps were filled up to the standard level.
- (2) The circulating pump was stopped with the piston at the mark.
- (3) The tap to the manometer was opened.
- (4) The temperature of the system was read to the nearest 0.10° , by means of a thermometer hanging in the middle of the apparatus.
- (5) When the flowmeter showed that flow had stopped the tap to the manometer was closed.
- (7) The tap on the pump was then opened and the gas circulation resumed.
- (8) The pressure reading was noted to the nearest 0.05 mm. using a cathetometer.

Apart from the actual reading of pressure, the above process was completed in about 30 seconds.

During a run such readings were taken at noted times (generally every 30 minutes), and the pressures were all corrected for temperature variations by converting to 20.0°C . before comparison was made.

b. Apparatus for studying the thermal decomposition of nickel carbonyl.

This apparatus was designed for flow type experiments and had the following units in series.

- (1) Cylinder of carrier gas (nitrogen oxygen-free).
- (2) Flowmeter of standard design.⁴²
- (3) Tube containing Phosphorus pentoxide to dry the gas stream.
- (4) Bubbler containing nickel carbonyl liquid.
- (5) Cooled traps ($-20^{\circ}\text{C}.$).
- (6) Reaction vessel.
- (7) Heated decomposition tube.
- (8) Gas collection vessel.

Units (1) to (5) were attached to the high vacuum line. There was a by-pass between (3) and (6) so that the reaction vessel could be flushed out with carrier gas before use. (This operation was generally half an hour in duration.) There was an outlet placed just before the entrance tap of the reaction vessel so that a steady stream of nickel carbonyl carrying gas could be set flowing and then diverted at a noted time into the reaction vessel.

Because of the dangers of explosion and of leakage of the highly toxic nickel carbonyl vapour, this apparatus was constructed within a fume cupboard.

The nickel carbonyl bubbler consisted of a glass U-tube with one thin limb and one broad limb which was packed with glass beads. The nickel carbonyl was distilled into this carburettor through a vacuum tap at the top of the broad limb, and was freed from dissolved carbon monoxide by alternately freezing and liquefying six times, opening the vessel to the pumps when the carbonyl was frozen. During a run, carrier gas was admitted through the narrow limb, bubbled through the liquid and left the vessel saturated with nickel carbonyl vapour.

This stream of gas was next passed through four cooled traps connected in series and all immersed in a slush bath at -20°C . (technical grade tetrachloroethylene), where the carbonyl vapour pressure was reduced to a known constant value. These traps were of standard design but were filled with small pieces of glass to give a much larger cold surface for condensation. By altering the temperature of the traps it was possible to change the carbonyl content of the gas stream, although in practice it proved impossible to reduce it below -25°C . without choking the traps with solid nickel carbonyl.

The results shown overleaf are satisfactory since it is apparent that the amount of nickel carbonyl entering the reaction vessel is the same from run to run.

Table V.1. Consistency of nickel carbonyl vapour pressure from run to run.

Run number	1	2	3	4	5
mg.Ni/ml.gas	0.123	0.126	0.124	0.124	0.124
Run number	6	7	8	9	10
mg.Ni/ml.gas	0.123	0.125	0.123	0.124	0.126

The reaction vessel was the spiral of a B19 spiral condenser, which was modified for this purpose by having ground glass joints fitted to the leads to the spiral. These joints allowed the vessel to be readily detached from the system. The spiral was kept at constant temperature by filling the surrounding jacket with the vapour of a liquid which was boiling in a flask attached to the bottom of the modified condenser, and which was condensing in a condenser attached above. The temperature was readily altered by changing the liquid in the boiler, and the temperature was read on a thermometer hanging with its bulb at the centre of the spiral.

The effluent gas from the reaction chamber passed down a heated decomposition tube identical with that described on page 122, where the residual carbonyl was decomposed.

By timing the collection of a known quantity of gas effluent from the decomposition tube, noting the duration of the run, and determining the amount of nickel deposited in the reaction tube and also in the decomposition tube, it was possible to calculate the number of carbonyl molecules entering and leaving the reaction tube per second. From the volume of the spiral and the rate of flow of gas through it, the average time each of these molecules spent within the reaction zone could be found. If a known but variable quantity of carbon monoxide were continuously introduced into the carrier gas, and the total flow rate varied from run to run, then determination of the corresponding variations in the above calculated quantities would make possible the derivation of the kinetics of decomposition of nickel carbonyl.

As stated earlier the results were very disappointing since there was no consistency in the results of experiments made under identical conditions, and therefore no reliance could be placed on the results of runs made under varying conditions.

c.1. Apparatus used for C¹⁴ tracer work.

This was a simple vacuum manifold with the following/

following units attached:-

- (1) Manometer.
- (2) Gas counter tube.
- (3) Gas counter cell.
- (4) Detachable reservoir bulbs (500 ml.) for -
 - a. Argon/ethyl alcohol mixture for counter.
 - b. C^{14} active carbon monoxide.
 - c. C^{14} active carbon dioxide.
- (5) C^{14} gas synthesis unit.
- (6) Reservoirs for liquid
 - a. Ethyl alcohol.
 - b. Nickel carbonyl.
 - c. Carbon disulphide. (A temporary fixture.)
- (7) Topley pump.

The only unusual feature of this apparatus was the Topley pump which was equipped with vacuum taps instead of the normal metal ball valves. The pump was used to transfer gas from the manifold or any of the attached units into the reaction vessel which was attached to the "outlet" end by a quickfit joint. By driving (if necessary with the aid of the pressure from a gas cylinder) the mercury right up this connection to the vacuum tap entrance of the reaction vessel, which was then closed, it was/

was possible to ensure complete transfer of gas from, say the gas sample cell, to the reaction bulb.

The pump could also be used to transfer gas from the reaction vessel to the main line dead space, which was used alone, or in conjunction with the sample cell, as a calibrated volume for measuring (with the manometer) quantities of gas.

The reservoir bulbs could be removed from, and reattached to the vacuum line by means of ground glass joints.

c.2. C¹⁴-containing gas assay.

The assay of a gas sample consisted of the following steps -

- (1) The sample was pumped from the reaction bulb into the manifold and the gas counter cell.
- (2) The pressure and temperature were noted.
- (3) The sample holder was closed and the count was made.
- (4) The sample was then completely pumped back into the reaction vessel, i.e. until the pressure in the manifold became zero.

Used in this way the counter gave no noticeable "memory" effect, although if a highly active sample was/

was left in contact with the counter window for a long time (24 hours), the background count of the tube rose noticeably (from 65 per minute to 80 or more). This is believed to be caused by diffusion of active gas through the MELANEX (known to be slightly permeable to gases). The background was reduced to normal by evacuating the tube to a low vacuum and then refilling from the reservoir bulb of argon/ethyl alcohol mixture.

V. 2. Preparation and purification of materials.

a. Carbon monoxide.

This was prepared by the action of concentrated sulphuric acid on formic acid.⁴⁵ The reaction vessel was a 2 litre three-necked flask with two dropping funnels attached for adding the reactants, and a mercury bubbler safety valve. Air was removed from the apparatus through an attachment to the vacuum line, and then the reactants were allowed to enter. The carbon monoxide evolution was brisk at first but eventually had to be promoted by heating. Because of the large capacity of the vessel it was possible to generate up to 300 litres of carbon monoxide before the flask required removal for emptying.

The gas was purified by passage over copper at 200°C., through concentrated sodium hydroxide solution, and then two liquid air traps. The first few litres were discarded as a further precaution against contamination.

b. Argon.

This gas was supplied in a cylinder by British Oxygen Gases, Ltd., and before use it was passed over the hot copper to remove any oxygen, and then through two liquid oxygen cooled traps.

c. Hydrogen.

Also supplied in a cylinder by British Oxygen Gases, Ltd., this gas was purified in an identical manner to the argon.

d. Nitrogen.

This gas was supplied free from oxygen by British Oxygen Gases, Ltd., and was dried before use by passage through a tube packed with phosphorus pentoxide. Since the results using this gas were poor, for later runs it was also passed over hot copper to remove any oxygen traces.

e. Nickel formate.

The nickel formate supplied by British Drug Houses/

Houses, Ltd., was found to be impregnated with ammonium salts which poisoned the nickel produced from the formate for carbonyl synthesis. The material was therefore prepared from AnalaR reagents as described by Csuros, Geczy, and Szabo.⁴⁶

Sodium carbonate (110 g.) dissolved in a little distilled water, was slowly added to a boiling solution of nickel sulphate (250 g.) in distilled water (500 g.). The precipitate was washed with distilled water until neutral, dissolved in 98% formic acid (100 g.), boiled and filtered, giving rise to green crystalline nickel formate (161 g.) when dried at 100°C.

f. Nickel carbonyl.

Although the experiments on the kinetics of the synthesis of nickel carbonyl gave rise to this compound, the yields were insufficient for the needs of the decomposition experiments, and were therefore supplemented by making the carbonyl as described in Inorganic Syntheses.⁴⁷

Carbon monoxide was passed at 60°C. over active nickel produced by the decomposition of nickel formate in a stream of hydrogen at 180°C., and the effluent gas was cooled in a trap immersed in liquid oxygen and then passed into the air vent of a Bunsen burner. The carbon monoxide supply/

supply line was equipped with a mercury bubbler safety valve in case the condensation of the carbonyl choked the cold trap.

The carbonyl was purified by distillation over phosphorus pentoxide, and two further vacuum distillations from -20°C . to -180°C . Finally it was freed from any dissolved carbon monoxide by alternately freezing and liquefying, pumping off any gas left when the carbonyl was frozen.

g. Nickel Fischer-Tropsch catalyst.

This was prepared as described by Aicher, Myddleton, and Walker.⁴⁸

Nickel nitrate (1000 g.), manganese nitrate (200 g.), and aluminium nitrate (136 g.) were dissolved in distilled water (2 litres), kieselguhr (240 g.) was added, and a solution of potassium carbonate (880 g. in 2 litres) was stirred in. The mixture was boiled for 15 minutes then the precipitate was filtered and washed with hot distilled water (30 litres). The solid was dried and the final step of the synthesis, the reduction with hydrogen at 450°C . for several hours, was carried out with the solid in the reaction chamber of the cycling apparatus.

h. Standard nickel solution.

For the colorimetric estimation of nickel solutions it was necessary to have standard nickel solutions with which the unknown solutions could be compared. A standard solution was prepared by dissolving a piece of 99.9% pure nickel wire (20, 30, or 40 mg.) supplied by Johnson-Matthey Ltd., in 50% nitric acid and making the solution up to 1 litre with distilled water.

i. Homogeneous C¹⁴ active barium carbonate.

Solid C¹⁴ barium carbonate was placed at the bottom of a three-necked 3 litre flask which was then swept free from atmospheric carbon dioxide with a stream of nitrogen previously passed over soda-asbestos. The gas entrance and exit taps were then closed, and concentrated sulphuric acid admitted to the vessel from a dropper in the third neck. The barium carbonate dissolved as sulphate evolving carbon dioxide gas, and since all the C¹⁴ was present in the gas phase at the same time, the material soon became homogeneous by diffusion. The flask was allowed to stand for an hour and the nitrogen flow was then resumed, but this time the effluent gas was passed through four bubblers in series containing a solution of barium hydroxide, where the carbon dioxide was converted to barium carbonate as it was swept from the flask.

These barium hydroxide solution bubblers were centrifuge tubes (50 ml.) fitted with rubber stoppers through each of which passed two leads of glass tubing (2 mm. bore), one almost to the bottom of the tube, the other just through the stopper and no more. The tube was flushed with nitrogen (free from carbon dioxide), and the baryta was filtered into it by connecting the longer glass lead to the filter funnel. The four tubes were connected to each other and to the carbon dioxide generator by short lengths of rubber tubing. When all the carbonate had been precipitated, the tubes were centrifuged with the stoppers still on. The stoppers were removed, the solution poured off quickly and the tube washed with hot water (boiled). The precipitate was washed several times with this water, twice with ethyl alcohol and finally with ether after which it was collected and kept in a vacuum desiccator until required.

j. Radioactive carbon monoxide.

A solution of C^{14} radioactive sodium formate was evaporated to dryness in a 50 ml. flask, which was then fitted with a dropping funnel containing concentrated sulphuric acid and attached through a small cold trap to the vacuum line. The carbon monoxide reservoir was/

was connected to the Topley pump and the entire apparatus was evacuated. The acid was admitted, producing carbon monoxide which passed through a small trap cooled in liquid oxygen to remove acid spray and any carbon dioxide, as it was pumped into the reservoir bulb. The bulb was then closed, detached and reconnected to the vacuum line in its normal position.

k. Radioactive carbon dioxide.

This was made by the analogous reaction between concentrated sulphuric acid and solid barium carbonate containing C^{14} using an identical set of operations to the above, except that the liquid oxygen bath was replaced by an acetone/solid carbon dioxide slush bath.

l. Methane.

Made by heating a mixture of sodium acetate and soda lime in a tube attached to the gas synthesis line, the methane was purified by passage over copper at $200^{\circ}C$. and then through two traps immersed in an acetone /solid carbon dioxide cooling mixture.

m. Solution of ammoniacal cuprous chloride.

This solution was used to effect the separation of methane and carbon monoxide since it dissolves the latter/

latter readily but does not affect methane.⁴⁹ On adding the solution to a mixture of these two gases the carbon monoxide dissolved, and the methane could be pumped off into a separate vessel if the solution were first frozen.

The carbon monoxide could be regenerated by adding concentrated sulphuric acid to the solution⁴⁹, and passing the product gas through a liquid oxygen trap to remove any carbon dioxide formed at the same time from ammonium carbonate in the solution.

Preparation.

Ammonia gas from a cylinder was bubbled through concentrated ammonia solution for ten minutes or so to remove any dissolved permanent gases. Excess cuprous chloride was added followed by an equal volume of freshly boiled distilled water, and the vessel was stoppered. This gave a solution free from oxygen and nitrogen and effective in the absorption of carbon monoxide.

V. 3. The estimation of the nickel deposited by the thermal decomposition of nickel carbonyl.

The nickel deposit was dissolved in hot 50% nitric acid and the solution made up to a known volume in a standard flask. Some of this solution was then estimated colorimetrically using the red nickel dimethylglyoxime complex in ammoniacal solution in the presence of an oxidising agent, and a Unicam spectrophotometer.

The details of the method are as follows ⁵⁰ -

5 ml. of the unknown solution were pipetted into a 50 ml. graduated flask, and 15 ml. of water were added. Freshly prepared saturated bromine water was added dropwise until the solution was distinctly yellow and then 2 drops in excess. 10 ml. of concentrated ammonia were introduced followed by 2 ml. of a 1% solution of the sodium salt of dimethylglyoxime in water. The solution was then made up to the mark with water and the flask shaken well.

After standing for 30 minutes the optical density of the solution was measured at $4,450 \overset{\circ}{\text{Å}}$ in a 10 mm. glass cell with an SP. 500 Unicam spectrophotometer. By comparison with the optical densities of two different standard nickel solutions determined simultaneously with the unknown, the amount of nickel in 5 ml. of the unknown solution could be calculated, and hence the amount of nickel in the original deposit could be found.

V. 4. Experimental results.

The more important results are embodied in the text as either diagrams or tables. This section contains results which it was not considered essential to give earlier.

a. Nickel carbonyl decomposition runs - (page 60).

Some specimen results are given below. As can be seen from the last column, the reproducibility from run to run was poor.

Run	Time of run in seconds	Flow rate l/hr.	Spiral temp. °C.	Wt. of Ni deposit in spiral	Total Ni deposit	%age decomp.
D ₁	1800	4.50	65	4.8	281	1.7
D ₂	1800	4.38	65	4.3	276	1.5
D ₃	1800	4.42	65	2.9	276	1.0
D ₄	1800	4.56	65	3.4	287	1.2
D ₅	1800	4.39	65	1.2	277	0.4
D ₆	1800	4.50	65	4.5	280	1.6
D ₇	1800	4.44	65	3.9	276	1.4
D ₈	1800	4.47	65	2.3	278	0.8

b. C¹⁴ exchange experiments.

b.1. Carbon monoxide and methane. - (page 73).

Original count rate of carbon monoxide corrected to 20 cms. pressure was 507 counts per minute and the final rate was 511 counts per minute. Therefore no exchange had taken place.

b.2. Nickel carbonyl and methane - (page 74).

After 5 hours of cycling, the count rate of a sample of methane at 13.7 cms. pressure was 67.2 ± 0.7 counts per minute. On comparing with the natural background count of 65.7 ± 0.7 per minute, it was apparent that there had been no exchange.

b.3. Carbon monoxide and nickel carbonyl.

Temperature in °C.	35	57	57	57	57
Time in minutes	720	720	60	6	6+4
Original P _{CO} (mm.)	207	246	272	280	280
Final P _{CO} (mm.)	207	247	274	281	281
Pressure of Ni(CO) ₄	46	51	37	43	43
Original count rate (carbon monoxide)	510	513	511	510	510
Final count rate	463	287	341	400	346
% of possible exchange	20	100	99	57	85

c. Estimation of C¹⁴ content of barium carbonate by counting from solid. - (pages 89-90).

c.1. Suspensions.

The average of 50 different estimations at infinite thickness was 492.6 counts per minute. The following table gives an example of how the count varied from sample to sample, and the percentage deviation from the mean.

Sample	Cts/min.	Deviation	Sample	Cts/m.	Deviation
1	481.6	2.2	6	471.0	4.4
2	473.9	3.8	7	501.1	1.8
3	510.2	3.6	8	487.6	1.0
4	478.6	2.8	9	493.1	0.1
5	526.0	6.8	10	474.4	3.7
11	502.7	2.0	12	499.9	1.5

c.2. Pastes.

Sample	Cts/min.	Deviation	Sample	Cts/m.	Deviation.
1	483.1	1.9	5	493.2	0.1
2	475.6	3.4	6	487.6	1.0
3	511.1	3.8	7	501.1	1.7
4	508.9	3.3	8	497.6	1.0

c.3. Filtering.

Sample	Cts./min.	% deviation.
1	482.7	2.0
2	477.2	3.1
3	501.6	1.8
4	493.0	0.8
5	506.9	2.9

after pressing with hot steel rod -

6	487.6	1.0
7	493.1	0.1
8	489.6	0.6
9	502.1	1.9
10	485.5	1.4

Appendix.

An APEX hydraulic press, Type A1, capable of applying 10 tons/sq.inch, was used to supply the pressure for making pellets for counting.

The die used with the above press was supplied by the Research and Industrial Instruments Company, and is normally used to prepare discs of potassium chloride or bromide for infra-red spectroscopy.

The count was made with an EKCO scalar type N 529B.

The end-window gas counter was constructed in a similar manner to the counter shown in the diagram facing page 82, except that the lower end of the glass jacket was not sealed off, but was flanged outwards and sealed to a window. The central anode wire was ended in a glass bead to prevent spurious discharges, just above the foot of the copper cathode, and was left supported by the top glass/tungsten seal only.

The window was of MELANEX (less than 2 mg./sq. cm. in thickness) sealed to a brass ring of the same dimensions as the glass flange and supported by five nickel wires soldered to the ring, which was sealed with Picein to the/

to the flange of the counting tube on the one side, and to the flange of the gas sample cell on the other.

Before fitting the copper cathode it was treated as follows -

- (1) Immersed in solution A at 80°C. for 8 minutes.
- (2) Removed and immersed immediately in solution B for no more than two minutes then washed thoroughly in water.
- (3) Dipped in solution C for a few seconds, washed immediately and thoroughly, rinsed in alcohol and allowed to dry.

Solution A.

Ammonium chloride (300 g.), concentrated hydrochloric acid (90 ml.), and gelatin (50 ml. of a solution 0.2% by vinegar), made up to 1 litre with water.

Solution B.

Chromic acid (250 g.), concentrated sulphuric acid (75 ml.), solution A (35 ml.), and gelatin (50 ml.), made up to 1 litre with water.

Solution C.

Chromic acid (250 g.), concentrated sulphuric acid (75 ml.), made up to 1 litre with water.

Bibliography.

1. Sabatier and Senderens, 1902, Compt. Rend., 134, 514.
2. Fischer and Tropsch, Ber., 1926, 59, 830, 832, 923.
3. Fischer and Tropsch, Brennstoff-Chem, 1926, 7, 97-104.
4. Fischer and Koch, Brennstoff-Chem, 1932, 13, 428.
5. Fischer and Bahr, Ges. Abhandl. Kenntnis Kohle,
1928, 8, 269.
6. Fischer and Koch, Brennstoff-Chem., 13, 68, (1932).
7. Storch, Advances in Catalysis, 1948, 1, 150
Academic Press Inc., New York.
8. Craxford and Rideal, J.Chem.Soc., 1939, 1604.
9. Elvins and Nash, Nature, 1926, 118, 154.
10. Eischens, J. Am. Chem. Soc., 1952, 74, 6167.
J. Chem. Phys., 1951, 19, 377.
11. Eidus, Bull. Acad. sci. U.R.S.S. Classe. sci. chim.
1942, 190; 1944, 255.
12. Anderson, Hall, Kreig and Seligman, J. Am. Chem.
Soc., 1949, 71, 183-8.
13. Weller, Hofer, and Anderson, J. Am. Chem. Soc.,
1948, 70, 799.
14. Kummer, Browning, and Emmett, J. Chem. Phys., 1948,
16, 739.
15. Kummer, DeWitt, and Emmett, J. Am. Chem. Soc., 1948,
70, 3632.

16. Kummer, Podgurski, Spencer, and Emmett, J. Am. Chem. Soc., 1951, 73, 564-9.
17. Kummer and Emmett, J. Am. Chem. Soc., 1953, 75, 5177.
18. Kagan, Kryukov, Kamzolkina, Bashkirov, Izvest. Akad. Nauk. S.S.S.R., Otdel Khim. Nauk. 1952, 649.
19. Kokes, Hall, and Emmett, J. Am. Chem. Soc., 79, (1957), 2983-2996.
20. Anderson, Friedel, and Storch, J. Chem. Phys., 1951, 19, 313-19.
21. Pichler, Advances in Catalysis, 4, 336, Academic Press Inc., New York, 1952.
22. Wender and Sternberg, Advances in Catalysis, 9, 594, Academic Press Inc., New York, 1957.
23. Mittasch, Z. physik. Chem., 1902, 40, 1-83.
24. Bibliography on Nickel Carbonyl, Mond Nickel Company Ltd., 1955.
25. Bawn, Trans. Faraday Soc., 1953, 31, 440.
26. Tonosaki, and Suginuma, Bull. Inst. Phys. Chem. Research (Tokyo), 1943, 22, 1014-25.
27. Montgomery and Tomlinson, Catalysis, 4, Reinhold Publishing Corp., 1956.
28. Fischer and Pichler, Ber., 1939, 72B, 327-30.
29. Fischer, Pichler, and Lohmer, Brennstoff-Chem., 1939, 20, 247-50.

30. Fischer, Brennstoff-Chem., 1943, 39, 517-22.
31. Benton, J. Am. Chem. Soc., 1931, 53, 2984.
32. Garratt and Thompson, J. Chem. Soc., 1934, 1822-5.
33. Brown and Millar, Rev. Sci. Instr., 1947, 18, 496.
34. Glascock, Isotopic Gas Analysis for Biochemists,
Academic Press Inc., New York, 1954.
35. International Critical Tables, 6, McGraw-Hill Book
Company, 1929.
36. Kamen, Radioactive Tracers in Biology, Academic Press
Inc., New York, 1947.
37. Adams and Clark, J. Amer. Chem. Soc., 1951, 73, 4609.
38. Anderson, Dilabarre and Bothner-By, Anal. Chem., 1952,
24, 1298.
39. Cook and Duncan, Modern Radiochemical Practice, 237,
Oxford University Press, 1952.
40. Porter, Bardwell and Lind, Ind. Eng. Chem., 1926, 18,
1086.
41. Simons, Brice and Pearlson, Anal. Chem., 17, 404.
42. Dodd and Robinson, Experimental Inorganic Chemistry,
132, Elsevier, 1954.
43. Dodd and Robinson, Experimental Inorganic Chemistry,
134, Elsevier, 1954.
44. Schwab, Advances in Catalysis, 2, 252, Academic Press
Inc., New York, 1950.

45. Inorganic Syntheses, 2, 81, McGraw-Hill Book Company,
1946.
46. Csuros, Geczy, and Szabo, Acta Chim. Acad. Sci. Hung.,
1952, 2, 33-56.
47. Inorganic Syntheses, 2, 234, McGraw-Hill Book Company,
1946.
48. Aicher, Myddleton, and Walker, J. Chem. Ind., 1935,
54, 314T.
49. Sidgwick, The Chemical Elements and their Compounds,
1, 131-2, Oxford University Press, 1952.
50. Method Sheet No. 7, Unicam Instruments Ltd., 1956.
-