

T H E S I S

'SOME ASPECTS OF PHOSPHORUS(V) HALIDES'

This Thesis is presented to the
University of Glasgow for the
Degree of Doctor of Philosophy

by

Gordon Scott Harris, B.Sc.(Glas.).

April, 1956.

The University,
Glasgow.

ProQuest Number: 13848933

All rights reserved

INFORMATION TO ALL USERS

The quality of this reproduction is dependent upon the quality of the copy submitted.

In the unlikely event that the author did not send a complete manuscript and there are missing pages, these will be noted. Also, if material had to be removed, a note will indicate the deletion.



ProQuest 13848933

Published by ProQuest LLC (2019). Copyright of the Dissertation is held by the Author.

All rights reserved.

This work is protected against unauthorized copying under Title 17, United States Code
Microform Edition © ProQuest LLC.

ProQuest LLC.
789 East Eisenhower Parkway
P.O. Box 1346
Ann Arbor, MI 48106 – 1346

The author thanks Dr. D.S. Payne for the help and encouragement received during the work leading to the presentation of this thesis. In addition thanks are due to several members of the academic and technical staffs of the Institute of Chemistry of Glasgow University for numerous useful discussions.

Financial assistance from the Department of Scientific and Industrial Research is gratefully acknowledged.

F O R E W O R D

The phosphorus(V) halides described in this thesis, have, in common with most other non-metallic halides, the property of undergoing hydrolytic decomposition with considerable ease. Therefore in undertaking a study of the physical properties of these compounds, it was essential that the presence of water, and other hydroxylic compounds was excluded. The tendency of the phosphorus(V) halides to act as halogenating agents is another feature which calls for particular attention. Consequently the use of apparatus incorporating rubber parts and tap grease was undesirable. In addition the choice of solvents was severely limited to non-reactive compounds like carbon tetrachloride, nitrobenzene, and acetonitrile ; and when these were used, steps had to be taken to ensure that they were of very high purity and thoroughly dry.

These factors have undoubtedly been responsible for the considerable lack of reliable data on the phosphorus(V) halides ; and their rather unpleasant physical characteristics have in addition been the

origin of the general neglect of this group of compounds.

One of the chief aims of the present work was to develop methods of studying the phosphorus halides in such a way that decomposition would be prevented or at least minimised. Therefore special forms of apparatus were designed and improved techniques evolved. These latter include dry-box and vacuum techniques. The Appendix contains descriptions of several specialised pieces of apparatus made for the present investigation.

DEFINITIONS OF SYMBOLS USED IN THE THESIS

In the Text.

κ = specific conductance.

Λ_m = molar conductance.

c_m = molar concentration.

ϵ = molar extinction coefficient.

In Diagrams.



U-tube trap.



gas reservoir.



vacuum tap.



liquid reservoir.



standard socket.



constriction.



standard cone.



manometer.



rounded end of tubing.

'SOME ASPECTS OF PHOSPHORUS(V) HALIDES'

	Page
<u>PART I</u>	
A Study of Phosphorus Pentabromide.	1
<u>PART II</u>	
The System Phosphorus Tribromide - Bromine.	81
<u>PART III</u>	
Some Triphenoxyphosphorus Dihalides.	128
<u>APPENDICES</u>	
1. The Dry-Box.	208
2. The Vacuum System.	210
3. Conductometric Titration Apparatus.	213
4. Apparatus for the Determination of Transport Numbers.	217
5. Cryoscopic Cell.	223
<u>REFERENCES</u>	228

PHOSPHORUS PENTABROMIDE

SYNOPSIS

PREPARED AND ANALYZED

1. Analytical study of the system Phosphorus Pentabromide - Bromine.
2. Preparation of Pure Phosphorus Pentabromide.

PART I

Synthesis
Pentabromide
Solutions

Quantitative
Analysis

A STUDY OF PHOSPHORUS PENTABROMIDE

Preparation
of Pure Phosphorus

Pentabromide
from Phosphorus
and Bromine

- (a) Phosphorus Pentabromide
(b) Phosphorus Pentabromide

Analysis
of Phosphorus
Pentabromide
in Various Solvents.

- (a) Solutions in Nitrobenzene.
- (b) Solutions in Carbon Tetrachloride.

9. Various Phase Study of Phosphorus

I N D E X

	Page
HISTORICAL NOTE	1 - 8
INTRODUCTION	9 - 11
RESULTS AND DISCUSSION	12 - 59
1. Conductometric Analysis of the System Phosphorus Tribromide - Bromine.	12
2. Preparation of Pure Phosphorus Pentabromide.	19
3. Some X-ray Powder Photographs.	20
4. Molar Conductance of Phosphorus Pentabromide in Acetonitrile Solution.	22
5. Quantitative Electrolysis of Solutions of Phosphorus Pentabromide in Acetonitrile.	27
6. Phosphorus Pentabromide - Group IVB Metal Tetrahalide Complexes.	31
7. Absorption Spectrum of Phosphorus Pentabromide in Various Solvents.	35
(a) Acetonitrile Solutions.	35
(b) Carbon Tetrachloride Solutions.	37
8. A Cryoscopic Study of the System Phosphorus Tribromide - Bromine in Various Solvents.	40
(a) Solutions in Nitrobenzene.	40
(b) Solutions in Carbon Tetrachloride.	51
9. Vapour Phase Study of Phosphorus Pentabromide.	54

	Page
EXPERIMENTAL PART	60 - 80
1. Purification of Materials.	60
(a) Acetonitrile.	60
(b) Nitrobenzene.	61
(c) Carbon Tetrachloride.	62
(d) Phosphorus Pentabromide.	63
(e) Phosphorus Tribromide.	64
(f) Bromine.	67
(g) Phosphorus Oxybromide.	67
(h) Stannic Bromide.	68
2. Preparation of Weighed Samples of Liquids.	68
3. Conductometric Titrations.	69
4. Measurement of Conductance.	70
5. Electrolysis Experiments.	72
6. Absorption Spectra.	73
7. Cryoscopy.	73
8. Vapour Density Measurement.	74
9. X-ray Powder Photography.	79
10. Methods of Analysis.	79

HISTORICAL NOTE

Physicochemical methods have frequently been used in the past for the study of phosphorus pentabromide. By means of colorimetry, Kastle and Beatty [1] investigated the molecular dissociation -



as it occurs in carbon disulphide and carbon tetrachloride solutions. Assuming that the bromine molecule was the only coloured species present they estimated that the degree of dissociation lay between 90 and 100 per cent. They were able to recover the original phosphorus pentabromide by evaporation of the solutions, thus demonstrating the reversibility of the equilibrium. Some time later, the same authors [2] established that a red form of phosphorus pentabromide, previously regarded as an allotropic modification, was in fact phosphorus heptabromide.

Oddo and Tealdi [3] observed the depression of the freezing point of benzene and phosphorus oxychloride, caused by the presence of phosphorus pentabromide in solution. They found that the average molecular weight of the species present in solution was equal to half the

molecular weight of phosphorus pentabromide. From the colour of the solutions the authors infer that dissociation in phosphorus oxychloride is electrolytic -

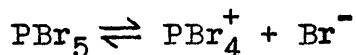

and in benzene the dissociation is assumed to be the molecular one. From these considerations it is concluded that Oddo and Tealdi regard these dissociations as being 100 per cent complete.

Cryoscopy in bromine as solvent has been carried out by Finkelstein [4]. The observed value of molecular weight was equal to the theoretical value when the solution contained 0.8 per cent phosphorus pentabromide; but when the concentration of the solution was increased the molecular weight was also found to increase. The results are explained by assuming the occurrence of complexes produced by solvation and polymerisation.

The properties of electrically conducting solutions of phosphorus pentabromide in non-aqueous solvents have received some attention. Walden [5] has studied the conductance of phosphorus pentabromide in arsenic trichloride and sulphur dioxide, and the values of molar

conductance found were respectively $0.396 \text{ ohm}^{-1} \text{ cm}^2 \text{ mole}^{-1}$ ($c_m = 0.00885$) and $11.36 \text{ ohm}^{-1} \text{ cm}^2 \text{ mole}^{-1}$ ($c_m = 0.00584$).

The presence in these solutions of the P^{5+} ion is suggested according to the following equations :

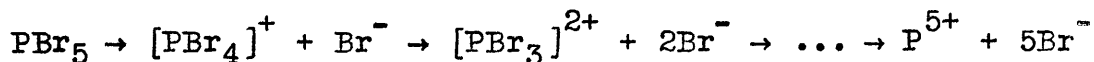

Plotnikov [6] studied the conductance and ionisation of phosphorus pentabromide in bromine solution. He found that the molar conductance attained a maximum value at 21 per cent phosphorus pentabromide corresponding to an overall composition of $PBr_{2.5}$. The solution had a molar conductance of $23.0 \text{ ohm}^{-1} \text{ cm}^2 \text{ mole}^{-1}$ at $c_m = 0.00238$. The scheme of ionisation proposed by Plotnikov differs slightly from that of Walden, in that he introduces the idea of solvation of the phosphorus pentabromide molecule thus :

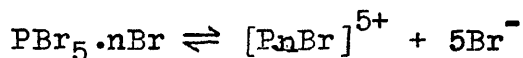

and in particular at the maximum of the molar conductance curve this equation becomes :

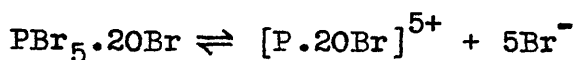

The ionisation of phosphorus pentabromide in bromine

was also studied by Finkelstein [7] by means of the electrolysis of solutions. On the basis of this work and of his cryoscopic investigation of the system, Finkelstein has modified the ionisation scheme proposed by Plotnikov, to make allowance for the observed polymerisation of phosphorus pentabromide in bromine solution :

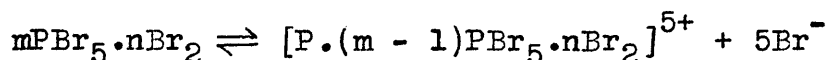

Finkelstein [8] found that a nitrobenzene solution of phosphorus pentabromide had a molar conductance of $0.224 \text{ ohm}^{-1} \text{ cm}^2 \text{ mole}^{-1}$ at $c_m = 0.147$.

Vapour pressure data for phosphorus pentabromide have been made available by Prideaux [9] who, by extrapolation, estimated that the apparent boiling point was 106°C . More recent data has come from the work of Van Driel and Gerding [10] who estimate the heat of sublimation of phosphorus pentabromide to be $13.6 \text{ kg.cal. mole}^{-1}$.

Some thermochemical experiments on the phosphorus - bromine system were carried out by Ogier [11]. He found that the heat of formation of solid phosphorus pentabromide (from solid phosphorus and gaseous bromine) was 83.0 kg.cal . Ogier also determined the heat of

combination of phosphorus tribromide and bromine, and obtained a value of 20.3 kg.cal.

Biltz and Jeep [12] studied the phosphorus tribromide-bromine system by thermal analysis, and the diagram they obtained indicates the existence of two additional polybromides of formulae $\text{PBr}_5 \cdot 2\text{Br}_2$, and $\text{PBr}_5 \cdot 6\text{Br}_2$.

Prideaux [9, 13] estimated the atomic volume of phosphorus in phosphorus pentabromide, and found that it had the value 23.3 ; that is larger than the atomic volume of phosphorus in phosphorus pentachloride (15.1). He also showed that the atomic volume of phosphorus in trivalent compounds is greater than the atomic volume in the corresponding pentavalent compounds.

In recent years the system phosphorus tribromide - bromine has been the subject of radiochemical investigation. Chatterjee [14] prepared phosphorus pentabromide from phosphorus tribromide, containing radioactive bromine, and bromine. The compound was then decomposed thermally and the liberated bromine absorbed in sodium hydroxide solution. The activities of the sodium bromide and the residual phosphorus tribromide were then measured and found to be proportional to the

weights of bromine atoms contained in phosphorus tribromide and bromine. The reaction is represented thus -

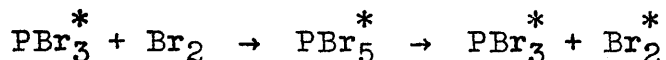

In a second experiment, radioactive phosphorus pentabromide was prepared by exchanging phosphorus pentabromide with irradiated ethyl bromide. The radioactive pentabromide was then decomposed into phosphorus tribromide and bromine, and roughly proportional amounts of activity appeared in the products. Chatterjee concluded that all the bromine atoms in phosphorus pentabromide are functionally equivalent. By taking samples of phosphorus pentabromide and phosphorus tribromide which contain equal gram-atoms of bromine and exchanging them with equal amounts of irradiated ethyl bromide, Chatterjee found that the activity appearing in the phosphorus pentabromide was much greater than that appearing in the phosphorus tribromide. It was concluded that the bonds in phosphorus tribromide are stronger than those in phosphorus pentabromide. A similar series of experiments was carried out by Polesitskiĭ, Yashchenko, and Baranchik [15], and these authors arrived at the same conclusions as did Chatterjee.

Koskoski and Fowler [16] have also studied radio-chemical exchange in this system. They found that the exchange between radio-bromine and phosphorus tribromide was rapid and complete within three minutes thus indicating that the five halogen atoms of the pentahalide are probably equally reactive.

Popov and Schmorrr [17] have investigated the absorption spectrum of phosphorus pentabromide (or more correctly of the complex $\text{PBr}_5 \cdot 2\text{CCl}_4$) dissolved in carbon tetrachloride. The absorption curve obtained was found to be almost identical with that of bromine in the same solvent. The molar extinction coefficient of phosphorus pentabromide was lower than that of bromine by about 7 per cent. Assuming that the absorption spectrum of phosphorus pentabromide is due to bromine, this result is in good agreement with the observations of Kastle and Beatty [1] that phosphorus pentabromide dissociates in carbon tetrachloride to an extent of 90 - 95 per cent.

The assumption that the colour of these solutions is due entirely to free bromine has been invalidated by Popov and Skelly [18] who have found that solutions of phosphorus pentabromide in phosphorus tribromide

have a strong absorption in the wavelength region 400 - 500 $m\mu$ in spite of the fact that the concentration of free bromine in these solutions must be very small. Popov and Skelly made an estimate of the molar extinction coefficient of phosphorus pentabromide and using this value the degree of dissociation of phosphorus pentabromide in carbon tetrachloride was found to be about 50 per cent.

The crystal structure of phosphorus pentabromide has been studied independently by Powell and Clark [19] and Van Driel and McGillavry [20], by means of x-ray diffraction. The results of both groups of workers are in complete agreement. The unit cell is orthorhombic with the dimensions, $a = 5.62 \text{ \AA}$, $b = 16.91 \text{ \AA}$, $c = 8.29 \text{ \AA}$. There are four molecules per unit cell and the space group is $D_{2h}^{11} - Pbcm$. The structure consists of tetrahedral $[PBr_4]$ groups and $[Br]$ units. The P-Br distance in $[PBr_4]$ is 2.20 \AA . (P-Br calculated = 2.24 \AA).

INTRODUCTION

X-ray diffraction studies have revealed that in the solid state, phosphorus pentabromide is an ionic compound and the crystal structure is built up from PBr_4^+ and Br^- units. Thus in the solid state phosphorus pentabromide may be regarded as being completely dissociated in an ionic sense. In the less condensed states of matter the situation is different and the dissociation of phosphorus pentabromide is known to yield bromine and phosphorus tribromide, but there are no numerical data in the literature about these states. However it seems likely that the dissociation of phosphorus pentabromide in the liquid and vapour phase is almost 100 per cent complete.

The structure of an undissociated phosphorus pentabromide molecule is not well understood, and in point of fact such an entity appears to be a relatively rare occurrence. The only evidence available on this point is contained in the radio-chemical papers in which it is claimed that the phosphorus pentabromide molecule contains five functionally equivalent bonds.

The physical state therefore determines the structure

of phosphorus pentabromide. The ionic form is stable when the field of neighbouring atoms is strong : the molecular form ($\text{PBr}_3 + \text{Br}_2$) is stable when neighbouring groups of atoms are sufficiently separated so as to have very little mutual influence.

The case of solutions of phosphorus pentabromide is interesting since the solvent can be varied from one which ought to favour a molecular dissociation to one which would induce ionisation. Work has been done on both types and it has been found that in solvents like carbon tetrachloride and carbon disulphide, of zero dipole moment, the phosphorus pentabromide dissociates into bromine and phosphorus tribromide. But with solvents of higher dielectric constant such as arsenic trichloride and sulphur dioxide, the solutions were found to conduct electricity, thus indicating the presence of an ionic dissociation.

Therefore by using these different classes of solvents, the factors present in the gaseous or liquid state on the one hand and the solid state on the other have been reproduced (in part at least).

The present study is an investigation of the properties of non-aqueous solutions of phosphorus penta-

bromide and is designed to relate the ionisation occurring in solution to the crystal structure of the compound. The solvent chosen was acetonitrile which has very favourable dielectric properties; and its ability to act as a Lewis base frequently results in ion-stabilisation. It was thought that in this solvent, phosphorus pentabromide would be ionised to quite a considerable degree.

In addition to the study of solutions of phosphorus pentabromide it was thought desirable that some data should be collected on the composition of the vapour phase of the compound, and to this end vapour density measurements were made.

RESULTS AND DISCUSSION

CONDUCTOMETRIC ANALYSIS OF THE SYSTEM, PHOSPHORUS
TRIBROMIDE - BROMINE.

The system phosphorus tribromide - bromine was studied in acetonitrile solution by the method of conductometric titration. The results of this investigation are set out in Table 1. and are shown graphically in Fig. 1.

Table 1. Conductometric analysis of the system
PBr₃ - Br₂ in acetonitrile solution.

Mole Ratio Br ₂ :PBr ₃	10 ⁴ κ ohm ⁻¹ cm ⁻¹	Mole Ratio Br ₂ :PBr ₃	10 ⁴ κ ohm ⁻¹ cm ⁻¹
0.00	0.32	1.53	4.32
0.22	1.13	1.75	4.35
0.44	2.66	2.18	4.65
0.65	3.32	2.73	4.78
0.87	3.82	3.27	4.98
1.09	4.05	3.82	5.15
1.31	4.15		

The conductance of phosphorus tribromide and bromine

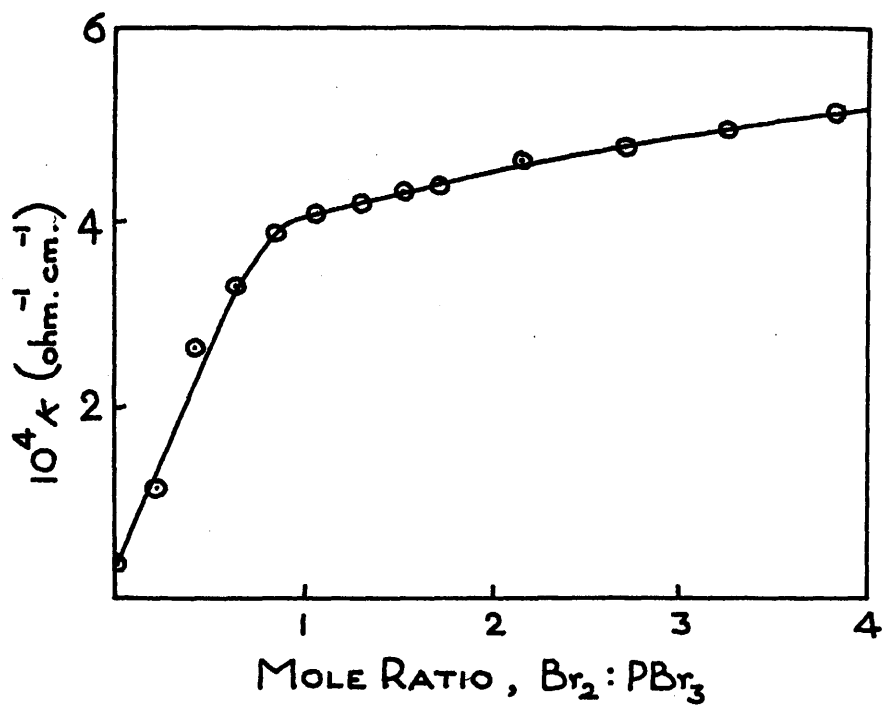

Fig. 1. Conductometric Analysis of the System
 $\text{PBr}_3 - \text{Br}_2$ in acetonitrile.

in acetonitrile have been determined in separate experiments and it has been found that both these compounds are virtually non-conductors in this solvent. The actual values found were :

$$\begin{array}{l} \text{PBr}_3, \Lambda_m = 1.78 \text{ ohm}^{-1} \text{ cm}^2 \text{ mole}^{-1} \quad c_m = 0.025 \\ \text{Br}_2, \Lambda_m = 0.22 \quad " \quad " \quad " \quad c_m = 0.033 \end{array}$$

It is therefore evident that the reaction of bromine and phosphorus tribromide in acetonitrile is accompanied by the production of ions. The form of the graph, with its abrupt change of slope at a mole ratio of 1, indicates the presence in the solution of an ionic complex with the composition $\text{PBr}_3 \cdot \text{Br}_2$. In other words, it has been shown that phosphorus pentabromide behaves as an electrolyte and undergoes ionisation in acetonitrile.

Considerable interest attaches to the configuration of the graph at the mole ratios 2 and 3 in view of the reported hepta- and ennea- bromides of phosphorus [2, 12]. The absence of inflections in the curve at these ratios suggests that the solution does not contain any new type of ion derived from a hepta- or ennea- bromide, but is simply a solution of phosphorus

pentabromide plus excess bromine. Therefore dissolution of a higher bromide in acetonitrile would bring about its dissociation thus :

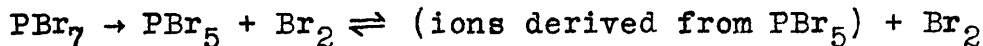

If phosphorus pentabromide is represented in solution by the same ions as in the solid state, namely PBr_4^+ and Br^- , then it would appear that the conditions (...onium type cation [21] in acetonitrile solution [22]) were favourable for the formation of the tribromide ion (at the mole ratio corresponding to PBr_7). However the absence of an inflection on the graph beyond the mole ratio 1 seems to indicate that the process :-

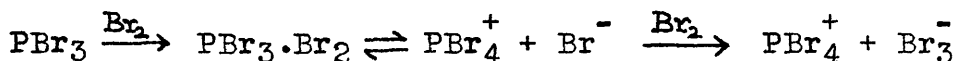

is not taking place.

It therefore appears reasonable to suggest at this stage that phosphorus pentabromide does not ionise in acetonitrile in the manner shown in the above scheme. It is possible that the ions present are analagous to those occurring in acetonitrile solutions of phosphorus pentachloride, namely PCl_4^+ and PCl_6^- [23]. The system would then be represented thus :

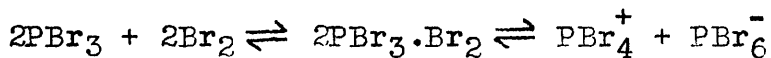

If this is the case then addition of bromine beyond the 1:1 mole ratio can lead to two possible changes. Firstly a break down of the PBr_6^- ion might occur thus -



or secondly the added bromine may remain in the solution without changing the ion type.

The first of these possibilities is excluded since it involves a doubling in the total number of ions and this situation would be reflected in the specific conductance - mole ratio diagram by a steep rise in conductance up to the mole ratio of 2. This is not observed hence it is concluded that the solution probably contains the PBr_6^- ion and that addition of bromine to the solution does not alter this in any way.

Although the suggestion that the ions present in acetonitrile solutions of phosphorus pentabromide are not the same as those found in the solid state is a fairly reasonable one, the idea that the ions are analagous to those present in solutions of the pentachloride is purely speculative and requires substantiation from ion migration experiments.

This experiment also shows that the equilibrium -

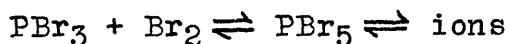

is rapidly established, and this is in agreement with the conclusions of Kastle and Beatty [1]. The slight rise in the value of specific conductance after the unit mole ratio is attributed to the influence of excess bromine on the degree of ionisation of phosphorus pentabromide operating by displacing the above equilibrium to the side of the ions.

The Preparation of Phosphorus Pentabromide in an Acetonitrile Medium.

As a corollary to the previous experiment it was decided to investigate the suitability of acetonitrile as a medium for the synthesis of phosphorus pentabromide. Bromine was added to an acetonitrile solution of phosphorus tribromide until the mole ratio 1:1 was reached. The limited solubility of phosphorus pentabromide in acetonitrile caused its precipitation in good yield. The product was pale yellow and crystalline, and the results of analysis were as follows :-

Found : P, 7.22 ; Br, 92.26 %.

Calculated for PBr_5 : P, 7.19 ; Br, 92.81 %.

The formation of a pure precipitate confirms that acetonitrile is a suitable solvent for use in preparing phosphorus pentabromide, and this method has certain obvious advantages over that which uses carbon disulphide as solvent.

Physical measurements were made on the sublimation of the crude material and the results are given in Table I. It was carried out in a glass apparatus under varying conditions of temperature and pressure. The color of the sublimate was heterogeneous, from white to pale yellow, and in an average sublimation yield a better figure than that obtained by the usual method.

The idea of using sublimation as a method of purification is well known.

PREPARATION OF PURE PHOSPHORUS PENTABROMIDE.

The starting material was the phosphorus pentabromide supplied in glass ampoules by B.D.H., Ltd. This material was submitted to a bromine analysis (hydrolysis followed by Volhard's method) which served as an indication of its purity. The result obtained was :-

Found : Br, 90.55 %.

Calculated for PBr_5 : Br, 92.81 %.

Thus the compound requires careful purification before physical measurements can be made upon it.

Sublimation of the crude material was the first method tried. It was carried out in a vacuum cold-finger apparatus under varying conditions of temperature gradient and pressure. In each instance the colour of the sublimate was heterogeneous, varying from white to pale yellow, and in no experiment did the sublimed material yield a better figure for the bromine content than : Br = 89.58 %.

Thus the idea of using sublimation as a means of purifying phosphorus pentabromide was in the meantime

discarded. It is noteworthy that Van Driel and Gerding [10] found that the vapour pressure of sublimed phosphorus pentabromide was not reproducible. It seems that the impurity present in the crude material is about as volatile as the pentabromide.

The other method of purification tried was crystallisation, and in this connection advantage was taken of previous work done by Van Driel and Gerding [10] who used nitrobenzene as the crystallisation medium. An attempt was made however to find a more suitable solvent, and in doing so all the main types of non-reactive organic liquids were examined. These included acetonitrile, benzonitrile, benzene, dioxan, carbon tetrachloride, ethylene dibromide, bromoform, and ethyl bromide. From this series no solvent was found which excelled nitrobenzene from the point of view of solvent power and inertness. The main disadvantage of nitrobenzene is its very low volatility.

Phosphorus pentabromide was recrystallised from carefully purified nitrobenzene and stored in stoppered tubes kept in a desiccator. Analysis of the material gave the following results :-

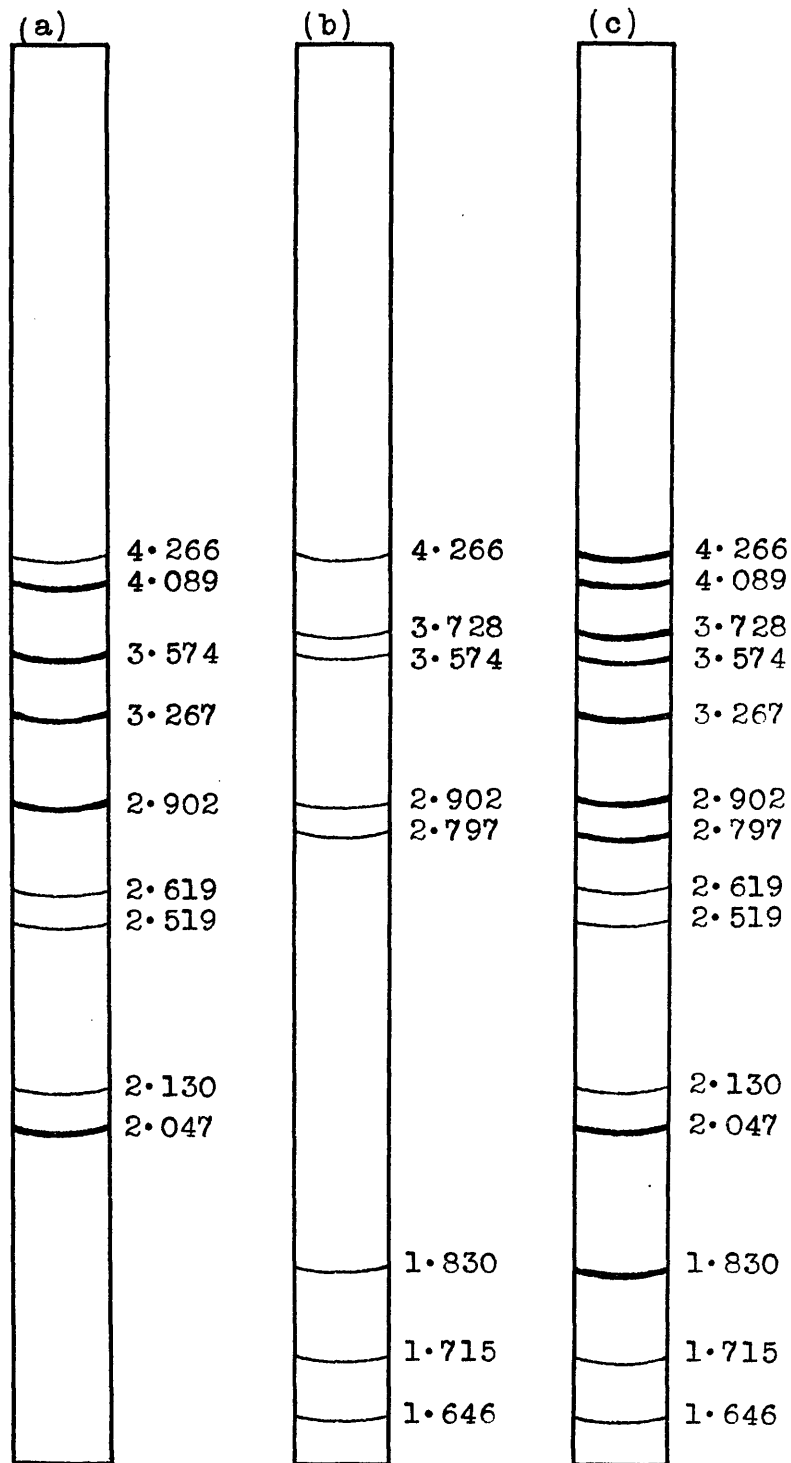

Fig. 2. Powder Photographs (The figure beside each line is the d-spacing in Angstrom Units.)

MOLAR CONDUCTANCE OF PHOSPHORUS PENTABROMIDE IN
ACETONITRILE SOLUTION

The conductance of phosphorus pentabromide in acetonitrile was studied using a pipette cell designed in such a way that the solutions could be manipulated out of direct contact with the humid atmosphere. Several solutions of different concentrations were studied and the results are recorded in Table 2 and Fig. 3.

The specific conductance of the solutions was found to increase slightly with time, and therefore to introduce uniformity into the choice of specific conductance (κ) used to calculate molar conductance (Λ_m), the specific conductance was plotted against time, and extrapolated to $t = 0$ (i.e. the time when the solution was just prepared), and the value of specific conductance at this point was used.

A conductance drift has been observed by Popov and Skelly [24] during a study of acetonitrile solutions of interhalogen compounds. They attributed the steady rise of specific conductance with time to a slow ion-

isation of the type -

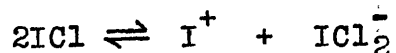

Table 2. Conductance of phosphorus pentabromide in acetonitrile at 25 °C.

c_m mole.litre ⁻¹	$10^4 \kappa$ ohm ⁻¹ cm ⁻¹	Λ_m ohm ⁻¹ cm ² mole ⁻¹
0.0152	2.12	13.95
0.0195	2.78	14.25
0.0296	3.63	12.26
0.0721	5.67	7.86

As can be seen from Fig. 3, these values when plotted against the square root of the molar concentration fall on a straight line of negative slope. At values of c_m less than about 0.015, the values of Λ_m were irregular and very unreproducible. This is presumably due to the enhanced influence of traces of impurities when working at such low concentrations. The molar conductance at a given concentration was observed to vary slightly from batch to batch of acetonitrile, but within the same

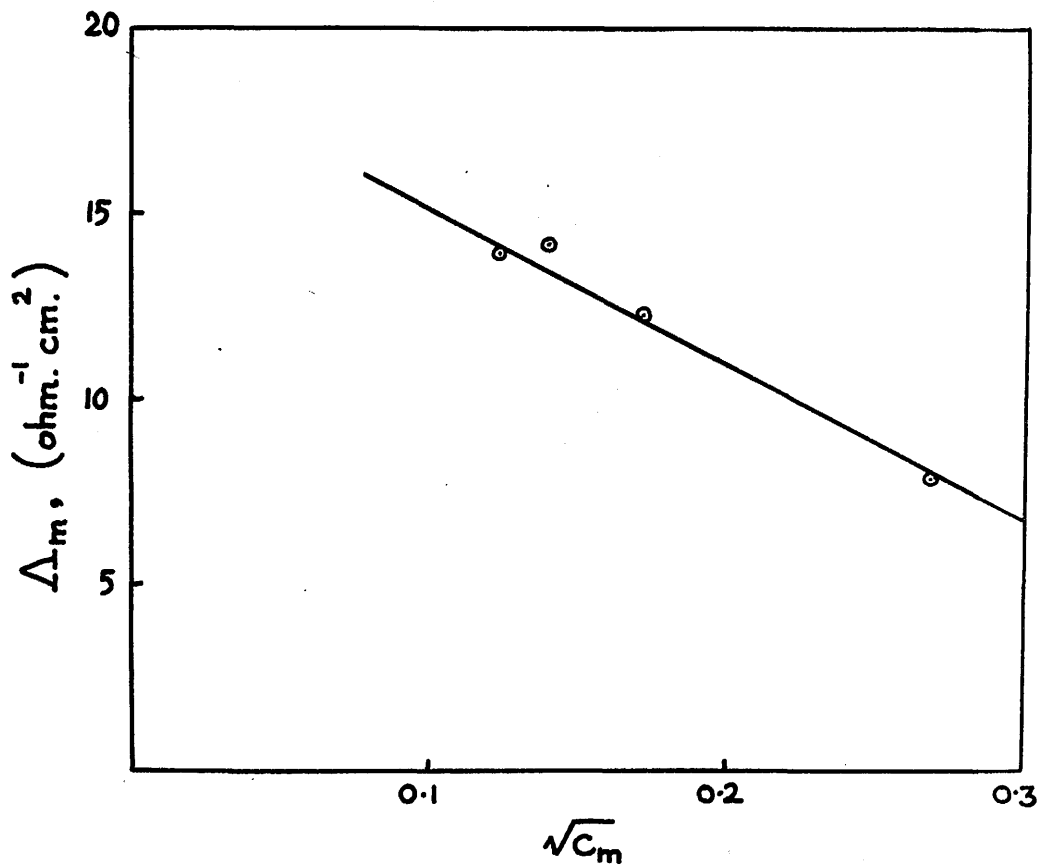

Fig. 3. Conductance of phosphorus pentabromide in acetonitrile.

lot of solvent the values formed a consistent series.

Solutions of phosphorus pentabromide in acetonitrile were found to have a positive temperature coefficient within the range 0 - 25 °C.

It is possible that in acetonitrile solutions phosphorus pentabromide might undergo molecular dissociation to a certain extent. Therefore these conducting solutions might contain phosphorus tribromide and bromine molecules. That these molecules do not contribute significantly to the conductance of the solutions has already been demonstrated. (Values of the molar conductance of these compounds in acetonitrile are given on page 14.)

Clearly then we must regard the conductance of these solutions as being the consequence of the electrolytic behaviour of phosphorus pentabromide.

The general stability of acetonitrile as a solvent for phosphorus pentabromide is demonstrated by the fact that the cooling of such a solution yields analytically pure phosphorus pentabromide.

In contrast with antimony pentachloride which forms

solvates of the type $SbCl_5 \cdot CH_3CN$, [25], no evidence has been obtained for the formation of solid solvates of phosphorus pentabromide and acetonitrile. In this respect therefore phosphorus pentabromide resembles phosphorus pentachloride [23].

It is interesting to note that phosphorus pentachloride forms a solid solvate with acetonitrile, $PCl_5 \cdot CH_3CN$, [25]. The formation of this solvate is accompanied by a color change from yellow to orange-red.

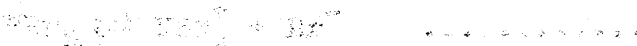

On the other hand the dissociation may be the dissociation of phosphorus pentachloride into PCl_4^+ and Cl^- ions [23],

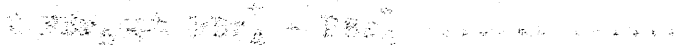

It is interesting to note that one of these substances is a solid solvate. It is necessary to check the conductivity of the solution at each electrode.

QUANTITATIVE ELECTROLYSIS OF SOLUTIONS OF PHOSPHORUS
PENTABROMIDE IN ACETONITRILE

This experiment was performed in the specially designed cell described in detail in Appendix 4. It was hoped that the result of this experiment might lead to a knowledge of the nature of the ions present in acetonitrile solutions of phosphorus pentabromide.

Two modes of ionisation of phosphorus pentabromide would appear to be plausible. In the first place the ionisation might involve the ions present in the solid state thus,



On the other hand the dissociation may be analagous to the ionisation of phosphorus pentachloride in the same solvent [23],

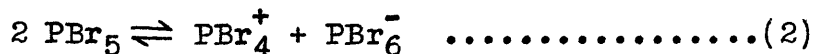

To determine whether one of these schemes is the correct one it is necessary to observe the changes in composition of the solution at each electrode for the passage of a known amount of current.

Suppose,

ΔBr = increase in g. atoms of Br at cathode.

ΔP = " " " " P " .

t_+ = transport number of cation.

x = quantity of current passed (in Faradays).

then for ionisation (1), provided no phosphorus or bromine is lost from the solution during electrolysis, the following relationships hold,

$$\Delta Br = x(5t_+ - 1)$$

$$\Delta P = -xt_+$$

and for ionisation (2),

$$\Delta Br = x(10t_+ - 6)$$

$$\Delta P = x(1 - 2t_+)$$

When $x = 1$ these expressions give rise to the following ranges of values of ΔBr or ΔP .

Ionisation (1) :-

t_+	0	0.1	0.2	0.3	0.4	0.5	0.6	0.7	0.8	0.9	1.0
ΔBr	-1	-0.5	0	+0.5	+1.0	+1.5	+2.0	+2.5	+3.0	+3.5	+4.0
ΔP	0	-0.1	-0.2	-0.3	-0.4	-0.5	-0.6	-0.7	-0.8	-0.9	-1.0

Ionisation (2)

t_+	0	0.1	0.2	0.3	0.4	0.5	0.6	0.7	0.8	0.9	1.0
ΔBr	-6	-5	-4	-3	-2	-1	0	+1	+2	+3	+4
ΔP	+1	+0.8	+0.6	+0.4	+0.2	0	-0.2	-0.4	-0.6	-0.8	-1

The concentration changes (for 1 Faraday of current) obtained in two separate experiments gave the values of t_+ shown in Table 3.

Table 3. Transport Numbers for Phosphorus Pentabromide.

Expt. No.	Δ in g. atoms.	t_+	
		Ionisn. (1)	Ionisn. (2)
1	$\Delta\text{Br} = -0.59$	0.08	0.55
	$\Delta\text{P} = -0.13$	0.13	0.57
2	$\Delta\text{Br} = -0.67$	0.07	0.54
	$\Delta\text{P} = +0.14$	-0.13	0.44

Thus the more concordant set of results is obtained in the consideration of ionisation (2). The numerical value of the transport number t_+ strongly supports the idea that the ionic system must be described in terms of scheme (2), for in systems in which

the passage of current does not occur through a chain-transfer process, the transport numbers of the ions are found to be approximately equal (i.e. ca. 0.5). Since in the present system a chain mechanism of conduction (involving the solvent) is not possible then the value of t_+ would be expected to be in the region of 0.5. In the second experiment the observed diminution in the amount of phosphorus in the cathode region can be explained only on the basis of a phosphorus-containing anion.

It therefore seems certain that phosphorus pentabromide undergoes ionisation in acetonitrile solution according to the following scheme -

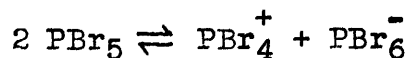

This is therefore an example of a compound which in the solid state has a stable ionic structure different from that which is stable in solution. In this connection it is necessary to bear in mind the effect of the solvent in the stabilisation of the ionic species in solution.

PHOSPHORUS PENTABROMIDE - GROUP IVB METAL TETRAHALIDE
COMPLEXES

This subject was investigated to find out whether phosphorus pentabromide resembled the pentachloride in its ability to form ionic complexes with Group IVB metal tetrahalides. Payne [26] has shown that non-aqueous solutions of the compounds $\text{SnCl}_4 \cdot \text{PCl}_5$ and $\text{SnCl}_4 \cdot 2\text{PCl}_5$ are highly conducting, and has established that this cannot be explained on the basis of a molecular dissociation of the complex followed by ionisation of the components thus :

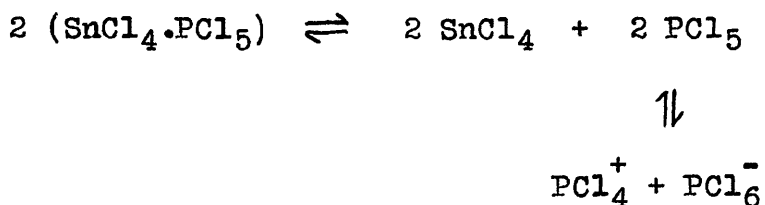

There is evidence which suggests that the 1:2 complex ionises in acetonitrile solution with the production of the ions PCl_4^+ and SnCl_6^- .

The present exploratory experiment with phosphorus pentabromide and stannic bromide was carried out in an attempt to discover if this system could form a parallel

series of compounds. The system was studied by conductometric titration in acetonitrile and the results are given in Table 4 and Fig. 4

Table 4. Conductometric Analysis of the System

PBr₅ - SnBr₄ in acetonitrile.

Mole Ratio PBr ₅ :SnBr ₄	10 ⁴ κ ohm ⁻¹ cm ⁻¹	Mole Ratio PBr ₅ :SnBr ₄	10 ⁴ κ ohm ⁻¹ cm ⁻¹
0	0.31	1.53	4.69
0.08	2.13	1.72	4.69
0.19	3.15	1.91	4.69
0.38	3.62	2.10	4.73
0.57	3.90	2.30	4.73
0.77	4.33	2.48	4.81
0.96	4.49	2.68	4.81
1.15	4.57	2.87	4.92
1.34	4.61	3.06	5.12

These results establish that phosphorus pentabromide forms two distinct ionic complexes with stannic bromide and these have the formulae SnBr₄.PBr₅ and SnBr₄·2PBr₅.

That is two types of complexes are present as in the

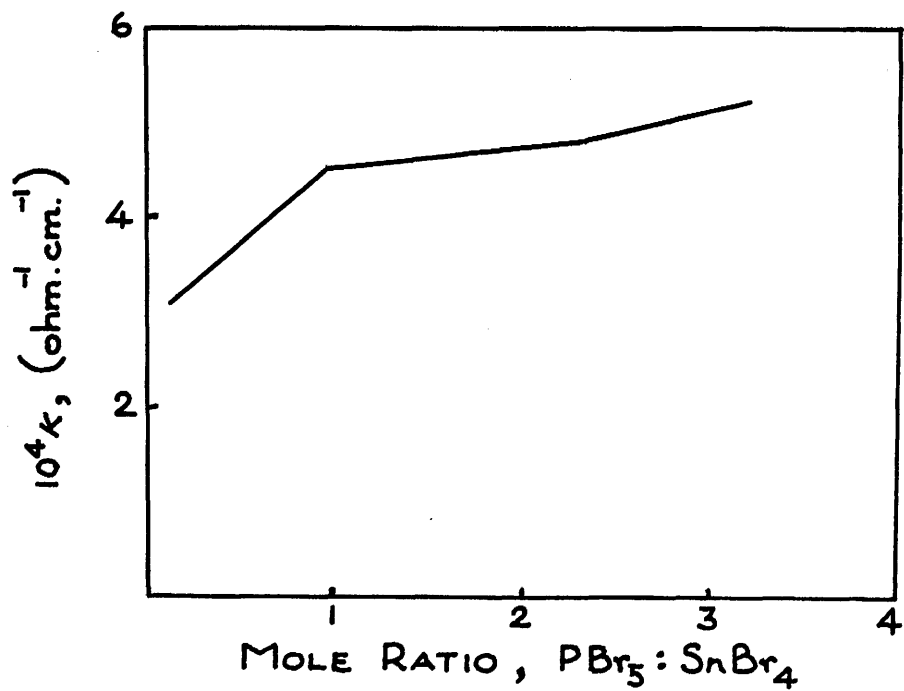

Fig. 4. Conductometric Analysis of the System
PBr₅ - SnBr₄ in acetonitrile.

phosphorus pentachloride - stannic chloride system. There is no definite information about the structure of the ions and no attempt has been made to isolate either of the complexes.

It therefore seems that there may exist a series of complex bromides based on phosphorus pentabromide.

The following observations were made in the course of the investigation of the phosphorus pentabromide - stannic chloride system. The results are given in Table I. The concentration of the absorbing species is a function of the concentration of phosphorus pentabromide. Consequently the value of the molar absorptivity varies with the concentration of phosphorus pentabromide.

The absorption curve of bromine in carbon tetrachloride is a straight line. The curve shows a maximum at 440 m μ . The curve shows a minimum at 480 m μ .

ABSORPTION SPECTRUM OF PHOSPHORUS PENTABROMIDE IN
VARIOUS SOLVENTS

(1) Acetonitrile Solutions.

Three solutions of different concentration were prepared and their visible and ultra-violet absorption measured. For comparison the spectrum of bromine in the same solvent was determined. The curves obtained are shown in Fig. 5.

The discontinuous nature of the absorption curve of phosphorus pentabromide is evidence that the absorbing species are members of a dissociating system. Thus due to the equilibrium shifting on dilution the concentration of the absorbing species is not proportional to the molar concentration of phosphorus pentabromide. Consequently the value of the molar extinction coefficient varies with the concentration of the solution.

The absorption curve of bromine in acetonitrile is not as simple as that for a carbon tetrachloride solution of bromine. The curve shows a shift of the first maximum towards shorter wavelengths. This is

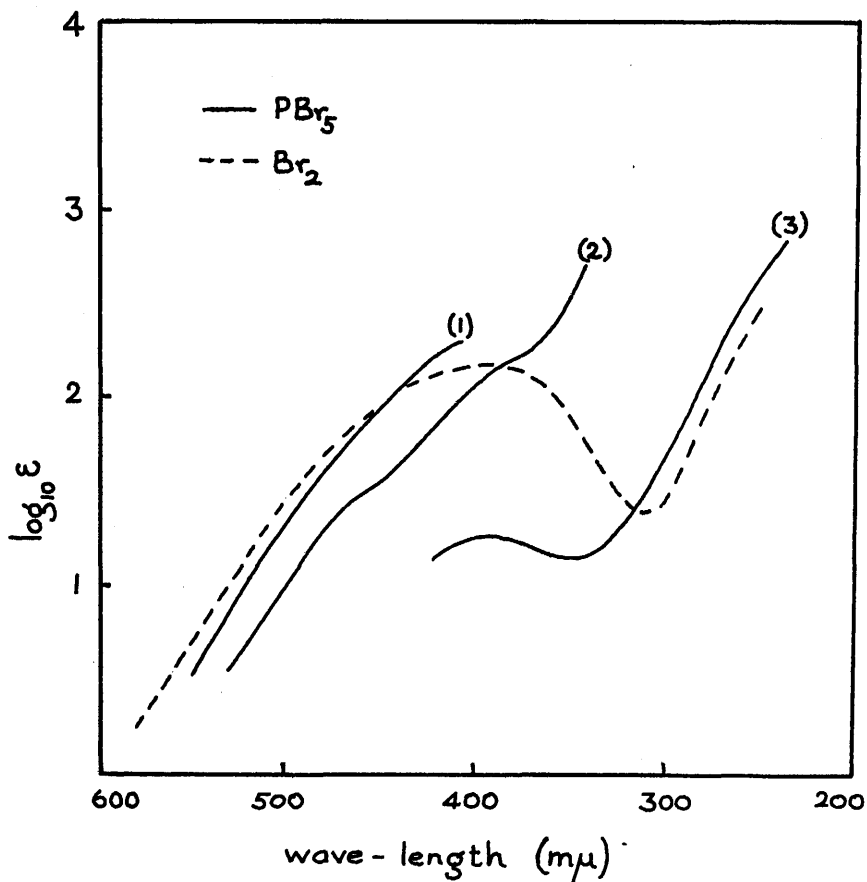
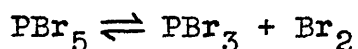

Fig. 5. Absorption Spectrum of PBr_5 in CH_3CN .

Molar Concentration, (1) = 0.01170
(2) = 0.00370
(3) = 0.00264

similar to the behaviour of iodine in polar and non-polar solvents.

The first maximum in the absorption spectrum of bromine is at $395\text{m}\mu$, and in the spectrum of phosphorus pentabromide an inflection is found at this wavelength on each curve. Hence it is concluded that bromine molecules are absorbing, and therefore in acetonitrile solution, phosphorus pentabromide must undergo molecular dissociation -



to a certain extent, as well as the electrolytic dissociation already demonstrated.

Beyond this conclusion the problem becomes too complex due to the possibility of absorption by the ions.

(2) Carbon Tetrachloride Solutions.

The absorption spectrum of phosphorus pentabromide in carbon tetrachloride was redetermined, and in Fig. 6 the result is compared with the curve obtained by Popov and Schmorrr [17].

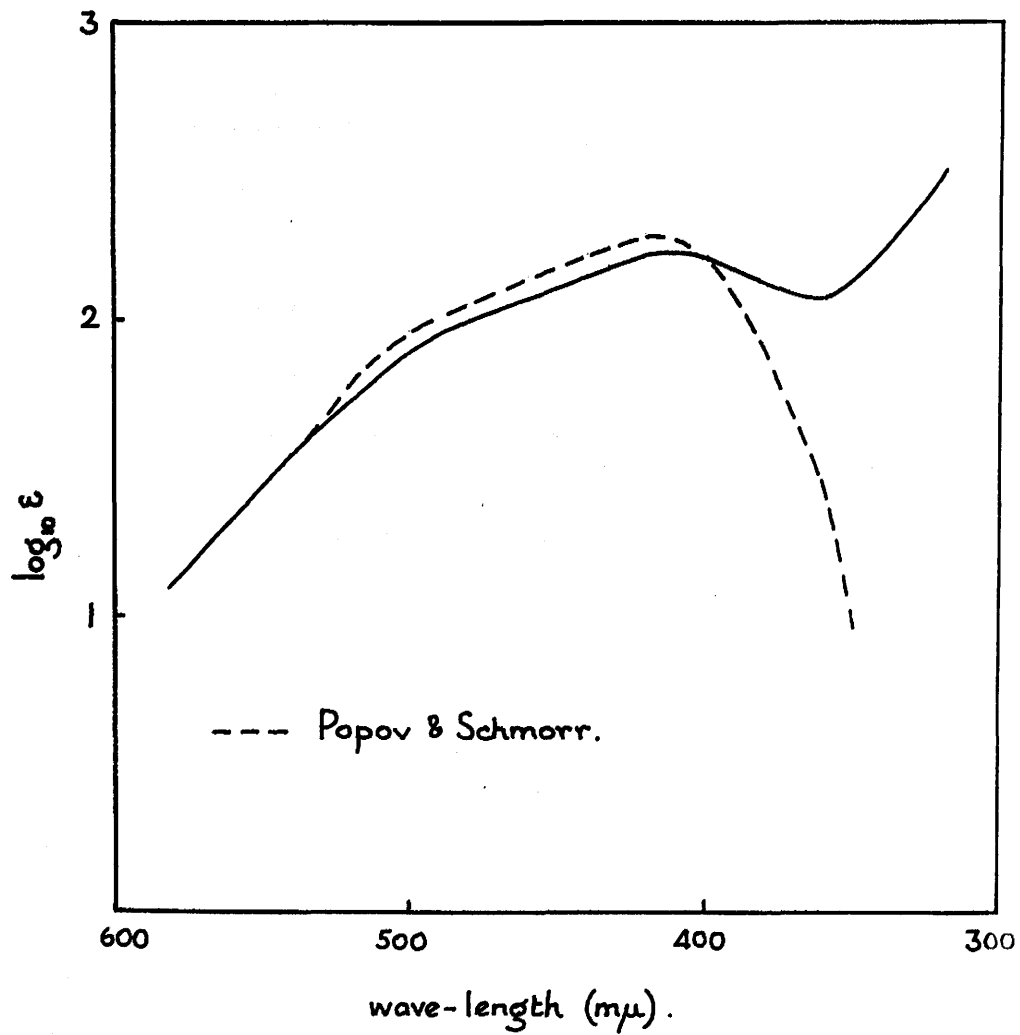

Fig. 6. Absorption Spectrum of PBr₅ in CCl₄.

It is seen that these curves are almost identical up to the maximum of absorption (410 $m\mu$) but vary considerably in the shorter wavelength region.

Some absorption curves of bromine in carbon tetrachloride were collected from the literature and compared with the absorption spectrum as determined by Popov and Schmorrr [17]. These were all in good agreement up to the maximum, but from this point to shorter wavelengths, the curves showed diverse shapes.

Considering phosphorus pentabromide solutions, if it is assumed that only bromine is absorbing, then the degree of dissociation of phosphorus pentabromide in carbon tetrachloride may be calculated, provided Beer's Law holds for the particular wavelength used. This was done for the absorption at 500 $m\mu$ (using the absorption spectrum of bromine in carbon tetrachloride found by Aickin, Bayliss, and Rees [27]) and it was calculated that the degree of dissociation was 90.5 %. The same result was arrived at by Kastle and Beatty [1] and by Popov and Schmorrr [17]. The assumption that bromine is the only absorbing species is very questionable since it would be expected that the phosphorus pentabromide molecule would absorb in this region of wavelength.

A CRYOSCOPIC STUDY OF THE SYSTEM PHOSPHORUS TRIBROMIDE -
BROMINE IN VARIOUS SOLVENTS

1. SOLUTIONS IN NITROBENZENE.

Solutions of phosphorus pentabromide in nitrobenzene have previously been studied by Finkelstein [8] who found that the conductance of the solutions was very small ($\Lambda_m = 0.224 \text{ ohm}^{-1} \text{ cm}^2 \text{ mole}^{-1}$, $c_m = 0.147$). It is concluded that the electrolytic dissociation of phosphorus pentabromide in this solvent is negligible. A cryoscopic investigation of the phosphorus tribromide-bromine - nitrobenzene system would therefore be expected to yield some information of the extent of molecular dissociation of phosphorus pentabromide in nitrobenzene. The apparatus used in this investigation is described in Appendix 5.

The problem was approached from the $\text{PBr}_3 + \text{Br}_2$ side of the equilibrium. Freezing points were determined first of all for phosphorus tribromide in nitrobenzene and then for this solution containing added amounts of bromine. These values are shown in Table 5 and the linear relationship found between freezing point

and the mole ratio $\text{Br}_2 : \text{PBr}_3$ (PBr_3 being constant) is illustrated in Fig. 7.

Table 5. Freezing Points in the System $\text{PBr}_3 - \text{Br}_2 - \text{C}_6\text{H}_5\text{NO}_2$.

Mole Ratio $\text{Br}_2:\text{PBr}_3$	Freezing Pt. (Relative)
0	5.103
0.3677	4.961
0.7867	4.809
1.2246	4.636
1.7463	4.445
2.3735	4.221

From the experimental data and using $7 \cdot 10^*$ as the cryoscopic constant of nitrobenzene [28] it is possible

* The cryoscopic constant of nitrobenzene used here appeared to be satisfactory in that the observed molecular weight for phosphorus tribromide in solution was 271.2 (Calculated molecular weight = 270.7). It is interesting to note that Larsen and Wittenburg [29] who studied nitrobenzene solutions of complexes of the type $\text{MCl}_4 \cdot 2\text{POCl}_3$ (M = Zr, Hf) used the rather lower value of 6.79 .

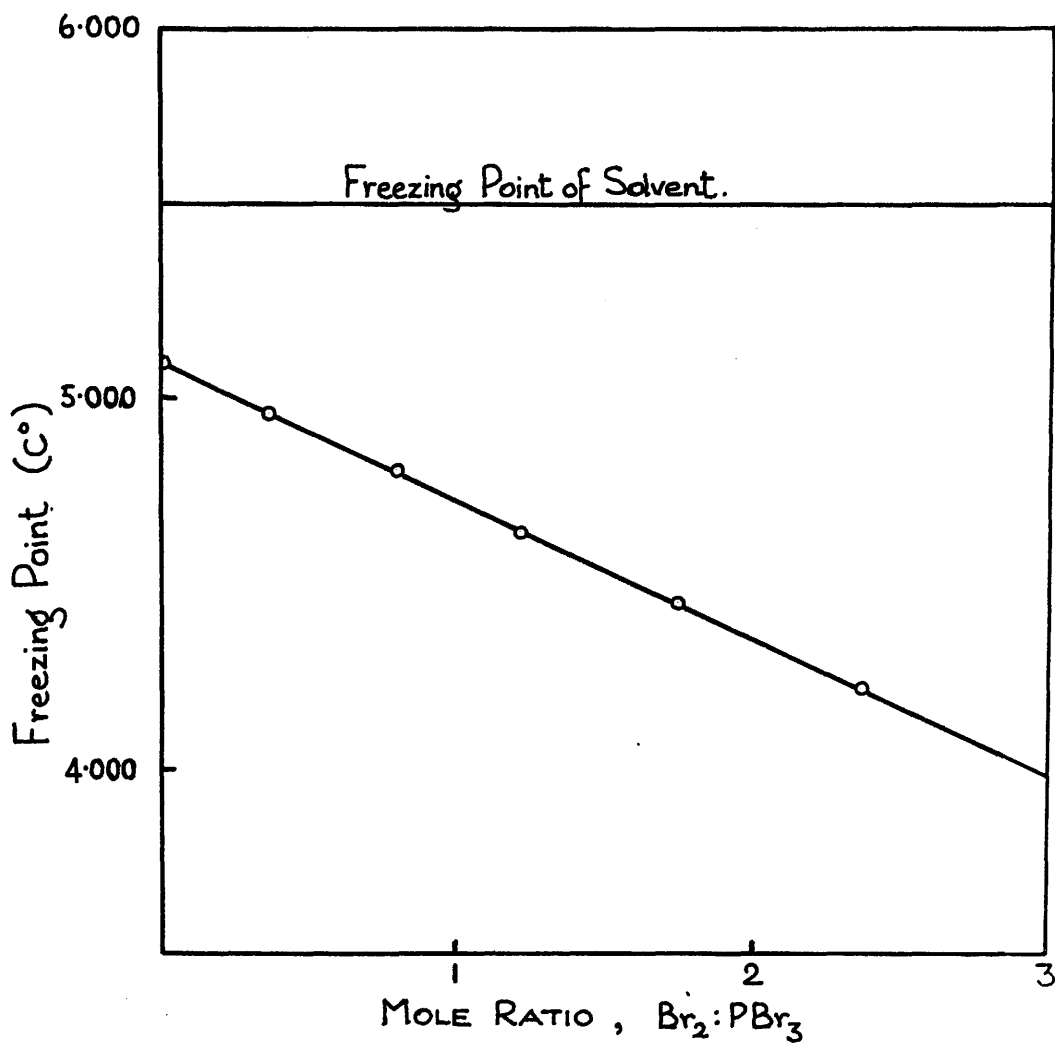

Fig. 7. Freezing Points in the System PBr₃ - Br₂ - nitrobenzene.

to calculate the number (n) of particles present in the solution at any mole ratio.

Note. In order to facilitate the calculations, consideration was given only to integral mole ratios and the freezing point at these ratios was obtained from the graph.

Consideration of the Equilibrium, $\text{PBr}_3 + \text{Br}_2 \rightleftharpoons \text{PBr}_5$

Let, ${}_1K_1$ = association constant.

x = moles of PBr_3 present at the start.

α_1 = degree of association of PBr_3 and Br_2 .

${}_1n$ = number of particles present in the solution at the 1:1 ratio.

V = the volume of the system.

then for the equilibrium,



the expression for the association constant is

$${}_1K_1 = \frac{V(2x - {}_1n)}{({}_1n - x)^2}$$

and for a onefold and twofold excess of bromine in the system (i.e. at mole ratios 2 and 3) the corresponding expressions are -

$${}_2K_1 = \frac{V^2(3x - {}_2n)}{x({}_2n - 2x)({}_2n - x)} \quad ; \quad {}_3K_1 = \frac{V^3(4x - {}_3n)}{x^2({}_3n - 3x)({}_3n - x)}$$

(Note : the antecedent subscript denotes the appropriate mole ratio Br₂/PBr₃, e.g. ₃n = number of particles in the solution at mole ratio = 3)

A similar consideration of the equilibria -

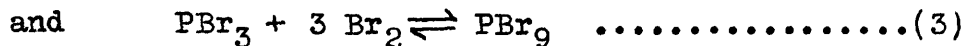

enables us to write down the following set of expressions in which the symbols are self explanatory :-

Equilibrium (2),

$${}_1K_2 = \frac{Vx(2x - {}_1n)}{{}_1n({}_1n - x)^2} \quad ; \quad {}_2K_2 = \frac{V^2(3x - {}_2n)}{({}_2n - x)^3}$$

$${}_3K_2 = \frac{V^3(4x - {}_3n)}{x({}_3n - 2x)({}_3n - x)^2}$$

Equilibrium (3),

$${}_1K_3 = \frac{Vx^2(2x-n)}{(x+n)(n-x)^3} \quad ; \quad {}_2K_3 = \frac{V^2x(3x-2n)}{{}_2n(n-x)^3}$$

$${}_3K_3 = \frac{V^3(4x-3n)}{({}_3n-x)^4}$$

Now substitution of the experimental results into these nine expressions ought to reveal which equilibrium describes the system most closely. The result of doing this is summarised in Table 6.

Table 6. Association Constants for the Equilibria.

PBr ₅	PBr ₇	PBr ₉
${}_1K_1 = 2.208$	${}_1K_2 = 16.112$	${}_1K_3 = 164.2$
${}_2K_1 = 2.246$	${}_2K_2 = 8.289$	${}_2K_3 = 41.13$
${}_3K_1 = 2.731$	${}_3K_2 = 5.570$	${}_3K_3 = 17.91$

From these results it is clear that the equilibrium,

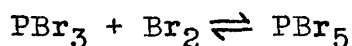

describes the system better than any other single equilibrium.

The values of degree of association for equilibrium (1) are :-

$${}_1\alpha_1 = 0.1238$$

$${}_2\alpha_1 = 0.2408$$

$${}_3\alpha_1 = 0.3462$$

An analysis of the results was carried out in an attempt to discover if the system could be described more completely by considering that the true state of affairs was one in which a mixture of equilibria (1) and (2) was present. This was done by introducing a parameter \mathcal{X} to relate the expressions for the two equilibria.

\mathcal{X} is defined as being equal to $\left(\frac{V}{x}\right)_{rK_1}$ where $r = 1, 2, 3$ (i.e. the mole ratio Br_2/PBr_3) and it is obvious that the value of this expression must be constant. Therefore we can obtain three expressions for \mathcal{X} involving the degrees of association thus -

$$\mathcal{X} = \left(\frac{V}{x}\right)_{1K_1} = \frac{{}_1\alpha_1}{{}_1\alpha_2} \left[1 - (\alpha_1 + 2\alpha_2) \right]$$

$$\mathcal{X} = \left(\frac{V}{x}\right)_{2K_1} = \frac{{}_2\alpha_1}{{}_2\alpha_2} \left[2 - (\alpha_1 + 2\alpha_2) \right]$$

$$\mathcal{X} = \left(\frac{V}{x}\right)_{3K_1} = \frac{{}_3\alpha_1}{{}_3\alpha_2} \left[3 - (\alpha_1 + 2\alpha_2) \right]$$

Now using the following expressions involving ${}_r\alpha_1$ and ${}_r\alpha_2$ -

$${}_1\alpha_1 + 2{}_1\alpha_2 = \frac{2x - 1n}{x} \quad ; \quad {}_2\alpha_1 + 2{}_2\alpha_2 = \frac{3x - 2n}{x}$$

$${}_3\alpha_1 + 2{}_3\alpha_2 = \frac{4x - 3n}{x}$$

it becomes possible to calculate the numerical values of ${}_r\alpha_1$ and ${}_r\alpha_2$ for any arbitrary value of \mathcal{K} . From there it is possible to arrive at a set of values of ${}_rK_1$ and ${}_rK_2$ for different values of \mathcal{K} . (Table 7.). Therefore by plotting on the one hand ${}_rK_1$ against \mathcal{K} and on the other ${}_rK_2$ against \mathcal{K} , in each case three curves are obtained and the point of intersection of these gave the value of \mathcal{K} which would result in a constant set of ${}_rK_1$ and ${}_rK_2$ values.

The ${}_rK_1$ set of curves was found to have a point of intersection at $\mathcal{K} = 19.06$ and this corresponds with an association constant ${}_rK_1 = 2.018$. The ${}_rK_2$ curves gave the intersection value of $\mathcal{K} = 19.10$ and the corresponding value of ${}_rK_2$ was 1.448. Values of degree of association in the mixture were calculated

Table 7. Association Constants for the Mixed Equilibria.

α	${}_1K_1$	${}_1K_2$	${}_2K_1$	${}_2K_2$	${}_3K_1$	${}_3K_2$
0	0	16.110	0	8.287	0	5.571
5	1.604	4.392	1.360	3.723	1.167	3.194
10	1.859	2.544	1.767	2.398	1.635	2.238
15	1.963	1.791	1.940	1.770	1.888	1.722
20	2.018	1.380	2.049	1.403	2.046	1.400
25	2.053	1.124	2.122	1.161	2.154	1.179
30	2.077	0.947	2.172	0.991	2.233	1.019
∞	2.208	0	2.468	0	2.733	0

and the final results are shown in Table 8.

Clearly therefore the system $\text{PBr}_3 + \text{Br}_2$ in nitrobenzene is completely described by considering the presence of both equilibria,

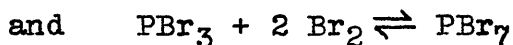
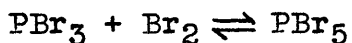

with the first of these predominating. The degree of association is relatively low or conversely it may be

Table 8. Results of Cryoscopic Study of the System, $\text{PBr}_3 - \text{Br}_2 - \text{C}_6\text{H}_5\text{NO}_2$.

Mole Ratio $\text{Br}_2:\text{PBr}_3$	Total Br_2 Concn.	PBr_5	PBr_7	$r\alpha_1 / r\alpha_2$
1:1	0.07306	$1\alpha_1 = 0.1134$	$1\alpha_2 = 0.005208$	$1\alpha_1 / 1\alpha_2 = 21.77$
2:1	0.1461	$2\alpha_1 = 0.2033$	$2\alpha_2 = 0.01875$	$2\alpha_1 / 2\alpha_2 = 10.84$
3:1	0.2192	$3\alpha_1 = 0.2709$	$3\alpha_2 = 0.03769$	$3\alpha_1 / 3\alpha_2 = 7.24$

For equilibrium, $\text{PBr}_3 + \text{Br}_2 \rightleftharpoons \text{PBr}_5$, $K(5.7^\circ\text{C}) = 2.018 \text{ mole}^{-1}\text{litre}$.

" " , $\text{PBr}_3 + 2 \text{ Br}_2 \rightleftharpoons \text{PBr}_7$, $K(5.7^\circ\text{C}) = 1.448 \text{ mole}^{-2}\text{litre}^2$.

said that the degree of molecular dissociation of phosphorus pentabromide in nitrobenzene is fairly high (ca. 90 %).

This result indicates that solutions of phosphorus pentabromide in nitrobenzene do contain PBr_5 entities and to a smaller extent some PBr_7 entities. The question of the structure of these units now arises, but cannot be answered with certainty. The PBr_5 unit could be either a trigonal bipyramidal molecule or it could be an ion pair.

The PBr_7 unit may be regarded as a complex formed between the PBr_5 entity and a bromine molecule through the latter donating a pair of its unbonded electrons to the phosphorus atom thus,

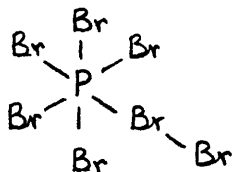

The phosphorus atom in this complex is seen to have the same electronic structure as the phosphorus atom in the PBr_6^- ion.

An ion pair formulation for the PBr_7 molecule is also possible ($[\text{PBr}_4^+][\text{Br}_3^-]$) but it is worth while remembering in this connection that $\text{PBr}_3 \cdot \text{Br}_4$ could not be recognised as an ionic complex in acetonitrile solution (page 14).

2. SOLUTIONS IN CARBON TETRACHLORIDE.

A cryoscopic investigation of the system phosphorus tribromide - bromine in carbon tetrachloride would be interesting as a means of verifying the findings of spectrophotometric studies of solutions of phosphorus pentabromide [17,18]. Cryoscopy in carbon tetrachloride has been reported twice in the literature [30, 31], and it is noted that the value of the cryoscopic constant given in these papers varies from 29.8 - 34.8 .

As a check on the experimental technique and in order that a new value of cryoscopic constant might be obtained, an experiment was carried out with nitrobenzene as solute. In this way the value of K_c was

found to be 32.37 , which lies mid-way between the extreme values found in the literature. It is noteworthy that very little supercooling (ca. 0.1 C°) was observed with this solvent.

When an attempt was made to study the phosphorus tribromide - bromine system it was found that at workable concentrations of the components, the complex $\text{PBr}_5 \cdot 2\text{CCl}_4$ crystallised from the solution before the freezing point of carbon tetrachloride was reached; thus invalidating the method for this study.

The saturation solubility of phosphorus pentabromide in carbon tetrachloride has been determined from 5 - 25 °C. and the following values of molality were found,

25°	2.614×10^{-2}
15°	2.285×10^{-2}
5°	1.625×10^{-2}

That is, the solubility falls quite rapidly with a drop in temperature. For a depression in freezing point of 1 C° (considering no dissociation of PBr_5) the solution would require a molality of 3.1×10^{-2} , at the freezing point, therefore it seems unlikely

that a sufficiently large depression would be obtained if the concentration used in the above experiment were made much lower.

... information about the ...
... If ...
... study of the vapour phase of ...
... it is ...

... values and ...
... vapour ...
... by a ...
... in Table 9. ...
... which it is ...
... portion of ...
... appearance of ...
... about 110 ...
... the ...

VAPOUR PHASE STUDY OF PHOSPHORUS PENTABROMIDE

Text-books on chemistry invariably state that the vapour of phosphorus pentabromide is formed with dissociation to bromine and phosphorus tribromide. A literature survey however reveals that vapour density measurements on phosphorus pentabromide have not previously been reported. Therefore there is no available information about the degree of dissociation at a given temperature. It was thought desirable to make a study of the vapour phase of phosphorus pentabromide in an attempt to acquire some information of its composition.

The pressure of a known volume and mass of phosphorus pentabromide vapour was measured over a range of temperatures by a static (spoon-guage) method, and the results of this are recorded in Table 9. These results are plotted in Fig. 8 from which it is seen that the commencement of the straight-line portion of the curve coincides with the observed disappearance of the last traces of liquid (at about 110 °C.). Thus it is possible to calculate the apparent molecular weight of the vapour at any temperature between 110° and 180°C.

Table 9. Vapour Pressure of Phosphorus Pentabromide.

Ascending Tmp. (°C)	Pressure (mm)	Descending Tmp. (°C)	Pressure (mm)
-180	0	163.0	149.40
61.0	30.45	153.0	146.43
76.0	75.85	134.5	139.93
99.0	121.93	125.5	136.76
113.0	132.48	112.0	132.33
128.0	137.46	100.0	128.26
139.5	141.59	85.5	107.04
151.0	145.58	70.0	75.03
160.0	148.67	19.2	0.75
171.0	152.33		
179.0	154.97		

This was done for several temperatures and the results obtained are shown in Table 10. From these it must be concluded that in the temperature range and pressure range studied dissociation is complete. In other words, the phosphorus pentabromide molecule does not exist in the vapour under these conditions. It would

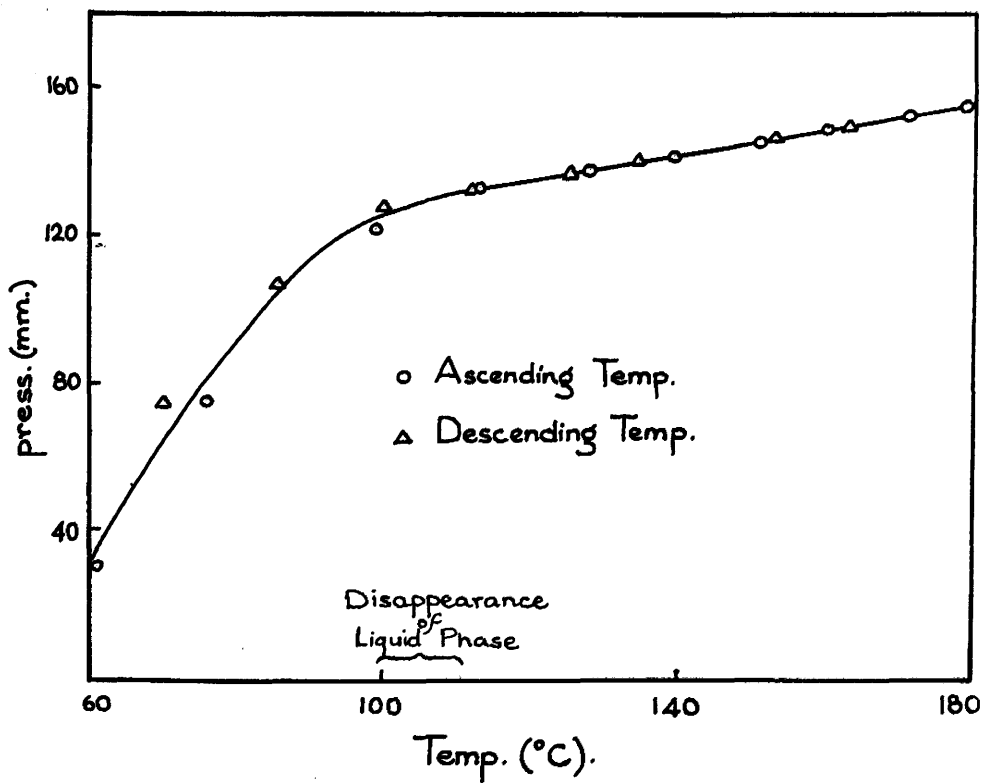

Fig. 8 Vapour Pressure of Phosphorus Pentabromide.

Table 10. Degree of Dissociation of Phosphorus Pentabromide in the Vapour.

Temp. (°C)	Observed M.W. (Theor. = 430.6)	Degree of Dissociation
110.0	215.11	100.16 %
150.0	215.02	100.24 %
180.0	215.71	99.60 %

be interesting to know the degree of dissociation of the vapour at lower temperatures and an experiment to measure this would be worth while doing.

The part of the graph up to 110 °C represents the vapour pressure of the dissociating compound. The pressures recorded are lower than those previously reported [9, 10] and for comparison all three sets of results are given in Fig. 9.

By extrapolation the apparent boiling point of phosphorus pentabromide is found to be 108 °C (previously accepted value = 106 °C.). The liquid phase was observed to appear at ca. 70 - 75 °C (previous

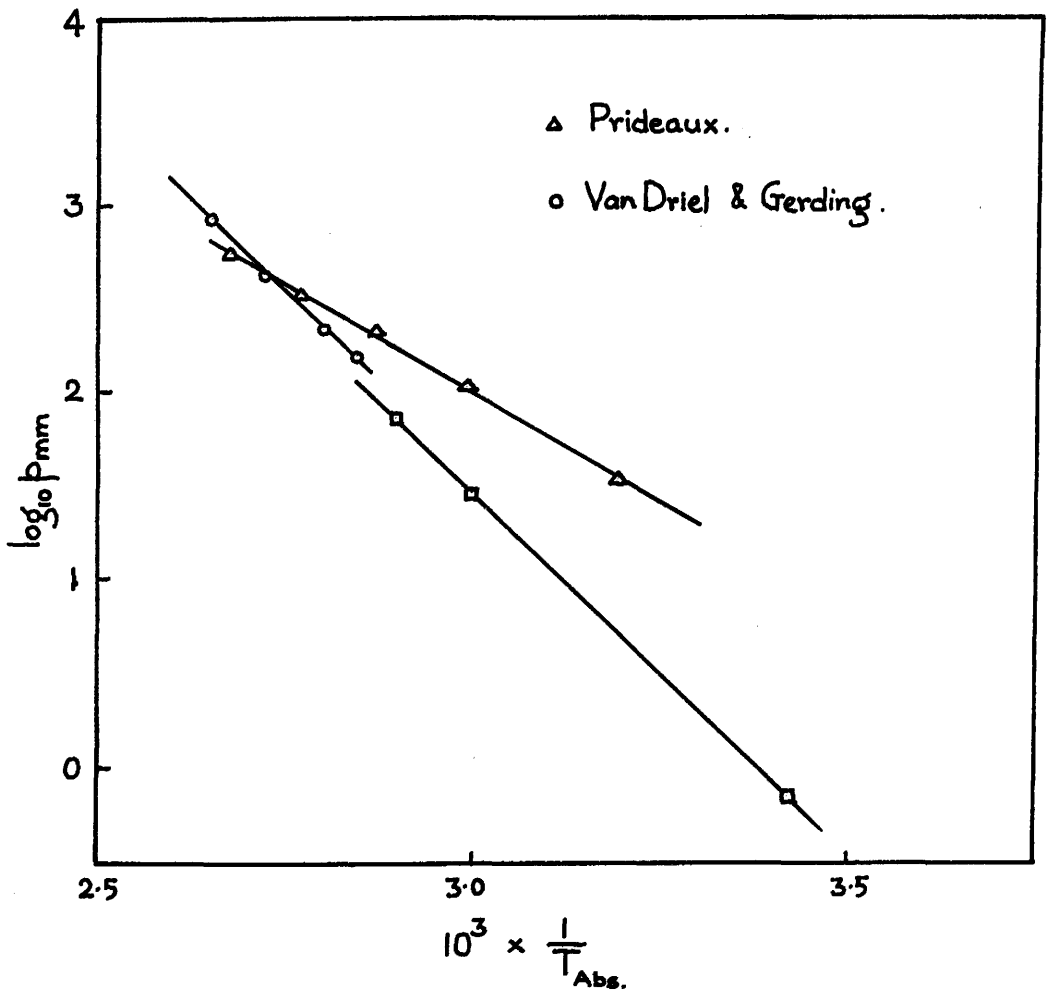

Fig. 9 Vapour Pressure Data on Phosphorus Pentabromide.

workers found that this occurred at about 85 °C.).

DISCUSSION

The most satisfactory results were obtained to be the product of 8.0%...
...with further addition of a...
...described by...
...material was left...
...pellets for...
...directly into...
... (10 - 20 mesh),...
...for a further...
...the liquid was then again...
...pentoxide. The...
...fresh...

EXPERIMENTAL PART

PURIFICATION OF MATERIALS

Solvents were in general purified by allowing the liquid to stand over a suitable desiccating agent and then distilling it. Acetonitrile, nitrobenzene, and carbon tetrachloride received special attention.

ACETONITRILE.

The most satisfactory starting material was found to be the product of B.D.H., Ltd. This material was further purified by a modification of the procedure described by Smith and Witten [32]. The crude material was left standing over AnalaR potassium hydroxide pellets for 7 days. It was then filtered and distilled directly into a flask containing calcium chloride (14 - 20 mesh), over which it was allowed to stand for a further period of several days. The liquid was then again filtered and distilled on to phosphorus pentoxide. The distillate was then redistilled on to fresh phosphorus pentoxide, and this procedure was repeated until the phosphorus pentoxide

in the receiving flask did not remain bound to the flask when the latter was swirled. At this stage too the distillate did not produce a yellow colour in the desiccant. The acetonitrile was then stored in a glass-stoppered flask over the phosphorus pentoxide until it was required for use. The acetonitrile was then distilled from the storage flask, and the distillate (which was very slightly cloudy) was distilled in vacuo from ca. 0°C to -183 °C. This removed traces of phosphorus pentoxide which otherwise sublimed over during distillation from the desiccating agent at ordinary pressures.

b.p. = 81 - 82 °C (760mm) ; $n_D^{21} = 1.3431$

$\kappa = \text{ca. } 10^{-7} \text{ ohm}^{-1}\text{cm}^{-1}$ at 25 °C.

(impure material, $\kappa = 3.5 \times 10^{-5} \text{ ohm}^{-1}\text{cm}^{-1}$)

NITROBENZENE.

The preparation of pure nitrobenzene for conductance measurements has been described by Kraus and Taylor [33]. Commercial nitrobenzene (Hopkin and Williams) was washed with aqueous sulphuric acid (1 acid : 2 water) and then with water.

This was followed by washing with saturated caustic soda solution till the aqueous layer was colourless and finally the material was washed with water until neutral to litmus. The nitrobenzene was allowed to stand over 14 - 20 mesh calcium chloride for several days. After filtration it was distilled at ordinary pressure. The first fraction (azeotrope with water) was discarded and the fraction which boiled at 206 - 208 °C. was taken. The nitrobenzene was then fractionally frozen once, and the unfrozen liquid amounting to a quarter of the total volume was poured off. The liquid was then distilled under reduced pressure (ca. 2 mm.). The first and last portions were rejected and the fraction distilling between 64 - 68 °C. was taken.

$$\kappa = 2 \times 10^{-7} \text{ ohm}^{-1} \text{ cm}^{-1} \text{ at } 25 \text{ }^\circ\text{C.}$$

CARBON TETRACHLORIDE.

The method used to obtain pure carbon tetrachloride was a variation of that described by Popov and Schmorrr [17]. Carbon tetrachloride (H. and W.) (500 cc.) was refluxed for 10 hours with a

saturated solution of potassium permanganate in 2 N sodium hydroxide solution (100 cc.). The carbon tetrachloride was then separated and washed several times with water. The material was submitted to a preliminary drying by anhydrous magnesium sulphate, and was then filtered and distilled on to phosphorus pentoxide, and the carbon tetrachloride was distilled several times from the drying agent on to fresh phosphorus pentoxide.

b.p. = 75.8 - 76.0 °C. (760 mm.)

PHOSPHORUS PENTABROMIDE.

Recrystallisation of commercial phosphorus pentabromide (B.D.H.) was the method adopted (compare the method used by Van Driel and Gerding [10]). The crude material (10 g.) was dissolved in pure nitrobenzene (50 cc.) at 60 °C. A fine white residue remained and this was removed by filtering the solution through a sintered glass filter (of special design to enable the operation to be carried out under anhydrous conditions). The solution was cooled and the phosphorus pentabromide came out of

solution as fine yellow crystals, which were separated by filtration. The crystals were washed with sodium dried ether (100 cc.) and stored in a ground glass stoppered tube kept in a desiccator. Analysis revealed that the product was pure phosphorus pentabromide.

PHOSPHORUS TRIBROMIDE.

The crude liquid (B.D.H.) which was pale yellow in colour was distilled using a short column at ordinary pressure, yielding a colourless, slightly turbid product (b.p., 172 - 173 °C.). The compound was then fractionated in vacuo as follows. The liquid was transferred in flask A to a fractionation line of the vacuum system (Fig. 10) which was evacuated as far as tap T_1 . The phosphorus tribromide in flask A was cooled to -183 °C. (liquid oxygen) and then tap T_1 was opened. The phosphorus tribromide was then degassed before fractionation by closing tap T_1 , allowing the solid to melt, refreezing and pumping off again through tap T_1 . This was repeated

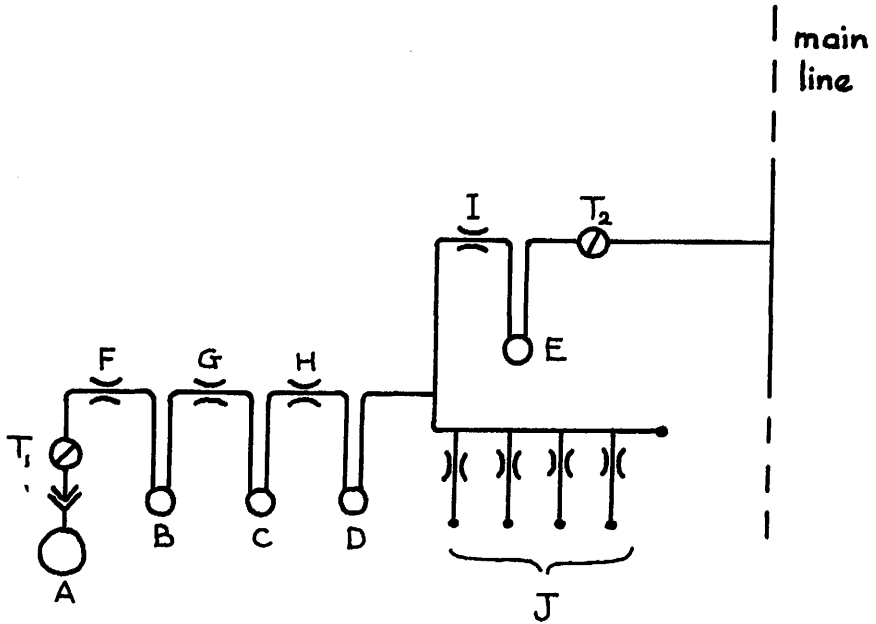

Fig. 10. Vacuum Fractionation of Phosphorus Tribromide.

twice, after which the phosphorus tribromide was ready for fractionation. Tap T_2 was closed and tap T_1 opened and the phosphorus tribromide was made to distil from flask A into trap B by cooling the latter to $-183\text{ }^\circ\text{C}$. When the trap was filled, tap T_1 was closed and constriction F was sealed off. The phosphorus tribromide in trap B was allowed to warm up and then about four-fifths of its bulk was distilled into trap C. Constriction G was then sealed. This distillation was repeated from trap C to trap D. Thus in each case the residual less volatile fraction was rejected by sealing off the trap containing it. In order to remove the more volatile impurities in the phosphorus tribromide, such as hydrogen bromide, about one quarter of the material in trap D was distilled into trap E and then constriction I was sealed.

The purified phosphorus tribromide remaining in trap D was then distilled into the tube-ampoules J which were sealed off. The final product was a clear, colourless, refractive liquid, and it was stored in the ampoules until required for use.

BROMINE.

AnalaR bromine (B.D.H.) was placed in a small flask attached to the vacuum system and pumped off to remove the more volatile impurities. The bromine was then cooled to 0 °C and distilled in vacuo into ampoules cooled to -85 °C (acetone - Drikold mixture). These ampoules were sealed off and the bromine stored thus.

PHOSPHORUS OXYBROMIDE. [34]

This compound was prepared by heating an intimate mixture of finely divided phosphorus pentoxide (12 g.) and phosphorus pentabromide (100 g.) very gently and slowly on a water bath till the mass completely liquefied (2 hours). The temperature was then raised slowly over 1 hour and finally the phosphorus oxybromide was allowed to distil over at atmospheric pressure. The middle fraction (b.p., 194 °C) was collected. The material obtained was a white crystalline solid, and this was carefully protected from atmospheric moisture.

STANNIC BROMIDE.

Stannic bromide was prepared by dropping a solution of bromine (70 g.) in carbon disulphide (50 g.) on to metallic tin (24 g.). The resulting solution was fractionally distilled at atmospheric pressure and the stannic bromide was collected at 200 °C. It was a white solid and was stored in a glass stoppered bottle.

PREPARATION OF WEIGHED SAMPLES OF LIQUIDS.

In the work leading to this part and the other two parts of the thesis it was often necessary to add a known weight of a liquid compound to a system. It was found that the most convenient way of doing this was to introduce the known weight of material enclosed in a bulb-ampoule, and then to break this bulb.

The unfilled bulb, whose open end terminated in a B 7 cone, was initially weighed. It was then attached to the vacuum system by means of the joint, filled by

distillation, and finally sealed off at the narrow neck. The detached cone was then carefully freed from tap-grease and weighed along with the bulb plus its contents.

The material used to fill the bulb was invariably obtained from a storage ampoule (tube type) which was broken in a standard breaker attached to the system.

CONDUCTOMETRIC TITRATIONS.

The apparatus used in this method of analysis is described in Appendix 3 where the procedure is given in some detail. The concentrations of the solutions used were carefully pre-arranged so that the desired range of mole ratio would be covered. Solutions of bromine and phosphorus tribromide in acetonitrile were prepared by the breaking of weighed ampoules in known amounts of the solvent. Solid solutes were weighed out by difference in the normal manner. In the phosphorus tribromide -

bromine system, the bromine solution was the titrant; and in the phosphorus pentabromide - stannic bromide system the pentabromide solution was employed as titrant.

MEASUREMENT OF CONDUCTANCE.

The conductance cell, which was of the pipette type, was incorporated in the vacuum system, and the essential features are shown in Fig. 11. The solute (about the correct quantity) was transferred to tube A, either by direct addition or by distillation in the case of volatile compounds. The solvent, initially contained in flask B was then allowed to distil into tube A by surrounding the latter with a suitable coolant (usually liquid oxygen). To achieve mixing after the solvent had melted, dry air was bubbled through the solution; pressure differences being arranged by careful adjustment of taps T_1 and T_2 . The cell was then filled by the application of suitable pressure differences. The electrode chamber was then surrounded by a water

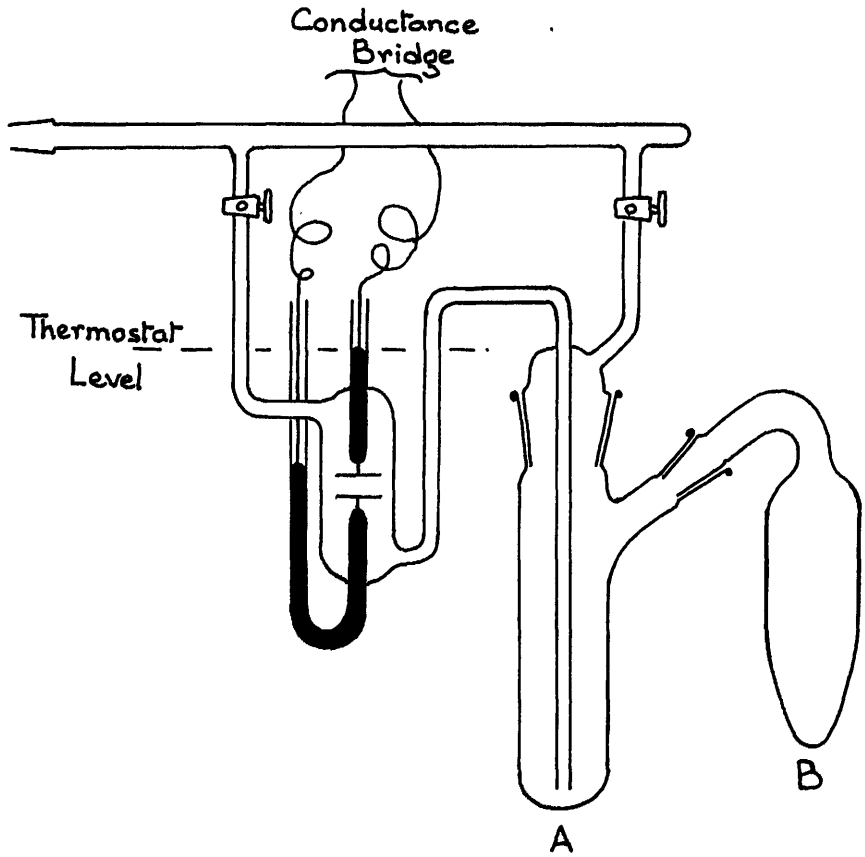

Fig. 11. Conductance Cell.

thermostat bath at 25 °C and conductance measurements were begun. This was done using a Mullard Conductance Bridge (Type E 7566). The electrodes of the cell were made of smooth platinum each 1 cm² in area and the cell constant was 0.500 cm⁻¹ (found using standard potassium chloride solutions [35]).

The concentrations of the solutions were determined by chemical analysis. After the measurement of conductance, the solution was returned to tube A, and from this measured samples of the solution were taken. These were hydrolysed by dilute sodium hydroxide solution and the resulting solutions were analysed in the appropriate way (invariably by estimation of halide ion content by Volhard's method).

ELECTROLYSIS EXPERIMENTS.

The electrolysis cell used in these experiments is described in Appendix 4. Results were considered valid only if the middle solution varied negligibly in concentration after the experi-

ment from the concentration of the original solution. Methods of determining the bromine and phosphorus content of the various solutions were the general ones described in the section entitled "Methods of Analysis".

ABSORPTION SPECTRA.

Absorption spectra were measured using a Unicam Ultraviolet Spectrophotometer. The solutions were contained in 1 cm. quartz cells with ground glass joints. These solutions were prepared by a procedure similar to that used in the conductance experiments, and the solutions were transferred to the cells by a simple pressure difference technique. Measurements were made at 20 °C.

CRYOSCOPY.

The cryoscopic cell and its use is described in Appendix 5. When nitrobenzene was used as solvent the cooling agent was a water - ice mixture at 0.5 °C. In the case of the experiment done with carbon tetra-

chloride (f.p., -22.8°C) as solvent, the coolant was acetone maintained at about -30°C by adding to it small pieces of 'Drikold'.

After the freezing point of the pure solvent had been found, phosphorus tribromide was introduced and the freezing point redetermined. Bromine was then added in stages and the freezing point of the solution determined after each addition.

VAPOUR DENSITY MEASUREMENT.

The determination of the vapour density (or apparent molecular weight of vapour) of phosphorus pentabromide was done by a constant volume method and the apparatus is shown diagrammatically in Fig. 12. The following is a description of the method.

Pressure Measurement.

The spoon guage in this system was used as a null instrument in which the deflection of the pointer was magnified by the optical lever principle. The point-

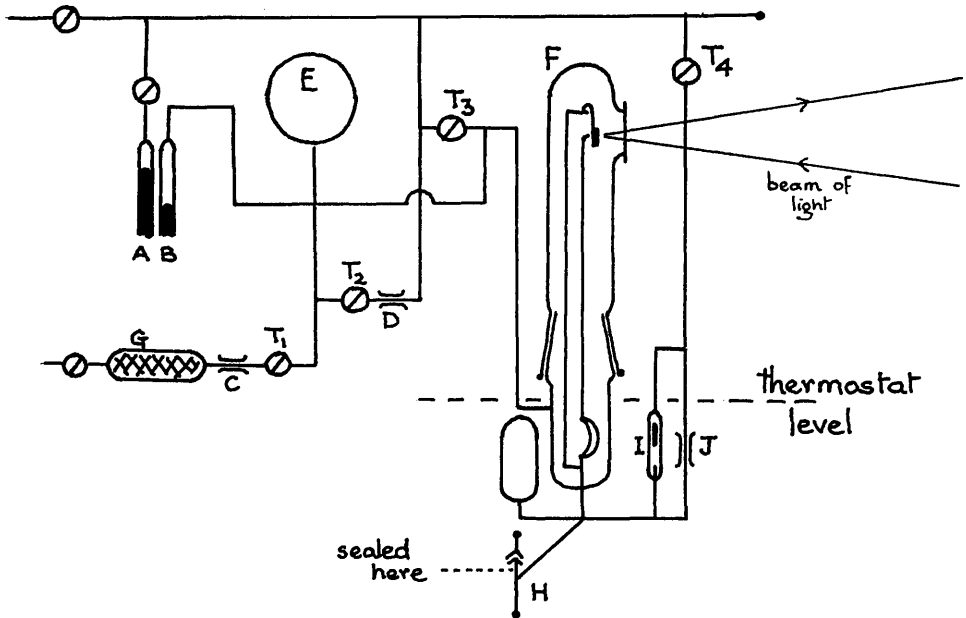

Fig. 12. Vapour Density Apparatus.

er of the guage was made to actuate a small delicately balanced mirror which reflected a parallel beam of light on to a scale situated at a distance of 1 metre. A pressure differential of 0.1 mm. of mercury across the guage resulted in the beam of light being deflected 20 mm. at the scale. The zero point of the instrument could therefore be determined with high accuracy.

The vapour pressure of the compound being investigated was compensated by admitting dry air from vessel G through tap T_1 to the chamber F. High sensitivity of this adjustment was afforded by the capillary leak C and the air-surge chamber E. When it was necessary to reduce the pressure in this part of the apparatus, the section was connected to the vacuum line via tap T_2 and the fine constriction D. Thus when the pressures on either side of the diaphragm had been equilibrated, the pressure could be obtained from the wide bore (10 mm.) mercury manometers A and B which were arranged close to one another and which used a common mercury reservoir. Manometer A was employed as an ordinary barometer and the difference in the levels of mercury in A and B (read by means of an accurate

(0.01 mm.) cathetometer) was therefore the pressure of the gas above the mercury in B.

Temperature Control.

Use was made of a paraffin oil thermostat which was heated by two 500 watt immersion heaters. Temperature control was effected using a Sunvic Thermo-regulator (Type TS 2 NC) and Relay (Type F 102/3).

In measuring the vapour density of phosphorus pentabromide, the compound was weighed out in a small tube with a ground glass stopper (B 7) and this was then placed inside tube H of the vapour density apparatus. The lower part of this tube was surrounded by liquid oxygen, whilst the upper part was removed by sealing at the point shown in the diagram. With taps T_3 and T_4 opened, the system was evacuated for an hour and following this constriction J was sealed off. The phosphorus pentabromide was thus contained in an all glass system (capacity about 150 cc.) and the measurement of pressure variation with temperature

was the next stage in the experiment.

The constant volume part of the apparatus was surrounded by the thermostat bath up to the level indicated. The temperature was then raised in stages (giving the system time to attain equilibrium at each stage) and the corresponding pressures noted. After the maximum temperature had been reached, a series of pressure measurements was made for descending temperature steps. At room temperature, seal I was broken magnetically, taking care that in doing so, no pressure differential across the guage would result. The phosphorus pentabromide was then removed from the system by pumping.

Finally the capacity of the system (i.e. the 'constant volume') was determined by dismantling the apparatus at convenient places and filling it with water of which the volume could easily be determined. This was found to yield a more reliable result than the usual method of expanding a gas within the system.

X-RAY POWDER PHOTOGRAPHY.

The series of photographs was taken using a 'Unicam' 19 inch powder camera. Specimens were mounted in sealed capillary tubes (Pyrex glass). Very fast, high contrast film (Ilford-Industrial G) was used. The radiation used was CuK_{α} and the average exposure of each film was five hours.

METHODS OF ANALYSIS.

(a) Solid Phosphorus Pentabromide.

A known weight of the material was hydrolysed by dilute (2N) sodium hydroxide solution. This solution was made up in a standard flask, and aliquot portions of the resulting solution were analysed for bromide ion and phosphate ion. The bromide ion content was determined by Volhard's method, and the phosphate ion was precipitated as magnesium ammonium phosphate which was ignited and weighed as magnesium pyrophosphate.

(b) Solutions of Phosphorus Pentabromide.

The solutions were first of all hydrolysed by boiling with dilute sodium hydroxide solution, and the bromide and phosphate ions were then estimated in the usual way.

The validity of this procedure in the case of acetonitrile solutions was checked using a standard solution of phosphorus pentabromide in acetonitrile. The results obtained were,

By analysis, wt. of Br in 100cc. of solution = 0.845 g.
By weight, " " " " " = 0.850 g.

ANALYSIS OF THE
SYSTEM PHOSPHORUS TRICHLORIDE
- BROMINE

PHOSPHORUS TRICHLORIDE AS SOLVENT
IN THE SYSTEM PHOSPHORUS TRICHLORIDE
- BROMINE

P A R T II

THE SYSTEM PHOSPHORUS TRICHLORIDE - BROMINE

1. Introduction

2. Experimental

3. Results and Discussion

4. Conclusions

I N D E X

	Page
INTRODUCTION	81 - 92
RESULTS AND DISCUSSION	93 - 118
1. Conductometric Analysis of the System Phosphorus Trichloride - Bromine in Various Solvents.	93
(a) Acetonitrile as Solvent.	93
(b) Nitrobenzene as Solvent.	96
(c) Phosphorus Oxychloride as Solvent.	99
2. Cryoscopic Study of the System Phosphorus Trichloride - Bromine - Nitrobenzene.	104
3. Attempts to Prepare an Adduct of Phosphorus Trichloride and Bromine.	111
(a) Survey of Suitable Solvents.	111
(b) Results of Analyses.	114
EXPERIMENTAL PART	119 - 127
1. Purification of Materials.	119
(a) Phosphorus Trichloride.	119
(b) Phosphorus Oxychloride.	119
(c) 1:4-Dioxan.	120
(d) Ethylene Dichloride.	120
2. Conductometric Analyses.	121
3. Depression of Freezing Point Experiment.	121

	Page
4. Adduct of Phosphorus Trichloride and Bromine.	122
(a) Preparation.	122
(b) Analysis.	122
5. Preparation of PCl_3Br_4 as described by Fialkov and Kuz'menko.	125

INTRODUCTION

Studies on the reaction between bromine and phosphorus trichloride fall historically into three periods during which attempts have been made to isolate or recognise the existence of bromide chlorides of phosphorus. The work done during the first two periods (1847 - 1886 and 1928 - 1934) had as its main object the synthesis of compounds from the phosphorus trichloride - bromine system, and consequently the literature contains many preparative and analytical descriptions. Data on the substances obtained is scant and is limited to a few physical characteristics (e.g. melting points and shape and colour of crystals) and some solvolytic chemical reactions, but no light is shed on their chemical nature. The third period (1951 - present) is one in which the phosphorus trichloride - bromine system has been the subject of investigation by the methods of physical chemistry, with the object of identifying the stable units in the system and obtaining knowledge of their chemical type.

1st Period.

The first mention in the literature of the existence of a phosphorus bromide chloride is in a paper by Wurtz [36] who claims that he had prepared the compound PCl_3Br_2 . However in this paper there are no preparative or analytical details.

Gladstone [37] studied the reaction between phosphorus trichloride and bromine in an attempt to prepare PCl_3Br_2 but his efforts were unsuccessful.

Later, Wichelhaus [38] reported that he had synthesised PCl_3Br_2 by cooling an equimolar mixture of phosphorus trichloride and bromine in a freezing mixture. No analytical data are given and Wichelhaus says that the reaction goes in reverse when the solid is melted.

A more thorough investigation of the phosphorus trichloride - bromine system was carried out by Prinvault [39, 40] who, like Gladstone, was unable to isolate a compound of formula PCl_3Br_2 . Prinvault added bromine to phosphorus trichloride and heated the resultant homogeneous liquid on a water-bath till no

more bromine was evolved and in this way he obtained a red liquid which crystallised at -4 to -5 °C into brown oily needles. The composition of this material was found to correspond with the formula PCl_3Br_8 and it is stated that this compound has a colourless vapour. Another compound PCl_3Br_4 was obtained by the reaction between PCl_3Br_8 and phosphorus trichloride. Prinvault puts forward the claim that he isolated two other bromide chlorides of phosphorus of formulae PCl_2Br_7 and PCl_4Br . He suggests that the PCl_3Br_8 and PCl_2Br_7 should be written as addition compounds of phosphorus pentabromide with bromine chloride :

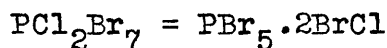
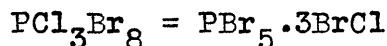

Michaelis [41] repeated Wichelhaus's experiment on the attempted preparation of PCl_3Br_2 with the same results ; but he found that if the mixture of phosphorus trichloride and bromine was kept for a week in a sealed tube at low temperature, a yellow crystalline solid (resembling PBr_5) was obtained which did not

separate into two layers on liquefaction. Analysis of the material did not yield a definite result but Michaelis says that the material is PCl_3Br_2 + 5.2 % phosphorus trichloride.

In another experiment, Michaelis [42] took the lower liquid layer which is formed on mixing phosphorus trichloride and bromine, and he seeded this with a crystal of his PCl_3Br_2 . In this way he obtained dark red crystals with a blue tinge, and this material analysed for PCl_3Br_4 . A compound of formula PCl_3Br_8 was also obtained by adding a large excess of bromine to phosphorus trichloride. This compound which formed brown needles had a melting point of 25 °C, in contrast with Prinvault's preparation which melted at -4 °C.

Prinvault's formulation of some of these compounds as addition products of phosphorus pentabromide and bromine chloride is criticised by Michaelis who found that their reaction with sulphur dioxide did not as would be expected yield phosphorus oxybromide and bromine chloride. Michaelis found that the compounds behaved as a mixture of PCl_3Br_2 and bromine and he

suggests that the compounds are of the general type $\text{PCl}_3\text{Br}_2 \cdot x\text{Br}_2$. Thus they would appear to be members of a group of molecular addition compounds of PCl_3Br_2 :-

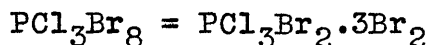
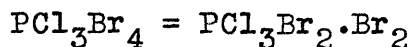

This is compared with the series of addition compounds having phosphorus pentachloride as the parent,

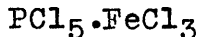
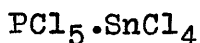
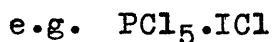

This idea has however been criticised by Geuther [43] who says that it is based on the compounds reacting with sulphur dioxide to yield phosphorus oxychloride, sulphur tetrabromide, and bromine, but no phosphorus oxybromide. Michaelis' argument assumes that phosphorus oxybromide and bromine chloride do not interact with the formation of phosphorus oxychloride whereas in fact Geuther has found that such a reaction does occur; thus rendering Michaelis' results inconclusive.

Stern [44] thought that a more complete investigation of the reaction between bromine and phosphorus trichloride was essential and to this end he carried out experiments on this system, analysing the products at each stage. He obtained results which suggested that the following sequence of reactions occurred. Equimolar amounts of phosphorus trichloride and bromine resulted in the formation of PCl_3Br_2 and the addition of a further mole of bromine brought about the replacement of one chlorine atom by a bromine atom giving PCl_2Br_3 . A further mole of bromine can then be added on to give PCl_2Br_5 . Stern says that this compound could add on more bromine at low temperatures, and he makes the general statement that the lower the temperature then the greater the number of halogen atoms with which phosphorus can combine.

2nd Period.

The subject of bromide chlorides of phosphorus was taken up again about twenty years later by Milobedski and Krakowiecki [45, 46] who found that the phosphorus trichloride - bromine system yielded a

yellow crystalline compound of formula PCl_4Br , but they were unable to prepare the compound PCl_3Br_2 . They have found that bromine vapour reacts with the vapour of phosphorus trichloride to produce a number of crystalline phases of general types PCl_2Br_n , PCl_3Br_n in which $n = 2 - 10$. The parent compounds in these series are regarded as PCl_2Br and PCl_4Br . For example they suggest that,

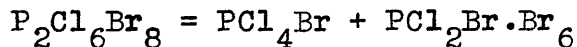
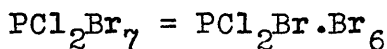

The same authors [47] carried out an extensive series of experiments in which mixtures of phosphorus trichloride and bromine were prepared in various proportions from $\text{PCl}_3 : 0.0833\text{Br}$ to $\text{PCl}_3 : 20\text{Br}$, and they came to the conclusion that four phases were formed at 25 °C, namely,

- (a) a yellow crystalline phase of limiting composition PCl_4Br .
- (b) a red crystalline phase PCl_2Br_5 .

- (c) a light -red liquid phase whose composition varied within the limits $\text{PCl}_{2.952}\text{Br}_{0.154}$ to $\text{PCl}_{2.795}\text{Br}_{0.461}$
- (d) a brown-red liquid phase with a composition ranging from $\text{PCl}_{3.439}\text{Br}_{4.677}$ to $\text{PCl}_3\text{Br}_{20}$.

Milobedski and Krakowiecki found that the crystalline mixtures on evaporation yielded yellow crystals, therefore they regarded the mixtures not as simple addition products of phosphorus trichloride and bromine but as solid mixtures composed probably of PCl_4Br , PCl_2Br_5 , and bromine, thus,

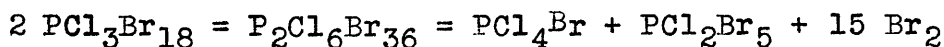
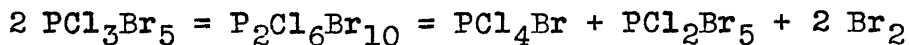

A short time later the phosphorus trichloride - bromine system was studied by Renc [48] whose conclusions were essentially similar to those of Milobedski and Krakowiecki. Renc found that at 135 °C PCl_4Br was converted into a crystalline phase, $\text{PCl}_{4.5}\text{Br}_{0.5}$, a deep-red liquid, $\text{PCl}_{3.4}\text{Br}_{3.6}$, and a light-red liquid $\text{PCl}_{2.87}\text{Br}_{0.27}$. Much work was done

by Renc [49, 50, 51] in an endeavour to prepare phosphorus bromide chlorides starting from phosphorus penta- or tri- bromide and penta- or tri- chloride. He heated these compounds together in a sealed tube at 135 °C and obtained mixtures of variable composition similar to those obtained in the direct reaction of bromine and phosphorus trichloride. The same products were obtained when the mixtures were made in carbon disulphide solution. In this way Renc obtained a crystalline substance of approximate composition PClBr_4 .

The relative proportion of bromine and chlorine present in the initially formed bromide chloride is reported to change slightly when the environment is changed. For example crystals with more than three atoms of chlorine per atom of phosphorus lose bromine under reduced pressure yielding products of limiting composition PCl_4Br . Similarly recrystallisation of these compounds from carbon disulphide results in a change of composition of the solid phase in such a way that the crystals obtained contain more of the

halogen which was originally present in greater abundance. This type of behaviour has been met with in the work on triphenoxyphosphorus dihalides which is described in Part III of the thesis.

3rd Period.

A physico-chemical approach to the study of the phosphorus trichloride - bromine system has recently been initiated simultaneously by Fialkov and his co-workers in Russia and Payne and his co-workers in Glasgow. Part II of this thesis is the author's contribution to the findings of the latter school.

Fialkov and Kuz'menko [52] made a thermal analysis of the phosphorus trichloride - bromine system, and the diagram they obtained contained two maxima at compositions corresponding to PCl_3Br_4 and $\text{PCl}_3\text{Br}_{18}$; and methods are described for the preparation of solids having these formulae. They found that these compounds are good conductors of electricity in the liquid state (PCl_3Br_4 has $\kappa = 1.82 \times 10^{-4}$ at 35°C ; $\text{PCl}_3\text{Br}_{18}$

has $\kappa = 8.01 \times 10^{-2}$ at 25 °C), but only $\text{PCl}_3\text{Br}_{18}$ conducts in the solid state ($\kappa = 1.53 \times 10^{-3}$ at 20 °C.). Viscosity measurements on the system [53] indicate the existence of yet another compound PCl_3Br_8 .

Fialkov and Kuz'menko have studied the specific conductances of these three compounds in nitrobenzene solution and have found that it increases in the order $\text{PCl}_3\text{Br}_4 < \text{PCl}_3\text{Br}_8 < \text{PCl}_3\text{Br}_{18}$, ($\kappa \approx 10^{-2} \text{ ohm}^{-1}\text{cm}^{-1}$). As a result of transport experiments they suggest that the compounds have a halogenophosphonium polyhalide type of structure $[\text{PCl}_3\text{Br}][\text{Br}(\text{Br}_2)_n]$. The reaction between phosphorus trichloride and bromine is therefore considered to take the course -



The higher conductances noted when the bromine content is increased is attributed to a shifting to the left of the thermal dissociation equilibrium -

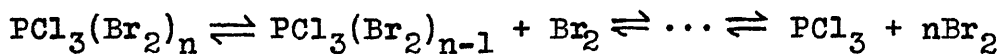

resulting in an enhancement of ionisable species.

In their investigation of the conductances of the various complexes in nitrobenzene, Fialkov and Kuz'menko have made use of concentrations much higher than those normally encountered in studies of electrolytic conductance. Their conductance measurements in fact cover a range of concentrations from 0.4M to 50M. Values of concentration used in the present work are however similar to those used in previous studies of phosphorus halides [23, This thesis parts I and III], that is from 0.01 M to 0.1 M.

As well as recognising the need for physico-chemical analysis of the systems phosphorus trichloride - bromine - solvent, it was thought desirable to attempt the preparation of phosphorus bromide chlorides, since much of the data found in the literature and especially in the earlier papers seem to be rather doubtful and at times contradictory.

RESULTS AND DISCUSSION

CONDUCTOMETRIC ANALYSIS OF THE SYSTEM PHOSPHORUS
TRICHLORIDE - BROMINE IN VARIOUS SOLVENTS.

This series of experiments was carried out in order to investigate the possible existence in solution of ionic complexes formed from phosphorus trichloride and bromine. If these compounds interact rapidly to produce ionic species then the process should be reflected in the shape of the specific conductance - mole ratio graph.

Acetonitrile as Solvent.

The addition of bromine to phosphorus trichloride in acetonitrile solution was found to produce a marked increase in the conductance of the latter solution, but it was found that the conductance of the mixture did not attain a stationary value within a short time. A 1:1 mixture of phosphorus trichloride and bromine in acetonitrile was prepared and its conductance noted at intervals,

and in this way a variation in conductance with time as shown in Fig. 13 was obtained. This clearly indicates that the system $\text{PCl}_3 - \text{Br}_2 - \text{CH}_3\text{CN}$ is not amenable to conductometric analysis.

Parallel with the conductance drift, a change in the colour of the solution was observed ; originally the solution had a deep orange colour and this gradually diminished to a pale yellow colour. Thus it is quite obvious that some fundamental change is taking place in the system and this may be simply reaction between the phosphorus trichloride and bromine or reaction between one or both of these compounds and the acetonitrile. To elucidate this point, a yellow solution of phosphorus trichloride and bromine in acetonitrile was cooled to $-30\text{ }^\circ\text{C}$ and the solvent removed under vacuum. In this way a gelatinous yellow residue was obtained and this material was found to contain nitrogen (abundantly), phosphorus, chlorine, and bromine. This strongly suggests that chemical reaction involving the solvent occurred and hence acetonitrile must be regarded as an unsuitable solvent for the present study.

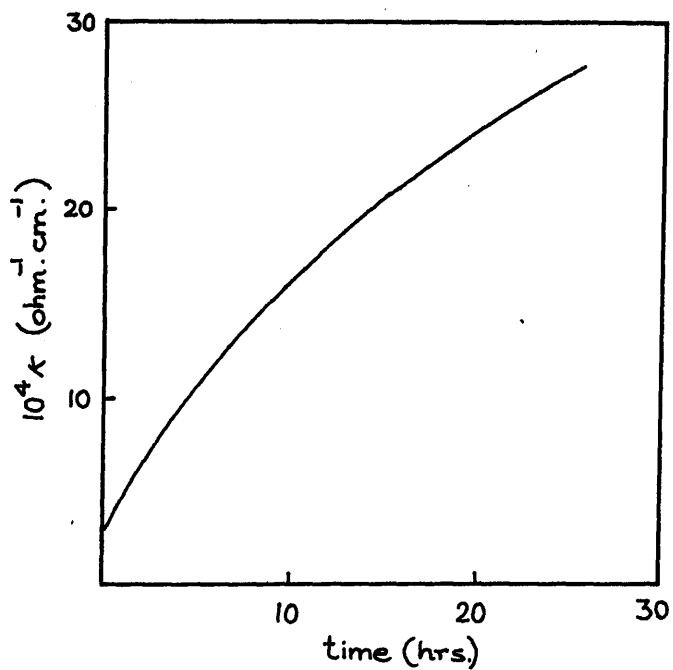

Fig. 13. Conductance of $\text{PCl}_3 + \text{Br}_2$ in Acetonitrile.

Nitrobenzene as Solvent.

The molar conductances of solutions of phosphorus trichloride and bromine in nitrobenzene are low,

$$\text{PCl}_3 ; \Lambda_m = 0.0099 \text{ ohm}^{-1} \text{ cm}^2 \text{ mole}^{-1} \quad \text{at } c_m = 0.01837$$

$$\text{Br}_2 ; \Lambda_m = 0.056 \quad " \quad " \quad " \quad . \quad \text{at } c_m = 0.03608$$

[The conductance of the phosphorus trichloride solution was steady, but that of the bromine solution rose very slightly with time ($0.77 \times 10^{-6} \text{ ohm}^{-1} \text{ cm}^{-1}$ per hour)]

The titration of one solution by the other resulted in an increase in specific conductance as shown in Table 11 and Fig. 14. The conductance values at each stage in the titration attained a steady value.

It is seen that the graph has two rather poorly defined inflections at compositions corresponding to PCl_3Br_8 , and approximately PCl_3Br_4 , and the molar conductances calculated for the solution at these mole ratios are :-

Table 11. Conductometric Analysis of the System
PCl₃ - Br₂ in nitrobenzene.

Mole Ratio Br ₂ :PCl ₃	10 ⁶ κ ohm. ⁻¹ cm. ⁻¹	Mole Ratio Br ₂ :PCl ₃	10 ⁶ κ ohm. ⁻¹ cm. ⁻¹
0.00	0.24	2.99	4.86
0.18	1.07	3.34	5.22
0.52	1.36	3.68	5.57
0.87	1.75	3.85	5.77
1.22	2.27	4.19	6.03
1.58	2.79	4.54	6.22
1.94	3.43	4.89	6.45
2.29	4.02	5.24	6.61
2.64	4.54		

PCl₃Br₄ ; $\Lambda_m = 0.21 \text{ ohm.}^{-1} \text{ cm.}^2 \text{ mole.}^{-1}$ at $c_m = 0.01642$

PCl₃Br₈ ; $\Lambda_m = 0.33$ " " " . at $c_m = 0.01483$

It is interesting to note that phosphorus pentachloride in nitrobenzene has a molar conductance of about ten times these values at similar concentrations

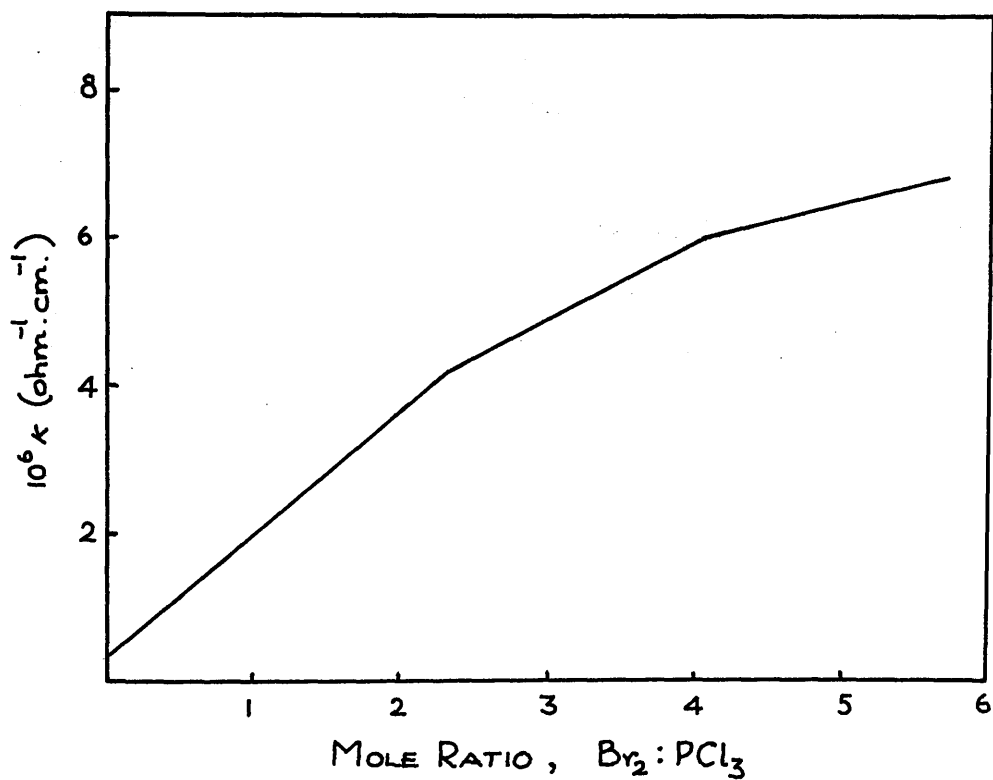

Fig. 14. Conductometric Analysis of the System
PCl₃ - Br₂ - nitrobenzene.

[23]. The increase in specific conductance with increasing mole ratio of bromine to phosphorus tribromide is in agreement with the observations of Fialkov and Kuz'menko [53].

Phosphorus Oxychloride as Solvent.

Conductometric titration of phosphorus trichloride with bromine in phosphorus oxychloride solution gave the results shown in Table 12 and Fig. 15. Molar conductance values of the separate components in phosphorus oxychloride were found to be :

$$\text{PCl}_3 : \Lambda_m = 0.023 \text{ ohm}^{-1} \text{ cm}^2 \text{ mole}^{-1} \text{ at } c_m = 0.0244$$

$$\text{Br}_2 : \Lambda_m = 0.013 \quad " \quad " \quad " \quad . \text{ at } c_m = 0.0325$$

With this solvent as with nitrobenzene, the conductance of the solution was quite stable after each addition of titrant. Addition of bromine to the phosphorus trichloride solution produces only a very slight rise in conductance of the latter, but by drawing the graph with a large specific conductance

Table 12. Conductometric Analysis of the System

PCl₃ - Br₂ in phosphorus oxychloride.

Mole Ratio Br ₂ :PCl ₃	10 ⁶ κ ohm. ⁻¹ cm. ⁻¹	Mole Ratio Br ₂ :PCl ₃	10 ⁶ κ ohm. ⁻¹ cm. ⁻¹
0.00	0.227	2.44	0.570
0.30	0.298	2.75	0.635
0.60	0.356	3.04	0.642
0.91	0.411	3.33	0.680
1.21	0.454	3.63	0.710
1.52	0.496	3.93	0.739
1.98	0.557	4.39	0.774
2.14	0.570		

scale the curve is seen to have two weak inflections at the ratios 1 and 2 corresponding to PCl₃Br₂ and PCl₃Br₄. The corresponding molar conductances at these ratios are :-

PCl₃Br₂ ; $\Lambda_m = 0.031 \text{ ohm}^{-1}\text{cm}^2 \text{ mole}^{-1}$, $c_m = 0.0137$

PCl₃Br₄ ; $\Lambda_m = 0.046$ " " " , $c_m = 0.0123$

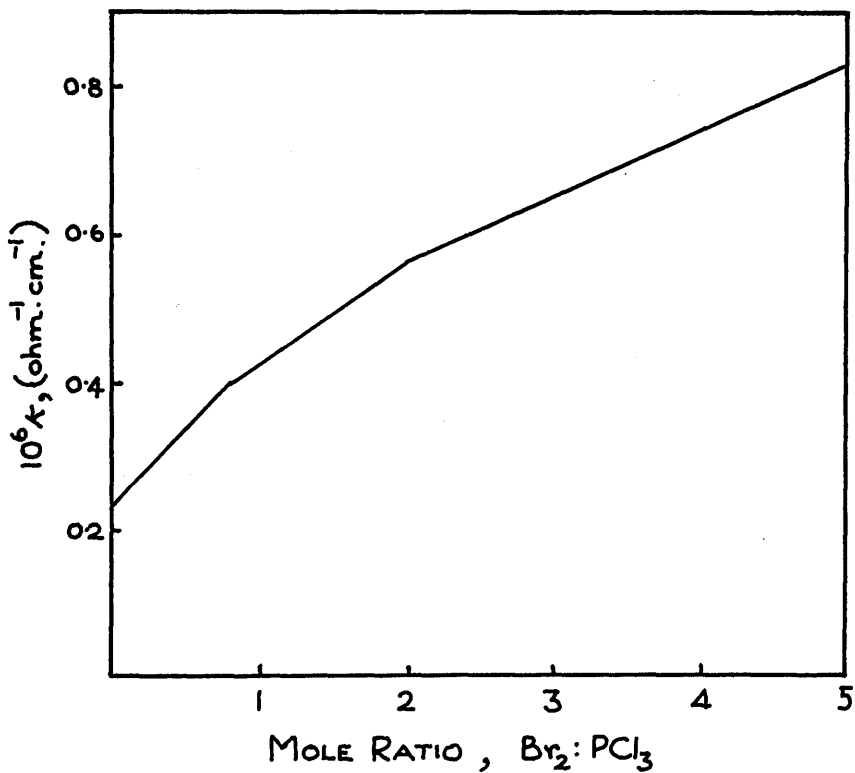

Fig. 15. Conductometric Analysis of the System
PCl₃ - Br₂ - POCl₃.

That is, the values are about equal to the molar conductance of bromine in phosphorus oxychloride, hence the rise in conductance during the titration is in large part due to the introduction of bromine to the solution. The inflections on the titration curve may have little significance but it is interesting to note that they appear at the integral mole ratios 1 and 2.

Conclusions.

Only in the case of nitrobenzene solutions is there any definite evidence that phosphorus trichloride and bromine interact with the formation of ions, and the conductometric analysis graph indicates that the ionic complexes formed in this system have probably the compositions PCl_3Br_4 and PCl_3Br_8 . This is interesting since Fialkov and Kuz'menko [52] have reported the isolation of PCl_3Br_4 , and their viscosity experiments [53] suggest the existence of a compound with the formula PCl_3Br_8 . From the values of conductance found in the system, these compounds, if they

exist, must be ionised to a very small extent, and it would seem that in this system the molecular type of dissociation might play an even more important rôle than it does in the phosphorus tribromide - bromine - nitrobenzene system.

The following table shows the results of the analysis of the products obtained from the reaction of phosphorus pentachloride with nitrobenzene at 100°C. The results are given in terms of the percentage of the various products. The total percentage of the products is 100.0. The difference between the total percentage and 100.0 is due to the presence of water in the products.

consideration may be given to the following:

- (1) $\text{PCl}_5 + \text{C}_6\text{H}_5\text{NO}_2 \rightleftharpoons \text{PCl}_4\text{O}_2 + \text{C}_6\text{H}_5\text{Cl}$
- (2) $\text{PCl}_5 + 2 \text{C}_6\text{H}_5\text{NO}_2 \rightleftharpoons \text{PCl}_3 + \text{C}_6\text{H}_4\text{ClNO}_2$
- (3) $\text{PCl}_5 + 3 \text{C}_6\text{H}_5\text{NO}_2 \rightleftharpoons \text{POCl}_3 + \text{C}_6\text{H}_3\text{Cl}_2\text{NO}_2$

which are in fact special cases of the general reaction...

CRYOSCOPIC STUDY OF THE SYSTEM PHOSPHORUS TRICHLORIDE -
BROMINE - NITROBENZENE.

A study of the association of phosphorus trichloride and bromine occurring in nitrobenzene solution was carried out by estimating cryoscopically the number of particles present in the system and relating this to the most likely equilibria. Values of the freezing point of the nitrobenzene solution containing different ratios of $\text{Br}_2:\text{PCl}_3$ (PCl_3 constant) are given in Table 13, and the linear relationship between these two quantities is shown in Fig. 16.

Consideration was given to the following equilibria

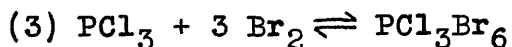
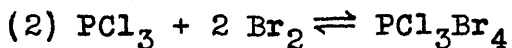
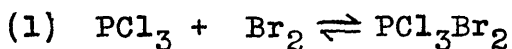

which are in fact special cases of the general equilibria -

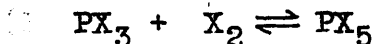
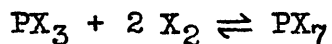

Table 13. Freezing Points in the System PCl₃ - Br₂ - nitrobenzene.

Mole Ratio Br ₂ :PCl ₃	Freezing Pt. (Relative)
0	5.194
0.4568	4.981
0.9261	4.786
1.4525	4.585
1.8729	4.409
2.3004	4.250
2.7648	4.086
3.0186	3.993



and for the present purposes it matters not whether X is Br or Cl.

The expressions derived for these were identical in all respects to those derived for the phosphorus

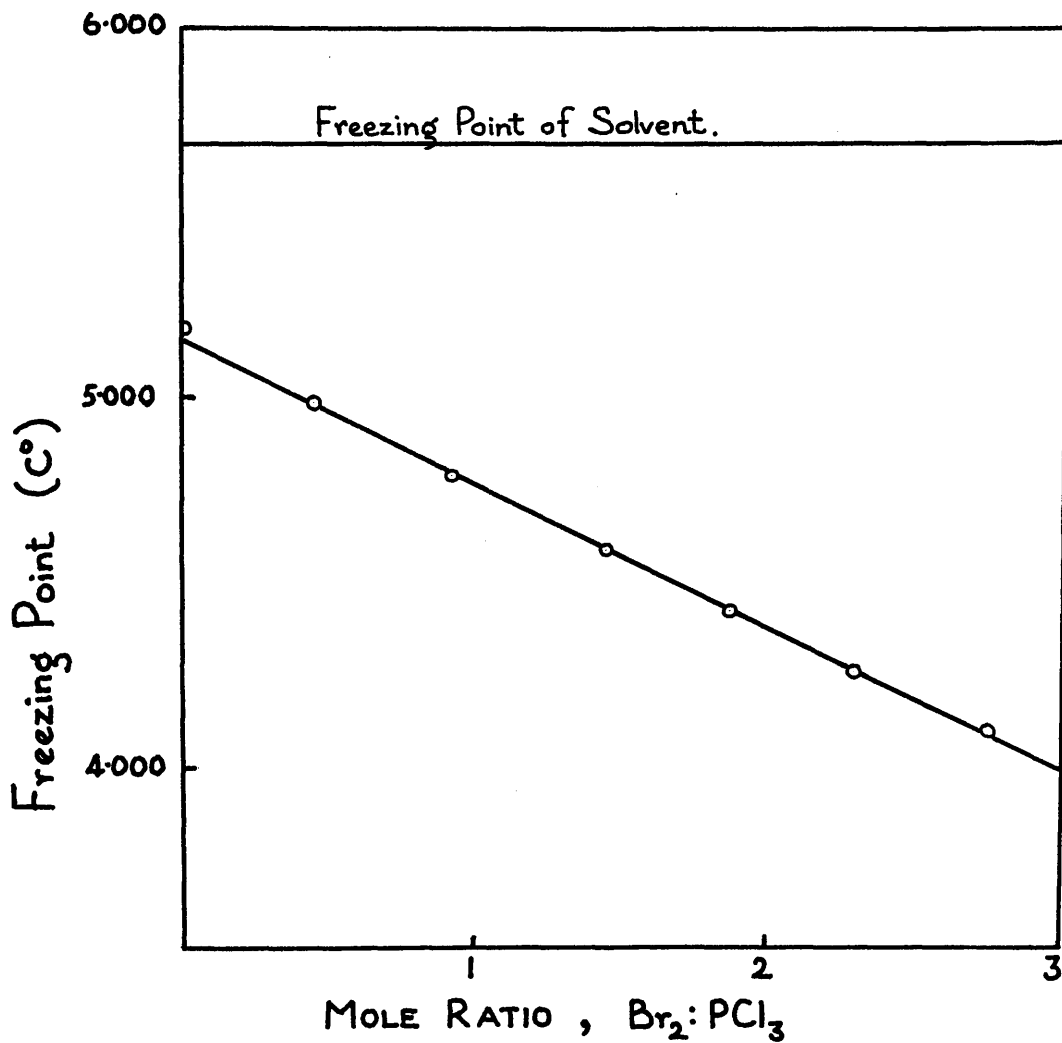

Fig. 16. Freezing Points in the System PCl₃ - Br₂ - nitrobenzene.

tribromide - bromine - nitrobenzene system. Using the same notation as in Part I of the thesis, Table 14 shows the values of the association constants, ${}_rK_1$, ${}_rK_2$ and ${}_rK_3$ (r = mole ratio $\text{Br}_2:\text{PCl}_3$) calculated from the experimental data.

Table 14. Association Constants for the Equilibria (1), (2), and (3).

PCl_3Br_2	PCl_3Br_4	PCl_3Br_6
${}_1K_1 = 2.259$	${}_1K_2 = 14.479$	${}_1K_3 = 130.52$
${}_2K_1 = 3.401$	${}_2K_2 = 9.758$	${}_2K_3 = 43.46$
${}_3K_1 = 4.859$	${}_3K_2 = 7.693$	${}_3K_3 = 22.08$

It is evident therefore that no one of the above equilibria describes the system satisfactorily. Once again the expressions for equilibria (1) and (2) were combined by introducing the arbitrary factor \mathcal{X} , and by doing so the figures shown in Table 15 were obtained.

By plotting values of ${}_rK_1$ and ${}_rK_2$ against \mathcal{X} , it

Table 15. Association Constants for the Mixed Equilibria.

\mathcal{X}	${}_1K_1$	${}_1K_2$	${}_2K_1$	${}_2K_2$	${}_3K_1$	${}_3K_2$
0	0	14.48	0	9.759	0	7.696
1	0.792	9.443	0.660	7.862	0.570	6.792
2	1.170	6.978	1.105	6.584	1.019	6.076
3	1.393	5.543	1.427	5.665	1.383	5.497
4	1.541	4.595	1.668	4.969	1.684	5.021
5	1.645	3.927	1.853	4.429	1.938	4.622
∞	2.259	0	3.401	0	4.860	0

was found that the ${}_rK_1$ -family of curves intersected at $\mathcal{X} = 3.12$ and the ${}_rK_2$ -curves intersected at the same value. At this point therefore,

$${}_1K_1 = {}_2K_1 = {}_3K_1 = 1.43$$

$$\text{and } {}_1K_2 = {}_2K_2 = {}_3K_2 = 5.45$$

The corresponding degrees of association were calculated and the results are set out in Table 16.

The system phosphorus trichloride, - bromine in

Table 16 Results of cryoscopic study of the system $\text{PCl}_3 - \text{Br}_2 - \text{C}_6\text{H}_5\text{NO}_2$.

Mole Ratio $\text{Br}_2:\text{PCl}_3$	Total Br_2 Concn.	PCl_3Br_2	PCl_3Br_4	$r\alpha_1 / r\alpha_2$
1:1	0.0839	$\alpha_1 = 0.09036$	$\alpha_2 = 0.02492$	$\alpha_1 / \alpha_2 = 3.625$
2:1	0.1678	$2\alpha_1 = 0.1560$	$2\alpha_2 = 0.08379$	$2\alpha_1 / 2\alpha_2 = 1.861$
3:1	0.2517	$3\alpha_1 = 0.1940$	$3\alpha_2 = 0.1552$	$3\alpha_1 / 3\alpha_2 = 1.249$

For equilib., $\text{PCl}_3 + \text{Br}_2 \rightleftharpoons \text{PCl}_3\text{Br}_2$, $K(5.70^\circ\text{C}) = 1.43 \text{ mole}^{-1}\text{litre.}$

For equilib., $\text{PCl}_3 + 2 \text{Br}_2 \rightleftharpoons \text{PCl}_3\text{Br}_4$, $K(5.70^\circ\text{C}) = 5.45 \text{ mole}^{-2}\text{litre.}^2$

nitrobenzene can be satisfactorily described by considering the presence of the two equilibria -

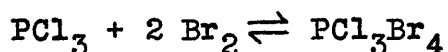
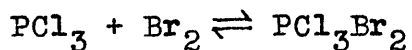

in the proportion indicated by the ratio $r\alpha_1 / r\alpha_2$.

ATTEMPTS TO PREPARE AN ADDUCT OF PHOSPHORUS TRICHLORIDE
AND BROMINE.

Previous attempts to prepare phosphorus bromide chlorides involved the bringing together of phosphorus trichloride and bromine in the absence of a solvent, and it is very doubtful if a compound of formula PCl_3Br_2 was ever obtained. It was decided to investigate the possibility of isolating phosphorus bromide chlorides from solutions of the components in suitable solvents since under these conditions one particular species might predominate. The use of solvents seems more satisfactory than direct interaction of phosphorus trichloride and bromine, for it avoids the occurrence of local excesses in concentration, and should permit the more ready separation of liquid and solid phases.

Solutions containing phosphorus trichloride and bromine in the ratio 1:1 were prepared in various solvents (the concentration of these solutions was ca. 0.5M with respect to PCl_3Br_2) and a solution of bromine of the same concentration was also prepared for colour comparison. The following observations

were made for each of the solvents indicated.

Acetonitrile.

Mixing of phosphorus trichloride and bromine in acetonitrile was accompanied by the evolution of heat, and on standing the colour of the solution diminished to pale yellow. It has been established (p. 94) that reaction with the solvent occurs in this case.

Nitrobenzene.

On mixing the components in this solvent no heat was evolved and cooling of the solution did not bring about crystallisation of a solid. The colour of the nitrobenzene solutions did not alter on standing. It was noted that the vapour of the bromine solution was darker in colour than the vapour over the mixture.

1:4 - Dioxan.

From this solvent an orange-yellow precipitate (m.p., 67 - 68 °C.) was obtained, and this was shown to be identical with the addition compound

$C_4H_8O_2 \cdot Br_2$ (m.p. 66 °C) of dioxan and bromine (mixed melting-point with an authentic specimen, 67 - 68 °C).

Phosphorus Oxychloride.

No heat was evolved on mixing phosphorus trichloride and bromine in this solvent, and cooling of the solution did not produce a precipitate. The colour of these solutions was quite stable.

Ethylene Dichloride.

The observations made were similar to the previous case.

Carbon Tetrachloride.

In this solvent no heat was evolved when the components were mixed, but at the concentration used two layers separated, both of which were deep red in colour, but the lower slightly darker. More solvent was added until the solution was homogeneous, and then the solution was cooled to 2 °C. After 24 hours dark red crystals had formed in the

liquid and on the walls of the vessel above the level of the liquid (thus showing that the crystals have a tendency to grow from the vapour phase). The crystals had a melting-point of 15 - 16 °C (the melting-point of the lower layer formed when the solutions were initially mixed also had a value of 15 - 16 °C).

Analysis of the Material.

A technique was developed for removing this low-melting solid for analysis, and the result of a complete analysis is summarised :-

P	Br	Cl	Total
3.65	65.30	14.02	82.97 %

It therefore appears that the compound contains carbon tetrachloride of solvation to an extent of 17.03 %, and this confirms the observation that the the aqueous solution containing the hydrolysed compound possessed a strong odour of carbon tetrachloride.

The analytical figures do not correspond exactly with any of the more likely formulae, but the closest agreement is obtained for a compound of composition $\text{PCl}_3\text{Br}_6\cdot\text{CCl}_4$ which requires -

P	Br	Cl	CCl ₄
4.01	62.24	13.80	19.95 %

A bromide chloride of phosphorus containing three atoms of chlorine and six atoms of bromine has not received special mention in the literature, and in particular it is noted that Fialkov and Kuz'menko do not mention this compound in their papers. Since these latter authors have described a method of preparing the compound PCl_3Br_4 which involves at one stage crystallisation from carbon tetrachloride, it was thought worth while repeating this preparation to discover if the method (as described by Fialkov et al., [52]) did in fact yield a product which contained no carbon tetrachloride. This was done and on hydrolysing the material there was produced a measurable quantity of liquid carbon tetrachloride. The amount of carbon tetrachloride in the sample was estimated as about 29.9 %, and a total halogen estimation revealed that 1 g. of the compound required 8.10 cc. of N silver nitrate solution for complete precipitation of the halide ion. These results again fit best with a com-

pound containing three chlorine and six bromine atoms but in this case there are two molecules of carbon tetrachloride of solvation thus, $\text{PCl}_3\text{Br}_6 \cdot 2\text{CCl}_4$. This composition requires $\text{CCl}_4 = 33.3 \%$ and 1 g. requires 9.70 cc. N silver nitrate solution.

The crystalline material obtained had a melting-point of ca. 15 °C, whereas that obtained by Fialkov and Kuz'menko melted at 37.7 °C.

Summarising, it has been found that the following reactions take place :-

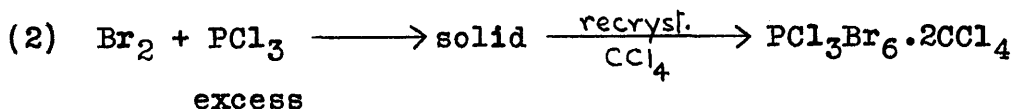
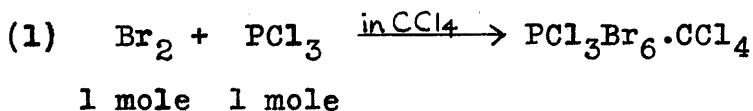

According to Fialkov and Kuz'menko the sequence shown in (2) should have resulted in a solid phase of composition PCl_3Br_4 .

It is evident that, no matter what the correct stoichiometry of the reaction between phosphorus trichloride and bromine in carbon tetrachloride is, the

solid phase of m.p. 15 - 16 °C crystallises with molecules of solvation. This is perhaps not surprising in view of the fact that phosphorus pentabromide and pentachloride when crystallised from the same solvent, form the solid solvates $\text{PBr}_5 \cdot 2\text{CCl}_4$ and $2\text{PCl}_5 \cdot \text{CCl}_4$ [54]. In these cases the carbon tetrachloride is present in an ionic lattice but in the present case, considering the relatively low conductance values found for the systems phosphorus trichloride - bromine - solvent, it may be that the lattice is a molecular one. The non-stoichiometry of the compounds could be explained by considering the crystal as built up of a molecular bromine lattice in which some bromine molecules are replaced by phosphorus trichloride or carbon tetrachloride molecules.

In summing up, it is clearly established that solid materials can be isolated from the phosphorus trichloride - bromine system directly or from solution, but the analytical figures obtained for these solids are not satisfactory, and the results of this investigation demonstrate that crystallisation from carbon

tetrachloride yields solvated products. It would appear that a direct structural investigation of these crystals might yield some useful information regarding the part played by the carbon tetrachloride molecule in their build up.

The work that has been done on the liquid state of the phosphorus bromide chlorides (viscosity and some conductance measurements by Fialkov and Kuz'menko) has not yielded any substantial information concerning the nature of these compounds. In further investigations of this state, consideration should be given to the changes in molar volumes and absorption spectra with composition, since it might be expected that these properties would give further indication of the exact nature of the system.

Nothing is known of the state of these compounds in the vapour phase. The work on non-aqueous solutions of the systems is more advanced and we have, above, some information on the electrolytic properties of the solutions and of the possible existence of PX_5 and PX_7 entities.

EXPERIMENTAL PART

PURIFICATION OF MATERIALS.

The purification of acetonitrile, bromine, carbon tetrachloride, and nitrobenzene, has been described in Part I of the thesis.

Phosphorus Trichloride.

Phosphorus trichloride (Tyrer) was fractionated using a two foot column packed with Fenske rings, and the fraction distilling at 74.4 - 74.5 °C (760 mm.) was taken for further purification. This was done by vacuum fractional distillation as described for the purification of phosphorus tribromide in Part I (page 64). The pure compound was stored in sealed ampoules.

Phosphorus Oxychloride.

The commercial material (Albright and Wilson) was distilled several times through a short column and the middle portion of the final distillation was taken for use.

b.p. = 105.4 - 105.8 °C (760 mm.)

$\kappa = 3.27 \times 10^{-7} \text{ ohm}^{-1}\text{cm}^{-1}$ at 25 °C.

1:4 - Dioxan.

This material was purified by a modified version of the method described by Kraus and Vingee [55]. Commercial (M. and B.) 1:4 - dioxan (250 cc.) was refluxed for 14 hours over metallic sodium (1.5 g.) and the dioxan was then distilled directly from the resulting muck.

b.p. = 101.0 °C (760 mm.)

$\kappa = < 10^{-7} \text{ ohm}^{-1}\text{cm}^{-1}$ at 25 °C.

Ethylene Dichloride [56].

The B.D.H. material (500 cc.) was shaken with portions of concentrated sulphuric acid until the acid layer remained colourless (800 cc. required). This was followed by washing with a large amount of water until the aqueous layer was almost neutral (litmus). The ethylene dichloride was then washed twice with dilute sodium bicarbonate solution and finally with water. The material was submitted to

a preliminary drying with anhydrous sodium sulphate after which it was dried azeotropically (first 10 % discarded). Refluxing for two hours over phosphorus pentoxide and distilling twice from this drying agent served to remove the last traces of water.

b.p. = 83.0 - 83.5 °C (755 mm.)

CONDUCTOMETRIC ANALYSES.

These experiments were performed in the apparatus described in Appendix 3. Solutions were prepared by breaking a bulb containing a known weight of the solute under a known weight of solvent. In each case the bromine solution was the titrant.

DEPRESSION OF FREEZING POINT EXPERIMENT.

The apparatus for this work is described in Appendix 5. The general procedure was to find the freezing point of the solvent,

and then of the solution after the addition of the required amount of phosphorus trichloride. Bromine (enough to cover a range of mole ratios 1 - 3) was then added in stages and the freezing point of the solution determined at each stage.

PREPARATION AND ANALYSIS OF AN ADDUCT OF PHOSPHORUS TRICHLORIDE AND BROMINE IN CARBON TETRACHLORIDE SOLUTION.

Preparation. Phosphorus trichloride (0.1 mole) in carbon tetrachloride (5 cc.) and bromine (0.1 mole) in carbon tetrachloride (5 cc.) were mixed, and this brought about the separation of two liquid phases. The solution was made homogeneous by adding more solvent (10 cc.) and left overnight at 2 °C. The deep red crystals which formed were freed from solvent by allowing the latter to drain away for some hours, while still maintaining the solution at 2 °C.

Analysis. Since the crystals had a melting-point of 15 - 16 °C they were transferred to a flask for weigh-

ing by allowing them to melt and flow into the flask. The molten material (weight = ca. 0.4 g.) consisted of two immiscible liquids, and this was hydrolysed by dilute sodium hydroxide solution in a closed system. (The resultant solution was found to possess a definite odour resembling that of carbon tetrachloride). The alkaline solution (which was yellow in colour) was reduced by the passage of sulphur dioxide (5 min.), and after acidification with dilute nitric acid the excess sulphur dioxide was expelled by boiling the solution while passing carbon dioxide through it. The resulting solution was evaporated and made up to the mark in a standard flask (100 cc.), and aliquot portions of this were used in the analysis for phosphorus, bromine, and total halogen.

Phosphorus.

To 25 cc. of the hydrolysed solution, AnalaR concentrated nitric acid (5 cc.) was added and evaporated on a water bath to a bulk of a few cc. Fuming nitric acid (1 cc.) was then added and the solution heated again. After dilution, the phosphorus

(then present entirely as phosphate) was precipitated as magnesium ammonium phosphate which was ignited at 900 °C to magnesium pyrophosphate and weighed as such.

Total Halogen.

This was done by taking 10 cc. portions of the hydrolysed solution and estimating the halide ion content by Volhard's method.

Bromine.

The method adopted for the estimation of bromide in the presence of chloride was that described by Kolthoff and Yutzy [57] who developed the method for the analysis of bromide in brines. The principle of the method is the oxidation of bromide to bromate by sodium hypochlorite solution, selective destruction of the excess hypochlorite, and finally estimation of the bromate ion iodometrically.

The hydrolysed solution (2 cc.) was taken, diluted to 25 cc., and the resulting solution made neutral to methyl red. To this solution were added sodium dihydrogen phosphate (1 g.), sodium chloride (10 g.),

and N sodium hypochlorite solution (5 cc.). The solution was then heated to boiling and sodium formate solution (5 cc., which contained 2.5 g. of the solid) was added, after which the solution was allowed to cool. Potassium iodide (1 g.), sulphuric acid (25 cc. of 6N), and ammonium molybdate (1 drop of a 0.5N solution) were then added. The liberated iodine was immediately titrated with standard sodium thiosulphate solution (approximately centinormal). A blank titration was carried out and the volume of thiosulphate solution subtracted from that found in the test.

PREPARATION OF PCl_3Br_4 AS DESCRIBED BY FIALKOV AND KUZ'MENKO. [52]

The addition of bromine (0.048 mole) to phosphorus trichloride (0.064 mole) resulted in the liberation of heat and the formation of two liquid layers. The uppermost layer was sucked off and the lower layer allowed to cool to room temperature, but crystallisation of this material did not occur (as is implied in the

paper by Fialkov and Kuz'menko). However on cooling to 1 °C the viscid liquid was found to crystallise. The bulk of this material melted at about 15.5 °C but some needles which had formed on the wall of the vessel did not melt completely until about 25 °C.

Recrystallisation. The substance, which was liquid at room temperature, was with difficulty soluble in carbon tetrachloride. The solution was kept at 1 °C overnight and deep red crystals were found to have grown from the solution. The solvent was decanted and the last traces of carbon tetrachloride were removed by passing a stream of dry carbon dioxide over the crystals (the carbon dioxide appeared to carry away some bromine vapour during this operation). On standing at room temperature the crystals melted producing two phases — a heavy, dark red layer and a lighter red layer.

Analysis. Hydrolysis of the substance with dilute sodium hydroxide solution produced carbon tetrachloride in sufficient quantity for its volume to be measured directly.

After reducing the halogen to halide as before, the total halogen content of the substance was estimated by Volhard's method.

P A R T III

SOME TRIPHENOXYPHOSPHORUS DIHALIDES

I N D E X

	Page
NOMENCLATURE	128
INTRODUCTION	129 - 140
STABILITY OF THE COMPOUNDS	141 - 143
RESULTS AND DISCUSSION	144 - 191
1. Conductance Experiments.	144
(a) The Conductance of Triphenyl Phosphate and Hydrogen Chloride in Acetonitrile.	144
(b) The Electrolytic Conductance of Triphenoxyphosphorus Dichloride in Acetonitrile.	148
(c) A Conductometric Study of the Hydrolysis of Triphenoxyphosphorus Dichloride.	151
2. Conductometric Analysis of the System Triphenyl Phosphite - Bromine.	155
3. The Electrolysis of Triphenoxyphosphorus Dibromide in Acetonitrile.	165
4. Electrolysis of $[(C_6H_5O)_3P]_2Br_2$ in Acetonitrile.	169
5. Reaction between Phenol and Phosphorus Pentabromide.	179
6. Conductometric Analysis of the System Triphenyl Phosphite - Iodine.	187
EXPERIMENTAL PART	192 - 207
1. Materials.	192

	Page
(a) Hydrogen Chloride.	192
(b) Triphenyl Phosphate.	195
(c) Triphenoxyphosphorus Dichloride.	195
(d) Triphenyl Phosphite.	196
(e) Iodine.	196
(f) Phenol.	196
2. Conductance Experiments.	197
3. Conductometric Analyses.	199
4. Electrolysis Experiments.	200
5. Preparation and Analysis of Triphenoxyphosphorus Tetrabromide.	205

INDEX.

In the case of simple inorganic compounds and ions the familiar inorganic nomenclature is adopted in which radicals of the type $(\text{R}_3\text{P})^+$ are regarded as simple triphenyl phosphorus ions; for example $(\text{C}_6\text{H}_5)_3\text{P}^+\text{Br}^-$ is called the tetrabromotriphenyl phosphorus ion.

NOMENCLATURE

The nomenclature used in this section to describe organophosphorus compounds follows that suggested by Kosolapoff ["Organophosphorus Compounds", Wiley, New York, 1950. p.4]. The older names for the quasi-phosponium compounds have been slightly modified, for example triphenyl phosphite dichloride is replaced by triphenoxyphosphorus dichloride. When the structure of a particular triphenoxyphosphorus dihalide is known and it is desired to describe the compound in terms of this structure, the name is accordingly altered. For example triphenoxyphosphorus di-iodide would be called iodotriphenoxyphosponium iodide.

In the case of simple inorganic compounds and ions, the familiar inorganic nomenclature is adhered to. Anions of the type $[\text{PX}_6]^-$ are regarded as substituted phosphate ions ; for example $[(\text{C}_6\text{H}_5\text{O})_3\text{PBr}_3]^-$ is called the tribromotriphenoxyphosphate ion.

INTRODUCTION

Compounds of pentavalent phosphorus with the general formula $(RO)_3PX_2$, in which R is an alkyl or aryl radical and X a halogen atom, have been mentioned from time to time in the literature, either as simple compounds or as probable intermediates in certain reactions involving organophosphorus compounds. The compounds are very labile and in only a few cases has isolation in the pure state been achieved, and those compounds which have been well characterised are found to belong, without exception to the series in which R is an aryl or substituted aryl radical.

Certain members of the series of compounds in which R is a phenyl radical have been reported frequently, and the present investigation has been confined to a further study of these compounds ; that is, compounds of general formula $(C_6H_5O)_3PX_2$ have been considered.

In 1883, Noack [58] allowed bromine to react with an equivalent amount of triphenyl phosphite, and he observed that the product of the reaction was not what

would be expected if the reaction had followed the same course as the known reaction between triethyl phosphite and bromine, namely,

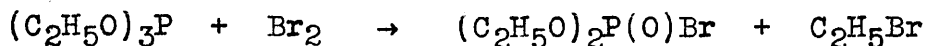

On the contrary, Noack obtained a yellow crystalline substance which on analysis gave results which corresponded exactly with a compound of composition , $(\text{C}_6\text{H}_5\text{O})_3\text{PBr}_2$. Thus it appeared that the reaction was a simple addition reaction resulting in the formation of triphenoxyphosphorus dibromide.

Several years later, Anschütz and Emery [59] succeeded in isolating triphenoxyphosphorus dichloride, by a method analagous to that used in the preparation of the dibromide.

In the course of an investigation of the reaction between phosphorus pentachloride and phenol, Autenrieth and Geyer [60] isolated a compound of formula $\text{C}_{18}\text{H}_{15}\text{O}_3\text{PCl}_2$, which was found to be identical with the triphenoxyphosphorus dichloride obtained by Anschütz and Emery.

Thus two different methods of synthesising the triphenoxyphosphorus dihalides were made available. In the first method use is made of the tendency of triphenyl phosphite to take part in addition reactions. This tendency is a prominent feature of compounds containing a trivalent phosphorus atom. In the second method of formation of triphenoxyphosphorus dihalides, the phosphorus atom is initially in the pentavalent state and the reaction involves the replacement of three halogen atoms of the pentahalide by phenoxy groups.

Recent preparative work on the triphenoxyphosphorus dihalides is contained in a paper by Coe, Landauer, and Rydon [61]. These authors make use of the addition reaction of triphenyl phosphite and halogens and report the preparation of six crystalline dihalides — triphenoxyphosphorus dichloride, dibromide, di-iodide, bromochloride, bromoiodide, and chloroiodide.

It must be kept in mind that the series of triphenoxyphosphorus dihalides represents a special case of a much larger family of compounds which can be

represented by the general formula $(C_6H_5O)_nPX_{5-n}$ where $n = 1, 2, \dots, 5$. Many of these additional halides have been prepared and as will be seen their existence has an important bearing on certain parts of the present work.

Anschütz et al. [59, 62] found that phenyl dichlorophosphite and diphenyl chlorophosphite were capable of adding on another chlorine molecule to produce respectively compounds of formulae $(C_6H_5O)PCl_4$ and $(C_6H_5O)_2PCl_3$. In the same way a molecule of bromine could be added yielding $(C_6H_5O)PCl_2Br_2$ and $(C_6H_5O)_2PClBr_2$. This latter reaction is of particular interest in view of the reluctance of phosphorus trichloride to take part in an addition reaction with bromine to form PCl_3Br_2 [Part II of this thesis].

In their work on the aromatic derivatives of the hypothetical orthophosphoric acid, Anschütz, Boedeker, Broecker, and Wenger [63] summarise the situation by stating that from the following regular series of compounds, only the fifth member is missing -



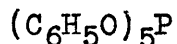
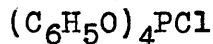
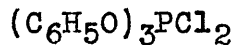
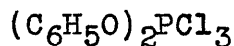
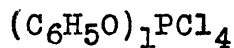

Certain results contained in this thesis indicate that a compound of formula $(\text{C}_6\text{H}_5\text{O})_4\text{PCl}$ does exist under certain conditions, and collateral proof of this has recently come from its isolation by Rydon and his co-workers [64]. They obtained it by allowing 1 mole of chlorine to react with 2 moles of triphenyl phosphite and recrystallising the solid product from a 1:1 mixture of chlorobenzene and ethylene dichloride. It was also obtained by heating together at 120 °C, 1 mole of phosphorus pentachloride and 4 moles of phenol.

The series of compounds of general formula $(\text{C}_6\text{H}_5\text{O})_n\text{PX}_{5-n}$ is considered by Anschütz et al. [65, 66] in a discussion of the nature of the valency of phosphorus when bound to five electronegative ligands. The view is put forward that the reactivity of this group of compounds is due to electrostatic repulsion of

the electronegative halogen atoms. In consequence of this, the reactivity diminishes as the halogen atoms are replaced by phenoxy groups. The same authors tried to obtain information on the steric properties of the phosphorus to ligand bonds, but their experiments yielded negative results.

All of the compounds of this group are by formulation related to the true phosphonium compounds and this relationship is borne out by the chemical properties of the compounds. For example thermal decomposition is accompanied by the formation of the aryl halide. Hydrolytic decomposition results in the formation of the corresponding phosphate esters :

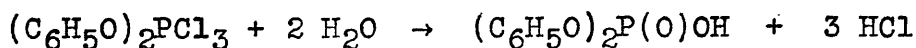
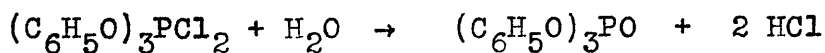

It is interesting that phenoxyphosphorus tetrachloride on hydrolysis yields triphenyl phosphate in addition to the expected product. Hence disproportionation must accompany hydrolysis [66, 67a]. Therefore it seems that consideration must always be given to the

possible occurrence of migration of phenoxy groups in these compounds.

This analogy between the true phosphonium compounds and the aryloxyphosphorus halides has earned the latter group the appropriate title of "Quasi-phosphonium Compounds".

Quasi-phosphonium structure has recently been postulated by Waters and de Worms [68] for an intermediate in the hydrolysis of di-isopropyl fluorophosphate. The suggestion was made when the hydrolysis, in contrast with the hydrolysis of acyl halides, was found to be catalysed by hydrogen ions. Gerrard et al. [69] have also envisaged this type of structure in various reaction mechanisms.

Recent interest in triphenoxyphosphorus dichloride has been in its application in a new method of preparing alkyl halides in good yield [61]. Triphenoxyphosphorus dichloride reacts with alcohols according to the equation :

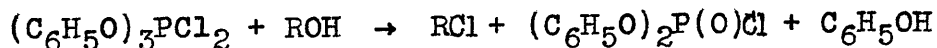

Similar experiments with triphenoxyphosphorus di-interhalides produced results which exhibited an interesting anomaly. It was found that the bromochloride and the chloriodide yielded preferentially the alkyl bromide and iodide respectively. But the bromiodide gave the alkyl bromide in greater yield.

Rydon in proposing a mechanism for the reaction suggests that the first stage involves ester exchange :

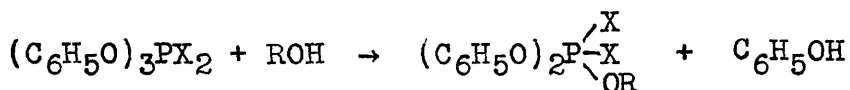

The assumption is then made that the ester-exchanged intermediate ionises and this is followed by attack on the exchanged alkyl group by the halide ion :

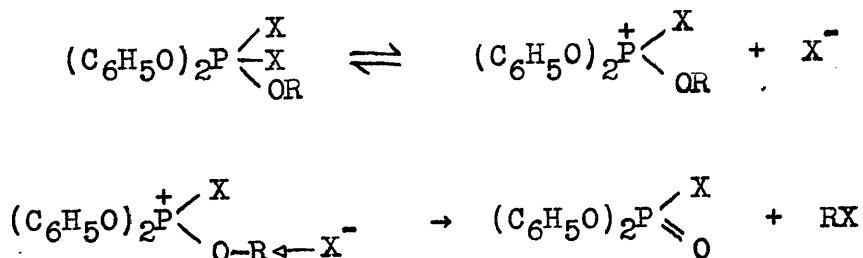

From the results of the experiments with triphenoxy-bromochloride and chloriodide, it appears to be the bromine and iodine atoms which come off as ions,

and not as might be expected, the more electronegative chlorine atom. This is understood when the strengths of the phosphorus to halogen bonds are considered. These diminish in the order $P-Cl > P-Br > P-I$. Thus the formation of alkyl bromides and iodides appears to be essentially a consequence of the greater strength of the $P-Cl$ bond.

The bromiodide is quite clearly irregular in its behaviour since it does not fit in with the above argument. The explanation put forward is that the inhibitory effect of bromine on the ionisation of iodine exceeds that of iodine on the ionisation of bromine. Consequently the bromine atom comes off as a bromide ion despite the greater strength of the $P-Br$ bond.

It is evident from the problems outlined above, that the greatest drawback in the understanding of the reactions of triphenoxyphosphorus dihalides, is the complete lack of knowledge of the true nature of the compounds in this group. An investigation designed to reveal the structure and properties of the various compounds would clearly throw light on the existing

problems and in addition contribute to our present knowledge of halides of pentavalent phosphorus.

The two methods of formation of triphenoxyphosphorus dihalides —

- (a) addition of a halogen molecule to triphenyl phosphite (Cf. the preparation of PX_5 from PX_3 and X_2).
- (b) substitution in the phosphorus pentahalide molecule.

— strongly suggest that these compounds might bear a simple relationship to the better known inorganic pentahalides of phosphorus. It is with these ideas in mind that the present work was undertaken.

The only previously reported physico-chemical approach to the study of quasi-phosponium compounds is that of Forsman and Lipkin [70] who made a systematic study of the reaction between iodine and triphenyl phosphite. Their results conflict in part with those of Rydon since they were not able to isolate a diiodide from the system. However they isolated two polyiodides of formulae, $(C_6H_5O)_3PI_4$ and $(C_6H_5O)_3PI_9$.

It is suggested that both compounds contain the cation :

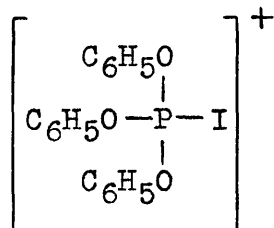

Triphenoxyphosphorus tetraiodide is presumed to be the tri-iodide of this iodotriphenoxyphosphonium cation. The enneaiodide is found to show no paramagnetic resonance absorption hence it is concluded that the structure does not contain a unit with an odd number of electrons. It therefore becomes necessary to double the simple formula — $\text{C}_{36}\text{H}_{30}\text{O}_6\text{P}_2\text{I}_{18}$. The proposed structure for this compound is one containing the cation $[(\text{C}_6\text{H}_5\text{O})_3\text{PI}]^+$ and equal numbers of I_7^- and I_9^- ions. A similar type of arrangement has been put forward for the structure of caesium tetraiodide. Here again the formula must be doubled and it is suggested that the crystal is built up from Cs^+ , I_3^- , and I_5^- units [71].

In no other case has the structure of triphenoxyphosphorus dihalides been discussed to any great length. In the following work, a study has been made of sol-

utions of the compounds in indifferent solvents, and physico-chemical methods have been used throughout in an attempt to discover the characteristic properties of the compounds. From the results obtained it has been possible to put forward a clearer and more complete picture of the nature of this group of quasi-phosphonium compounds.

STABILITY OF THE COMPOUNDS

Triphenoxyphosphorus dihalides resemble the inorganic phosphorus pentahalides in their very great ease of hydrolysis. Thus it is important in handling these compounds to prevent their coming into contact with moisture. The methods used to achieve this were similar to those described in the earlier parts of the thesis and in the Appendix.

The triphenoxyphosphorus dichloride used in this investigation was received from Professor H.N. Rydon. Preliminary measurements of the conductance of this material (labelled "triphenoxyphosphorus dichloride") in acetonitrile gave very discordant results. With some samples of the material, the molar conductance of the solution was found to increase with increasing concentration ; and with other samples the molar conductance decreased as the concentration was increased.

These observations suggested that an analytical study of the material ought to be made. The result of this indicated quite clearly that in every case the material was defective (low chlorine content).

Consultation with Rydon resulted in an investigation by the latter on his method of preparation. It soon became evident that the preparation of these compounds was not as straight-forward as was originally thought. It was established that repeated crystallisation was accompanied by a fall in halogen content. For example the dibromide, $(C_6H_5O)_3PBr_2$, on repeated crystallisation finally yielded a product whose analysis figures corresponded with the tetraphenoxy compound, $(C_6H_5O)_4PBr$.

In a private communication, Professor Rydon has put forward the suggestion that in the crystallisation medium the dihalide becomes a member of a complex equilibrium thus,

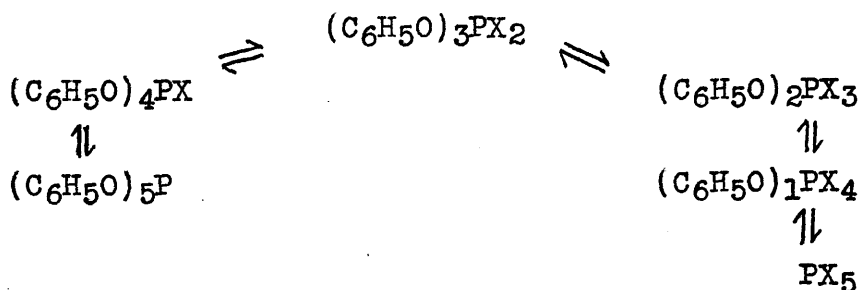

The compounds in the right-hand limb of this scheme being presumably more soluble, recrystallisation will

result in a fall in halogen content of the product. It is interesting to compare this with the observation made by Renc [51] during the recrystallisation of PClBr_4 and PCl_4Br from carbon disulphide. He found that repeated crystallisation of these compounds gave products which were richer in that halogen which was originally present in excess.

This initial obstacle has had several consequences. For instance it has made us realise that the compounds are even less stable and probably of greater complexity than was at first thought. In addition improved methods for the preparation of analytically pure specimens have been developed.

Measurements of the molar conductances of various phosphorus and hydrogen chlorides in molal solutions in carbon tetrachloride have shown that these compounds are virtually

RESULTS AND DISCUSSION

CONDUCTANCE EXPERIMENTS

The solvent used in these experiments was acetonitrile and the reasons for this are similar to those advanced in Part I of the thesis. As a preliminary to the investigation of the conductance of triphenoxyphosphorus dichloride in acetonitrile, a special study of the conductance of the hydrolysis products, triphenyl phosphate and hydrogen chloride, in the same solvent, was made. This step was considered to be necessary on account of the sensitivity of the triphenoxyphosphorus dihalides to moisture.

THE CONDUCTANCE OF TRIPHENYL PHOSPHATE AND HYDROGEN CHLORIDE IN ACETONITRILE

Measurement of the molar conductances of triphenyl phosphate and hydrogen chloride in acetonitrile solution has shown that these compounds are virtually non-conductors. The actual figures obtained were :

HCl $\Lambda_m = 0.14 \text{ ohm}^{-1} \text{ cm}^2 \text{ mole}^{-1}$ ($c_m = 0.0349$)

$(\text{C}_6\text{H}_5\text{O})_3\text{PO}$... $\Lambda_m = 0.06$ " " " ($c_m = 0.0986$)

The low value for the conductance of hydrogen chloride in acetonitrile is possibly due to the formation of the iminochloride [72].

It is not unreasonable to suspect that the solutions of hydrogen chloride in acetonitrile might become conductors in the presence of triphenyl phosphate. If the bond of the phosphoryl group in $(\text{C}_6\text{H}_5\text{O})_3\text{PO}$ were sufficiently polar then triphenyl phosphate could behave as a Lewis base and induce ionisation of the hydrogen chloride molecule.

This point was explored by titrating an acetonitrile solution of hydrogen chloride with a similar solution of triphenyl phosphate and observing the conductance of the mixture (addition of pure solvent brought about a decrease in the conductance of the hydrogen chloride solution). The results of the experiment are shown in Table 17 and Fig. 17. This shows quite clearly that the conductance of hydrogen chloride is only slightly

Table 17. Conductometric Titration of triphenyl phosphate and hydrogen chloride in acetonitrile.

Mole Ratio (C ₆ H ₅ O) ₃ PO: HCl	10 ⁶ κ ohm. ⁻¹ cm. ⁻¹	Mole Ratio (C ₆ H ₅ O) ₃ PO: HCl	10 ⁶ κ ohm. ⁻¹ cm. ⁻¹
0.00	9.30	1.37	10.89
0.09	9.63	1.83	11.03
0.27	9.96	2.28	11.12
0.46	10.19	2.74	11.29
0.91	10.59	2.97	11.29

affected by the presence of triphenyl phosphate in the same solution. The smooth character of the curve suggests the absence of interaction between the two solutes ; hence it is concluded that triphenyl phosphate does not act to any marked extent as an electron donor.

The molar conductance of the hydrogen chloride solution was initially 0.43 ohm.⁻¹ cm.² mole.⁻¹ ($\alpha_m = 2.28 \times 10^{-2}$) and when an equimolar amount of triphenyl phosphate had been added, this value rose to 0.59 ohm.⁻¹ cm.² mole.⁻¹,

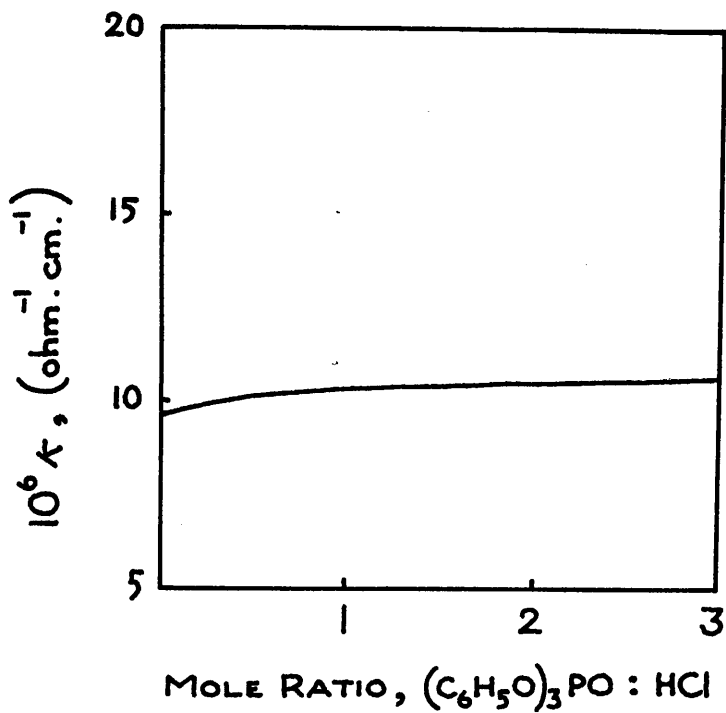

Fig. 17. Conductometric Titration of Triphenyl Phosphate and Hydrogen Chloride in Acetonitrile.

($c_m = 1.794 \times 10^{-2}$). When the mole ratio of hydrogen chloride to triphenyl phosphate was 2:1 (i.e. when the solution contained the hydrolysis products of triphenoxyphosphorus dichloride in the correct proportion) the molar conductance of the solution (with respect to hydrogen chloride) was calculated to be $0.53 \text{ ohm}^{-1} \text{ cm}^2 \text{ mole}^{-1}$ ($c_m = 1.94 \times 10^{-2}$).

It was concluded that if solutions of triphenoxyphosphorus dichloride proved to be highly conducting then this could be attributed without doubt to ionisation of the halide. It would then be safe to say that what was being measured was in fact the conductance of triphenoxyphosphorus dichloride.

THE ELECTROLYTIC CONDUCTANCE OF TRIPHENOXYPHOSPHORUS
DICHLORIDE IN ACETONITRILE

The conductance of analytically pure triphenoxyphosphorus dichloride in acetonitrile solution at 25°C was measured under strictly anhydrous conditions, and the results are shown in Table 18 and graphically in

Table 18. Conductance at 25°C of triphenoxyphosphorus dichloride in acetonitrile.

c_m Mole.litre ⁻¹	$10^4 \kappa$ Ohm. ⁻¹ cm. ⁻¹	Λ_m Ohm. ⁻¹ cm. ² mole ⁻¹
0.0074	7.5	100.8
0.0211	20.3	95.6
0.0398	35.5	89.2
0.0570	42.1	73.8

Fig. 18.

After a brief initial change whilst the solution attained the temperature of the thermostat bath, the conductance values were found to be constant over a period of 24 hours. The specific conductance had a positive temperature coefficient between 0 °C and 25 °C and in this temperature range there is a linear relationship between temperature and specific conductance. The numerical value of the coefficient is 2.25×10^{-6} ohm.⁻¹ cm.⁻¹ deg.⁻¹

Values of molar conductance bear a linear relation-

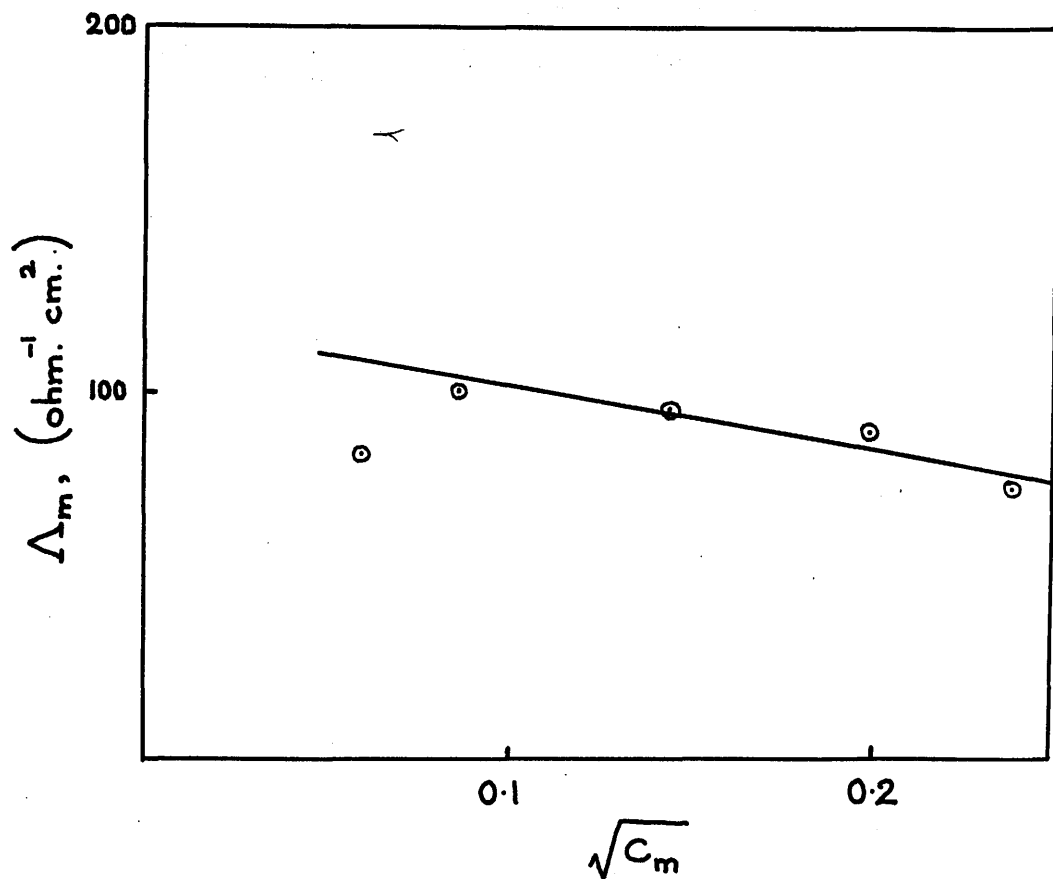

Fig. 18. Conductance of Triphenoxyphosphorus Dichloride in Acetonitrile.

ship to the square root of the concentration down to 0.006 M. Below this value the results are unreliable, probably due to the effect of traces of impurities in the solvent. An extrapolation of the curve obtained by plotting Λ_m against $\sqrt{c_m}$ gives an approximate value of the molar conductance at infinite dilution $\Lambda_{m,\infty} = 105 \text{ ohm}^{-1} \text{ cm}^2 \text{ mole}^{-1}$

The high conductance of these solutions can only be understood in terms of ionisation of the triphenoxyphosphorus dichloride.

A CONDUCTOMETRIC STUDY OF THE HYDROLYSIS OF TRI-PHENOXYPHOSPHORUS DICHLORIDE

Triphenoxyphosphorus dichloride dissolved in acetonitrile was hydrolysed by successive additions of traces of water, and the changes occurring were followed conductometrically. It was observed that the addition of water at first led to a marked fall in the conductance of the solution. A minimum value then occurred, after which the conductance began to rise

Table 19. Hydrolysis of Triphenoxyphosphorus Dichloride.

$10^4 \times$ moles H_2O	$10^4 \kappa$ $ohm.^{-1} cm.^{-1}$	$10^4 \times$ moles H_2O	$10^4 \kappa$ $ohm.^{-1} cm.^{-1}$
6.06	32.07	42.42	2.43
12.12	0.45	48.48	3.24
18.18	0.71	60.60	4.70
24.24	1.12	78.78	6.48
30.30	1.49	90.90	8.10
36.36	1.91	121.20	10.85

slowly. These results are expressed in Table 19 and in Fig. 19.

It is inferred that hydrolysis of the dihalide is rapid, and takes place in such a way as to afford products which are non-conductors in acetonitrile. The minimum conductance value occurred when the mole ratio of triphenoxyphosphorus dichloride to water was unity. The subsequent rise in conductance of the solution is presumably due to the ionisation of hydrogen chloride in the (now) aqueous acetonitrile.

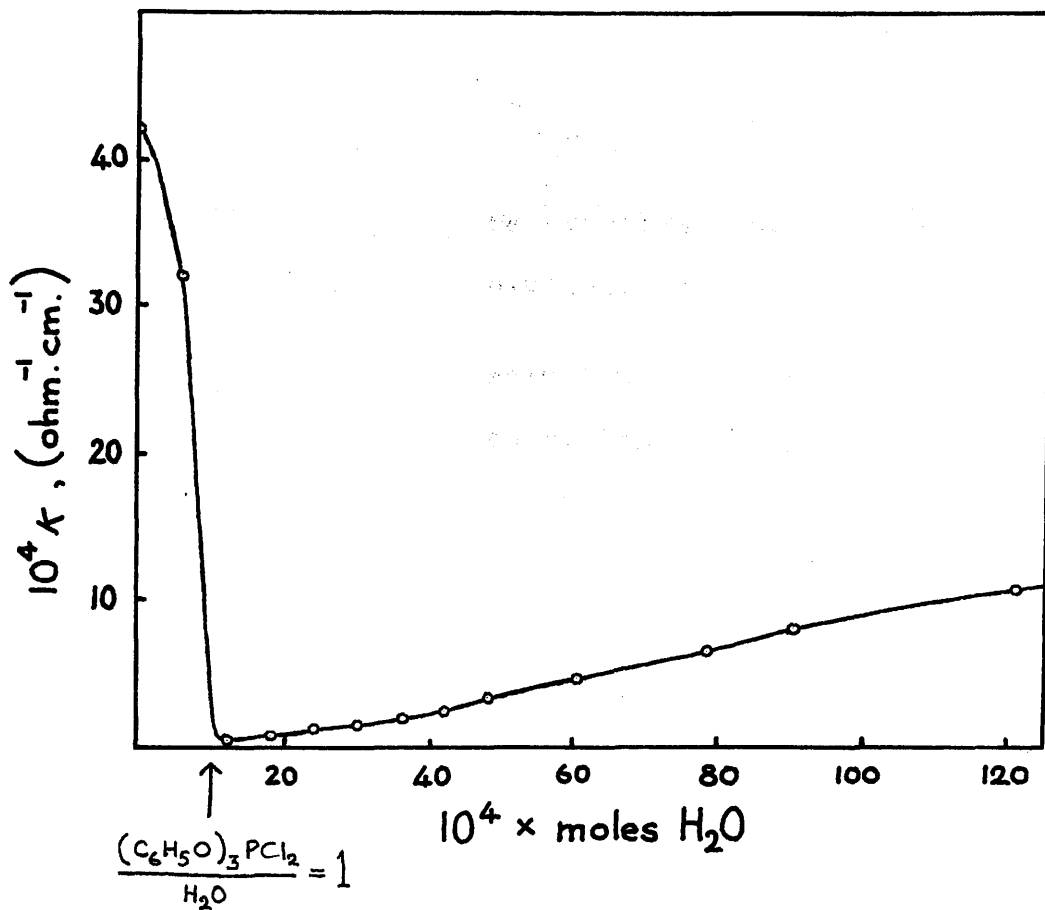
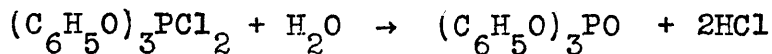

Fig. 19. Hydrolysis of Triphenoxyphosphorus
Dichloride

These results are in complete accordance with those obtained in the study of the conductance of hydrogen chloride and triphenyl phosphate in acetonitrile. The equation :



satisfactorily describes the hydrolysis of the dichloride in acetonitrile solution.

Slight hydrolysis of a solution of triphenoxyphosphorus dichloride caused by traces of impurities in the solvent will thus tend to produce low values for the molar conductance. This effect would be expected to become important as the dichloride concentration becomes smaller, hence values of conductance found at low concentrations cannot be regarded as reliable.

CONDUCTOMETRIC ANALYSIS OF THE SYSTEM TRIPHENYL
PHOSPHITE - BROMINE

The reaction between triphenyl phosphite and bromine is conveniently studied by conductometric titration since solutions of triphenyl phosphite and bromine in acetonitrile of known concentration are readily prepared. The results of such an experiment are recorded in Table 20 and illustrated graphically in Fig. 20.

Since individual solutions of bromine and triphenyl phosphite in acetonitrile are non-conductors, $[(C_6H_5O)_3P, \Lambda_m = 0.03 \text{ ohm.}^{-1} \text{ cm.}^2 \text{ mole.}^{-1} \text{ at } c_m = 0.014 ; \text{ Br}_2, \Lambda_m = 0.22 \text{ ohm.}^{-1} \text{ cm.}^2 \text{ mole.}^{-1} \text{ at } c_m = 0.033]$ then it is quite clear from the results that the interaction of triphenyl phosphite and bromine is an ion-forming process.

In interpreting the results therefore we must postulate the formation of species which undergo ionic dissociation.

From the shape of the graph it is evident that the

Table 20. Conductometric Analysis of the System
Triphenyl Phosphite - Bromine.

Mole Ratio $\text{Br}_2:(\text{C}_6\text{H}_5\text{O})_3\text{P}$	$10^4 \kappa$ $\text{ohm}^{-1} \text{cm}^{-1}$	Mole Ratio $\text{Br}_2:(\text{C}_6\text{H}_5\text{O})_3\text{P}$	$10^4 \kappa$ $\text{ohm}^{-1} \text{cm}^{-1}$
0.00	0.00	1.51	6.32
0.11	0.14	1.73	7.45
0.21	1.17	1.94	8.39
0.32	2.36	2.15	9.04
0.43	3.50	2.36	9.40
0.64	3.89	2.57	9.75
0.86	3.92	2.78	9.91
1.07	3.92	3.00	10.17
1.29	4.86	3.21	10.36

reaction between triphenyl phosphite and bromine involves a series of definite stoichiometric stages. The section A - B shows a steep rise in the conductance up to B which corresponds to a mole ratio of 2 $(\text{C}_6\text{H}_5\text{O})_3\text{P}$ to 1 Br_2 . The solution during this stage of the experiment remained colourless.

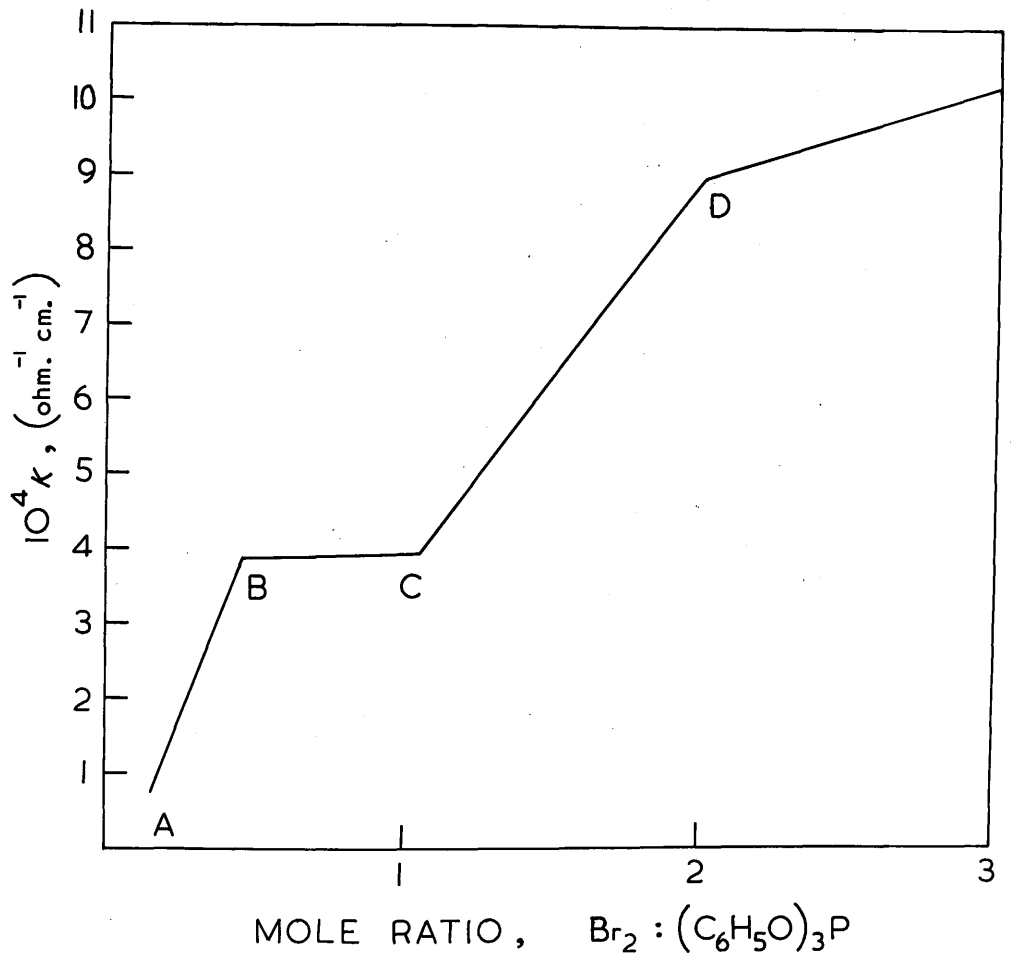
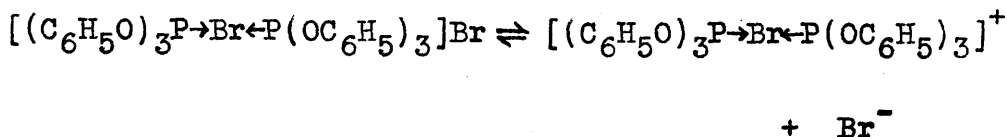
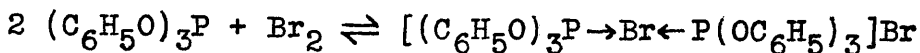

Fig. 20. Conductometric Analysis of the System
Triphenyl Phosphite - Bromine.

It seems likely that at this mole ratio the system may be described in terms of one of the following equilibrium schemes :

(1)...



(2)...

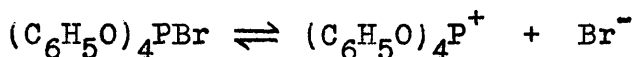
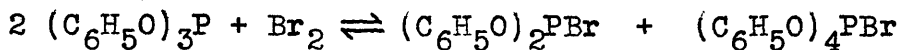

In scheme (1) we encounter the rather unusual occurrence of cationic bromine. This ion is supposedly stabilised by coordination with triphenyl phosphite. The phosphorus atom in triphenyl phosphite possesses a lone pair of 3s electrons in addition to vacant 3d orbitals and this would suggest that the molecules should be capable of coordinating in the above fashion. The analagous ion $[\text{Br} \cdot (\text{NC}_5\text{H}_5)_2]^+$ in-

volving coordination by pyridine has received mention in the literature [73].

The second scheme has been suggested by the results of certain experiments carried out by Rydon [64]. From chlorobenzene solutions containing 2 moles of triphenyl phosphite and 1 mole of bromine it was possible to isolate diphenyl bromophosphite $(C_6H_5O)_2PBr$, and a crystalline compound whose bromine analysis corresponded with that required for the molecule $(C_6H_5O)_4PBr$.

Evidence in favour of scheme (2) was obtained from the result of an ion migration experiment (described later).

Thus in both of these schemes, two molecules of triphenyl phosphite are required to give rise to a pair of ions and the conductance of the system would accordingly rise until the composition $2 (C_6H_5O)_3P + 1 Br_2$ is attained.

Further addition of bromine (B - C, on the graph) led to the appearance of a yellow colour in the solution but to no change in the conductance. The lack

of change in the conductance can be attributed to the absence of a net change in the number of ions in the solution and can be interpreted in terms of the following equations which lead to the formation of triphenoxyphosphorus dibromide at the composition corresponding to C.

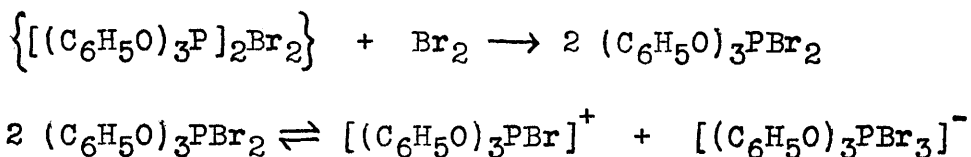

The triphenoxyphosphorus dibromide thus ionises in such a way as to produce a phosphorus containing anion. Had the mode of ionisation been

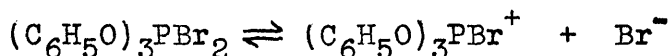

then it is clear that the solution would contain twice as many ions, and the conductance would have continued to rise up to point C. (This point is further investigated in the electrolysis experiment described later).

In terms of the equilibria discussed for the 2:1 ratio, we must regard the formation of the 1:1 ratio

ions as occurring through a series of stages which leads ultimately to both cation and anion possessing three phenoxy groups attached directly to a central phosphorus atom.

A further increase in the bromine - triphenyl phosphite ratio leads to the change C - D, together with an intensification of the colour of the solution. These results are accounted for by the formation of a polybromide ion as shown by the equations :

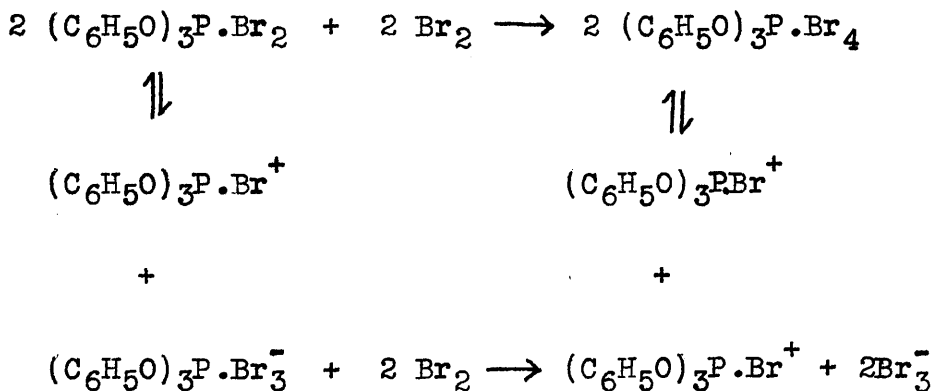

That is a single tribromotriphenoxyphosphate anion breaks up in the presence of additional bromine (2moles) yielding one bromotriphenoxyphosphonium cation and two tribromide ions. The approximate doubling of the conductance when the 1 $(\text{C}_6\text{H}_5\text{O})_3\text{P}$: 2 Br_2 composition

is attained is thus accounted for.

The formation of a tribromide ion in this system accords with the findings of Popov and Skelly [22] who have drawn attention to the strong tendency of halides to form polyhalides in acetonitrile and to the conductance of the resulting solutions.

It has proved possible to isolate this triphenoxy-phosphorus tetrabromide as a yellow crystalline material melting at 105 - 106 °C. Analysis of the substance gave the following results :

	P %	Br %
Found.....	4.94	49.97
	5.01	49.57
	5.08	50.24
	<hr/>	
$C_{18}H_{15}O_3PBr_4$ requires.....	4.92	50.76

The compound is readily hydrolysed to bromine, hydrogen bromide, and triphenyl phosphate.

Other polyhalides of general formula $PX_3 \cdot Y_4$ have been reported. In the phosphorus trichloride - bromine

system Fialkov and Kuz'menko [52] have isolated PCl_3Br_4 , and Forsman and Lipkin [70] have obtained triphenoxyphosphorus tetraiodide, $(\text{C}_6\text{H}_5\text{O})_3\text{PI}_4$, from the triphenyl phosphite - iodine system.

It is perhaps not surprising to find a tendency towards polyhalide formation in this series of compounds considering the presence of anonium type of ion. As a rule polyhalide ions have a greater stability when associated with cations of a comparable size and hence they are formed frequently by halides of the ammonium, phosphonium, etc., and the large alkali metal cations.

The molar conductance of the triphenoxyphosphorus dibromide is as might be expected, lower than that of the dichloride for the same concentration,

$$(\text{C}_6\text{H}_5\text{O})_3\text{PBr}_2, \Delta_m = 35.4 \text{ ohm}^{-1} \text{ cm}^2 \text{ mole}^{-1}, c_m = 0.011$$

The tetrabromide was found to have a molar conductance of $99.5 \text{ ohm}^{-1} \text{ cm}^2 \text{ mole}^{-1}$ at $c_m = 0.0090$.

Summarising, the result of the conductometric analysis of the triphenyl phosphite - bromine system can

be interpreted in terms of three ionisation schemes involving different triphenyl phosphite : bromine ratios as follows —

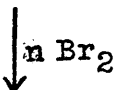
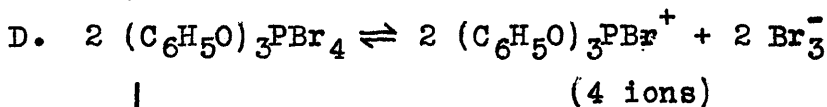
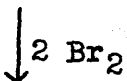
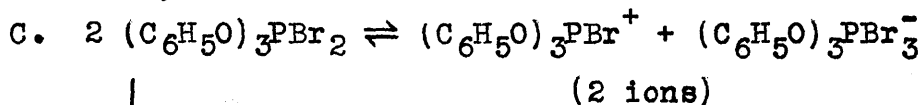
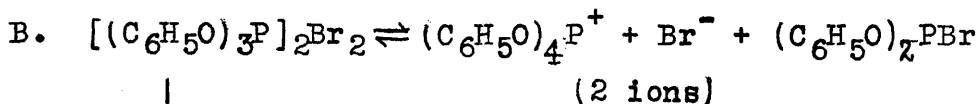
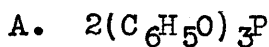

E. Higher bromides

THE ELECTROLYSIS OF TRIPHENOXYPHOSPHORUS DIBROMIDE
IN ACETONITRILE SOLUTION

To confirm the dibromide ionisation scheme, transport experiments were carried out on an acetonitrile solution containing triphenyl phosphite and bromine in the ratio corresponding to triphenoxyphosphorus dibromide.

Ionisation of triphenoxyphosphorus dibromide is likely to comply with one of the following schemes :

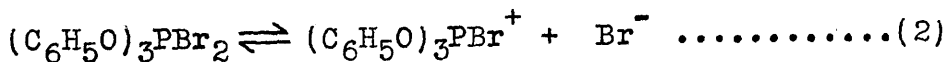
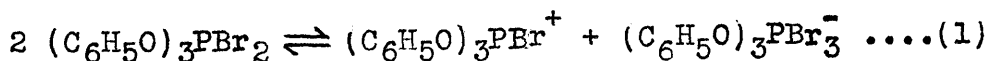

Provided there is no loss of the products from the solution via deposition on the electrodes or evolution as a gas, it should be possible to distinguish between these ionisation schemes by noting the electrolyte concentration changes occurring at the electrodes on electrolysis. If ΔBr and ΔP represent increases in gram-atoms of bromine and phosphorus respectively occurring in the electrode compartments, and t_+ is the transport number of the cation at the concen-

tration used, and x Faradays the quantity of current passed, then for ionisation (1),

$$\text{at cathode, } \Delta Br = x(4t_+ - 3)$$

$$\text{at anode, } \Delta P = x(1 - 2t_+)$$

and for ionisation (2),

$$\text{at cathode, } \Delta Br = x(2t_+ - 1)$$

$$\text{at anode, } \Delta P = -xt_+$$

If $x = 1$ Faraday, the values of ΔBr and ΔP for different values of t_+ are shown in the following tables :

Ionisation (1)

t_+	0	0.1	0.2	0.3	0.4	0.5	0.6	0.7	0.8	0.9	1.0
ΔBr	-3	-2.6	-2.2	-1.8	-1.4	-1.0	-0.6	-0.2	+0.2	+0.6	+1.0
ΔP	1	+0.8	+0.6	+0.4	+0.2	0	-0.2	-0.4	-0.6	-0.8	-1.0

Ionisation (2)

t_+	0	0.1	0.2	0.3	0.4	0.5	0.6	0.7	0.8	0.9	1.0
ΔBr	-1	-0.8	-0.6	-0.4	-0.2	0	+0.2	+0.4	+0.6	+0.8	+1.0
ΔP	0	-0.1	-0.2	-0.3	-0.4	-0.5	-0.6	-0.7	-0.8	-0.9	-1.0

In an experiment the following values of ΔBr were

found for the passage of 1 Faraday of current through a solution of concentration ca. 0.05 M,

$$1. \Delta \text{Br} = -0.64$$

$$2. \Delta \text{Br} = -0.70$$

and the corresponding values of t_+ are,

by ionisation (1), $t_+ = 0.59$ and 0.57

by ionisation (2), $t_+ = 0.18$ and 0.15

Since it is not conceivable for the current to pass through the solution under investigation by a chain transfer mechanism, then direct movement of the ions must be responsible for the passage of current. In such circumstances it is always found that cation and anion carry the current to about the same extent thus making the transport numbers of the ions in the region of 0.5. For this reason it is apparent that triphenyloxyphosphorus dibromide ionises in accordance with scheme (1), i.e.

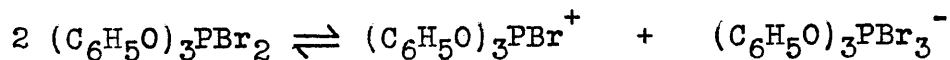

This result is in complete accord with the results of the conductometric analysis of the system triphenyl

phosphite - bromine.

Before the passage of current the solution was yellow in colour, but during electrolysis the cathode solution became colourless, whereas the colour change at the anode was in keeping with the liberation of bromine. The following processes were occurring in the solution at the electrodes —

At cathode :

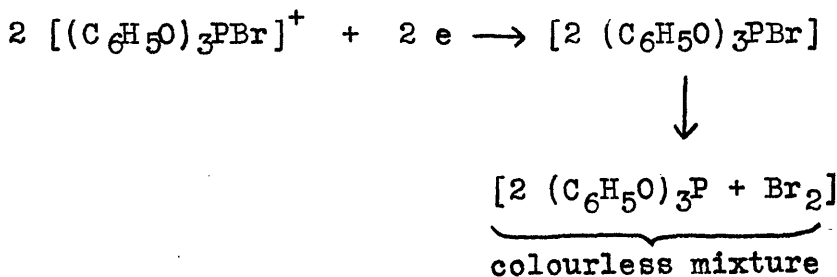

At anode:

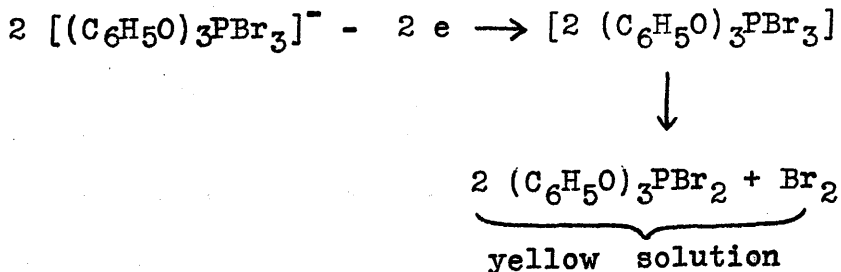

ELECTROLYSIS OF $[(C_6H_5O)_3P]_2Br_2$ IN ACETONITRILE

The nature of the species present in the highly conducting colourless solutions formed by mixing 2 moles of triphenyl phosphite and 1 mole of bromine in acetonitrile, has not yet been determined definitely. It has been suggested that the ionic equilibrium involves cationic bromine stabilised by coordination thus —

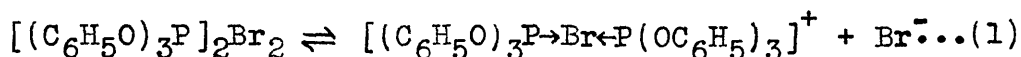

In contrast with this, Rydon [64] has suggested that disproportionation may occur to produce a non-ionic as well as an ionic compound according to the following scheme —

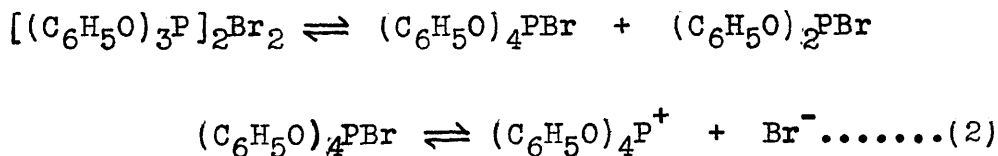

In view of the substantial differences in the structures of the postulated cations, it was thought that the result of a quantitative electrolysis of the system might substantiate one theory or the other.

Electrolysis of the solution results in ion migration and when carried out quantitatively it should be possible to obtain some idea of the structure of the ions present in the solution.

For each of the proposed modes of ionisation it is possible to relate transport numbers and Δ -values. Using the same symbols as before (page 165) then,

for scheme (1),

$$\Delta Br = (2t_+ - 1)x \quad , \text{ at cathode}$$

$$\Delta P = -(2t_+)x \quad , \text{ at anode}$$

and when $x = 1$, the following values are obtained

t_+	0	0.1	0.2	0.3	0.4	0.5	0.6	0.7	0.8	0.9	1.0
ΔBr	-1	-0.8	-0.6	-0.4	-0.2	0	+0.2	+0.4	+0.6	+0.8	+1
ΔP	0	-0.2	-0.4	-0.6	-0.8	-1.0	-1.2	-1.4	-1.6	-1.8	-2

For scheme (2), assuming that diphenyl bromophosphite plays a completely passive rôle during electrolysis,

$$\Delta Br = (t_+ - 1)x \quad , \text{ at cathode}$$

$$\Delta P = -(t_+)x \quad , \text{ at anode}$$

and when $x = 1$, the following set of values is obtain-

ed,

t_+	0	0.1	0.2	0.3	0.4	0.5	0.6	0.7	0.8	0.9	1.0
ΔBr	-1	-0.9	-0.8	-0.7	-0.6	-0.5	-0.4	-0.3	-0.2	-0.1	0
ΔP	0	-0.1	-0.2	-0.3	-0.4	-0.5	-0.6	-0.7	-0.8	-0.9	-1

By applying the experimental values of ΔBr and ΔP to the above sets of figures it is possible to obtain transport number values. Clearly, ΔBr and ΔP will give rise to the same value of t_+ when they are substituted in the expression for the correct ionisation type. In addition it is to be expected that the value of t_+ will be in the region of 0.5.

In an actual experiment, the following values were obtained,

$$\Delta Br = -0.45, -0.66$$

$$\Delta P = -0.24$$

Fitting these results into scheme (1) the following values of t_+ are obtained, 0.27, 0.17, 0.12. And in the case of ionisation (2) the values of t_+ are 0.55, 0.34, 0.24.

On account of the discordance of these results it still remains uncertain which ionisation scheme is the

correct one. The values of t_+ for ionisation (1) are the more consistent set, but the average value (0.19) is much lower than would be expected.

With regard to the mechanism proposed by Rydon, no consideration was given to the possibility that the ionisation of tetraphenoxyphosphorus monobromide might take place in a manner analagous to the ionisation of triphenoxyphosphorus dibromide and produce a phosphorus containing anion. Scheme (2) would have to be rewritten thus :

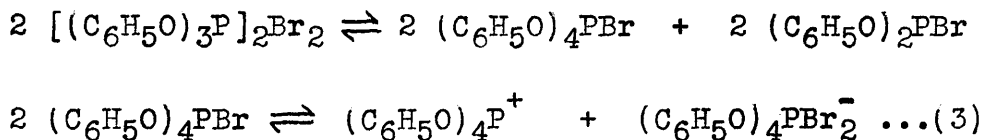

The idea that tetraphenoxyphosphorus monobromide in acetonitrile ionises in this manner receives some support from a study of the system phenol - phosphorus pentabromide - acetonitrile, and this evidence is described later.

However, reconsideration of the results of the conductometric analysis of the triphenyl phosphite - bromine system, necessitates that scheme (3) must be

rejected, for if the system at the $2(\text{C}_6\text{H}_5\text{O})_3\text{P}:\text{lBr}_2$ ratio consisted of —

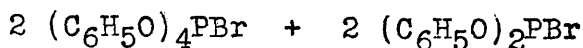

then reaction of these components with additional bromine (up to the 1:1 ratio), would lead to a doubling of the number of ions. This does not fit in with the experimental observations. It is concluded therefore that if present the $(\text{C}_6\text{H}_5\text{O})_4\text{PBr}$ does not (under the existing conditions) ionise to $(\text{C}_6\text{H}_5\text{O})_4\text{P}^+$ and $(\text{C}_6\text{H}_5\text{O})_4\text{PBr}_2^-$.

There now remains the possibility that the diphenyl bromophosphite formed during disproportionation of $[(\text{C}_6\text{H}_5\text{O})_3\text{P}]_2\text{Br}_2$ does play an active part during electrolysis. It is conceivable that the following might occur —

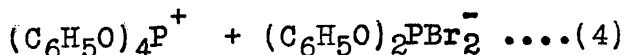
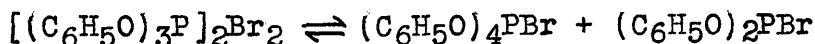

That is the diphenyl bromophosphite unites with the

simple bromide ion to form a four-coordinate complex anion with phosphorus at its centre.

Although there may be certain objections to the anion $(C_6H_5O)_2PBr_2^-$, it is interesting to calculate the $\Delta Br - t_+$, and $\Delta P - t_+$ relationships for this system [by inspection it is seen that the relationships between ΔBr , ΔP and t_+ are identical for schemes (3) and (4)].

Scheme 4, $\Delta Br = (2t_+ - 2)x$, at cathode

$\Delta P = (1 - 2t_+)x$, at anode

and when $x = 1$,

t_+	0	0.1	0.2	0.3	0.4	0.5	0.6	0.7	0.8	0.9	1.0
ΔBr	-2	-1.8	-1.6	-1.4	-1.2	-1.0	-0.8	-0.6	-0.4	-0.2	0
ΔP	1	+0.8	+0.6	+0.4	+0.2	0	-0.2	-0.4	-0.6	-0.8	-1

Application of the experimentally determined values of ΔBr and ΔP give values of t_+ equal to 0.77, 0.67, 0.62. That is, a consistent set of transport number values is obtained, the average value being 0.69.

These results suggest that the equilibrium,

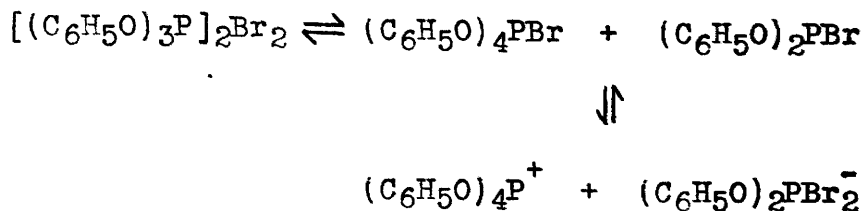

describes the system more closely than any of the other schemes considered.

Although it seems likely, it is not a necessary condition that $(\text{C}_6\text{H}_5\text{O})_4\text{PBr}$ and $(\text{C}_6\text{H}_5\text{O})_2\text{PBr}$ must be formed in the solution before the ions $(\text{C}_6\text{H}_5\text{O})_4\text{P}^+$ and $(\text{C}_6\text{H}_5\text{O})_2\text{PBr}_2^-$ are produced, in spite of the fact that $(\text{C}_6\text{H}_5\text{O})_4\text{PBr}$ and $(\text{C}_6\text{H}_5\text{O})_2\text{PBr}$ can be isolated from a solution (in chlorobenzene) containing triphenyl phosphite and bromine in the ratio 2:1. It is not unlikely that the conditions under which isolation is carried out might induce structural changes in the compounds. To quote Kosolapoff [67b] in a discussion of systems of phosphites and halophosphites,

"In many respects the mixture may be regarded as a mobile equilibrium system that may shift during the course of isolation of the products....."

Thus care must be taken when the structure of the components of solutions of these phosphorus compounds

is deduced from the structure of isolated products.

The ions $(C_6H_5O)_4P^+$ and $(C_6H_5O)_2PBr_2^-$ might well arise directly from the breakdown of an intermediate complex such as $[(C_6H_5O)_3P \rightarrow Br \leftarrow P(OC_6H_5)_3]^+ Br^-$.

There is some evidence that the production of the final ions does occur through an ionic intermediate. In the conductometric titration experiment (p.155) it was found that after each addition of bromine solution to triphenyl phosphite solution up to the 0.5 mole ratio, the conductance, after a steep initial rise, fell slightly to a steady value.

The scheme of ionisation proposed for the solution of composition $[(C_6H_5O)_3P]_2Br_2$ is seen to contain the unfamiliar PX_4^- type of ion. Analogous ions involving the heavier Group V elements are known. It has recently been shown [74] that the 1:1 addition compound formed between tetramethylammonium chloride and arsenic trichloride contains the tetrachloroarsenite anion $[AsCl_4^-]$. Similarly antimony and bismuth may be the centre of a four coordinate anion - $M^I[SbCl_4]$, $M^I[BiCl_4]$.

In these anions the outer electronic structure is presumably $(2) \mid (\underline{6}) (\underline{2})$, which involves a pair of non-bonded valency electrons. Although the occurrence of such structures is quite well established in the heavier Group V neighbours of phosphorus, perhaps the only known compounds of the latter element with a similar electronic configuration, are those formed between aromatic phosphine oxides and alkali metals [75] e.g. $[(C_6H_5)_3PO]^{2-} 2K^+$. The phosphorus atom in the phosphyl ion is clearly isoelectronic with the phosphorus in the above postulated $[(C_6H_5O)_2PBr_2]^-$ ion.

During the electrolysis, minute bubbles of an unidentified gas were observed to form at the cathode. A yellowish-white solid was deposited at the cathode, and at the anode the solution turned yellow in colour. (presumably due to the formation of bromine).

The following is a tentative scheme of the electrode processes —

At cathode,

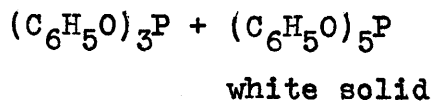
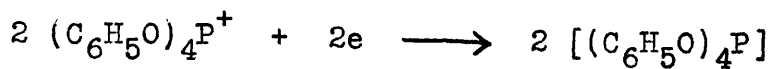

At anode,

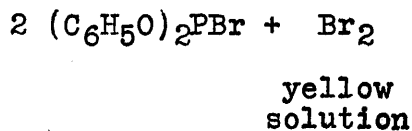
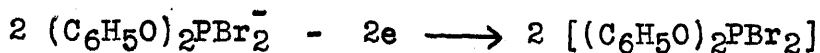

The evolution of a gas insoluble in acetonitrile is not explained.

REACTION BETWEEN PHENOL AND PHOSPHORUS PENTABROMIDE

An alternative approach to the study of phenoxy-phosphorus bromides utilises the other method of preparation, from phosphorus pentabromide and phenol :

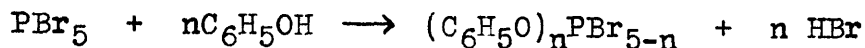

This reaction was studied as it occurs in an acetonitrile medium. Phenol in acetonitrile was added in stages to phosphorus pentabromide in acetonitrile and the changing conductance of the mixture noted. Phenol itself has a negligible molar conductance in this solvent ($\Lambda_m = 0.02 \text{ ohm}^{-1} \text{ cm}^2 \text{ mole}^{-1}$, $c_m = 0.05$) hence any significant change in the conductance of the phosphorus pentabromide solution must be due to interaction of the phosphorus halide and phenol.

The results of the experiment are recorded in Table 21 and shown graphically in Fig. 21.

The specific conductance - mole ratio (n) curve shows distinct inflections at whole number ratios from 1 to 4. The existence of the complexes —

Table 21. Conductometric Titration of Phenol and Phosphorus Pentabromide in Acetonitrile.

Mole Ratio $C_6H_5OH:PBr_5$	$10^4 \kappa$ $ohm^{-1} cm^{-1}$	Mole Ratio $C_6H_5OH:PBr_5$	$10^4 \kappa$ $ohm^{-1} cm^{-1}$
0.00	7.29	3.14	7.94
0.20	17.49	3.34	8.10
0.39	23.49	3.54	8.13
0.58	22.03	3.72	8.18
0.78	18.14	3.91	8.26
0.97	15.22	4.10	8.26
1.17	13.28	4.29	8.33
1.36	11.66	4.49	8.33
1.56	10.43	4.68	8.33
1.76	9.23	4.88	8.42
1.96	8.42	5.07	8.42
2.16	8.10	5.26	8.42
2.36	7.78	5.47	8.42
2.56	7.94	5.66	8.42
2.75	7.78	5.85	8.42
2.95	7.97		

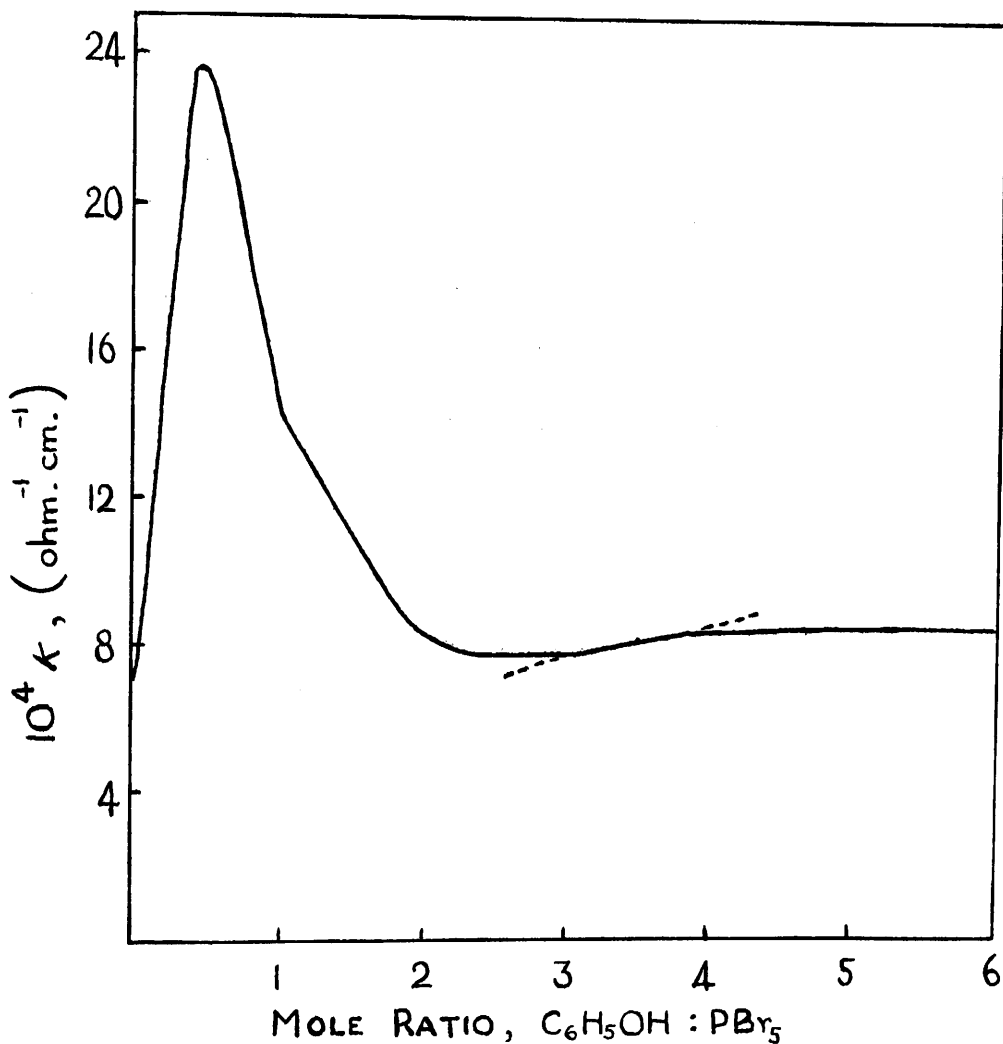
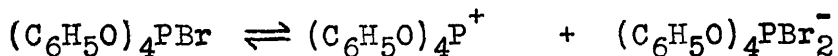
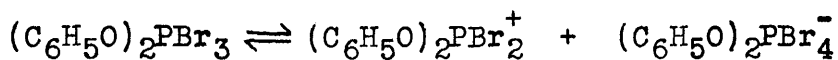

Fig. 21. Conductometric Titration of Phenol and Phosphorus Pentabromide in Acetonitrile.

$(C_6H_5O)PBr_4, \dots, (C_6H_5O)_4PBr$, at these ratios is inferred. In addition the value of κ is found to be roughly the same at each of the ratios 0, 2, 3, 4. This seems to indicate that there is no great variation in the number of ions present. Since phosphorus pentabromide and triphenoxyphosphorus dibromide have been shown to produce the ions PBr_4^+ , PBr_6^- and $(C_6H_5O)_3PBr^+$, $(C_6H_5O)_3PBr_3^-$ respectively, then it follows that the compounds $(C_6H_5O)_2PBr_3$ and $(C_6H_5O)_4PBr$ ionise in such a way that a phosphorus-containing anion is produced. For example :



The slight changes in conductance are therefore due to the change in the structure of the ions when Br is replaced by C_6H_5O . Conductance values at the various ratios are shown in Table 22.

Values of Λ_m at mole ratios 0 and 3, are consistent with the values previously determined for phosphorus pentabromide and triphenoxyphosphorus di-

Table 22. Conductance Values in the System C₆H₅OH - PBr₅ - CH₃CN.

Mole Ratio C ₆ H ₅ OH:PBr ₅	10 ⁴ κ ohm ⁻¹ cm. ⁻¹	c _m mole.litre ⁻¹	Λ _m ohm ⁻¹ cm. ² litre ⁻¹
0.0	5.7	0.07207	7.86
0.5	23.6	0.06585	35.84
1.0	13.2	0.06061	21.78
2.0	7.9	0.05229	15.11
3.0	7.9	0.04597	17.18
4.0	8.4	0.04102	20.47

bromide respectively.

The value of κ at mole ratio 1 (about twice the value of κ at mole ratios 2, 3, 4.) might indicate that the complex formed at this stage is ionising as a monomer, for example

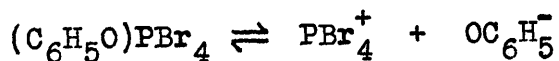

or alternatively

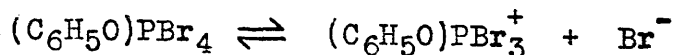

The former of these is perhaps more likely on account of the known stability of the PBr_4^+ ion in acetonitrile and the relatively large size of the phenoxide ion. In either case, addition of bromine accompanied by the formation of a phosphorus containing anion, would result in a marked drop in the conductance of the solution.

The explanation of the conductance maximum at the mole ratio 0.5 is not immediately obvious, but is conceivably due to the participation of either the cation or the anion of phosphorus pentabromide in the reaction with phenol.

Hydrolysis and alcoholysis of non-metallic halides is usually represented as occurring through the intermediate formation of a complex in which the water or alcohol molecule is coordinated to the non-metal atom, through donation of electrons from the oxygen atom. In the case of phosphorus pentabromide, the attack would presumably be on the cation PBr_4^+ to produce the

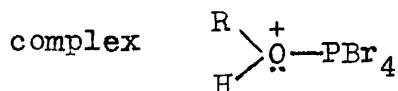

Now considering the reaction of phosphorus pentabromide with phenol, attention must be paid to the distribution of charge in the phenol molecule. By virtue of a mesomeric +M effect involving the benzene ring, the oxygen atom must be more positive than it is in the alcohols, and consequently less able to donate electrons. This together with a possible steric effect seems to suggest that the phenol is unlikely to react with phosphorus pentabromide by first of all forming a complex of the type :

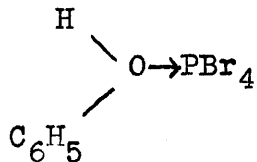

The attack would therefore involve the anion PBr_6^- and the following scheme is suggested :

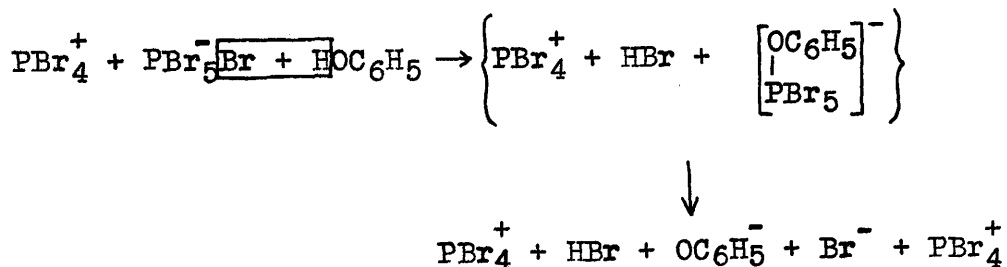

The stoichiometry of this reaction coincides with a

mole ratio of 0.5 . Further addition of phenol till the mole ratio is 1.0 is considered to produce the following change.

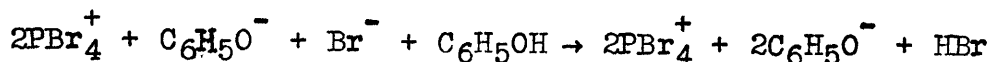

In these systems it is assumed throughout that the hydrogen bromide is bound non-ionically as the iminobromide $\text{CH}_3\text{CBr}=\text{NH}$.

The colour of the solution which was originally yellow, became colourless at a mole ratio between 3 and 4. This observation is in accord with our knowledge of the complexes formed at these stoichiometric ratios — $(\text{C}_6\text{H}_5\text{O})_3\text{PBr}_2$ is a yellow solid, and $(\text{C}_6\text{H}_5\text{O})_4\text{PBr}$ [64] is white.

These results show that in acetonitrile, the replacement of Br by $\text{C}_6\text{H}_5\text{O}$ occurs quite readily to yield the series of phenoxyphosphorus bromides. The composition of the product depends only on the ratio of the two reactants.

CONDUCTOMETRIC ANALYSIS OF THE SYSTEM TRIPHENYL
PHOSPHITE - IODINE

The literature contains contradictory evidence about the existence of a triphenoxyphosphorus di-iodide. Forsman and Lipkin [70] studied the triphenyl phosphite - iodine system in some detail but reported that a 1:1 addition compound could not be obtained. Rydon and his school [61] on the other hand have reported that they obtained triphenoxyphosphorus di-iodide as a crystalline solid.

This present investigation is designed to relate the behaviour of the triphenyl phosphite - iodine system with that of the better known systems involving chlorine and bromine.

Conductometric titration of triphenyl phosphite with iodine in acetonitrile gave the results shown in Table 23 and Fig. 22. (note: for iodine in acetonitrile, $\Lambda_m = 0.18 \text{ ohm}^{-1} \text{ cm}^2 \text{ mole}^{-1}$ at $c_m = 0.0322$).

The form of the graph shows that the system is quite different from that of bromine - triphenyl

Table 23. Conductometric Analysis of the System
Triphenyl phosphite - Iodine.

Mole Ratio $I_2:(C_6H_5O)_3P$	$10^4 \kappa$ $ohm^{-1} cm^{-1}$	Mole Ratio $I_2:(C_6H_5O)_3P$	$10^4 \kappa$ $ohm^{-1} cm^{-1}$
0.06	1.04	0.76	4.54
0.17	1.62	0.88	5.05
0.29	1.88	1.00	5.48
0.35	2.11	1.11	5.83
0.41	2.43	1.23	6.12
0.53	3.00	1.34	6.42
0.65	3.89		

phosphite. As in the latter system, an inflection of the graph occurs at the mole ratio 0.5, and in this case the solution at this stage is coloured yellow-brown. A di-iodide, stable in solution, is also clearly indicated. The equivalent conductance of the di-iodide is $46.55 ohm^{-1} cm^2 mole^{-1}$ at $c_m = 0.0117$.

Thus it is seen that in the triphenyl phosphite - iodine system, the value of Λ_m (and κ) is anomalously

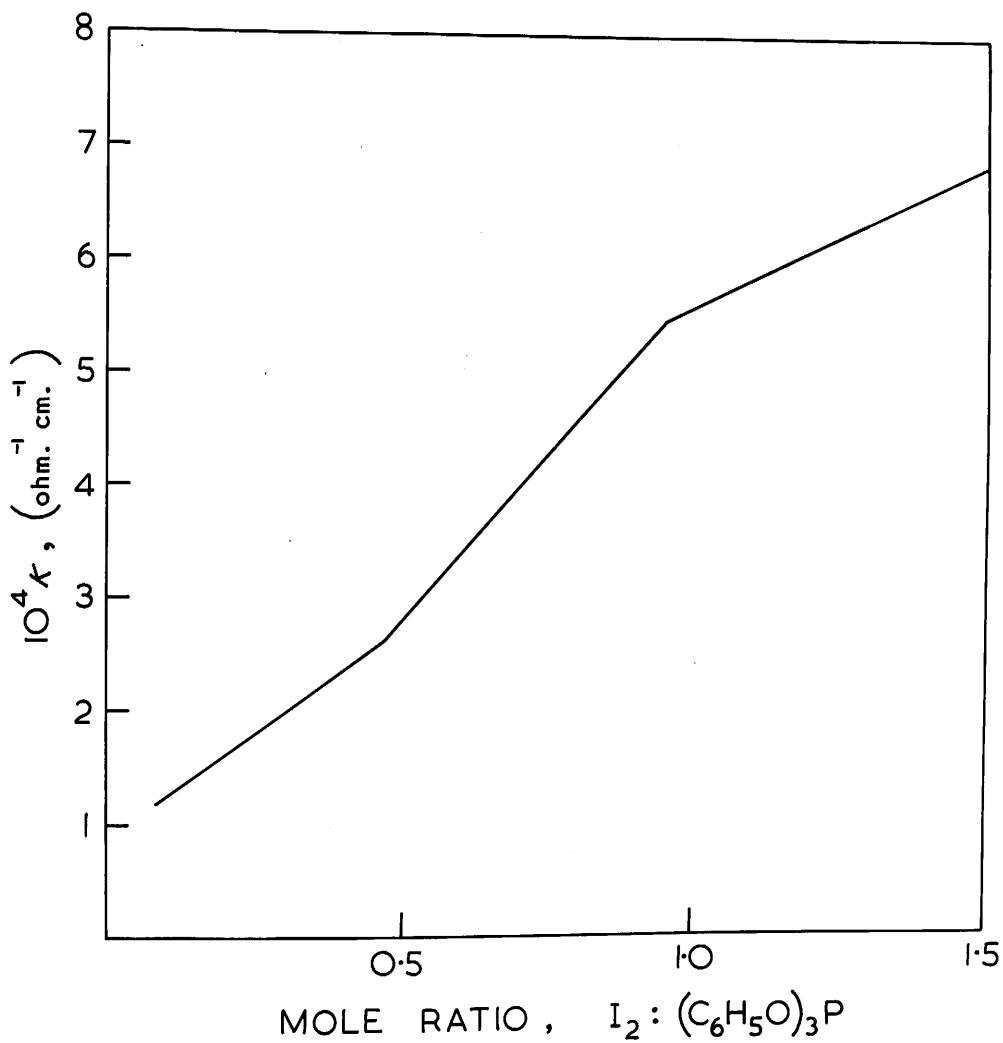
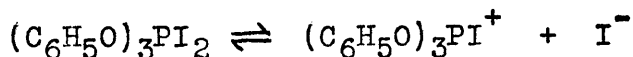

Fig. 22. Conductometric Analysis of the System
Triphenyl Phosphite - Iodine.

high at the 1:1 ratio, compared with the values obtained in the triphenyl phosphite - bromine ($\Lambda_m = 35.4$, $c_m = 0.0110$) and triphenyl phosphite - chlorine ($\Lambda_m = 100.5$, $c_m = 0.0117$) systems. It is therefore concluded that the iodine - triphenyl phosphite system undergoes a different series of ionisations. It is reasonable to suppose that for steric reasons a phosphorus-containing anion such as $(C_6H_5O)_3PI_3^-$ would be very unlikely to occur, and this being so the triphenoxyphosphorus di-iodide would ionise in the monomeric form -



On this basis the results can be interpreted according to the following scheme :-

Mole Ratio 0 - 0.5

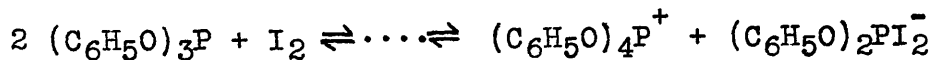

Mole Ratio 0.5 - 1.0

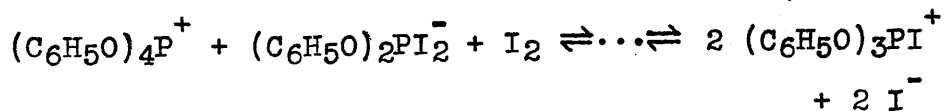

Mole Ratio 1.0 →

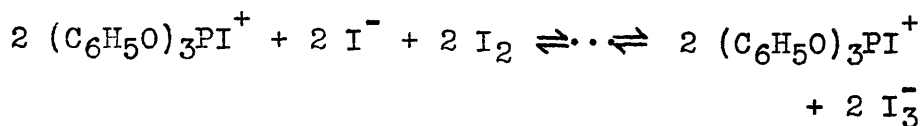

By this scheme the number of ions continuously increases up to the 1:1 ratio, and at this point there are theoretically twice the number of ions present than there would be if the anion was a tri-iodotriphenoxyphosphate ion.

Triphenoxyphosphorus tetraiodide which comes into the above scheme as iodotriphenoxyphosphonium triiodide has been isolated by Forsman and Lipkin [70] who also obtained triphenoxyphosphorus enneaiodide. These authors also considered the cation $(\text{C}_6\text{H}_5\text{O})_3\text{PI}^+$ to be present. A preliminary x-ray crystallographic investigation of triphenoxyphosphorus tetraiodide has afforded results which are in keeping with a crystal built up of $(\text{C}_6\text{H}_5\text{O})_3\text{PI}^+$ and I_3^- units [76].

These results constitute useful corroborative evidence for the work on triphenoxyphosphorus tetrabromide described earlier in Part III.

EXPERIMENTAL PART

MATERIALS.

Several of the chemical compounds used in this part of the thesis were also used in earlier parts, and a detailed description of their purification is to be found there. These include the purification of acetonitrile, bromine, and phosphorus pentabromide. Compounds encountered for the first time are as follows :

Hydrogen Chloride.

The hydrogen chloride was prepared by the action of concentrated sulphuric acid on concentrated hydrochloric acid in a Tucker generator [77], which was attached to a U-tube trap with a constriction and joint as shown in the following sketch :

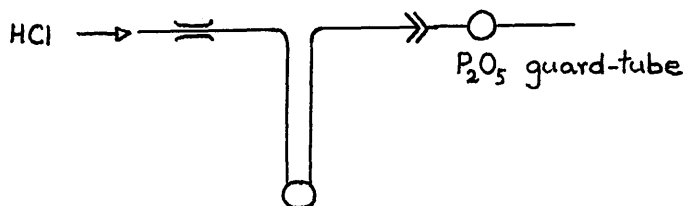

The phosphorus pentoxide guard-tube prevents the ingress of atmospheric moisture. Hydrogen chloride was allowed to pass through the trap until all the air had been swept out. The hydrogen chloride was then condensed in the trap by surrounding it with liquid oxygen, and when about half full the constriction was sealed. The trap (still immersed in the cooling bath) was then attached, by way of the ground glass joint, to the fractionation line of the vacuum system. It then became trap A in Fig. 23. Each section of the vacuum system was evacuated and purification of the hydrogen chloride was carried out in the following manner. Traps A and C were cooled in liquid oxygen and trap B in an acetone - solid carbon dioxide mixture (ca. -85°C). Taps T_1 , T_2 , and T_3 were closed and taps T_4 and T_5 opened. The hydrogen chloride in trap A was allowed to warm up by removing the coolant, and pure hydrogen chloride began to condense in trap C. Trap B served to protect trap C from any water vapour which may still have been present in the distilling hydrogen chloride. When an adequate amount of the pure compound had condensed in trap C, traps A and B were re-cooled by their

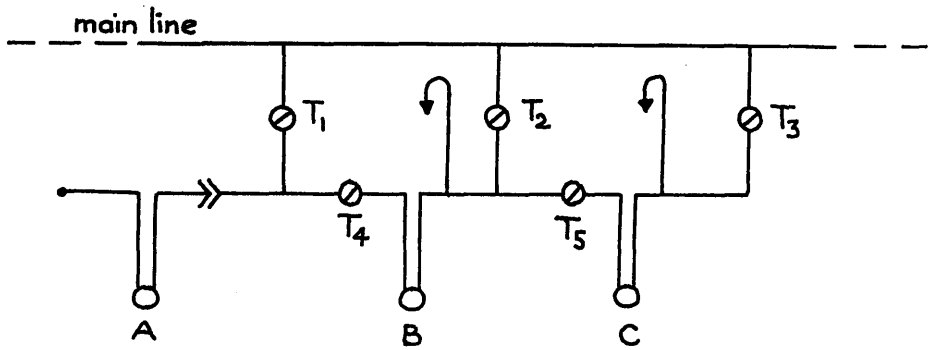

Fig. 23. Apparatus for the purification of hydrogen chloride.

respective cooling baths. Taps T_4 and T_5 were then closed. The contents of traps A and B were allowed to warm up, and by opening taps T_1 and T_2 , these unwanted materials were transferred to the general sludge trap of the vacuum system. The pure hydrogen chloride was stored in trap C (cooled to liquid oxygen temperature) until required for use.

Triphenyl Phosphate.

This material was obtained from Professor H.N. Rydon. It was recrystallised from aqueous alcohol and dried in a vacuum desiccator. The product consisted of white, fine needles of melting point 47 - 49 °C.

Triphenoxyphosphorus Dichloride.

This compound was received from Professor Rydon. The analytical figures obtained were Cl, 18.90, 18.95 % (Calculated for $C_{18}H_{15}O_3PCl_2$: Cl, 18.61 %). When it was suspected that slight hydrolysis of a sample had taken place, the material was rinsed with anhydrous ether

which dissolves the hydrolysis products, leaving the triphenoxyphosphorus dichloride unaffected.

Triphenyl Phosphite.

Commercial triphenyl phosphite (gifted by Messrs. Albright and Wilson) was purified by fractional distillation under reduced pressure. The boiling point was 180 °C at about 0.5 mm. pressure.

Iodine.

Commercial (Whiffen) resublimed iodine was used without further purification.

Phenol.

AnalaR grade phenol (M. and B.) was powdered and resublimed in a vacuum, from 50 °C on to a cold finger at -80 °C.

CONDUCTANCE EXPERIMENTS.

These were carried out in the pipette cell described in Part I of the thesis. The cell was immersed in a water thermostat at 25°C and conductance values were obtained using the Mullard Conductance Bridge.

Conductance of Hydrogen Chloride in Acetonitrile.

A solution of approximately known concentration was prepared in the vacuum system. Referring back to Fig. 23, p.194, the main line was first of all shut off from the pumping unit. Then trap C, containing the hydrogen chloride was allowed to warm up very slowly, and by opening tap T₃ carefully, sufficient gaseous hydrogen chloride was admitted to the main-line section until the pressure in it was equal to a predetermined value (calculated from the weight of hydrogen chloride required, and the known capacity of the main-line section). Tap T₃ was then closed and trap C recooled.

The hydrogen chloride was then condensed from the main-line on to an approximately known amount of aceto-

nitrile contained in a flask in the conductance section of the system. Solution was assisted by magnetic stirring after the acetonitrile had melted. The solution was then transferred to the conductance cell and its conductance measured. The molar concentration of the solution was found by estimating the chloride ion content of measured portions of the solution (Volhard's method).

Conductances of Triphenyl Phosphate, Phenol, and Iodine in Acetonitrile.

Known solutions of these substances were prepared by weight, and their conductances determined.

Conductance of Triphenoxyphosphorus Dichloride in Acetonitrile.

Solutions of this compound were prepared in the dry-box. The conductance was then measured and finally the concentration was found by chemical analysis. Measured samples of the solutions were hydrolysed by sodium hydroxide solution and the halide ion was estimated by Volhard's method.

CONDUCTOMETRIC ANALYSES.

The following conductometric titrations were carried out in the specially designed apparatus described in Appendix 3. In every case, the titration medium was acetonitrile.

Triphenyl Phosphate versus Hydrogen Chloride.

The triphenyl phosphate solution of known concentration was prepared by weight. The solution of hydrogen chloride in acetonitrile was prepared in the same manner as described in the section on conductance experiments. Its concentration was determined by analysing a measured sample for chloride ion. The triphenyl phosphate solution was run into the hydrogen chloride solution and the change in conductance of the latter measured.

Bromine versus Triphenyl Phosphite.

The triphenyl phosphite solution was prepared by adding a known weight of the compound (from a weight-pipette) to a known weight of acetonitrile. The bromine solution was made by breaking a bulb-ampoule containing a known weight of bromine, under a known weight of acetonitrile. This solution was employed

as the titrant in the analysis.

Iodine versus Triphenyl Phosphite.

Each solution was prepared by weight and as before the halogen solution was the titrant.

Phenol versus Phosphorus Pentabromide.

Both of the solutions were prepared by adding a known weight of the solute to a known weight of acetonitrile. The phenol solution was run into the phosphorus pentabromide solution.

ELECTROLYSIS EXPERIMENTS.

Electrolysis of acetonitrile solutions containing triphenyl phosphite and bromine in various ratios.

Solutions for electrolysis were prepared by the controlled mixing of standard solutions of bromine and triphenyl phosphite in acetonitrile (the separate solutions being themselves prepared by the methods previously described). The electrolysis was carried out in a modified Hittorf type of cell which is described in detail in Appendix 4. The triphenyl phosph-

ite solution was initially prepared in flask B of the apparatus, and the requisite volume of the bromine solution added to it from the burette of the conductometric titration apparatus.

After electrolysis the contents of the middle, cathode, and anode compartments were removed in standard flasks (100 cc.) for analysis. Distilled water was added to each solution until the water insoluble product of hydrolysis (triphenyl phosphate) was just about to come out of solution. The solutions were then made up to the mark with an acetone-water mixture. Aliquot portions of these solutions were then analysed for bromine and phosphorus.

Bromine Estimation :

A portion (20 cc.) of each solution was taken and added to N NaOH (50 cc.) in a conical flask. This was boiled for 10 min. and neutralised with dilute nitric acid. 5 N nitric acid (5 cc.) was then added in excess and the bromide ion estimated by Volhard's method.

Phosphorus Estimation :

A 20 cc. portion of the aqueous-acetone solution was evaporated very slowly (at 25°C) to dryness. The residue consisted of white crystalline needles and it was necessary to oxidise this material to ensure that the phosphorus was present as phosphate ion. For this a modification of the procedure described by Marie [78] was employed. The amount of phosphorus to be estimated was about 0.0031 g.

AnalaR nitric acid (35 cc.) was added to the phosphorus-containing material and the mixture heated to just below the boiling point. AnalaR potassium permanganate (3 g.) was added over a period of 30 min., and following this the mixture was heated for a further hour (constant swirling was necessary to prevent bumping). The mixture was allowed to cool and the precipitated manganese dioxide dissolved by the dropwise addition of a 10 % solution of sodium nitrite. The solution (yellow) was then heated to remove oxides of nitrogen (solution finally colourless) and after cooling, some water (25 cc.) was added, followed by

ammonium hydroxide till the solution was slightly alkaline to litmus (a white precipitate of manganous hydroxide was formed). Nitric acid was then added until the manganous hydroxide dissolved and 5 cc. in excess were used. The phosphorus was then ready for precipitation as ammonium phosphomolybdate.

To the solution ammonium nitrate (10 g.) was added and the solution heated to 45°C. Ammonium molybdate solution (50 cc., containing 0.5 g. solute, i.e. a twofold excess) was heated to the same temperature and added in drops to the phosphate solution. Stirring was carried out and continued for 10 min. The precipitate was allowed to stand for 30 min., and then filtered through a No. 40 Whatman filter paper. The precipitate was washed by decantation three times with 5 % ammonium nitrate solution, the bulk of the precipitate being retained in the original beaker. The ammonium phosphomolybdate was taken up in a solution prepared by dissolving citric acid (0.5 g.) and concentrated ammonia solution (7cc.) in water (15 cc.). The apparatus was finally washed with small volumes of dilute ammonia (1:20) followed by hot water, then

hot dilute hydrochloric acid (1:20), hot water and finally with dilute ammonia and hot water (the total volume of the solution at this stage was about 200 cc.) The next step was to precipitate the phosphate as magnesium ammonium phosphate.

The ammoniacal solution was made slightly acid to methyl red with dilute hydrochloric acid solution. Magnesia mixture (10 cc., containing 0.5 g. magnesium chloride hexahydrate) was added dropwise, and ammonium hydroxide solution (1:1) was then added with stirring until the solution was alkaline. 5 cc. in excess were added and the precipitate allowed to stand over-night. Filtration through a No. 42 filter paper was then carried out and the precipitate was washed thoroughly with a 1:20 solution of ammonia. The precipitate was dissolved in warm 1:4 hydrochloric acid solution (the volume at this stage was about 100 cc.), magnesia mixture (5 cc.) added, and the magnesium ammonium phosphate precipitated as before. After standing over-night the solution was filtered through a porcelain crucible (Royal Worcester O/4) of known weight. The precipitate was washed with a 1:20

ammonia solution until free from chloride ion. The crucible was then dried in an air oven at 120°C and finally the magnesium ammonium phosphate was ignited to magnesium pyrophosphate in a muffle furnace at 900°C.

PREPARATION AND ANALYSIS OF TRIPHENOXYPHOSPHORUS
TETRABROMIDE.

An excess of bromine was added to triphenyl phosphite (0.005 mole) in ether solution. This produced a heterogeneous precipitate accompanied by the evolution of heat. The solvent containing excess bromine was decanted off. The precipitate was dissolved in acetonitrile in which it is very soluble. Ether was then added until a yellow crystalline precipitate was obtained. The solvent was decanted and the crystals washed by decantation with ether until the ether was almost colourless. After the final decantation the residual solvent was removed under slightly reduced pressure. The product was a very hygroscopic yellow crystalline solid of melting point (sealed tube), 105 - 106 °C. The yield

was about 60 %.

Analysis was accomplished by hydrolysing a known weight of the solid with sodium hydroxide solution. This was carried out in a closed system to avoid the loss of hydrogen bromide. The resulting solution was yellow and contained an insoluble white solid. The bromine was reduced to bromide by passing sulphur dioxide through the solution. The solid was then removed by filtration and the solution acidified with dilute nitric acid. Carbon dioxide was then bubbled through the boiling solution to expel excess sulphur dioxide. After cooling, the bromide ion content of the solution was determined by Volhard's method.

The white solid produced on hydrolysis appears to be triphenyl phosphate. The melting point of the substance was found to be 48.0 - 49.5 °C. An authentic specimen of triphenyl phosphate melted at 48.0 - 49.5°C and determination of the mixed melting point resulted in a value of 48.5 - 49.5 °C.

Phosphorus analysis was done after oxidation of the substance with concentrated nitric acid and pot-

assium permanganate (as described in the section on electrolysis experiments, p.202). After an initial precipitation as ammonium phosphomolybdate the phosphate was precipitated as magnesium ammonium phosphate and finally ignited to the pyrophosphate which was weighed.

The following

... of ...
... of ...
... in the ...
... large ...
... on ...
... attention ...

APPENDICES

... the ...
... and the ...
... the box was ...
... gloves which were ...
... The introduction ...
... from the outside ...
... a transfer-box which possessed a ...

APPENDIX 1

THE DRY-BOX

At all times during the research the transfer of easily hydrolysable materials was carried out in the Dry-box. This piece of equipment consisted of a large box (capacity ca. 100 litres) which contained an efficient desiccating agent (phosphorus pentoxide or silica gel). In addition to this the pressure inside the box was made slightly greater than atmospheric by passing a stream of dry air through the box.

The top surface of the box was constructed of perspex and the handling of apparatus and materials inside the box was made possible through a pair of plastic gloves which were sealed in with the wall of the box. The introduction of apparatus etc. to the box from the outside and vice versa was achieved through a transfer-box which possessed a double-door system.

The interior of the box was therefore isolated from the external atmosphere, and the intrusion of atmos-

pheric moisture was impossible. In this way hygroscopic compounds could be handled in a dry atmosphere without hydrolysing.

The atmosphere of the apparatus used by the chemists for the study of atmospheric moisture, was therefore not used to a large extent.

A schematic diagram of the vacuum system is shown in Fig. 24. It was constructed of seven sub-sections essentially of a pumping unit connected to a main line from which various sub-sections branched off. These sub-sections receive their description elsewhere in the thesis.

The pumping unit was made up of an Edwards' rotary diffusion pump (Type 1 H 1) backed by an Edwards' rotary vacuum pump (Type 5H 1). It was protected from condensable vapours by an

APPENDIX 2

THE VACUUM SYSTEM

The use of a vacuum system presents a very convenient method of handling compounds out of contact with the atmosphere. Thus in the present work, in which many of the compounds used hydrolyse in the presence of atmospheric moisture, vacuum technique was used to a large extent.

A schematic diagram of the vacuum system is set out in Fig. 24. It was constructed of Pyrex glass and consists essentially of a pumping unit connected to a main line from which various subsidiary sections branched off. These sub-sections receive more detailed description elsewhere in the thesis.

The pumping unit was made up of an Edward's mercury diffusion pump (Type 1 M 1) backed by a 'Metrovac' rotary vacuum pump (Type SR 2). The pumps were protected from condensable vapours by means of two removable liquid air-cooled traps. An estimate of the pressure attained in the pumping section was

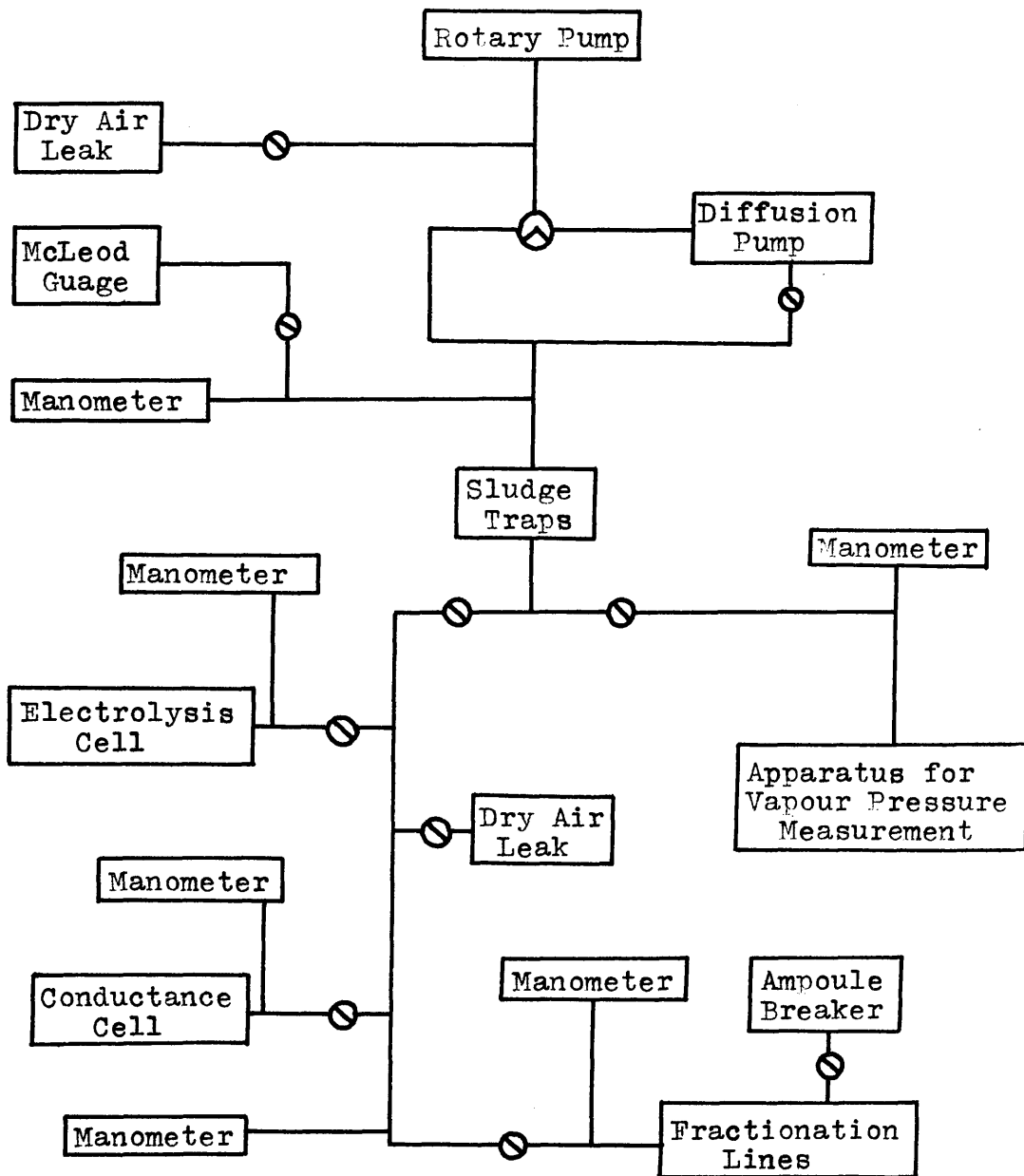

Fig. 24. Schematic Diagram of the Vacuum System.

obtained from the McLeod gauge. Each other section was provided with a manometer for the semi-quantitative determination of pressure.

Dry air could be admitted to the system by way of several inlets, and the introduction of compounds was made through standard joints distributed at several points in the apparatus.

Vacuum taps were used throughout the system and these were generally lubricated with Apiezon M grease. When the compounds being used were unstable in the presence of Apiezon, Florube W grease was used in its place.

Volume calibration of any particular section of the apparatus was effected by expansion of a known volume of carbon dioxide at known pressure.

APPENDIX 3

CONDUCTOMETRIC TITRATION APPARATUS

Physico-chemical investigation of solutions of non-metallic halides is often rendered very difficult on account of the extreme sensitivity of the halides to traces of moisture. The apparatus illustrated in Fig. 25 was designed in order that continuous conductometric titration of anhydrous solutions could be carried out on a small scale under conditions which would prevent their deterioration by contact with atmospheric humidity. By means of this apparatus it has been possible to make a reliable study of complex formation by certain non-metallic halides ; for example, the addition compounds formed between phosphorus halides and halides of Group IV metals. These reactions have been studied in indifferent solvents such as acetonitrile and nitrobenzene. The apparatus has the additional advantage that the solutions do not come into direct contact with tap lubricants.

The procedure employed in a conductometric titration was as follows. Before use the apparatus was

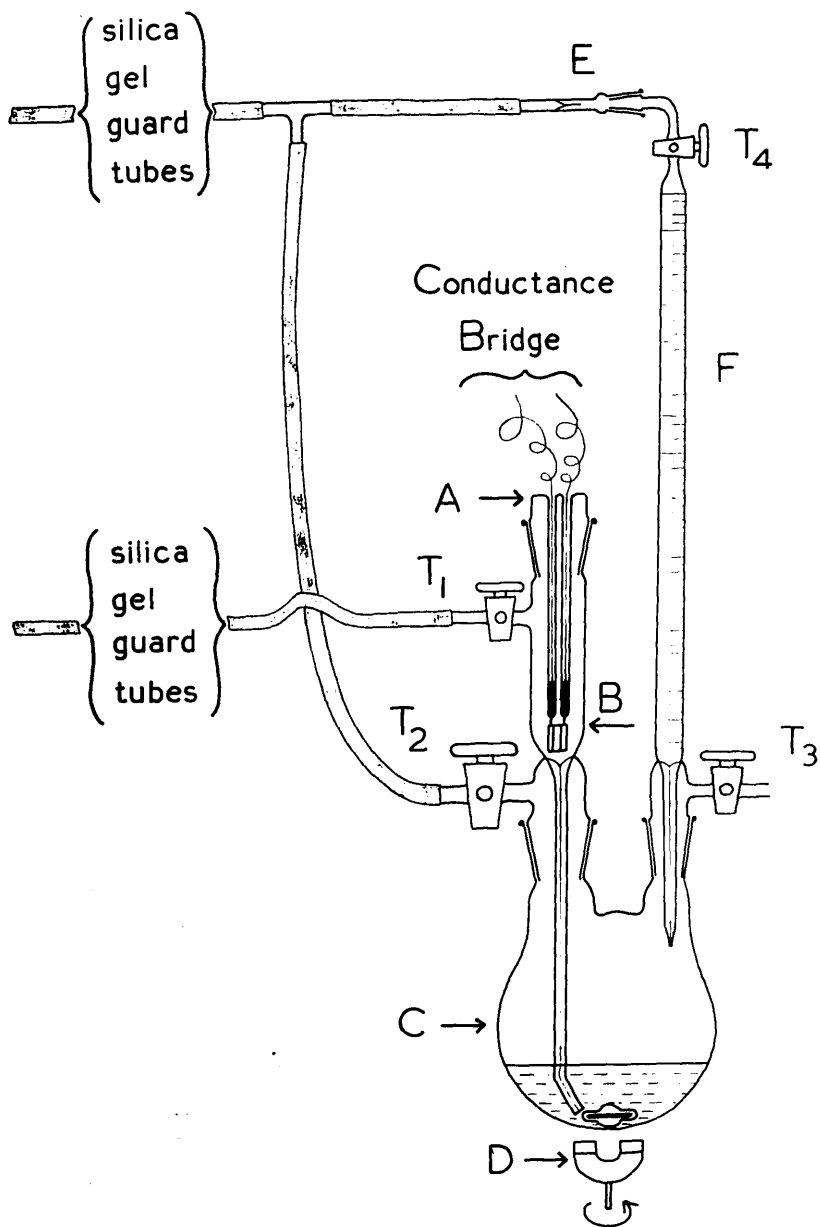

Fig. 25. Conductometric Titration Apparatus.

baked at 120 °C for 4 hours. The titrant of known concentration was prepared in a separate flask. To this the burette F (capacity 25 cc.) was attached and filled by gentle application of reduced pressure through tap T₄ (tap T₃ was opened to a system of drying tubes). Tap T₄ was then closed and the burette attached to the main system which was arranged as shown in the diagram.

Flask C (capacity 50 cc.) initially contained a known volume (ca. 25 cc.) of the solution of known concentration to be titrated. During titration tap T₃ was permanently closed and tap T₂ permanently open. Small additions of the titrant were made by opening tap T₄ (the flow of liquid from the burette was conveniently "damped" by the very fine constriction E). Complete mixing was ensured by the use of a magnetic stirrer D. To measure the conductance of the solution at each stage in the titration a sample was introduced through the capillary tube into the electrode chamber B by gently applying reduced pressure through tap T₁. The sample was held there by closing T₁. After noting the conductance the sample was returned to the titrat-

ing flask.

A standard pair of smooth platinum dipping electrodes, A, (area 1 cm^2 , cell constant 0.324 cm^{-1}) was used. The conductance was measured by the Mullard Conductance Bridge (E7566) when equilibrium had been attained after each addition of the titrant.

APPENDIX 4

APPARATUS FOR THE DETERMINATION OF TRANSPORT NUMBERS

The determination of transport numbers by the Hittorf method involves the measurement of small changes in the amount of electrolyte which take place in the solution in the vicinity of the electrodes when the solution is electrolysed. Although the method is straight forward in theory, there are several experimental difficulties to be overcome and this is reflected in the variety of forms of apparatus described in the literature for the determination of transport numbers by this method.

Since the concentration changes to be measured are usually small, it is important that mixing of the anode and cathode solutions is minimised. Mixing of the solutions within the apparatus may be brought about by diffusion, convection, or vibration. Attempts to reduce these errors by, for example, interposing a partition of sintered glass, or lengthening the column of the solution, only results in an in-

creased resistance of the system and consequently smaller concentration changes. Conversely attempts to increase the concentration changes by prolonged electrolysis or increased currents results in an enhancement of the above errors. The problem is one of constructing an apparatus with the optimum dimensions which will result in a maximum current with a minimum of diffusion.

Transport number determination in phosphorus halide systems is rendered more difficult because of the sensitivity of these compounds to moisture and tap-grease, and it was for the handling of these compounds that the following cell was designed.

The electrolysis cell was of the H-type with a middle (U-shaped) compartment as shown in Fig. 26. The inner diameter of the tubing was 14 mm. and at each electrode the width was enlarged. This is reported to reduce the resistance of the filled cell [79]. Instead of fitting glass taps for the purpose of emptying each compartment of the cell, fine, easily broken spindles were drawn out. This had the two-fold advantage of eliminating the use of tap grease

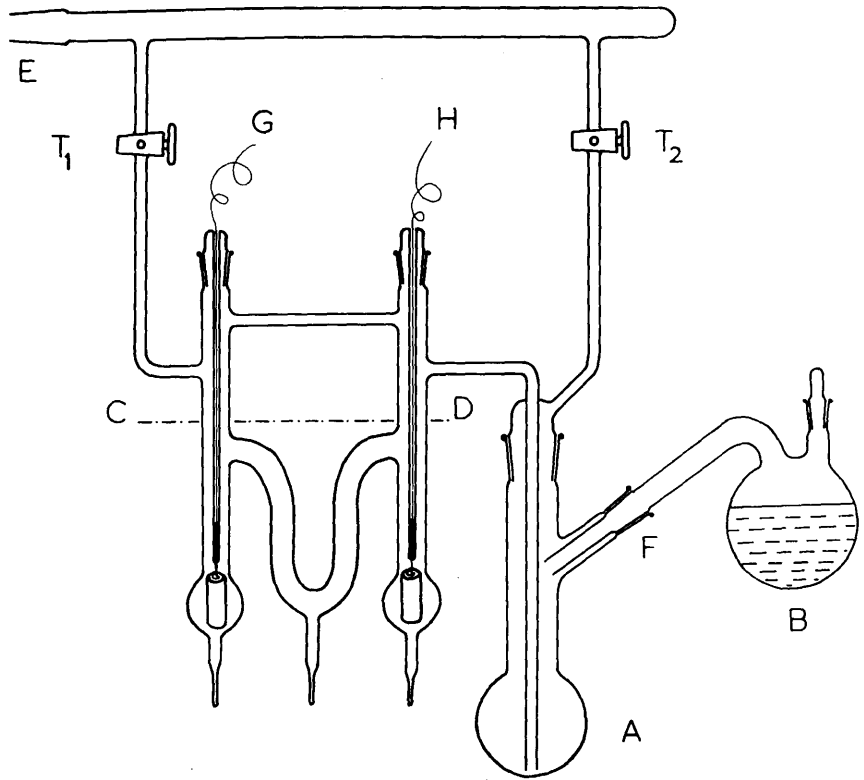

Fig. 26. Electrolysis Cell.

and enabling the cell to be immersed in a thermostat, thus dissipating the effect of local heating. The electrodes consisted of coiled smooth platinum foil and each had a total surface area of 37.5 cm^2 ; their distance apart was about 40 cm.

The remainder of the apparatus was designed in order that the solutions could be manipulated by pressure difference in a closed circuit. The following is a description of the experimental procedure adopted in using the cell.

The apparatus was attached at joint E to the vacuum system and before use it was flamed out in vacuo. Following this, dry air was allowed into the system. Flask B was then detached and the openings stoppered. The solution to be electrolysed was prepared in flask B, and when this was done B was rejoined to the apparatus. Taps T_1 and T_2 were closed at this stage and the main line evacuated. The solution was then transferred to flask A by rotating B about the through joint F. The cell was filled by suction to level C-D (by opening tap T_1) and dry air was then admitted to the system (via the main line) by careful adjustment

of taps T_1 and T_2 (after this the delivery tube contained no solution and the pressure above the solution was atmospheric). The H-cell was then immersed in a well stirred thermostat (at room temperature) and the solution electrolysed by the passage of direct current supplied by high tension batteries (up to 240 V).

After electrolysis the compartments were emptied (middle first) and the separate solutions analysed. The amount of current passed was determined from the increase in weight of the cathode of a silver coulometer* incorporated in the circuit. A sensitive milliammeter was also included in the circuit and during electrolysis the current was adjusted to about 10 mA.

* Design of Silver Coulometer. A sintered glass crucible (H4) was placed in a beaker (250 cc.) and the beaker filled with silver nitrate solution (10%) so that the crucible was about three-quarters filled with solution. The anode consisted of a cylinder of silver gauze interposed between the outer wall of the crucible and the inner wall of the beaker. The cathode was a platinum electrode (area 1 cm^2) immersed in the sol-

ution within the crucible. The crucible served to trap any silver which may have become disengaged from the cathode.

The cathode + crucible were weighed before the experiment. After the current had passed, cathode and crucible were washed with distilled water then acetone and finally dried in an air oven at 120°C. Reweighing enabled the weight of silver deposited to be calculated.

The apparatus was constructed as shown in the plan view, Fig. 2(a). Stirring was accomplished by the coil E of 2-6 mm. glass rod, at the end of a glass-enclosed soft iron core F. The core was rotated magnetically (an Belligné motor was used), rising and falling about 75 degrees. The thermometer pocket G was constructed of glass tubing with an inner diameter of

APPENDIX 5

CRYOSCOPIC CELL

A cryoscopic cell has been designed specially for the study of solutions of non-metallic halides. The apparatus, which was made of Pyrex glass, is shown diagrammatically in Fig. 27 (to avoid confusion two side-views are shown and in each of these one of the attachments is omitted).

The ground glass interchangeable joint A carries three attachments, namely, a thermometer pocket (B), a stirrer guide (C), and a bulb-breaker chute (D). These are arranged as compactly as possible as shown in the plan view, Fig. 27(a). Stirring was achieved by the coil E of 2.5 mm. glass rod, at the top of which was a glass-enclosed soft iron core F. The stirrer was operated magnetically (an Eclipse Power Magnet used manually), rising and falling about 75 times per minute. The thermometer pocket B was constructed of thin walled tubing with an inner diameter such that a 5° Beckmann thermometer fitted into it neatly. To ensure good thermal contact between thermometer and sol-

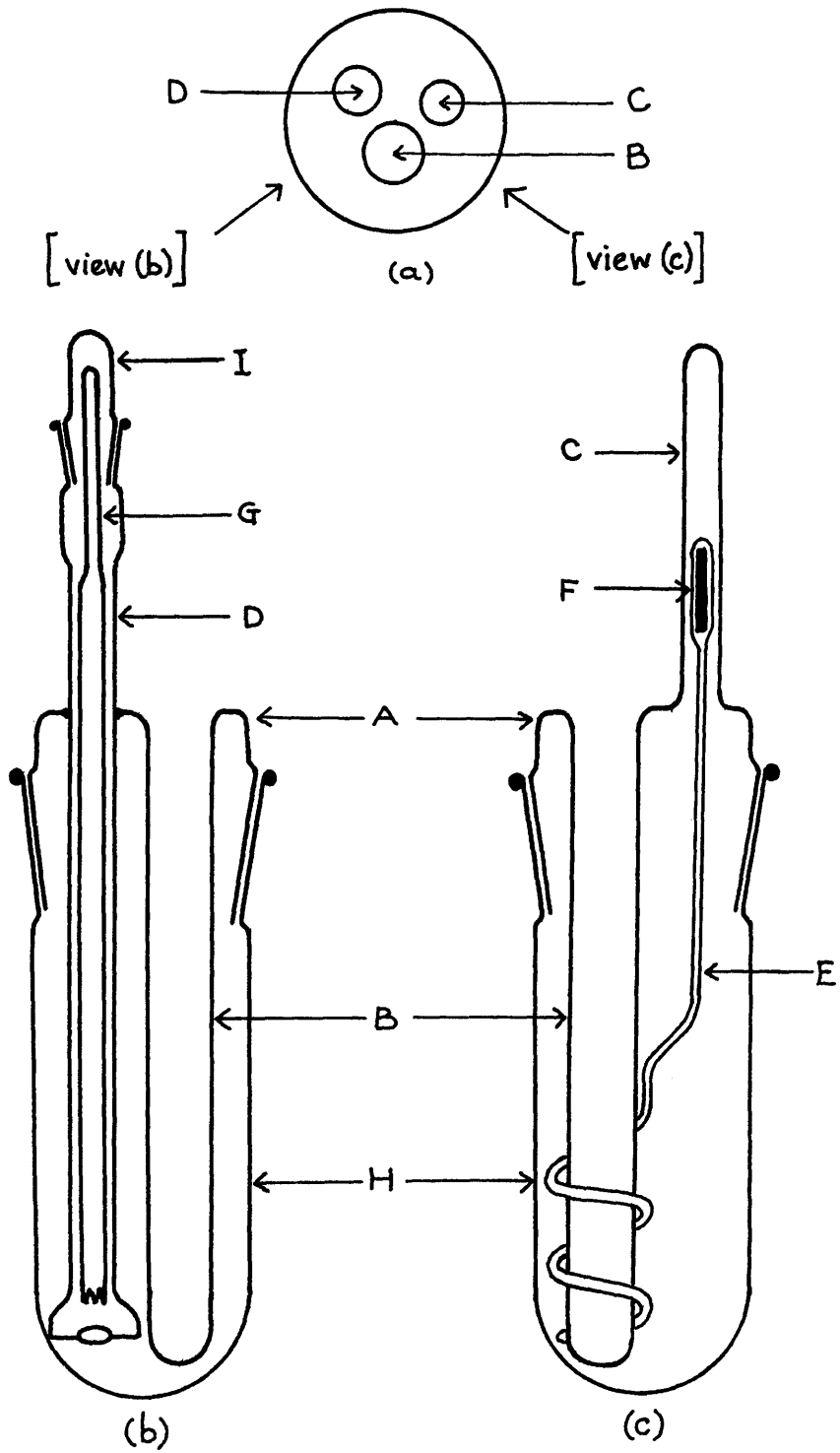

Fig. 27. Cryoscopic Cell.

ution, sufficient mercury was introduced into the pocket to cover the bulb of the thermometer when in place. The base of the thermometer pocket was situated about 1 cm. from the bottom of the cell.

The bulb-breaker chute consisted of 0.85 cm. inner diameter tubing which allowed a bulb of ca. 0.25 cc. capacity to be used. At the bottom of the tube was fixed a bulb-trap which prevented the bulb from leaving the chute, whilst holding it in position for breaking just below the surface of the solvent. The breaker D was a stout piece of glass rod which could move up and down freely within the chute. The end of this rod was jagged to facilitate fracturing of the bulb. It was usually necessary to allow the breaker to drop under gravity only about 2 - 3 cm. to effect the breakage.

The overall length of tube H, was about 19 cm., and the amount of solvent used was in the region of 80 cc. The tube H was placed in an air-jacket with a side-arm and this was in turn placed in the cooling bath. The purpose of the side-arm on the air-jacket

was to provide access to the surface of tube H. This was made use of when super-cooling proved troublesome, for in such circumstances a piece of solid carbon dioxide, fixed to a holder, was introduced through the side-arm and pressed firmly against the wall of the cell. This practice effectively induced crystallisation of the solvent.

Procedure. To prevent the slow ingress of moisture during freezing point determination the joints were greased with Florube W grease. The cell was weighed empty and then again when charged with solvent. The freezing point of the pure solvent was then determined (each freezing point was determined in duplicate or triplicate). Cap I was removed and the breaker extracted from the chute. A bulb containing a known weight of solute was dropped down the chute followed by the breaker which was allowed to fall on the bulb and shatter it. After replacing cap I, the freezing point of the solution was found. Further additions of the same or different solutes were made and the freezing point determined in the same way.

With this apparatus it is possible to measure freezing points of solutions to within ± 0.002 °C. The apparatus has been successfully used to measure freezing points down to about -25 °C.

1. Tuttle and ...
 2. Tuttle and ...
 3. ...
 4. ...
 5. ...

REFERENCES

1. ...
 2. ...
 3. ...
 4. ...
 5. ...
 6. ...
 7. ...
 8. ...
 9. ...
 10. ...

REFERENCES

1. Kastle and Beatty, Amer.Chem.J., 1899,21,392.
2. Kastle and Beatty, Ibid., 1900,23,505.
3. Oddo and Tealdi, Gazzetta, 1903,33,435.
4. Finkelstein, Z.anorg.Chem., 1923,105,10.
5. Walden, Z.phys.Chem., 1903,43,434.
6. Plotnikov, Ibid., 1904,48,230.
7. Finkelstein, Ibid., 1927,125,229.
8. Finkelstein, Ibid., 1925,115,306.
9. Prideaux, J.Chem.Soc., 1909,95,445.
10. Van Driel and Gerding, Rec.Trav.chim., 1941,60,869.
11. Ogier, Compt.rend., 1881,92,85.
12. Biltz and Jeep, Z.anorg.Chem., 1927,162,32.
13. Prideaux, Proc.Chem.Soc., 1908,214.
14. Chatterjee, J.Indian Chem.Soc., 1942,19,49.
15. Polesitskiĭ, Yashchenko, and Baranchik, Compt.
rend.Acad.Sci.U.R.R.S., 1942,34 No.3,83.
16. Koskoski and Fowler, J.Amer.Chem.Soc., 1942,64,850.
17. Popov and Schmorrr, J.Amer.Chem.Soc., 1952,74,4672.
18. Popov and Skelly, Ibid., 1954,76,3916.
19. Powell and Clark, Nature, 1940,145,971.
20. Van Driel and McGillavry, Rec.Trav.chim., 1943,
62,167.

21. Sidgwick, "The Chemical Elements and their Compounds", Oxford University Press, London, 1950, p.1194.
22. Popov and Skelly, J.Amer.Chem.Soc., 1954,76,5309.
23. Payne, J.Chem.Soc., 1953,1052.
24. Popov and Skelly, J.Amer.Chem.Soc., 1955,77,3722.
25. Hencke, Annalen, 1858,106,281.
26. Payne, unpublished results.
27. Aickin, Bayliss, and Rees, Proc.Roy.Soc., 1938, A169,234.
28. Gomberg and Schoepfle, J.Amer.Chem.Soc., 1919, 41,1655.
29. Larsen and Wittenburg, Ibid., 1955,77,5850.
30. Beckmann and Waentig, Z.anorg.Chem., 1910,67,17.
31. Gomberg and Sullivan, J.Amer.Chem.Soc., 1922, 44,1810.
32. Smith and Witten, Trans.Faraday Soc.,1951,47,1304.
33. Kraus and Taylor, J.Amer.Chem.Soc.,1947,69,1731.
34. "Inorganic Syntheses", McGraw-Hill, New York, 1939, Vol.2, p.151.
35. Parker and Parker, J.Amer.Chem.Soc.,1924,46,312.
36. Wurtz, Compt.rend.,1847,24,288.
37. Gladstone, Phil.Mag.,1849,35,353.

38. Wichelhaus, Ber.,1868,1,77.
39. Prinvault, Compt.rend.,1872,74,868.
40. Prinvault, Ber.,1872,5,323.
41. Michaelis, Ber.,1872,5,9.
42. Michaelis, Ber.,1872,5,411.
43. Geuther, Jenaische Z.f. Naturwissenschaft, X,128.
44. Stern, J.Chem.Soc.,1886,49,815.
45. Milobedski and Krakowiecki, Roczniki Chem., 1928,
8,563.
46. Milobedski, Chem.Listy,1932,26,458.
47. Milobedski and Krakowiecki, Roczniki Chem., 1930,
10,158.
48. Renc, Ibid., 1933,13,569.
49. Renc, Ibid., 1933,13,454.
50. Renc, Ibid., 1933,13,509.
51. Renc, Ibid., 1934,14,69.
52. Fialkov and Kuz'menko, Zhur.obshchei Khim.,1951,
21,433.
53. Fialkov and Kuz'menko, Ibid., 1952,22,1290.
54. Krakowiecki, Roczniki Chem., 1930,10,197.
55. Kraus and Vinge, J.Amer.Chem.Soc.,1934,56,511.
56. Popov and Swensen, Ibid., 1955,77,3724.
57. Kolthoff and Yutzy, Ind.Eng.Chem.Anal.,1937,9,75.

58. Noack, Annalen, 1883,218,85.
59. Anschütz and Emery, Ibid., 1889,253,105.
60. Autenrieth and Geyer, Ber., 1908,41,146.
61. Coe, Landauer, and Rydon, J.Chem.Soc.,1954,2281.
62. Anschütz and Emery, Annalen, 1887,239,301.
63. Anschütz, Boedeker, Broeker, and Wenger, Ibid.,
1927,454,71.
64. Professor H.N. Rydon, Private Communication, 1955.
65. Anschütz and Wenger, Annalen, 1930,482,25.
66. Anschütz, Koenig, Otto, and Walbrecht, Ibid.,
1936,525,297.
67. Kosolapoff, "Organophosphorus Compounds", Wiley,
New York, 1950. (a) p. 328.
(b) p. 186.
68. Waters and de Worms, J.Chem.Soc.,1949,926.
69. Gerrard, Green, and Phillips, Ibid.,1954,1148.
70. Forsman and Lipkin, J.Amer.Chem.Soc.,1953,75,3145.
71. Sidgwick, "The Chemical Elements and their Com-
pounds", Oxford University Press, London, 1950,
p. 1198.
72. Hinkel and Treharne, J.Chem.Soc., 1945,866.
73. Sidgwick, "The Chemical Elements and their Com-
pounds", etc., p. 1241.

74. Gutmann, Z.anorg.Chem., 1951,266,331.
75. Hein, Plust, and Pohlemann, Ibid., 1953,272,25.
76. Bartindale and Farrow, Private Communication per
Prof. H.N. Rydon.
77. Tucker, J.Soc.Chem.Ind., 1949,904.
78. Marie, Compt.rend., 1899,129,766.
79. Taylor, "A Treatise on Physical Chemistry",
D. Van Nostrand Co., New York, 1931.
p. 682.