

Push-out force and impulse measurement of seven types of small arms ammunition with three different surface states

Cite as: AIP Advances 9, 115016 (2019); <https://doi.org/10.1063/1.5128440>

Submitted: 19 September 2019 . Accepted: 30 October 2019 . Published Online: 18 November 2019

Michael Muster, Amer Hameed, David Wood, and Kilian Wasmer



View Online



Export Citation



CrossMark

ARTICLES YOU MAY BE INTERESTED IN

[Dynamic qualitative bolt force measurements for investigating influence factors on the pushout effect of small calibre ammunition](#)

AIP Advances 9, 065020 (2019); <https://doi.org/10.1063/1.5092167>

[Magnetic properties of bismuth substituted yttrium iron garnet film with perpendicular magnetic anisotropy](#)

AIP Advances 9, 115001 (2019); <https://doi.org/10.1063/1.5122998>

[Numerical study of an unsteady flow of thixotropic liquids past a cylinder](#)

AIP Advances 9, 115002 (2019); <https://doi.org/10.1063/1.5125731>

AVS Quantum Science

Co-Published by



RECEIVE THE LATEST UPDATES



Push-out force and impulse measurement of seven types of small arms ammunition with three different surface states

Cite as: AIP Advances 9, 115016 (2019); doi: 10.1063/1.5128440
Submitted: 19 September 2019 • Accepted: 30 October 2019 •
Published Online: 18 November 2019



Michael Muster,^{1,a)} Amer Hameed,^{1,b)} David Wood,^{1,c)} and Kilian Wasmer^{2,d)}

AFFILIATIONS

¹Centre for Defence Engineering, Cranfield University, Defence Academy of the United Kingdom, Shrivenham SN6 8LA, United Kingdom

²Laboratory for Advanced Materials Processing – Empa - Swiss Federal Laboratory for Materials Science and Technology, Feuerwerkerstrasse 39, CH 3602 Thun, Switzerland

^{a)} Author to whom correspondence should be addressed: michael.muster@cranfield.ac.uk

^{b)} a.hameed@cranfield.ac.uk

^{c)} d.wood@cranfield.ac.uk

^{d)} kilian.wasmer@empa.ch

ABSTRACT

This study analyzes the influence of lubrication treatments on the force absorbed by the breech bolt called push-out force. The results are of high interest for weapon-safety and durability studies, especially when it comes to weapon maintenance. A barrel-ammunition combination represents an expanding vessel under high pressure. The pressure rises from ambient up to 420 MPa in less than a millisecond. During such a highly dynamic process, purely static equations, describing the problem of the casing push-out force, may not be applied. Besides the dynamic behavior, the surface properties and geometry also play an important role. To investigate the push-out force, a measurement system based on a force washer was built. This system was validated using a crusher method and finite element analysis. The impulse was calculated using the data of the measured force to obtain additional information about the force-time properties of the push-out behavior. Untreated ammunition and two lubrication systems: “ice layer” and “oil lubricated,” as well as seven different ammunition sizes ranging from 5.56 to 12.7 mm were considered. The response was the force absorbed by the bolt while the cartridge provides rear obturation to the combustion gases. It was found that both the casing geometry and its treatments have a significant influence on the push-out force.

© 2019 Author(s). All article content, except where otherwise noted, is licensed under a Creative Commons Attribution (CC BY) license (<http://creativecommons.org/licenses/by/4.0/>). <https://doi.org/10.1063/1.5128440>

INTRODUCTION

The aim of this contribution is to measure the influence of differently treated cartridge surfaces on the breech-bolt force in a range of small-arms ammunition. Treatment types analyzed were untreated, *ice layer*, and *oil lubricated*. Ammunition types investigated were 50 Browning, 375 SWISS P, 338 Lapua Mag., 7.5 × 55 Suisse, 308 Win., 223 Rem., and 9 mm Luger.

Due to safety and functionality reasons, the chamber of the weapon needs to be sealed by the casing during the process of firing. This sealing process also decreases the breech-bolt force. During the acceleration phase of the projectile, the casing experiences a highly

dynamic environment. Under such circumstances, the cartridge casing can be considered as a pressure vessel, which undergoes a plastic deformation while the propellant burns in the chamber. The plastic deformation of the cartridge, which prevents the rearward escape of firing gases between the weapon chamber and cartridge, is called obturation and is closely related to the push-out force. For safety reasons, the obturation of the casing needs to produce a seal. Otherwise, unpredictable gap flows may occur, known as the dangerous burn-through or gas-wash phenomenon.

A thermodynamic gap flow investigation was made by Squire and Donnard.¹ They described the efflux of luminous gases at the weapon breech, which is highly abrasive and can lead to serious

damage of the weapon. At worst, it can harm the rifle person. Squire and Donnard described the problem in detail, referring to classical melting theory. They investigated this experimentally by drilling a small hole in the head of the casing. They observed that even a minor scratch might result in a burn-through. This investigation was made with aluminum casings, which have a significantly lower melting point as compared to regular brass casings. However, the possible risks reveal the importance of a controlled obturation process guaranteeing the sealing of the pressure vessel system. Hence, in recent years, several patent applications, describing possible technical approaches to solve the sealing problem of the ammunition barrel system for small-caliber ammunition^{2,3} but also large-caliber applications,^{4,5} have been filed. The obturation of the casing not only affects the sealing process but also has an influence on the force taken/supported by the breech bolt. In the case when the push-out force exceeds a certain level, the breech bolt can break, which leads to severe damage or even can harm the operator.

Due to the internal pressure and the obturation process, the casing is pushed against the wall of the chamber. In other words, it means that the overall push-out force is not entirely taken by the breech bolt. The friction between the chamber wall and casing bears some of the overall push-out force. The friction between the interface boundaries is an important factor for bolt force assessments, which is described in the literature, in particular for steel and brass systems. According to Aida,⁶ the static and dry Coefficient of Friction (COF) of brass and steel is in the order of 0.19.⁶ In the case of the *oil lubricated* and kinetic brass-steel combination, the COF is around 0.09, which is consistent with recent publications.⁷ In terms of lubrication, it is found that thin water layers may also act as a performant lubricant.⁸ However, lubrication is only one of the six main factors the bolt force depends on; the other five factors are as follows:

- (1) The surface area of the case head where the pressure acts,
- (2) The pressure in the casing,
- (3) The friction between the chamber wall and the case body,
- (4) The material properties of the chamber and casing,
- (5) The chamber geometry, i.e., fluted or smooth.

By controlling these five factors and measuring the push-out force, it is possible to get information about the effect of the lubricant on the obturation process during firing. Processes such as obturation are difficult to measure and are nowadays simulated using Finite Element Analysis (FEA).^{9,10} The advantage of FEA is that numerous parameters can be investigated within one single model by sensitivity studies. With only minor changes in the model, one can analyze geometric parameters.

Besides numerical approaches, it is also possible to investigate the push-out force analytically at the breech, as suggested by Allsop *et al.*¹¹ The extraction-force equation can be used to estimate the push-out force. Such an approach is unsuitable for solving the dynamical problem of the obturation and cartridge sealing since only part of the analytical model can be applied. The main reason is that in the equation of Allsop *et al.*, the friction is assumed to have a constant value. Specific properties of the propellant, such as pressure oscillations, described by Elkarous *et al.*,¹² are neglected.

Several types of small-caliber ammunition are available for both military and law enforcement purposes. The most often-used cartridge type is the 9 mm Luger. This type of ammunition is highly

standardized and utilized in pistols all over the world.¹³ The most powerful caliber belonging to the family of small-caliber ammunition, exploited by many armies, is the 12.7 × 99 mm, also known as 50 Browning or 50 BMG. This caliber is mostly for the heavy machine gun Browning M2, which has its origins in 1918.¹⁴ The 50 BMG is especially interesting in this investigation since this ammunition type caused problems concerning the reloading cycle and bolt/push-out force and was therefore deeply investigated using FEA methods.¹⁵ Besides FEA investigations, it is also possible to measure forces at the case head using force washers. Ritter *et al.*¹⁶ measured the force on the igniter and pressure inside the cartridge with a piezoelectric force sensor. This provided confidence in predicting the behavior occurring in the barrel chamber. They mentioned that the impulse has a significant influence on the system.

Sensors relying on the piezoelectric effect are often selected for standardized pressure measurements^{17–19} and so are very suitable for ballistic investigations. However, ballistic pressure investigations rank among the most challenging types of measurement to be conducted.

Decades ago, due to the lack of suitable electronic measuring equipment, these measurements were conducted using a simple copper crusher method. The copper crusher method consists of a copper cylinder which is deformed depending on the pressure produced in the chamber of the weapon during the firing process.^{20,21} Even today, the copper has its legitimation for cross-reference purposes. Elkarous *et al.*²² investigated the sensing behavior of two piezoelectric pressure sensors and compared the results with a copper crusher. They investigated the amount of deformation of the copper cylinders after the shooting tests, using FEA to obtain quantitative results about the pressure applied. An approach to apply the crusher method directly on the casing is to turn notches into the head of the casing. Similar to copper, the brass of the casing is also a highly defined material and can be investigated as the crusher method.

However, ballistic pressure measurements in the chamber of a weapon are regularly conducted and important for security assessments. In contrast, breech-bolt force measurements are rarely made even though the breech bolt is a very important part of the weapon. The force on the breech bolt has a significant influence on the firing process, weapon functionality, and safety. This paper confirms that the breech-bolt force depends significantly on the surface treatment, which is one of the relevant issues. Consequently, this study is a supplement to and enrichment of existing studies on diagnosis associated with the firing process for small-arms ammunition.

EXPERIMENTAL PROCEDURES

To investigate the influence of the ammunition on the push-out force, seven types of casings and three surface states were selected. The types of casings are 50 Browning, 375 SWISS P, 338 Lapua Mag., 7.5 × 55 Suisse, 308 Win., 223 Rem., and 9 mm Luger which are presented in Fig. 1(a). The push-out force relevant properties of the ammunition type are given in Table I. This table contains properties having a direct influence on the push-out force such as the muzzle energy, casing surface, and the diameter of the mouth of the casing. The bullet weight and the projectile type influence the

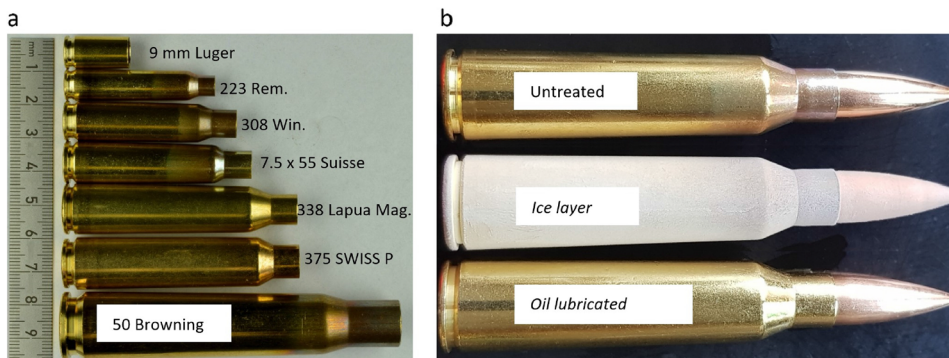

FIG. 1. (a) Picture of casings tested and (b) picture of the different surface states.

TABLE I. Specifications of the investigated ammunition types.

| Name | Muzzle diameter (mm) | Bullet weight (g) | V_0 (m/s) | Muzzle energy (joule) | Projectile type | Casing surface (mm ²) |
|-----------------|----------------------|-------------------|-------------|-----------------------|-----------------|-----------------------------------|
| 50 Browning | 12.70 | 48.5 | 825 | 16 505 | Solid | 5219 |
| 375 SWISS P | 9.50 | 22.7 | 850 | 8200 | FMJ | 3005 |
| 338 Lapua Mag. | 8.60 | 16.3 | 860 | 6028 | FMJ | 2802 |
| 7.5 × 55 Suisse | 7.50 | 11.3 | 780 | 3437 | FMJ | 1878 |
| 308 Win. | 7.62 | 11.4 | 770 | 3380 | FMJ | 1654 |
| 223 Rem. | 5.56 | 3.6 | 980 | 1729 | FMJ | 1152 |
| 9 mm Luger | 9.00 | 8.0 | 365 | 533 | FMJ | 497 |

push-through force of the projectile in the barrel during acceleration, which also affects the push-out force. In general, Full Metal Jacket (FMJ) projectiles need a lower push-through force as compared to monolithic (solid) projectiles.²³ All types of ammunition were certified according to the most recent Commission Internationale Permanente (CIP) regulations.¹⁷ The 9 mm Luger is the only casing without bottleneck design investigated. By comparing the bottleneck-type casings, the differences are in the angle and diameter-length ratio. For the ammunition, three surface states were selected: untreated, *oil lubricated*, and *ice layer*, which are seen in Fig. 1(b). The surface lubrications *oil lubricated* and *ice layer* are highly defined and may occur in real-world usage. The *oil lubricated* case simulates the case where the ammunition might have some lubricant at the boundaries of the inner chamber of the weapon. This is the case when the weapon is cleaned and oiled before use. To oil lubricate the casings, a fluid referred to as Klübersynth MZ 4-17 was applied. This lubricant is recommended for the maintenance of small arms such as hunting and sporting rifles.²⁴ The casing surface was treated with 0.4 mg/cm² lubrication oil.

In contrast, the *ice layer* state reproduces the situation where the ammunition is significantly colder than the weapon so that it is possible that the ammunition condensates quickly. In this study, to investigate the *ice layer* treatments, the ammunition was cooled to -30°C for 1 h and then exposed 2 min to ambient temperature. This approach permitted to build a highly defined thin *ice layer* with a mass of 0.5 mg/cm², as shown in Fig. 1(b). The condensation process was controlled with an analytical balance (Mettler, Switzerland) and a stopwatch. The resulting water film is very thin and does not

increase the gap between the chamber and the casing. Furthermore, it is melted immediately after putting it into the barrel.

The ammunition was first tested using an Electronic Pressure Velocity and Action Time (EPVAT) (HPI, Austria) measurement setup,²⁵ recognized by NATO and CIP testings. The amount of propellant is known from production certificates, and the casing surface can be calculated from the specific dimensions published in the CIP documents.¹⁷

Piezoelectric measurements

The piezoelectric force measurement was conducted ten times for each ammunition type so that the reproducibility and associated errors are statistically relevant. The push-out force measurement device is similar to the EPVAT system, as shown in Fig. 2. It includes an interchangeable proof barrel, rigid housing that is made of cast iron to reduce the effect of vibrations during shooting. In addition, it has a trigger device attached to the force measurement plate, which is shown in Fig. 3. The trigger device and the force measurement plate, which also serve as a breech bolt, need to be disassembled after every shot is performed. The key difference to a regular EPVAT system was that the breech bolt was equipped with a force washer Kistler 9041a (Kistler, Switzerland), shown in Fig. 3. This sensor has an eigen frequency of 65 kHz and is capable of measuring short time events. A National Instruments USB-6366 (NI, USA) data acquisition device was used for all tests. Accurate time and the amplitude raw signal were necessary for the impulse measurements. Hence, the data acquisition rate was 2 MHz (0.5 μs step size) with a 16-bit

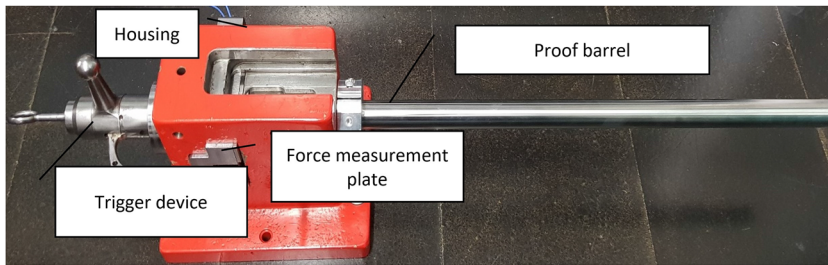

FIG. 2. Measurement setup with a measurement plate.

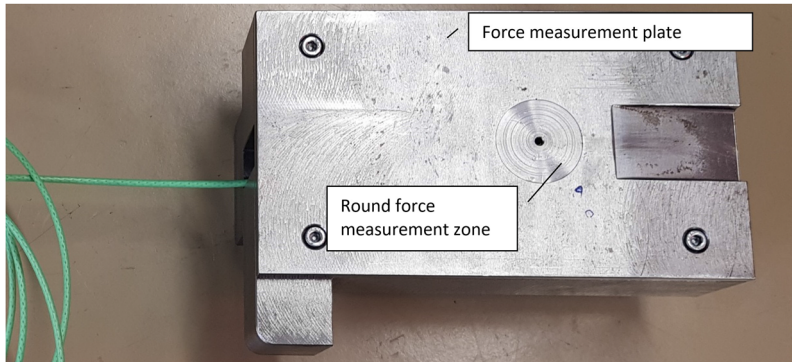

FIG. 3. Force measurement plate.

resolution. The impulse was calculated using the time integral of the force signal. The filtering of the acquired raw data was identical in all cases. The filtering was a combination of 20 kHz Butterworth low-pass filter which is known from NATO standards concerning small-caliber ammunition¹⁹ and an RMS signal envelope²⁶ with a step size of 170 samples. The filtering approach and the overall measurement system with a force washer are the same as the one described in the work of Muster *et al.*²⁷ The effect of this filtering as compared to the raw signal can be seen in Fig. 4. The signal is not loaded with high-frequency parts over 20 kHz. However, the time property of the first rise remains persistent.

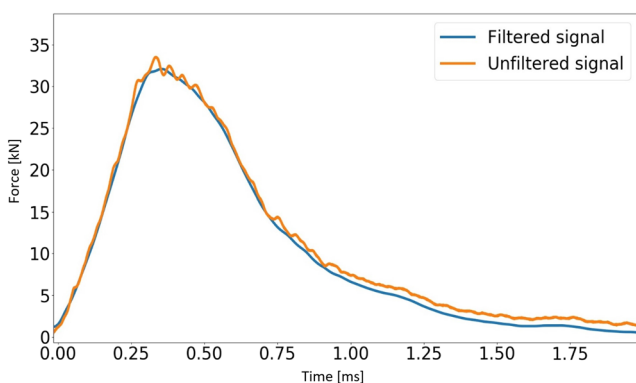

FIG. 4. Typical force vs time curve of oil lubricated 308 Win. ammunition. Filtered and not filtered. For the filtering process, a bandpass, RMS signal envelope approach was applied.

Case head crusher assessment

The 338 Lapua Mag. was chosen to conduct the cross-verification of the piezoelectric measurements for two reasons. First, it is a caliber mainly used in sniper rifles. Second, it has a rigid breech bolt. Bolt-action rifles are with rigid bearings of main interest for push-out force and safety investigations. In addition, the 338 Lapua Mag. was assessed since it provides enough material at the casing head to contain notches, which is necessary for later crusher investigations. These notches have resulted in defined spikes, which deform under the high forces occurring during the firing process. This deformation was measured using an analog microscope with a measurement X-Y table (Wild Heerbrugg, Germany).

The unloaded notch pattern of the case head (see Fig. 5) was replicated using a CAD package of a FEA software. The FEA software applied for this investigation was FORGE[®] Version 4.6.2.1 (Transvalor, USA), optimized for metal forming processes.²⁸ The casing hardness was assumed to be homogeneous with the constant hardness value of 180 Hardness Vickers (HV₃₀). This drawn casing head was placed between two bearings, which were assumed to be fully rigid. A quarter symmetry model was constructed, to save computation time. The load was built up stepwise on a gradient, to obtain a force-step curve. No oscillations were assumed. The element and mesh size were set to “automatic.” The force was applied “static,” and the mesh for the analysis was generated automatically and dynamically. Each surface state type was assessed three times. With this approach, we were able to replicate the deformation under an applied force to obtain a semi-quantitative result. The reason for this verification system is the same as presented by Elkarous *et al.*,²² which is to obtain a result from a different measurement approach.

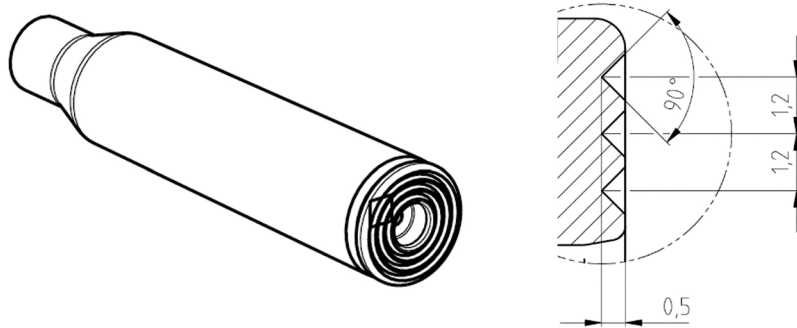

FIG. 5. Modified "crusher" casing head using notches which are turned in the casing head.

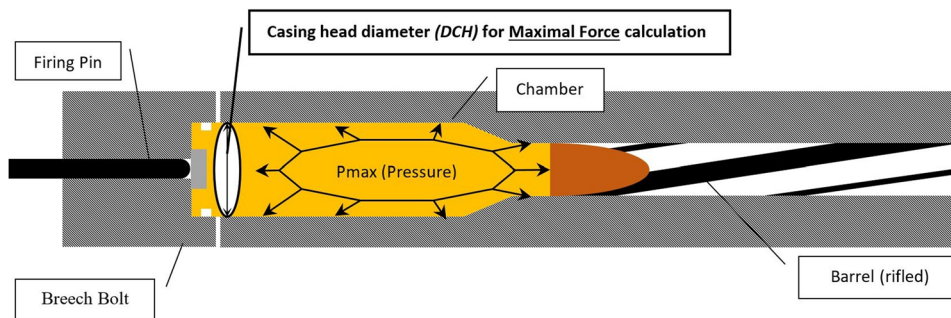

FIG. 6. Schematic view of the barrel cross section. The maximum possible is calculated according to $F_{max} = P_{peak} \cdot DCH$.

Analytic calculations

Besides the crusher gauge and FEA, the calculated maximum force (F_{max}) is another straightforward method that can be used for an analytic calculation of the push-out forces of the ammunition types investigated. This method assumes that the maximum possible force is delivered on the breech bolt. The calculation of the theoretical F_{max} can be simplified since it depends only on two factors: the peak pressure (P_{peak}), a measured value, and the casing head diameter (DCH) (see Fig. 6) which is taken from the CIP regulations. Then, $F_{max} = P_{peak} \cdot DCH$ and the results are given in Table III. This maximal force scenario applies only if no obturation and no friction exist between the boundaries of the casing and the chamber. Under such circumstances, it is obvious that the theoretical F_{max} cannot be exceeded in real-world measurements and so must be taken as a maximum reference.

More complex equations for push-out measurements rely on several parameters such as the friction coefficient, materials, geometrical properties, and the peak pressure.¹¹ These parameters are hard to measure during the experiment and so must be simplified. Another drawback of this approach is that the dynamic properties of the projectile acceleration process are neglected.

RESULTS AND DISCUSSION

This section is divided into two sections: the piezoelectric measurements and the case head crusher assessment. The piezoelectric measurements are divided into four parts. Single force curves according to the different ammunition types are presented. They

give an impression about the force-time behavior. Then, a table summarizes the results, in particular an important factor between the measurement and the worst-case scenario. Third, boxplots summarized the statistics of the acquired results. Finally, the measurements are then cross verified using a crusher method with FEA.

Piezoelectric measurements

Figures 7–9 show typical push-out force vs time curves acquired with the force measurement instrument for the seven casing types. As expected, just after firing, the forces increase drastically before decreasing gradually. Most of the sharp rise takes place within 1 ms, whereas the force decreases take place between 0.8 and 3 ms

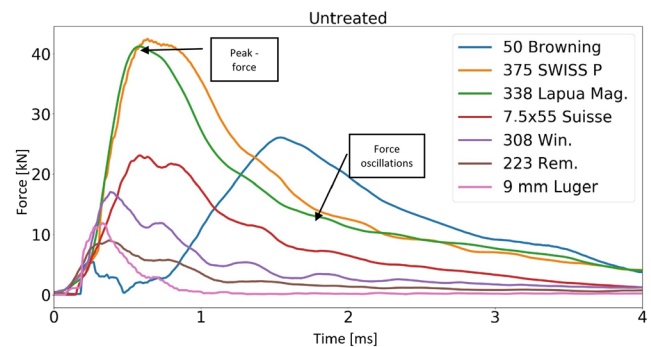

FIG. 7. Typical force signals acquired from the untreated ammunition.

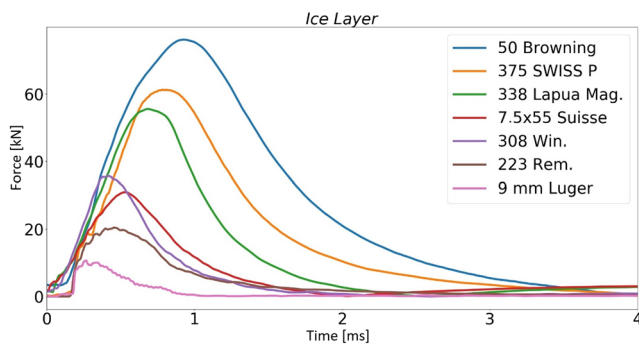

FIG. 8. Typical force signals acquired from the ice-layer-treated ammunition.

depending on the casing. The 9 mm Luger is the only casing without a bottleneck and has a unique push-out curve as compared to the other curves. After a short rising time, the maximum force (F_{peak}) measured is lower than the other casing type followed by a decrease to zero force within only 1 ms, and evidence of this is given in Figs. 7–9. The reason is that the 9 mm Luger proof barrel (100 mm) is much shorter as compared to the other barrels. In contrast, the 50 Browning has a much longer barrel (1200 mm), and this leads to longer acceleration time. The difference in acceleration time is independent of the surface state.

Figures 7–9 are closely related to Table II, which summarizes the measured but also the calculated forces for the three surface states. $\overline{P_{peak}}$ was acquired according to the CIP regulations. It represents the average value from the pressure maxima of ten single shots. For each ammunition and surface state, $\overline{F_{peak}}$ was averaged over a set of ten shots and F_{max} was the maximum push-out force value in the system. This table also contains an important value which is defined as $\overline{F_{peak}}/F_{max}$. This value shows the measured force in relation to the absolute maximal possible force (F_{max}). Also, one main relation between the figures and the table is the average force ($\overline{F_{peak}}$), which is an average value of peak values of the force curve shown in Fig. 7. This is a very artificial value since there is always some obturation and friction in the system which lower the push-out force.

In Table II, no significant difference is observed in the average maximum pressure ($\overline{P_{peak}}$) and F_{max} for the untreated and oil

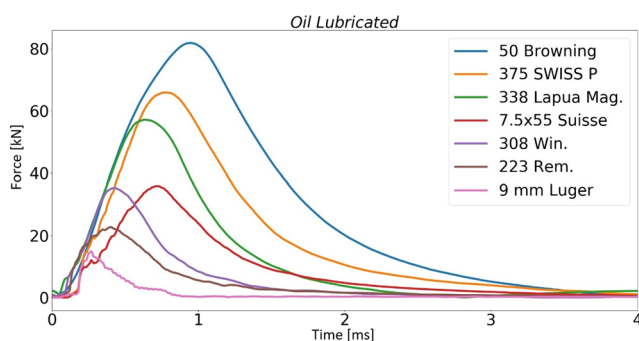

FIG. 9. Typical force signals acquired from oil lubricated ammunition.

lubricated ammunition. In contrast, a slight difference (but significant) is visible in $\overline{P_{peak}}$ between the untreated and ice layer ammunition. This is due to the burning properties of the propellant and igniter that are affected during cold conditions.

The results of the untreated surface state are shown in Fig. 7 and Table II. In Fig. 7, force oscillations, which are caused by the stick-slip effect, can be observed and were detected in all untreated surface states. Some oscillations are high in amplitude and reach up to 1/10 of the maximum push-out force; this affects the reproducibility of the measurements. For the untreated surface state, it is possible to identify three different casing groups. The first group is made by the 9 mm Luger only, which shows a sharp peak and reaches up to 72% of F_{max} ; see Table II. The second group is made of 375 SWISS P, 338 Lapua Mag., 308 Win., and 7.5 × 55 Suisse. These casings showed a similar relation for $\overline{F_{peak}}/F_{max}$ values ranging from 42% to 61%. The third group is very interesting as it comprises the largest and smallest projectile diameter investigated (223 Rem. and 50 Browning, see Table I). These two ammunition types showed only 25%–26% of the maximum possible push-out force (see Table II), which is a strong indication of a good obturation process. The reason for this behavior might be the similar geometrical constraints of the casings; see the geometry of these two casing types [Fig. 1(a)]. For the untreated surface state, it is also interesting to note that although the 50 Browning has twice of the muzzle energy of the 375 SWISS P (see Table I), the 50 Browning has lower push-out force as compared to the 375 SWISS P. Actually, the peak-force of the 50 Browning is reached more than 1.5 ms after the first signal rises. All other casing types reached the peak-force between 0.3 and 0.5 ms after. One reason is that the propellant used for this largest investigated caliber is less vigilant; this leads to delayed peak pressure. Another possible reason for the delayed peak-force is the stick-slip phenomenon of the ammunition, an effect that can be observed between 0.2 and 0.7 ms in the case of the 50 Browning. In contrast, the 375 SWISS P produces the most significant force at the bottom of the casing (up to 49 kN) (see Fig. 7), a behavior true for all force curves investigated in this work. This caliber reaches on average 53% of the maximum push-out force (see Table II).

The surface state *ice layer* influences not only the coefficient of friction of the casing but also the burning properties of the propellant. However, no significant difference concerning the pressure and velocity of the projectile was observed.

The *ice layer* surface state rises the push-out force significantly for every ammunition type and affects the obturation process. All ammunition types show between 73% and 97% of the maximal force, which is remarkably high when considering the safety of the system. The *ice layer* state revealed a significant influence on the force oscillations of all bottlenecked casings. All force signals are steadily rising and falling. Compared to the untreated surface state, fewer oscillations occur. The force signal from this surface state is comparable with the signal from the regular pressure measurements. The peak-force is correlated with the muzzle energy, which is an indication that the thin water layer affects the obturation process significantly. This is consistent with the statement of Paliy *et al.*,⁸ who reported that, under certain circumstances, water acts as a high-performance lubricant.

For the *oil lubricated case*, a thin film of Klübersynth MZ 4-17 was applied. The resulting push-out forces are comparable with those from the *ice layer*. However, for example, the 338 Lapua Mag.

TABLE II. Tabular representation of the measured properties. The " $\overline{F_{peak}}/F_{max}$ " represents a very important value. A high value indicates that almost no obturation takes place and may affect weapon safety.

| Cartridge | Surface state | $\overline{P_{peak}}$ (MPa) | F_{max} (kN) | $\overline{F_{peak}}$ (kN) | $\overline{F_{peak}}/F_{max}$ (%) |
|-----------------|-----------------------|-----------------------------|----------------|----------------------------|-----------------------------------|
| 50 Browning | Untreated | 310 | 102.0 | 2500 | 25 |
| | <i>Ice layer</i> | 305 | 100.0 | 8538 | 85 |
| | <i>Oil lubricated</i> | 310 | 102.0 | 8538 | 84 |
| 375 SWISS P | Untreated | 390 | 76.0 | 4010 | 53 |
| | <i>Ice layer</i> | 385 | 75.0 | 6480 | 86 |
| | <i>Oil lubricated</i> | 390 | 76.0 | 6480 | 85 |
| 338 Lapua Mag. | Untreated | 380 | 66.0 | 4040 | 61 |
| | <i>Ice layer</i> | 382 | 66.0 | 5640 | 85 |
| | <i>Oil lubricated</i> | 380 | 66.0 | 5640 | 85 |
| 7.5 × 55 Suisse | Untreated | 320 | 40.0 | 2110 | 53 |
| | <i>Ice layer</i> | 310 | 39.0 | 3475 | 89 |
| | <i>Oil lubricated</i> | 320 | 40.0 | 3475 | 87 |
| 308 Win. | Untreated | 330 | 37.0 | 1570 | 42 |
| | <i>Ice layer</i> | 315 | 36.0 | 3500 | 97 |
| | <i>Oil lubricated</i> | 330 | 37.0 | 3570 | 96 |
| 223 Rem. | Untreated | 400 | 29.0 | 750 | 26 |
| | <i>Ice layer</i> | 390 | 28.0 | 2160 | 77 |
| | <i>Oil lubricated</i> | 400 | 29.0 | 2160 | 74 |
| 9 mm Luger | Untreated | 200 | 17.0 | 1230 | 72 |
| | <i>Ice layer</i> | 205 | 17.5 | 1280 | 73 |
| | <i>Oil lubricated</i> | 200 | 17.0 | 1280 | 75 |

casings are subjected to fewer stick-slip effects (compare the green lines in Figs. 8 and 9).

To compare the statistical results of the experiments, one decided to separate the ammunition into two groups: smaller and larger ammunition types based on their muzzle energy delivered. The smaller ammunition types were defined for ammunition delivering muzzle energy of less than 3500 J, and the statistical results are given in Figs. 10(a) and 11(a). The smaller ammunition types are normally used in self-loading firearms. In contrast, the larger ammunition types are delivering muzzle energy higher than 6000 J, and their statistical results are shown in Figs. 10(b) and 11(b). These calibers are used by snipers and are often used in weapons with bolt-action. Bolt-action rifles with a rigid bearing are strongly affected by insufficient obturation processes and large push-out forces. A comparison of the different smaller and larger ammunition types is presented in the boxplots in Fig. 10 containing the information about all force measurements performed in this study. They represent median, quartiles, as well as extreme values.

We can see that the force delivered on the breech bolt increases in the treated surface states with increasing muzzle energy (compare Fig. 10 with Table I). For all bottleneck casings, it is seen that the untreated surface state has a relatively low push-out force, whereas the push-out forces for the treated surface states are significantly

higher. The *ice layer* causes a less significant rise in the push-out force than the *oil lubricated*.

It is worth comparing the 7.5 × 55 Suisse with the 308 Win. casings as both have almost the same muzzle energy values, and they are the only caliber investigated with interchangeable projectiles. However, the casing geometry differs slightly, which leads to different push-out force patterns. By comparing both casings, we can conclude that the overall geometry influences the push-out force. This observation of a geometrical dependency is supported by the different sized calibers 50 Browning and 223 Rem.; see Fig. 1(a). They react with a similar force pattern on the surface state. The absolute force value and its spread are low in the case of the untreated surface, and both rise significantly after changing the surface state with lubricant. Some of the measured 9 mm Luger peak-forces are so high that they reach almost the calculated maximum possible force. In this case, the sealing of the casing in the chamber might break and thereby release some of the hot and highly compressed gas into the weapon. The scatter in the results of the nonbottlenecked 9 mm Luger is the largest as compared to all other types of ammunition investigated. For the bottleneck casings investigated, the 338 Lapua Mag. shows a large scatter.

Figure 11 presents the results of the impulse transmitted to the breech bolt. The impulse gives information about the duration of the force applied on the breech bolt. This factor is important because

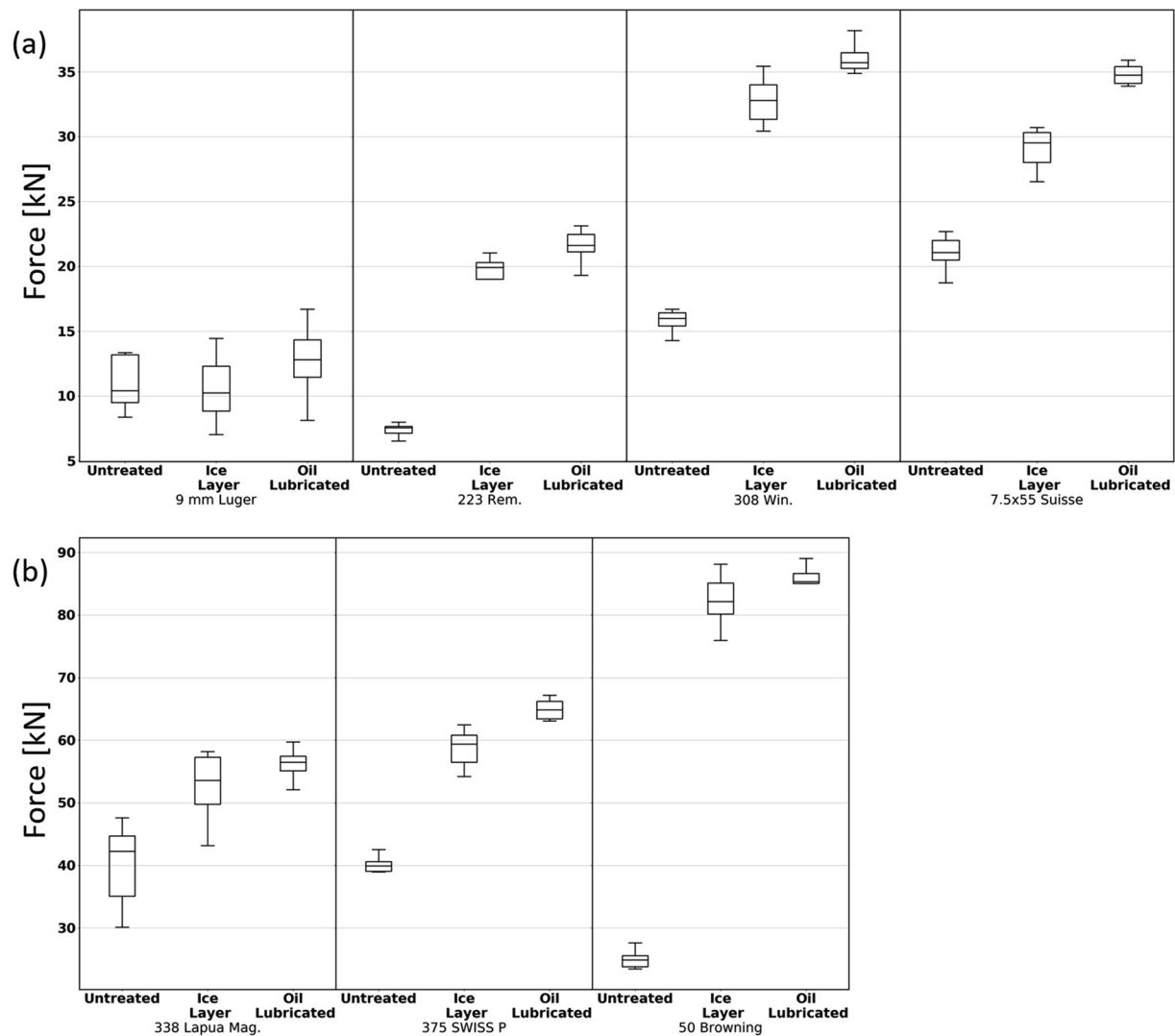

FIG. 10. Force boxplots of the investigated caliber range: (a) represents the smaller cartridge types and (b) represents the larger cartridge types.

some breech bolt systems are more sensitive when a load is applied for a certain time. The impulse transmitted at the base is represented by the integral of the force-time curve, and it also depends on the length of the barrel. Based on Fig. 11, no evident difference in the impulses was observed between the treated and untreated 9 mm Luger ammunition. The average impulses transmitted to the breech bolt vary between 7 and 59 N s in the untreated surface states. This range is larger for the lubricated surfaces, which varies between 6 and 120 N s. The lack of stick-slip effect in the treated surfaces prevents the chamber from taking big amounts of impulse leading to an enlargement of the range between the min and max value. In contrast, all treated bottleneck casing types show a decrease in impulse variation. The theory that the barrel chamber cannot take significant amounts of impulse if the casings are treated is supported by this decrease in impulse variation.

Case head crusher assessment

The case head crusher assessment for the 338 Lapua Mag. was used to cross verify the electronic measurements. In such highly dynamic environments, there is a distinct possibility that parts or tolerances of the measurement system influence the quality of measurements themselves. The verification was conducted in a two-stage approach, via optical investigation and FEA. Figure 12 presents pictures of the case heads before firing [Fig. 12(a)] and after for the three surface states. This optical investigation showed already obvious differences concerning the casing-head deformation. For example, the less flattened ring contour in Fig. 12(d) is due to the different hardness of the casing and is prominent in the outer ring.

Furthermore, the outer ring is less supported due to the extraction groove. In a second step, the FEA was performed and its results

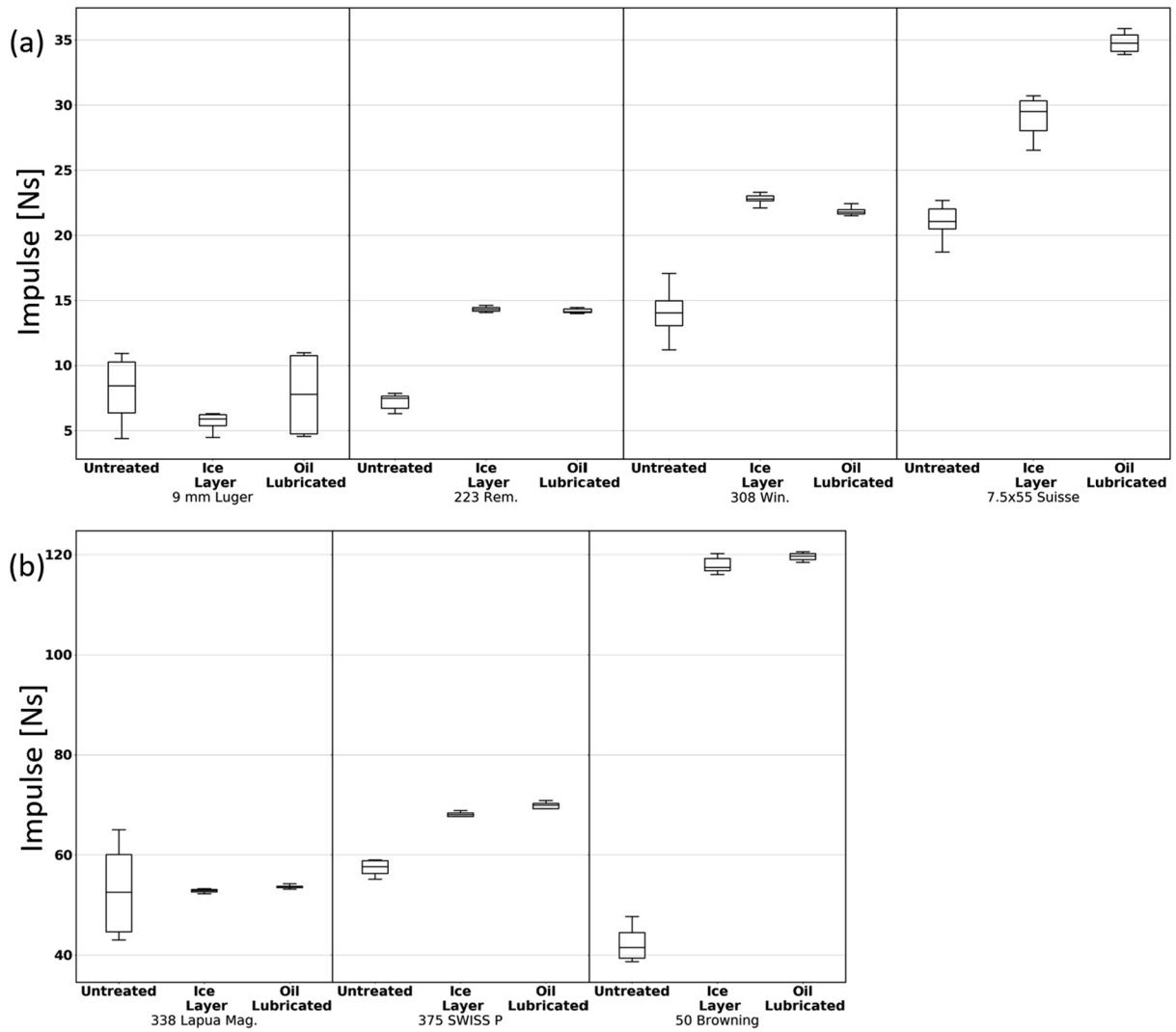

FIG. 11. Impulse boxplots of the investigated caliber range: (a) represents the smaller cartridge types and (b) represents the larger cartridge types.

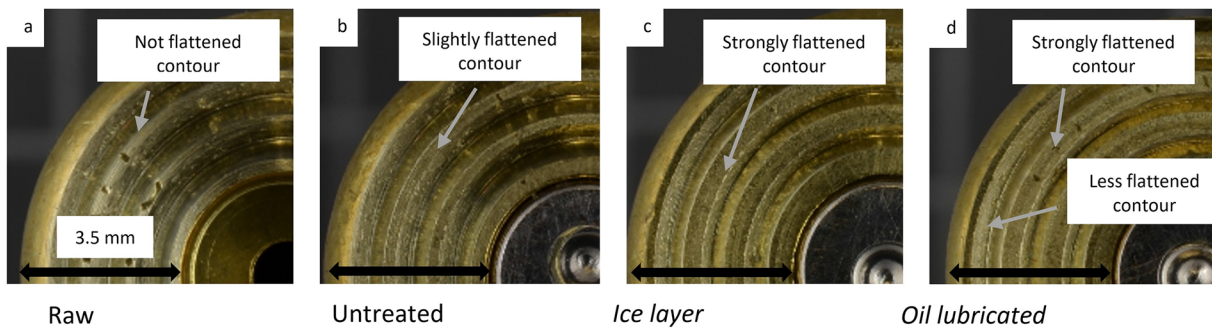

FIG. 12. Pictures of flattened casing heads.

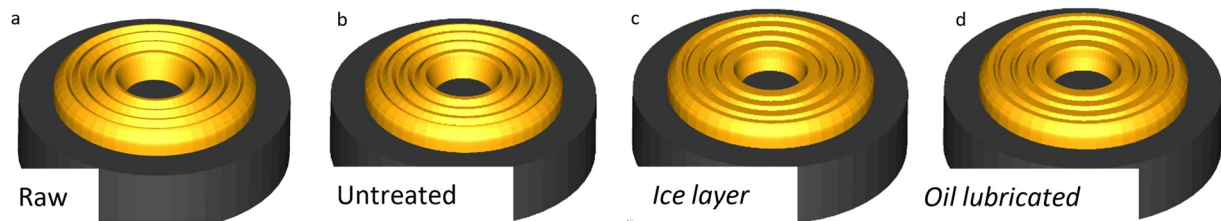

FIG. 13. FEA recalculation of the flattened casing heads.

TABLE III. Comparison between the semiquantitative FEA measurements and the force washer experiments.

| Surface state | Crusher FEA $\overline{F_{peak}}$ (kN) | $\overline{F_{peak}}$ from force washer (kN) |
|----------------|---|---|
| Untreated | 35 | 40 |
| Ice layer | 58 | 56 |
| Oil lubricated | 51 | 56 |

were compared with the force-washer measurements. The *oil lubricated* casing showed a less significant flattening of the casing head. However, this might be due to the intrinsic force spread of this caliber (338 Lapua Mag.). This is interesting since the flattening of the casing head might also lead to different internal ballistics or, in the worst-case scenario, affect the obturation process even further. Such an effect was not observed in the present study. Figure 13(a) shows the setup of the FEA, a rigid structure (black bearing) presses a simplified ductile case head against a rigid plate which is not represented. The results of the FEA are presented in Fig. 13 for the three surface states, and the comparison is given in Table III. The crusher FEA average peak-force ($\overline{F_{peak}}$) analysis is remarkably close to the measured $\overline{F_{peak}}$ by the force washer, and evidence of this is given in Table III.

CONCLUSION

This contribution investigated the effect of casings and surface states on the push-out force and transmitted impulse. Seven casings (50 Browning, 375 SWISS P, 338 Lapua Mag., 7.5 × 55 Suisse, 308 Win., 223 Rem., and 9 mm Luger) and three surface states (untreated, *ice layer*, and *oil lubricated*) were selected. We established the push-out force, and transmitted impulse often depends on the surface state. Using lubricants such as water or oil increases the average peak-force ($\overline{F_{peak}}$) up to a factor of 3.5 and affects the obturation process. These are safety-relevant features since a good obturation process is necessary to ensure the functionality of a weapon. However, large, oscillating, and unpredictable loads on a breech bolt may lead to its breakage and harm the operator severely.

We demonstrated that our proposed measurement system is suitable for analyzing a wide range of forces and impulses in small-arms weapon systems. It has been validated using a case-head crusher method, aided by FEA. The three different surface states: untreated, *ice layer*, and *oil lubricated*, showed that already small

changes in the ammunition surface have a significant influence on the push-out force and so on the obturation process. The geometry of the casing, also, influences the push-out force to a major extent, which is true for all sizes of bottleneck casings. The investigated non-bottlenecked casing (9 mm Luger) behaves differently concerning the overall spread of the momentum or push-out force. The acquired results can be used to estimate the maximum force at the breech bolt, which is a very important and safety-critical factor in the design and operation of a weapon.

The dispersion of the impulse is reduced in all surface-treated bottleneck casings. This is a strong sign that for the lubricated surface state, no stick-slip phenomenon occurs and that the obturation process has a minor influence on the push-out force.

The recommendation to users is to apply lubricant during barrel maintenance but to remove the lubricant before firing. To weapon manufacturers, the relevant recommendation is that a weapon should be capable of withstanding at least the maximal possible force which depends on the maximal possible peak pressure and the diameter of the case head. A gap between the breech bolt and casing head leads to strong collisions between the two during weapon firing.

ACKNOWLEDGMENTS

I want to express my thanks to RUAG Ammotec AG, Switzerland, for making the test facilities available. The use of measurement devices would not have been possible without the great help of Markus Gruenig and Gregoire Pache. I am also grateful to Markus Hofmann and Peter Biedermann, who contributed their expertise in the “casing crusher method” and FEA simulation.

REFERENCES

- W. H. Squire and R. E. Donnard, “An analysis of 5.56 mm aluminium cartridge case burn-through phenomenon,” National Technical Information Service, No. AD-750, pp. 385–399, 1972.
- D. Carpenter, H. Engel, B. Recchia, and P. Shipley, “Ballistic sealing, component retention, and projectile launch control for an ammunition cartridge assembly,” U.S. patent US20140000471 (2 January 2014).
- B. Peterson, E. Carlson, A. Moser, and H. Lawrence, “Projectile assembly with stabilization enhancement,” U.S. patent US9046332B2 (10 July 2014).
- T. Heitmann and T. Niemeyer, “Case base for large-caliber ammunition,” U.S. patent US6408764 (25 June 2002).
- U. Wagner, H. J. Limburgerhof, K. Henrici, H. Kuessner, K. Volkamer, and E. Fuerst, “Self-obturing, expellable cartridge case,” U.S. patent US3759184A (18 September 1973).

- ⁶R. Aida, "Measurement of coefficient of static friction of metals," *Sci. Rep. Res. Inst., Tohoku Univ., Ser. A* **2**, 380–395 (1950).
- ⁷M. A. Chowdhury, D. M. Nuruzzaman, A. H. Mia, and M. L. Rahaman, "Friction coefficient of different material pairs under different normal loads and sliding velocities," *Tribol. Ind.* **34**(1), 18–23 (2012).
- ⁸M. Paliy, O. M. Braun, and S. Consta, "The friction properties of an ultrathin confined water film," *Tribol. Lett.* **23**(1), 7–14 (2006).
- ⁹D. K. Kankane and S. N. Ranade, "Computation of in-bore velocity-time and travel-time profiles from breech pressure measurements," *Def. Sci. J.* **53**(4), 351–356 (2003).
- ¹⁰J. T. South, K. Dipak, and M. Minnicino, "Small caliber modeling from design to manufacture to launch," in *23rd International Symposium on Ballistics* (International Ballistic Society, 2007), No. April, pp. 557–564.
- ¹¹D. F. Allsop, *Brassey's Essential Guide to Military Small Arms: Design Principles and Operating Methods* (Brassey's, 1997).
- ¹²L. Elkarous, M. Pirlot, J.-C. Golinval, and M. Maldague, "Investigation on gas pressure measurement inside small Caliber weapons with piezoelectric transducers," *Meas. Sci. Conf.* **2012**, 1–8 (2012).
- ¹³G. Langer, "Neue polizeimunition," *PVT*, No. 1166, pp. 1–3, 2004.
- ¹⁴M. Thommen, *Browning Machine Gun, Caliber .50 12, 7 mm Mg 64* (Gesellschaft für Waffen und Militaria, 2006).
- ¹⁵D. Gubernat and C. Fischer, "Explicit finite element model for determining influence of cartridge case material properties on small caliber weapon function," in *Proceedings of the 26th International Symposium on Ballistics* (International Ballistic Society, 2011), pp. 806–817.
- ¹⁶J. J. Ritter, R. A. Beyer, and A. Canami, *In-Chamber Primer Force and Case Pressure Measurements of the 5.56-mm Cartridge* (U.S. Army Research Laboratory, 2012), Vol. ARL-TR-586, No. January.
- ¹⁷"CIP (Commission Internationale Permanente pour l'épreuve des Armes à Feu Portatives)," Bruxelles, p. Ann., 2019.
- ¹⁸"American National standard voluntary industry performance standards for pressure and velocity of shotshell ammunition for the use of commercial manufacturers," American National Standards Institute, 2015.
- ¹⁹AEP-97, Multi calibre manual of proof and inspection (M-C MOPI) for 5.56 mm, 7.62 mm, 9 mm and 12.7 mm ammunition, Vol. 0023, No. December 2013, 2014.
- ²⁰C. E. Waters, "Technologic Papers Bureau of Standards," p. 26, 1921.
- ²¹F. I. Du Pont, "Ballistic gun," U.S. patent US815468 (4 November 1905).
- ²²L. Elkarous, F. Coghe, M. Pirlot, and J.-C. Golinval, "Experimental techniques for ballistic pressure measurements and recent development in means of calibration," *J. Phys.: Conf. Ser.* **459**(1), 012048 (2013).
- ²³L. White and J. Siewert, "Final report of the rifling profile push test," No. June, 2007.
- ²⁴"Klübersynth MZ 4-17," pp. 3–4, 2014.
- ²⁵"Defence Standard 05-101 Part 1 Proof of Ordnance, Munitions, Armour and Explosives," No. 1, Ministry of Defence, 2005.
- ²⁶C. Jarne, "An heuristic approach to obtain signal envelope with a simple software implementation," *An. AFA* **29**, 51–57 (2017).
- ²⁷M. Muster, A. Hameed, and D. Wood, "Dynamic qualitative bolt force measurements for investigating influence factors on the pushout effect of small calibre ammunition," *AIP Adv.* **9**(6), 065020 (2019).
- ²⁸P. De Micheli, A. Settefrati, S. Marie, J. Barlier, P. Lasne *et al.*, "Towards the simulation of the whole manufacturing chain processes with FORGE[®]," NEMU 2015—New Developments in Forging Technology, May 2015, Fellbach, Germany, hal-01247710.