

Journal of Testing and Evaluation

Roberto Sabatini,¹ Mark A. Richardson,² Maurizio Cantiello,³ Mario Toscano,³ Pietro Fiorini,³ David Zammit-Mangion,⁴ and Alessandro Gardi⁴

DOI: 10.1520/JTE20120339

Experimental Flight Testing of Night Vision Imaging Systems in Military Fighter Aircraft

VOL. 42 / NO. 1 / JANUARY 2014

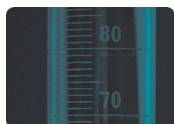

Roberto Sabatini,¹ Mark A. Richardson,² Maurizio Cantiello,³ Mario Toscano,³ Pietro Fiorini,³ David Zammit-Mangion,⁴ and Alessandro Gardi⁴

Experimental Flight Testing of Night Vision Imaging Systems in Military Fighter Aircraft

Reference

Sabatini, Roberto, Richardson, Mark A., Cantiello, Maurizio, Toscano, Mario, Fiorini, Pietro, Zammit-Mangion, David, and Gardi, Alessandro, "Experimental Flight Testing of Night Vision Imaging Systems in Military Fighter Aircraft," *Journal of Testing and Evaluation*, Vol. 42, No. 1, 2014, pp. 1-16, doi:10.1520/JTE20120339. ISSN 0090-3973

ABSTRACT

This paper describes the research and experimental flight test activities conducted by the Italian Air Force Official Test Centre (RSV), in collaboration with Alenia Aermacchi and Cranfield University, in order to confer night vision imaging systems (NVIS) capability to the Italian TORNADO Interdiction and Strike and Electronic Combat and Reconnaissance aircraft. The activities included design, development, test, and evaluation activities, including night vision goggle (NVG) integration, cockpit instruments, and external lighting modifications, as well as various ground test sessions and a total of 18 flight test sorties. RSV and Litton Precision Products were responsible for coordinating and conducting the installation of the internal and external lights. Particularly, an iterative process was established allowing in-site rapid correction of the major deficiencies encountered during the ground and flight test sessions. Both single-ship (day/night) and formation (night) flights were performed, with testing activities shared among the test crews involved, allowing for a redundant examination of the various test items by all participants. An innovative test matrix was developed and implemented by RSV for assessing the operational suitability and effectiveness of the various modifications implemented. Also important was the definition of test criteria for Pilot and Weapon Systems Officer workload assessment during the accomplishment of various operational tasks during NVG missions. Furthermore, the specific technical and operational elements required for evaluating the modified helmets were identified, allowing an exhaustive comparative evaluation of the two proposed solutions (i.e., HGU-55P and HGU-55G modified helmets). The initial compatibility problems encountered were progressively mitigated by incorporating modifications in both front and rear cockpits at various stages of the test campaign. This process allowed considerable enhancement of the TORNADO NVIS configuration, giving good medium- to

Manuscript received November 26, 2012; accepted for publication June 12, 2013; published online October 21, 2013.

¹ Dept. of Aerospace Engineering, Cranfield Univ., Cranfield, Bedford MK43 0AL, United Kingdom (Corresponding author), e-mail: r.sabatini@cranfield.ac.uk

² Cranfield Univ. – DAUK, Shrivenham, Swindon SN6 8LA, United Kingdom.

³ Air Staff, Italian Ministry of Defense, Rome 00185, Italy.

⁴ Dept. of Aerospace Engineering, Cranfield Univ., Cranfield, Bedford MK43 0AL, United Kingdom.

high-level NVG operational capability to the aircraft. Further developments also include the internal/external lighting for the Italian TORNADO “Mid-Life Update” and other programs such as AMX aircraft internal/external light modification/testing and the activities addressing low-altitude NVG operations with fast jets (e.g., TORNADO, AMX, MB-339CD), with a major issue being the safe ejection of aircrew with NVG and NVG modified helmets. Two options have been identified for solving this problem, namely, the modification of the current Gentex HGU-55 helmets and the design of a new helmet incorporating a reliable NVG connection/disconnection device (i.e., a mechanical system fully integrated in the helmet frame) with embedded automatic disconnection capability in case of ejection. Other relevant issues to be accounted for in these new developments are the helmet dimensions and weight, the NVG usable field of view as a function of eye-relief distance, and the helmet’s center of gravity (moment arms) with and without NVG (effect on aircrew fatigue during training and real operational missions).

Keywords

night vision imaging systems, night vision goggles, NVG compatibility, military avionics systems

Introduction

In recent years, the Italian Air Force (ITAF) has set requirements for night vision imaging systems (NVIS) to be integrated on TORNADO Interdiction and Strike (IDS) and Electronic Combat and Reconnaissance (ECR) aircraft for operational missions at medium and high altitudes.

The initial operational capability (i.e., operational certification for employment in peace-keeping operations) was achieved by the Italian Air Force Official Test Centre (RSV) after a ground and flight test campaign (three ground sessions and six flight test sorties) conducted on modified aircraft interior and external lighting configurations using AN/AVS/9 (F4949) night vision goggles (NVGs) manufactured by ITT-Night Vision. Successively, the full technical/formal process of avionics certification was undertaken under the direction of the Italian Ministry of Defense Aeronautical Armaments Certification Authority (Armaereo). The related flight test activities were conducted by the Italian Official Flight Test Centre with participation of the Alenia Aermacchi S.p.A. Flight Test Department. During the testing, Cranfield University provided technical advice regarding the mathematical models and analytical tools required for NVIS performance prediction and evaluation. The specific objectives of the TORNADO ground and flight test activities were the following:

- Internal and external lighting day and night evaluation with and without N/AVS/9 NVG (F4949)
- Workload assessment in single-ship and formation flights
- Ergonomic and operational evaluation of HGU-55P and HGU-55G modified helmets
- N/AVS/9 NVG (F4949) cockpit stowage evaluation
- Determination of the TORNADO-NVIS combination resolution characteristics
- Determination, via ground tests and analysis, of the TORNADO-NVIS range performance

After a brief overview of NVIS technology, this paper describes the design, development, test, and evaluation activities performed, with a special focus on cockpit design and ground/

flight test methods developed and progressively refined throughout the activity.

NVIS Technology Overview

The Image Intensifier (I^2) is the core element of NVIS systems. I^2 devices are electro-optic (EO) systems used to detect and intensify reflected energy in the visible and near-infrared regions of the electromagnetic spectrum. They require some external illumination in order to operate because the image quality is a function of the reflective contrast. The performances of I^2 devices are also dependent on atmospheric and environmental conditions. Particularly, penetration through moisture can be quite effective (especially relative to other EO devices, such as FLIR systems), whereas smoke, haze, and dust can significantly reduce I^2 performance. The signal-to-noise ratio (SNR) is the parameter commonly used to characterize I^2 system performance.

Generation I (GEN I) NVGs were introduced into service in the mid-1960s during the Vietnam War. They used starlight scopes based on electron acceleration (i.e., no microchannel plates [MCPs]). Therefore, they were characterized by high power requirements and tube gains between 40 000 and 60 000. Multiple staging, required to increase gain, often determined the increase in image distortion, and the overall systems were large/heavy (i.e., not suitable for head mounts). Furthermore, GEN I systems were very susceptible to blooming, and the mean time before failure (MTBF) of a typical GEN I NVG was on the order of about 10 000 h.

Generation II (GEN II) NVGs were introduced in the late 1960s and were small enough to be head mounted. They used electron multiplication (i.e., MCP) with increased tube gain, reduced power requirements, and reduced size/weight. Furthermore, the new I^2 technology reduced distortion and blooming (confined to specific MCP tubule halos). Typical GEN II systems were the AN/PVS-5 ground system and the AN/AVS-5 A system modified for aircraft usage. The MTBF of typical GEN II

FIG. 1 Relative responses of NVGs and the human eye.

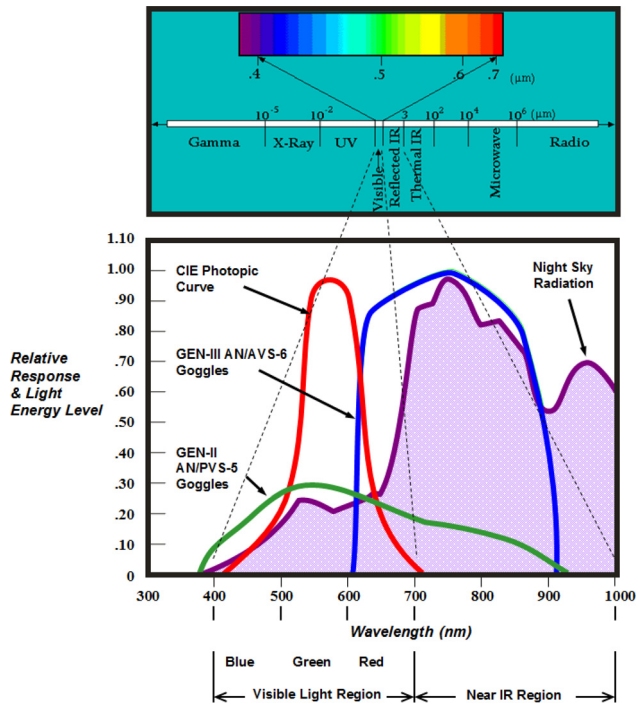

systems was on the order of about 2000 to 4000 h (worse than GEN I), the tube gain was approximately 10 000, and there was no inherent resolution improvement with respect to GEN I systems.

Improved photocathode performance, obtained via the use of gallium arsenide (GaAs) components, led to a substantial improvement in spectral response with Generation III (GEN III) systems. GEN III matches night sky radiation better than GEN I and GEN II systems and can operate in the absence of

moonlight (starlight capability). Improved MCP performance was obtained with aluminum oxide coating, which decreases ion hits and increases MTBF (>10 000 h). Today, GEN III systems are widely used in most ground and aircraft applications. **Figure 1** shows the relative responses of the GEN II/GEN III NVG systems and the human eye, together with the average night sky radiation [1,2]. The improvement obtained with GEN III NVG systems is evident.

As illustrated in **Fig. 2**, an I² device is typically composed of the following elements:

- Objective lens
- Minus-blue filter
- Photocathode
- Ion barrier film
- MCP
- Phosphor screen
- Image inverter
- Eyepiece lens

The objective lens combines the optical elements and focuses incoming photons onto the photocathode (inverted image). In most airborne NVGs, the objective lens is coated with a minus-blue filter (necessary for compatible cockpit lighting). It focuses from several inches to infinity (depending on the NVGs). Particularly, in airborne applications, infinity focusing is used in order to obtain the following:

- NVG external viewing
- Look-under/around NVGs for cockpit and instrument viewing

In airborne NVGs, a minus-blue filter is applied inside the objective lens. Its purpose is to reject visible light and prevent other specific wavelengths from entering the image intensifier. Therefore, the minus-blue allows the use of properly emitting/

FIG. 2 Architecture of an image intensifier.

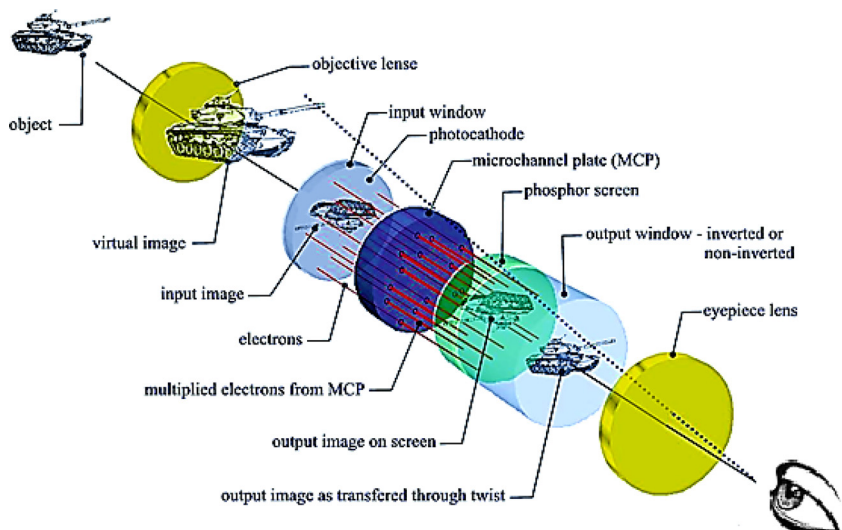

filtered lighting to illuminate the cockpit for viewing underneath the goggles. There are three different classes of NVG objective lens filters:

- Class A: blocks below 625 nm (blue/green)
- Class B: blocks below 665 nm (blue/green/reduced red), which allows the use of color displays
- Class C (leaky green), which incorporates notch cut-outs to permit viewing of specific wavelengths

The photocathode (PC) converts light energy (photons) to electrical energy (electrons). The PC inner surface is coated with a photosensitive material. In particular, we list the following materials used in GEN I/II and GEN III systems:

- GEN I/II: S-20 multi-alkali compound, sensitive between 400 and 850 nm (peak sensitivity at 500 to 600 nm)
- GEN III: GaAs, sensitive from 600 to 900 nm (impact of photons causes release of electrons)

Typical PC luminous sensitivity figures are 250 to 550 $\mu\text{A}/\text{lm}$ for GEN II systems and 1000 to 1800 $\mu\text{A}/\text{lm}$ for GEN III systems. As illustrated in Fig. 3, GEN III I² tubes are currently fabricated with a so-called ion barrier film. This film extends tube life (protects the PC) but reduces the system performance (i.e., degrades SNR).

The MCP is a thin wafer (about 1 mm) containing various millions of glass tubes or channels (typically 4×10^6 to 6×10^6). Electrons from the PC enter the MCP tube (tube walls are coated with a lead compound rich in electrons), which is tilted (about 5°) to ensure that the electrons impact the wall (Fig. 4). When an electron impacts the tube wall, more electrons are

FIG. 3 GEN III I² tube.

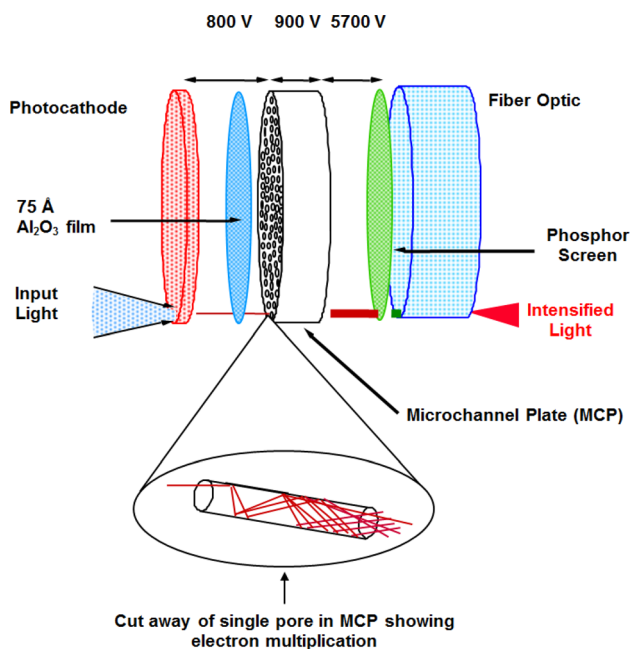
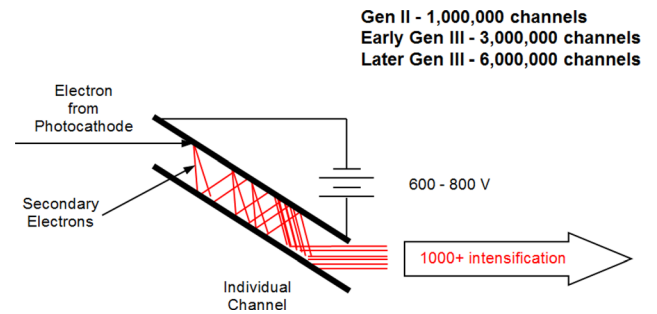

FIG. 4 MCP working principle.



released, resulting in a cascade process. Electrons are then accelerated toward the phosphor by an electrical potential differential (positive pole at phosphor). The ultimate output is the number of electrons and their velocity. The resolution is a function of the number of MCP tubes.

The phosphor screen is a thin layer of phosphor at the output of the MCP. Phosphor emits light energy when struck by electrons (electroluminescence). Light emitted by phosphor creates a visible (green) image.

The image inverter (INV) is a bundle of millions of light-transmitting fibers. The bundle rotates 180° to reorient the image (fiber optic twist). It also collimates the image for correct positioning at the viewer's eye. Problems in INV manufacturing and installation result in adverse image effects, such as distortion and a honeycomb appearance. Some NVG designs do not incorporate a fiber optic twist for reorienting the image.

The eyepiece lens is the final optical component of the NVG. It focuses the visible image on the retina of the viewer, and generally a limited diopter adjustment is allowed to permit some correction for individual vision variations. In general, corrective lenses must still be worn by users (the system does not correct for astigmatism). Most GEN II systems have a 15-mm eye relief and a nominal 40° field of view (FOV). GEN III systems typically have a 25-mm nominal eye relief that provides the same 40° FOV while also enhancing the viewer's ability to look under/around the NVG.

SNR is a measure of image intensifier performance (a result of the image intensification process). SNR for NVGs is defined as the ratio of electrons produced by ambient light (signal) to stray electrons (noise). Improved performance (larger SNRs) is produced by increasing the ambient light and/or improving the I² (e.g., increasing PC sensitivity and decreasing the space between the elements).

Night Vision Imaging System Compatibility Issues

Intensified imagery of the outside scene is of primary importance to the aircrew. Incompatible light from cockpit sources

FIG. 5

NVG model AN/AVS/9 F4949P.

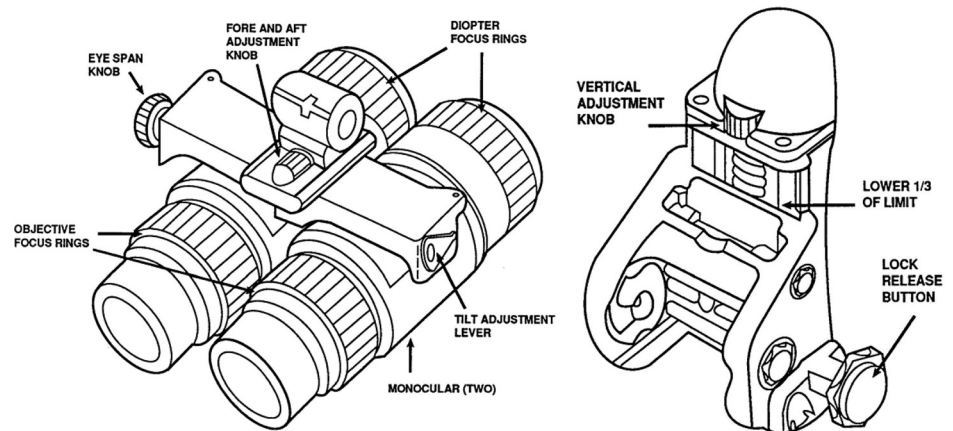

and external lights are detected by the NVGs and intensified, reducing the NVG gain. The resulting degraded image quality might not be readily apparent to the aircrew.

NVG-compatible lighting results in instruments and displays being easily read with the unaided eye at night. However, all instruments must still be readable during the day. NVG-compatible lighting is often invisible to the NVG, whereas “friendly” lighting might be visible to the goggles without changing the gain state of the goggle. Typically, NVG-compatible instruments and displays only emit wavelengths to which the eye is most responsive (i.e., little red and no near-infrared [IR] emission).

There are basically two different implementation methods that can be adopted for integrating NVG-compatible lighting in the cockpit. These methods are the following:

- Permanent lighting, including integral instrument/display lighting, post and bezel lighting, and food lighting using existing aircraft light fixtures or light-emitting diode (LED)-based light sources
- Temporary lighting, including chemical light sticks and LED wiring harnesses

Also, NVG-compatible external lights can be used in order to increase mission effectiveness, increase flight safety, and decrease aircraft vulnerability (IR covert mode). In this case, there are basically two different approaches possible:

- Introducing new equipment, including conventional/filtered, electroluminescent, and LED technologies
- Retrofitting existing lights, including filtering and modifying the existing light source

Another important aspect to be considered with NVIS-compatible aircraft developments is the NVG-helmet

integration. Particularly, the following are the main goals to be achieved:

- Reduce the NVG-helmet moment arms
- Reduce the weight
- Maximize usage of the available FOV (considering eye relief, exit pupil, etc.)
- Allow the use of various types of visors (including laser protection visors)

Description of Test Equipment

The test activities were carried out using NVG model AN/AVS/9 F4949G (P/N 264359-8), produced by ITT-Night Vision (Fig. 5). This is a GEN III NVG with a class B filter and 40° nominal FOV.

The goggles were installed on both Gentex HGU-55/G and HGU-55/P standard helmets using ITT Night Vision Helmet Modification Kit NSN 5340-01-442-641, as illustrated in Figs. 6 and 7.

The great majority of the TORNADO IDS/ECR cockpit displays, control panels, and lights were modified by filtering or substituting the existing light sources in order to obtain NVG-compatible emissions. Also, the aircraft external lights were modified, introducing an NVG-friendly (IR emission) functional mode and adding new functionalities to the already existing visible lights. The new functionalities incorporated into the aircraft external lighting system are summarized in Table 1.

In particular, a new control box was installed in the cockpit allowing the pilot to select from among the various external light functional modes. Five different codes, all square wave in nature (codes 1, 2, 3, 4, and C in Fig. 3), were programmable in

FIG. 6 Modified HGU-55/P helmet with NVGs installed.

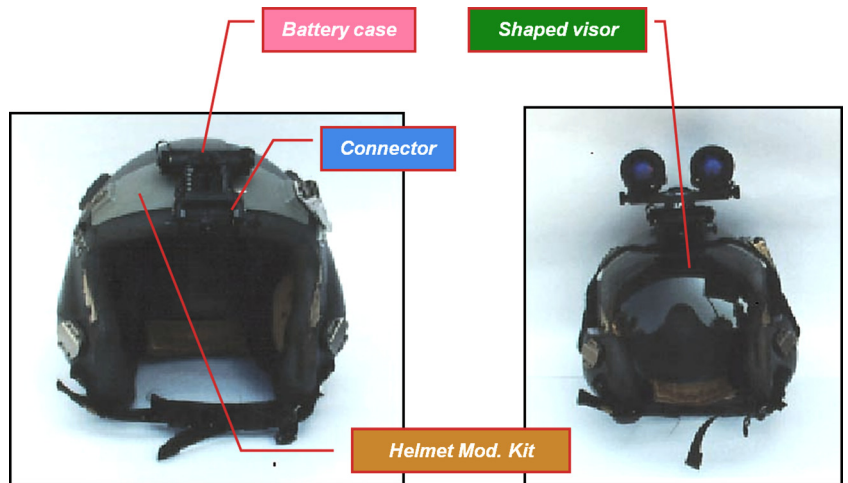

the control box (using an electrically programmable read-only memory). One of these codes was programmed with equal on and off times, and the other codes were programmed according to aircrew requirements, selecting code sequences with flash repetition frequencies and flash durations well discernible in flight.

During the flight test activities, after a large number of modifications had been introduced into the TORNADO IDS/ECR front and rear cockpits, it was observed that certain areas of the front/rear main instrument panels and of the front/rear left and right consoles were not sufficiently illuminated by self-contained and/or general purpose cockpit lighting. Therefore, it was decided to test a “finger light” in both front and rear cockpits. The finger light FINGERSTAR (P/N 4790-NF-01 A) used in the trials had both IR and visible emissions available, selectable by using a finger-switch located on an adjustable (for the left or right hand) switching rail.

Test and Analysis Methodology

Before the flight tests, ground test activities were carried out both in-hangar and outdoors. The in-hangar tests were performed in accordance with the Federal Aviation Administration NVIS Compatibility Evaluation guidelines [3], using an improved visual acuity chart (VAC) board that is described in detail below. The pool of evaluation subjects consisted of five combat-ready aircrews, including three experienced test pilots and two test navigators, with more than 2500 flying hours attained and of various ages. A hangar having adequate space for the test equipment was completely sealed from all light sources. The employed VAC board was illuminated with a movable artificial light source capable of illuminating the acuity chart from various distances at levels exceeding the 0.08 and 0.26 lux_(12 in) range [3].

The spatial resolutions attainable with the F4949 visors in the various sectors of the TORNADO canopy (normal sectors for external clearing) were measured. This was done by adopting the U.S. Navy Test Pilot School (USNTPS) bar pattern resolution method [4], and in particular by employing a USNTPS 20/20–20/70 standard square-wave grating pattern NVG resolution board as a VAC. A custom pattern resolution board was prepared (Fig. 8) composed of 16 groups of bars with dimensions and spacing corresponding to visual acuities between 20/70 and 20/20.

The spatial frequencies (cycles per millirad) corresponding to various two-dimensional (2-D) discrimination levels were determined for the F4949 system used on TORNADO in the various sectors of the aircraft canopy using the VAC board shown in Fig. 8, together with the VAC illuminator and a light meter. Using these experimental data, it was possible to calculate the detection, recognition, and identification ranges of the NVG system for targets of given aspect dimensions located in

FIG. 7 Modified HGU-55/G helmet with NVGs installed.

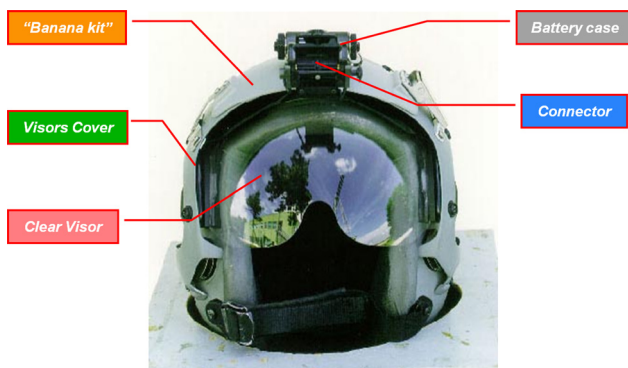

TABLE 1 External lighting system functions.

Control Panel Setting				Visible Emission			Infrared Emission		
On/Off	Bright/Dim	Visible (VIS)/Infrared (IR)	Code	Tail Light	Wing Tip	Intake	Tail Light	Wing Tip	Intake
On	Bright	VIS	C	PUNG	PUNG	PUNG	Off	Off	Off
On	Bright	VIS	1, 2, 3, 4	1, 2, 3, 4	1, 2, 3, 4	PUNG	Off	Off	Off
On	Dim	VIS	C	Steady (dim)	Steady (dim)	PUNG (dim)	Off	Off	Off
On	Bright	IR	C	Off	Off	Off	PUNG	PUNG	Off
On	Bright	IR	1, 2, 3, 4	Off	Off	Off	1, 2, 3, 4	1, 2, 3, 4	Off
On	Dim	IR	C	Off	Off	Off	Steady (dim)	Steady (dim)	Off

certain regions of the pilot and weapon systems officer (WSO) external clearing scanning patterns.

Before the on-board ground tests were carried out, a preliminary session was performed by the same aircrews, equipped with NVGs, positioned on the ground at a distance of 25 ft from the VAC board (illuminated by the artificial light source). In this condition, the resolved resolution patterns were annotated. During the successive on-board tests, the distance between the pilot/WSO reference eye position (REP) and the VAC board was set according to the specification [3] and was rotated about the REPs as shown in Fig. 9. Particularly, the following pilot/WSO sectors were considered:

- Maximum rear (field-of-regard limit)
- Lateral sector 90°
- Lateral sector 60°
- Lateral sector 15° to 30°
- Pilot head up display (HUD) (0° to 15°)

In each relevant position, the VAC board was rotated in four different positions as shown in Fig. 10. In each case, the pilot/WSO's ability to resolve the various groups of bars was recorded.

The outdoor ground tests were carried out in a mid-latitude summer night sky context, in both moonlit and moonless conditions, in the presence of artificial and urban skyglow. The ground-sensed illuminance range was between 0.023 lux and 0.87 lux.

FIG. 8 Square-wave grating pattern NVG resolution board (20/70-20/20).

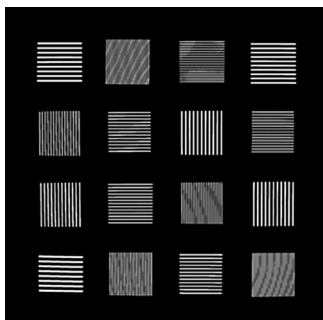

NVG range performance predictions require a mathematical model that describes the eye/brain image interpretation process. Unlike the response of an electronic circuit, the response of a human observer cannot be directly measured and can only be inferred from the results of many visual psychological experiments. The lowest level of discrimination is a distinction between something and nothing. The final level is the precise identification and description of a particular object. Between these two extremes lies a continuum of discrimination levels. In the late 1950s, Johnson studied image intensifier discrimination performance at the U.S. Army Engineering and Research Laboratories [1]. He arbitrarily divided visual discrimination into four categories: detection, orientation, recognition, and identification. Johnson's results allowed one to correlate detectability with the sensor threshold bar pattern resolution (Table 2). In Johnson's work, the (angular) spatial frequency (SF) is defined as follows:

$$(1) \quad SF = \frac{R_T}{W_{1c}}$$

where:

R_T = sensor-to-target range, and

W_{1c} = width of one cycle of target (a cycle is defined as the sum of one bar and one space on the reference target).

FIG. 9 VAC board positions for ground tests.

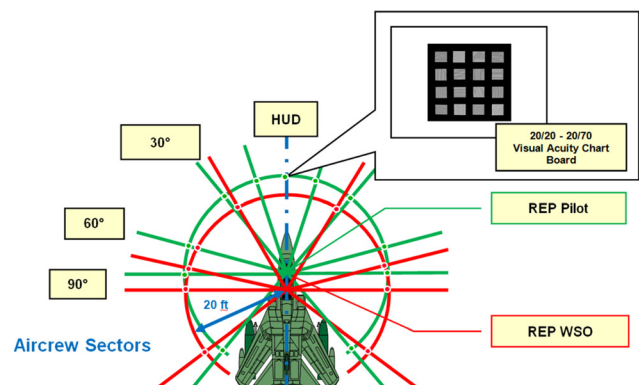
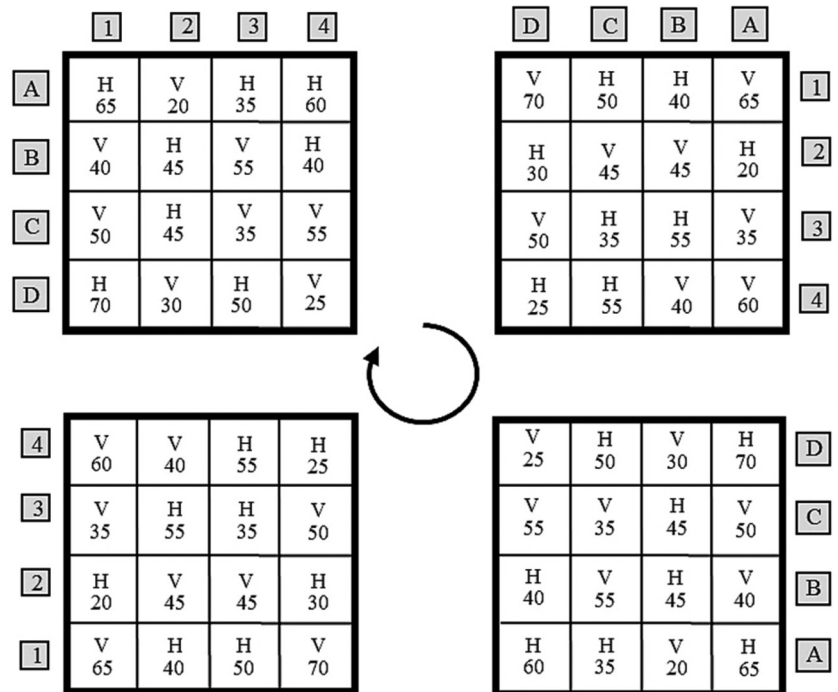

FIG. 10

Geometry of resolution ground tests.



Johnson applied the number of cycles across the target minimum dimension without regard to the orientation of the minimum dimension (his image intensifier imagery was radially symmetrical, and therefore it was reasonable for him to ignore the bar orientation). Johnson's approach, known as the equivalent bar pattern approach, became the foundation for the discrimination methodology used today.

Successive studies and tests performed at the U.S. Army Night Vision Laboratories and by the industry suggested modifications to the values originally found by Johnson. Table 3 provides the current industry standard for one-dimensional (1-D) target discrimination [2]. Orientation is a less popular discrimination level. Because current standards are based upon Johnson's work, they are labeled as the Johnson criteria, although they are not the precise values found by him.

The Johnson criteria provide an approximate measure of the 50 % probability of discrimination. Results of several tests provided the cumulative probability of discrimination, or the

target transfer probability function (TTPF). The TTPF can be used for all discrimination tasks by simply multiplying the 50 % probability of performing the task (N_{50} in Table 2) by the appropriate TTPF multiplier in Table 4 [2].

For instance, the probability of 95 % recognition is $2N_{50} = 2(4) = 8$ cycles across the target minimum dimension. Similarly, the numbers of cycles required for detection, recognition, and identification with a probability level of 80 % are 1.5, 6, and 12, respectively. An empirical fit to the data provides [4]

$$(2) \quad P(N) = \frac{\left(\frac{N}{N_{50}}\right)^E}{1 + \left(\frac{N}{N_{50}}\right)^E}$$

where

$$(3) \quad E = 2.7 + 0.7 \cdot \left(\frac{N}{N_{50}}\right)$$

TABLE 2 Summary of Johnson's experimental results.

Discrimination Level	Meaning	Cycles Across Minimum Dimension
Detection	An object is present (object versus noise)	1.0 ± 0.025
Orientation	The object is approximately symmetrical or unsymmetrical, and its orientation may be discerned (side view versus front view)	1.4 ± 0.35
Recognition	The class to which the object belongs (e.g., tank, truck, man)	4.0 ± 0.80
Identification	The object is discerned with sufficient clarity to specify the type (e.g., T-52 tank, friendly jeep)	6.4 ± 1.50

TABLE 3 Current industry criterion for 1-D discrimination (50% probability level).

Discrimination Level	Meaning	Cycles Across Minimum Dimension (N_{50})
Detection	An object is present	1.0
Recognition	The class to which the object belongs	4.0
Identification	The object is discerned with sufficient clarity to specify the type	8.0

Visual psychophysical experiments suggest that the eye response follows a log-normal distribution [5]. The probability density function is as follows:

$$p(N) = \frac{1}{\sqrt{2\pi} \cdot \log(\sigma)} \cdot e^{-(1/2)\{\log(N) - \log(N_{50})\} / \log(\sigma)}^2 \tag{4}$$

where $\log(\sigma) = 0.198$. The cumulative probability is

$$P(N) = \int_0^{\log N} p(N) d \log(N) \tag{5}$$

The empirical fit of Eq 3 and the log-normal approach (based upon a physically plausible foundation) of Eq 5 provide similar numerical results. As clutter increases, the ability to discern a target decreases. In order to account for this reduced capability, N_{50} must increase. Most studies have broadly categorized clutter into high, moderate, and low regions and defined the signal-to-clutter ratio (SCR) as

$$SCR = \frac{\max \text{ target value} - \text{background mean}}{\sigma_{\text{clutter}}} \tag{6}$$

where:

$$\sigma_{\text{clutter}} = \sqrt{\frac{1}{N} \sum_{i=1}^N \sigma_i^2} \tag{7}$$

and σ_i is the root-mean-square value of the pixel values in a square cell that has side dimensions of approximately twice the target minimum dimension. The scene is composed of N adjoining cells. The use of adjoining cells introduces a spatial weighting factor that is similar to the spatial integration performed by the eye/brain process. Clutter sizes that are equal to the object size weigh more heavily in this calculation.

TABLE 4 Discrimination cumulative probability.

Probability of Discrimination	Multiplier F_m
1.00	3.0
0.95	2.0
0.80	1.5
0.50	1.0
0.30	0.75
0.10	0.50
0.02	0.25
0	0

The results are presented in **Table 5** [6].

Field experiments demonstrated that the Johnson detection criterion applies to a “general medium to low clutter” environment. Therefore, the 50 % probability of detection in **Table 5** was normalized in moderate clutter to one cycle. These experimental findings roughly follow the empirical TTPF of Eq 2. It is convenient to use 0.5, 1.0, and 2.5 as multipliers (F_d) to N_{50} for low-, moderate-, and high-clutter environments, respectively.

In order to obtain the 2-D discrimination levels required in a 2-D performance prediction model, each value in the 1-D criteria (**Table 6**) is multiplied by 0.75. The results are presented in **Table 6**.

The U.S. Night Vision Laboratory Static Performance Model [7] uses the minimum dimension (1-D), whereas most 2-D models refer to the object critical dimension [8].

$$h_c = \sqrt{W_{TGT} \times H_{TGT}} \tag{8}$$

where W_{TGT} and H_{TGT} are the horizontal and vertical object dimensions. In this case, the number of cycles used for range performance calculations is that associated with the critical dimension h_c .

In conclusion, our 2-D range performance prediction model is summarized by the following equations:

$$R = \frac{h_c}{(N_{50-2D} \times F_d)} \times \text{SF for detection} \tag{9}$$

$$R = \frac{h_c}{(N_{50-2D} \times F_m)} \times \text{SF for recognition and identification} \tag{10}$$

TABLE 5 TTPF when clutter is present.

Probability of Detection	Multiplier F_d		
	Low Clutter: SCR > 10	Moderate Clutter: 1 < SCR < 10	High Clutter: SCR < 1
1.0	1.7	2.8	*
0.95	1.0	1.9	*
0.90	0.90	1.7	7.0**
0.80	0.75	1.3	5.0
0.50	0.50	1.0	2.5
0.30	0.30	0.75	2.0
0.10	0.15	0.35	1.4
0.02	0.05	0.1	1.0
0	0.0	0.0	0.0

*No data available.

**Estimated.

TABLE 6 Discrimination levels for the 2-D model (50% probability level).

Discrimination Level	Meaning	Cycles Across Minimum Dimension (N_{50-2D})
Detection	An object is present	0.75
Recognition	The class to which the object belongs	3.00
Identification	The object is discerned with sufficient clarity to specify the type	6.00

where:

R = predicted slant range,

h_c = target critical dimension,

SF = measured spatial frequency,

N_{50-2D} = number of cycles required for detection, recognition, and identification, and

F_m, F_d = multipliers for the various discrimination levels.

Concerning the in-flight test campaign, the same environmental illuminance conditions of the ground tests—that is, mid-latitude summer night sky in both moonlit and moonless conditions, in the presence of artificial and urban skyglow—were considered. The ground-sensed illuminance range was therefore still between 0.023 lux and 0.87 lux.

An innovative test matrix was used for assessing the operational suitability and effectiveness of the various modifications implemented in the cockpit (Fig. 11). In particular, both flight safety and the operational effectiveness/suitability of the NVIS configuration were considered in the test matrix, allowing a direct correlation between the flight test rating criteria and the standard evaluation rating scale used by RSV. This approach

was applied both to the single modified items under test (displays, lights, panels, etc.) and to the overall cockpit NVIS configuration.

Modified aircraft external lights (both visible and IR modes) were tested in formation flights (chase aircraft) including the typical IDS role maneuvers and, in particular, the following tasks:

- Tactical rejoin
- Fighting wing
- Close and battle formation
- Air-to-air refueling

Also important was the definition of criteria for pilot and WSO workload assessment during the accomplishment of various operational tasks during NVG missions (Fig. 12). A workload evaluation matrix was implemented in order to allow identification of the workload levels associated with the various pilot and WSO operational tasks during real missions. These included ferry flights, attack, formation flights, and tactical evasive/escape maneuvers. The operational tasks considered were the following:

FIG. 11

Cockpit evaluation test matrix, derived from Ref 9.

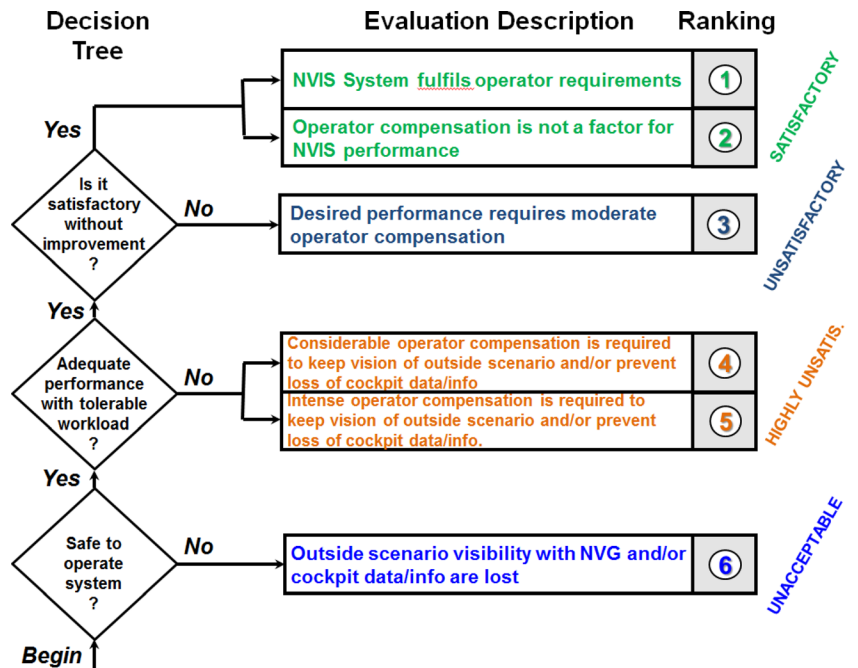
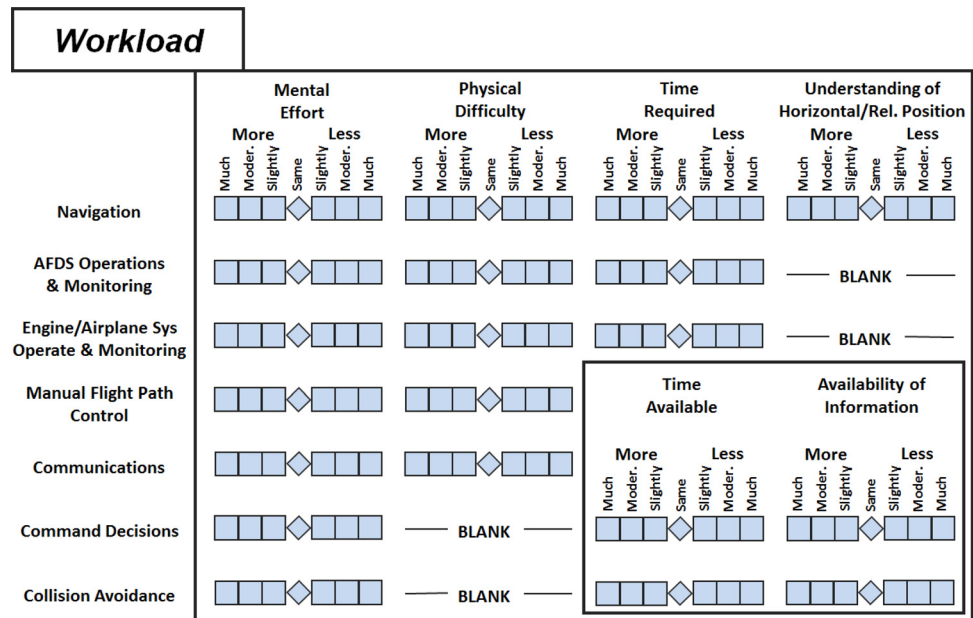

FIG. 12

Workload evaluation matrix.



- Navigation
- Automatic flight director system (AFDS) operation and monitoring
- Engine/airplane systems operation and monitoring
- Manual flight path control
- Communications
- Command decisions
- Collision avoidance

For each of the above tasks performed on the TORNADO NVG configuration, the levels of mental effort and physical difficulty, together with the time required for the specific tasks and the understanding of horizontal/vertical position (spatial orientation) during execution of the tasks, were compared with the respective levels/values found for the standard TORNADO aircraft. Furthermore, the specific technical and operational elements required for evaluating the modified helmets were identified, allowing an exhaustive comparative evaluation of the two proposed solutions (i.e., HGU-55P and HGU-55G modified helmets). These elements included measurement of the available FOV and calculation of the projected FOV area reduction (PFAR), weight/balance, comfort and stability, and crew fatigue in low- and high-dynamics flights. Furthermore, the NVG connection/disconnection devices were tested during high-dynamics maneuvers (with NVGs in both up-locked and down-locked positions).

In order to assess the operational suitability of the modified HGU-55/P and HGU-55/G helmets, the related test activities focused on the following aspects:

- Measurement of the available FOV with minimum eye relief

- Determination of the minimum PFAR
- NVG helmets' fitting and stability
- Clearance with a/c structure (NVG up-locked and down-locked)
- Fatigue in low-dynamics flight
- Fatigue in maneuvering flight
- Possible use of protective visors

Test Results

The activities on TORNADO IDS and ECR included various ground test sessions and a total of 18 flight test sorties (7 night flights and 2 day flights for each aircraft type). RSV and Litton Precision Products were responsible for coordinating and conducting the installation of the internal and external lights. An iterative process was established that allowed the in-site rapid correction of the major deficiencies encountered during the ground and flight test sessions. Both single-ship (day/night) and formation (night) flights were performed, with activities shared among the test crews involved (test pilots/WSOs), allowing for a redundant examination of the various test items by all participants. The technical results of the activity were quite satisfactory. Particularly, the internal lighting compatibility problems were progressively mitigated by incorporating modifications in both the front and rear cockpits at various stages of the development test program. This process allowed considerable enhancement of the TORNADO cockpit NVIS configurations, giving good medium- to high-level NVG operational capability to the aircraft. The Air Force Operational Certifications for both the IDS and ECR aircraft configurations were achieved by 2002.

FIG. 13 Results of the cockpit evaluation.

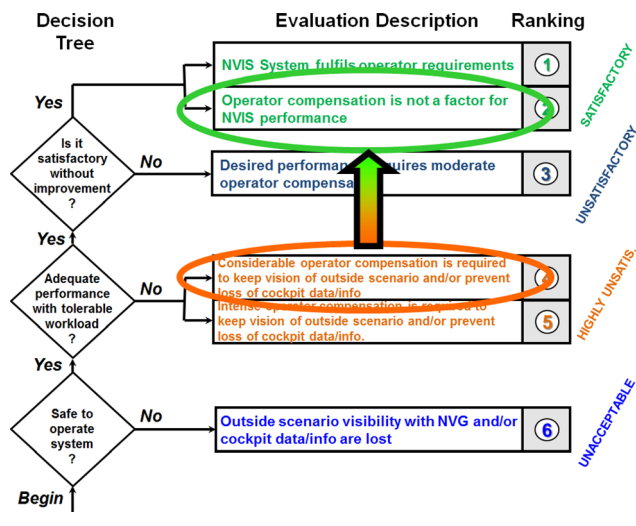

Figure 13 shows the initial and final results of the overall cockpit evaluation.

All external lighting modifications incorporated into the aircraft were satisfactory, and all medium- to high-level flight tasks required were performed successfully after an adequate level of aircrew training. Close-formation flights were some of the most demanding tasks during NVG operations, and an appropriate level of aircrew training was required in order for subjects to estimate other aircrafts' distance, altitude, and speed (depth/distance perception is severely degraded by NVGs).

The workload assessment also gave encouraging results, demonstrating that the modifications of the interior and exterior aircraft lighting increased the levels of pilot/WSO situational awareness and therefore their ability to perform operational tasks in night conditions. Medium- to high-level navigation and communications tasks were performed without a significant increase in aircrew workload, and the increase in workload experienced in AFDS/engine/airplane systems operation and monitoring was counterbalanced by the substantial

TABLE 7 Ergonomic evaluation results for the two tested helmets.

HGU-55G	HGU-55P
<p>Pros:</p> <ul style="list-style-type: none"> • Easy use of visor (protection against wind blast and canopy fragmentation during ejection) <p>Cons:</p> <ul style="list-style-type: none"> • Reduced adjustment capabilities • Greater eye-lens distance <ul style="list-style-type: none"> ○ Reduced FOV ($\geq 3^\circ$) ○ Additional disturbance ○ Increased arm ($>$fatigue) 	<p>Pros:</p> <ul style="list-style-type: none"> • Nominally fully adjustable • Full FOV (40°) available • No additional disturbance • Reduced arm of the NVGs ($<$fatigue) <p>Cons:</p> <ul style="list-style-type: none"> • Difficult use of visor • Laser visor currently not in use within the ITAF

TABLE 8 FOV and PFAR measurements.

FOV			PFAR		
HGU-55P	HGU-55G	Diff. FOV	HGU-55P	HGU-55G	Diff. PFAR
39.19	37.21	1.98	4.30%	14.44%	10.14%

reduction in workload experienced in manual flight path control, command decisions, and collision avoidance tasks (e.g., formation flights). Again, it was readily apparent during the tests that aircrew training was the key to increased flight safety and operational effectiveness in NVG operations.

The results of the NVG-helmet ergonomic evaluation are summarized in Table 7. The modified HGU-55/G helmet was heavier and less stable/balanced than the HGU-55/P helmet, and it also led to a reduced NVG FOV as a result of increased eye relief. However, the HGU-55/P helmet was not suitable for operational use because of difficulties in installing and removing the clear/laser protection visors during night operations with NVGs (flying with protection visors is required on TORNADO to protect the aircrew, in case of ejection, against windblast and canopy fragmentation).

Table 8 shows the experimental data relative to the NVG FOV and PFAR obtained with the HGU-55/G and HGU-55/P modified helmets, used by an operator with average percentiles wearing a medium-size helmet and a medium-size oxygen mask (similar results were obtained with operators having different percentiles).

Compared to the 40° nominal FOV of the F43949 system, it is evident that there was a decrease in FOV of about 0.8° for the HGU-55/P helmet and 2.8° for the HGU-55/G helmet (i.e., the HGU-55/P helmet gives a 2° increase in FOV because of reduced eye relief). With the same operator, the PFAR (i.e., reduction of imaged scene area covered by the NVGs) was about 4 % for the HGU-55/P and about 14 % for the HGU-55/G. Therefore, there was a difference of about 10 % in the area covered by the NVGs between the two helmets.

FIG. 14

Curves for FOV versus ERD and PFAR versus FOV.

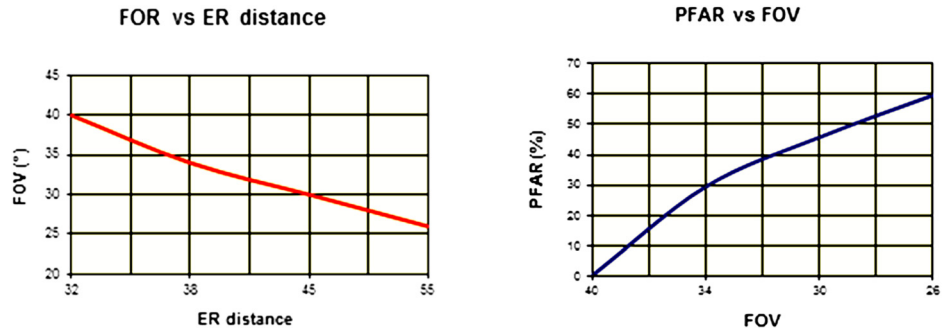

Based on the F4949 design data (provided by ITT Night Vision), Fig. 14 shows the FOV calculated as a function of the eye-relief distance and the PFAR-versus-FOV curve.

The experimental PFAR data (Fig. 15) were essentially coherent with the theoretical calculations. It is worth underlining that an eye relief distance (ER Distance) increase of 1 mm led to a 1° reduction in FOV and an increase of the PFAR of about 5 %. Compared to the ideal case of FOV = 40°, this would equate to a 20 % reduction in the area covered by the NVGs for the HGU-55/G helmet, and about a 10 % reduction for the HGU-55/P helmet.

Based on visual acuity measurements, the NVG detection, recognition, and identification range performances were calculated using Eqs 9 and 10 for different types of targets. The detection, recognition, and identification range performances were calculated with 80 %, 90 %, and 100 % probability levels.

Furthermore, the detection performances (80 %, 90 %, and 100 % probability) were also calculated in low-, medium-, and high-clutter conditions. Examples of the results obtained are shown in Fig. 16.

FIG. 15 Percentage variation of the PFAR as a function of ERD and FOV.

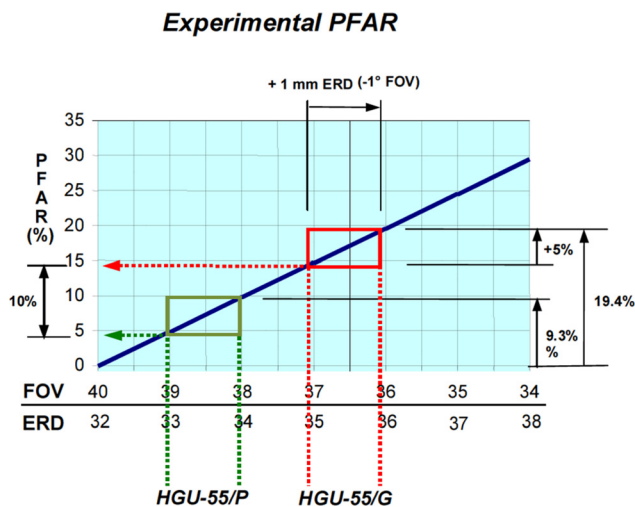
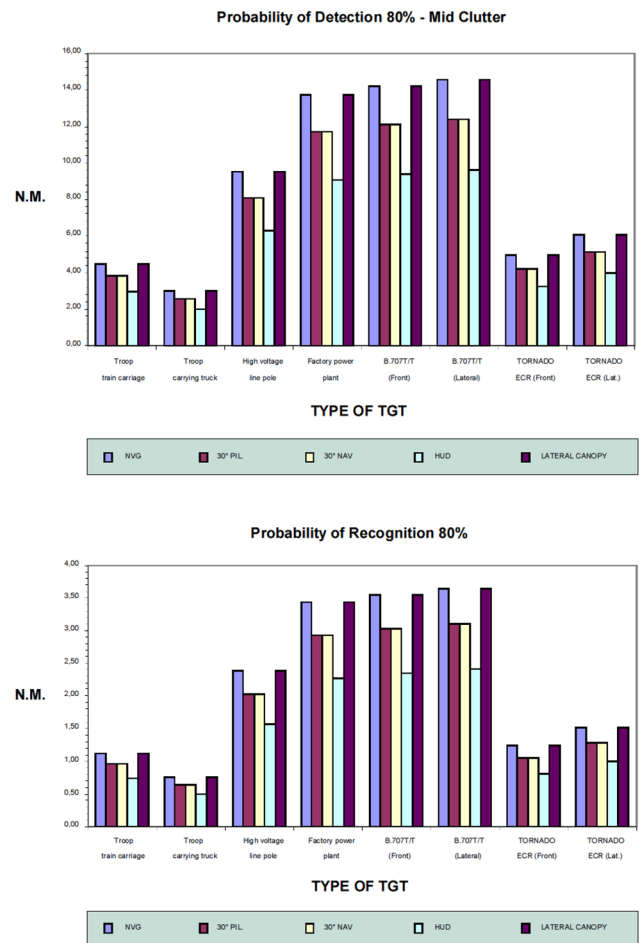

FIG. 16 Results of NVG range performance calculations.



Conclusions and Further Developments

In this paper, we have described the development and testing activities conducted on the Italian TORNADO IDS/ECR in order to confer medium- to high-level NVG operational capability to the aircraft. The TORNADO development activities addressing the aircraft's interior/exterior lighting and helmet modifications (NVG integration) were conducted by RSV and supported by the industry (Litton Presion Products). The ground and flight test activities also were conducted by RSV, with industry participation in the test flights (Alenia Aermacchi).

Particularly important for RSV was the clear identification of the technological alternatives available for aircraft modifications, as well as the definition of suitable test methods for both internal and external lighting evaluation. Also very important was the adoption of appropriate NVG performance analysis models, which led to the development of a standard PC-based data analysis tool.

The technical results of the TORNADO NVG activities were very satisfactory. In particular, the internal lighting compatibility problems were progressively mitigated by incorporating modifications in both front and rear cockpits at various stages of the development test program. This process allowed considerable enhancement of the TORNADO cockpit NVIS configurations, giving good medium- to high-level NVG operational capability to the aircraft.

The workload assessment also gave encouraging results, demonstrating that the modifications of the aircraft's interior and exterior lighting increased the levels of pilot/WSO situational awareness and therefore their ability to perform operational tasks in night conditions. However, it was readily apparent during the tests that aircrew training was the key to increased flight safety and operational effectiveness in NVG operations.

The NVG-helmet tests allowed comprehensive verification of the ergonomic and technical elements in favor of or against each of the proposed solutions (i.e., modified HGU-55/G and HGU-55/P helmets). Overall, the HGU-55/P helmet was rejected because of difficulties in installing and removing the clear/laser protection visors during night operations, and the modified HGU-55/G was selected for TORNADO IDS/ECR operations (although it was not fully satisfactory).

In conclusion, considerable experience was gained during the TORNADO NVG activities, and further developments were launched in this area, taking advantage of the technical and operational lessons learned, to increase the operational capability and safety of ITAF aircraft. Further developments include the Alenia internal/external lighting design for the Italian TORNADO "Mid Life Update" and various other Air Force programs, such as AM-X aircraft internal/external light

FIG. 17 ITT/Gentex proposed NVG helmet for TORNADO.

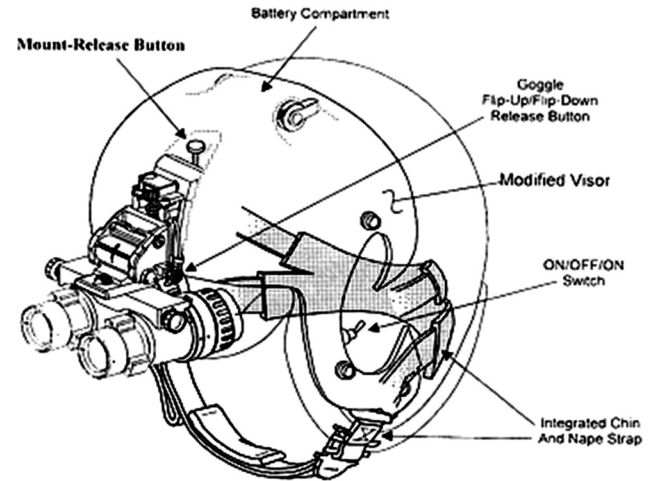

modification/testing and other activities addressing low-altitude NVG operations with fast jets (e.g., TORNADO, AM-X, MB-339CD). A major issue encountered is the safe ejection of aircrew with NVGs and NVG modified helmets. Two options have been identified for solving this problem: modification of the current HGU-55 helmets, and the design of a new helmet incorporating a reliable NVG connection/disconnection device (i.e., a mechanical system fully integrated in the helmet frame) with embedded automatic disconnection capability in case of ejection. Other relevant issues to be accounted for in these new developments are the helmet dimensions and weight, the NVG usable FOV as a function of eye-relief distance, and the helmet's center of gravity (moment arms) with and without NVGs (effect on aircrew fatigue during training and real operational missions). A pictorial representation of the system initially proposed by Gentex and ITT Night Vision in order to match the Italian and German Air Forces' TORNADO helmet requirements is shown in Fig. 17.

The ITAF requirements for a new helmet allowing safe and practical usage of the F4949P NVGs were established so that no restrictions were applied to the aircraft operational flight envelopes by the NVG system. In order to achieve this, the new development should address the following main issues:

- Maximize the operator's usage of the NVG performance
- Maximize the balancing, stability, and comfort of the new helmet
- Maximize the level of safety (normal use and ejection)

The overall goals to be achieved in the development are the following:

- No modifications of the existing F4949P NVG system
- NVGs usable in up-locked and down-locked positions
- Practical and safe connection/disconnection of the NVGs/adapters

FIG. 18 Proposed HGU-55/G NVG helmet.

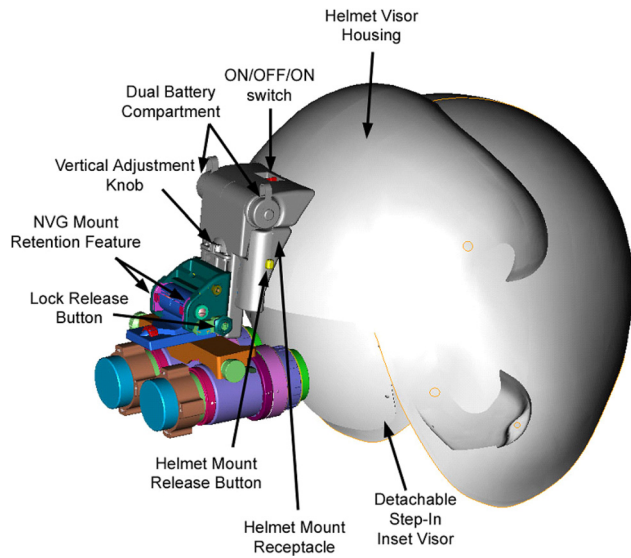

- Maximum usage of the available NVG FOV
- No protrusions on the helmet
- No helmet weight increase
- NVG-adapter moment arm minimization
- Maximum comfort and stability also under g's
- Use of helmet visors (inner clear/laser visor for NVG operations and dark outer visor for operations without NVGs)
- Availability of documentation required for helmet/adaptor qualification and certification (i.e., system performance specification, system design documentation, development test reports)

The new developments shall not include modifications of the existing F4949P NVG system. Furthermore, the NVGs should be usable in both up-locked and down-locked positions, without the possibility of NVG disconnection in these positions from the adapter-helmet. Manual disconnection of the NVGs from the adapter-helmet should be possible only in a dedicated “intermediate” position. Self-disconnection during ejection should be guaranteed independently from the NVG position.

Connection and disconnection of the F4949P NVGs, of the helmet adapter, and of the NVG-adapter block should be possible for the operator with a single action and using a single hand. In particular, the entire NVG-adapter block should be removable as one section (e.g., before ejection), the F4949P NVGs should be separately removable from the adapter-helmet (e.g., for normal stowing of the NVGs), and the adapter should be separately removable from the helmet (using the same device available for removal of the NVG-adapter block). Additional detailed requirements are as follows:

- During the initial phase of a seat ejection (i.e., acceleration phase), the NVG-adapter block should fall off the helmet without any action required on the part of the crew.
- The modified helmet-adapter should allow usage of the maximum FOV provided by F4949P NVGs.
- The helmet should be free from significant protrusions. The adapter block should be designed to minimize protrusions, so as to allow a smooth surface of the helmet-adapter combination.
- All efforts should be made to minimize the weight of the modified helmet. Particularly, it is desirable that the weight of the new helmet does not increase with respect to the current helmets, and if feasible, it should be reduced.

FIG. 19

Proposed HGU-55/P NVG helmet.

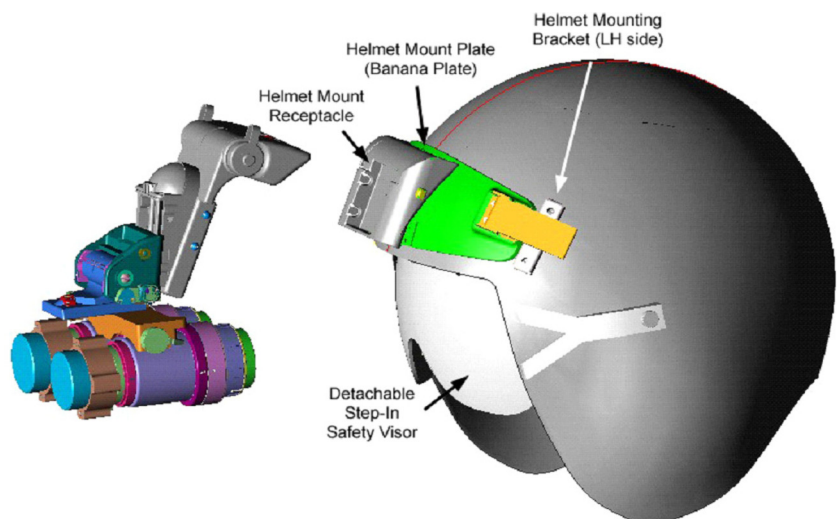

- The moment arm of the NVG-adapter block should be minimized in order to obtain a balanced helmet and to maximize the helmet's stability and fitting comfort.
- The inner part of the helmet should be modified in order to enhance the helmet's stability (also under g's) by using combined chin-nape straps or other stability-enhancing features.
- The helmet should be equipped with two visors: an inner visor (i.e., clear visor or laser visor) and an outer visor (i.e., dark visor). The F4949P NVG system will be used with the inner visor down.

Recent studies conducted by ITT-Night Vision and Gentex, in collaboration with ITAF and the Italian Ministry of Defense, have led to the NVG-helmet solutions shown in **Figs. 18** and **19**. In particular, two different technical options were identified: one based on the HGU-55/G helmet (**Fig. 18**), and another based on the HGU-55/P helmet (**Fig. 19**).

ACKNOWLEDGMENTS

The writers acknowledge the valuable contributions of Alenia Aermacchi S.p.A. and Litton Precision Products during the TORNADO IDS/ECR NVG development and flight test activities. Great thanks go to the staff of RSV for strongly supporting NVIS programs. The writers thank the aircrews and technical personnel of the Alenia Aermacchi Flight Test Department. Thanks also go to all Air Force, Alenia Aermacchi, Litton, ITT, and Gentex personnel not explicitly mentioned here who supported in different ways the TORNADO NVG development programs. A shorter version of this paper was presented at the SPIE Photonics Europe 2012 Conference, held in Brussels in March 2012.

References

- [1] Johnson, J., "Analysis of Imaging Forming Systems," *Proceedings of the Image Intensifier Symposium*, Warfare Electrical Engineering Department, U.S. Army Engineering Research and Development Laboratories, Ft. Belvoir, VA, 1958, pp. 249–273.
- [2] Ratches, J. A., "Static Performance Model for Thermal Imaging Systems," *Opt. Eng.*, Vol. 15, No. 6, 1976, pp. 525–530.
- [3] Federal Aviation Administration, *NVIS Compatibility—Ground Evaluation Setup*, Federal Aviation Administration, Washington, D.C.
- [4] Howe, J. D., "Electro-Optical Imaging Systems Performance Prediction," *Infrared and Electro-Optical Systems Handbook, Volume 4: Electro-Optical Systems Design, Analysis and Testing*, J. S. Accetta and D. L. Shumaker, Eds., Environmental Research Institute of Michigan and SPIE, Bellingham, WA, 1993.
- [5] Holst, G. C., "Applying the Log-normal Distribution to Target Detection," *Proc. SPIE*, Vol. 1689, 1992, pp. 213–216.
- [6] Schmieder, D. E. and Weathersby, M. R., "Detection Performance in Clutter With Variable Resolution," *IEEE Trans. Aerosp. Electron. Syst.*, Vol. AES-19, No. 4, 1983, pp. 622–630.
- [7] Ratches, J. A., Lawson, W. R., Orbet, L. P., Begemann, R. J., Cassidy, T. W., and Swenson, J. M., "Night Vision Laboratory Static Performance Model for Thermal Viewing Systems," *ECOM Report No. ECOM-7043*, United States Army Electronics Command (ECOM), Fort Monmouth, NJ, 1975.
- [8] Holst, G. C., *Electro-Optical Imaging System Performance*, SPIE, Bellingham, WA, 1995.
- [9] Cooper, G. E. and Harper, R. P., "The Use of Pilot Rating in the Evaluation of Aircraft Handling Qualities," *NASA TN D-5153*, National Aeronautics and Space Administration, Washington, D.C., 1969.