

Citation for published version:

Maamar BENYAMINA, Mohamed BOUHAMIDA, Tayeb ALLAOUI, Mouloud DENAI, and Rachid TALEB, 'Modeling and Control of a UPFC System Using Pole-Placement and H_{∞} Robust Control Techniques', *International Journal of Engineering and Technology*, Vol. 10 (2): 613-627, Apr-May 2018.

DOI:

[Link to issue on journal's website](#)

Document Version:

This is the Published Version.

Copyright and Reuse:

This is an open access article distributed under Creative Commons Attribution-NonCommercial-NoDerivatives 4.0 International license (CC BY-NC-ND 4.0)

<https://creativecommons.org/licenses/by-nc-nd/4.0/>

Enquiries

If you believe this document infringes copyright, please contact Research & Scholarly Communications at rsc@herts.ac.uk

Modeling and Control of a UPFC System Using Pole-Placement and H_∞ Robust Control Techniques

Maamar BENYAMINA^{1,4}, Mohamed BOUHAMIDA¹, Tayeb ALLAOUI²,
Mouloud DENAI³, Rachid TALEB⁴

¹Electrical Engineering Department, Mohamed Boudiaf University of Science and Technology, Oran, Algeria

²Electrical Engineering Department, Ibn Khaldoun University, Tiaret, Algeria

³School of Engineering and Technology, University of Hertfordshire, United Kingdom

⁴Electrical Engineering Department, Hassiba Benbouali University, LGEER Laboratory, Chlef, Algeria
benyamina.maamar@yahoo.fr, m_bouhamida@yahoo.com, allaoui_tb@yahoo.fr, m.denai@herts.ac.uk,
Corresponding author: rac.taleb@gmail.com

Abstract—FACTS (Flexible AC Transmission Systems) technology has now been accepted as a potential solution to the stability problem and load flow. The Unified Power Flow Controller (UPFC) is considered to be the most powerful and versatile among all FACTS devices. This paper presents the modeling and control of a UPFC system using pole-placement and H_∞ robust control techniques. A simulation study using Matlab/Simulink is presented to compare the performance of these control strategies and their robustness with respect to variations in the system parameters such as the inductance of the transmission line.

Keyword-UPFC, pole-placement, H_∞ Robust Control Techniques

I. INTRODUCTION

The Unified Power Flow Controller (UPFC), is among the FACTS devices that have attracted the attention of many researchers because it is capable of simultaneously and independently controlling the flow of active and reactive powers in a network. The UPFC combines a shunt compensation, (Static Compensator or STATCOM), and a series compensation (Static Synchronous Series Compensator or SSSC) and has the ability to control three parameters associated with the transit of powers namely the line voltage, the impedance of the line and the load angle. The UPFC is placed on the transmission line between the source and the load as shown in Fig. 1 [1, 2].

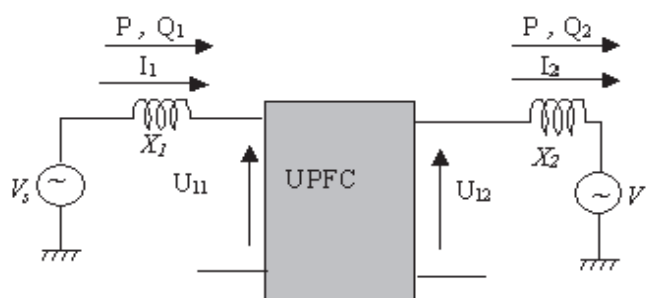

Fig. 1. Electrical network with UPFC

It consists of two voltage source converters (VSC) connected through a common DC link. The first converter (A) is connected in series and the second (B) in parallel to the line (Fig. 2). Converter A performs the main task of the UPFC by injecting an AC voltage adjustable via transformer T2. The role of converter B, is to supply or absorb the active power required by Converter A to the common DC circuit. It can also generate or absorb reactive power.

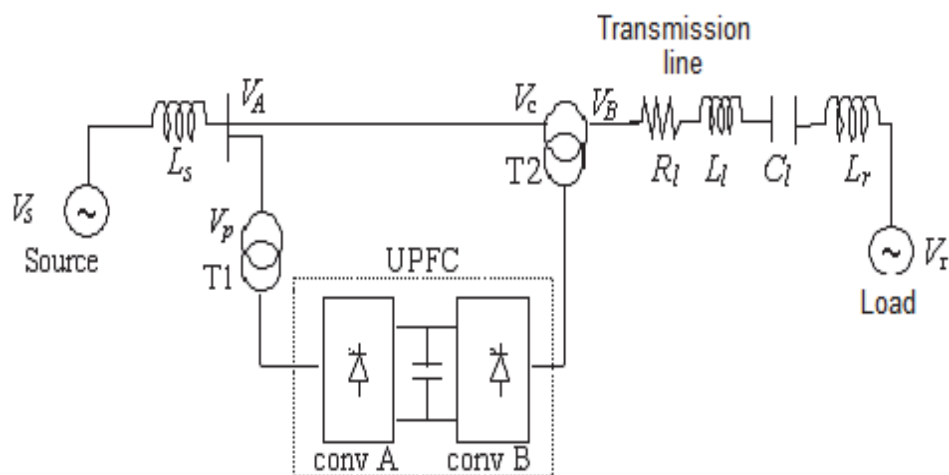

Fig. 2. UPFC components and structure

This paper presents two control design approaches: a simple decoupling controller based on pole-placement and an H_∞ robust controller formulated in the state space domain.

H_∞ robust control theory is probably the control theme which has led to the largest number of publications and greater efforts since the mid-80 s. The main reason for its popularity is because it represents a very natural way to formulate the problem of robustness.

It all started with an article by Zames [3], published in 1981 and followed by other articles [4-6]. These articles did not concern the robustness problem, but rather the disturbance rejection. It is Kimura [4] who, in 1984, formulated the first robust control problem in terms of H_∞ . Although his position of the problem is hardly different from that proposed by Doyle and Stein [7] (novelty residing in the explicit use of the H_∞ framework that allowed Kimura to solve the synthesis problem). Thanks to the important concept of the standard problem that the work of Francis Doyle and [8] were unified.

The resolution of the standard problem grew very significantly in 1988 with Glover-Doyle algorithm [9], which uses state space representation. In the solutions of the problem, they introduced Riccati equations [6, 8, 14]. This approach is employed in this paper for solving the H_∞ control problem. Robust stability is defined as the ability of a system to remain stable when subjected to perturbation such as modeling errors, measurement errors and external disturbances. Robust performance, on the other hand reflects the ability of the system to maintain the specified performance characteristics (stability, decoupling, time response...) when subjected to disturbances. Indeed, a physical system generally has non-linear characteristics that are not usually included in the model for simplification purposes. So an invariant model cannot accurately represent the reality and for this it is necessary to consider these errors in all control techniques.

The H_∞ control method is considered to be a very powerful design technique which has attracted many researchers from the electric power community.

II. MODELING OF THE UPFC

The simplified phase circuit of the UPFC is shown in Fig. 3. Using Kirchhoff's laws, we can write:

$$\begin{cases} V_{sa} - V_{ca} - V_{ra} = L_s \frac{d}{dt}(i_a + i'_a) + L \frac{di_a}{dt} + \frac{1}{C_L} \int i_a dt + Ri_a \\ V_{sb} - V_{cb} - V_{rb} = L_s \frac{d}{dt}(i_b + i'_b) + L \frac{di_b}{dt} + \frac{1}{C_L} \int i_b dt + Ri_b \\ V_{sc} - V_{cc} - V_{rc} = L_s \frac{d}{dt}(i_c + i'_c) + L \frac{di_c}{dt} + \frac{1}{C_L} \int i_c dt + Ri_c \end{cases} \quad (1)$$

L is the total inductance of the line and the load.

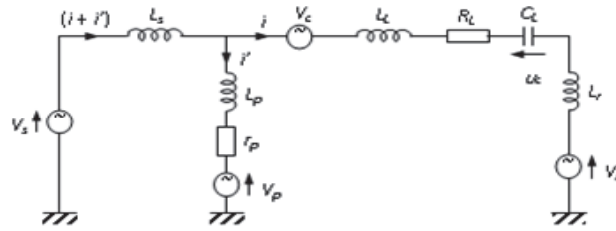

Fig. 3. Equivalent circuit of the UPFC

Using Park transformation, this system becomes:

$$\begin{cases} V_{sd} - V_{cd} - V_{rd} = L_s \frac{d}{dt}(i_d + i'_d) - \omega L_s (i_q + i'_q) + L \frac{di_d}{dt} - \omega L i_q + V_{cd} + R i_d \\ V_{sq} - V_{cq} - V_{rq} = L_s \frac{d}{dt}(i_q + i'_q) + \omega L_s (i_d + i'_d) + L \frac{di_q}{dt} + \omega L i_d + V_{cq} + R i_q \end{cases} \quad (2)$$

For the shunt compensator:

$$\begin{cases} V_{sd} - V_{pd} = L_s \frac{d}{dt}(i_d + i'_d) - \omega L_s (i_q + i'_q) + L_p \frac{di'_d}{dt} - \omega L_p i'_q + r_p i'_d \\ V_{sq} - V_{pq} = L_s \frac{d}{dt}(i_q + i'_q) + \omega L_s (i_d + i'_d) + L_p \frac{di'_q}{dt} + \omega L_p i'_d + r_p i'_q \end{cases} \quad (3)$$

For DC link:

$$\frac{1}{2} C \frac{dV_{dc}}{dt} = P_{ep} - P_e \quad (4)$$

$$P_{ep} = V_{pa} \cdot i'_a + V_{pb} \cdot i'_b + V_{pc} \cdot i'_c$$

$$P_e = V_{ca} \cdot i_a + V_{cb} \cdot i_b + V_{cc} \cdot i_c$$

P_{ep} : Active power consumption of the network through the parallel compensator and provided to the DC circuit and series compensator.

P_e : Power injected by the series compensator in the network.

Using Park transformation:

$$\frac{dV_{dc}}{dt} = \frac{3}{2CV_{dc}} (V_{pd} i'_d + V_{pq} i'_q - V_{cd} i_d - V_{cq} i_q) \quad (5)$$

Let δ and θ be the phase shifts between the reference and the converter output voltages V_c and V_p , respectively. The d-q components can be expressed as follows [6]:

$$V_{cd} = k_1 \cdot V_{dc} \cdot \cos(\delta); \quad V_{cq} = k_2 \cdot V_{dc} \cdot \sin(\delta) \quad (6)$$

$$V_{pd} = k_2 \cdot V_{dc} \cdot \cos(\theta); \quad V_{pq} = k_2 \cdot V_{dc} \cdot \sin(\theta) \quad (7)$$

Assuming that the voltages at the source and receiving end are equal and the influence of the output shunt is neglected, the previous equations become:

$$\begin{cases} L_s \frac{di_d}{dt} + L \frac{di_d}{dt} - \omega L_s i_q - \omega L i_q + u_{cd} + U_{cd} + R i_d = 0 \\ L_s \frac{di_q}{dt} + L \frac{di_q}{dt} + \omega L_s i_d + \omega L i_d + u_{cq} + U_{cq} + R i_q = 0 \end{cases} \quad (8)$$

$$\begin{cases} i_d - C_L \frac{du_{cd}}{dt} + \omega C_L u_{cq} = 0 \\ i_q - C_L \frac{du_{cq}}{dt} - \omega C_L u_{cd} = 0 \end{cases} \quad (9)$$

Rearranging (8) and (9):

$$\begin{cases} \frac{di_d}{dt} = -\frac{R}{L_T} i_d + \omega i_q - \frac{1}{L_T} (u_{cd} + U_{cd}) \\ \frac{di_q}{dt} = -\frac{R}{L_T} i_q - \omega i_d - \frac{1}{L_T} (u_{cq} + U_{cq}) \\ C_L \frac{du_{cd}}{dt} = i_d + \omega C_L u_{cq} \Rightarrow \frac{du_{cd}}{dt} = \frac{1}{C_L} i_d + \omega u_{cq} \\ C_L \frac{du_{cq}}{dt} = i_q - \omega C_L u_{cd} \Rightarrow \frac{du_{cq}}{dt} = \frac{1}{C_L} i_q - \omega u_{cd} \end{cases} \quad (10)$$

with:

$$L_T = L + L_s .$$

This system can be written in the state space form as follows:

$$\begin{cases} \dot{X} = AX + BU \\ Y = CX + DU \end{cases}$$

$$A = \begin{bmatrix} -\frac{R}{L_T} & \omega & -\frac{1}{L_T} & 0 \\ -\omega & -\frac{R}{L_T} & 0 & -\frac{1}{L_T} \\ \frac{1}{C_L} & 0 & 0 & \omega \\ 0 & \frac{1}{C_L} & -\omega & 0 \end{bmatrix} ; B = \begin{bmatrix} 0 & -\frac{1}{L_T} \\ -\frac{1}{L_T} & 0 \\ 0 & 0 \\ 0 & 0 \end{bmatrix} ;$$

$$C = \begin{bmatrix} u_{rdo} & u_{rqo} \\ u_{rqo} & -u_{rdo} \\ 0 & 0 \\ 0 & 0 \end{bmatrix}^T ; D = \begin{bmatrix} 0 & 0 \\ 0 & 0 \end{bmatrix} ; U = \begin{bmatrix} V_{cq} \\ V_{cd} \end{bmatrix} ; Y = \begin{bmatrix} P \\ Q \end{bmatrix} ;$$

An the system transfer functions can be easily obtained from the state space equations:

$$\begin{bmatrix} P \\ Q \end{bmatrix} = \begin{bmatrix} G_{11}(s) & G_{12}(s) \\ G_{21}(s) & G_{22}(s) \end{bmatrix} \begin{bmatrix} V_{cq} \\ V_{cd} \end{bmatrix}$$

with:

$$G_{11}(s) = \frac{P}{V_{cq}} \quad G_{12}(s) = \frac{P}{V_{cd}} \quad G_{21}(s) = \frac{Q}{V_{cq}} \quad G_{22}(s) = \frac{Q}{V_{cd}}$$

The instantaneous active and reactive powers generated and absorbed are defined as follows:

$$P_{source} = \frac{3}{2} (V_{sd} i_{sd} + V_{sq} i_{sq}) ; Q_{source} = \frac{3}{2} (V_{sq} i_{sd} - V_{sd} i_{sq}) \quad (11)$$

And the active and reactive powers absorbed by the load are:

$$P_r = \frac{3}{2} (V_{rd} i'_{d} + V_{rq} i'_{q}) ; Q_r = \frac{3}{2} (V_{rq} i'_{d} - V_{rd} i'_{q}) \quad (12)$$

With: $i_{sd} = i_d + i'_d$ and $i_{sq} = i_q + i'_q$

III. CONTROL OF THE UPFC

The combination of both parallel and serial converters with a DC link provides four quadrants control. Fig. 4 shows the block diagram of overall control scheme of the UPFC [11, 12].

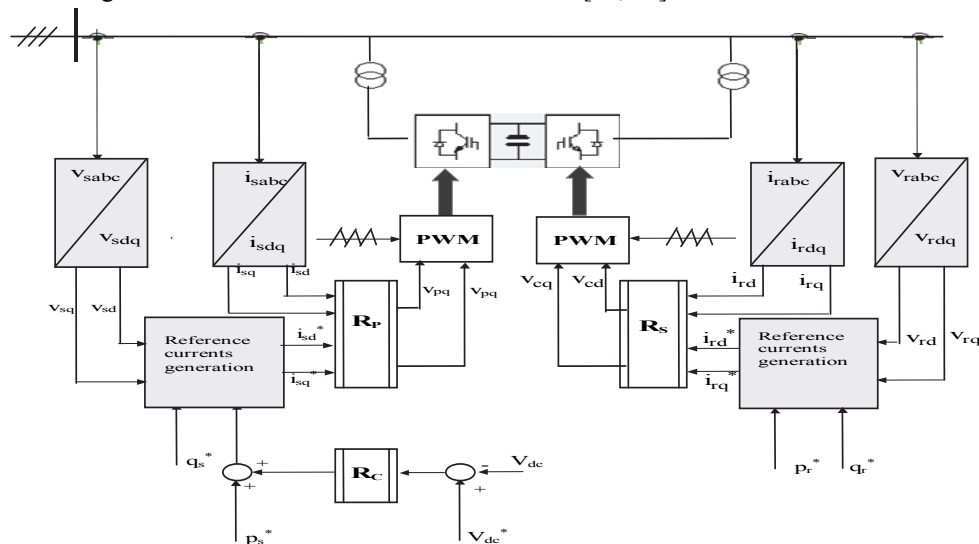

Fig. 4. Full control of the UPFC

IV. POLE-PLACEMENT DECOUPLING CONTROL

From the UPFC model equations derived above it is clear that a coupling exists between the active and reactive power. The decoupling control strategy described in Fig. 5 can be used to achieve independent control of P and Q [10, 11].

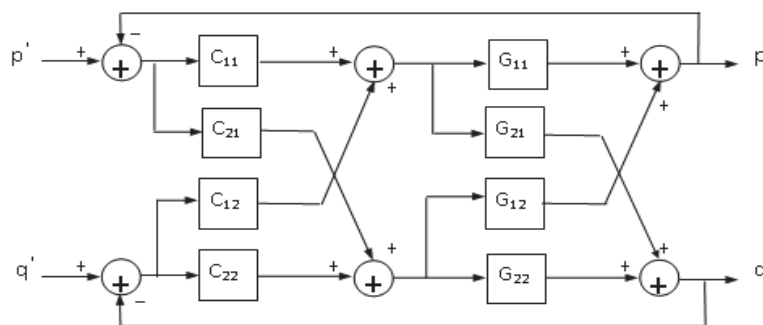

Fig. 5. Pole-placement decoupling controller.

The objective of such design is to select a set of transfer functions C_{ij} for the controller to eliminate interactions (decoupling) and compensate the dynamics of the controlled system. P and Q are given by:

$$P = G_{11}.u_1(t) + G_{12}.u_2(t) \tag{13}$$

$$Q = G_{21}.u_1(t) + G_{22}.u_2(t) \tag{14}$$

The control law is given by $u_1(t)$ and $u_2(t)$:

$$u_1(t) = C_{11}.e_1(t) + C_{12}.e_2(t) \tag{15}$$

$$u_2(t) = C_{21}.e_1(t) + C_{21}.e_2(t) \tag{16}$$

Rearranging gives:

$$P = [G_{11}.C_{11}+G_{12}.C_{21}].e_1(t) + [G_{11}.C_{12}+G_{12}.C_{22}].e_2(t) \tag{17}$$

$$Q = [G_{22}.C_{21}+G_{21}.C_{11}].e_1(t) + [G_{22}.C_{22}+ G_{21}.C_{12}].e_2(t) \tag{18}$$

To decouple or eliminate interactions between variables, the following conditions must be satisfied:

$$G_{11}.C_{12} + G_{12}.C_{22} = 0 \tag{19}$$

$$G_{22}.C_{21} + G_{21}.C_{11} = 0 \tag{20}$$

which lead to:

$$P = [G_{11}.C_{11} + G_{12}.C_{21}].e_1(t) \tag{21}$$

$$Q = [G_{22}.C_{22} + G_{21}.C_{12}].e_2(t) \tag{22}$$

From equations (19) and (20), we find:

$$C_{11} = \frac{C_{12}}{G_{11}G_{21}} ; C_{22} = \frac{C_{21}}{G_{22}G_{12}} \tag{23}$$

The system becomes equivalent to two simple decoupled systems as shown in Fig. 6:

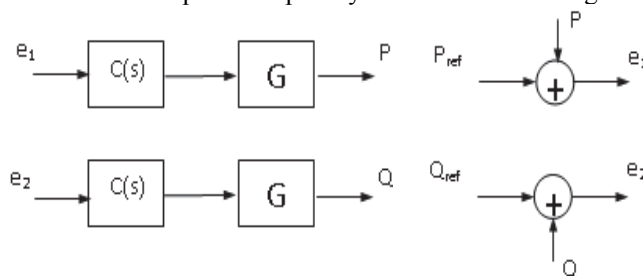

Fig. 6. Equivalent diagram of the decoupling strategy.

The corresponding transfer functions are defined as:

$$q_{11} = \frac{P}{P_{ref}} \text{ and } q_{22} = \frac{Q}{Q_{ref}} \quad (24)$$

The inputs $e_1(t)$ and $e_2(t)$ are given by:

$$e_1(t) = P - P_{ref} \text{ et } e_2(t) = Q - Q_{ref} \quad (25)$$

Substituting equations (24)-(25) into (21)-(22) gives:

$$G_{11}.C_{11} + G_{12}.C_{21} = \frac{q_{11}}{1 - q_{11}} \quad (26)$$

$$G_{22}.C_{22} + G_{21}.C_{12} = \frac{q_{22}}{1 - q_{22}} \quad (27)$$

Similarly:

$$C_{21} = - \frac{G_{21}}{G_{22}} . C_{11} \text{ and } C_{12} = - \frac{G_{12}}{G_{11}} . C_{22} \quad (28)$$

Then equations (26) and (27) become:

$$G_{11}.C_{11} - G_{12} . \frac{G_{21}}{G_{22}} . C_{11} = \frac{q_{11}}{1 - q_{11}} \quad (29)$$

$$G_{22}.C_{22} - G_{21} . \frac{G_{12}}{G_{11}} . C_{22} = \frac{q_{22}}{1 - q_{22}} \quad (30)$$

Solving the system of equations (29) and (30) leads to the controller parameters:

$$C_{11} = \frac{G_{22}}{G_{11}.G_{22} - G_{12}.G_{21}} \frac{q_{11}}{1 - q_{11}} \quad (31)$$

$$C_{22} = \frac{G_{11}}{G_{11}.G_{22} - G_{12}.G_{21}} \frac{q_{22}}{1 - q_{22}} \quad (32)$$

$$C_{21} = - \frac{G_{21}}{G_{11}.G_{22} - G_{12}.G_{21}} \frac{q_{11}}{1 - q_{11}} \quad (33)$$

$$C_{12} = - \frac{G_{12}}{G_{11}.G_{22} - G_{12}.G_{21}} \frac{q_{22}}{1 - q_{22}} \quad (34)$$

The desired transfer function is chosen as a first order:

$$q_{11} = q_{22} = \frac{1}{s + 10}$$

A detailed derivation of the controller parameters is given in [11]. The system is simulated based using this pole-placement decoupling control approach and the results are shown in Figs. 7 and 8. Fig. 7 shows that the response of the system perfectly follows the reference input, reflecting the right choice of controller parameters.

The interaction has been completely removed as the change in the active and reactive power did not result in any transient disturbance at $t = 0.45$ s and $t = 1$ s. Furthermore, a response time of 0.05 s deemed appropriate [11, 12]. Fig. 8 shows the reactive power response to two step changes at $t = 0.5$ s and at $t = 1$ s. Again, the interaction has been completely removed as no disturbance appears in the output.

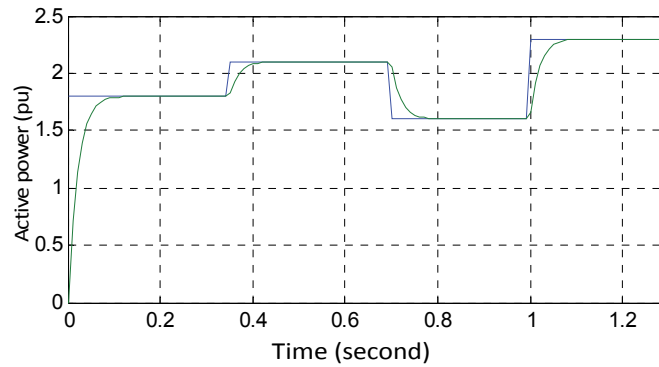

Fig. 7. Active power corrected by the pole placement controller (PP).

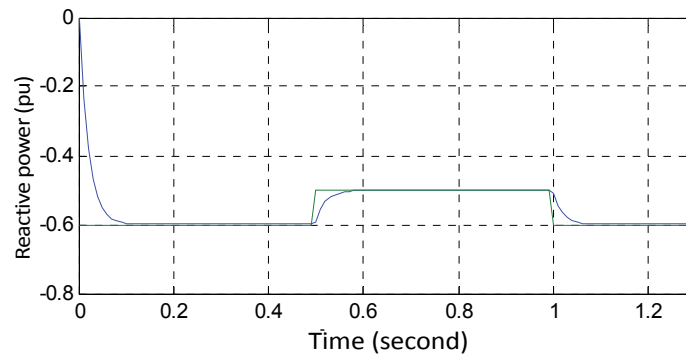

Fig. 8. Reactive power corrected by the pole placement controller (PP)

V. H_∞ CONTROL APPROACH

A. The H_∞ optimal control synthesis

Our system is represented by a transfer matrix $G(s)$ with a number of disturbance elements associated with the environment of the physical system (interference signals, etc.) and modeling errors (reduced order model, idealization actuators, parametric uncertainties, etc.) as shown in Fig. 9 [15].

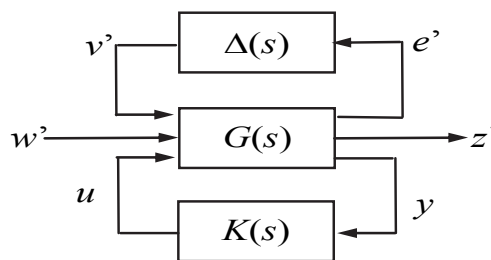

Fig. 9. The canonical robust control problem

The aim of compensation $K(s)$ is to ensure the stability of the closed loop system and a nominal satisfactory behavior. All controller qualities should be preserved as much as possible in the presence of external perturbations (w) and modeling uncertainties $\Delta(s)$, the latter being translated using interference signals v' . At this level, weighting matrices can be introduced on the signals (v') and (w) to perform a frequency and distribution of their structural effects. Assume first that these weights have been addressed in the $P(s)$ model as shown in Fig. 10.

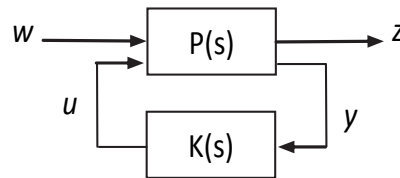

Fig.10. A simplified representation of the control structure

The goal is to find a dynamic compensator such that the stability of the system stability is ensured and that some transfer norm from w to z denoted $F_l(P, K)$ characterizing the performance criteria and/or robustness will be minimized. The problem is then:

$$\min \| F_l (P , K) \| \tag{35}$$

Let $\begin{pmatrix} P_{11} & P_{12} \\ P_{21} & P_{22} \end{pmatrix}$ be a partition of matrix P , the dimensions of each sub-matrix matches with the number of inputs and outputs. Then $F_l(P, K)$ is expressed as:

$$z = F_l(P,K).w = (P_{11} + P_{12}K(I - P_{22}K)^{-1}P_{21}).w \tag{36}$$

The problem formulated in (35) is therefore re-written as:

$$\min \| P_{11} + P_{12}K(I - P_{22}K)^{-1}P_{21} \| \tag{37}$$

The stabilization of the system P by the compensator K is one of the objectives of the compensation. However, P is a multivariable system (multiple inputs and multiple outputs) then, the concept of stability must be specified.

Based on Fig.9, the standard problem is as follows: find the compensator $K(s)$ stabilizes $P(s)$ and minimizes $\|T_{zw}\|_\infty$.

T_{zw} : represents the transfer matrix between w and z .

$P(s)$: is the augmented system that allows us to generate z , corresponding to the objectives of the command and can be represented in state space form by:

$$\begin{bmatrix} \dot{x} \\ y \\ z \end{bmatrix} = \begin{bmatrix} A & B_1 & B_2 \\ C_1 & D_{11} & D_{12} \\ C_2 & D_{21} & D_{22} \end{bmatrix} \begin{bmatrix} x \\ w \\ u \end{bmatrix} \tag{38}$$

Or by its transfer matrix

$$P = \begin{bmatrix} P_{11}(s) & P_{12}(s) \\ P_{21}(s) & P_{22}(s) \end{bmatrix}, \begin{bmatrix} z \\ y \end{bmatrix} = \begin{bmatrix} P_{11}(s) & P_{12}(s) \\ P_{21}(s) & P_{22}(s) \end{bmatrix} \tag{39}$$

To achieve these results, our control problem should be transformed into the standard form according to the principle illustrated in Fig. 11.

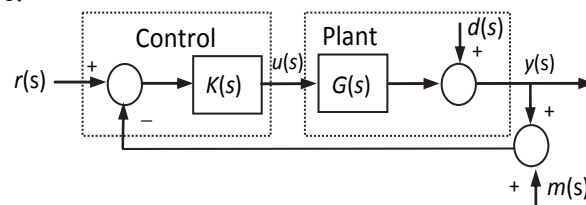

Fig. 11. Classical feedback control system

The objectives of the control are defined as follows:

- disturbance rejection and tracking error:

Minimize $\|W_T(s).T(s)\|_\infty$.

- Noise attenuation $m(s)$, return to maximizing margin multiplicative stability (multiplicative uncertainty output)

\Rightarrow Minimize $\|W_S(s).T(s)\|_\infty$.

- Maximize the margin of stability additive, i.e. limiting the amplitude of the control signal.

\Rightarrow Minimize $\|W_u(s).K(s).S(s)\|_\infty$.

This implies the minimization of:

$$\left\| \begin{array}{l} W_S(s).S(s) \\ W_T(s).T(s) \\ W_u(s).K(s).S(s) \end{array} \right\|_\infty \quad (40)$$

The standard problem can be represented by the equivalent diagram shown in Fig. 12.

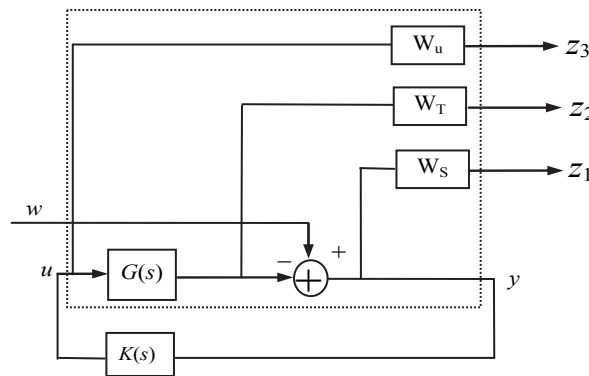

Fig. 12. Closed-loop system with modeling error

Which gives:

$$\begin{bmatrix} z \\ y \end{bmatrix} = \begin{bmatrix} W_S & -W_S.G \\ 0 & W_T.G \\ 0 & W_u \\ I & -G \end{bmatrix} \begin{bmatrix} w \\ u \end{bmatrix} \quad (41)$$

Replacing u by Ky :

$$T_{Zw} = \begin{bmatrix} W_S.S \\ W_T.T \\ W_u.K.S \end{bmatrix} \quad (42)$$

The solution of this problem is obtained using the function H_{inf} or $H_{inf-opt}$ from the Matlab Robust Control Toolbox called Mixed Sensitivity Problem. Other representations of the augmented system to several inputs (w_1, w_2, w_3), and one output z can be addressed.

The synthesis of H_∞ control may be summarized by:

- Translate the objectives $\infty \| \|$.
- Select the weighting functions in terms of their frequency response.
- Set up the matrix $P(s)$ of the equivalent standard problem.
- Solve the optimization problem.
- Test the performance of the closed-loop system.

B. Solution of the standard problem and selection of the weighting functions

Doyle and others [7, 14] have solved this problem by performing standard programs to give the controller status of state space from the system and weighting functions. The assumptions used in the resolution of this problem are:

I) (A, B_2) stabilizable and (A, C_2) detectable .

II) Rank $(D_{12}) = m_2 = \dim(u)$ and rank $(D_{21}) = P_2 = \dim(y)$.

III) $D_{12} = \begin{bmatrix} 0 \\ I \end{bmatrix}, D_{21} = [0, I]$

IV) Rank $\begin{bmatrix} A - j\omega\omega & B_2 \\ C_1 & D_{22} \end{bmatrix} = n + m_2, \forall \omega \in [0, \infty[$

V) Rank $\begin{bmatrix} A - j\omega\omega & B_1 \\ C_2 & D_{21} \end{bmatrix} = n + P_2, \forall \omega \in [0, \infty[$

- Assumption (I) is necessary and sufficient for the existence of a solution.
- Assumptions (II), (IV) and (V) ensure that the problem is well posed, in other words, the compensator is appropriate.
- Assumptions (IV) and (V) indicate that $P_{12}(s)$ and $P_{21}(s)$ have no zeroes on the imaginary axis, they can be avoided [7].
- Assumption (III) simplifies the solution.
- If assumption (II) is satisfied, it can be used to check system (III). This operation is performed by the H_{inf} program Matlab.
- The only problem that may arise is that of the validation of assumption (II).

C. Validation of the assumption (II)

If, by executing the instruction H_{inf} (Robust Control Toolbox of Matlab), the error signal «matrix D_{12} is not in full column rank», this means that the hypothesis (II) is not verified, and therefore the transfer functions $P_{12}(s)$ and $P_{21}(s)$ have zeros at infinity [9].

In order to ensure the closed loop stability and simultaneously achieve the desired control performance under process variations or in the presence of other disturbances weighting functions dependent of the frequency in the process are introduced as shown in Fig.13.

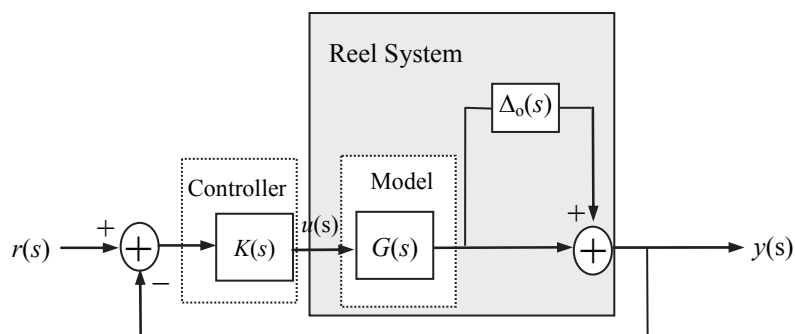

Fig. 13. Control system with modeling error

The controller optimization is defined by the following equation:

$$\|W_T(s).T(s)\|_{\infty} < \gamma \quad \forall \omega \in [0, \infty[\tag{43}$$

These weighting functions define the frequency characteristics of the signals of the system as well as their amplitudes.

Putting $|W_T(j\omega)| \geq 1$ for a certain frequency range, the gain reduction of the complementary sensitivity function $T(j\omega)$ can be achieved beyond this range.

It is now assumed that also seeks a good performance (characterized by $S(j\omega)$) residing in the disturbance rejection. This performance can be achieved by finding the controller $K(s)$ by solving the following equation:

$$\|W_S(j\omega).S(j\omega)\|_{\infty} \quad \forall \omega \in [0, \infty[\quad (44)$$

This equation is equivalent to:

$$\|W_S(j\omega).S(j\omega)\|_{\infty} < \gamma_{\text{const}} \quad \forall \omega \in [0, \infty[\quad (45)$$

γ_{const} is an arbitrary constant which is not necessarily equal to γ (44).

Performance objectives and the robust stability can be simultaneously achieved by seeking a controller $K(s)$ satisfying the following inequality:

$$\left\| \frac{W_S(j\omega).S(j\omega)}{W_T(j\omega).T(j\omega)} \right\| < \gamma \quad (46)$$

The choice of the weighting functions is as follows: Depending on the required performance, $W_S(j\omega)$ is large at low frequency and smaller at high frequency, representing a low pass filter.

In our case, it is a diagonal matrix $W_S(j\omega) = w_S.I$, where w_S represents the weighting function selected such that: $|S(j\omega)| < \frac{1}{|w_S(j\omega)|}$ or $\overline{\sigma}(S(j\omega)) < \frac{1}{|W_S(j\omega)|}$ for multivariable systems.

Generally, the uncertainties and dynamics are neglected high frequencies, $W_T(j\omega)$ must be represented by a high pass filter to ensure robustness for high frequencies ($\omega > \omega_0$) and acceptable performance for low frequencies ($\omega < \omega_0$).

Our choice of weighting coefficients is completely connected to the parameter γ as explained above (following the objectives set such that the bandwidth in this case equal 70rd/s [6]), after trial and error, a value of $\gamma = 1.92$ was selected and the transfers functions of the weighting coefficients are:

$$W_S = \frac{10s+1}{10(1/70s+1)} \quad \text{and} \quad W_T = \frac{278}{0.01s+0.01}$$

These weighting coefficients W_S and W_T define the controller $K(s)$. The responses of the active and reactive powers are illustrated in Figs.14 and 15. From these results, it can be noted that the powers track their respective references perfectly, reflecting the right choice of parameters of our $K(s)$. In addition, through the weights W_T and W_S defined, the interaction between the powers is completely eliminated and hence the controller was able to decouple the system and ensure good performance and achieve the control objective [15, 17].

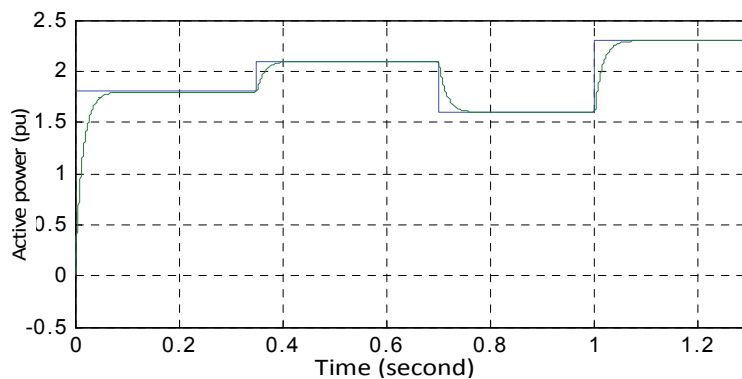

Fig. 14. Response of the active power with $K(s)$ control

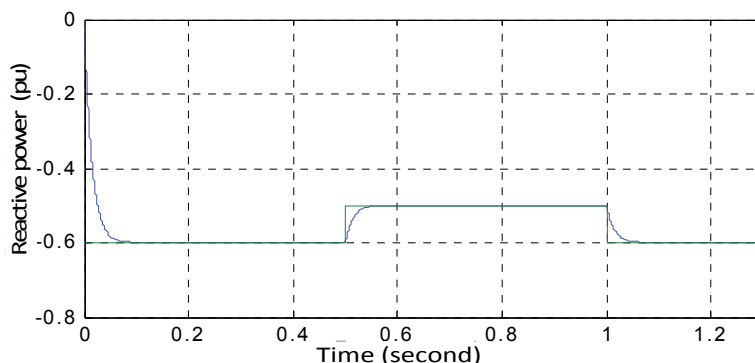

Fig. 15. Reactive power corrected by the $K(s)$ H_∞

VI. ROBUSTNESS AND COMPARATIVE STUDY BETWEEN POLE-PLACEMENT AND H_∞ TECHNIQUES

After applying these two control techniques to the UPFC system and following the various simulation results obtained, it can be concluded that the H_∞ control produced better transient and steady-state response characteristics. In addition, a decoupling between the active and reactive powers has been achieved with improved stability and robustness. The pole-placement control is insufficient despite its contribution to the decoupling of the system because its time response remains greater than that of control H_∞ as shown in Figs.16 and 17.

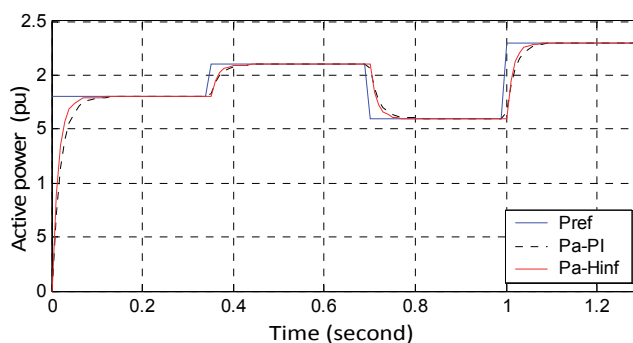

Fig. 16. Actives power: PP + H_∞

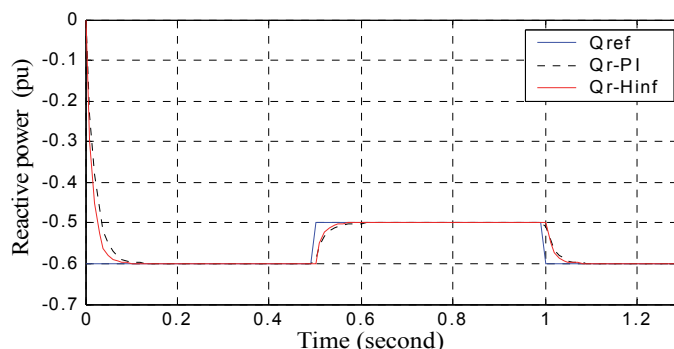

Fig. 17. Reactive power with: PP + H_∞

A. Increase of the line inductance by 20%

The change in the transmission line parameter, simulated as a 20% increase in the inductance, caused a significant deterioration in the performance of the pole placement (PP) controller. The corresponding active and reactive power are shown in Figs.18 and 19. On the other hand, for H_∞ control the response characteristics have not been affected which confirms the robustness of the controller.

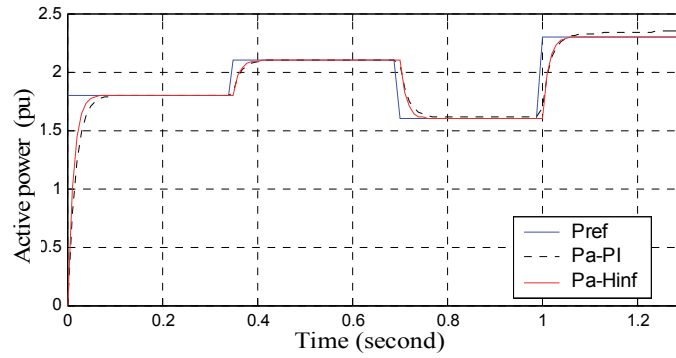

Fig. 18. Active power observed with PP + H^∞ due to the 20% inductance of the line increase

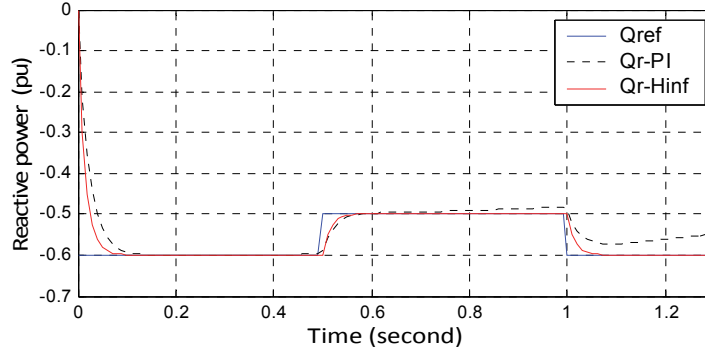

Fig. 19. Reactive power observed with PP + H^∞ due to the 20% inductance of the line increase

B. Reduction of the line inductance by 20%

In this case, similarly to the previous simulation scenario, the PP controller was unable to maintain the desired performance and robustness requirements. It is therefore concluded that the H^∞ control is best suited to our application as illustrated by Figs.20 and 21.

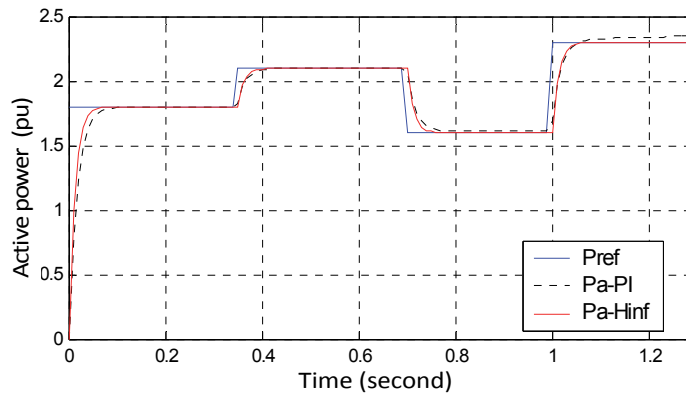

Fig. 20. Active power observed with PP + H^∞ due to the 20% inductance of the line decrease

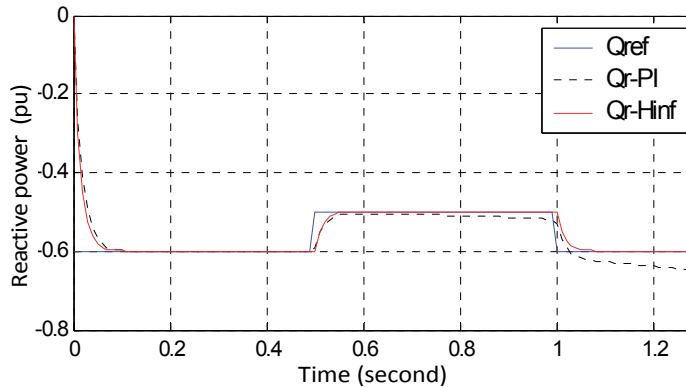

Fig. 21. Reactive power observed with PP + H^∞ due to the 20% inductance of the line decrease

VII. CONCLUSION

In this work, we focused to show the control of the UPFC by pole placement and the H_∞ control. Despite its ability to decouple, the control by pole placement is unable to follow the reference in case of decrease or increase the inductance of the line, on the contrary the control H_∞ could ensure the desired performance, this implies that the control H_∞ is robust and also implies a good synthesis of coefficients and weighting functions thereof.

REFERENCES

- [1] Jiang, Y., "Active and Reactive Power Control for Transmission Systems with Voltage Source Converters". PhD Thesis, Department of Electric Power Engineering. Stockholm, Sweden, 1997. E. S.
- [2] Sudhakara Babu, C., "Control of a Unified Power Flow Controller (UPFC), a simulation study using matlab/simulink." Department of Electrical Engineering Regional, Engineering College. Calcut-673601, Kerala 2002.
- [3] Zames, G., "Feedback and optimal sensitivity: model reference transformations, multiplicative seminorms and approximative inverses." IEEE Trans. Aut. Contr. 1981. 585-601.
- [4] Oustaloupi, A., "La robustesse Analyse et Synthèse de Commandes Robustes." *Edition. Hermes, Paris*, 1994.
- [5] Farane, D.M., Glover, K., "A loopshaping design procedure using H_∞ synthesis." IEEE Trans. Aut. Contr. June 1992.
- [6] Doyle, J.C., Glover, K., Khronekar, P., Francis, B.A., "State space solution to standard H_2 and H_∞ Control problems." IEEE Trans. Aut. Cont. Août 1989.
- [7] Doyle, J., "Robust and optimal control." Proceedings of 35th C.D.C. Kobe, Japan, décembre 1996.
- [8] Sambalancat, C., "Commande robuste multivariable, application à l'hélicoptère." Thèse de doctorat d'état, ENSAT, Toulouse 1991.
- [9] Zebirate, S., "Réglage multivariable d'un UPFC pour la compensation des puissances active et réactive." Magister thesis, Université M. Boudiaf, UST Oran, Electrical Engineering department, Mai 2002.
- [10] Allaoui, T., Denaï, M. A., Bouhamida, M., Belfedal, C., "Robust Control of Unified Power Flow Controller (UPFC)." Journal of Electrical & Electronics Engineering, Vol. 7, N. 1, 2007, pp. 331-343.
- [11] Allaoui, T., Denai, M. A., "Robust Internal Model Control of Unified Power Flow Compensation." Conférence sur le Génie Electrique CGE'01, EMP, 25-26 décembre 2001.
- [12] Balas, G.J., Doyle, J.C., Glover, K., Packard, A., Smith, R., "Mu Analysis and Synthesis Toolbox." The Math Works Inc. 1993.
- [13] Mahdad, B., Bouktir, T and Srari, K., "The impact of Unified Power Flow Controller in Power flow regulation." JEE journal, Vol. 6(1), 2006.
- [14] Bouhamida, M., Denai, M.A., "Multivariable Robust Power System Stabilizer Design based on H_∞ ." Third International Power Electronics and Motion Control Conference IPEMC 2000, Tsinghua University, Beijing, China, August 15-18, 2000.
- [15] M. Ahmed, Kassem, M. and Youssef, A.M.: Robust H_∞ Control design Dynamic Performance Analysis of isolated generation unit. JEE Journal, Vol. 8(6), 2008.