

PAPER • OPEN ACCESS

## Effect of Repulsive Magnetic Poles on the Natural Frequency and the Bandwidth of a Vibration Energy Harvester

To cite this article: Thein Chung Ket *et al* 2018 *J. Phys.: Conf. Ser.* **1123** 012019

View the [article online](#) for updates and enhancements.



**IOP | ebooks™**

Bringing you innovative digital publishing with leading voices to create your essential collection of books in STEM research.

Start exploring the collection - download the first chapter of every title for free.

# Effect of Repulsive Magnetic Poles on the Natural Frequency and the Bandwidth of a Vibration Energy Harvester

Thein Chung Ket<sup>\*1</sup>, Faruq Muhammad Foong<sup>1</sup>, Ooi Beng Lee<sup>2</sup>

<sup>1</sup> School of Engineering and Physical Sciences, Heriot-Watt University, No. 1, Jalan Venna P5/2, Precinct 5, 62200 Malaysia.

<sup>2</sup> Intel PSG, PG 14, Plot 6, Bayan Lepas Technoplex, Medan Bayan Lepas, 11900 Penang, Malaysia.

\*c.thein@hw.ac.uk

**Abstract.** Vibration energy harvesting has emerged as a promising source of sustainable power for wireless sensor networks. This paper describes the effect of alike magnetic pole repulsion on the natural frequency and operational bandwidth of a cantilever-based vibration energy harvester. Experimental result shows that the magnetic repulsive force produced by two horizontally oriented magnets was able to reduce the natural frequency of a cantilever by up to 35% as compared to a typical cantilever beam oscillated under normal conditions. Changing the orientation of one of the magnets to a vertical position reduces the magnetic repulsive force, resulting in a higher natural frequency, transmissibility and maximum amplitude than the horizontal orientation. The magnetic repulsive force effect also resulted in a significant increase in the operational bandwidth of the cantilever beam, recording different natural frequencies for different base acceleration magnitudes. For every 0.1 *g* increase in base acceleration value, the two horizontally oriented magnet configurations recorded an increase of 0.9 Hz in natural frequency, whereas an average increase of 0.6 Hz was recorded for the latter configuration.

## 1. Introduction

Wireless sensor networks (WSN) play an important role in realizing the concept of the Internet of Things (IoT) under the vision of Industry 4.0. Generally, the concept of IoT requires cyber-physical systems embedded with a number of sensors to monitor and communicate with people and each other via WSNs. In some scenarios, the WSNs are required to be installed in places where a direct power source is inaccessible. These WSNs are usually powered by a conventional battery. However, this method can prove to be inconvenient and inefficient, as batteries have a short life span and require constant replacement [1–3]. Hence, this introduces the issue of finding a sustainable energy source for WSNs.

Vibration energy harvesting emerges as one of the most promising methods to provide a sustainable source of power for WSNs, due to the abundance of vibrations from ambient surroundings and its high power density [4]. Over the past decades, various studies have been conducted in an attempt to increase the power output or the frequency bandwidth of a vibration energy harvester, while consuming a minimal volume of space [5-7]. Some of the main issues with miniaturization of a cantilever-based vibration energy harvester include achieving a low natural frequency and a large operational bandwidth. Ambient vibrations from surroundings tend to be relatively low (< 100 Hz), spreading over a wide range of frequencies [8]. Due to the size constraint in miniaturization, small cantilever beams are used resulting in a high natural frequency. Masses can be added onto the beam to reduce its natural frequency. However, a large mass is usually required to reduce the frequency to a desired value, consuming more space. Maximum power can be achieved by a vibration energy harvester when its natural frequency matches the



ambient frequency [9]. If the ambient frequency slightly deviates from the natural frequency of the harvester, a drastic drop in power would occur. Therefore, methods to improve the operational bandwidth of a vibration energy harvester are desirable.

In this work, the repulsive effect of two similar magnetic poles on the natural frequency and bandwidth of a cantilever beam was explored. The design consisted of two permanent magnets, in which one was fixed onto the free-end of a clamp-free cantilever beam and the other was clamped onto a vibrating surface, as shown in Figure 1. Both magnets were aligned with each other, ensuring that the outward facing magnetic pole of both magnets were the same. This induced a repulsive force on the cantilever beam, whether the beam was static or oscillating, resulting in a nonlinear vibration. The effects of the magnetic repulsive force on the characteristic of the vibrating beam were studied and compared with a regular beam vibration.

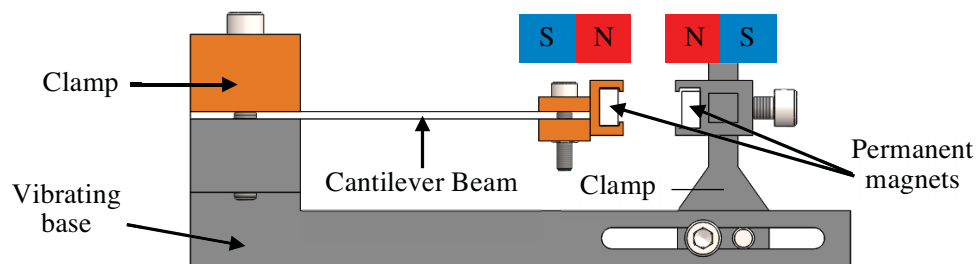

**Figure 1.** Design of a cantilever beam to make the magnet and the coil vibrate in the opposite direction.

## 2. Methodology

In this work, an experiment was conducted to determine the effect of alike magnetic poles on the bandwidth and natural frequency of a cantilever beam. The experimental setup is shown in Figure 2. A full explanation on the experimental setup can be found in [10]. The setup in Figure 2(a) will be referred to Case 1 and the setup in Figure 2 (b) and (c) represents Cases 2 and 3, respectively.

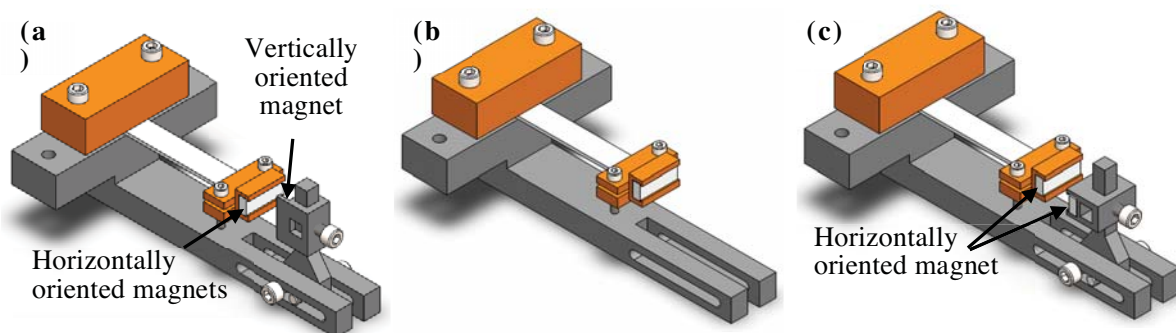

**Figure 2.** Experiment setup for the cantilever beam whereas (a) Case 1 – end magnet is oriented vertically, (b) Case 2 – end magnet is removed, and (c) Case 3 – end magnet is oriented horizontally.

The experiment for Case 1 was conducted first. The cantilever beam material used in this experiment was polyvinyl chloride (PVC) sheet with a Young's modulus of 3.3 GPa and a density of 1450 kgm<sup>-3</sup>. A small neodymium magnet measuring 25×10×5 mm was horizontally attached to the free-end of the beam, with the north magnetic pole facing outwards, as seen in Figure 2(a). A second magnet was vertically oriented onto the shaker using a clamp and aligned with the other magnet. The north magnetic pole of this magnet was set facing the other magnet to induce a repulsive force effect. A distance of 17.4 mm between the two magnets was maintained throughout the experiment. Two laser displacement sensors were used to capture the response at the magnet on the free-end tip of the beam and the vibrating base, as seen in Figure 3. The recorded responses were amplified before being transferred to a computer using a data acquisition device.

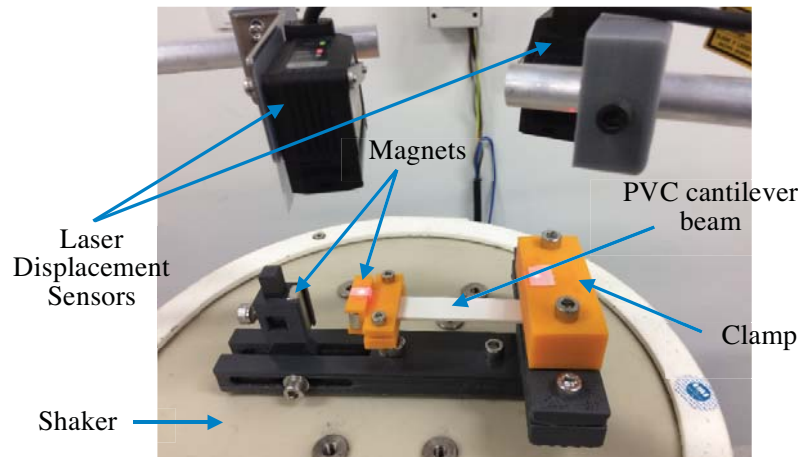

**Figure 3.** Experimental setup for Case 3.

The shaker was initially oscillated at a very low acceleration magnitude of  $0.04\text{ g}$  ( $1\text{ g} = 9.81\text{ ms}^{-2}$ ), with a frequency sweep rate of 0.05 octaves per minute. The experiment was then repeated using a base acceleration magnitude of  $0.2\text{ g}$ ,  $0.3\text{ g}$  and  $0.4\text{ g}$  respectively. The results for each acceleration magnitude were recorded. The clamped magnet was then rotated  $90^\circ$  into a horizontal position and realigned with the other magnet, as shown in Figure 2(c). The position of the magnetic poles and the distance between the two magnets remained unchanged. Similarly, measurements at an acceleration magnitude of  $0.2\text{ g}$ ,  $0.3\text{ g}$  and  $0.4\text{ g}$  were conducted and recorded for this configuration. Afterwards, the clamped magnet was removed from the shaker, as seen in Figure 2(b), eliminating the repulsive force effect. The readings for an acceleration magnitude of  $0.04\text{ g}$  were taken. A mass was then added on top of the magnet at the free-end of the beam to reduce the beam's natural frequency, and the readings for the same acceleration magnitude were re-taken. All recorded results were then compared and analysed. Figure 4 describes the process flow on the entire experiment.

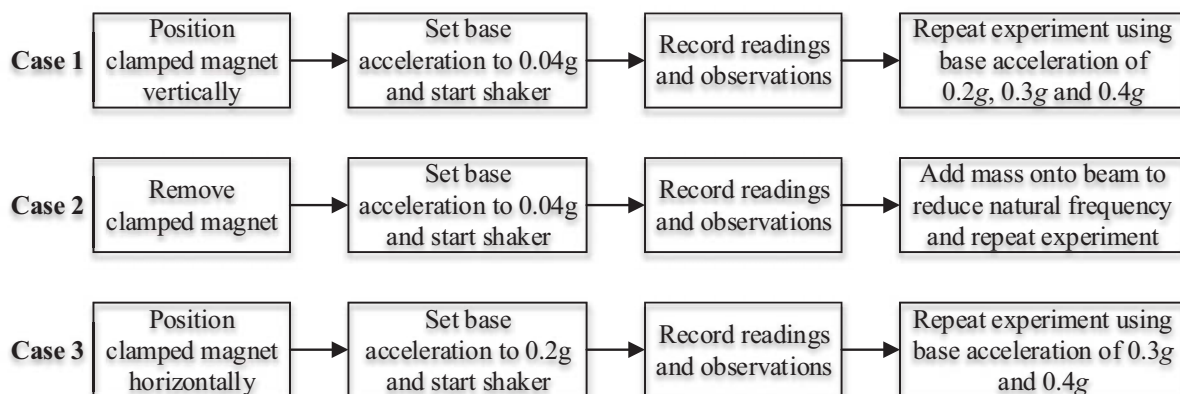

**Figure 4.** Experiment process flow for Cases 1, 2 and 3.

### 3. Results and Discussion

In this section, the results obtained for Cases 1, 2 and 3 were analysed. Figure 5 describes the amplitude and the transmissibility response curves for Cases 1 and 2 at the base acceleration magnitude of  $0.04\text{ g}$ .

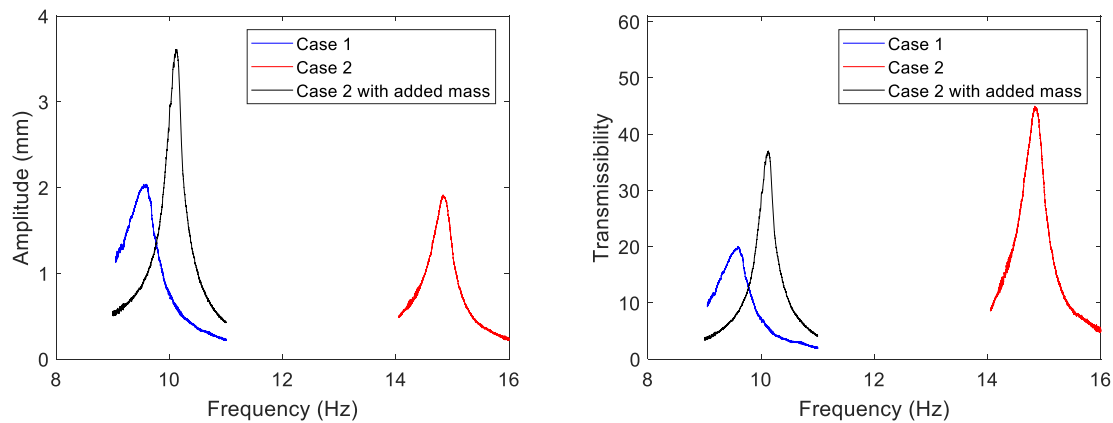

**Figure 5.** Amplitude vs frequency curve for Cases 1 and 2 (Left) and Transmissibility vs frequency curve for Cases 1 and 2 (Right) under a base acceleration magnitude of 0.04g.

In terms of natural frequency, Cases 1 and 2 recorded a natural frequency of 9.6 Hz and 14.8 Hz, corresponding to a 35% decrease in natural frequency for Case 1. This shows that one of the effects of the magnetic repulsive force is the significant reduction in natural frequency for the same beam configuration. Although a similar maximum amplitude was recorded for Cases 1 and 2, the transmissibility of Case 2 was more than twice that of Case 1. This is due to the magnetic repulsive effect of the alike pole magnets hindering the vibration on the beam in Case 1. Nevertheless, the reason that Case 1 was able to achieve the same amplitude as Case 2 was because the base excitation amplitude was higher at lower frequencies. An additional mass of 31.29 grams was added to Case 2 to reduce the natural frequency and to match Case 1. In this investigation, it was noted that the maximum amplitude increased significantly. Hence, under a tight volume constraint, Case 1 would be a more desirable approach for frequency reduction. In addition, Case 1 also recorded a 37% higher bandwidth than Case 2, with the bandwidth of Cases 1 and 2 being 0.48 Hz and 0.35 Hz, respectively.

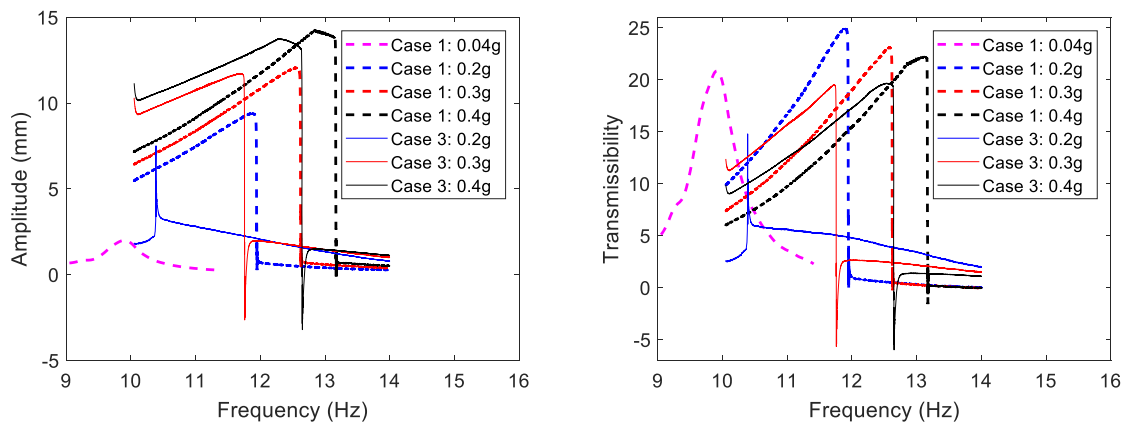

**Figure 6.** Amplitude vs frequency curve for Case 1 and 3 (Left) and Transmissibility vs frequency curve for Case 1 and 3 (Right) under several different magnitudes of base acceleration.

Figure 6 describes the amplitude response and transmissibility response curves for Cases 1 and 3 at different base acceleration magnitudes. At higher base acceleration magnitudes, a drastic drop in amplitude was observed after the vibrating beam reached resonance. The same trend was also recorded by Stanson et al. [11]. This trend is different than the trend recorded at a base acceleration of 0.04 g (Figure 5). The difference can be related to the increase in vibrational amplitude of the beam at high acceleration magnitudes, allowing the beam to overcome the magnetic repulsive forces, while inducing a nonlinear effect on the beam. The drastic amplitude drop was more prominent for Case 3, due to the stronger

magnetic repulsive force. It is observed that for Case 3, an oddly shaped curve was recorded for a base acceleration of 0.2 *g*. It is believed that this may be due to the fact that the vibrating beam was just barely able to overcome the repulsive force of the magnets for only a single instant. However, the same odd curve was not recorded for Case 1 for the same acceleration magnitude. This is because the configuration of a vertical magnet decreased the magnetic field strength, leading to a decrease in magnetic repulsive force. The results for Cases 1 and 3 at an acceleration magnitude of 0.4 *g* are slightly flatter at the tip of the curve compared to other acceleration magnitude readings. This is an experimental miscalculation, in which the vibrational amplitude of the beam was too high, causing the beam to hit the vibrating base. The true natural frequency at this measurement was expected to be slightly lower than the recorded result.

In addition, the damping ratio also increased by approximately 18% from Case 1 to 3. This means that Case 3 results in a higher damping ratio compared to Case 1. For 0.2 *g*, the damping ratio increased significantly due to the effect of magnet in Case 3 in resisting the movement of the beam vibration. Hence, it recorded a maximum amplitude at the natural frequency. Once, the vibrating frequency differ from the natural frequency, the beam amplitude experienced a sudden drop. Table 1 shows that the damping ratio for different acceleration levels.

Table 1:

Acceleration level ( <i>g</i> )	Case 1	Case 3	% difference
0.04	-	0.021547	-
0.2	0.000130	0.034779	26573.9
0.3	0.047669	0.038813	18.6
0.4	0.052490	0.042838	18.4

A notable difference between Cases 1 and 3 is in the maximum amplitude, transmissibility and the resonance frequency. Case 3 recorded a lower maximum amplitude and natural frequency than Case 1 for all base acceleration values, owing to the stronger magnetic repulsive force effect in Case 3. The effects of acceleration magnitudes on the natural frequency of a typical cantilever oscillator are often ignored. Naturally, increasing the base acceleration magnitude would result in an increase in mechanical damping of the system, hence reducing the damped natural frequency of the beam. However, the changes induced were very small and insignificant. In contrast, Figure 6 demonstrated that for Cases 1 and 3, a significant effect on the natural frequency can be observed at different base acceleration magnitudes. For every 0.1 *g* increase in base acceleration magnitude, an average increase of 0.6 Hz in natural frequency was recorded for Case 1 and an increase of 0.9 Hz was observed for Case 3. This suggests that the bandwidth for Cases 1 and 3 were significantly increased in relation to a range of base acceleration magnitudes. It can also be inferred that a stronger magnetic repulsive force effect may result in a larger bandwidth.

#### 4. Conclusions

This paper presented an investigation on the effect of magnetic repulsive force on the natural frequency and bandwidth of a cantilever beam for vibration energy harvesting applications. It was found that the repulsive effect of two alike magnetic poles (Case 1) caused the natural frequency of the beam to significantly decrease when compared to the same beam under normal conditions (Case 2). The transmissibility recorded for Case 1 was lower than Case 2. However, it is believed that the configuration in Case 1 would be more favourable for a small volume design.

Rotating one of the magnets into a horizontal position (Case 3) resulted in a lower maximum amplitude, transmissibility and natural frequency compared to Case 1, due to a stronger repulsive force. The bandwidth of Case 1 and 3 was observed to significantly increase under different base acceleration magnitudes, noting an average of a 0.6 Hz increase in natural frequency for Case 1 and a 0.9 Hz increase for Case 3 when the base acceleration value was incrementally increased by 0.1 *g*. Hence, this also suggests that an increase in magnetic repulsive force effect may result in a larger operational bandwidth.

Further work on this topic would focus on the effect of different magnetic repulsive strengths on the natural frequency and the bandwidth of a cantilever beam. Incidentally, this can easily be achieved by varying the distance between the two permanent magnets, or by changing the type and size of the magnets. A theoretical approach would also be explored in order to optimize the design for maximum power output.

## References

- [1] Xenofon F, Dusan V, Alessio D M, Nicola D, Jan M, 2012 Energy-Harvesting Wireless Sensor Networks *9th European Conf. on Wireless Sensor Networks, EWSN 2012: Poster and Demo Proc.* (Italy: Trento) 84–5.
- [2] Ooi B L, Gilbert J M, Thein C K, Abdul Rashid A, A 2015 Analytical Modeling for Switched Damping Electromagnetic Energy Harvester *Applied Electromagnetic International Conf.* (Thailand: Krabi) 1–12.
- [3] Ma Y, Ji Q, Chen S, Song G, 2017 An experimental study of ultra-low power wireless sensor-based autonomous energy harvesting system *J. Renew. Sustain. Energy* **9** 1–16.
- [4] Thein C K, Thein, Ooi B L, Liu J S, Gilbert J M, 2016 Modelling and optimization of a bimorph piezoelectric cantilever beam in an energy harvesting application *J. Eng. Sci. Tech.* **11(2)** 212–27.
- [5] Zoua H X, Zhang W M, Li W B, Wei K X, Hua K M, Peng Z K, Meng G, 2018 Magnetically coupled flexensional transducer for wideband vibration energy harvesting: Design, modeling and experiments *J. Sound Vib.* **416** 55–79.
- [6] Tai W C, Zuo L, 2017 On optimization of energy harvesting from base-excited vibration *J. Sound Vib.* **411** 47–59.
- [7] Thein C K, Liu J S, 2017 Numerical modeling of shape and topology optimisation of a piezoelectric cantilever beam in an energy-harvesting sensor *Eng. with Comput.* **33** 137–48.
- [8] Li H, Tian C, Deng Z D, 2015 Energy harvesting from low frequency applications using piezoelectric materials *Appl. Phys. Rev.* **1** 1–21.
- [9] Ooi B L, Gilbert J M, 2015 Design of wideband vibration-based electromagnetic generator by means of dual-resonator *Sens. Actuat A: Physical* **213** 9–18.
- [10] Foong F M, Thein C K, Ooi B L, Abdul Rashid A, A 2017 A Low-Cost Vibration Analyser for Analogue Electromagnetic Shaker *Proc. IEEE ICSIPA* (Sarawak: Malaysia) 12–4.
- [11] Stanton S C, McGehee C C, Mann B P, 2010 Nonlinear dynamics for broadband energy harvesting: investigation of a bistable piezoelectric inertial generator *Physica D: Nonlinear Phenom* **239(10)** 640–53.

## Acknowledgments

The authors would like to thank the Fundamental Research Grant Scheme (FRGS) from Ministry of Higher Education (MOHE) Malaysia, Grant No: FRGS/1/2016/TK03/HWUM/03/1, for funding this research.