

# Innovation of a Humanoid Robotic Wrist

Haider A. F. Almurib<sup>1</sup>, Haidar Fadhil Al-Qrimli<sup>1</sup>, Nandha Kumar<sup>1</sup> Fadhil Abbas Mahdi<sup>2</sup>

<sup>1</sup>Department of Electrical & Electronic Engineering, The University of Nottingham Malaysia Campus

Jalan Broga, 43500 Semenyih, Malaysia

<sup>2</sup>Department of Electrical Engineering, University of Baghdad, Baghdad, Iraq

(Tel: +60-3-8924-8613; [halqrimli@yahoo.com](mailto:halqrimli@yahoo.com))

**Abstract**— Combining human and robot into a particular structure put forward extraordinary opportunities for generating a new generation of knowledge. The idea of producing a mechanism that can strictly collaborate with humans. This advance spot presents innovative challenges for engineers and designers. On the contrary, to industrial robotics meant for which mechanical stiffness and rigidity, accuracy and high velocities are most important requirements the solution feature. Here is a movement freedom that matches to that of the human people, avoidance of risk to users and a lightweight mechanism. In order to achieve these requirements the robot should have a human like appearance, same workspace, dexterity and the kinematics should be common to the user. This article presents a new design of a robotic arm wrist for the next development of humanoid robots, and it is a part of an on-going project that involves a 7-DOF robotic arm powered by electrical actuators and has a new hybrid structure. The aim of this research is to achieve a human like wrist that has the same number of degree of freedom and improves the workspace. The new mechanism of the wrist is discussed in details in the article.

**Keywords**— Humanlike, Parallel Manipulator, Wrist, Robotic Arm.

## I. INTRODUCTION

Parallel geometry is closed-chain geometry, which has multiple kinematic chains connecting the base to the end-effector. The primary improvement is seen in the good structural stiffness, with respect to open-chain manipulators. This structure is suitable for the execution of manipulation tasks requiring large values of force along the vertical direction [1-2]. Huapeng 2008, [3] build up a parallel robot with 10-DOF that which is capable of holding all necessary machining tools and welding end-effectors. Parallel manipulators have additional links and joints between its end effector (the moving part) to its base. It proves to be stiffer and more precise than serial manipulators, except it gives a smaller workspace of the end effector activity [6]. There are a lot of literatures that deal with parallel configuration. In 2006 [4] proposed a two leg parallel manipulator, and they make a kinematics analysis of the parallel mechanism and illustrate the workspace of the

proposed manipulator the application of this project is for surgery applications. There is a demand in studying the kinematics and developing parallel manipulators such as, Peter [5] investigated the kinematics and stiffness of an isotropic three-legged manipulator having six degrees of freedom. The rotary motors on the base revolve around the tool with the extensible legs as drive shafts. In 2010 [7] formulated the kinematic equations and the forward displacement analysis of 2-DOF spherical parallel manipulator that can be used as a hip joint of the humanoid robot. Figure 1 shows the CAD model of the 2-DOF spherical parallel manipulator.

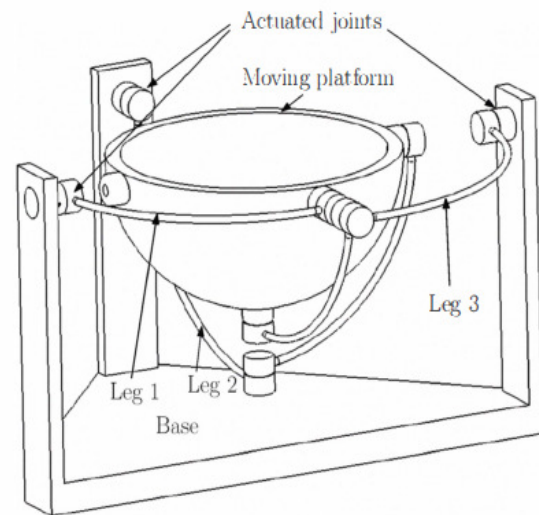

Figure 1. CAD model of the 2-DOF spherical parallel manipulator. (Xianwen, 2010)

Three-degree-of-freedom parallel manipulators are used in a lot of applications that need orienting a body in space and allowing three independent rotations of the movable platform about a fixed location. [9] Presents a structural synthesis of a parallel wrist with three degrees of freedom. Besides, the actuators are mounted directly on the base, to reduce the weight of the moving parts. Minoru and Yuichi [8] built a trial prototype that have a parallel conflagration with 3 degree of freedom. They showed the mechanical design and displacement analysis.

The trial model has the necessary flexibility for pick and place and polishing applications. Patrick in 2002 [10] proposed a new spherical-type 3-DOF parallel mechanism. Many researchers are concerned about analysis of kinematics in parallel actuated mechanism that has 3-DOF, which can be used as a wrist in the robotic device [12, 13 and 14]. They have been designed and fabricate a prototype for educational reasons [11]. A novel parallel mechanism with 3-DOF named Argos was presented [15] the end effector is linked to its base by three identical kinematic chains. Prototype has been done.

The forward and inverse kinematic was solved in a closed form, both having eight solutions. Commonly, industrial manipulators typically contain six DOF that was, firstly, proposed by Stewart in 1965 as an aircraft simulator platform [16]. As given away in the previous literatures that the parallel manipulators with less than 6-DOF are able to meet exact tasks, and have the improvement of reducing complication, design redundancy and price. Wrist mechanisms can be classified in more than a few different ways. They can be classified by their degree of freedom, nature of motion (such as spherical, non spherical mechanisms), or other geometric considerations. Commonly, the joint axes of a wrist mechanism do not essentially have to cross at an ordinary point. Practically, a high-quality wrist design should have these characteristics: 1. Three degree of freedom, 2. Spherical motion, 3. Large workspace, 4. Remote drive capability, 5. Compact size, light weight, and low inertia, 6. High accuracy. 7. High mechanical stiffness, 8. Low mechanized cost. The improvement of wrist mechanisms can be dated back to the early nine tenth century [17-18]. It is linked specially to the requirements in handling equipments, and for many other hazardous tasks. To achieve the necessary characteristics mechanical transmission mechanisms such as epicyclical gears trains, push-rod linkages, and tendon drives are frequently in use, but no one is using a parallel configuration by using electric linear actuators. As given away researches are paying attention on designing configuration, number of degrees of freedom, and grasping strategies. Conversely, the inertial actions or movements caused by acceleration of a humanoid robot wrist and the other motors effect and disturb the grasp robustness of the grasper (fingers) of the humanoid hand significantly. To facilitate an acquire acceleration apply to robot wrist and efficiently counteract disturbance to make sure the stable and accurate grasp of the robot end effector, a three degree of freedom robotic wrist is required.

## II. WRIST MECHANICAL DESIGN

An innovative category of structural configuration of a humanlike wrist is developed in this project, and this wrist consists of a parallel manipulator which represents human wrist. Determination of the optimized locations of every part of the joints, distance end to end of the frames and connections are all completed, additional analysis were carried out by developing a 3D wrist model by using a computer aided engineering software. All the potential movements of the model parts were studied to keep away from interference among the wrist parts specially the actuators base.

The CAD design of the wrist is shown in Figure 2. In the design of the wrist, the actuation is by using linear actuators. The wrist has 3-DOF which is the same to the human wrist. It contains three linear actuators, three revolute joints in the fixed base side, and three spherical joints in the movable base side. The fixed and the movable base will be made of aluminum alloy materials. A square cross section with 5 mm depth and 20 mm X 20 mm in the back side was done to attach the forearm manipulator to the wrist base and ensure there will be zero backlashes. The other side of the base has three rectangular cross sections to attach the three revolute joints to ensure that the revolute joints are fixed on the base as shown in Figure 3. (Figure 2 shows the assembled wrist prototype)

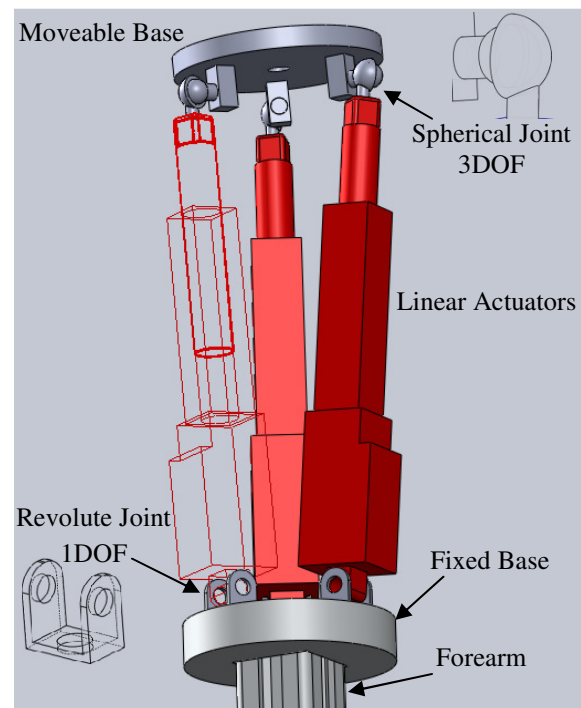

Figure 2. Robotic arm wrist (CAD Model)

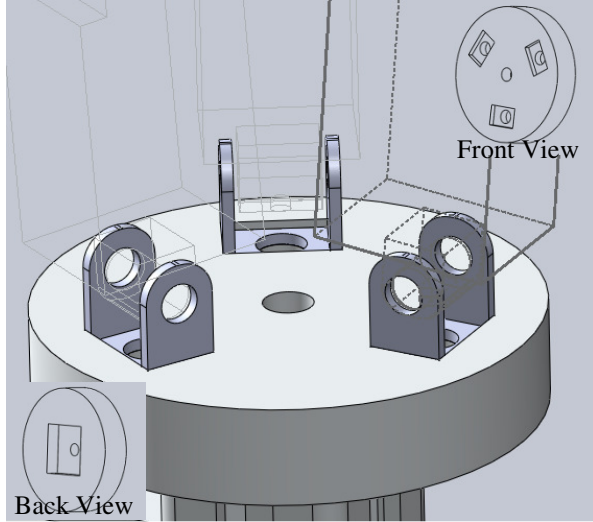

Figure 3. Wrist fixed base (CAD Model)

### III. ACTUATORS DESCRIPTION

A three unique mini Linear Actuators have been attached to the wrist that enables a new generation of motion. For wrist product designs, with capabilities and configuration that have never before been combined in a humanoid wrist these miniature linear actuators have a better option and cheaper than designing awkward gears, motors, and cables. These linear actuators have high flexibility and a rectangular cross section for amplifying stiffness. Each one of these linear actuators had a 43 g weight. In addition it had low voltage and easy to assemble. These linear actuators push or pull loads, and it had a break system that when the power is switched off the actuator will stop moving and stay in the same position, unless if an over loaded have been applied on the actuator, if that is the case the actuator will backdrive. Each leg of the designed wrist had one mounting brackets (revolute joint), two thread with nut and a ball and socket joint that enable the three degree of freedom that is connected to the moveable plate. These three legs are connected to a fixed base and the other side of the leg is connected to the moveable base. Specification of the developed robotic wrist is shown in Table 1.

Table 1. Specification of the Robotic Wrist

Degrees of Freedom	3
Actuators	12V
Wrist Length	116.20mm
Maximum Load	15 N (per actuator)
Type of Material	Aluminum Alloy

### IV. NUMBER OF DEGREE OF FREEDOM

The equation of the serial configuration manipulator to calculate the number of degree of freedom is different from the parallel configuration. The parallel structures have a closed loop which is more complex to calculate the number of degree of freedom.

$$N = \sum_{i=1}^L m_i - \sum_{j=1}^B c_j \quad (1)$$

Equation 1 is a general equation to calculate the number of degrees of freedom for the parallel manipulator structure. And because the kinematic chains between the fixed base and the movable base are identical and have the same number of constraints. Equation 1 will turn out to be:  $(N = n_c d - c_j B)$ . Where  $n_c$  is the number of parallel chains,  $d$  is the sum of degree of freedom of the joints and  $B$  is the number of independent closed loops. To verify the category of joints of each leg in the wrist, to archive the three degree of freedom ( $N= 3$ ), the three legs must be identical and connected to the movable base. From the equation, five degree of freedom must occur in each leg of the wrist namely; four passive and one active degree of freedom to achieve the three degree of freedom in the wrist. The passive degree of freedom distributed in the prototype (1-3), revolute joint 1-DOF on the fixed base and spherical joint 3DOF on the movable base. One active DOF produced by the micro linear actuator.

### V. FEA SIMULATION

SolidWorks is a CAD and simulation software, which is used to model 3D mechanical objects, animates them and mechanical simulation. It is user-friendly software, which allows the user to model 3D things easily. We discuss the finite element results and the procedure of modeling (pre-processing stage). Aluminum profile and aluminum alloy have been selected as the parts material. The main parameters that were justified using SolidWorks software is Von Mises stress, Maximum displacement and the safety factor. The von mises is to obtain the yield stress of the simulated parts. It's important as it provides real life simulated information on whether a part will break under load or not. The deformation analysis is important as well to test of the part have deformation that will affect the performance of the robotic arm. The critical parts in the design of the robotic arm were chosen and simulated to confirm their feasibility. Figure 4 shows the Von Stress Analysis in the movable base (9.7143 MPa) and the fixed base (2.5007 MPa). The results of the two bases in the design are lower than the yield strength of aluminum. The maximum stress can be reduced if the area of the

distributed load is small. For many ductile materials, the onset of yielding takes place when normal stress is equals to yield stress.

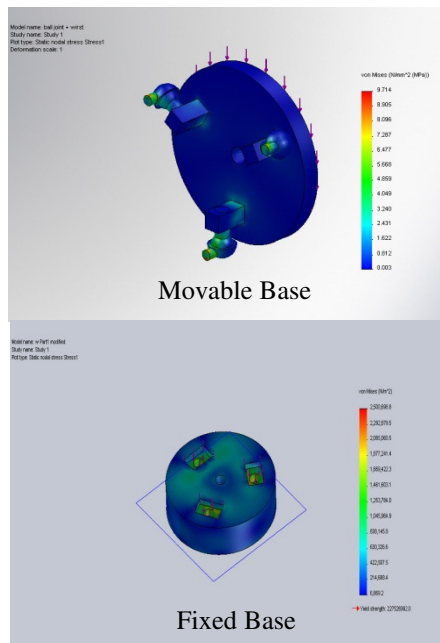

Figure 4. Von Stress Analysis

## CONCLUSION

This paper presents a new model designed for a humanoid robotic wrist. Above all the special steps of the progress process are illustrated. Basing on the basic ideas by using the parallel configuration in the arm wrist, different analyses have been carried out. According to the designed model achieved, it has a lightweight design in the CAD model. This study has achieved the goals of designing an agile 3-DOF humanoid robotic wrist that imitates the movement of a real individual wrist. The next step will be manufacturing the new wrist prototype and assembling it, which is a kind of proof of the concept and this wrist is a part of an on-going project that involves a novel hybrid robotic arm with 7-DOF powered by electrical actuators.

## ACKNOWLEDGMENT

The researchers would like to thank the Ministry of Science, Technology and Innovation (MOSTI) Malaysia for their financial support of this work through the e-Science Fund Project No. 06-02-12-SF0072.

## REFERENCES

[1] Bruno Siciliano, Lorenzo Sciavicco, Luigi Villani, Giuseppe Oriolo, *Robotics Modelling, Planning and Control*, ISBN 978-1-84628-641-4, Springer-Verlag London Limited, (2009)

[2] Mark W. Spong, Seth Hutchinson, and M. Vidyasagar, *Robot Modeling and Control*, First Edition, ISBN: 9780471649908, John Wiley & Sons, INC., pp: 496, (2005)

[3] Huapeng Wu, Heikki Handroos and Pekka Pessi, Mobile parallel robot for assembly and repair of ITER vacuum vessel, *Industrial Robot: An International Journal*, ISSN 0143-991X, VOL 35 · No. 2, pp: 160–168, (2008)

[4] Fontana Marco, Frisoli Antonio, Salsedo Fabio, Bergamasco Massimo, Kinematics of a New 2-DoF Wrist with High Angulation Capability, *IEEE International Conference on Robotics and Automation Orlando, Florida*, pp.1524-1529 (2006)

[5] Peter B. Goldsmith, Design and Kinematics of a Three-Legged Parallel Manipulator, *IEEE Transactions on Robotics and Automation*, Vol. 19, No. 4, pp. 726- 731, (2003)

[6] Raffaele Di Gregorio, Kinematics of the 3-RSR Wrist, *IEEE Transactions on Robotics*, Vol. 20, No. 4, pp.750-754, (2004)

[7] Xianwen Kong, Forward displacement analysis of a 2-DOF RR-RRR-RRR spherical parallel manipulator, *IEEE/ASME International Conference on Mechatronics and Embedded Systems and Applications (MESA)*, ISBN 978-1 -4244-71 01 -0 pp.446-451, (2010)

[8] Minoru Hashimoto, Yuichi Imamura, Design and Characteristics of a Parallel Link Compliant Wrist, *IEEE International Conference on Robotics and Automation*, pp. 2457-2462, (1994)

[9] G. Gogu, Fully-isotropic Three-degree-of-freedom Parallel Wrists, *IEEE International Conference on Robotics and Automation*, 1-4244-0602-1, pp. 895-900, (2007)

[10] HUYNH Patrick, WOON Kok Meng, KO Tai Tong, KWEE Tiaw Joo, Kinematics Analysis and Mechatronics System Design Of a 3-DOF In-Parallel Actuated Mechanism, *Seventh International Conference on Control, Automation, Robotics And Vision (ICARCV'02)*, pp. 950-955, (2002)

[11] ZHU Dachang, ZHU Jianwu, Fang Yuefa, Analysis of a Novel Parallel Manipulator for Rotary Humanoid Wrist Based on Screw Theory, *Proceedings of the IEEE International Conference on Robotics and Biomimetics*, 978-1-4244-2679-9, pp. 983-987, (2008)

[12] Peter Vischer and Reymond Clavel, Argos: A Novel 3-DoF Parallel Wrist Mechanism, *The International Journal of Robotics Research*, (2000)

[13] Raffaele Di Gregorio, Kinematics of the 3-UPU wrist, *Mechanism and Machine Theory*, Elsevier Science Ltd. Vol. 38, pp. 253–263, (2003)

[14] Youxin LUO and Qiyuan LIU, Chaotic Finding Method of Position Forward Kinematics of 3-DOF Parallel Robot, *Third International Symposium on Intelligent Information Technology Application*, IEEE society, pp. 44-47, (2009)

[15] Choon seng Yee, Kah-bin Lim, Forward kinematics solution of Stewart platform using neural networks, Vol. 16, pp. 333-349, (1997)

[16] Gareth Branwyn, *Absolute Beginners Guide to Building Robots*, ISBN 0-789729717, (2004)

[17] Paul E. Sandin, *Robot and Mechanical Devices Illustrated*, McGraw-Hill, ISBN 0-07-141200-X, (2003)

[18] Seok-Hee Lee, Whee-Kuk Kim, Se-Min Oh and Byung-Ju Yi, Kinematic Analysis and Implementation of a Spherical 3-Degree-of-Freedom Parallel Mechanism, *Intelligent Robots and Systems, IEEE/RSJ International Conference*, pp.972-977, (2005)