

## Strength characteristics of sealer devices at design stage

This content has been downloaded from IOPscience. Please scroll down to see the full text.

2016 IOP Conf. Ser.: Earth Environ. Sci. 43 012083

(<http://iopscience.iop.org/1755-1315/43/1/012083>)

View [the table of contents for this issue](#), or go to the [journal homepage](#) for more

Download details:

IP Address: 92.63.72.98

This content was downloaded on 10/12/2016 at 04:43

Please note that [terms and conditions apply](#).

You may also be interested in:

[Effect of Different Coarse Aggregate Sizes on the Strength Characteristics of Laterized Concrete](#)

M A Salau and A O Busari

[Evaluation of Strength Characteristics of Laterized Concrete with Corn Cob Ash \(CCA\) Blended Cement](#)

E E Ikponmwo, M A Salau and W B Kaigama

[Serafim Nikolaevich Zhurkov \(on his eightieth birthday\)](#)

A P Aleksandrov, Zhores I Alferov, G V Kurdyumov et al.

[The development of a sapphire cell for neutron scattering experiments at high temperature and high pressure](#)

L Walker, C Luttrell, L Solomon et al.

[Warm electrons in quantum well wires](#)

S S Kubakaddi, B G Mulimani and V M Jali

[Effect of severe plastic deformation on the structure and mechanical properties of Al-Cu-Mg alloy](#)

E Khafizova and R Islamgaliev

[NanoSPD activity in Ufa and International Cooperation](#)

N Reshetnikova and M Salakhova

[Investigation of the surface layers of solids by electron spectroscopy](#)

V A Trapeznikov

[Microstructure and mechanical properties of ultrafinegrained Mg-Zn-Ca alloy](#)

Olga Kulyasova, Rinat Islamgaliev, Yonghao Zhao et al.

## Strength characteristics of sealer devices at design stage

V G Butov<sup>1</sup>, K A Golubeva<sup>1</sup>, V K Nikulchikov<sup>1</sup> and A A Yashchuk<sup>2</sup>

<sup>1</sup> National Research Tomsk Polytechnic University, 30, Lenin Ave, Tomsk, Russia

<sup>2</sup> National Research Tomsk State University, 36, Lenin Ave, Tomsk, Russia

E-mail: <sup>1</sup> nikulchikov@tpu.ru, <sup>2</sup> rainbow@niipmm.tsu.ru

**Abstract.** The paper deals with strength characteristics of several sealer devices used to seal the inner cavity of an oil pipeline during the replacement of a pipeline section. Construction calculations revealed the stresses related to the pressurized rubber-cord sealing element rupture resulted from an emergency situation. It was concluded that it is necessary to test the operating parameters before applying the sealers. Estimation of the safety factor of existing sealer devices designs was conducted and recommendations for its increase were proposed.

### 1. Introduction

Nowadays the environmental policy of petroleum industry enterprises aims at improving environmental management, environmental protection and environmental safety with regard to the requirements of ISO 14001:2004 standard.

The priority tasks of the enterprises include the reduction of risk of pipeline accidents having environmental consequences and timely repair of pipelines, during which the sealer devices needs to be used for sealing the inner cavity of pipeline.

The design of sealer devices requires structural strength assessment taking into account the stresses arising from the rupture of rubber-cord sealing member in a possible emergency situation.

Structural scheme of the sealer device for covering the inner cavity of DN 400/500/800/1000/1200 pipelines is shown in figure 1 [1].

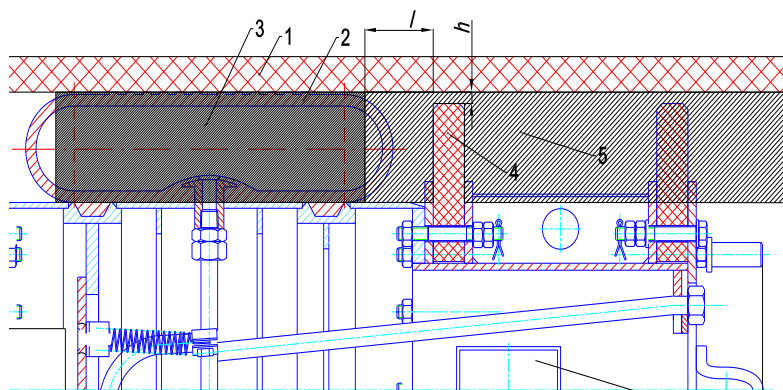

**Figure 1.** Structural scheme of oil pipeline sealer device and FVM model domains:

1 – pipeline; 2 – sealing member; 4 – aligning bearing; 3 – domain with initial operating pressure; 5 – domain with atmospheric pressure.

## 2. Research approaches

The finite element method was used to calculate the stress-strain state of the sealer device body under the pressure pulse caused by sealing member rupture [2, 3]. The ANSYS Mechanical software was applied in numerical calculations.

The finite element model was built with second order integration elements. Due to the symmetry only 1/6 part of the device body needs to be analyzed. The model takes into account only those structural elements and welded joints which have a considerable influence on the stress-strain behavior of the body. T-bar and butt welds connecting body structural elements with the flange are the most stressed elements in case of the pressure pulse from sealing element rupture. Therefore, the stress-strain state of these joints was given particular attention when analyzing the calculation results.

The following boundary conditions were applied to the model:

- the edges of holes for bolts securing body to the core was rigidly fixed;
- pressure on aligning bearing side facing the core.

The following physical properties of steel were used [4]: Young modulus of 210 GPa, Poisson's ratio of 0.3, density of 7900 kg/m<sup>3</sup> and yield stress of 245 MPa.

According to [5], the following allowable stresses were used when analyzing the results:

- nominal allowable stress of the parent material 140 MPa;
- nominal allowable stress of butt weld 126 MPa.

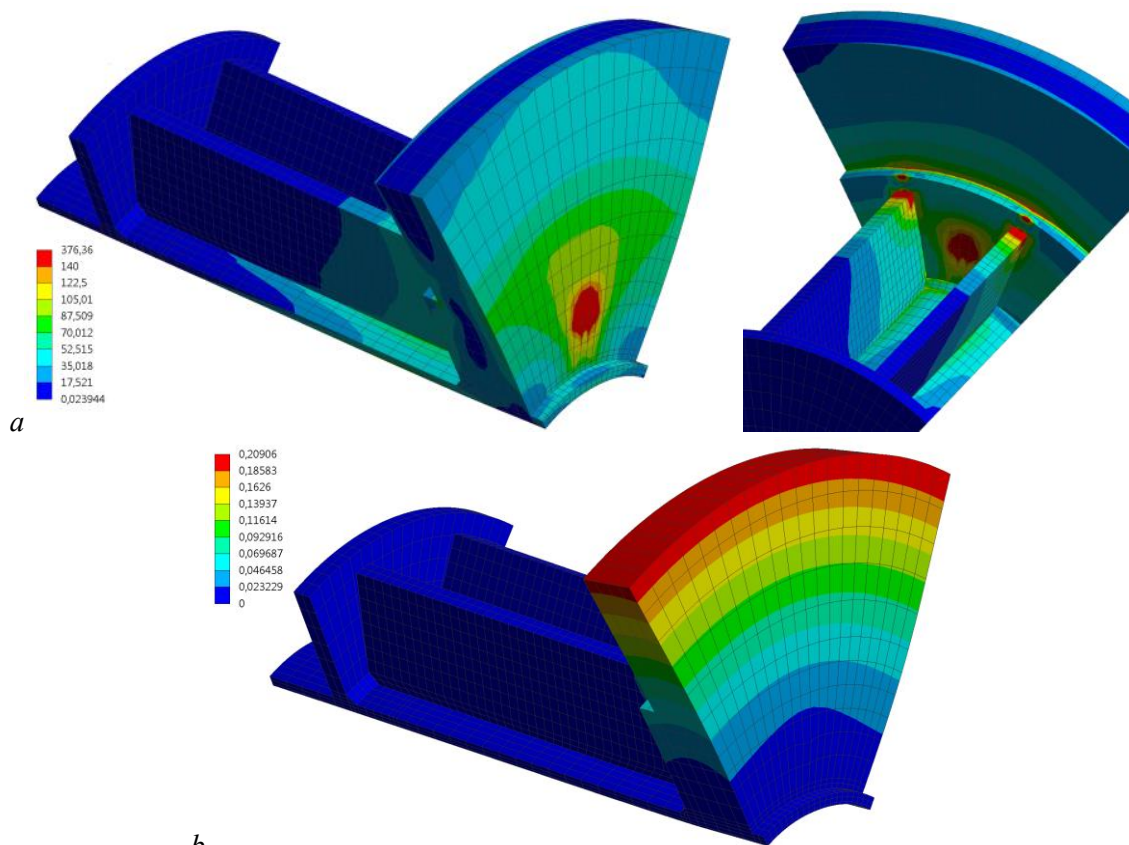

**Figure 2.** Stress-strain behavior of DN 400 sealer device under static load:  
*a* – von Mises stress, MPa; *b* – total displacements (scaled up), mm.

### 2.1. Elastic approach

First, we assess the strength of the body according to standard engineering procedures. In this approach, the model of the elastic body material and the maximum possible excess pressure of the shock wave accounting for its dynamic nature were used.

The maximum overpressure caused by the shock wave can reach 1.95 MPa, under the operating pressure of 2.05 MPa in the sealing member.

As this overpressure is applied to the support almost instantaneously (the natural period of the body is approximately  $(0.5-3) \cdot 10^{-3}$  s while upslope time of the shock wave is  $\sim 5 \cdot 10^{-5}$  s), it is necessary to take into account the impact effect of the load. Theoretical dynamic amplification factor of the instantaneous load is 2 [6], in practical calculations it is recommended to use the value of not less than 1.5 [5]. Thus, the overpressure was set to 3.9 MPa.

The results of elastic approach are presented in figures 2 and 3. In the equivalent stress contour plots the red color indicates regions with stresses exceeding the values allowed by [5]. It should be noted that the evaluation based on engineering approach suggests the possible breakage of the device.

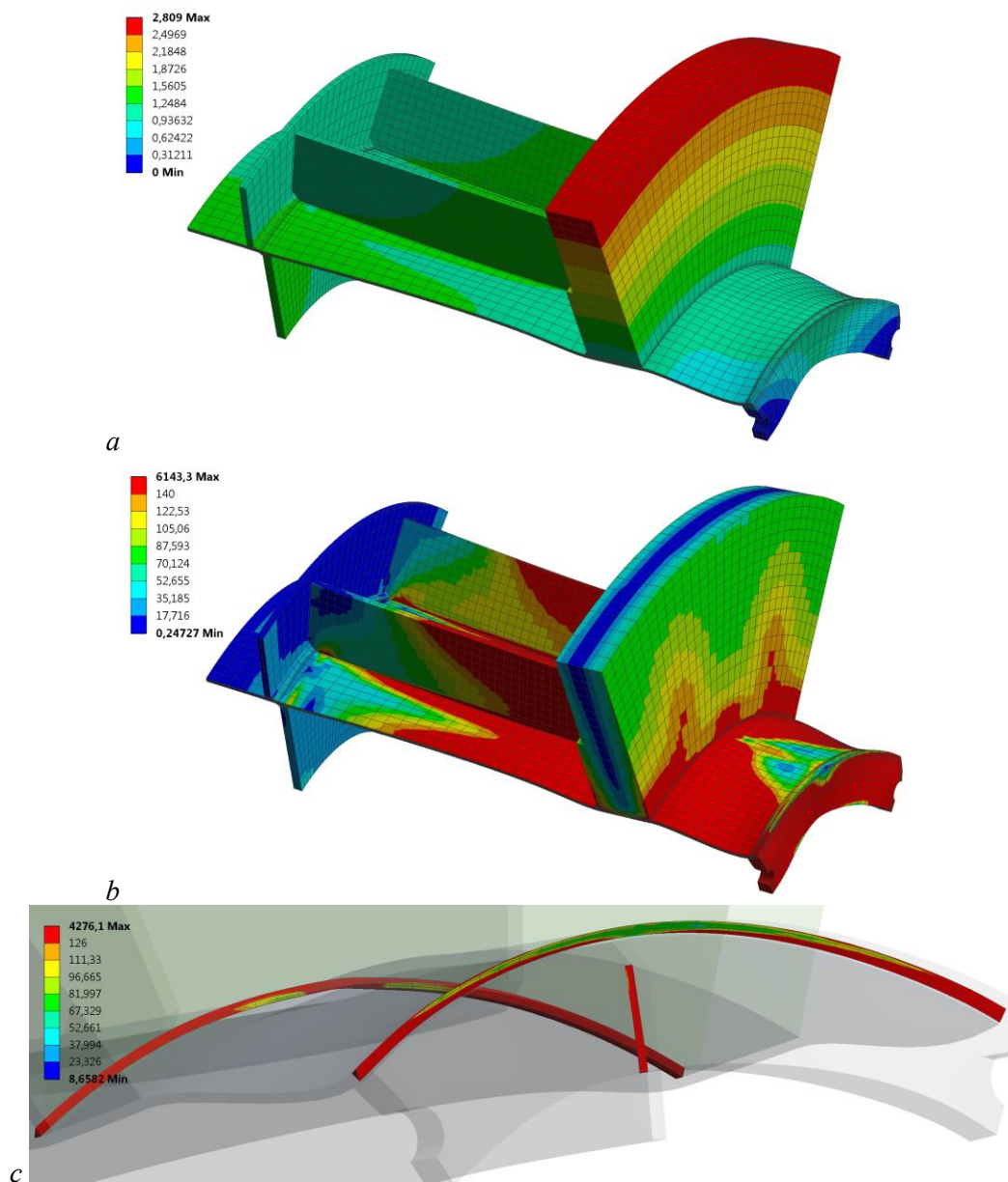
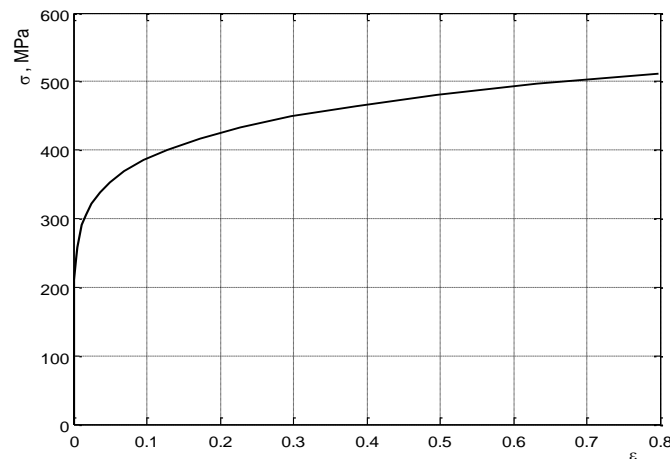

**Figure 3.** Stress-strain behavior of DN 1200 sealer device under static load:  
*a* – total displacements (scaled up), mm; *b* – von Mises stress, MPa;  
*c* – von Mises stress in most loaded welded joints, MPa.

## 2.2. Elastoplastic approach

More rigorous and close to real-life calculations were based on elastoplastic material model [7]. Multilinear isotropic hardening material model used the following additional steel properties: strength limit of 370 MPa and reduction of area at fracture of 55% (figure 4).

The results of elastoplastic calculations for DN 400 sealer device are presented in figure 5. The figure shows that there are no stresses close to the strength limit, thus the DN 400 sealer device is capable of withstanding the pressure pulse caused by the sealing member rupture.



**Figure 4.** The stress-strain curve for steel.

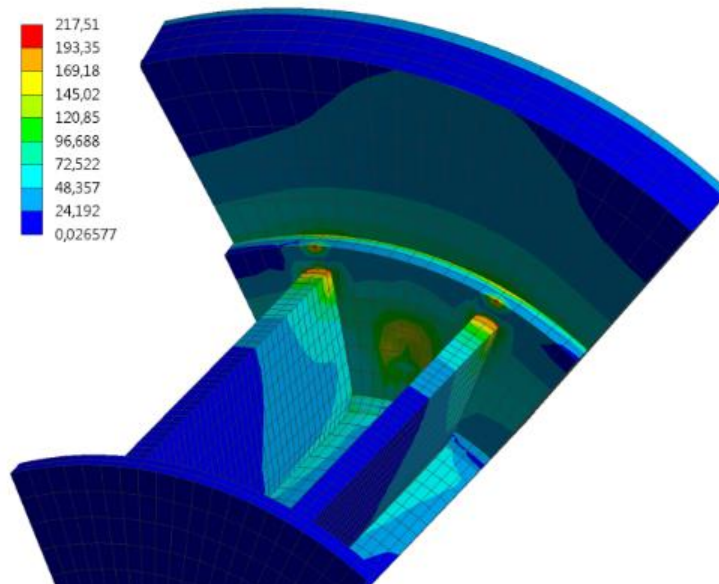

**Figure 5.** Von Mises stress in DN 400 sealer device, MPa.

The numerical solution for DN 1200 sealer device with the overpressure of 39 atm is non-converging, apparently indicating breakage. The results of elastoplastic calculations for DN 1200 sealer device with 15 atm overpressure (maximum value for which the numerical solution could be obtained) are presented in figure 6. As in the figures herein above, the red color indicates regions with stresses and strains exceeding the allowed values. The results show that plastic strains in most of the aforementioned welds exceed the allowable limit.

### 3. Results and discussion

The results of the calculations should be taken into account when designing oil pipeline sealer devices with rubber-cord sealing element.

1. The results based on elastic approach using the upper estimate of overpressure give the equivalent stresses in the body of DN 400 sealer device exceeding the maximum allowable values according to [5]. For the DN 1200 sealer device the equivalent stresses in all the welds connecting the body with the flange exceed the maximum allowable values.

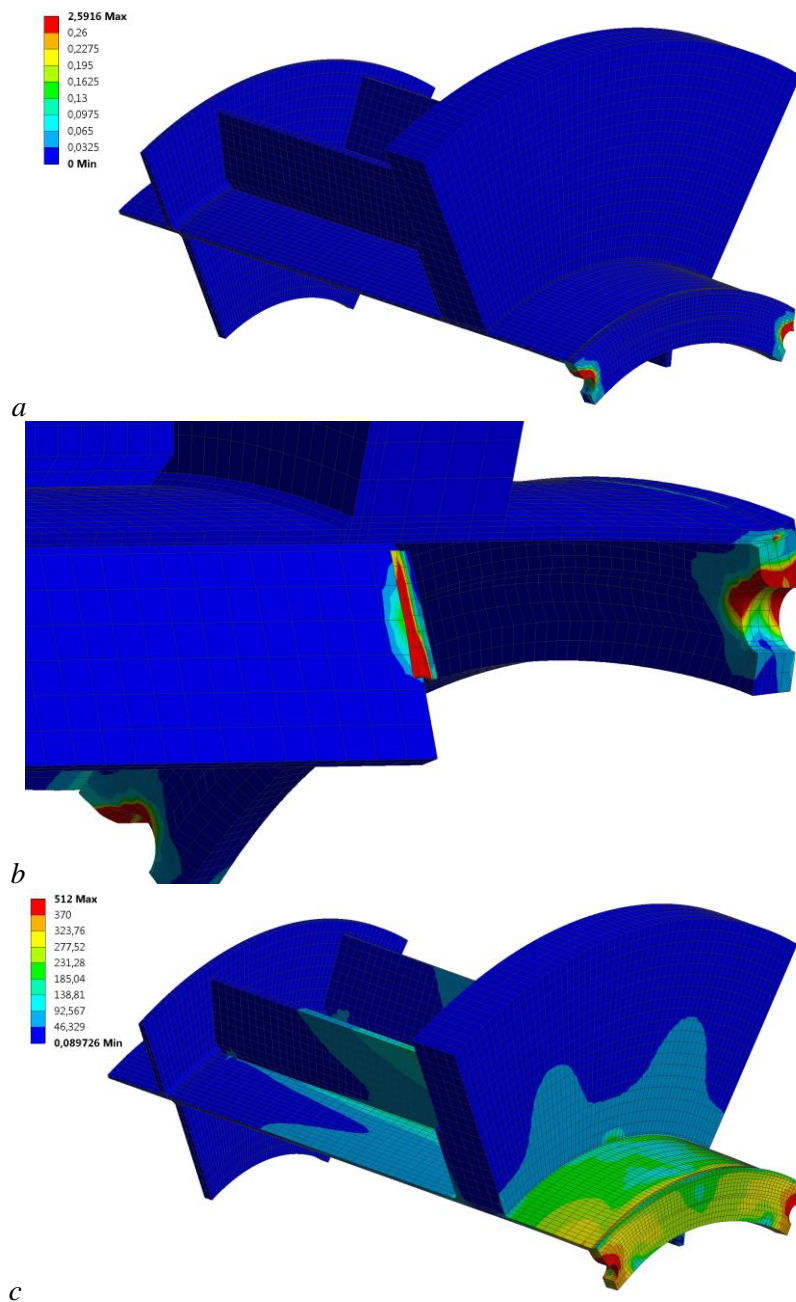

**Figure 6.** Elastoplastic stress-strain behaviour of DN 1200 sealer device: a – equivalent plastic strain; b – equivalent plastic strain in most loaded regions; c – von Mises stress, MPa.

2. Numerical calculation based on elastoplastic approach reveals that stresses occurring in the DN 400 sealer device exceed yield stress, but are less than the strength limit. Thus, in an emergency situation there will be an irreversible deformation of the device without its destruction. Therefore, the DN 400 sealer device has sufficient strength to ensure safety in a case of emergency (the case of a pressurized sealing member rupture).

3. Numerical calculation based on elastoplastic approach reveals that the stresses occurring in the DN 1200 sealer device exceed the strength limit, thus the device will break down in an emergency situation.

#### 4. Conclusions

The results for the DN 1200 sealer device suggest that the safety factor is less than 1. In order to increase the safety factor to a safe level it is necessary to ensure the strength of the connections of the sealer elements:

1. Increase the strength of the T-bar welded joints connecting the ribs with the flanges.
2. Increase the strength of the butt welded joints connecting the body with the flanges.
3. If necessary, increase the strength or number of bolts connecting the flanges to the core.
4. Consider other ways of connections used in the sealer design. For example, it is possible to use additional connection of the flanges by stud-bolts and nuts instead of T-bar welded joints. Another option is to extend the bolts connecting the body with the core to the flange and thus replace the stud-bolts proposed above.

#### 5. References

- [1] Brezgin A E, Denisov F M and Siciak M M 2004 Device for reusable sealing of the pipeline's open end, RF Patent no. 2240466
- [2] Zienkiewicz O C 1977 *The Finite Element Method* (London: McGraw-hill)
- [3] Burkov P V, Burkova S P and Kravchenko A N 2015 *IOP Conference Series: Materials Science and Engineering*. Finite Element Model of Trenchless Pipe Laying. Vol. **91** pp. 012052.
- [4] Anuryev V I 2001 *Moscow. Mashinostroenie*. A Handbook for Designers and Mechanical Engineers. Vol. **1**
- [5] Laschinsky A A and Tolchinsky A R 1970 *Leningrad. Mashinostroenie*. Fundamentals of Design and Calculation of Chemical Equipment.
- [6] Darkov A V and Shapiro G S 1975 *Strength of Materials* (Moscow: Higher School)
- [7] Gokhfel'd D A, Getsov L B and Kononov K M 1996 *Reference book. Ekaterinburg: Ural Branch of Russian Academy of Sciences*. The Mechanical Properties of Steels and Alloys in Unsteady Loading.