

# IRRIGATSIYA va MELIORATSIYA

№(1).2019

*Journal of Irrigation  
and Melioration*

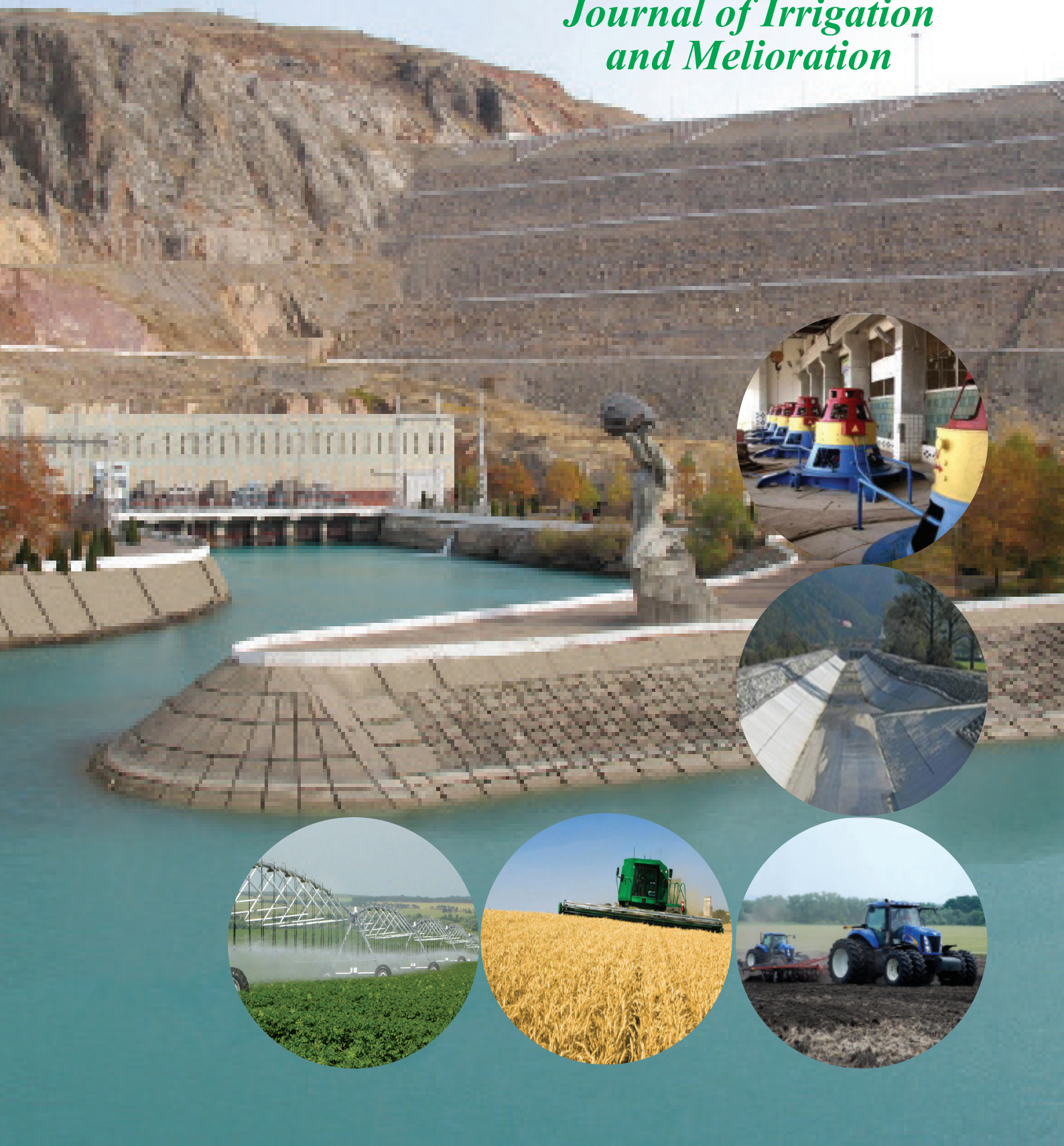

## IRRIGATION AND MELIORATION

- Khamidov M.Kh., Nazaraliev D.V., Balla D., Hamidov A.M.  
**SOIL PROTECTION AND WATER-SAVING TECHNOLOGIES IN AGRICULTURAL CROPS  
IRRIGATION ON ERODED SOILS.....4**
- Serikbaev B.S., Sherov A.G., Fatkhulloev A.M., Gafarova A.I., Mihalikova M.  
**MODERNIZATION OF IRRIGATION SYSTEMS MANAGEMENT TO IMPROVE THEIR RELIABILITY.....8**
- Abdurakhmanov B.U., Karimov A.Kh., Amirova I.A.  
**WATER AND POWER PRODUCTIVITY OF GRAPE PRODUCTION IN FERGANA VALLEY.....11**

## HYDRAULIC ENGINEERING STRUCTURES AND PUMPING STATIONS

- Mirsaidov M.M., Sultanov T.Z., Yuldoshev B.Sh., Kisekka Isaya  
**ESTIMATION OF EARTH DAMS DYNAMICS OF UNDER MULTICOMPONENT KINEMATIC EFFECT.....16**
- Bacchelli M., Lilliu G.  
**THE USE OF GEOMEMBRANES TO INCREASE EFFICIENCY, RELIABILITY AND SAFETY OF  
HYDROTECHNICAL STRUCTURES.....21**
- Mirsaidov M.M., Sultanov T.Z., Yarashov J.A., Toshmatov E.S., Yuldoshev B.Sh., Takhirov S.M., Rumi D.F.  
**ASSESSMENT OF STRESS-STRAIN STATE OF EARTH DAMS WITH ACCOUNT FOR  
GEOMETRICAL NONLINEARITY UNDER STATIC LOADS.....26**
- Yangiev A.A., Adzhimuratov D.S., Kovar P.  
**THEORETICAL STUDIES OF SWIRLING FLOW RATES FOR A CONFUSER SECTION OF  
HIGH-PRESSURE VORTEX MINE SPILLWAYS.....31**
- Kan E.K., Orekhov G.V.  
**ENERGY LOSS BALANCE IN A CENTRIFUGAL PUMP WHEN THE ROTATION SPEED OF THE  
IMPELLER CHANGES.....36**
- Mamazhanov M., Uralov B., Khidirov S., Siderenko G.I.  
**THE EFFECT OF HYDROABRASIVE WEAR OF CENTRIFUGAL AND AXIAL PUMPS UNITS ON  
OPERATION EFFICIENCY OF IRRIGATING PUMPING STATIONS.....40**

## ELECTRIFICATION AND AUTOMATION OF AGRICULTURE AND WATER RESOURCES MANAGEMENT

- Isakov A.J., Ochilov D.V., Kadbin N.E.  
**INCREASE OF THE EFFICIENCY AND RATIONAL USE OF ELECTRICAL ENERGY AND  
ELECTRICAL EQUIPMENT.....45**

## ECONOMICS OF WATER MANAGEMENT AND USE OF LAND RESOURCES

- Chertovitsky A.S., Narbaev Sh.K., Shapira M.  
**TASKS ON LAND USE MODERNIZATION IN UZBEKISTAN UP TO 2030.....48**



# MODERNIZATION OF IRRIGATION SYSTEMS MANAGEMENT TO IMPROVE THEIR RELIABILITY

Serikbaev B.S<sup>1</sup>., Sherov A.G<sup>1</sup>., Fatkhulloev A.M<sup>1</sup>., Gafarova A.I<sup>1</sup>., Mihalikova M<sup>2</sup>.

<sup>1</sup>Tashkent Institute of Irrigation and Agricultural Mechanization Engineers (Uzbekistan)

<sup>2</sup>Czech University of Agriculture (Prague)

## Abstract

Results of many years of theoretical, operational and reclamation studies conducted in various climatic-economic conditions of the Republic of Uzbekistan are presented in the paper. Based on the research and experience data of developed countries, recommendations have been developed for modernizing the management of irrigation systems based on the cybernetic scheme model in order to increase the reliability coefficients of all parts of the system, as well as to increase the reliability coefficient and coefficient of performance (COP) of the Lower Syrdarya irrigation system.

**Key words:** Modernization of irrigation system management, reliability, cybernetic scheme, limit water use, main canal, WUA (Water users association) farming, crop, irrigation rate, river, operation and automation of irrigation-ameliorative systems.

**Introduction.** A system of measures to modernize the management of irrigation systems in Uzbekistan is being systematically carried out:

- organization of targeted rational use of water resources in all sectors of the economy based on the introduction of innovative equipment and technology for limit water use;
- implementation of a unified technical policy in the water sector. implementation of innovative resource-saving equipment and crop irrigation technology;
- ensuring the technical reliability of irrigation systems, etc.

In his speech to the UN General Assembly on September 19, 2017, the President of our republic, Sh.M.Mirziyoyev, drew a special attention to the importance of rational use of water resources of the transboundary Rivers Syrdarya and Amudarya.

Analysis of the current state of the problem. In the current conditions of global climate change and the transition of transboundary rivers to an irrigation-energy regime, it becomes necessary to use a cybernetic scheme for managing the operation and automation of irrigation systems.

The scheme is introduced in the following spheres:

- Management of irrigation systems based on technical facilities;
- Management of irrigation systems based on biological indices of the objects;
- Water resources management on the basis of scientifically sound limit water use;
- Ensuring the reliability of all sections in irrigation systems.

Technical facilities include the objects of irrigation and ameliorative system: water-systems, head water intake structures, main canals, inter-farm canals and canals of in-farm systems. It is known that the irrigation system consists of a conductive (supply) and regulatory part.

Biological regulation objects include: the use of advanced crop cultivation technologies to obtain high and environmentally sound crops, new varieties of crops, advanced agricultural, forestry measures, the introduction of repeated sowing [1].

Organization and implementation of all stages of

water management from the irrigation source to the water outlet points in farming, followed by irrigation flow distribution and ensuring the work of irrigation equipment and irrigators to obtain high crop yields, is called water use.

Statement of the problem. The essence of water use planning is to determine the volume of water intake from the irrigation source, transportation and its subsequent distribution between farms –the water users - in accordance with a pre-compiled irrigation plan. The volume of water intake in the head of the irrigation system should be determined in strict accordance with the need for water of the water consumers served by this system. The final result of water use planning is the drawing up the limit water use plans, taken as the basis for the operational management of water resources both in the irrigation system as a whole and in its individual sections.

Each irrigation system should have its own optimal type of land reclamation and operation of irrigation systems, the use of which will formulate a balanced cultural landscape, meeting environmental and sanitary-epidemiological requirements.

Ensuring the reliability of irrigation and ameliorative systems is a priority when improving the operation of the irrigation system. Planned and round-the-clock water use for irrigation depends on the reliable operation of irrigation canals and water supply systems, hydro-technical structures, pumping stations, a chute network of pipelines, irrigation equipment, etc.

The reliability of operation is the certainty of ensuring the design characteristics of equipment and the design efficiency of operation at a set time. A reliability criterion is a failure-free and well organized operation of irrigation facilities and their readiness for work.

The certainty of failure-free operation of the system for a set period of time is determined by M.F.Natalchuk formula [2]:

$$P = e^{-\lambda t},$$

where: P – is the reliability (certainty) in fractions of a unit; e= 2.71;  $\lambda$  is the failure ratio; t is the duration of system operation.

Meantime between failures (MTBF) is a mean time of failure-free operation

$$T = \frac{1}{\lambda},$$

Failure ratio is the mean number of failures per unit of time

$$\lambda = \frac{1}{T},$$

Technical resource is the total duration of failure-free operation of the system, from the start of operation to the limit state (wear),  $T_r$  is the coefficient of technical use of the system (the ratio of technical resource to the sum of terms: technical resource, duration of repairs and adjustments), determined by M.F.Natalchuk formula:

$$K_{\text{tr}} = T_r / (T_r + T_p + T_H)$$

where:

$T_r$  - is the coefficient of technical use of the system;

$T_p$  - are the technical resources;

$T_H$  - is the duration of repairs and adjustments.

The reliability under normal operation is achieved by wear-in of all elements during the initial operation; prevention and replacement of individual units under wear; specification of the operating rules after the mean life of the units (under wear).

The irrigation system operates reliably during preventive maintenance, under systematic control and adjustment of actions, timely repair and replacement of units under wear. The system must have reserves to eliminate failures.

The schedules are made for each type of service, indicating the time spent on work. When designing and calculating facilities (devices), the reliability is assessed by analogy with existing systems: by system options and by the main accepted option; by constituent elements of the main option; based on tests of constituent units and refinement of the reliability indices.

**Solution methods.** The reliability of the system facilities increases when there are the reserves, a decrease in number of system units (nodal diagram), a decrease in the failure rate and time for maintenance and repair, and leveling of unit durability and the failure rate of the components that make up the system. The main provisions of the theory of reliability are as follows:

The reliability of system equals to the product of the reliability of the system  $P_c = P_1 P_2 P_3 \dots P_i^n$ ;

The reliability of the system decreases with an increase in the number of units; with the nodal scheme of the system, the reliability is higher.

System reliability improves when connecting reserve units

$$P_c = |1 - (1 - P_i)^m|^n,$$

where:  $n$  is the number of units;  $(m-1)$  is the number of reserve elements;  $P_i$  is the reliability of one unit.

Reserve elements ensure a stable reliability of the system. The capital costs of improving the units ( $C$ ) and the reliability of the system ( $P$ ) are estimated by the ratios (in relation to machines):

$$C_1 = C \frac{(1 - P)P_1}{P(1 - P_1)}.$$

At  $P=0.85$  and  $P_1=0.9$  this ratio is  $C_1 = 1.58C$ . At an increase in the system reliability from 0.85 to 0.9, an increase in capital costs should equal to 1.58 times.

Analysis of the results and examples. In irrigation systems operation the following aspects should

be determined: there liability of the irrigation and operational devices of irrigation equipment during the vegetation period, the reliability of planned distribution and use of water consumption for irrigation of land of WUA, farms; and other measures to ensure the reliability of irrigation systems.

Technical-economic indices of the reliability of irrigation systems are: production rate, maintenance and repair costs, durability, high crop yields, high values of COP (efficiency), Land use ratio (LUR), Water utilization rate (WUR), productivity of one cubic meter of irrigation water, low cost of gross yield, etc.

At present, to achieve this goal, cybernetic control schemes for operational automation of irrigation systems have been developed. The authors of cybernetic control schemes are Norbert Wiener, Professor Natalchuk M.F., Professor Bochkarev Y.V., Professor Ovcharov E.E., Professor Serikbaev B.S. and others who have proved and justified the need for a complex work on the operation and automation of irrigation systems based on the cybernetics - the science of management [3,4,5].

The cybernetic control scheme for the operation and automation of irrigation systems is shown in Fig. 1.

MWRRUz - Ministry of Water Resources of the Republic of Uzbekistan

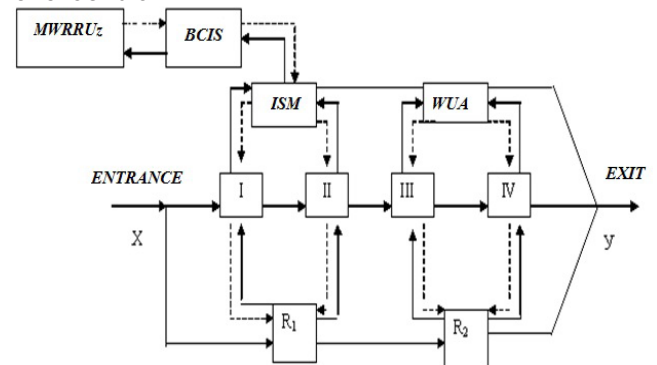

**Fig. 1. Cybernetic control scheme for the operation and automation of irrigation systems**

BCIS - bass control irrigation systems

ISM - irrigation systems management

WUA - Water users association

**Notations:** X - Entrance to the system, this concept includes all hydro-technical structures, water-systems, the head water intake facility, designed to take water in the right quantity and quality and in the right water horizon in the conductive part of the canal.

U - Exit from the system; I - Head water intake facility;

II - Irrigation systems irrigation systems management (ISM) and bass control irrigation systems (BCIS);

III - Irrigation systems of Water users association (WUA) and farms; IV - Irrigation equipment; R<sub>1</sub> - Reserve of water, technical, material, financial, labor and other resources for irrigation systems management (ISM) and bass control irrigation systems (BCIS); R<sub>2</sub> - the same for the in-farm sector of Water users association (WUA) and farms;

- communication line; - line of impact.

The criterion to assess the irrigation management modernization is: - Improving the reliability of all units of irrigation systems; - Increasing the efficiency of irrigation systems. Values:

$$\eta_{is} = \frac{\bar{M}^{net}}{\bar{M}^{br}}.$$

where:  $\bar{M}^{net}$  is the net average irrigation rate of crops, m<sup>3</sup>/ha;  $\bar{M}^{br}$  is the gross average irrigation rate of crops, m<sup>3</sup>/ha.

In recent years, according to our field studies, the calculated values of the efficiency of the Lower Syrdarya Basin Management of Irrigation Systems (LSBMIS) amounted to  $\eta_{uc} = \frac{\bar{M}^{net}}{\bar{M}^{br}} = \frac{8400}{10500} = 0,80$ . The values of the reliability coefficient of irrigation systems amounted to  $0,90 \div 0,92$ .

**Conclusions and recommendations.** Under the current conditions of global climate change and the transition of the transboundary rivers Amu Darya and Syr Darya to the irrigation-energy regime, an innovative modernization of irrigation system management is necessary in our republic.

An innovative system for modernizing the irrigation system management is a transition to a complete cybernetic scheme for managing the operation and automation of irrigation systems.

Technical- economic indices of cybernetic scheme implementation to manage irrigation systems are: high reliability and safety of irrigation systems during their operation, durability, high values of efficiency, Land use ratio (LUR), water utilization rate (WUR) of irrigation systems, high productivity of one cubic meter of irrigation water, low cost of gross yield and stable high GDP values.

According to our field studies, the calculated values of the efficiency of the Lower Syrdarya Basin Management of Irrigation Systems (LSBMIS) amounted to  $\eta_{uc} = 0,80$ . The values of the reliability coefficient of irrigation systems amounted to  $0,90 \div 0,92$ .

#### References:

1. Kolpakov V.V., Sukharov I.P. *Sel'skokhozyaystvennyye melioratsiya* [Agricultural melioration]. Moscow, 1981. Pp. 165-169.
2. Natalchuk M.F., AkhmedovKh.A., Olgarenko V.A. *Ekspluatatsiya gidromeliorativnykh system* [Operation of irrigation and drainage systems]. Moscow, 1983. Pp. 86-92.
3. Serikbaev B.S., Barayev F.A. *Praktikumpo EAGMS* [Workshop on EAGMS]. Tashkent. Mekhnat. 1996. P. 18-23.
4. Serikbaeva E.B. *Problemy uluchsheniya vodopol'zovaniya v bassejne Aral'skogo morya* [Problems of improving water use in the Aral Sea basin]. Agriculture corrodes Science fact. Tashkent. 2001. P. 136-138.
5. SerikbaevB.S., GostishchevD.P. *EGMS*. Tashkent. 2013. P. 24-29.
6. Umurzakov U.P., Abdurakhimovi.A. *Suv khozhraligi menezhmenti* [Water management]. Tashkent. 2008. Pp. 438-439.
7. Dukhovny V.A. *Peredovyetendentsii v upravlenii vodnymi resursami sovremennogo mira primenitel'no k Tsentral'noy Azii* [Advanced trends in the management of water resources in modern world in relation to Central Asia]. Moscow, 1980. Pp. 8-18.
8. SerikbaevB.S. *Ekologicheskaya ustoychivost' vodnymi resursami v bassejne Aral'skogo morya* [Ecological sustainability of water resources in the Aral Sea basin]. International scientific - practical conference. Kazakhstan. Almaty. 2003. P. 115-117. [in Russian]
9. SerikbaevB.S., SerikbayevaE.B., Omarova G.E. *Analiz sostoyaniya zagryaznennosti poverkhnostnykh vodnykh resursov rek Aralo-Syrdar'inskogo basseyna* [Analysis of the state of contamination of surface water resources of the Aral-Syrdarya river basin] "Problems of Ecological Safety in Economics", International Scientific and Practical Conference. Kazakhstan. Taraz. 2017. P. 115-119.
10. SerikbaevB.S., SennikovM.N., OmarovaE.O., OmarovaG.E. *Innovatsionnyye preobrazovaniya sostoyaniya gidrologicheskikh ugroz transgranichnykh rek RK* [Innovative Transformation of the State of Hydrological Threats of Transboundary Rivers of the Republic of Karelia] "Problems of Ecological Safety in the Economics", International Scientific and Practical Conference. Kazakhstan. Taraz. 2017. P. 119-123.
11. SerikbaevB.S., AbdrasulovD., MukhtarovJ. *Plotinnyy vodozabordonnymi napravlyayushchimi porogami* [Dam water intake with bottom guiding thresholds] "Problems of ecological safety in economics" International scientific - practical conference. Kazakhstan. Taraz. 2017. P. 75-78.
12. SerikbaevB.S., BarayevF.A., GulomovS.B. *Nadezhnost' system kapel'nogo orosheniya* [Reliability of drip irrigation systems] *Journal of Irrigatsiya va Melioratsiya*. Tashkent. 2017. №. 4(10) Pp. 10-12.
13. Serikbaev B.S., Egamberdieva Sh. *Vodopronitsaemost' pochv pri polive khlopchatnika s sovmeshchennymi posevami masha i asoli* [Water permeability of soils during watering of cotton with combined crops of mung beans and kidney beans] *Journal of Agro-Ilm*. Tashkent. 2018. №. 1(51) P. 68-69. [in Russian]
14. BochkarevYa.V., OvcharovE.E. *Osnovy avtomatiki i avtomatizatsii proizvodstvennykh protsessov v gidromelioratsii* [Basics of Automation and Automation of Production Processes in Hydromelioration]. Moscow. 1981. Pp. 113-117.
15. Barayev F.A., KhamidovM.Kh. *Ekologo-meliorativnyye problem v bassejne reki Syrdar'ya* [Ecology-ameliorative problems of Syrdarya river basin]. *Journal "Water recourse of Central Asia"* Tashkent. 2000. №1, P. 84-87.
16. SherovA.G., TurdimurodovaZ. *Effektivnyy priemulucheniya i podderzhaniya blagopriyatnoy ekologo-meliorativnoy obstanovki na zemlya kh podverzhenny kh zasoleniyu* [Effective procedure of improvement and maintenance of favorable ecological- ameliorative conditions on soils susceptible to salification] "Modern Problems of Agriculture and Water Management The Republican scientific - practical conference. Tashkent. 2013. Pp. 242-243.
17. Kostyakov A.N. *Osnobymelioratsii* [Fundamentals of land improvement]. Moscow. 1960. Pp. 621.
18. SherovA.G. *Vodoychet v malykhkanalakh* [Water accounting in small channels]. "Water resources of Central Asia and their use" International Scientific and Practical Conference. Kazakhstan, Almaty. 2016. Pp. 268-270.
19. Shumakov B.A. *Oroshaemoezemledelie* [Irrigation agriculture]. Moscow. 1965. Pp. 216.
20. Sherov A.G., Kodirova L. *Chto takoe diversifikatsiya sel'skokhozyaystvennykh kul'turi ee znachenie v povyshenii prodovol'stvennoy bezopasnosti* [What is the diversification of agricultural crops and its importance in improving food security]. "Modern Problems of Agriculture and Water Management The Republican scientific - practical conference. Tashkent. 2013. P. 54-57.