

COMBINED CLONAL NEGATIVE SELECTION ALGORITHM FOR DIAGNOSTICS OF COMBUSTION IN INDIVIDUAL PC BURNER

Andrzej Smolarz¹, Volodymyr Lytvynenko², Olga Kozhukhovskaya³, Konrad Gromaszek¹

¹Lublin University of Technology, Institute of Electronics and Information Technologies, ²Kherson National Technical University, Department of Informatics & Computer Sciences, ³Cherkasy State Technological University, Department of Computer Systems

Abstract. In pulverised coal (PC) burners that are most widespread in Poland an individual air excess ratio rules an amount of pollution generated, yet there is a lack of method that allows measurement of output parameters of a burner. It is therefore necessary to use indirect methods, which could primarily include acoustic, and optical methods. These methods are non-invasive and can provide virtually not delayed and additionally spatially selective information about the combustion process. Additional problems are generated biomass co-firing. The article shows application of relatively new class of classification methods – the artificial immunology algorithms to the combustion process diagnostics consisting in detection of incorrect air excess in PC burner.

Keywords: Artificial Immune Systems, industrial diagnostics, pulverised coal burner

HYBRYDOWY ALGORYTM NEGATYWNEJ SELEKCJI KLONALNEJ DO DIAGNOSTYKI SPALANIA W POJEDYNCZYM PALNIKU PYŁOWYM

Streszczenie. W palnikach pyłowych, które są najbardziej rozpowszechnione w Polsce współczynnik nadmiaru powietrza decyduje o ilości emitowanych zanieczyszczeń, jednak brak metody umożliwiającej pomiar parametrów wyjściowych palnika. Konieczne jest więc stosowanie metod pośrednich, do których można zaliczyć przede wszystkim metody akustyczne i optyczne. Metody te są bezinwazyjne i pozwalają na otrzymanie praktycznie nieopóźnionej i dodatkowo selektywnej przestrzennie informacji o zachodzącym procesie spalania. Dodatkowe problemy powstają przy współspalaniu biomasy. Artykuł przedstawia zastosowanie stosunkowo nowej klasy metod klasyfikacji - sztuczne algorytmy immunologiczne do diagnostyki procesu spalania polegająca na wykrywaniu nieprawidłowej wartości nadmiaru powietrza palnika pyłowego.

Słowa kluczowe: Sztuczne systemy immunologiczne, diagnostyka przemysłowa, palnik pyłowy

Introduction

Power industry and coal based especially has its important share in air pollution. In order to decrease an amount of toxic substances originated in a combustion process the so-called low emissive combustion technology has been introduced. It generally consists in gradual supply of air, in order to create reduction zones in a flame, what reduces emission of gaseous pollutants e.g. like NOx. The main advantage of such modifications is relatively low investment cost. Unfortunately, such technology has some adverse side effects. In order to minimise their consequences it is necessary to obtain information about the course of combustion process as well as its adequate control. Both tasks are relatively difficult because of high complexity of the phenomena proceeding during combustion. Commonly used control systems employ process variables such as: flow of the air-pulverised coal mixture from each mill, air fans load, unit power or emission of gasses (CO, O₂, NOx). There are also successful attempts to replace a classic controller with a neural network one [1, 4]. However, in spite of big complexity, all these systems have one basic disadvantage: the control is based on averaged and heavily delayed measurements. Even the most advanced of recently available control systems is not able to control an individual burner, while an individual air excess ratio rules an amount of pollution generated.

The analysis of the problem let us conclude that there is a lack of method that allows measurement of output parameters of an individual burner like for example air excess level. It is therefore necessary to use indirect methods, which could primarily include acoustic, and optical methods. These methods are non-invasive and can provide virtually not delayed and additionally spatially selective information about the combustion process.

Artificial immunology algorithms are relatively new class of classification methods. This article describes their application to the combustion process diagnostics consisting in detection of incorrect air excess in pulverised coal burner.

1. Artificial immune algorithms

In the 1990s, Artificial Immune System (AIS) emerged as a new computational research field inspired by simulation of biological behavior of Natural Immune System (NIS). The NIS is a very complex biological network with rapid and effective mechanisms for defending the body against a specific foreign body material or pathogenic material called antigen.

During the reactions, the adaptive immune system memorizes the characteristic of the encountered antigen by producing plasma or memory cells. The obtained memory promotes a rapid response of the adaptive immune system to future exposure to the same antigen [8].

In order to respond only to antigen, the immune system distinguishes between what is normal (self) and foreign (non-self or antigen) in the body. The NIS is made up of lymphocytes which are white blood cells circulating throughout the body, mainly of two types, namely B-cells and T-cells. These cells play main role in the process of recognizing and destroying of any antigen [8].

Both T-Cell and B-Cell are created in the bone marrow and they have receptor molecules on their surfaces (the B-cell receptor molecule is also called the antibody). The way B-cells and T-cells identify specific antigen is called a key and key-hole relationship. In this case, antigen and receptor molecule have complementary shapes, therefore they can bind together with a certain binding strength, measured as affinity. After a binding between an antibody's paratope and an antigen's epitope, an antigen-antibody-complex is formed which results in deactivation of the antigen. The B-Cell is already mature after creation in the bone marrow, whereas the T-Cell first becomes mature in the thymus. However a T-Cell becomes mature if and only if it does not have receptors that bind with molecules that represent self cells. Consequently, it is very important that the T-Cell can differentiate between self and non-self cells [8].

The Artificial Immune Systems, as defined by de Castro and Timmis [2] are: "Adaptive systems inspired by theoretical immunology and observed immune functions, principles and models, which are applied to problem solving". However AIS are one of many types of algorithms inspired by biological systems, such as neural networks, evolutionary algorithms and swarm intelligence. There are many different types of algorithms within AIS and research to date has focused primarily on the theories of immune networks, clonal selection and negative selection. These theories have been abstracted into various algorithms and applied to a wide variety of application areas such as anomaly detection, pattern recognition, learning and robotics [3].

1.1. Negative selection algorithm

The negative selection of T-cells is responsible for eliminating the T-cells whose receptors are capable of binding with self-peptides presented by self-MHC molecules. This process guarantees that the T-cells that leave the thymus do not recognize

any self-cell or molecule. Forrest et al. [6] proposed a change detection algorithm inspired by the negative selection of T-cells within the thymus. This procedure was named as negative selection algorithm and was originally applied in computational security. A single type of immune cell was modelled: T-cells were represented as bit strings of length L . The negative selection algorithm of Forrest and collaborators is simple. Given a set of self-peptides, named self-set S , the T-cell receptors will have to be tested for their capability of binding the self-peptides. If a T-cell recognizes a self-peptide – it is discarded, else it is selected as an immune-competent cell and enters the available repertoire A .

The idea of negative selection algorithm is to generate a set of detectors in a complementary set of N and then to use these detectors for binary classification as “Self” or “Non-Self”. Formally, the negative selection algorithm can be represented as [5, 10]:

$$NegAlg = (\Sigma^L, L, S, N, r, n, s, pr) \quad (1)$$

where Σ^L denotes shape-space; L is receptor length; S is “Self” detector set; N is “Non-Self” detector set; r denotes cross-reactive threshold; n is total number of appointed detectors; s is detector set size; pr denotes rule matching rows in adjacent positions.

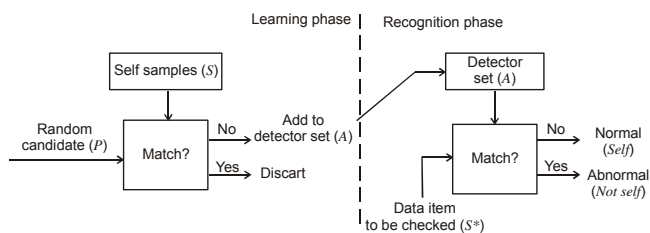

Fig. 1. Negative selection algorithm

The negative selection algorithm can be summarized as follows [10]:

- **Initialization:** randomly generate strings and place them in a set P of immature T-cells, assuming all the molecules (receptors and self-peptides) are represented as binary strings of the same length L .
- **Affinity evaluation:** determine the affinity of all T-cells in V with all elements of the self set S .
- **Generation of the available repertoire:** if the affinity of an immature T-cell with at least one self-peptide is greater than or equal to a give cross reactive threshold, then the T-cell recognizes this self-peptide and has to be eliminated (negative selection); else the T-cell is introduced into the available repertoire A .

The process of generating the available repertoire in the negative selection algorithm was termed learning phase. The algorithm is also composed of a monitoring phase. In the monitoring phase, a set S^* of protected strings is matched against the elements of the available repertoire A . The set S^* might be the own set S , a completely new set, or composed of elements of S . If recognition occurs, then a non-self pattern (string) is detected.

It is well known, that the algorithm of negative selection (NS) has the some restrictions and limitations [2, 8]. When it is not appropriate, for example, the number of self samples is small and sparse.

Some limitations of the binary-string representation in NS algorithms are as follows:

- binary matching rules are not able to capture the semantics of some complex self/non-self spaces,
- it is not easy to extract meaningful domain knowledge,
- in some cases a large number of detectors are needed to guarantee better coverage (detection rate),
- it is difficult to integrate the NS algorithm with other immune algorithms,
- the crisp boundary of “self” and “non-self” may be very hard to define.

In real-valued representation the detectors are represented by hyper-shapes in n -dimensional space. The algorithms use geometrical spaces and use heuristics to distribute detectors in the non-self space.

Some limitations of the real-valued representation in NS algorithms are:

- the issue of holes in some geometrical shapes, and may need multi-shaped detectors,
- curse of dimensionality,
- the estimation of coverage,
- the selection of distance measure.

During our experiments it has been established that generation of set of detectors in at training phase occurs casually owing to what it is in advance impossible to define is minimum necessary quantity of detectors which will provide the maximum quality of recognition. The increase in quantity of detectors conducts to delay of a phase of recognition, and its reduction – to deterioration of work of algorithm since the probability of formation of the "cavities" which are areas in space of “Non-self” which are not distinguished by any of detectors increases. Thus, a problem of the given research is working out of an advanced method of generation of the detectors, capable to adaptive selection of their options, quantity and an arrangement.

1.2. Clonal selection algorithm

Today the algorithm CLONALG exists in two forms [4]: (1) for optimization problems solving, and (2) for solving problems of classification and pattern recognition.

Basic clonal selection algorithm [2], named CLONALG, operates as shown in Fig. 2.

1. Initialization; randomly initialize a repertoire (population) of attribute strings (immune cells).
2. Population loop .for each antigen, do:
 - 2.1. Selection; select those cells whose affinities with the antigen are greater.
 - 2.2. Reproduction and genetic variation: generate copies of the immune cells: the better each cell recognizes the antigen, the more copies are produced. Mutate (perform variations) in each cell inversely proportional to their affinity: the higher the affinity, the smaller the mutation rate.
 - 2.3. Affinity evaluation: evaluate the affinity of each mutated cell with the antigen.
3. Cycle: repeat Step 2 until a given convergence criterion is met.

Fig. 2. Standard clonal selection algorithm

Formally algorithm of clonal selection can be represented as [5]:

$$CLONALG = (P^l, G^k, l, k, m_{Ab}, \delta, f, I, \tau, AG, AB, S, C, M, n, d)$$

where P^l is space of search (space of forms); G_k is space representation; l is the length of vector of attributes (dimension of space of search); k is the length of antibody receptor; m_{Ab} is dimension of population of antibodies; δ is the expression function; f is the affinity function; I is the function of initialization of the initial population of antibodies; τ is the condition of completion of algorithm work; AG is the subset of antigens; AB is population of antibodies; S is the operator of selection; C is the operator of cloning; M is the mutation operator; n is the number of the best antibodies selected for cloning; d is the number of the worst antibodies subjected to substitution for new ones.

The process of converting a population of antibodies by clonal selection algorithm can be represented as a sequence of the following statements:

$$\begin{aligned} AB_t &\xrightarrow{\text{Selection}(S)} G_S \xrightarrow{\text{Cloning}(C)} G_C \\ G_C &\xrightarrow{\text{Mutation}(M)} G_M \xrightarrow{\text{Repeat mutation}(S)} G_S \\ G_S &\xrightarrow{\text{Replacement}(d)} AB_{t+1}, \end{aligned}$$

where t is the number of generation, AB is the population of antibodies (detectors), G_S is the subset of selected best antibodies, G_C is the subset of clones and G_M is the subset of clones after mutation.

1.3. Combined clonal and negative selection algorithm

The second problem is the fact that the negative selection algorithm is intended only to solve the problems of anomaly detection and binary classification. Only a small number of works devoted to the use of negative selection algorithm of multi class classification problems [3, 5, 8]. However, none of these studies have not solved these problems simultaneously. The classifier presented in this paper is based on the hybridization process of negative selection with clonal selection, and was designed to solve problems of classification to many classes. Concept of classification is used in terms of supervised learning, which allows categorizing objects into known groups using training set prepared beforehand. The main task of every classifier based on supervised learning is to create an internal representation of classes (in the form of a function, set of rules or any other). It acquires it during training. When the training is completed the classifier is ready to produce an answer to any (known or unknown) pattern given subsequently.

In this study the efficiency of immune classifiers is researched, when as the classifier, in general, is a function that for attributes vector of object shall decide to which class it belongs [2, 5]:

$$F : \mathcal{R}^n \rightarrow Y$$

The function F represents the space of sign vectors in the space of the class labels Y . In the case of two classes $Y=\{0,1\}$, '1' corresponding to a case of the detection event and '0' the event is not detected. We consider the variant of training with a teacher (supervised learning), when the classifier training available to us a set of vectors $\{x\}$ for which is known their valid membership in one of the classes.

In developing this model treated the problem of developing an improved method of generation of detectors capable to adaptively select their debugging and localization. This modification propose in a phase of training to optimize coverage by detectors set of "Non-self" via the mechanism of clonal selection. For the solution of the problem is introduced following submission of antibodies (Fig.3).

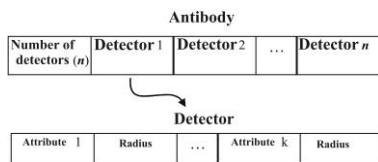

Fig. 3. View of clonal negative model antibody [6]

In this view, attributes are the coordinates of the center of the detector and the radius - the threshold sensitivity of the detector (cross-reactive threshold). Thus, each antibody encodes a possible alternative arrangement of detectors in space "Non-self", that option schemes covering. By manipulating the population of antibody-like structure, is the best option scheme covering.

The proposed Combined Clonal Negative Selection Algorithm for Multi-Class problem classification) consists of ensemble of n elements responsible for assigning patterns to corresponding n classes, as it is presented in Figures 4 and 5.

The procedure of the algorithm is shown in Fig. 6 [7].

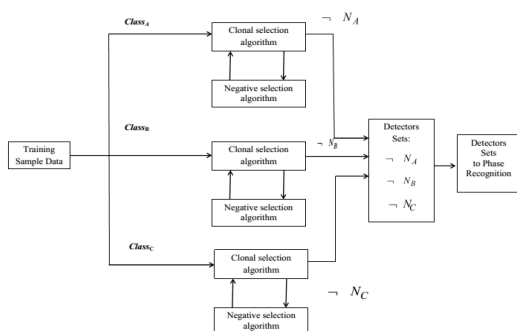

Fig. 4. Multi-class combination of negative clonal selection algorithm (Training phase)

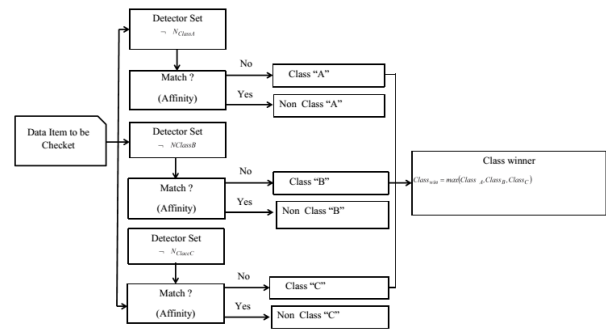

Fig. 5. Multi-class combination of negative clonal selection algorithm (Recognition phase)

- Step 1. Create an initial population of antibodies (detectors)
- Step 2. The transformation of each antibody in the scheme cover. Coverage scheme is a set of antibodies in which the attribute values are the centre and the radius is the boundary value of the sensitivity of the detector, i.e. cross-reactive threshold. Thus, each antibody encodes one possible location of the detectors in the space of "Non-self", one has the option "scheme covering"
- Step 3. Recognition on the learning sample (Negative selection algorithm)
- Step 4. Conversion obtained results of recognition in the numerical values of affinity antibodies (detector). In other words, the percentage of examples which has been recognized correctly.
- Step 5. Stop criteria evaluation: If $C_{tm} - 1 > C_m$ then end, otherwise go to step 6
- Step 6. Ranking detectors (antibodies) in the degree of discrepancy
- Step 7. Selection of those antibodies which are most "not match" (usually 30%)
- Step 8. Cloning of selected antibodies
- Step 9. Mutation of antibodies (greater difference, the smaller the rate of mutation and vice versa)
- Step 10. Conversion of each antibody in all clones in the coating scheme
- Step 11. Recognition on the learning sample (Negative selection algorithm)
- Step 12. Conversion of obtained results of recognition into numerical values of antibodies affinity (detector). In other words, the percentage of examples which has been recognized correctly.
- Step 13. Ranking of detectors (antibodies) in the degree of discrepancy
- Step 14. Selection of those antibodies which do not match the most (usually 30%)

Fig. 6. Block diagram of clonal selection with a modified phase learning method of negative selection

2. Test methodology and facility

Combustion of pulverized coal was examined through optical methods, which were based on analysis of wide spectrum radiation emitted by the flame. The analysis also takes into account spatial features of such radiation source. Combustion of pulverized coal in the power burner takes place in a turbulent flow. In its each point local fluctuations of both fuel and gaseous reagents concentrations, as well as temperature occur. It leads to permanent local changes in combustion process intensity, which result in continuous changes in flame luminosity that can be observed as flame flicker. As combustion process affects the turbulent movement of its products and reagents it determines the way the flame flicker parameters such as e.g. mean luminosity and luminosity frequency spectrum.

A number of combustion supervision and flame-fault protection systems use information contained within flame flicker.

The multichannel fibre-optic flame monitoring system developed at Lublin University of Technology belongs to this class of solutions but additionally it allows observation of selected areas of the flame.

Experiments were made on test rig located in the Institute of Power Engineering in Warsaw. It is a combustion chamber with a single pulverized coal swirl burner made in 1:10 scale in relation to a low-emission industrial burner. This object was chosen because of the ability to perform experiments with a single burner, and it's a good instrumentation. All measured quantities are visualized and recorded by the data acquisition system. Sampling period is 1s. The combustion chamber is equipped with the above mentioned optical fibre probe which allows observation of five different areas of the flame. Figure 7 shows section of part of the chamber with marked areas of view.

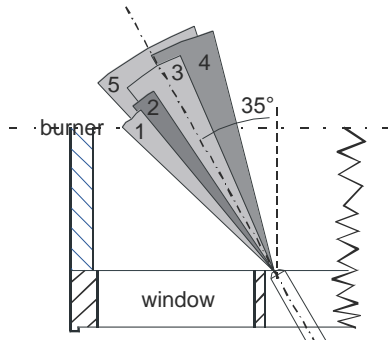

Fig. 7. Areas of view of fibers

3. Measurements

The experiment begins with bringing the chamber to the proper temperature. When the temperature stabilizes the series of measurements are performed with changing air and fuel flows. During an individual measurement the amounts of fuel and air are kept constant. A single measurement lasts approximately 300 seconds. Such a measurement method is to eliminate the impact of the transport delay of gas analysers. It is assumed that during the measurement the conditions are fixed and the emission values stabilized.

The tests were made at three different thermal loads, for pure pulverised coal and 10% blend with biomass (shredded straw). The amount of secondary air was being changed in order to achieve the air excess corresponding to normal operation, too high and too low conditions.

Voltage signals corresponding to the instantaneous brightness of the flame of the areas observed by individual optical fibres were sampled at the rate of 8KS/s and saved by a dedicated system. Figure 8 shows example measurements corresponding to normal, too low and too high air excess ratio.

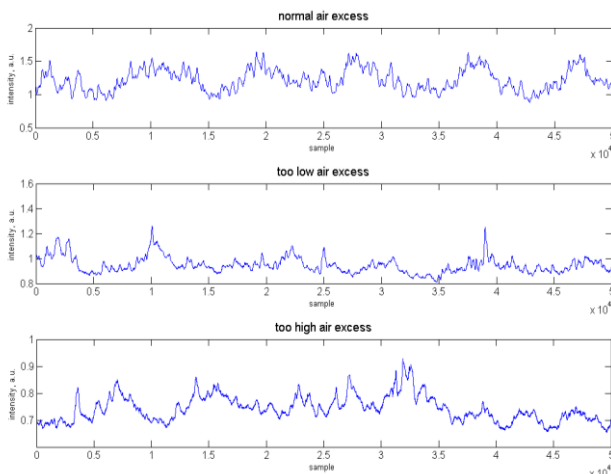

Fig. 8. Example measurements corresponding to normal, too low and too high air excess ratio

Feature extraction was the next step. Selected coefficients of discrete wavelet transform (DWT) [10] of a local signal intensity of the flame radiation were chosen as features of the flame. The negative clonal selection was used as classification algorithm. There are three classes to be recognised so the classifier contained three subsets of detectors (Fig. 9). The measurement data was processed with DWT (Daubechies 6) in the windows of length 16,384 samples. Subsequently, the statistical parameters (maximum value, minimum and average and standard deviation) of the most significant transform coefficients – D1, D2, D3, D4 and A1 were calculated to give the vector of 20 features for each class. A set of features was randomly divided into learning and testing subsets by 30% / 70% and 70% / 30%.

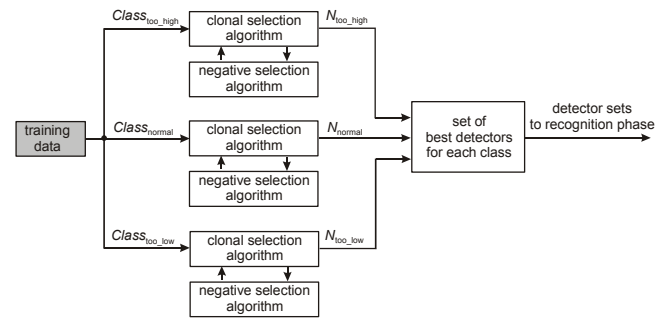

Fig. 9. Synthesis of adaptive binary classifiers – learning phase in negative clonal selection algorithm

In order to avoid the bias associated with the random sampling of the training data the k-fold cross-validation was also performed. In k-fold cross-validation, the data is partitioned into k subsets of approximately equal size. Training and testing the algorithm is performed k times. Each time, one of the k subsets is used as the test set and the other k-1 subsets are put together to form a training set. Thus, k different test results exist for the algorithm. However, these k results are used to estimate performance measures for the classification system. Table 1 contains class distribution of the data points in the training and testing datasets.

Table 1. Class distribution of the data points in the training and testing datasets

Class	Training set	Testing set	Total
λ too high	720	1680	2400
λ correct	720	1680	2400
λ too low	720	1680	2400
Total	2160	5040	7200
λ too high	1680	720	2400
λ correct	1680	720	2400
λ too low	1680	720	2400
Total	5040	2160	7200
λ too high	1920	480	2400
λ correct	1920	480	2400
λ too low	1920	480	2400
Total	5760	1140	7200

The common performance measures used in diagnostics are accuracy, sensitivity and specificity. Accuracy expresses the ability of the classifier to produce accurate diagnosis. The measure of the ability of the model to identify the occurrence of a target class accurately is determined by sensitivity. Specificity is determined the measure of the ability of the algorithm to separate the target class. The accuracy can be expressed as:

$$Accuracy(Z) = \frac{\sum_{i=1}^{|Z|} Assess(z_i)}{|Z|}$$

while

$$Assess(z) = \begin{cases} 1, & \text{if } classify(z) = z.c \\ 0, & \text{otherwise} \end{cases}$$

where z denotes the patterns in testing set to be classified, z.c is the class of pattern z, classify(z) returns the classification of z by

classification algorithm. For sensitivity and specificity analysis, the following equations can be used:

$$\text{Sensitivity} = \frac{TP}{TP + FN}$$

$$\text{Specificity} = \frac{TN}{TN + FP}$$

where TP, TN, FP i FN denote respectively true positive, true negative, false positive and false negative classification.

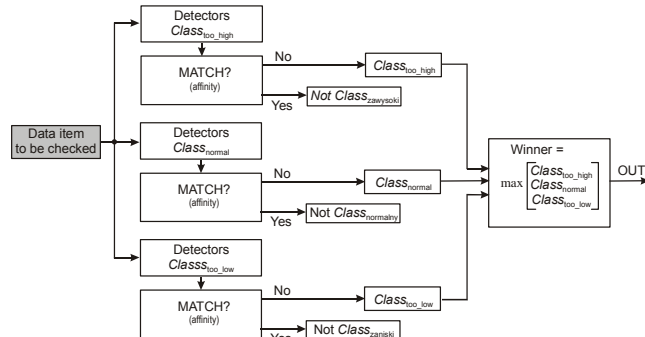

Fig. 10. Classification phase in negative clonal selection algorithm

4. Results

Classification tests using negative clonal selection algorithm were made according to the algorithm shown in Fig 10. Table 2 contains the results of performance analysis. Average accuracy was about 98,99%. Classification accuracy obtained using fuzzy networks (TSK) was about 96,4% [9]. Normalised execution time of both algorithms was similar.

Table 2. Performance measures for negative clonal selection algorithm

learning set/testing set distribution	accuracy	sensitivity	specificity
40/60	98,95	99,25	99,10
60/40	99,18	99,20	99,45
80/20 5-fold cross-validation	98,85	98,75	99,25
mean	98,99	99,07	99,27

5. Conclusions

The modified negative selection procedure that uses optimization as well as the artificial immune network for optimization parameters detectors are developed. A distinctive feature of this procedure is a modification of the learning process, through which is implemented to adaptive selection settings, the number and location of detectors.

A distinctive feature of this procedure is a modification of the learning process, due to which is implemented the adaptive selection settings, the number and location of detectors. Experimental studies have shown high efficiency of the proposed procedure, which is evident in its stability through adaptive value of cross-reactive threshold; optimality due to the adaptive immune network configuration size, i.e. the number of required detectors; accuracy by reducing the number and size created "cavities".

Classification accuracy of the negative clonal selection algorithm was better than one of fuzzy (TSK) algorithm when applied to the problem of detection of anomalies in air excess ratio using optical system. Considering similar computational complexity of above mentioned algorithms the advantage of the former one is clear. The negative clonal selection algorithm can then be used for diagnostics of correct cofiring of pulverised coal blends with biomass in individual PC burner.

References

- [1] Arabas J., Białobrzeski L., Chomiak L., Domański T., Świrski K., Neelakantan R.: Pulverized Coal Fired Boiler Optimization and NOx Control using Neural Networks and Fuzzy Logic, Proc AspenWorld'97, Boston, Massachusetts, 1997.
- [2] De Castro L. N., Timmis J. I.: Artificial Immune Systems as a Novel Soft Computing Paradigm, vol. 7, 2003, Soft Computing Journal, vol 7, 2003, pp. 526-544.
- [3] Forrest S.: Self-Nonself Discrimination in a Computer, w Proc. of the 1994 IEEE Symposium on Research in Security and Privacy, Los Almitos, CA:IEEE Computer Society Press, Los Almitos, CA, USA, 1994.
- [4] Kalogiru, S. A.: Artificial intelligence for the modelling and control of combustion processes: a review, Progr Energy Comb Sci, 29, 2003, 515-566.
- [5] Lytvynenko V. I.: Comparative experimental study of a modified negative selection algorithm and clonal selection algorithm negative for solving classification (in Russian), Vestnik Kherson National Technical University, nr 4(33), 2008, pp. 7-14.
- [6] Lytvynenko V. I.: Immune classifier for solving binary classification - Theoretical Aspects (in Russian), System technologies, nr 1(42), 2006, pp. 32-47.
- [7] Lytvynenko V., Smolarz A., Kozhuhivska O.: Combined Clonal Negative Selection Algorithm for Multi-Class problem classification/ Proceedings of the VIIIth Scientific and Technical Conference CSIT, 2013, Lviv , p.163-165.
- [8] Roitt I.M., Delves P.J.: Encyclopedia of Immunology, 2nd ed., Academic Press, London, 1998.
- [9] Smolarz A., Wójcik W., Gromaszek K.: Fuzzy modeling for optical sensor for diagnostics of pulverized coal burner, Procedia Engineering - 2012, vol. 47, pp. 1029-1032.
- [10] Wójcik W., Kotyra A., Smolarz A., Wojciechowski C.: Application of wavelet transformation for analysis of measurements in fibre optic flame monitoring system, Proceedings of SPIE, tom 4239, 2000, pp. 96-101.

Ph.D. Andrzej Smolarz
e-mail: a.smolarz@pollub.pl

Assistant professor in Institute of Electronics and Information Technologies at Lublin University of Technology. Research field covers wide variety of optical methods in industrial diagnostics and control as well as applications of artificial intelligence methods in industrial diagnostics. Author of nearly 100 publications in this research area.



D.Sc. Wołodmyr Lytvynenko
e-mail: immun56@gmail.com

Kherson National Technical University. DSc (Eng. hab.), Professor, Head of the Department Informatics & Computer Sciences. Research interests: artificial immune systems, time series forecasting, multifractal analysis, reinforcement learning..



Ph.D. Olga Kozhuhovskaya
e-mail: olga-kozhuhovska@mail.ru

Ph.D., Senior Lecturer, Department of Computer Systems Cherkasy State Technological University. Research interests: mathematical modelling and computational methods, information technologies based on Bayesian methods, soft computing, reinforcement learning.



Ph.D. Konrad Gromaszek
e-mail: k.gromaszek@pollub.pl

Assistant professor in Institute of Electronics and Information Technologies at Lublin University of Technology. IEEE member. Research interests: hierarchical and adaptive control algorithms, computer networks, ICT systems, digital signal processing, PACs, DAQs, databases and data mining.

