

See discussions, stats, and author profiles for this publication at: <https://www.researchgate.net/publication/331192570>

Affine projection algorithm based decision fusion for cooperative spectrum sensing in cognitive radio networks

Article in *Journal of Theoretical and Applied Information Technology* · January 2019

CITATIONS

0

READS

52

2 authors:



Ali Jamoos

Al-Quds University

36 PUBLICATIONS 119 CITATIONS

SEE PROFILE



Luay Ayyash

college of agricultural

7 PUBLICATIONS 281 CITATIONS

SEE PROFILE

Some of the authors of this publication are also working on these related projects:



Expanding Mobile Network Spectrum with Cognitive Radios [View project](#)



Energy Detection in Cognitive Radio Networks [View project](#)

AFFINE PROJECTION ALGORITHM BASED DECISION FUSION FOR COOPERATIVE SPECTRUM SENSING IN COGNITIVE RADIO NETWORKS

¹ALI JAMOOS, ²LAMA AYYASH

^{1,2}Department of Electronic and Communication Engineering, Al-Quds University, *Jerusalem, Palestine*

E-mail: ¹ai.jamoos@staff.alquds.edu, ²lama.aiash00@gmail.com

ABSTRACT

Spectrum sensing is a main function in cognitive radio networks to detect the spectrum holes or unused spectrum. Cooperative spectrum sensing schemes are recently suggested and they provide fast and accurate results. In this paper, we suggested a new adaptive and cooperative spectrum sensing technique based on the affine projection algorithm (APA). In this method, each secondary user (SU) takes a binary decision by its local sensing of the spectrum using energy detector. Local decisions are then forward to the fusion center (FC), where definitive decision is taken on the status of the spectrum using adaptive filters. In our suggested technique, APA updates the weights of the adaptive filter by using the current and the $L - 1$ delayed input signal vectors. Simulation results indicate that the suggested approach provides faster convergence speed and less steady state mean square error than the existing methods that are based on the normalized least mean square (NLMS) or the so-called kernel least mean square (KLMS) algorithm.

Keywords: *Cooperative spectrum sensing, decision fusion, adaptive filters, APA algorithm, cognitive radio networks.*

1. INTRODUCTION

The growing of need to the wireless applications has caused lots of restrictions on the utilization of radio frequency spectrum, especially it is finite and expensive natural resource. So, the spectrum crowding is now becoming a grave issue [1]. A report by the Federal communications commission (FCC) showed significantly unbalanced usage of spectrum [2]. Indeed, some frequency bands are largely unoccupied most of the time; some other frequency bands are only partially occupied; the remaining frequency bands are heavily used. To enhance the efficiency of the available spectrum, cognitive radio (CR) has been proposed as a novel mode of wireless communication where a transceiver can smartly reveal which communication channels are utilized and which are not, and immediately leave into unoccupied channels while avoiding busy ones [3][4][5]. Spectrum sensing in cognitive radio (CR) is a basic requirement to protect the primary user (PU) from band interference [6][7]. Spectrum sensing methods can be traditionally categorized in three types: energy detection, matched filter detection and cyclostationary feature detection [8][9]. Matched filter detection, as an ideal way for signal detection,

don't need much time to sense the spectrum but it demands a priori knowledge of the properties of the primary user (PU) signal. On the other hand, cyclostationary detection is complicated and needs to know the periodic frequencies of the primary signals, which is not an easy task for many applications. Based on previous studies, energy detection scheme is widely used in CR networks to detect the primary user (PU) signal without any prior knowledge. Energy detector is characterized by low computational complexity and implementation [10]. Spectrum sensing is usually affected by shadowing and time-varying fading in wireless channel. Indeed, remote sensing performance may be affected and the hidden terminal problem. To overcome this effect and to improve the sensing efficiency, cooperative spectrum sensing has been suggested.

In a cooperative spectrum sensing method, each secondary user (SU) executes local energy detection individually and transfers the decision results to the fusion center (FC) for more processing. The final decision on the presence or absence of the PU is then taken at the FC based on collected results from different cognitive radio users [11].

In the literature of cooperative spectrum sensing, the performance of the energy detection is usually verified by using fusion center schemes. There are three classic fusion strategies for decision fusion at the FC. Particularly, the OR rule, the AND rule and the Majority rule that can be within the k -out-of- n rule [12][13]. However, it appears that the combination of rigid local decisions from cognitive stations is not optimum while the sensors are localized under various environmental circumstances. For this reason, a trust level can be set for each secondary user regarding the date of its decision and will be involved into consideration in the data fusion stage. This modern parameter must mirror fluctuating operating conditions, efficiency and reliability of SU detection.

Therefore, specific weights per the SU decision must be defined. To estimate these weights, a cooperative spectrum sensing method based on the normalized least mean square (NLMS) algorithm and recursive least square (RLS) algorithm was proposed in [14]. These adaptive algorithms are shown to improve the detection performance over the conventional decision fusion techniques (OR, AND, majority rules). The RLS algorithm is shown to provide the best performance in-terms of the convergence speed and the steady state least mean square error at the price of increased computational complexity as compared with the NLMS. In [15], the authors proposed a cooperative spectrum sensing technique based on the so-called kernel least mean square (KLMS). It is shown that the KLMS can increase the accuracy of decisions over the LMS, but inferior performance when compared with the RLS.

In this paper, a novel adaptive and cooperative spectrum sensing methods is suggested based on the affine projection algorithm (APA). APA can be considered as a generalization of the NLMS. In fact, while the NLMS update the adaptive weights by using the existing vector, APA updates the adaptive weights by using the existing and the $L-1$ delayed input signal vectors.

This paper is organized as follows. In section II, the decision fusion model is presented. In section III, the adaptive algorithms to estimate the SUs confidence level are introduced. The simulation results are presented in section IV. Conclusion remarks are drawn in section V.

2. DECISION FUSION MODEL

Spectrum sensing is a key element in cognitive radio networks that allows the SU to detect the unused spectrum belonging to the primary system. The SU can then significantly utilize the unused frequency bands without causing interference to the primary system [16][17]. In this section, the decision fusion system model for cooperative spectrum sensing is introduced.

Spectrum sensing may be seen as a binary hypothesis testing problem as follows:

$$\begin{cases} H_1 : \text{The signal is present} \\ H_0 : \text{The signal is absent} \end{cases} \quad (1)$$

The received signal $y(t)$ from time-varying flat-fading channel can be interpreted as a binary hypothesis test as follows:

$$y(t) = \begin{cases} n(t), & H_0 \\ h(t)x(t) + n(t), & H_1 \end{cases} \quad (2)$$

where $n(t)$ is an additive white Gaussian noise (AWGN) process with one-sided power spectral density N_0 Watt/Hz, $s(t)$ is the transmitted signal, and $h(n)$ is the time-varying fading channel. On the one hand, hypothesis H_0 expresses the absence of primary signal so that the received signal $y(t)$ consists of just the AWGN process $n(t)$. On the other hand, hypothesis H_1 expresses the existence of primary signal so that $y(t) = h(t)x(t) + n(t)$. Consider a cooperative spectrum sensing system with K secondary users which are assume to be statistically independent. Every cognitive SU terminal performs a local sensing to make a local decision $d_i, i = 1, 2, \dots, K$, where

$$d_i = \begin{cases} +1 & \text{if } H_1 \text{ is true} \\ -1 & \text{if } H_0 \text{ is true} \end{cases} \quad (3)$$

The comprehensive decision d_c at the FC is then computed as shown in Fig. 1, where w is a confidence level that is affected by each secondary user. The probability of detection P_D and the probability of false alarm P_F should be known [18], and they can be described as follow:

$$P_D = P_r(Y > \lambda | H_1) \quad (4)$$

$$P_F = P_r(Y > \lambda | H_0) \quad (5)$$

where λ is known as threshold value, and Y is the decision metric.

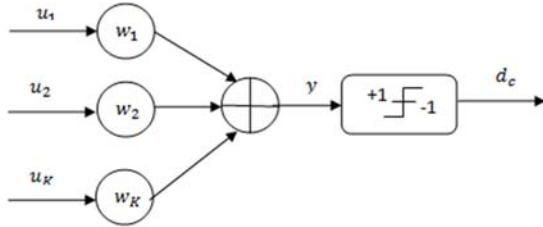

Fig.1: Fusion center architecture [14].

3. ADAPTIVE WEIGHTS ESTIMATION

The adaptive weights estimation scheme for cooperative spectrum sensing is shown in Fig. 2.

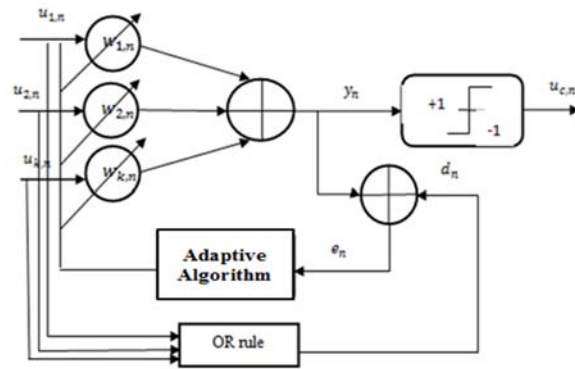

Fig.2: Adaptive Weights Estimation Process.

To estimate adaptively the SUs weights, the system receives at each time instant n an input vector $\mathbf{u}(n)=[u_{1,n} \dots u_{K,n}]^T$ that represent all SU decisions and a desired response $\hat{d}(n)$. The input vector components of local decisions are weighed by the corresponding adaptive coefficients representing the SUs decisions confidence levels, given by $\mathbf{w}(n)=[w_{1,n} \dots w_{K,n}]^T$. Thus, the output of the adaptive linear combiner $y(n)$ can be expressed as:

$$y(n) = \mathbf{w}^T(n)\mathbf{u}(n) \quad (6)$$

The updating error is

$$e(n) = \hat{d}(n) - y(n) \quad (7)$$

The reference decision $\hat{d}(n)$ can be obtained by combining the local decisions from the various SUs using the conventional cooperative spectrum

sensing technique (AND, OR, Majority) [11]. In this paper, the OR rule is used to generate the reference signal $\hat{d}(n)$ due to its high detection probability and low complexity.

In the following, the weights of the adaptive linear combiner are updated by using several adaptive algorithms.

A. Normalized Least Mean Square (NLMS) Algorithm

The least mean square (LMS) algorithm is an adaptive implementation of the mean square error (MSE) solution [20]. The weights are updated with a correction proportional to the input vector $\mathbf{u}(n)$ as follows:

$$\mathbf{w}(n+1) = \mathbf{w}(n) + \mu_{LMS}e(n)\mathbf{u}(n) \quad (8)$$

where μ_{LMS} is the LMS step size. The LMS algorithm is sensitive to scaling the input vector and may lead to gradient noise amplification problem. This makes it very hard to guarantee the stability of the algorithm. For this reason, a regularized normalized version of the LMS algorithm is usually employed [21]. This is done by normalizing the step size by the power of the input signal. Thus, the update equation of the normalized least mean square (NLMS) algorithm is given by:

$$\mathbf{w}(n+1) = \mathbf{w}(n) + \frac{\mu_{NLMS}}{\mathbf{u}^T(n)\mathbf{u}(n)}e(n)\mathbf{u}(n) \quad (9)$$

where μ_{NLMS} is the NLMS step size.

B. Kernel Least Mean Square (KLMS) Algorithm

The KLMS is known to perform well in estimating a complex nonlinear mapping in an online manner. Thus, this method can track the changing environments and enhance the reliability of decisions in FC [15][22].

The KLMS is an adaptive kernel-based algorithm introduced in reproducing Kernel Hilbert space (RKHS). The benefit of kernel-based filters in RKHS is the employment of the linear structure of this space to implement well-established linear adaptive algorithms. The kernel-induced mapping is employed to transform the input $\mathbf{u}(n)$ into a high-dimensional feature space as $\boldsymbol{\varphi}(\mathbf{u}(n))$. The system output of the KLMS is denoted by $\mathbf{w}^T(n)\boldsymbol{\varphi}(\mathbf{u}(n))$. Therefore, evaluating $\mathbf{w}^T(n)$ through stochastic gradient descent may prove as an effective way of nonlinear filtering as LMS does

for linear problems. Given the feature space $\boldsymbol{\varphi}(\mathbf{u}(n))$, the LMS algorithm can be re-written as follows:

$$\begin{aligned} \mathbf{w}(0) &= 0 \\ e(n) &= \hat{d}(n) - \mathbf{w}^T(n-1)\boldsymbol{\varphi}(\mathbf{u}(n)) \quad (10) \\ \mathbf{w}(n) &= \mathbf{w}(n-1) + \mu_{KLMS}e(n)\boldsymbol{\varphi}(\mathbf{u}(n)) \end{aligned}$$

where $\mathbf{w}(n)$ is the new estimated weight vector in high-dimensional feature space and μ_{KLMS} is the KLMS step size.

Going through the iterations of (10), the weight update can be expressed as:

$$\begin{aligned} \mathbf{w}(n) &= \mathbf{w}(n-1) + \mu_{KLMS}e(n)\boldsymbol{\varphi}(\mathbf{u}(n)) \\ &= \mu_{KLMS} \sum_{j=1}^n e(j) \boldsymbol{\varphi}(\mathbf{u}(j)) \quad (11) \end{aligned}$$

The system output to a new input \mathbf{u}_* can only be expressed as an inner products between transformed inputs as follows:

$$\begin{aligned} \mathbf{w}^T(n)\boldsymbol{\varphi}(\mathbf{u}_*) &= \mu_{KLMS} \left(\sum_{j=1}^n e(j) \boldsymbol{\varphi}(\mathbf{u}(j))^T \right) \boldsymbol{\varphi}(\mathbf{u}_*) \\ &= \mu_{KLMS} \sum_{j=1}^n e(j) (\boldsymbol{\varphi}(\mathbf{u}(j))^T \boldsymbol{\varphi}(\mathbf{u}_*)) \quad (12) \end{aligned}$$

By kernel trick filter output valuation, the filter output can be written as:

$$\mathbf{w}^T(n)\boldsymbol{\varphi}(\mathbf{u}_*) = \mu_{KLMS} \sum_{j=1}^n e(j) \kappa(\mathbf{u}(j), \mathbf{u}_*) \quad (13)$$

Thus, the KLMS filter can be implemented sequentially as follows:

$$\begin{aligned} y(n) &= \mathbf{w}^T(n)\boldsymbol{\varphi}(\mathbf{u}(n)) \\ &= \mu_{KLMS} \sum_{j=1}^{n-1} e(i-1) \kappa(\mathbf{u}(j), \mathbf{u}(i)) \quad (14) \end{aligned}$$

where $\kappa(\mathbf{u}(j), \mathbf{u}(i))$ is the Gaussian kernel:

$$\kappa(\mathbf{u}(j), \mathbf{u}(i)) = \frac{1}{\sqrt{2\pi}\sigma} \exp\left(-\frac{\|\mathbf{u}(j)-\mathbf{u}(i)\|^2}{2\sigma^2}\right) \quad (15)$$

with σ is the kernel size.

C. Affine Projection Algorithm (APA)

APA can be considered as a generalization of the NLMS. In fact, while the NLMS update the adaptive weights by using the current input vector, APA updates the adaptive weights by using the current input vector and the late $L-1$ delayed input vectors $\mathbf{u}(n), \mathbf{u}(n-1), \dots, \mathbf{u}(n-L+1)$ [23][24][25]. To this end, let us define the

following input matrix $\mathbf{U}(n)$, decision vector $\mathbf{d}(n)$ and error vector:

$$\mathbf{U}^T(n) = [\mathbf{u}(n) \mathbf{u}(n-1) \dots \mathbf{u}(n-L+1)] \quad (16)$$

$$\mathbf{d}(n) = [\hat{d}(n) \hat{d}(n-1) \dots \hat{d}(n-L+1)]^T \quad (17)$$

$$\mathbf{e}(n) = \mathbf{d}(n) - \mathbf{U}(n)\mathbf{w}(n) \quad (18)$$

Then, the weights of the APA can be updated as follows:

$$\mathbf{w}(n+1) = \mathbf{w}(n) + \mu_{APA} \mathbf{U}^T(n) (\mathbf{U}(n)\mathbf{U}^T(n))^{-1} \mathbf{e}(n) \quad (19)$$

where μ_{APA} is the APA step size. It should be noted that the APA can approximate the RLS algorithm when the block size L approaches the length of the filter.

D. Recursive Least Squares (RLS) algorithm

The recursive least square (RLS) algorithm is obtained by minimizing the weighted least square error cost function [26][27]:

$$J_{\mathbf{w}}(n) = \sum_{i=0}^n \lambda^{n-i} e^2(n) \quad (20)$$

where $0 < \lambda < 1$ is the exponential forgetting factor which helps provide a tradeoff between the algorithm tracking capability and steady state performance. If no forgetting factor is needed, we choose $\lambda = 1$.

The RLS algorithm results after minimizing the cost function in (19), i.e. solving the following equation:

$$\nabla_{\mathbf{w}} J_{\mathbf{w}}(n)|_{\mathbf{w}=\mathbf{w}_n} = 0 \quad (21)$$

The RLS algorithm operates in three steps at each recursion:

$$\mathbf{k}(n+1) = \frac{\mathbf{P}(n)\mathbf{u}(n+1)}{\lambda + \mathbf{u}^T(n+1)\mathbf{P}(n)\mathbf{u}(n+1)} \quad (22)$$

$$\begin{aligned} \mathbf{w}(n+1) &= \mathbf{w}(n) + \\ &\mathbf{k}(n+1)(\hat{d}(n+1) - \mathbf{w}^T(n)\mathbf{u}(n+1)) \quad (23) \end{aligned}$$

$$\mathbf{P}(n+1) = \lambda^{-1}(\mathbf{P}(n) - \mathbf{k}(n+1)\mathbf{u}^T(n+1)\mathbf{P}(n)) \quad (24)$$

with initial value $\mathbf{P}(0) = \delta \mathbf{I}$, where δ is a small positive constant and \mathbf{I} is the identity matrix.

4. SIMULATION RESULTS

A centralized wireless network with K secondary cognitive radio users were considered. The network performance is measured in-terms of mean square error (MSE), probability of detection (Q_d), probability of false alarm (Q_f), and receiver operating characteristic (ROC). Different parameters are considered such as signal-to-noise ratio (SNR), L in APA, convergence speed and computational complexity. Spectrum sensor is implemented using energy detection, where all decisions thresholds are matched to each SU. The learning curves for the proposed APA algorithm is demonstrated and compared with other adaptive algorithms such as LMS, NLMS, KLMS and RLS. This test is based on Monte Carlo simulations.

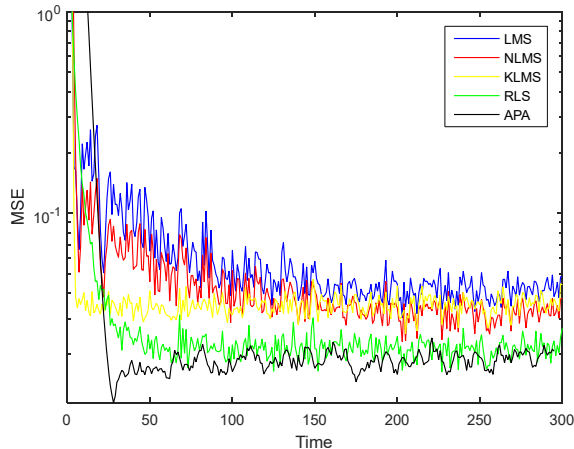

Fig.3. Learning curves of APA and other four algorithm LMS, NLMS, KLMS, and RLS.

Fig. 3 clarify the learning curve for the APA algorithm as compared with LMS, NLMS, KLMS, and RLS algorithms. Here we have 10 users, with SNR=10dB each and the learning step-size are $\mu_{LMS} = 0.1$, $\mu_{NLMS} = 0.7$, $\mu_{KLMS} = 0.2$, $\mu_{APA} = \frac{1}{L}$ ($L = 2$), and $\delta_{RLS} = 0.99$. The probability of pafalse alarm is set to $P_f = 0.1$.

According to Fig. 3 and Table 1, the propose APA algorithm provides faster convergence speed and less steady state mean square error than the LMS, KLMS, and NLMS. Also, it yields a trade-off between detection performance and computational complexity when compared with the RLS.

Fig. 4 shows effect the different value of L on the performance of the APA algorithm when SNR=5dB. We notice that increasing the value of L will results in faster converges speed.

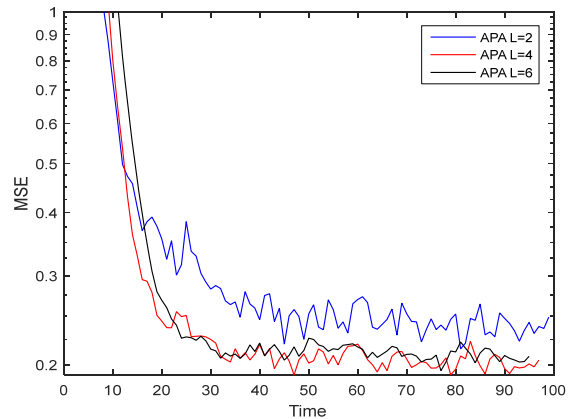

Fig.4. Learning curve of APA for different value of L .

The computational complexity of the various adaptive algorithms is shown in Table 1. It is clear that the RLS has the highest computational complexity and the LMS has the lowest complexity, while the APA has the moderate complexity that varies with L .

Table1: Computational complexity of various algorithms.

Algorithm	Computational Complexity
LMS	$O(K)$
KLMS	$O(nK)$
APA	$O(KL^2)$
RLS	$O(K^2)$

To estimate the efficiency and reliability, we need to figure out the probability of detection and probability of false alarm Q_d, Q_f . Fig. 5, demonstrated the performance of the proposed APA algorithm as compared with other algorithms. We consider three decision fusion rules (OR, AND, MAGERITY rules), and adaptive filters algorithms (LMS, NLMS, KLMS, RLS). According to Fig. 5, the proposed APA is performing better than LMS, NLMS, and KLMS algorithms. Also, it provides a trade-off between detection performance and computational complexity when compared with the RLS.

Fig. 6 shows the probability of false alarm with different SNR for different decision fusion scheme and adaptive filters that have been mentioned. On can notice that the proposed APA algorithm and the RLS result in less Q_f than the other technique especially at low SNR. Thus we suggest using the proposed APA at low SNR.

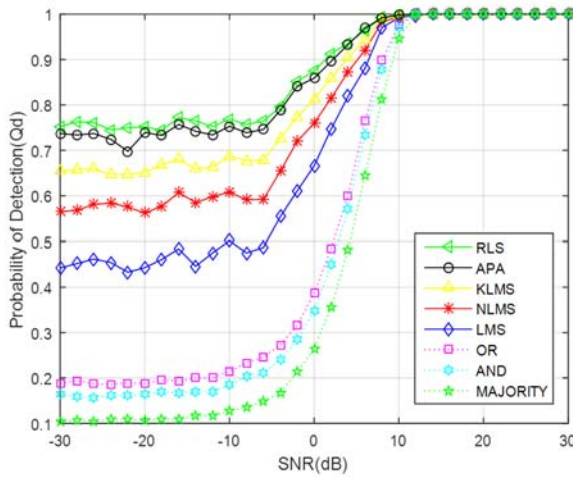

Fig. 5. Probability of detection for the various adaptive algorithms.

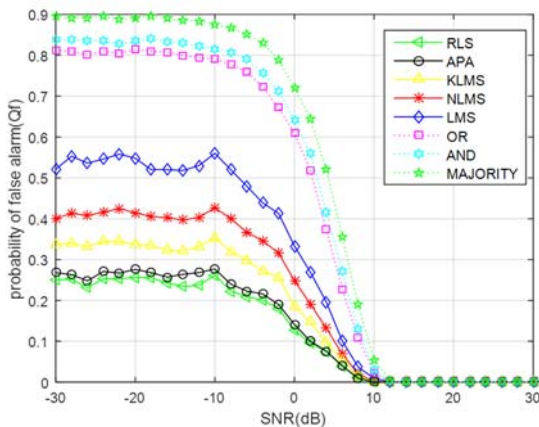

Fig. 6. Probability of false alarm for the various adaptive algorithms.

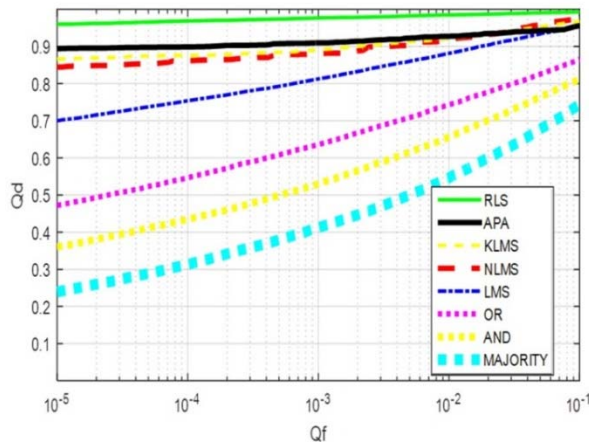

Fig.7. Receiver operating characteristics (ROC) curves.

The receiver operating characteristic (ROC) curve is created by plotting the probability of detection (Q_d) against the probability of false alarm (Q_f) at various threshold settings.

As shown in Fig.7. Different fusion rules and adaptive algorithms are considered. It is clear that the proposed APA algorithm has better performance than LMS, NLMS and KLMS and the other fusion rules.

5. CONCLUSION

In this paper, the affine projection algorithm (APA) is suggested for cooperative spectrum sensing in cognitive radio networks. This algorithm is a generalization for the NLMS algorithm to $L - 1$ delayed input signal vectors. It was shown through simulation results that the suggested method can considerably enhance the reliability of decisions in the FC over the existing KLMS based technique. Indeed, it provides faster convergence speed and less steady state mean square error than the LMS, KLMS, and NLMS. Also, it provides a trade-off between detection performance and computational complexity when compared with the RLS.

REFERENCES

- [1] Lamiaa Khalid, “Efficient Techniques for Cooperative Spectrum Sensing in Cognitive Radio Networks”, PhD thesis, Toronto, Canada, 2014.
- [2] Federal Communication Commission (FCC), “Spectrum policy task force report, ET Docket No. 02-155,” Technical Report Series, November 2002.
- [3] J. Mitola and G. Maguire, “Cognitive radio: making software radios more personal,” IEEE Personal Communications, vol. 6, no. 4, pp.13-18, August 1999.
- [4] S. Haykin, “Cognitive radio: brain-empowered wireless communications,” IEEE Journal on Selected Areas in Communications, vol. 23, no. 2, pp. 201–220, February 2005.
- [5] I. F. Akyildiz, W. Y. Lee, M. C. Vuran, and S. Mohanty, “Next generation / dynamic spectrum access/ cognitive radio wireless networks: A survey,” Computer Networks Journal, Vol. 50, No. 13, pp. 2127–2159, September 2006.
- [6] Ramzi Saifan, Iyad Jafar, Ghazi Al Sukkar, “Optimized Cooperative Spectrum Sensing Algorithms in Cognitive Radio Networks”, The Computer Journal, Vol.60, No.6, 1 June 2017.

- [7] Risheek Kumar, "Analysis of Spectrum Sensing Techniques in Cognitive Radio", International Journal of Information and Computation Technology, vol. 4, no. 4, pp. 437-444, 2014.
- [8] Dipak P.Patill, Vijay M.Wadhai, "Performance Evaluation Of Different Spectrum Sensing Techniques For Realistic Implementation Oriented Model In Cognitive Radio Networks", International Journal of Wireless & Mobile Networks, vol. 6, no. 6, December 2014.
- [9] H. Darawsheh and A. Jamoos, "Performance Analysis of Energy Detector Over α - μ Fading Channels With Selection Combining", Wireless Personal Communications, Springer, vol. 77, issue 2, pp. 1507-1517, July 2014.
- [10] Pawan Yadav, Rita Mahajan, "energy Detection for Spectrum Sensing In Cognitive Radio Using Simulink", International Journal of Advanced Research in Electrical, Electronics and Instrumentation Engineering, vol. 3, 2014.
- [11] I. F. Akyildiz, B. F. Lo, and R. Balakrishnan, "Cooperative spectrum sensing in cognitive radio networks: a survey," Physical Communication, vol. 4, pp. 40–62, 2011.
- [12] Nikhil Arora, Rita Mahajan, "cooperative Spectrum Sensing Using Hard Decision Fusion Scheme", International Journal of Engineering Research and General Science, Vol.2, Issue 4, June-July, 2014.
- [13] G. Loganathan, G. Padmavathi, S. Shanmugavel, "An efficient adaptive fusion scheme for cooperative spectrum sensing in cognitive radios over fading channels", in proceedings of the IEEE International Conference on Information Communication and Embedded Systems(ICICES2014), India, February 2014.
- [14] Imen NASR, Sofiane CHERIF, "A Novel Adaptive Fusion Scheme For Cooperative Spectrum Sensing", in proceedings of the IEEE Vehicular Technology Conference (VTC Fall), Canada, September 2012.
- [15] Xiguang Xu, Hua Qu, Jihong Zhao, Badong Chen, "Cooperative Spectrum Sensing in Cognitive Radio Networks with Kernel Least Mean Square", in proceedings of the IEEE International Conference on Information Science and Technology, China, April 2015.
- [16] Mohammed Abdo-Tuko, "Performance Evaluation and Comparison of Different Transmitter Detection Techniques for Application in Cognitive Radio", International Journal of Networks and Communications, 2015.
- [17] Mansi Subhedar, Gajanan Birajdar, "Spectrum Sensing Techniques In Cognitive Radio Networks: A survey", International Journal of Next-Generation Networks (IJNGN) Vol.3, No.2, June 2011.
- [18] Tevfik Yucek, Huseyin Arslan, "A survey of Spectrum Sensing Algorithm for Cognitive Radio Applications", IEEE communications Surveys and Tutorials, Vol.11, No.1, 2009.
- [19] Francisco C. Ribeiro Jr., Marcello L. R. de Campos, Stefan Werner, "Distributed Cooperative Spectrum Sensing with Selective Updating", 20th European Signal Processing Conference (EUSIPCO 2012), Bucharest, Romania, August 27 - 31, 2012.
- [20] Shubhra Dixit, Deepak Nagaria, "LMS Adaptive Filters for Noise Cancellation: A Review", International Journal of Electrical and Computer Engineering (IJECE), Vol. 7, No. 5, October 2017.
- [21] Rachana Nagal, Pradeep Kumar, and Poonam Bansal, "A Survey with Emphasis on Adaptive filter, Structure, LMS and NLMS Adaptive Algorithm for Adaptive Noise Cancellation System", Journal of Engineering Science and Technology Review, 12 March 2017.
- [22] W. Liu, J. C. Principe, and S. Haykin, "Kernel adaptive filtering, John Wiley sons," Inc., 2010.
- [23] S. G. Sankaran and A. A. (Louis) Beex, "Convergence behavior of affine projection algorithms," IEEE Trans. Signal Processing, vol. 48, no. 4, pp. 1086–1096, April 2000.
- [24] A. Jamoos, E. Grivel and M. Najim, "Designing Adaptive Filters-Based MMSE Receivers for Asynchronous Multicarrier DS-CDMA Systems", In Proceedings of the IEEE PIMRC, Barcelona, September 2004.
- [25] A. Jamoos, Eric Grivel and Mohamed Najim, "Blind Adaptive Multi-User Detection for Multi-Carrier DS-CDMA Systems in Frequency Selective Fading Channels," in proceedings IEEE ICASSP'05, pp. 925-928, Philadelphia, USA, March 18-23, 2005.
- [26] Jyoti Dhimani, Shadab Ahmad, Kuldeep ulia, "Comparison between Adaptive filter Algorithms (LMS, NLMS and RLS)", International Journal of Science, Engineering and Technology Research (IJSETR) Vol. 2, Issue 5, May 2013.
- [27] D. J. ylavsky and G.R.L. Sohie, "Generalization of the matrix inversion lemma", Proceedings of the IEEE, vol.74, no.7, pp. 1050- 1052, July, 1986.