

Deanship of Graduate Studies

Al-Quds University



**Estimation of Autoregressive Time-Varying Fading
Channels: Application to OFDM Systems**

Ahmad Z. Abdo

M.Sc. Thesis

Jerusalem / Palestine

May, 2008

Deanship of Graduate Studies

Al-Quds University



**Estimation of Autoregressive Time-Varying Fading
Channels: Application to OFDM Systems**

Ahmad Z. Abdo

M.Sc. Thesis

Jerusalem / Palestine

May, 2008

**Estimation of Autoregressive Time-Varying Fading
Channels: Application to OFDM Systems**

By

Ahmad Z. Abdo

**B.Sc.: Electronics Engineering, Al-Quds University,
Palestine**

Supervisor: Dr. Hanna Abdel Nour

Co-supervisor: Dr. Ali Jamoos

**A thesis submitted in partial fulfillment of the
requirements for the degree of Master of Electronic and
Computer Engineering, Faculty of Engineering.**

Al-Quds University

May, 2008

Electronic and Computer Engineering Master Program
Faculty of Engineering
Al-Quds University



Thesis Approval

**Estimation of Auto regressive Time-varying Fading Channels:
Application to OFDM Systems**

By

Student Name: Ahmad Zuhier Abdo

Reg. No: 20411250

Supervisor: Dr. Hanna Abdel Nour

Co-Supervisor: Dr. Ali Jamoos

Master thesis submitted and accepted, Date: -----

The names and signatures of the examining committee members are as follows:

1-.....: Head of Committee Signature

2-.....: Internal Examiner Signature

3-.....: External Examiner Signature

Al-Quds University

May, 2008

Dedication

*I dedicate this work to my parents,
my wife Razan,
my daughter Saheer,
my brothers, sisters, and their families*

Declaration

I Certify that this thesis submitted for the degree of Master is the result of my own research, except where otherwise acknowledged, and that this thesis (or any part of the same) has not been submitted for a higher degree to any other university or institution.

Signed:

Ahmad Zuhier Abdo

Date:

Acknowledgments

I would like to thank Dr. Hanna Abdel Nour for his guidance, encouragement, advices and insightful comments during my work period.

I would like to express my sincere gratitude to Dr. Ali Jamoos for also his guidance, encouragement, advices and insightful comments. A special thank to him for offering related references (books, scientific magazines, and IEEE papers), reviewing my reports and slides, the new ideas he proposed and commenting on the simulations and results during my whole work.

I would like to thank Dr. Eric Grivel, a members of the the Signal and Image Group (ESI) at the UMR CNRS 5218 IMS at Bordeaux1 University-France, for his advices and for his invitation to the UMR in Feb 2007.

I would like to thank Eng. Ali Abdo, a master student in Duisburg-Essen University, for his help and offering related books.

Special thanks to my colleagues in the Engineering Faculty-AIQuds University, for sharing their knowledge and experience specially Eng.Walid Hasasneh.

I would like to thank Eng. Suleiman Kirresh and Mr. Mohammad Al-Silwadi head manager and deputy director of KWIC Company respectively for their advices, patience and encouragement during my work.

I would like to thank employees of KWIC Company for their encouragement, specially Shadi Al-Kharoof, Murad Titi, Mohammad Ireqat, Sinan Abu Eid, and Mustafa Sharabati. I would like to thank my friend Eng.Yazid Al-Khatib my partner in the maintenance department for his useful help and his patience during my study.

My deep gratitude to my family, my brothers, Moheeb, Tareq, Khalil, my sisters Leyana, Rana and their families. A special thanks to my mother in low, my father of low, my cosine Eng.Omar for their support and boundless love.

I would like to deeply thank my mother and my father for the endless supports, patience and encouragements during my whole life.

Last but not least, I express my sincere gratitude to my wife Razan for her support and patience.

Abstract

Orthogonal Frequency Division Multiplexing (OFDM) is a multi-carrier modulation technique that divides a high bit rate data stream into several parallel low bit rate data streams. This scheme makes it possible to convert the severe wide-band frequency-selective fading channel into many narrow-band frequency non-selective flat fading sub-channels, which are free from *Inter-Symbol Interference* (ISI). However, due to the user mobility, each carrier is subject to Doppler shift resulting in time-varying fading. Thus, our purpose in this thesis is to estimate time-varying Rayleigh fading channels in OFDM mobile systems. When the fading channel is approximated by an *Auto-Regressive* (AR) process, the AR parameters have to be estimated from the available noisy observations. One standard solution to obtain the AR parameters consists in first fitting the AR process autocorrelation function to the theoretical Jakes one and then solving the resulting *Yule-Walker Equations* (YWE). However, this approach requires the Doppler frequency which is usually unknown. To avoid the estimation of the Doppler frequency, we propose to consider a structure based on two-cross-coupled Kalman filters. One filter is used to estimate the AR parameters and the other is used to estimate the fading process. Simulation results show the effectiveness of this approach especially in high Doppler rate environments, and can provide significant results over the *Least Mean Square* (LMS) and *Recursive Least Square* (RLS) channel estimators. Kalman filtering is optimal providing that the initial state, the driving process and the measurement noise in the space representation of the system are independent, white and Gaussian. However, in real cases, these assumptions may no longer be satisfied. To relax them, some authors proposed to use two-serially-connected H_∞ filters. The first filter is used to estimate the AR parameters and the second filter is used to estimate the fading process. Nevertheless, this approach results in biased AR parameter estimates as they are directly estimated from the noisy observations. To avoid this drawback, we propose to consider a structure based on two-cross-coupled H_∞ filters. Simulation results show that the two-cross-coupled H_∞ filter based channel estimator outperforms the one based on two-serially-connected H_∞ filters. In addition, the two-cross-coupled H_∞ filter based channel estimator provides approximately the same results as the one based on two-cross-coupled Kalman filters while avoiding the restrictive assumptions imposed by Kalman filters.

Keywords: Multi-carrier modulation, OFDM, Rayleigh fading channels, AR processes, Channel Estimation, Kalman filters, H_∞ filters.

ملخص الرسالة

(OFDM) هو نظام اتصال لاسلكي يعتمد على تقنية متعدد الناقل حيث اكتسب شعبية عالية في مجالات الاتصالات اللاسلكية في السنوات القليلة الماضية. هذا النظام يجعل من الممكن تحويل القناة عريضة النطاق (wide-band frequency selective) الى قناة حادة النطاق (narrow-band frequency non-selective) تخلو من اي نوع من التداخل (ISI). لكن نظرا لتنقل و حركة المستخدم فان كل ناقل يتعرض الى ما يسمى تأثير (Doppler effect) مما يجعل قناة الاتصال متغيرة و معتمدة على الزمن. الهدف من هذه الاطروحة هو تقدير هذا التغير في قنوات الاتصال لنظام (OFDM).

عند تقدير التغيرات في قناة الاتصال يتم استخدام ما يسمى نموذج (Auto Regressive) فان هذا النموذج يحتاج الى تعريف بعض العوامل (parameters). في الواقع لا يمكن الحصول على هذه العوامل بل يجب تقديرها و بالتالي الحصول على التغيرات الحاصلة على قناة الاتصال. من احدى الطرق المستخدمة هي اللجوء الى نودج جاكس (Jakes model) حيث يتم اللجوء من خلاله الى حل معادلة (Yule-Walker) و بالتالي الحصول على هذه العوامل و لكن هذه الطريقة تحتاج الى (Doppler frequency) وهو في العادة غير معروف. لذا تم اللجوء الى استخدام بعض المرشحات (Filters) مثل (Two-cross-coupled Kalman filters) و فيه يقوم المرشح الاول بتقدير العوامل بينما يقوم الاخر بتقدير القناة (Channel). تم بناء هذا المرشح المزدوج واعطى نتائج افضل مقارنة بالمرشح (LMS) و المرشح (RLS). ولكن هذا المرشح (Two-cross-coupled Kalman filters) يحتاج الى شروط و ضوابط قبل استخدامه وهي غير متوفرة في بعض الاوقات لذلك اقترح بعض المؤلفين استخدام ما يسمى بالمرشح (two-serially-connected H_{∞} filters) ولكن هناك نسبة خطأ يعطيها هذا المرشح في قيم العوامل لذلك تم اللجوء الى استخدام (two-cross-coupled H_{∞} filters) حيث انه لا يحتاج الى ضوابط و يعطي نتائج مماثلة للمرشح (Two-cross-coupled Kalman filters) . حصلت المرشحات المقترحة على نتائج افضل بالمقارنة مع المرشحات المستخدمة والمقترحة من بل بعض الباحثين.

Contents

Thesis Approval	i
Dedication	ii
Declaration	iii
Acknowledgment	iv
Abstract	v
Table of contents	vii
List of Figures	ix
1. Introduction	1
1.1 Motivation.....	2
1.2 Multiple Access techniques.....	3
1.3 Why OFDM.....	6
1.4 Contributions of the thesis.....	7
1.5 Outlines of the thesis.....	8
2. Description of OFDM Wireless System	9
2.1 Introduction.....	10
2.2 Parallel Transmission.....	10
2.3 The concept of OFDM.....	11
2.4 Emergaing OFDM wireless commutation systems.....	12
2.4.1 Digital broadcasting systems, DAB & DVB.....	12
2.4.2 Wireless Local Area Networks, WLANs.....	12
2.4.3 World Interoperability for Microwave Access, WiMAX.....	13
2.5 OFDM System Model.....	13
2.5.1 The transmitter Model.....	15
2.5.1.1 The Inverse Fast Fourier Transform as Modulation.....	15
2.5.1.2 The Guard Interval.....	16
2.5.2 The Channel Model.....	17
2.5.3 The receiver Model.....	18
2.6 Simulation Results.....	20
3. Channel Characterization and Modeling	21
3.1 Introduction.....	22
3.2 Fading channel characteristics.....	22
3.2.1 Frequency selective and frequency non selective fading.....	23

3.2.2 Slow and fast fading.....	24
3.2.3 Doppler shift and time-varying fading.....	25
3.2.4 Rayleigh fading.....	26
3.3 Modeling of fading channels.....	30
3.3.1 Sum of sinusoidal simulation model.....	30
3.3.2 Autoregressive channel model.....	31
4. Estimation of Auto regressive OFDM Fading Channels.....	34
4.1 State of the art.....	35
4.2 Channel estimator based on the LMS and RLS algorithms.....	36
4.3 Estimation of the fading process based on Kalman filter.....	37
4.4 Relevance of the H_∞ filtering for fading process estimation.....	39
4.5 Two serially connected Kalman or H_∞ filters.....	42
4.6 Two cross coupled Kalman filters.....	43
4.6.1 Estimation of the AR parameters.....	43
4.6.2 Estimation of the driving process variance.....	44
4.6.3 Operation of the channel estimator.....	44
4.6.4 Simulation Results.....	45
4.7 Two cross coupled H_∞ filters.....	48
4.7.1 Estimation of the AR parameters.....	48
4.7.2 Tuning the weighting parameters.....	49
4.7.3 Operation of the channel estimator.....	50
4.7.4 Simulation Results.....	50
5. Conclusions and Future Work.....	54
Conclusion.....	55
Future Work.....	55
Acronyms and Abbreviations.....	57
Notations.....	59
Appendix A.....	60
Appendix B.....	66
Appendix C.....	71
References.....	72

LIST OF FIGURES

Figure 1.1: Cellular users' growth worldwide according to ITU database.....	2
Figure 1.2: FDMA.....	4
Figure 1.3: TDMA.....	4
Figure 1.4: CDMA.....	6
Figure 2.1: Parallel transmission systems.....	11
Figure 2.2: Comparison of bandwidth for FDM and OFDM modulation techniques.....	11
Figure 2.3: Channel bandwidth for WiMAX.....	13
Figure 2.4: Spectrum of 5 subcarriers of OFDM.....	14
Figure 2.5: OFDM Transmitter.....	15
Figure 2.6: Modulation of OFDM system using IFFT.....	16
Figure 2.7: Fading channel and AWGN.....	17
Figure 2.8: OFDM receiver structure.....	18
Figure 2.9: BER performance of OFDM system without the effect of fading.....	20
Figure 3.1: Multi-path fading in wireless mobile systems.....	23
Figure 3.2: Illustration of the Doppler shift.....	25
Figure 3.3: Envelope of Rayleigh fading process.....	26
Figure 3.4: Phase of Rayleigh fading process.....	27
Figure 3.5: The autocorrelation function of the fading channel.....	28
Figure 3.6: The Doppler power spectrum density.....	29
Figure 3.7: Power spectral density of the Jakes model and that of the fitted AR (p) process with $p=1, 2, 5,$ and 20	33
Figure 3.8: Autocorrelation function of the Jakes model and that of the fitted AR (p) process with $p=1, 2, 5,$ and 20	33
Figure 4.1: Two serially connected Kalman filter for an estimation of the fading process and its AR parameters along the m th carrier.....	42
Figure 4.2: Two-cross-coupled Kalman filter based structure for the joint estimation of the fading process and its AR parameters along the m th carrier.....	43
Figure 4.3: Real and imaginary parts of the estimated AR(2) parameters using two-cross-coupled Kalman filters.....	46
Figure 4.4: MSE versus SNR of the OFDM system with the various channel estimators.....	47

Figure 4.5: BER performances versus SNR of the OFDM system with the various channel estimators.....47

Figure 4.6: Two-cross-coupled H_∞ filters.....48

Figure 4.7: BER performance versus SNR of the OFDM system. The AR model order is $p=2$ and $p=5$51

Figure 4.8: BER versus SNR of the OFDM system with the various channel estimators with AR order 1, 2, 5 and 20.....52

Figure 4.9: Real and imaginary parts of the estimated AR(2) parameters using two-cross-coupled H_∞ filter.....53

Figure 5.1: OFDMA.....56

Chapter 1

Introduction

Contents

1.1 Motivation.....	2
1.2 Multiple Access techniques.....	3
1.3 Why OFDM.....	6
1.4 Contributions of the thesis.....	7
1.5 Outlines of the thesis.....	8

1.1 Motivation

Due to the increasing demand on mobile wireless communication industry and the increasing number of mobile users, wireless communication technology became one of the most important fields to be studied. Figure 1.1 shows the rapid increasing of cellular users till 2005 according to the *International Telecommunication Union (ITU)* statistic database. In 1991, the number of mobile users is not exceeding 100,000 users. But in 2005 this number exceeds 2 billion users as shown in Figure 1.1.

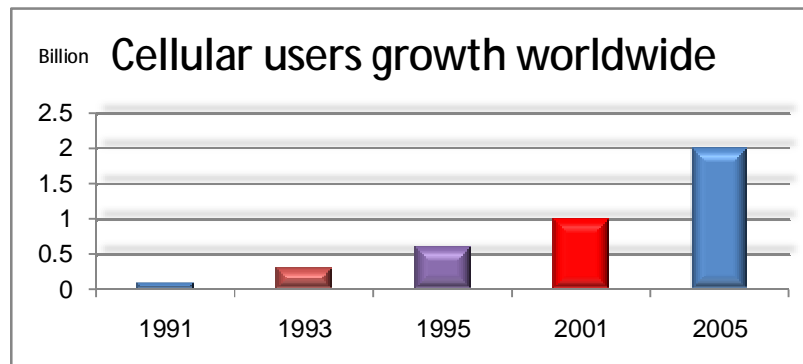

Figure 1.1: Cellular users' growth worldwide according to ITU database

Many mobile radio standards have been developed for wireless communication throughout the world. A classification to mobile communication development has been known as mobile generations. Each generation is different from the others, according to the used multiple access technique, modulation techniques, data rate, types of data to be transferred between the transmitter and the receiver, number of users, etc. *First Generation (1G)* mobile systems used *Frequency Division Multiple Access (FDMA)*. At that time analog transmission was used in all systems. Among these systems are *Nordic Mobile Telephony (NMT)* that mainly been used in the Nordic countries and *Advanced Mobile Phone System (AMPS)* which is introduced in the Americas. *Second Generation (2G)* mobile systems used *Time Division Multiple Access (TDMA)*. 2G phone systems were characterized by digital circuit switched transmission and the introduction of advanced and fast phone to network signaling. *Group Special Mobile (GSM)* is the most popular standard for mobile phones in the world. It is developed to be used in Europe. *Integrated Digital Enhanced Network (iDEN)* is a mobile telecommunications technology, developed by Motorola, and provide users with the benefits of a trunked radio and a cellular telephone. It is use

popularly in USA. 2G mobile systems also used *Code Division Multiple Access* (CDMA). *Interim Standard 95* (IS-95) is the first CDMA-based digital cellular system developed in USA. Due to the exponential increase in the number of users for mobile cellular communications CDMA, with its proven capacity enhancement over TDMA and FDMA, has been chosen as the main multiple access scheme for the *Third Generation* (3G) mobile cellular systems [Abb05]. *International Mobile Telecommunications* (IMT-2000) is the global standard for 3G wireless communications. With the existing Multiple Access schemes, several technical issues prevent us from achieving such a high transmission rate [Jama05]. In *Beyond 3G* (B3G) mobile systems, high data rate transmission on the order of 10 Mb/s and more is expected by adopting new multiple access techniques. Multicarrier DS-CDMA (MC/DS-CDMA) scheme has received much attention as one promising multiple access schemes for B3G systems [Yan03] [Jam07a]. To achieve high data rate in the B3G, OFDM has attracted much attention, particularly in the emerging IEEE 802.16 wireless communications standard [Xia03] [Ekl02].

1.2 Multiple Access Techniques

Multiple access schemes are used to allow many mobile users to share simultaneously a finite amount of radio spectrum for high quality communication [Rap01]. This must be done without degradation in the performance of the system. FDMA assigns individual channel for individual user as shown in Figure 1.2. Low *Inter-Symbol Interference* (ISI)¹ is one of the advantages of FDMA [Yee93]. In this case, users are assigned a channel as a pair of frequencies, forward and reverse to get a full duplex² communication. The first analog cellular system, the *Nippon Telephone and Telegraph* (NTT) system became operational in 1985. In 1983, *American Telephone and Telegraph* (AT&T) fielded the *Advanced Mobile Phone Service* (AMPS) as a trial in Chicago [Stü02].

¹ **Inter symbol Interference (ISI):** is a form of distortion of a signal in which one symbol interferes with subsequent symbols. It is usually caused by multipath propagation of the channel.

² **Duplexing** Allow the user to send simultaneously information while receiving information “talk and listen simultaneously”. a) *Frequency division duplex* (FDD) two frequencies for every users one for the forward and the other for the reverse “or called uplink, downlink”. b) *Time division duplex* (TDD) using time instead of the frequency for both forward and reverse.

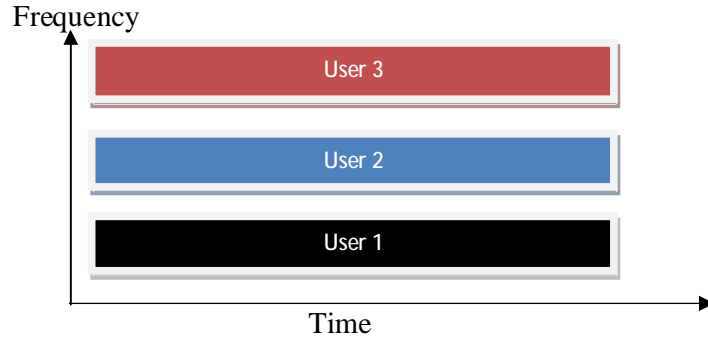

Figure 1.2: FDMA

The 2G systems, which have been developed in the 1990s, use TDMA as the main multiple access technique. In TDMA systems the radio spectrum is divided into time slots (see Figure 1.3), where one user is allowed in each slot [Rap01]. This means single carrier frequency with several users. 2G systems include GSM in Europe, *Personal Digital Cellular* (PDC) system in Japan, and the IS 54-/136 and IS-95 systems in the USA [Stü02].

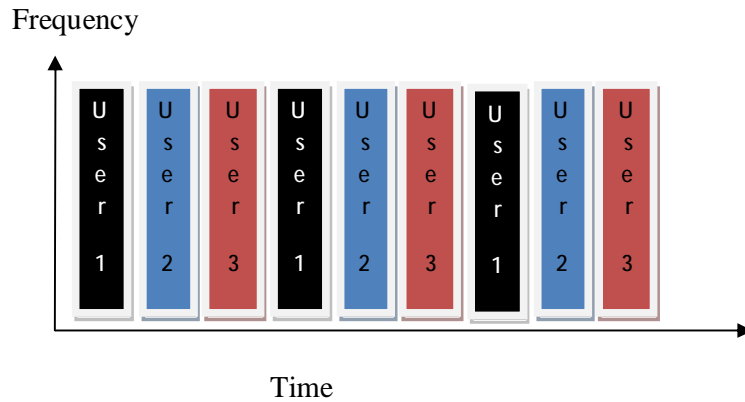

Figure 1.3: TDMA

GSM is the first cellular system that allows roaming³ throughout Europe. The *Conference of European Postal and Telecommunications administrations* (CEPT) established GSM in 1982 with the mandate of defining standards for future Pan-European cellular radio systems [Stü02]. Most GSM systems operate in the 900 MHz and 1.8 GHz frequency bands, except in North America where they operate in the 1.9 GHz band. GSM divides up the radio

³ **Roaming:** ability for a cellular customer to automatically make & receive voice calls, send & receive data, or access other services when travelling outside the geographical coverage area of the home network

spectrum bandwidth by using a combination of Time- and Frequency Division Multiple Access (TDMA/FDMA) schemes on its 25 MHz wide frequency spectrum. This spectrum is divided into 124 channels, each with 200 KHz. Each channel is then divided into eight time slots using TDMA, and one or more radio channels are assigned to each base station [Sel99].

TDMA also used in 2.5G systems evolved from GSM, namely *General Packet Radio Service* (GPRS) and *Enhanced Data rate for GSM Evolution* (EDGE). They use packetized data transmission and provide much higher data rates than the 2G systems.

The disadvantage of FDMA and TDMA techniques is that both have a fixed number of users as fixed number of frequency and time slots are allowed. Also, these multiple access techniques cannot satisfy the increasing channel for new types of data services (e.g. multimedia, video, images ..., etc) with high data rate requirements. To satisfy these requirements, CDMA was emerged as a possible solution. In CDMA each user is assigned a unique code sequence which is used to encode the user's information-bearing signal. The receiver, knowing the code sequence of the user, decodes the received signal after reception and recovers the original data. This is possible since the cross correlations between the code of the desired user and the codes of the other users are small. Since the bandwidth of the code signal is chosen to be much larger than the bandwidth of the information-bearing signal, the encoding process enlarges (spreads) the spectrum of the signal and is therefore also known as spread-spectrum modulation [Pra98]. The capacity of CDMA system is not fixed and a new user can be added to the system at any time. CDMA can be described as shown in Figure 1.4. For example, the IS-95 standard employs CDMA type of access method. In downlink, channels are identified by the orthogonal Walsh code of 64-chip length. Among the 64 channels, one is used as a pilot channel, seven are used as paging channels and 55 are used as traffic channels [Liu05].

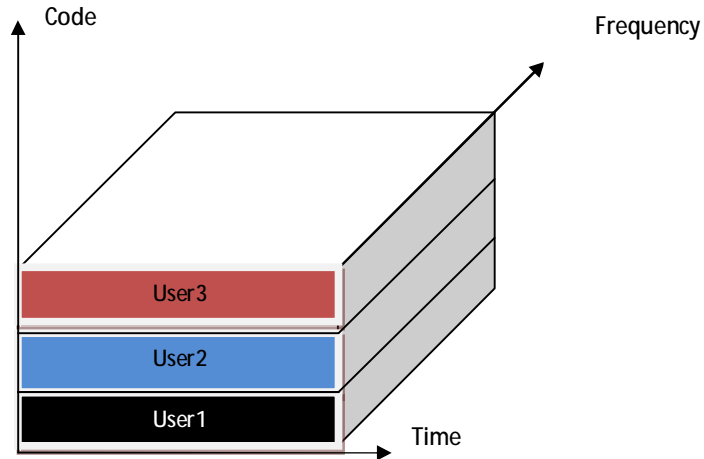

Figure 1.4: CDMA

To support the requirements of the new emerging high data rate multimedia services, several techniques have been studied for the last years. OFDM is suitable for high-data rate communications and has high resistance to ISI. In the next section we will motivate the selection of OFDM and provide the advantages of OFDMA over other multiple access techniques.

1.3 Why OFDM?

OFDM is a parallel data transmission technique in which high data rates can be achieved by the simultaneous transmission over many orthogonal carriers, resulting in high band-width efficiency [Bin90] [Wan00]. In addition, this multi-carrier transmission technique makes it possible to convert the severe wide-band frequency-selective fading channel into many frequency-flat fading sub-channels. Due to its core advantages in high-data rate communication systems, OFDM has become the modem of choice for a number of high profile wireless systems, such as *Digital Video Broadcasting (DVB)*, *Wireless Fidelity (Wi-Fi)*, *Worldwide Interoperability for Microwave Access (WiMAX)* [Liu05]. The concept of OFDMA⁴ is essentially the same as FDMA, but it has some advantages over FDMA (e.g., Bandwidth efficiency, high data rate ... etc). OFDM can be defined as a form of multi-carrier modulation where each carrier is orthogonal to the other carriers. The

⁴ Although we are focusing our attention on OFDM, the extension to OFDMA is straight forward.

OFDM overcomes most of the problem of FDMA and TDMA. For example the limits of the number of users in both TDMA and FDMA are overcome in OFDM technique by dividing total bandwidth into independent sub-channel, multiple access is achieved by distributing sub-channels between users and hence OFDMA. To generate an OFDM system, the relation between the carriers must be controlled to be orthogonal. OFDM can be easily implemented by using *Fast Fourier Transform* (FFT) and *Inverse FFT* (IFFT⁵). The following points summarize the benefits of OFDM and OFDMA:

- a) High data rates.
- b) High bandwidth efficiency
- c) Converts the frequency-selective fading channel into many frequency non-selective flat fading sub-channels.
- d) Parallel transmission schemes that are free from ISI.

OFDM has some disadvantages like:

- a) High peak-to-average-power ratio.
- b) Frequency offset and phase noise.

1.4 Contributions of the thesis

In OFDM systems, due to user mobility, each carrier is subject to Doppler shifts resulting in time-varying fading. Thus the estimation of time-varying flat fading channel over each carrier is a major challenge for reliable transmission. The time-variation of each carrier fading channel is usually modeled as a zero-mean wide-sense stationary complex Gaussian process, whose stochastic properties depend on the maximum Doppler frequency f_d . According to [Jak74], the theoretical power spectrum density (PSD) associated with the fading process is band-limited, U-shaped and exhibits twin peaks at $\pm f_d$. However, this key feature about the channel is not exploited when directly estimating the fading process by means of the *Least Mean Square* (LMS) or the *Recursive Least Square* (RLS) algorithms as in [Kal03].

On the other hand, when a p th order autoregressive model, denoted by $AR(p)$, is used to approximate the time evolution of the fading process [Bad05], Kalman filtering can be carried out and is shown to provide lower *Bit Error Rate* (BER) than the model independent LMS and RLS based channel estimators [Kom02]. However, the AR model

⁵ FFT is equivalent to demodulation part of the transmission process. The IFFT is equivalent to the modulation part

order has to be selected and the AR parameters have to be estimated. One standard solution to obtain the AR parameters consists in first fitting the AR process autocorrelation function to the theoretical Jakes one and then solving the resulting *Yule-Walker Equations* (YWE). However, this approach requires the Doppler frequency which is usually unknown. To avoid the estimation of the Doppler frequency, the joint estimation of both the channel and its AR parameters can be addressed. Thus, we propose to investigate the relevance of the two methods [Lab06] [Lab07] for the estimation of the OFDM fading channel:

- We first investigate the relevance of the two-cross-coupled Kalman filters [Lab06] for the joint estimation of the fading process and its AR parameters over each carrier in OFDM system [Jam07c]. A comparative study on the estimation of OFDM fading channel is then carried out with the traditional LMS and RLS channel estimators.
- To avoid the restrictive Gaussian assumption imposed by Kalman filtering, we then investigate the relevance two-cross-coupled H_∞ filters [Lab07] for the estimation of OFDM fading channel [Jam08]. The comparative study we carried out on the estimation of OFDM fading channel between the two-cross-coupled H_∞ filters and the existing two-serially connected H_∞ filters [Cai04] shows that the former approach outperforms the later one.

1.5 Outlines of the thesis

In chapter 1, an introduction to wireless mobile communication systems is presented. An evolution of the mobile generations toward the fourth Generation (4G) is presented, and a brief history of the multiple access techniques is investigated.

In chapter 2, the OFDM wireless systems are presented. The OFDM transmitter model, the receiver structure and the channel model are described clearly.

In chapter 3, the OFDM channel characterization and modeling is presented. A sum-of-sinusoidal simulation models is adopted to simulate the fading channel and the AR model is used for channel prediction.

In chapter 4, the estimation of time-varying Rayleigh fading channels in OFDM mobile systems is carried using various filters. A comparative study of the proposed filters has been carried out using various filters.

In chapter 5, conclusion and recommendation for future work is drawn.

Chapter 2

Description of OFDM Wireless System

Contents

2.1 Introduction	10
2.2 Parallel Transmission	10
2.3 The concept of OFDM	11
2.4 Emergaing OFDM wireless commutation systems	12
2.4.1 Digital broadcasting systems, DAB & DVB.....	12
2.4.2 Wireless Local Area Networks, WLANs.....	12
2.4.3 World Interoperability for Microwave Access, WiMAX.....	13
2.5 OFDM System Model	13
2.5.1 The transmitter Model.....	15
2.5.1.1 The Inverse Fast Fourier Transform as Modulation.....	15
2.5.1.2 The Guard Interval.....	16
2.5.2 The Channel Model.....	17
2.5.3 The receiver Model.....	18
2.6 Simulation Results	20

2.1 Introduction

Multimedia is effectively an important technology with widely different origins in computing and telecommunications. New applications are emerging, not just in the wired environment, but also in the mobile one. At present, low bit-rate data services are available to the mobile users. However, demands of the wireless multimedia broadband system are need in many technologies [Har01].

Multimedia communication has rather large demands upon bandwidth and quality of service (QoS) compared to what is available today to the mobile user. The question is how to put these large bits with sufficient QoS guaranties, i.e., which modulation can compromise all contradicting requirements in the best manner. The radio environment is not trustable, due to the many reflected waves, noises and other effects. Using adaptive equalization techniques at the receiver could be the solution, but there are practical difficulties in operating this equalization in real-time at several Mb/s with compact, low-cost hardware. A good choice that eliminates a need for the complex equalizers is the OFDM, a multiple carrier modulation technique. In this chapter, the multi-carrier modulation system is firstly described. The applications of OFDM are then outlined. The OFDM system model will then be clearly described.

2.2 Parallel Transmission

In wireless communication, the received signal arrives at the receiver from many paths due to reflection, diffraction and scattering. Thus, multipath with different delay, signal power and phases are received at the receiver. When the transmitted signal suffers from the multipath fading, the received signal will be affected by ISI.

To combat the problem caused by a multipath fading, it is necessary to use a parallel transmission. The parallel transmission is a method of sending several data signals over a communication link at one time. It converts the high speed data into slow parallel data in several channels.

Figure 2.1(a) shows multi-code transmission. In multi-code a unique code is given to each symbol that can be easily retrieved at the receiver. It is the standard of CDMA.

Figure 2.1(b) shows parallel transmission FDMA that called multicarrier transmission [Wan00], which is the standard of OFDM.

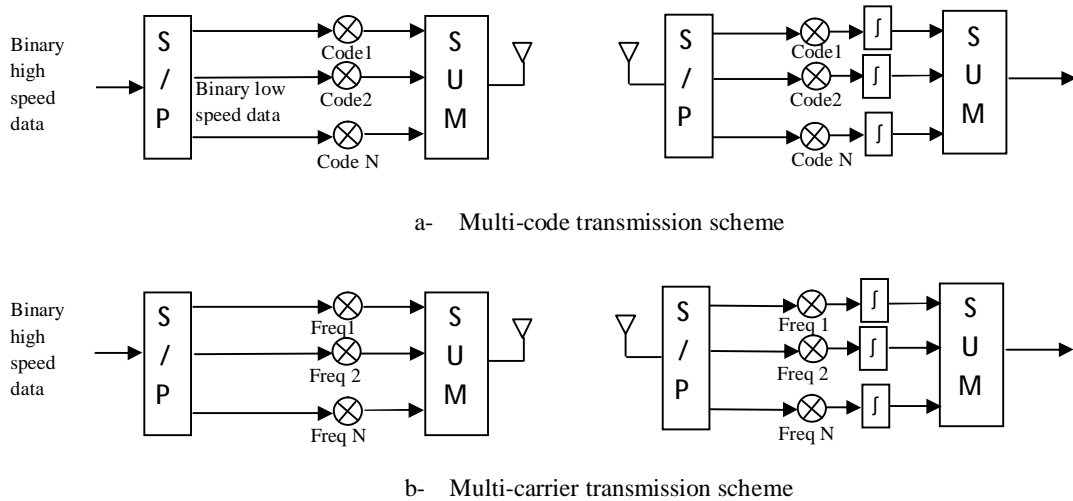

Figure 2.1 Parallel transmission systems

2.3 The concept of OFDM

The concept of using parallel data transmission by means of FDM was published in mid 1960s [Sal67]. The idea was to use parallel data streams and FDM with overlapping sub-channels to avoid the use of high speed equalization and to combat impulsive noise, and multipath distortion as well as to fully use the available bandwidth. The initial applications were in the military communications. In the telecommunications field, the terms of *Discrete Multi-Tone* (DMT), multichannel modulation and *Multi-Carrier Modulation* (MCM) are widely used and sometimes they are interchangeable with OFDM. In OFDM, each carrier is orthogonal to all other carriers. However, this condition is not always maintained in MCM. OFDM is an optimal version of multicarrier transmission schemes in which high bandwidth efficiency can be achieved as shown in Figure 2.2.

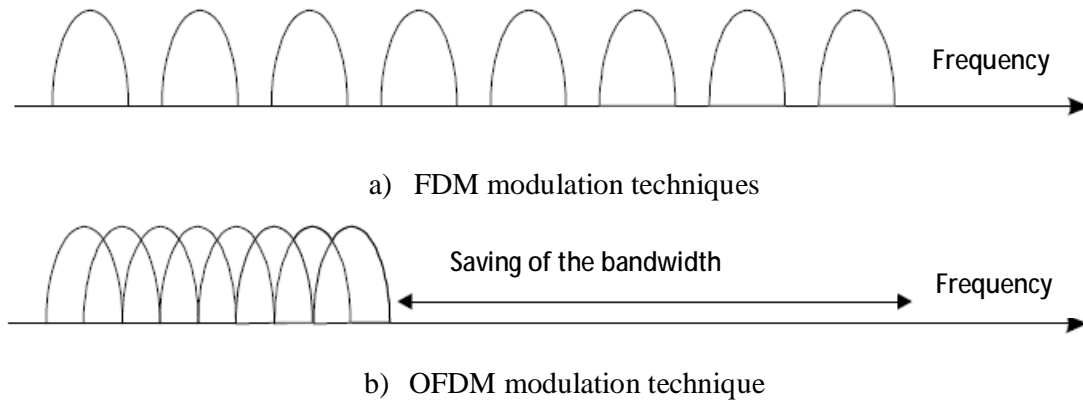

Figure 2.2 Comparison of bandwidth for FDM and OFDM modulation techniques

For a large number of sub-channels, the arrays of sinusoidal generators and coherent demodulators required in a parallel system become unreasonably expensive and complex. The receiver needs precise phasing of the demodulating carriers and sampling times in order to keep crosstalk between sub-channels acceptable. Weinstein and Ebert [Wei71] applied the *Discrete Fourier Transform* (DFT) to parallel data transmission system as part of the modulation and demodulation process. In addition to eliminate the banks of subcarrier oscillators and coherent demodulators required by FDM, a completely digital implementation could be built around special-purpose hardware performing the FFT.

In the 1980s, OFDM has been studied for high-speed modems, digital mobile communications and high-density recording. Various fast modems were developed for telephone networks.

In 1990s, OFDM has been exploited for wideband data communications over mobile radio FM channels, *High-bit-rate Digital Subscriber Lines* (HDSL, 1.6 Mb/s), *Asymmetric Digital Subscriber Lines* (ADSL, 1,536 Mb/s), *Very High-speed Digital Subscriber Lines* (VHDSL, 100 Mb/s), *Digital Audio Broadcasting* (DAB).

2.4 Emerging OFDM wireless commutation systems

OFDM has been proposed for a variety of applications including ADSL, DAB, DVB, WLAN and WiMAX. In this section, we discuss the use of OFDM in such applications.

2.4.1 Digital broadcasting systems

OFDM systems have been proposed to transform from old analog broadcasting systems to new digital broadcasting systems. For example, in Europe OFDM has been adopted for DAB [EST95] and terrestrial DVB [EST97].

OFDM with coding and interleaving techniques, i.e., coded orthogonal frequency division multiplexing (COFDM), has been selected for digital broadcasting systems due to its capability to combat multi-path propagation and narrowband interference.

2.4.2 Wireless LANs (WLANs)

Growing interest in high speed wireless packet switched services, such as wireless Internet access, wireless multimedia, advances in integrated personal computers and communication devices. OFDM has been selected as the basis for the physical layer of a number of packet

based indoor wireless LAN standards such as the HIPERLAN2 [ETS00] and the IEEE 802.11a [IEE99].

2.4.3 Worldwide Interoperability for Microwave Access (WiMAX)

WiMAX is a wireless digital communications system, also known as IEEE 802.16 that is intended for wireless "metropolitan area networks". WiMAX can provide *Broadband Wireless Access* (BWA) up to 30 miles (50 km) for fixed stations, and 3 - 10 miles (5 - 15 km) for mobile stations

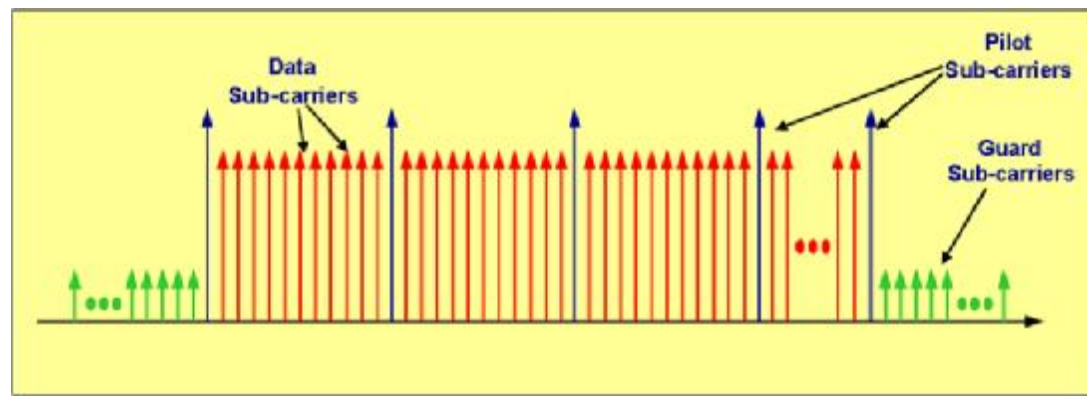

Figure 2.3: Channel Bandwidth of WiMAX

Figure 2.3 shows the carriers used in WiMAX. In WiMAX only 200 of 256 subcarriers are used: 192 data subcarriers + 8 pilot subcarriers. There are 56 "nulls" (center carrier, 28 lower frequency and 27 higher frequency guard carriers).

2.5 OFDM System Model

The main advantage of Multi-carrier and parallel data system is to protect the system from inter-symbol interference (ISI). OFDM system is a multicarrier modulation technique that allows overlapping frequency sub-channels. In this system, each subcarrier is made to be orthogonal to every other subcarriers in the system. Figure 2.4 shows the spectrum of OFDM and shows the orthogonality between the carriers.

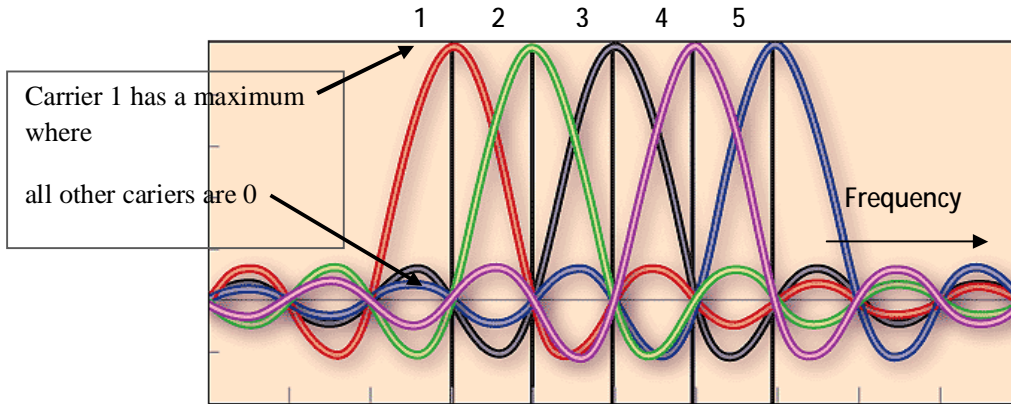

Figure 2.4: Spectra of 5 subcarriers of OFDM

The importance of orthogonality

The orthogonality in OFDM indicates that there is a precise mathematical relationship between the carriers in the system. In FDM system, the many carriers are spaced apart in such way that the signals can be received using conventional filters. In such receivers, guard bands have to be introduced between the different carriers, see Figure 2.2(a), and the introduction of these guard bands in the frequency domain results in a lowering of the spectrum efficiency. It is possible to arrange the carriers in an OFDM signal so that the sidebands of the individual carriers overlap and the signals can still be received without adjacent carrier interference [Bul98]. In order to do this, the carriers must be designed to be orthogonal. The receiver acts as a bank of demodulators, the resulting signal then being integrated over a symbol period to recover the raw data.

Mathematically, the signals are orthogonal if

$$\int_0^{T_s} e^{j\omega_q t} e^{j\omega_p t} dt = \begin{cases} \mathbf{1} & \text{for } p = q \\ \mathbf{0} & \text{for } p \neq q \end{cases} \quad (2.1)$$

where T_s is a symbol period.

In the following, we will describe the transmitter model, the channel model and the receiver structure of the OFDM system.

2.5.1 The transmitter model

A block diagram of the transmitter is shown in Figure 2.5. In the OFDM transmitter model, the input serial data stream is firstly converted into parallel data blocks. An IFFT is performed on each block.

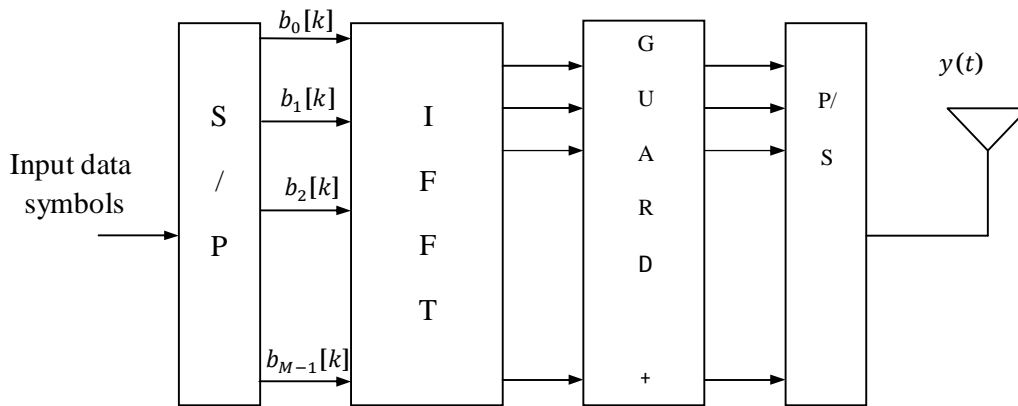

Figure 2.5: OFDM Transmitter.

Where

$b_m[k]$: the input data symbol of m carrier

2.5.1.1 Inverse Fast Fourier Transform (IFFT) as Modulation

It has been difficult to generate a modulated signal, and even harder to receive and demodulate that signal. The hardware solution, which makes use of multiple modulators and demodulators, was somewhat impractical for use in the civil systems.

The ability to define the signal in the frequency domain and to generate the signal using the IFFT is the key to its current popularity.

Let us consider the block diagram shown in Figure 2.6 that describes the IFFT as a modulation step where $b_m[k]$ is the symbol k over m th carrier, M is the number of carriers and w_m is Frequency of m th carrier.

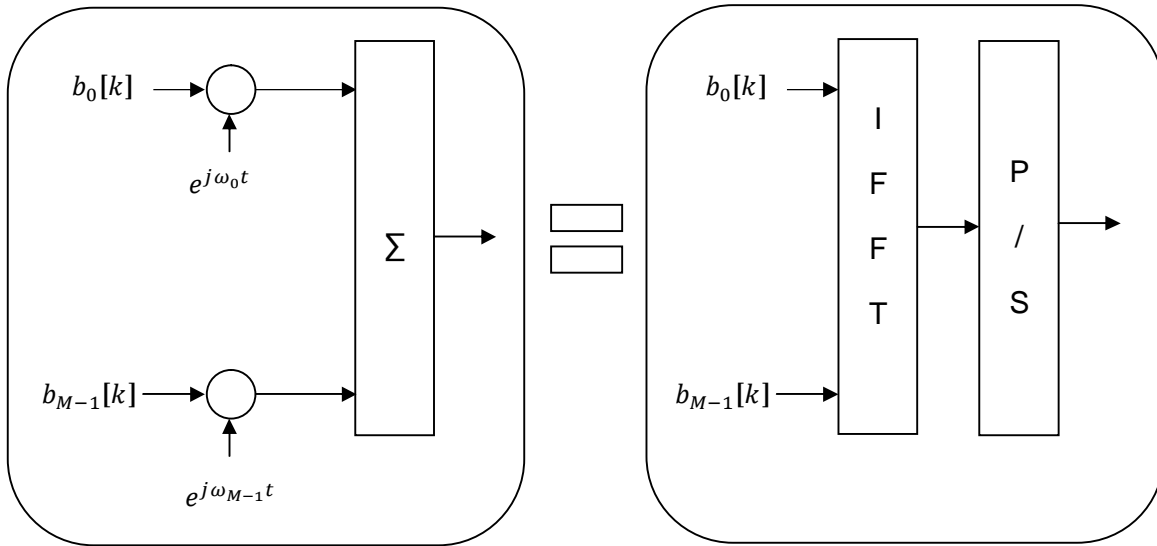

Figure 2.6: Modulation process in OFDM system using IFFT.

The third part in the transmitter of OFDM system is the guard interval. What is the guard interval? and why it is used in OFDM system?

2.5.1.2 Guard Interval

The orthogonality of sub-channels in OFDM can be maintained and individual sub-channels can be completely separated by the FFT at the receiver when there are no inter-symbol interference (ISI) and inter-carrier interference (ICI) introduced by transmission channel distortion. In practice these conditions cannot be obtained. Since the spectra of an OFDM signal is not strictly band limited ($\text{sinc}(f)$ function), and the multipath propagation causes ISI. A simple solution is to increase symbol duration or the number of carriers so that distortion becomes insignificant. However, this method may be difficult to implement in terms of carrier stability, Doppler shift and FFT size.

One way to prevent ISI is to create a cyclically extended guard interval, where each OFDM symbol is preceded by a periodic extension of the signal itself. The total symbol duration is $T_{Total} = T_g + T_s$, where T_g is the guard interval and T_s is the symbol duration. When the guard interval is longer than the channel impulse response, or the multipath delay, the ISI can be eliminated.

Cyclic convolution can still be applied between the OFDM signal and the channel response to model the transmission system.

The transmitted OFDM signal $y(t)$ can be expressed as follow

$$y(t) = \sum_{m=0}^{M-1} b_m[k] e^{j2\pi mt/T_s} \quad (2.2)$$

where M is the number of carriers and $b_m[k]$ is symbols over each carrier.

The transmitted signal $y(t)$ passes through the wireless channel which introduces signal distortion and additive noise.

2.5.2 The Channel model

The transmitted OFDM signal is assumed to go through a frequency selective fading channel. In addition to fading the signal also contaminated by an *Additive White Gaussian Noise* (AWGN) as shown in Figure 2.7.

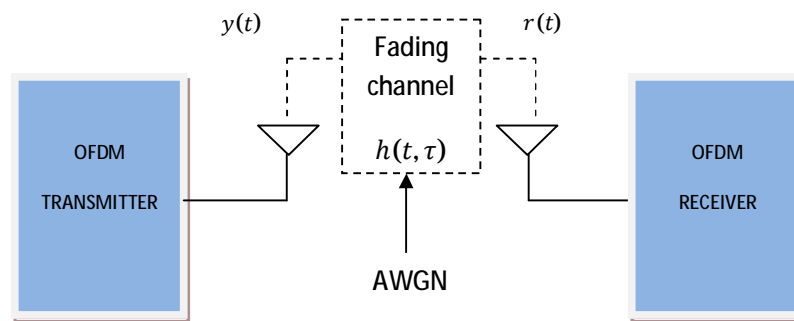

Figure 2.7 Fading channel with AWGN

where $h(t, \tau)$ is the impulse response of the channel. The channel characteristics will be discussed in chapter 3.

2.5.3 The Receiver structure

Let us consider the OFDM receiver structure shown in Figure 2.8

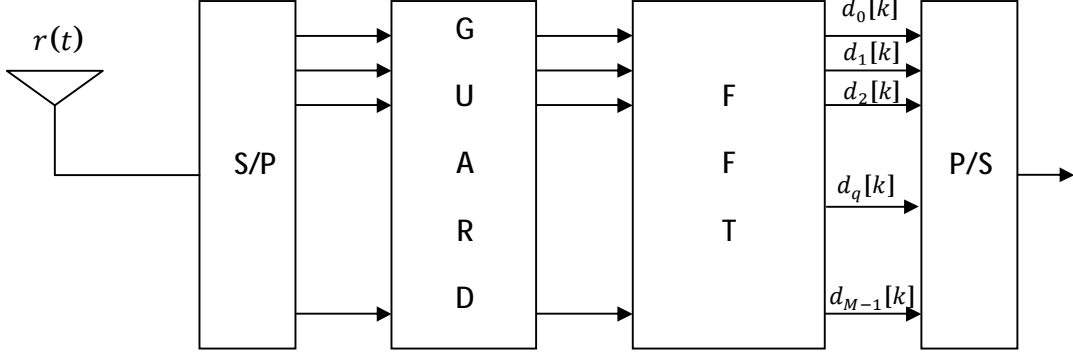

Figure 2.8: OFDM receiver structure

At the receiver, the FFT is performed on each received OFDM symbol after the guard interval being removed.

The wireless channel can be modeled as a multipath frequency-selective fading channel using a tapped-delay line with time-varying coefficients and fixed as follows [Cai04]:

$$h(t, \tau) = \sum_{l=0}^{L-1} h_l(t) \delta(\tau - \tau_l) \quad (2.3)$$

where L is the number of taps, τ_L is the maximum multipath delay spread and $h_l(t)$ is modeled as a *Wide-Sense Stationary Uncorrelated Scattering* (WSSUS) process.

The received signal from time-varying frequency-selective Rayleigh fading channel can be expressed as:

$$r(t) = h(t, \tau) * y(t) + n(t) \quad (2.4)$$

$$r(t) = \sum_{l=0}^{L-1} h_l(t) y(t - \tau_l) + n(t) \quad (2.5)$$

where $(*)$ denotes the convolution and $n(t)$ is the AWGN with variance σ_n^2 .

Now let $d_{k,q}$ be the output of FFT of q -th subcarrier with k -th symbol as shown in Figure 2.8.

$$d_{k,q} = \frac{1}{T_s} \int_{kT_s}^{(k+1)T_s} [r(kT_s)] e^{-\frac{j2\pi qt}{T_s}} dt \quad (2.6)$$

$$= \frac{1}{T_s} \int_{kT_s}^{(k+1)T_s} [\sum_{l=0}^{L-1} h_l(kT_s) y(t - \tau_l) + n(t)] e^{-\frac{j2\pi qt}{T_s}} dt \quad (2.7)$$

$$= \frac{1}{T_s} \int_{kT_s}^{(k+1)T_s} [\sum_{l=0}^{L-1} h_l(kT_s) \sum_{m=0}^{M-1} b_m[k] e^{j2\pi m(t-\tau_l)} + n(t)] e^{-\frac{j2\pi qt}{T_s}} dt \quad (2.8)$$

According to Cai *et al.* [Cai04], it follows after some manipulation that:

$$d_{k,q} = c_{k,q} H_{k,q} + v_{k,q} \quad (2.9)$$

where

$$c_{k,q} = b_q[k] \quad (2.10 a)$$

$$H_{k,q} = \sum_{l=0}^{L-1} h_l(kT_s) e^{-\frac{j2\pi q\tau_l}{T_s}} \quad (2.10 b)$$

$$v_{k,q} = \frac{1}{T_s} \int_{kT_s}^{(k+1)T_s} n(t) e^{-\frac{j2\pi qt}{T_s}} dt \quad (2.10 c)$$

Equation 2.9 represents the received signal samples that will be used for channel estimation in chapter 4.

2.6 Simulation Results of the OFDM system

A simulation is carried out for the whole OFDM system. Let us consider an OFDM with QPSK modulation, 52 carriers, and a central carrier frequency of 1900 MHz. A guard interval is 32 symbols. The BER is shown in Figure 2.9. It is compared with the theoretical value. From Figure 2.9, one can notice that theoretical BER performance is approximately equal to that obtained by simulation. In the simulation there is a small shift from the theoretical value. The theoretical *Bit Error Rate* (BER) performance value of the QPSK is given by [Pra98]:

$$BER = \frac{1}{2} \operatorname{erfc}(\sqrt{E_b/N_o}) \quad (2.12)$$

where erfc is complementary error function and E_b/N_o is the bit energy to noise power.

As we can see that the BER performance of the simulation of OFDM system gives us approximately the same as the theoretical BER

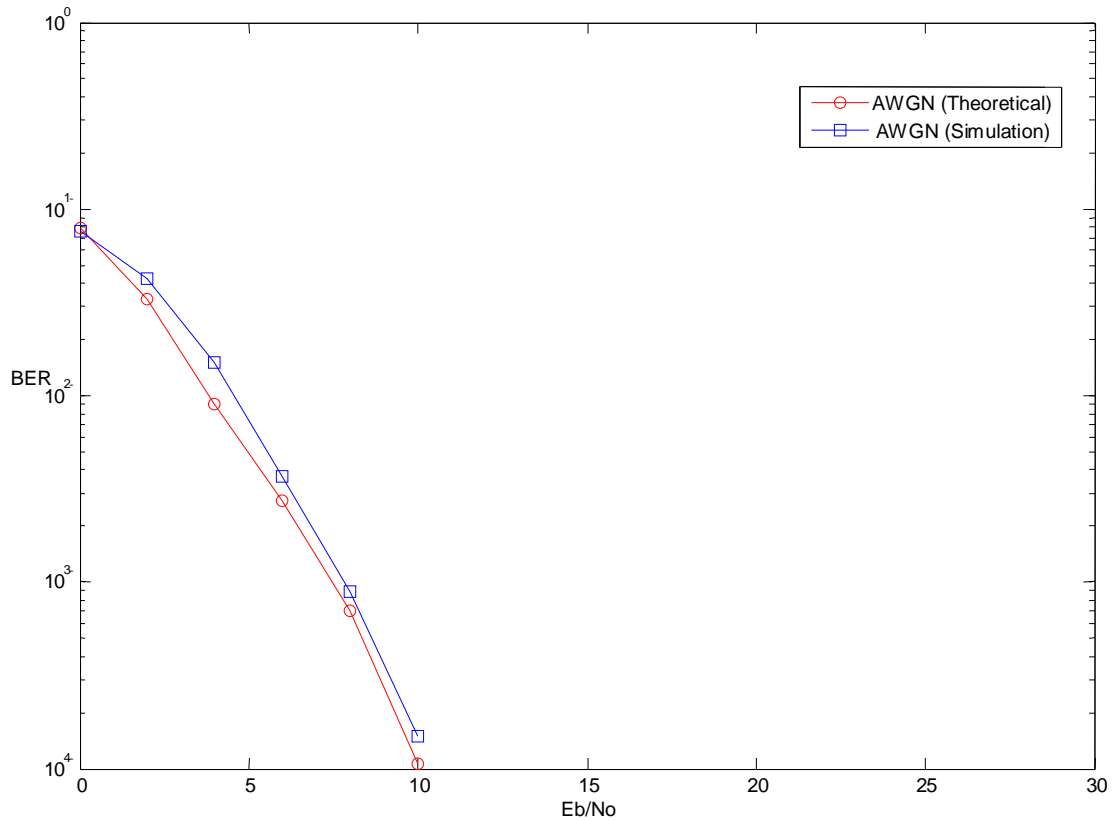

Figure 2.9: BER performance of OFDM system without the effect of fading

Chapter 3

Channel Characterization and Modeling

Contents

3.1 Introduction	22
3.2 Fading channel characteristics	22
3.2.1 Frequency selective and frequency non selective fading.....	23
3.2.2 Slow and fast fading.....	24
3.2.3 Doppler shift and time-varying fading.....	25
3.2.4 Rayleigh fading.....	26
3.3 Modeling of fading channels	30
3.3.1 Sum of sinusoidal simulation model.....	30
3.3.2 Autoregressive channel model.....	31

3.1 Introduction

In wireless communication systems, the transmitted signal arrives at the receiver from many paths. These paths arise due to reflection, diffraction, and scattering of the transmitted signal from objects like buildings, hills... etc. These unknown paths are extremely random and not easy to analyze. Modeling the radio channel is considered as the most difficult part of mobile radio system design. The transmitted signal can be attributed to reflection, diffraction and scattering. The general term *fading* is used to describe fluctuations in the envelope of a transmitted radio signal [Pup05]. Large scale fading is the fluctuation that made over a long distance. *Large scale propagation* is explained by the loss of received signal power. In the next section the small scale or the term fading will be described.

3.2 Fading Channel

Small scale or fading is the fluctuation that made over short distance or time duration. A rise to small scale fading comes from the movement of the receiver (mobile) over a small distance. There are many factors that influence fading, some of these factors are [Rap01]: -

- a) **Multipath propagation:** Due to the reflection, diffraction and scattering phenomena; a multiple versions of the transmitted signal arrive at the receiver. These multi-paths are added constructively and destructively resulting in fading.
- b) **Speed of the mobile:** The relative movement between the transmitter and the base station will cause a Doppler shift⁶ on each of the multipath components. This will lead us to a time varying fading channel. Doppler shift will be assumed to be positive or negative according the direction of the movement forward or backward to the base station.
- c) **The movement of the surrounding object:** This will cause a Doppler shift. The motion of the surrounding object will almost be neglected.
- d) **The bandwidth of the transmitted signal.**

⁶ **Doppler Shift:** is the change in frequency of a transmitted signal of a moving object

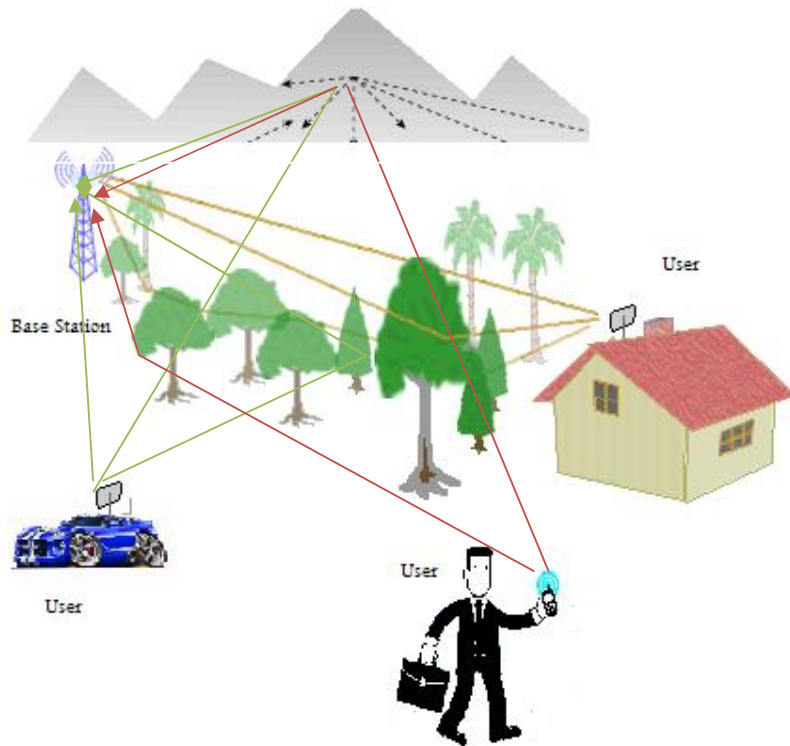

Figure 3.1: Multi-path fading in wireless mobile systems

Figure 3.1 shows a multipath fading scenario in mobile wireless systems. Multipath fading can be divided into four types:

- a) Slow or Fast fading based on *Doppler Spread and coherence time*⁷.
- b) Frequency selective or flat fading based on *Time delay spread and coherence bandwidth*⁸.

3.2.1 Frequency Selective and frequency non selective flat fading

Based on the channel coherence bandwidth and its relation with the transmitted signal bandwidth, the channel can be classified as frequency selective or non selective.

⁷ *Doppler Spread and coherence time*: parameters which describe the time varying nature of the channel in a small-scale region

⁸ *Time delay spread and coherence bandwidth*: parameters which describe the time dispersive nature of the channel in a local area

In frequency selective fading, the bandwidth of the channel is smaller than the bandwidth of the transmitted signal. This means that the delay spread of the impulse response of the channel is greater than the transmitted symbol period T_s . This will lead to a multiple version of the transmitted signal and cause a distorted received signal. While in flat fading, the bandwidth of the channel is greater than the bandwidth of the transmitted signal. Frequency selective fading is very difficult to model than flat fading since each multipath signal must be modeled. In this case, the channel impulse response can be expressed as equation (2.3).

OFDM is a multi-carrier transmission scheme. It makes possible to convert the frequency-selective fading channel into many non-selective flat fading sub-channels that are free from ISI. In this case, we can express the fading channel impulse response as:

$$h_m(t) = |h_m(t)|e^{j\varphi_m(t)}\delta(t) \quad (3.1)$$

where $h_m(t)$ is the impulse response of the fading channel, $\varphi_m(t)$ is the time varying phase of the m^{th} carrier and $|h_m(t)|$ is the time varying envelope of the m^{th} carrier .

3.2.2 Slow and Fast Fading

Depending on the changes of the transmitted signal compared to the change of the channel; a channel can be classified as *fast or slow* fading. The velocity of the receiver and the baseband signaling determines if the fading goes to fast or slow fading. Coherence time is the time domain dual of Doppler spread and is used to characterize the time varying nature of the frequency depressiveness of the channel in the time domain. In slow fading, the channel impulse response changes slower than the signal. In another word, the coherence time (T_c) of the channel is larger than the symbol period (T_s) of the transmitted signal (i.e. $T_s < T_c$).

In fast fading, the channel impulse response changes rapidly compared to the signal. This means that the coherence time of the channel is smaller than the symbol period of the transmitted signal (i.e. $T_s > T_c$) [Rap01]. Doppler spread defined as the range of frequencies over which the received Doppler spectrum is essentially non-zero. In frequency domain, if the Doppler spread of the channel is much less than the bandwidth of the signal this will lead to a slow fading. Otherwise, if the Doppler spread of the channel is more than the bandwidth of the signal then we got a fast fading.

3.2.3 Doppler Shift and time varying fading

As mentioned before, the speed of the mobile or the speed of the surrounding objects will cause a Doppler shift. Doppler shift means the change of the frequency between the transmitted and received signal. The value of Doppler shift depend on the speed of the mobile and whether the motion is toward or backward the base station. Figure 3.2 illustrates the Doppler shift in mobile system.

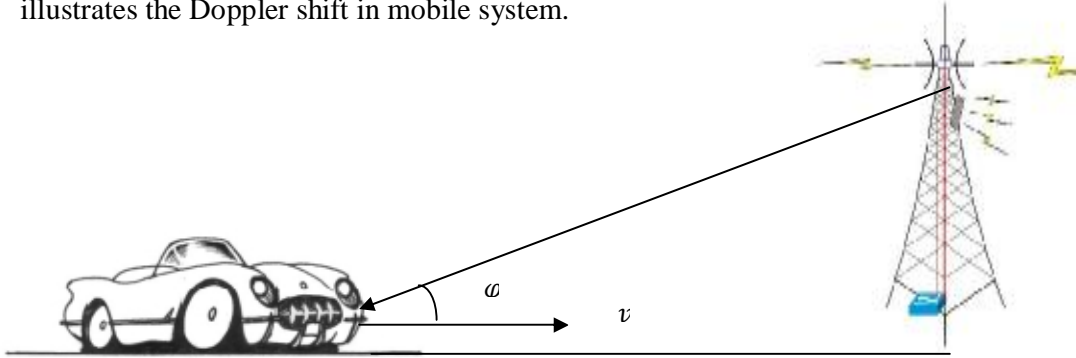

Figure 3.2: Illustration of the Doppler shift.

Let v denoted to the speed of the mobile, φ the angle of arrival, f_c the carrier frequency, and c is the speed of light, then f_D is the Doppler shift given by:

$$f_D = \frac{vf_c}{c} \cos(\varphi) \quad (3.2)$$

The maximum Doppler shift is given when $\cos(\varphi)$ reaches the maximum value:

$$f_d = \frac{vf_c}{c} \quad (3.3)$$

In multipath fading channel, the transmitted signal arrives at the receiver from L_p paths. Each path consists of large number of uncorrelated scatters (L_s) that arrives at approximately the same time. The flat fading process over the m th carriers can be modeled according to Jakes *et.al* [Jak74] as follows:

$$h_m(t) = \sum_{l=1}^{L_s} g_{ml} e^{j(2\pi f_d t \cos \varphi_{ml} + \theta_{ml})} \quad (3.4)$$

where g_{ml} , φ_{ml} and θ_{ml} are the amplitude, angle of arrival and initial phase of the l th scatter and m th carrier.

Rayleigh distribution is used to describe the statistics of the received signal envelope [Rap01], which will be discussed in the next section.

3.2.4 Rayleigh Fading

If there are a large number of scatters and according to the central limit theorem⁹ [Pap02], $h_m(t)$ can be approximated as a Gaussian process. If there is no line of sight path between the transmitter and the receiver then $h_m(t)$ will have a zero mean. In this case the phase of $h_m(t)$ is uniformly distributed over $[0, 2\pi)$ and its envelope $|h_m(t)| = h$ has a Rayleigh probability density function defined as

$$f_h(h) = \begin{cases} \frac{h}{\sigma_h^2} e^{-\frac{h^2}{\sigma_h^2}} & 0 \leq h < \infty \\ 0 & h < 0 \end{cases} \quad (3.5)$$

where σ_h^2 is the time average power of the fading signal. A typical Rayleigh fading envelope and phase are shown in Figure 3.3 and Figure 3.4 respectively. For a mobile speed 50 m/s and Doppler rate $f_d T_b = 0.0916$, the autocorrelation function of the fading process can be described as: -

$$R_{hh}(\tau) = E[h_m(t + \tau)h_m^*(t)] \quad (3.6)$$

Where $h_m(t)$ is given in equation (3.4).

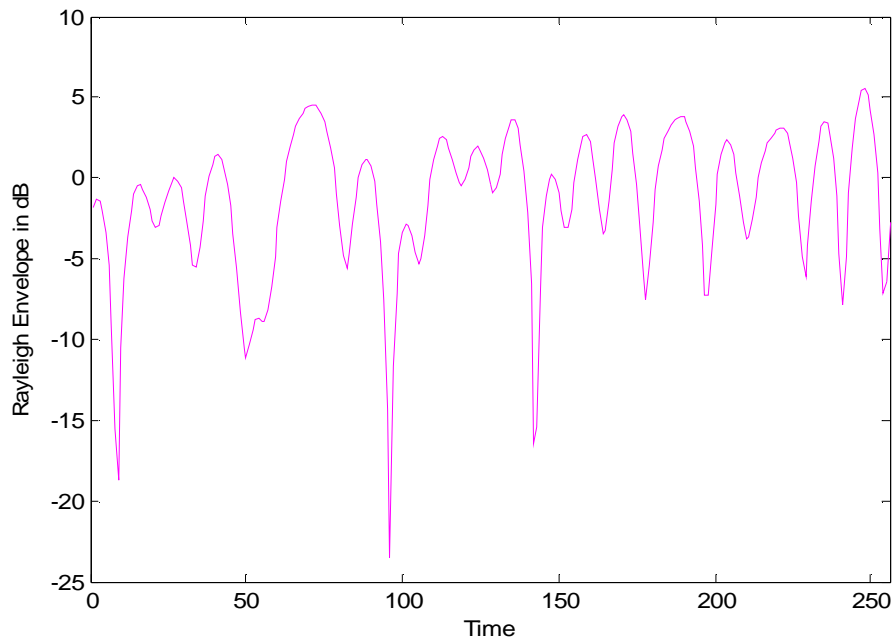

Figure 3.3: Envelope of Rayleigh fading process

⁹ **Central limit theorem**: states that the sum of large number of independent random variables follows the Gaussian distribution.

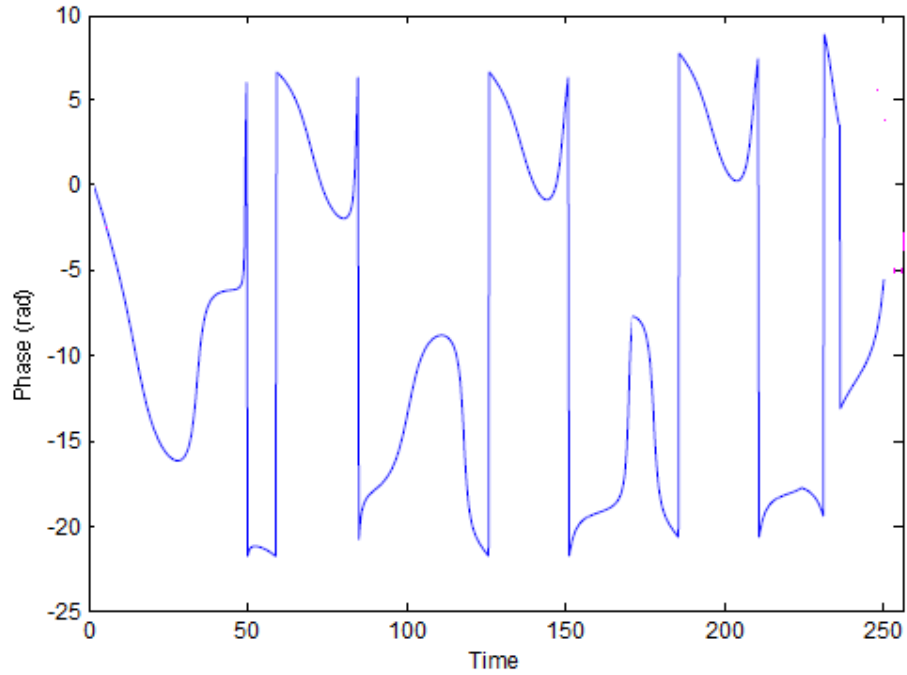

Figure 3.4: Phase of Rayleigh fading process

Since the assumption that each path consists of large number of uncorrelated scatters, and if it's assumed to be wide-sense stationary as suggested by Bello [Bel63], then the autocorrelation function can be written as

$$R_{hh}(\tau) = \sum_{l=1}^{L_s} E[g_{ml}^2] E[e^{j2\pi f_d \tau \cos \phi_{ml}}] \quad (3.7)$$

If the signals arrive at equal probabilities then the autocorrelation function is

$$R_{hh}(\tau) = \sigma_h^2 J_0(2\pi f_d \tau) \quad (3.8)$$

Where J_0 is a zero order Bessel function of the first kind. The autocorrelation function is shown in figure 3.5.

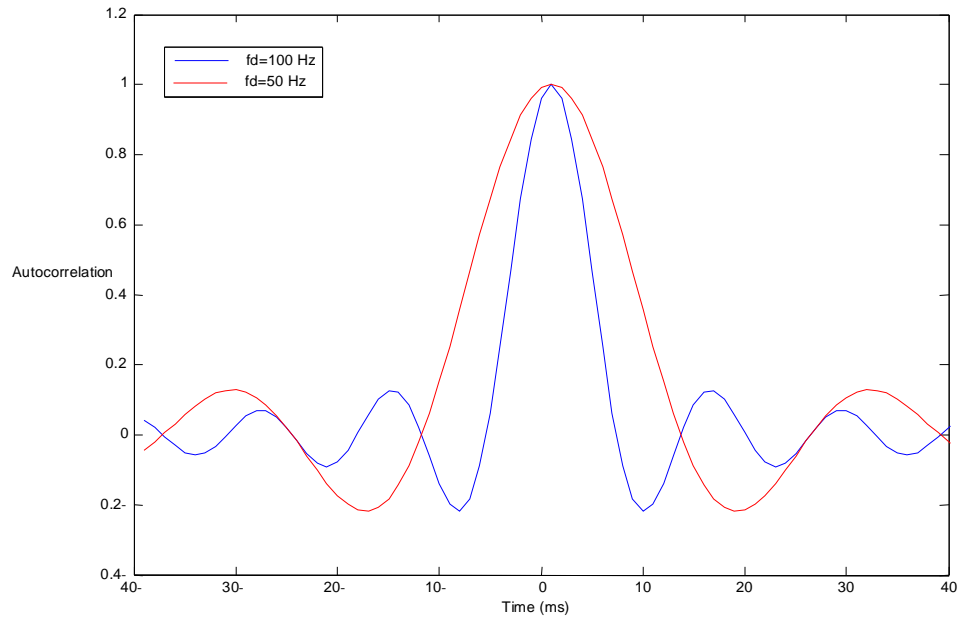

Figure 3.5: The autocorrelation function of the fading channel.

By taking the Fourier transform of the autocorrelation function, a power spectrum density of $h_m(t)$ is obtained. It is band-limited and U-shaped. The shape depends on f_d as shown in Figure 3.6. The Doppler power spectrum is given by [Jak74]

$$\Psi(f) = \begin{cases} \frac{\sigma_h^2}{\pi f_d \sqrt{1 - \left(\frac{f}{f_d}\right)^2}}, & -f_d \leq f \leq +f_d \\ \mathbf{0} & \text{otherwise} \end{cases}, \quad (3.9)$$

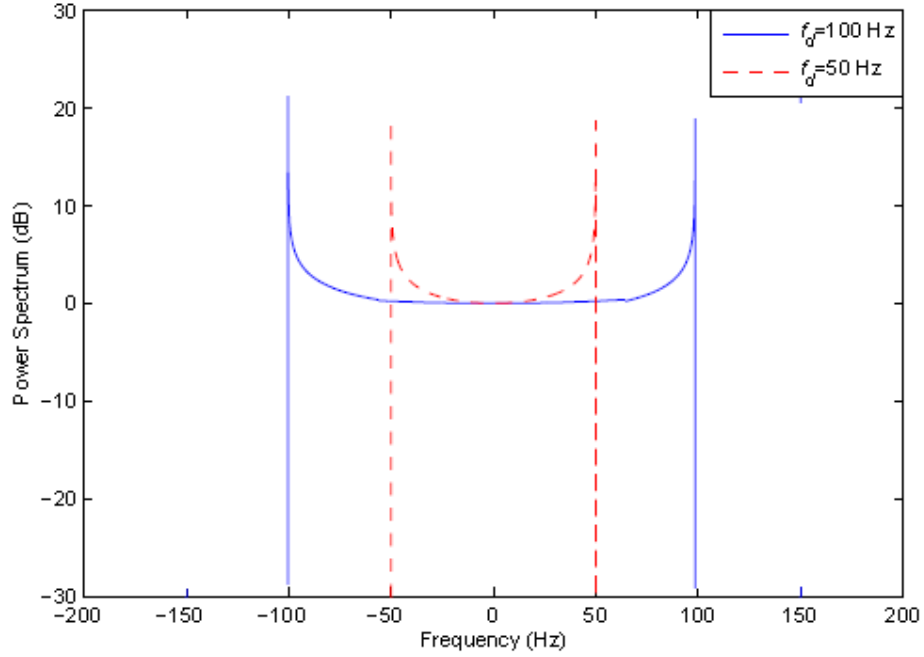

Figure 3.6: The Doppler power spectrum density

By sampling the continuous-time model of the channel at symbol rate $\frac{1}{T_s}$, equation (3.4) can be rewritten as:

$$h_m(n) = \sum_{l=1}^{L_s} g_{ml} e^{j(2\pi f_d T_s n \cos \phi_{ml} + \theta_{ml})} \quad (3.10)$$

The resulting autocorrelation function can be expressed as:

$$R_{hh}(n) = \sigma_h^2 J_0(2\pi f_d T_s |n|) \quad (3.11)$$

where $f_d T_s$ is the Doppler rate.

Now we need a way to simulate the channel according to the previous theoretical description.

3.3 Fading channel modeling

Developing wireless channel models is important for channel simulator that replicates wireless channel data, and produces outputs that vary in a similar manner to the variations encountered in practice. Sum of Sinusoids Simulation Model is an important model but this model is not practical. So Autoregressive model is simple and contains few parameters. These models will be discussed in the next subsections.

3.3.1 Sum of Sinusoids Simulation Model

Jakes in his model derived the sum of sinusoids model to simulate Rayleigh fading channels [Jak74]. In this model, the value of the l th scatter amplitude g_{ml} , the angle of arrival α_{ml} and the initial phase ϑ_{ml} over m th carrier is assumed to be as follows:

$$g_{ml} = \frac{1}{\sqrt{L_s}} \quad (3.12)$$

$$\alpha_{ml} = \frac{2}{\sqrt{L_s}} \quad (3.13)$$

$$\vartheta_{ml} = 0 \quad (3.14)$$

Equations (3.12), (3.13) and (3.14) make the model deterministic and wide-sense non-stationary. A modification on the Jakes model carried out in [Den93] and using Walsh-Hadamard codewords to generate multiple independent fading process. In this model, there is quadrantal symmetry in the magnitude of the Doppler shift. Now to provide quadrantal symmetry for all Doppler shifts leading to equal power oscillators, the following arrival angles are modified as the following:

$$\alpha_{ml} = \frac{2\pi(l - 0.5)}{L_s} \quad (3.15)$$

It follows that:

$$h_m(n) = \sqrt{\frac{2}{L_0}} \sum_{l=1}^{L_0} A_m(l) \cos(2\pi f_d T_s n \cos \alpha_{ml} + \vartheta_{ml}) [\cos \beta_n + i \sin \beta_n] \quad (3.16)$$

The value of the β_n can be expressed as

$$\beta_n = \frac{\pi l}{L_0} \quad (3.17)$$

Where $L_0 = L_s/4$ is the number of oscillators, $A_m(l) = \{\mp 1\}_{l=1,2,\dots,L_0}$ is the m th Walsh-Hadamard codeword and the normalization factor is $\sqrt{\frac{2}{L_0}}$.

The sum-of-sinusoids models can't be used in practice to design channel estimation algorithms due to the following reasons.

1. These models are non-linear.
2. Three parameters need to be defined (α_{ml} , g_{ml} , ϑ_{ml}) for each scatter. This means that we have a very large number of parameters.
3. It is very hard to estimate the parameters of this model.

As an alternative to the sum-of-sinusoids models, AR models will be discussed in the next subsection.

3.3.2 Autoregressive channel modeling

The AR model is simple, linear and contains few parameters that can be easily estimated. It has been used in digital communications [Bad05] [Lin02] where the fading process $h_m(n)$ has been approximated by a p th order AR process, as follows:

$$h_m(n) = \sum_{i=1}^p a_i h_m(n-i) + u_m(n) \quad (3.18)$$

where $\{a_i\}_{i=1,2,\dots,p}$ are the AR model parameters, and $u_m(n)$ denotes the zero-mean complex white Gaussian driving process with variance σ_u^2 over each carrier.

The PSD of the AR(p) process can be expressed as follows [Kay88]:

$$\Psi(f_n) = \frac{\sigma_u^2}{|1 + \sum_{i=1}^p a_i e^{-j2\pi f_n i}|^2} \quad (3.19)$$

where f_n is the normalized frequency.

Now to use the AR model two things have to be investigated:

- 1) The order p of the AR model that play a key rule in approximating the fading channel.
- 2) Defined of both the AR parameters $\{a_i\}_{i=1,2,\dots,p}$ and the driving process variance σ_u^2 .

Determination of the AR parameters

The relationship between the AR parameters and the fading process auto-correlation function is given by the well-known YW equations [Kay88]:

$$\mathbf{R}_{hh} \boldsymbol{\theta} = -\mathbf{r}_h \quad (3.20)$$

where R_{hh} is the fading channel autocorrelation matrix defined:

$$\mathbf{R}_{hh} = \begin{bmatrix} R_{hh}(\mathbf{0}) & R_{hh}(-1) & \dots & R_{hh}(-p+1) \\ R_{hh}(1) & R_{hh}(\mathbf{0}) & \dots & R_{hh}(-p+2) \\ \vdots & \vdots & \ddots & \vdots \\ R_{hh}(p-1) & R_{hh}(p-2) & \dots & R_{hh}(\mathbf{0}) \end{bmatrix} \quad (3.21)$$

$\boldsymbol{\theta}$ is the vector that contains the AR parameters as follows:

$$\boldsymbol{\theta} = \begin{bmatrix} a_1 \\ a_2 \\ \vdots \\ a_p \end{bmatrix} \quad (3.22)$$

$$\mathbf{r}_h = \begin{bmatrix} R_{hh}(1) \\ R_{hh}(2) \\ \vdots \\ R_{hh}(p) \end{bmatrix} \quad (3.23)$$

The variance of the driving process σ_u^2 can be expressed as:

$$\sigma_u^2 = R_{hh}(\mathbf{0}) + \sum_{i=1}^p a_i R_{hh}(-i) \quad (3.24)$$

The order of AR model

Choosing the order p is an important step in modeling the fading process using AR models. Some authors used a low order models as in [Tsa96] [Kom02] since it is simple and the corresponding computational cost is low. Baddour *et al.* [Bad05] use high-order AR processes (e.g., $p \geq 50$) when they simulate the channel. For this purpose, they modify the properties of the channel by considering the sum of the theoretical fading process and a zero-mean white process whose variance very small. Then the AR parameters are estimated with the YWEs based on the modified autocorrelation function

$$R_{hh}^{mod}(n) = J_0(2\pi f_d T_s |n|) + \varepsilon \delta(n) \quad (3.25)$$

Figure 3.7 and Figure 3.8 show the autocorrelation function and the power spectrum density of the Jakes model and that of the fitted AR process whose order is 1, 2, 5 and 20.

As shown that the low order AR processes such as AR(1) and AR(2) provide a poor approximation of the theoretical model. While increasing the model order will provide better approximation.

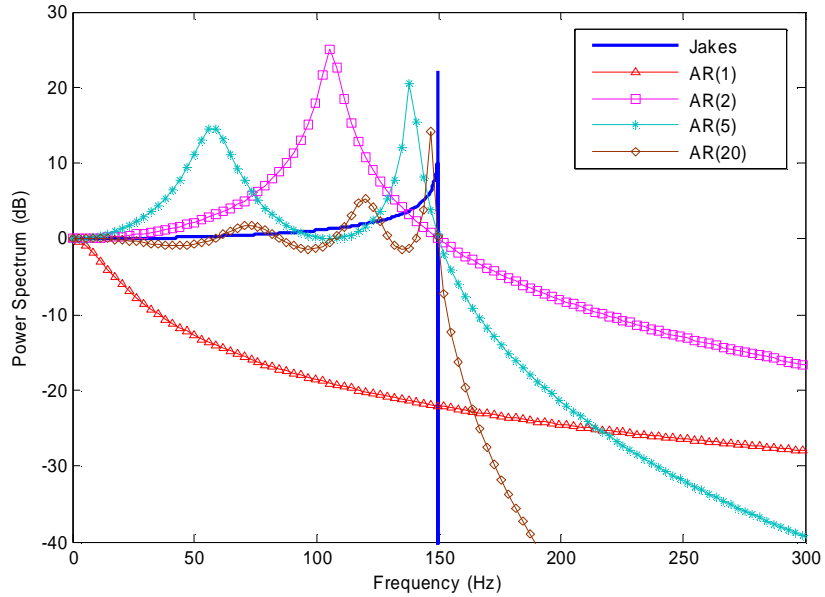

Figure 3.7 Power spectral density of the Jakes model and that of the fitted AR (p) process with $p=1, 2, 5,$ and 20 [Jam07a].

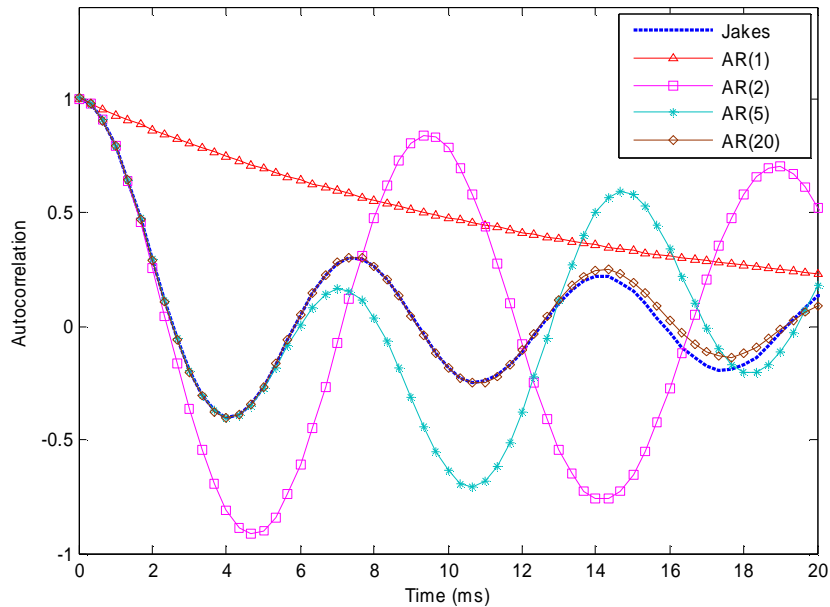

Figure 3.8 Autocorrelation function of the Jakes model and that of the fitted AR (p) process with $p=1, 2, 5,$ and 20 [Jam07a].

Chapter 4

Estimation of Autoregressive OFDM fading channels

Contents

4.1 State of the art	35
4.2 Channel estimator based on the LMS and RLS algorithms	36
4.3 Estimation of the fading process based on Kalman filter	37
4.4 Relevance of the H_∞ filtering for fading process estimation	39
4.5 Two serially connected Kalman or H_∞ filters	42
4.6 Two cross coupled Kalman filters	43
4.6.1 Estimation of the AR parameters.....	43
4.6.2 Estimation of the driving process variance.....	44
4.6.3 Operation of the channel estimator.....	44
4.6.4 Simulation Results.....	45
4.7 Two cross coupled H_∞ filters	48
4.7.1 Estimation of the AR parameters.....	48
4.7.2 Tuning the weighting parameters.....	49
4.7.3 Operation of the channel estimator.....	50
4.7.4 Simulation Results.....	50

4.1 State of the art

OFDM is a parallel data transmission scheme in which high data rates can be achieved by the simultaneous transmission over many orthogonal carriers [Cim85] [Wan00]. This multi-carrier transmission scheme makes it possible to convert the severe wide-band frequency-selective fading channel into many narrow-band frequency non-selective flat fading sub-channels, which are free from ISI.

In OFDM systems, due to user mobility, each carrier is subject to Doppler shifts resulting in time-varying fading. Thus, the estimation of the fading process over each carrier is essential to achieve coherent symbol detection at the receiver. Channel estimation techniques can be classified into three categories:

- a) Training sequence/pilot aided techniques [Ton04].
- b) Blind techniques [Gia98].
- c) Semi-blind techniques [Las03].

In this thesis, we will focus our attention on training based channel estimation techniques. They may be designed with or without a priori modeling of the fading channel. Training sequence/pilot aided techniques estimate the channel from the received noisy signal given known training symbols that are multiplexed with the transmitted data symbols.

Fading channel can be estimated using the *Least Square* (LS) criterion without the need of the priori modelling of the channel. A surveys on the estimation of OFDM fading channel can be found in [Meh07]. A comparison between *Least Mean Square* (LMS) and *Recursive Least Square* (RLS) has been carried in [Kal03]. *Least Minimum Mean Square Error* (LMMSE) is another criterion that widely used in the OFDM channel estimation since it is optimum in minimizing the *Mean Square Error* (MSE) of the channel estimates in the presence of AWGN. LMMSE uses additional information like the operating *Signal to Noise Ratio* (SNR) and the other channel statistics. However, the computational complexity of LMMSE is very high due to extra information incorporated in the estimation technique [Meh07]. The previous estimators do not exploit the channel statistics given by the auto-correlation function and its power spectral density.

AR model can exploit the stochastic properties of the channel. It has been used in many works like [Tsa96] that uses a low order of AR model. On the other hand, Baddour *et al.*

[Bad05] have proposed to use very high-order AR models. [Lin02] proposed a so-called Wiener LMS algorithm that uses a low order AR order to reduce the computational cost. In this chapter and in order to estimate the AR parameters, we propose to take advantage of the two-cross-coupled Kalman filters for the joint estimation of time-varying OFDM fading channels and their corresponding AR parameters and compare it with [Cai04] where two-serially-connected Kalman filters is proposed . In the two-cross-coupled Kalman filters One Kalman filter is used to estimate the fading AR process while the second one makes it possible to estimate the corresponding AR parameters from the estimated fading process. Since Kalman filter has assumptions that must be fulfilled. Moreover, the initial state, the driving process and the measurement noise must be independent, white and Gaussian. However, these assumptions do not always hold in practical cases, especially when dealing with OFDM systems, due to the following uncertainties and approximations:

- 1) AR model does not fit exactly the fading process, especially when considering low-order AR models
- 2) The noise variances in the state space representation and the AR parameters are usually unknown and, hence, must be estimated.

Therefore, H_∞ estimation techniques can be considered. According to these advantages of H_∞ over Kalman we also propose to take advantage of the two-cross-coupled H_∞ filters, initially developed in the framework of speech enhancement [Lab07] for the joint estimation of time-varying OFDM fading channels and their corresponding AR parameters.

4.2 Channel estimator based on the LMS and RLS algorithms

Let us consider an OFDM system with a *Quadrature Phase Shift Keying* (QPSK) modulation schemes. The received signal $r(n)$ can be expressed¹⁰:

$$r(n) = h(n)d(n) + v(n) \tag{4.1}$$

where $h(n)$ is fading process, $d(n) = d_i(n) + jd_q(n)$ for the n -th transmitted bit where $d_i(n)$ and $d_q(n)$ are $\{1,-1\}$ and $v(n)$: Complex AWGN with zero mean and variance σ_v^2

LMS channel estimator provides an estimation $\hat{h}(n)$ of the fading channel $h(n)$ by minimizing the MSE as follows:

$$MSE = E[|r(n) - \hat{h}(n)d(n)|^2] \tag{4.2}$$

¹⁰ Equation (4.1) is equivalent to equation (2.10)

The channel estimate at time $n + 1$ is given by:

$$\hat{h}(n + 1) = \hat{h}(n) + \mu \left(r(n) - \hat{h}(n)d(n) \right) d^*(n) \quad (4.3)$$

where μ is the LMS step size.

RLS channel estimator estimates the fading process by minimizing the cost function [Kal03]:

$$F = \sum_{i=0}^n \lambda^{n-i} |r(i) - h(i)d(i)|^2 \quad (4.4)$$

where λ is the forgetting factor and has a value $0 < \lambda < 1$.

The new channel estimate at time $n + 1$ using the available value at time n can be expressed as:

$$\hat{h}(n + 1) = \hat{h}(n) + \left(r(n) - \hat{h}(n)d(n) \right) K^*(n) \quad (4.5)$$

where the term $K(n)$ is the Kalman gain, given by:

$$K(n) = \frac{P(n)d(n)}{\lambda + P(n)d(n)d^*(n)} \quad (4.6)$$

Then value of $P(n)$ can be expressed as follows:

$$P(n + 1) = \lambda^{-1} \left(1 - K(n)d^*(n) \right) P(n) \quad (4.7)$$

In the so-called training mode, the data symbol $d(n)$ is assumed to be known and available in both the transmitter and the receiver. Kalofonos *et al.* [Kal03] assume that the decisions of the previous data symbols are all correct. The assumption in this work will be the same as in [Kal03] where the estimates of the previous data symbol are all correct (i.e. $d(n) = \hat{d}(n)$).

4.3 Estimation of the fading process based on Kalman filter

Kalman filter estimate the fading process by minimizing the estimation error variance $E \left[|h(n) - \hat{h}(n)|^2 \right]$. For this purpose, first the state vector should be written as follows:

$$\mathbf{h}(n) = [h(n) \quad h(n - 1) \quad \dots \quad h(n - p - 1)]^T \quad (4.8)$$

Given equations (3.18), (4.1) and (4.8), the state space representation of the fading channel system can be written as follows [Jam07a]:

$$\begin{cases} \mathbf{h}(n) = \mathbf{\Phi}(n)\mathbf{h}(n-1) + \mathbf{g}u(n) \\ r(n) = \mathbf{d}^T(n)\mathbf{h}(n) + v(n) \end{cases} \quad (4.9)$$

where

$$\mathbf{\Phi}(n) = \begin{bmatrix} -a_1 & -a_2 & \dots & -a_p \\ \mathbf{1} & \mathbf{0} & \dots & \mathbf{0} \\ \vdots & \ddots & & \vdots \\ \mathbf{0} & \dots & \mathbf{1} & \mathbf{0} \end{bmatrix}$$

is the transition matrix, $\mathbf{g} = [\mathbf{1} \ \mathbf{0} \ \mathbf{0} \ \dots \ \mathbf{0}]^T$ and

the observation vector is $\mathbf{d}^T(n) = [d(n) \ \mathbf{0} \ \dots \ \mathbf{0}]$. The variance of $v(n)$ and $u(n)$ are σ_v^2 and σ_u^2 , respectively. In addition, $v(n)$ and $u(n)$ assumed to be uncorrelated with each other's and with the elements of the initial state vector $\mathbf{h}(\mathbf{0})$.

Hence, equations (4.9) define the state space representation dedicated to the one-carrier fading channel system. At that stage, a standard Kalman filtering algorithm can be carried out to provide the estimation $\hat{\mathbf{h}}(n/n)$ of the state vector $\mathbf{h}(n)$ given the set of observations $\{r(i)\}_{i=1,\dots,n}$ as listed below:

The so-called innovation process $\alpha(n)$ is first obtained:

$$\alpha(n) = r(n) - \mathbf{d}^T(n)\mathbf{\Phi}(n)\hat{\mathbf{h}}(n-1/n-1) \quad (4.10)$$

Its variance is then defined:

$$C(n) = E[\alpha(n)\alpha^*(n)] = \mathbf{d}^T(n)\mathbf{P}(n/n-1)\mathbf{d}(n) + \sigma_v^2 \quad (4.11)$$

where the so-called *a priori* error covariance matrix $\mathbf{P}(n/n-1)$ can be recursively obtained as follows:

$$\mathbf{P}(n/n-1) = \mathbf{\Phi}(n)\mathbf{P}(n-1/n-1)\mathbf{\Phi}^H(n) + \mathbf{g}\sigma_u^2\mathbf{g}^T \quad (4.12)$$

Where $()^H$ denotes the Hermitian operator..

The Kalman gain is calculated in the following manner:

$$\mathbf{K}(n) = \mathbf{P}(n/n-1)\mathbf{d}(n)C^{-1}(n) \quad (4.13)$$

The *a posteriori* estimate of the state vector and the fading process are respectively given by:

$$\hat{\mathbf{h}}(n/n) = \mathbf{\Phi}(n)\hat{\mathbf{h}}(n-1/n-1) + \mathbf{K}(n)\alpha(n) \quad (4.14)$$

and

$$\hat{h}(n/n) = \mathbf{g}^T\hat{\mathbf{h}}(n/n) \quad (4.15)$$

The error covariance matrix is updated as follows:

$$\mathbf{P}(n/n) = \mathbf{P}(n/n-1) - \mathbf{K}(n)\mathbf{d}^T(n) \mathbf{P}(n/n-1) \quad (4.16)$$

It should be noted that the state vector and the error covariance matrix are initially assigned to zero vector and identity matrix respectively, i.e. $\hat{\mathbf{h}}(\mathbf{0}/\mathbf{0}) = \mathbf{0}$ and $\mathbf{P}(\mathbf{0}/\mathbf{0}) = \zeta\mathbf{I}$ where ζ is positive constant, its value mustn't be large to prevent lack of knowledge and not small value that reflecting confidence.

When dealing with the training mode, $\mathbf{d}(n)$ is available, and thus Kalman filter will estimate the $\hat{\mathbf{h}}(n/n)$ of the fading process $h(n)$. Once in the so-called decision-direct mode, the joint estimation for both the fading process $h(n)$ and data sequence $d(n)$ should be carried out. This joint estimation problem can be decomposed into the estimation of the data symbol at time n and then the prediction of the fading process at time $n+1$. So, the prediction $\hat{h}(n+1/n)$ of the fading process $h(n+1)$ can be obtained as follows:

$$\hat{\mathbf{h}}(n+1/n) = \Phi(n) \hat{\mathbf{h}}(n/n) = \Phi(n) \hat{\mathbf{h}}(n/n-1) + \Phi(n)\mathbf{K}(n)v(n) \quad (4.17)$$

$$\hat{h}(n+1) = \hat{h}(n+1/n) = \mathbf{g}^T \hat{\mathbf{h}}(n+1/n) \quad (4.18)$$

Kalman filtering is of interest but it needs several assumptions to be fulfilled, the initial state, the driving process and the measurement noise must be independent, white and Gaussian.

These assumptions may not be satisfied in real cases because:

- a) AR model give an approximate description of the fading channel especially for low order AR models.
- b) AR parameters and noise need to be estimated since these values are unknown.

Therefore, in practical cases, Kalman filter may suffer degradation. The solution is to use H_∞ estimation techniques. H_∞ filtering has several advantages over Kalman filtering [Cai04]:

- 1) No *a priori* knowledge of the noise source statistics is required. (It is assumed only that the noise has finite energy).
- 2) The estimation criterion is to minimize the worst possible effect of the noise distortion on the estimation error.

4.4 Estimation of fading process based on H_∞

The H_∞ theory has been adopted in several areas. However, its applications in signal processing and more particularly in communications are still scarce. Thus, Shen *et al.* [She99] have proposed a speech enhancement approach, where the speech signal is modeled by an AR process. In [Erd00], the authors have proposed to investigate the H_∞ approach to the linear equalization of communication channels. In [Cai04], Cai *et al.* have used the two serially connected H_∞ filter proposed in [She97] to estimate the fading channel in OFDM systems, where the fading channels are modeled by AR processes.

As mention before that the estimation criterion of H_∞ is to minimize the worst possible effects of the noise effects (the initial state, the driving process and the measurement noise) on the estimation error. The H_∞ filter does not require *a priori* knowledge about the noise source statistics. According to Hassibi *et al.* [Has99], H_∞ filtering is more robust against the noise disturbances than Kalman filtering.

H_∞ make it possible not only to estimate the state vector $\mathbf{h}(n)$ but also to estimate a linear combination of the state vector components

$$z(n) = \mathbf{l}\mathbf{h}(n) \quad (4.19)$$

where \mathbf{l} is a $1 \times p$ linear transformation operator. If we want to estimate $\mathbf{h}(n)$ the value of \mathbf{l} is $[\mathbf{1} \ \mathbf{0} \ \dots \ \mathbf{0}]$

By minimizing the H_∞ norm of the transfer operator \mathcal{T} that maps the discrete time noise distributions $w(n), v(n)$ and the initial state error $\mathbf{e}_0 = \mathbf{h}(0) - \hat{\mathbf{h}}(0)$ to the estimation error $e(n) = \mathbf{l}\mathbf{h}(n) - \hat{\mathbf{l}}\mathbf{h}(n)$, H_∞ provide an estimation to $\hat{h}(n) = \hat{\mathbf{l}}\mathbf{h}(n)$ as follows [Cai04]

$$J_\infty = \sup_{u(n), v(n), h(0)} J \quad (4.20)$$

where

$$J = \frac{\sum_{n=0}^{N-1} |e(n)|^2}{\mathbf{e}_0^H \mathbf{P}_0^{-1} \mathbf{e}_0 + \sum_{n=0}^N (Q_u^{-1} |u(n)|^2 + R_v^{-1} |v(n)|^2)} \quad (4.21)$$

where N is number of available data samples, $\mathbf{P}_0 > \mathbf{0}$, $Q_u > \mathbf{0}$ and $R_v > \mathbf{0}$ are weighting parameters and tuned by the designer.

However, a close form solution to equation (3.20) does not always exist. To solve this problem a close suboptimal design strategy is usually considered:

$$J_\infty < \gamma^2 \quad (4.22)$$

where $\gamma > \mathbf{0}$ is prescribed level of disturbance attenuation. The H_∞ estimation may be described as min-max estimation where $\hat{h}(n)$ plays against the distributions $u(n), v(n)$ and the initial state vector $\mathbf{h}(\mathbf{0})$ as follow

$$\begin{aligned} \min_{\hat{h}(n), u(n), v(n), h(\mathbf{0})} \max J &= -0.5 \gamma^2 e_0^H \mathbf{P}_0^{-1} \mathbf{e}_0 \\ &+ 0.5 \sum_{n=0}^N (|e(n)|^2 - \gamma^2 (Q_w^{-1} |w(n)|^2 \\ &+ R_v^{-1} |v(n)|^2) \end{aligned} \quad (4.23)$$

Using the game theory approach [She97] the min-max problem can be solved. According to the game theory there exists H_∞ channel estimator $\hat{h}(n)$ for given $\gamma > \mathbf{0}$ if there exists a stabilizing symmetric positive definite solution $\mathbf{P}(n)$ to the equation

$$\mathbf{P}(n+1) = \mathbf{\Phi}(n) \mathbf{P}(n) \mathbf{C}^{-1}(n) \mathbf{\Phi}(n)^T + \mathbf{g} Q_w \mathbf{g}^T, \quad \mathbf{P}(\mathbf{0}) = \mathbf{P}_0 \quad (4.24)$$

where

$$\mathbf{C}(n) = \mathbf{I}_p - \gamma^{-2} \mathbf{l}^T \mathbf{l} \mathbf{P}(n) + \mathbf{d}(n) R^{-1} \mathbf{d}^T(n) \mathbf{P}(n) \quad (4.25)$$

This leads to the following condition:

$$\mathbf{P}(n) \mathbf{C}^{-1}(n) > \mathbf{0} \quad (4.26)$$

If the condition in (20) is true, then the H_∞ estimator exists and can be written as follows:

$$\hat{h}(n) = \mathbf{l} \hat{\mathbf{h}}(n) \quad (4.27)$$

$$\hat{\mathbf{h}}(n) = \mathbf{\Phi}(n) \hat{\mathbf{h}}(n-1) + \mathbf{K}(n) \alpha(n), \quad \hat{\mathbf{h}}(\mathbf{0}) = \mathbf{0} \quad (4.28)$$

where

$$\alpha(n) = r(n) - \mathbf{d}^T(n) \mathbf{\Phi}(n) \hat{\mathbf{h}}(n-1) \quad (4.29)$$

and $\mathbf{K}(n)$ is the gain of H_∞ and defined as

$$\mathbf{K}(n) = \mathbf{P}(n) \mathbf{C}^{-1}(n) \mathbf{d}(n) R_v^{-1} \quad (4.30)$$

The parameter γ should be carefully selected to satisfy equation (4.24) as follows [Cai04]:

$$\gamma^2 > \max\{eig[\mathbf{Q}(\mathbf{P}^{-1} + \mathbf{C}^T \mathbf{V}_H^{-1} \mathbf{C})^{-1}]\} \quad (4.31)$$

H_∞ estimator has the same structure as Kalman, but equation (3.25) increase the computational cost. If the value of Q_u , R_v and \mathbf{P}_o chosen to be σ_u^2 , σ_v^2 and initial error covariance matrix of $\mathbf{h}(\mathbf{0})$ of $\gamma \rightarrow +\infty$, then H_∞ estimator became Kalman filter estimator. However, equations (4.10)-(4.16) can be carried out providing the AR parameters that are involved in the transition matrix $\Phi(n)$ and the driving process variance s_u^2 are both available. But in real case as mention these values are unknown. Hence the AR parameters and the driving process need to be estimated.

4.5 Two serially connected filters

Estimation the AR parameters was discussed by many authors [Tsa96] [Cai04]. Tsatsanis *et al* use the Yule-Walker estimator.

In [Cai04], a two-serially connected Kalman or H_∞ filter based estimator was proposed to estimate a fading channel in OFDM system See Figure 4.1.

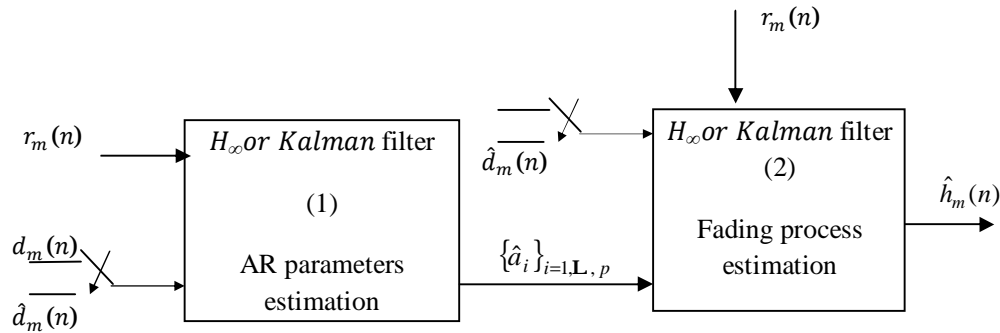

Figure 4.1: Two serially connected Kalman filter for an estimation of the fading process and its AR parameters along the m th carrier.

The first one is used for AR parameter estimation and the second one for fading process estimation. The AR parameters are directly estimated from the available noisy observations as follows:

Let the AR parameters vector is

$$\mathbf{a} = [-a_1 \quad -a_2 \quad \dots \quad -a_p]^T \quad (4.32)$$

$$\hat{\mathbf{a}}(n) = \hat{\mathbf{a}}(n-1) + \mathbf{K}(d(n) - \mathbf{d}(n)\hat{\mathbf{a}}(n-1)), \hat{\mathbf{a}}(\mathbf{0}) = \mathbf{0} \quad (4.33)$$

The value of \mathbf{K} is then obtain from the equation (4.24), (4.25) and (4.30).

From the estimated AR parameters, an estimation of the fading process is then carried out.

4.6 Two cross coupled Kalman filters

In this thesis, we propose to take advantage of the two-cross-coupled Kalman filters for the joint estimation of time-varying OFDM fading channels and their corresponding AR parameters. See Fig. 4.2.

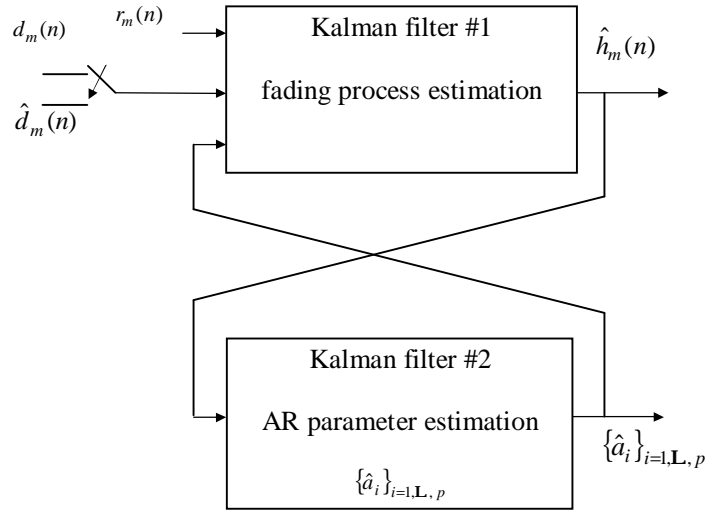

Figure 4.2 Two-cross-coupled Kalman filter based structure for the joint estimation of the fading process and its AR parameters along the m th carrier.

4.6.1 AR parameters estimation

To estimate the AR parameters from the estimated fading process $\hat{h}(n)$, equations (4.14) and (4.15) are firstly combined to express the estimated fading process as a function of the AR parameters:

$$\begin{aligned}\hat{\mathbf{h}}(n) &= \mathbf{g}^T \boldsymbol{\Phi}(n) \hat{\mathbf{h}}(n-1) + \mathbf{g}^T \mathbf{K}(n) \boldsymbol{\alpha}(n) \\ &= \hat{\mathbf{h}}^T(n-1) \mathbf{a}(n) + v(n)\end{aligned}\quad (4.34)$$

where $\hat{\mathbf{h}}(n-1) = [\hat{h}(n-1) \ \hat{h}(n-2) \ \dots \ \hat{h}(n-p)]^T$ and $\mathbf{a}(n)$ as in (4.32). In addition, the variance of the process $v(n) = \mathbf{g}^T \mathbf{K}(n) \boldsymbol{\alpha}(n)$ is given by:

$$\sigma_v^2(n) = \mathbf{g}^T \mathbf{K}(n) \mathbf{C}(n) \mathbf{K}^H(n) \mathbf{g} \quad (4.35)$$

When the channel is assumed stationary, the AR parameters are time-invariant and satisfy the following relationship:

$$\mathbf{a}(n) = \mathbf{a}(n-1) \quad (4.36)$$

As (4.34) and (4.36) define a state space representation for the estimation of the AR parameters, a second Kalman filter can be used to recursively estimate $\mathbf{a}(n)$ as follows:

$$\hat{\mathbf{a}}(n) = \hat{\mathbf{a}}(n-1)\mathbf{K}_a(n)(\hat{h}(n) - \hat{\mathbf{h}}^T(n-1)\hat{\mathbf{a}}(n)) \quad (4.37)$$

where the Kalman gain $\mathbf{K}_a(n)$ and the update of the error covariance matrix $\mathbf{P}_a(n)$ are respectively given by:

$$\mathbf{K}_a(n) = \mathbf{P}_a(n-1)\hat{\mathbf{h}}^*(n-1)(\hat{\mathbf{h}}^H(n-1)\mathbf{P}_a(n-1)\hat{\mathbf{h}}(n-1) + \sigma_v^2(n))^{-1} \quad (4.38)$$

$$\mathbf{P}_a(n) = \mathbf{P}_a(n-1) - \mathbf{K}_a(n)\hat{\mathbf{h}}^T(n-1)\mathbf{P}_a(n-1) \quad (4.39)$$

with initial conditions $\hat{\mathbf{a}}(\mathbf{0}) = \mathbf{0}$ and $\mathbf{P}_a(\mathbf{0}) = \mathbf{I}_p$.

Note that according to (4.35) and (4.38), the variance of the innovation process of the first Kalman filter is used to drive the Kalman gain of the second.

4.6.2 Estimation of the Driving Process Variance

To estimate the driving process variance σ_u^2 , the Riccati equation is first obtained by inserting (4.12) in (4.16) as follows:

$$\mathbf{P}(n/n) = \Phi(n)\mathbf{P}(n-1/n-1)\Phi^H(n) + \mathbf{g}\sigma_u^2\mathbf{g}^T - \mathbf{K}(n)\mathbf{d}^T(n)\mathbf{P}(n/n-1) \quad (4.40)$$

Taking into account that $\mathbf{P}(n/n-1)$ is a symmetric Hermitian matrix, one can rewrite (4.13) in the following manner:

$$\mathbf{b}^T(n)\mathbf{P}(n/n-1) = \mathcal{C}(n)\mathbf{K}^H(n) \quad (4.41)$$

By combining (4.38) and (4.39), σ_u^2 can be expressed as follows:

$$\sigma_u^2 = \mathbf{f}[\mathbf{P}(n/n) - \Phi(n)\mathbf{P}(n-1/n-1)\Phi^H(n) + \mathbf{K}(n)\mathcal{C}(n)\mathbf{K}^H(n)]\mathbf{f}^T \quad (4.42)$$

where $\mathbf{f} = [\mathbf{g}^T\mathbf{g}]^{-1}\mathbf{g}^T = \mathbf{g}^T$ is the pseudo-inverse of \mathbf{g} .

Thus, we propose to estimate σ_u^2 recursively as follows:

$$\begin{aligned} \hat{\sigma}_u^2(n) &= \lambda\hat{\sigma}_u^2(n) \\ &\quad + (1-\lambda)\mathbf{f}[\mathbf{P}(n/n) - \Phi(n)\mathbf{P}(n-1/n-1)\Phi^H(n) \\ &\quad + \mathbf{K}(n)|\alpha(n)|^2\mathbf{K}^H(n)]\mathbf{f}^T \end{aligned} \quad (4.43)$$

where the variance of the innovation process $\mathcal{C}(n)$ is replaced by its instantaneous value $|\alpha(n)|^2$ and λ is the forgetting factor. It should be noted that λ can be either constant or time-varying (e.g., $\lambda(n) = (n-1)/n$).

4.6.3 Operation of the channel estimator

During the training mode, the first Kalman filter uses the training sequence $d_m(n)$, the observation $r_m(n)$ and the latest estimated AR parameters $\{\hat{a}_i\}_{i=1,\dots,p}$ to estimate the fading process $h_m(n)$; while the second Kalman filter uses the estimated fading process $\hat{h}_m(n)$ to update the AR parameters. At the end of the training period, the receiver stores the estimated AR parameters and uses them in conjunction with the observation $r_m(n)$ and the decision $\hat{d}_m(n)$ to predict $h_m(n+1)$ in a decision directed manner. It should be noted that a prediction version of the Kalman filtering algorithm (4.10) – (4.16) must be used in the decision directed mode.

At the receiver, the received signal is multiplied by the conjugate of the channel estimate to compensate for the phase offset introduced by the fading channel, and the data symbols are recovered by coherent detection.

4.6.4 Simulation Results

In this section, a comparative simulation study was carried out on the estimation of OFDM fading channels between the two-cross-coupled Kalman filter and other estimators based on LMS or RLS algorithms. Let us consider an OFDM with QPSK modulation, 52 carriers, and a central carrier frequency of 1900 MHz. The transmitted frame size over each carrier is assumed to be 256 symbols. The fading processes $\{h_m(n)\}_{m=1,\dots,M}$ are generated according to the modified Jakes model [Den93] with 16 distinct oscillators and Doppler rate $f_d T_s = 0.097$. They are normalized to have a unit variance, i.e. σ_h^2 . The average *Signal-to-Noise Ratio* (SNR) per carrier is defined by:

$$SNR = 10 \log_{10} \left(\frac{\sigma_h^2}{\sigma_u^2} \right) = 10 \log_{10} \left(\frac{1}{\sigma_u^2} \right) \quad (4.44)$$

Figure 4.3 shows the estimation of AR (2) parameters. YW equation provides the true value of these parameters. The true values are:

$$a_1 = -1.7627, a_2 = 0.9503$$

Figure 4.3 shows that the AR parameters go to the truth value after 150 samples.

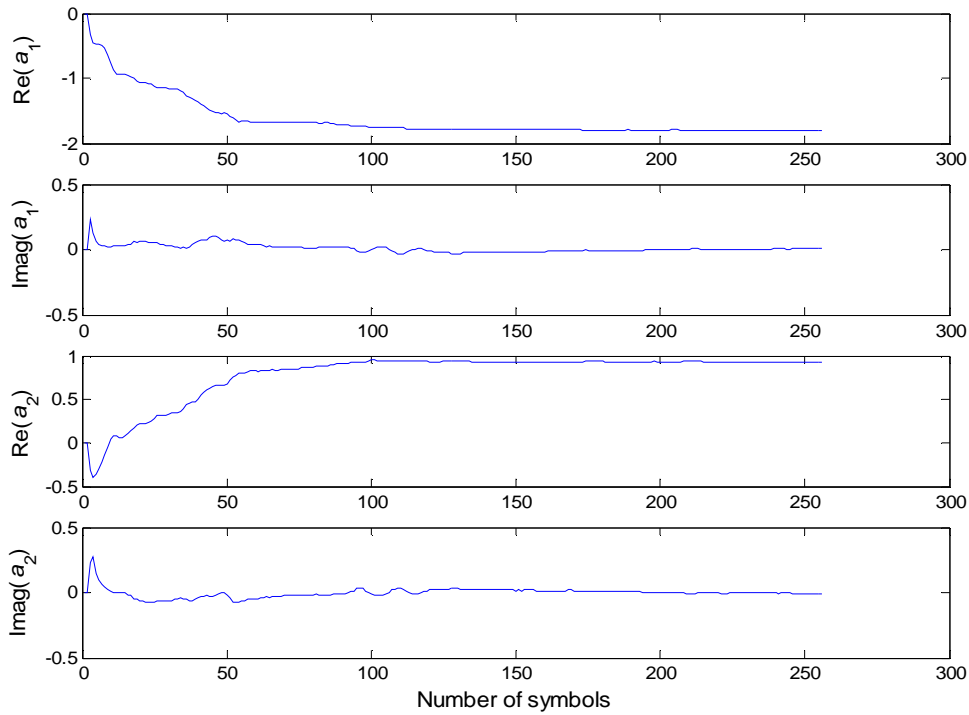

Figure 4.3 Real and imaginary parts of the estimated AR(2) parameters using two-cross-coupled Kalman filters

Figure 4.4 and Figure 4.5 show the Mean Square Error (MSE) of the estimated fading process and the BER performance of the OFDM system when using the various channel estimators. One can notice that the two cross coupled Kalman filters provide significant performance improvement over the LMS and RLS estimation. Increasing the order of the AR model will also give more accurate results. Although the amount of improvement between AR(1) and AR(2) is significant, the amount of improvement beyond AR(5) is not so much. Although high-order AR models (e.g., AR(20)) can provide better modeling approximation than low-order AR models (see Figure 3.5 and Figure 3.6), the amount of performance improvement in that case is small compared with the resulting computational cost $O(p^3)$ of the estimation algorithm. Therefore, and according to [Jam07b] and [Wal06], an AR(5) is recommended to reduce the computational cost.

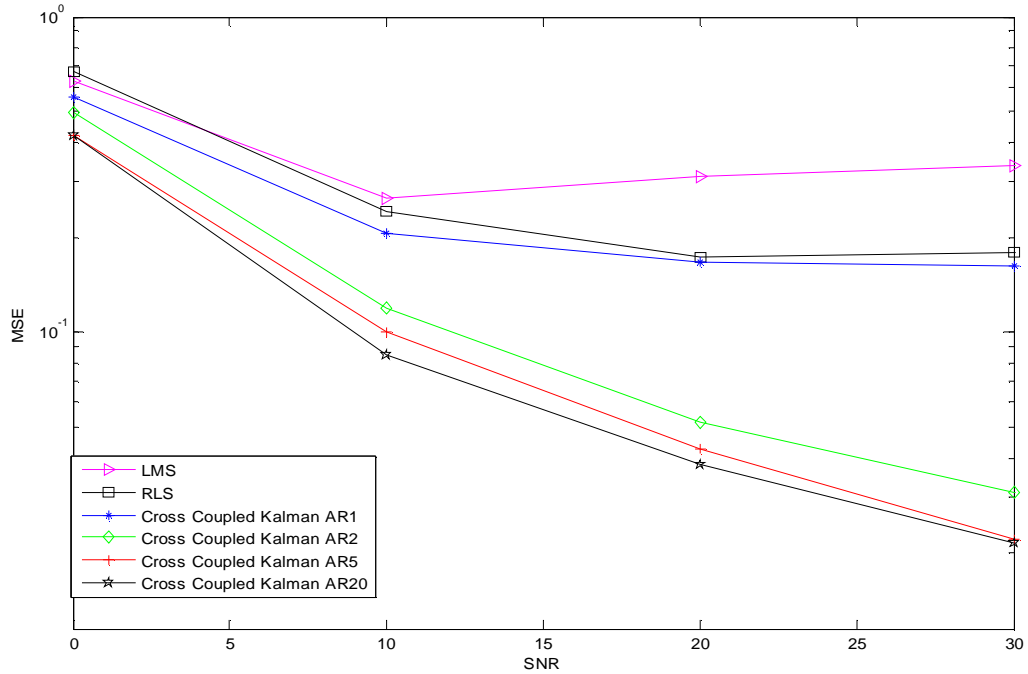

Figure 4.4 MSE versus SNR of the OFDM system with the various channel estimators.

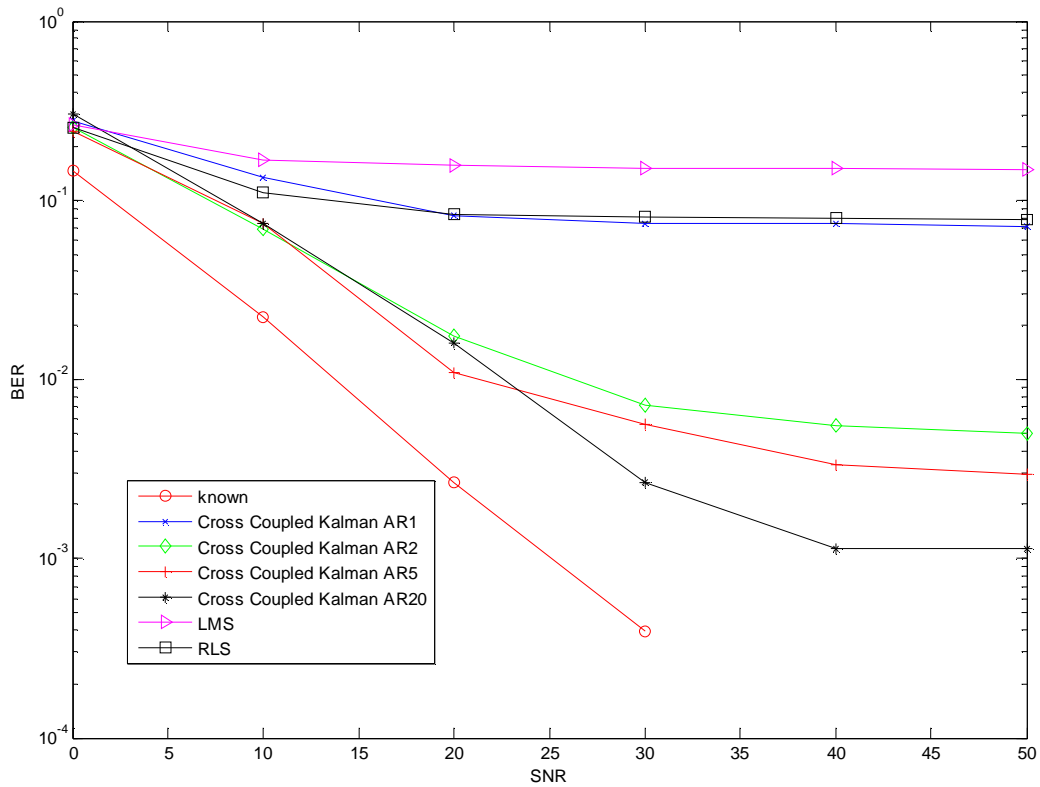

Figure 4.5 BER performances versus SNR of the OFDM system with the various channel estimators.

4.7 Two crossed Coupled H_∞ in Filtering

As mention before that Kalman need more assumptions, but using H_∞ lead us to a more robust system. Hence, we propose to take advantage of the two-cross-coupled H_∞ filters [Lab07] as shown in Figure.4.6. for the joint estimation of time-varying OFDM fading channels and their corresponding AR parameters, and to compare the solution with the two-serially H_∞ filtering proposed by Cai *et al* [Cai04] and two cross coupled Kalman filters. Low and high order AR models are investigated.

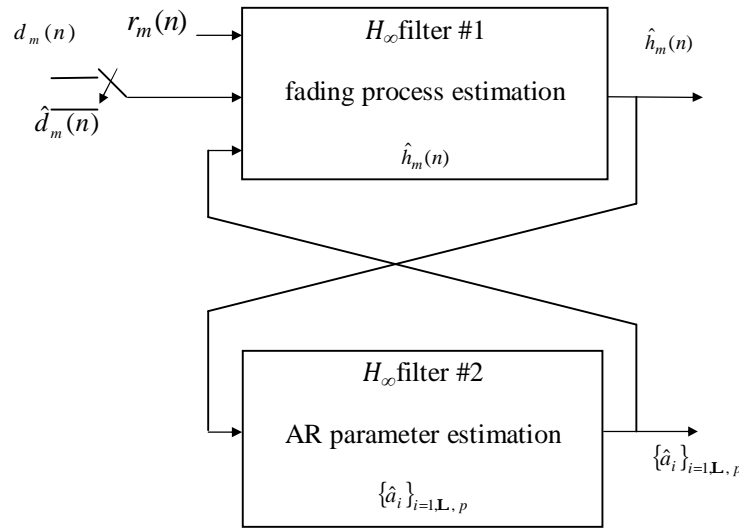

Figure 4.6 Two-cross-coupled H_∞ filters.

4.7.1 AR parameters estimation

To estimate the AR parameters from the estimated fading process $\hat{h}(n)$, equations (4.27) and (4.28) combined to express the estimated fading process as a function of the AR parameters to get a result:

$$\hat{h}(n) = \hat{\mathbf{h}}(n-1) \boldsymbol{\theta}(n) + w(n) \quad (4.45)$$

where $\boldsymbol{\theta}(n) = [-a_1 \ -a_2 \ \dots \ -a_p]$ is the AR parameters vector, $w(n) = \mathbf{I}\mathbf{K}(n)\alpha(n)$.

Assume that the channel is stationary then

$$\boldsymbol{\theta}(n) = \boldsymbol{\theta}(n-1) \quad (4.46)$$

Now the state space representation described in equation (4.45) and (4.46). Defining the estimation error as

$e_\theta = \hat{\mathbf{h}}^T(n-1)\boldsymbol{\theta}(n) - \hat{\mathbf{h}}^T(n-1)\hat{\boldsymbol{\theta}}(n)$. Then the second H_∞ can recursively estimate $\boldsymbol{\theta}(n)$ as follows:

$$\hat{\boldsymbol{\theta}}(n) = \hat{\boldsymbol{\theta}}(n-1) + \mathbf{K}_\theta(n)\alpha_\theta(n) \quad \hat{\boldsymbol{\theta}}(0) = \mathbf{0} \quad (4.47)$$

Where $\alpha_\theta(n)$ is given by:

$$\alpha_\theta(n) = \hat{h}(n) - \hat{\mathbf{h}}^T(n-1)\hat{\boldsymbol{\theta}}(n-1) \quad (4.48)$$

The gain $\mathbf{K}_\theta(n)$ is expressed as follows:

$$\mathbf{K}_\theta(n) = \mathbf{P}_\theta(n)\mathbf{C}_\theta^{-1}(n)\hat{\mathbf{h}}(n-1)\mathbf{R}_u^{-1} \quad (4.49)$$

where the $\mathbf{C}_\theta(n)$ is:

$$\begin{aligned} \mathbf{C}_\theta(n) = & \mathbf{I}_p - \gamma_\theta^{-2}\hat{\mathbf{h}}(n-1)\hat{\mathbf{h}}^H(n-1)\mathbf{P}_\theta(n) \\ & + \hat{\mathbf{h}}(n-1)\mathbf{R}_w^{-1}\hat{\mathbf{h}}^H(n-1)\mathbf{P}_\theta(n) \end{aligned} \quad (4.50)$$

The covariance error $\mathbf{P}_\theta(n+1)$ is given by:

$$\mathbf{P}_\theta(n+1) = \mathbf{P}_\theta(n)\mathbf{C}_\theta^{-1}, \quad \mathbf{P}_\theta(0) = \mathbf{P}_{\theta_0} \quad (4.51)$$

where $\mathbf{R}_w > \mathbf{0}$ and $\mathbf{P}_{\theta_0} > \mathbf{0}$ are weighting parameters. And $\gamma_\theta > \mathbf{0}$ is the disturbance attenuation level and must satisfy

$$\gamma_\theta^2 > \max\left(\text{eig}\left[\mathbf{l}^T\mathbf{l}[\mathbf{P}^{-1}(n) + \mathbf{d}(n)\mathbf{R}_v^{-1}\mathbf{d}^T(n)]\right]\right) \quad (4.52)$$

4.7.2 Tuning the weighting parameters

According to *Cai* [Cai04], the weighting parameters Q_u , and R_v are chosen as the driving process and the additive sequence respectively ($Q_u = \sigma_u^2$ and $R_v = \sigma_v^2$). By analogy with kalman filter theory, the weighting parameters can recursively tuned as in [Lab06]

$$\hat{Q}_u(\mathbf{n}) = \lambda \hat{Q}_u(n-1) + (1-\lambda)\mathbf{f}\mathbf{M}(n)\mathbf{f}^T \quad (4.53)$$

where $\mathbf{M}(n) = \mathbf{P}(n) - \boldsymbol{\Phi}\mathbf{P}(n)\boldsymbol{\Phi}^T + \mathbf{K}(n)|\alpha(n)|^2\mathbf{K}^H(n)$, $\mathbf{f} = [\mathbf{1} \ \mathbf{0} \ \mathbf{0} \ \dots \ \mathbf{0}]$ and λ is the forgetting factor.

The value of \mathbf{R}_w assigned as

$$\mathbf{R}_w = \mathbf{I}\mathbf{K}(n)|\alpha(n)|^2\mathbf{K}^H(n)\mathbf{I}^T \quad (4.54)$$

Finally the value of \mathbf{P}_0 and \mathbf{P}_{θ_0} are chosen to equal the identity matrix (\mathbf{I}_p)

4.7.3 Operation of the channel estimator

During the so-called training mode, the first H_∞ filter uses the training sequence $d_m(n)$, observation $r_m(n)$ and the latest estimated AR parameters $\{\hat{a}_i\}_{i=1,\dots,p}$ to estimate the fading process $h_m(n)$; while the second H_∞ filter uses the estimated fading process $\hat{h}_m(n)$ to update the AR parameters. At the end of the training period, the receiver stores the estimated AR parameters and uses them in conjunction with the observation $r_m(n)$ and the decision $\hat{d}_m(n)$ to predict $h_m(n+1)$ in a decision directed manner.

The procedure at the receiver is the same as procedure mention in the operation of two-cross-coupled Kalman filter.

4.7.4 Simulation Results

Figure 4.7 illustrates the BER of the estimated fading process and the performance of the OFDM system where the order is 2 and 5, the Doppler rate $f_d T_b = 0.0916$ and SNR=30 dB. One can notice that the two-cross-coupled H_∞ filter based approach yields much lower BER than the two- serially connected H_∞ filter based one. One can notice that the two-cross-coupled H_∞ filter based approach yields much lower BER than the two- serially connected H_∞ filter based one.

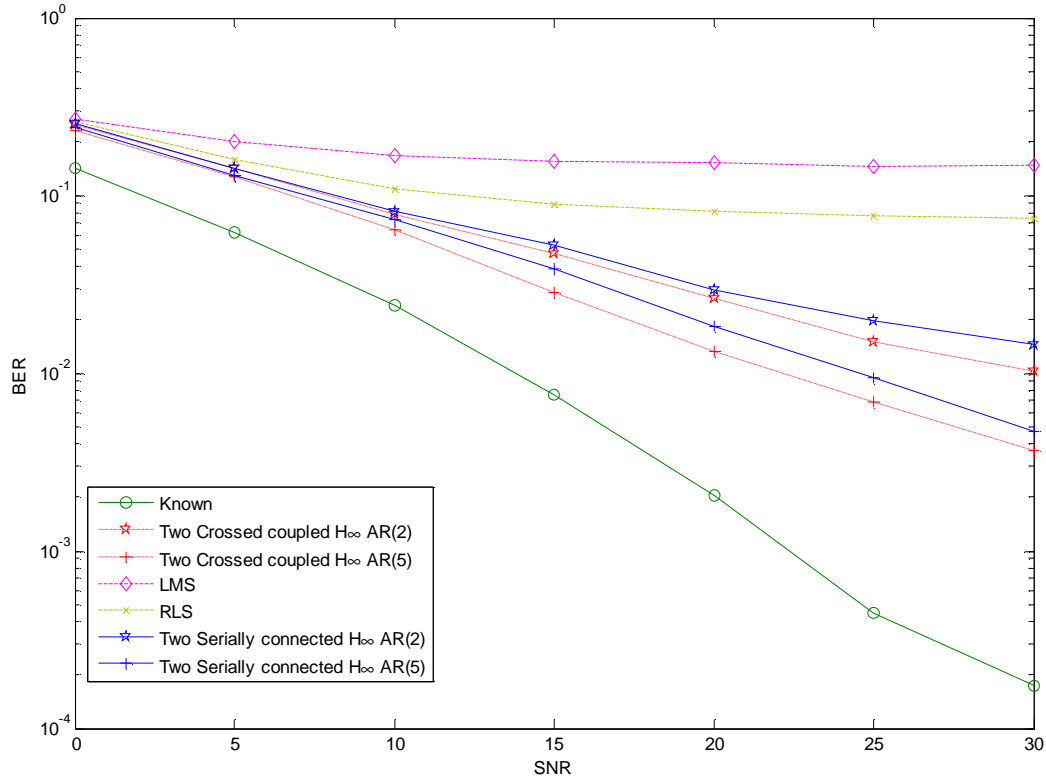

Figure 4.7: BER performance versus SNR of the OFDM system. The AR model order is $p=2$ and $p=5$

According to Figure 4.8, the two-cross-coupled H_∞ filter based estimator provides approximately the same estimation as the two-cross-coupled Kalman filter. Based on the various simulation tests we have carried out using AR models with order $p=1, 2, 5$ and 20 , we got approximately the same results for both Kalman and H_∞ filter based estimator. Therefore, although the two-cross-coupled H_∞ filter based approach does not provide better results than the two-cross-coupled Kalman filter based one; it has the advantage of relaxing the Gaussian and white assumptions required by Kalman filtering.

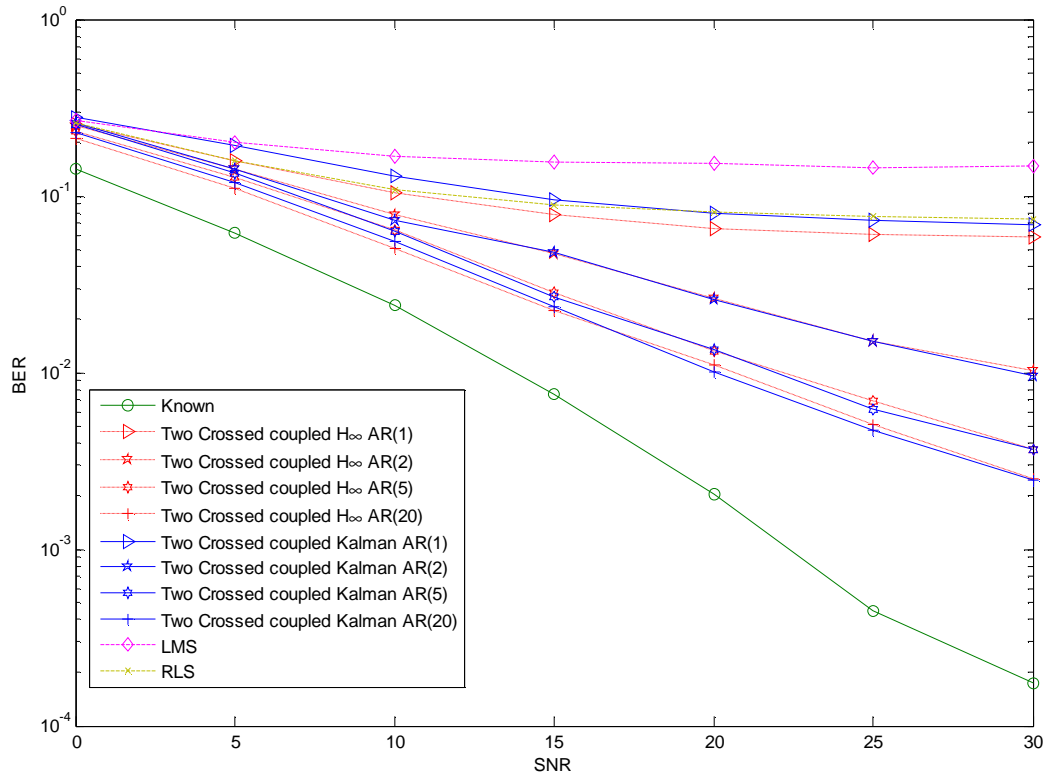

Figure 4.8: BER versus SNR of the OFDM system with the various channel estimators with AR order 1, 2, 5 and 20.

Figure 4.9 show the estimation of the AR parameters. One can notice that these values go to the truth value $a_1 = -1.7627$, $a_2 = 0.9503$ after 150 samples.

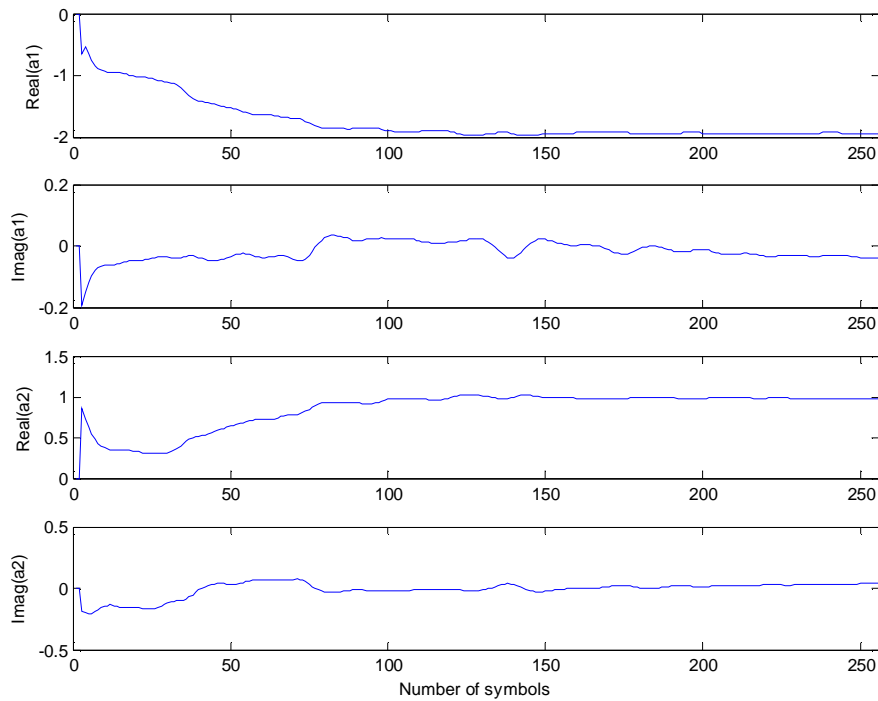

Figure 4.9 Real and imaginary parts of the estimated AR(2) parameters using two-cross-coupled H_∞ filter

Graphical User Interface:

To simplify using OFDM system a simulation program is built using the GUI in MATLAB program as shown in Appendix C at the end of the thesis. The GUI simulation can make a comparison between the proposed filters in this research and show the results in a figure. There are three types of output figures and to choose any of them just to click on the check point. This GUI simulation makes it easier for users to simulate the OFDM system than using codes.

Chapter 5

Conclusion and Future Work

Contents

Conclusion.....	55
Future Work.....	55

Conclusion

OFDM is an efficient parallel data transmission scheme, where high data rate can be achieved by the simultaneous transmission over many carriers. OFDM converts the frequency selective fading channel into flat fading sub-channels that are free of ISI.

In this thesis, the estimation of rapidly time-varying OFDM fading channels is investigated. Two-cross-coupled Kalman filter is considered for the joint estimation of the fading process and the corresponding AR parameters over each carrier. To avoid the restrictive Gaussian assumptions required by Kalman filtering, we also investigate the relevance of two-cross-coupled H_∞ filter based channel estimator. The comparative simulation study is carried out with the conventional LMS and RLS channel estimators shows that the two-cross-coupled Kalman filter based channel estimator can provide significant results over the LMS and RLS ones. In addition, the proposed two-cross-coupled H_∞ filter based channel estimator shows a better performance over the one based on two-serially-connected H_∞ filters, and provides approximately the same estimates as the two-cross-coupled Kalman filter based estimator but without the need of any assumptions needed by Kalman filters.

Future Work

The reader of this thesis can find many topics to be studied for example:

1) Estimation the fading channel of a multi-users OFDM system (OFDMA):

Figure 5.1 shows the multi-user version of OFDM. OFDMA assigns subsets of subcarriers to individual users. This is done based on the information about the channel condition, where the adaptive user-to-subcarrier assignment can be achieved. Different number of sub-carriers can be assigned to different users where the research is to control the data rate and error probability individually for each user and estimate the fading channel [Yoo06].

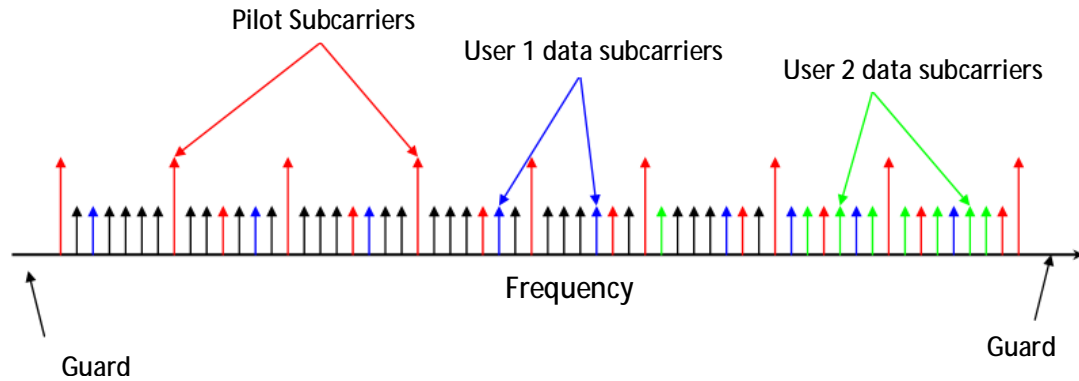

Figure 5.1: OFDMA

2) Investigate channel estimators based on pilot sequence:

The channel estimation can be performed by either inserting pilot tones into all of the subcarriers of OFDM symbols with a specific period or inserting pilot tones into each OFDM symbol [Col02]. For more information about the estimation when a pilot sequence is investigated, see [Yeh02].

3) Carrier frequency offset estimation in OFDM systems

One of the problems in OFDM system is the mismatch of the oscillators in the transmitter and the receiver. The demodulation of a signal with an offset in the carrier frequency can cause a high bit error rate and may degrade the performance of a symbol synchronizer [Jan97]. Kam *et.al.* [Kam93] proposed to use A planar extended Kalman filter for estimating frequency offset. It is an important field for search [Mor07].

Acronyms and Abbreviations

1G:	First Generation
2G:	Second Generation
3G :	Third Generation
ADSL:	Asynchronous Digital Subscriber Lines
AMPS:	Advanced Mobile Phone Service
AR:	Auto-Regressive
AT&T:	American Telephone and Telegraph
AWGN:	Additive White Gaussian Noise
B3G:	Beyond 3G
BWA:	Broadband Wireless Access
CDMA:	Code Division Multiple Access
CEPT:	Conference of European Postal and Telecommunications administrations
DAB:	Digital Audio Broadcasting
DFT:	Discrete Fourier Transform
DMT:	Discrete Multi-Tone
DVB:	Digital Video Broadcasting
EDGE:	Data rate for GSM Evolution
EM:	Expectation-Maximization
FFT:	Fast Fourier Transform
FDD:	Frequency Division Duplex
FDMA:	Frequency Division Multiple Access
GPRS :	General Packet Radio Service
GSM:	Global System for Mobile communications
HDSL:	High-bit-rate Digital Subscriber Lines
IDEN:	Integrated Digital Enhanced Network
IFFT:	Inverse Fast Fourier Transform

Acronyms and abbreviations

IMT-2000:	International Mobile Telecommunications
IS-95:	Interim Standard-95
ISI:	Inter-Symbol Interference
ITU:	International Telecommunication Union
LS:	Least Square
LMS:	Least Mean Square
LMMSE:	Least Minimum Mean Square Error
MCM:	Multi-Carrier Modulation
MSE:	Mean Square Error
NMT:	Nordic Mobile Telephony
NTT:	Nippon Telephone and Telegraph
OFDM:	Orthogonal Frequency Division Multiplexing
PDC:	Personal Digital Cellular
QPSK:	Quadrature Phase Shift Keying
RLS:	Recursive Least Square
SNR:	Signal to Noise Ratio
TDD:	Time Division Duplex
TDMA:	Time Division Multiple Access
VHDSL:	Very High-speed Digital Subscriber Lines
Wi-Fi:	Wireless Fidelity
WiMAX:	Worldwide Interoperability for Microwave Access
WSSUS:	Wide-Sense Stationary Uncorrelated Scattering
YWE:	Yule-Walker Equations

Notations

$h(t)$: Fading channel

L_p : Number of paths

L_s : Number of uncorrelated scatters

$\varphi_l(t)$ is the time varying phase

f_D is the Doppler shift

g_{ml} , Amplitude of the l th scatter and m th carrier

φ_{ml} : Angle of arrival of the l th scatter and m th carrier

θ_{ml} Initial phase of the l th scatter and m th carrier

R_{hh} : Auto correlation matrix

$E[.]$: Expectation

J_0 : Zero order Bessel function

$\delta(.)$: Delta function

$(.)^*$: Complex conjugate

$(.)^T$: Transpose

v : Speed of the mobile

f_c :Carrier frequency

T_s : Symbol period

T_g :Guard interval

M : Number of carriers

$y(t)$: Transmitted OFDM signal

$A_m(l) = \{\mp 1\} l = 1, 2, \dots, L_0$: the m th Walsh-Hadamard codeword

$\{a_i\}_{i=1, \dots, p}$: AR parameters

$d_{k,q}$: The output of FFT of q -th subcarrier with k -th symbol

$r(n)$: Received OFDM signal

$\hat{h}(n)$: Estimated fading process

μ : is the LMS step size

λ : is forgetting factor

γ : Disturbance attenuation of H_∞

$\mathbf{P}(n)$: *a priori* error covariance matrix

$\mathbf{K}(n)$: Kalman gain

$\mathbf{h}(n)$: fading channel vector

$\hat{\mathbf{h}}(n)$: estimated fading channel

$\Phi(n)$: auto parameters matrix

$\mathbf{d}(n)$: observation vector

Appendix C

The GUI interface for OFDM system

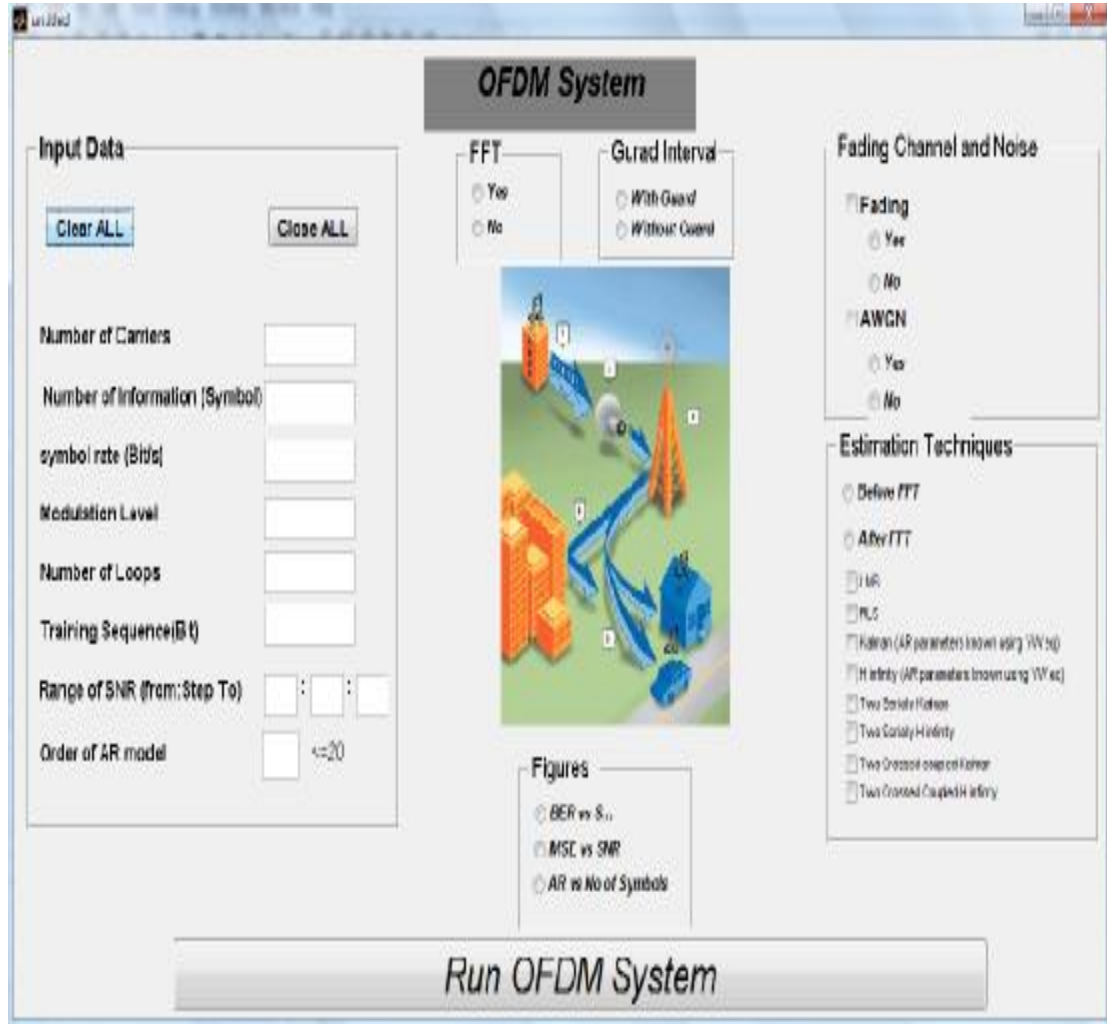

References

- [Abb05] Abbas Jamalipour , Tadahiro Wada, Takaya Yamazato – A Tutorial on Multiple Access Technologies for Beyond 3G Mobile Networks, *IEEE Communications Mag*, February 2005.
- [Bad05] K. E. Baddour, N. C. Beaulieu. – Autoregressive modeling for fading channel simulation. *IEEE Trans. on Wireless Communications*, vol. 4, pp.1650–1662., July 2005.
- [Bel63] P. A. Bello. –Characterization of randomly time-variant linear channels. *IEEE Trans. on Communications*, vol. 13, pp. 360–393, December 1963.
- [Bin90] J. Bingham, – Multicarrier modulation for data transmission: an idea whose time has come,” *IEEE Communication Magazine*, vol. 28,pp. 5–14, May 1990.
- [Bul98] Selaka Blumulla, Saleem Kassam and Santosh Venkatesh – An Adaptive Diversity Receiver for OFDM in Fading Channels, *IEEE Electronics Letters*, department of Electrical Engineering, University of Pennsylvania 1998.
- [Cai04] J. Cai, X. Shen, J. W. Mark. – Robust channel estimation for OFDM wireless communication systems - an H^∞ approach. *IEEE Trans. on Wireless Communications*, vol. 3, pp. 2060–2071, November 2004.
- [Cim85] L. J. Cimini, – Analysis and simulation of a digital mobile channel using orthogonal frequency division multiplexing, *IEEE Trans. Commun.*, vol. COM-33, pp. 665-675, July 1985.
- [Col02] Coleri. S, Ergen M., Puri, A, Bahai, A – Channel estimation techniques based on pilot arrangement in OFDM systems, *IEEE Transaction on Broadcasting* Vol.48, pages 223-229 Sept.2002.
- [Den93] P. Dent, G. Bottomley, T. Croft. – Jakes fading model revisited. *IEE Electronics Letters*, vol. 29, pp. 1162–1163, June 1993.

- [Der94] M. Deriche, – AR parameter estimation from noisy data using the EM algorithm, in *Proc. of the IEEE-ICASSP*, Adelaide, pp. 69-72, April 1994.
- [Erd00] A. Erdogan, B. Hassibi, T. Kailath – .On linear H_∞ equalization of communication channels .IEEE Trans. on Signal Processing ,vol. 48, pp. 3227-.3231, November 2000.
- [Ekl02] C. Eklund, Roger B. Marks, Kenneth L.Stanwood, and Stanley Wang –IEEE 802.16 Broadband Wireless Access Working Group, *IEEE Communications Magazine*, June 2002, pp. 98-107.
- [EST95] ETSI, – Digital audio broadcasting (DAB); DAB to mobile, portable and fixed receivers, *European Telecommunications Standard*, ETS 300-401, February 1995.
- [EST97] ETSI, – Digital video broadcasting (DVB); Framing structure, channel coding, and modulation for digital terrestrial television, *European Telecommunications Standard*, ETS 300-744, March 1997.
- [ETS00] ETSI, – Broadband radio access networks (BRAN); HIPERLAN type 2; Physical (PHY) layer, *European Telecommunications Standard*, TS 101-475, April 2000.
- [Gia98] G. B. Giannakis, C. Tepedelenlioglu. – Basis expansion models and diversity techniques for blind identification and equalization of time-varying channels. *Proceedings of the IEEE*, vol. 86, pp. 1969–1986, October 1998.
- [Har01] Harada H, Prasad, R -An OFDM-based wireless ATM transmission system assisted by a cyclically extended PN sequence for future broad-band mobile multimedia communications, *IEEE Transactions on Vehicular Technology*, Volume 50, Page(s):1366 – 1374, Nov. 2001.
- [Har02] Harada H, Prasad, R – Simulation and Software radio for mobile communications, Artech House 2002.
- [Has99] B. Hassibi, A. H. Sayed, and T. Kailath Indefinite quadratic estimation and control: a unified approach to an H_2 and H_∞ theories. Philadelphia, PA: SIAM, 1999.

[IEEE99] IEEE, – Supplement to standard for telecommunications and information exchange between systems – LAN/MAN specific requirements – Part 11: Wireless LAN medium access control (MAC) and physical layer (PHY) specifications: High speed physical layer in the 5 GHz band,” IEEE 802.11a, July 1999.

[Jak74] W. C. Jakes – *Microwave Mobile Communications*, Wiley, New York, 1974.

[Jam05] Ali Jamoos, David Labarre, Eric Grivel and Mohamed Najim, – Two Cross Coupled Kalman Filters for Joint Estimation of MC-DS-CDMA Fading Channels and Their Corresponding Autoregressive Parameters, in proceedings of the European Signal Processing Conference, EUSIPCO2005, Antalya, Turkey, September 4-8, 2005.

[Jam07a] Ali Jamoos, Ph.d thesis - Contributions on Receiver Design and Channel Estimation for Multi-Carrier DS-CDMA Mobile Systems, Equipe Signal et Image, Dpt LAPS IMS UMR CNRS 5218, Universit´e Bordeaux 1-June 2007.

[Jam07b] A. Jamoos, J. Grolleau, E. Grivel, H. Abdel Nour, M. Najim. – Kalman vs H_{∞} algorithms for MC-DS-CDMA channel estimation with or without a priori AR modeling. *IEEE Multi-Carrier Spread-Spectrum (MC-SS)*, Herrsching, Germany. Lecture Notes in Electrical Engineering, Springer Verlag, 2007.

[Jam07c] Ali Jamoos, Ahmad Abdo, and Hanna Abdel Nour, "Estimation of OFDM Time-Varying Fading Channels Based on Two-Cross-Coupled Kalman Filters," *The International Joint Conferences on Computer, Information, and Systems Sciences, and Engineering (CISSE 07)*, University of Bridgeport, USA, December 3 - 12, 2007.

[Jam08] Ali Jamoos, Ahmad Abdo, Hanna Abdel Nour and Eric Grivel- Two-Cross-Coupled H_{∞} Filters for fading channel Estimation in OFDM SYSTEMS, submitted to EUSIPC, 2008.

[Jan97] Jan-Jaap van de Beek, Magnus Sandell,- ML Estimation of Time and Frequency Offset in OFDM Systems, IEEE TRANSACTIONS ON SIGNAL PROCESSING, VOL. 45, NO. 7, JULY 1997

- [Kal03] D. N. Kalofonos, M. Stojanovic, J. G. Proakis. – Performance of adaptive MC-CDMA detectors in rapidly fading Rayleigh channels. *IEEE Trans. On Wireless Communications*, vol. 2, pp. 229–239, March 2003.
- [Kam93] Kam, P.Y.; Teong, L.C.; See, C.C.- Frequency offset estimation via planar extended Kalman filter, *IEEE Electronics Letters*, Volume 29, Page(s):1473 - 1474, 5 Aug 1993.
- [Kay88] S. M. Kay. – *Modern Spectral Estimation*, Prentice Hall, Englewood Cliffs, NJ, 1988.
- [Kom02] C. Komninakis, C. Fragouli, A. H. Sayed and R. D. Wesel, – Multi-input multi-output fading channel tracking and equalization using Kalman estimation, *IEEE Trans. On Signal Processing*, vol. 50, no.5, pp. 1065-1076, May 2002.
- [Lab06] D. Labarre, E. Grivel, Y. Berthoumieu, E. Todini and M. Najim, “Consistent estimation of autoregressive parameters from noisy observations based on two interacting Kalman filters,” *Signal Process.*, vol. 86, pp. 2863-2876, October 2006.
- [Lab07] D. Labarre, E. Grivel, M. Najim, – Dual H_∞ algorithms for signal processing, application to speech enhancement, *IEEE Trans. on Signal Processing*, vol. 55, no. 11, pp. 5195-5208, Nov. 2007.
- [Las03] S. Lasaulce, P. Loubaton, E. Moulines. – A semi-blind channel estimation technique based on second-order blind method for CDMA systems. *IEEE Trans. on Signal Processing*, vol. 51, pp. 1894–1904, July 2003.
- [Lin02] L. Lindbom, A. Ahlen, M. Sternad, M. Falkenstrom. – Tracking of time-varying mobile radio channels. II: a case study. *IEEE Trans. on Communications*, vol. 50, pp. 156-167, January 2002.
- [Liu01] H. Liu, H. Yin. – Receiver design in multicarrier direct-sequence CDMA communications. *IEEE Trans. on Communications*, vol. 49, pp. 1479–1487, August 2001.

[Liu05] Hui Liu, Guoqing Li, – OFDM-Based Broadband Wireless Networks Design and Optimization, John Wiley & Sons, Inc, 2005.

[Meh07] Mehemt K. Ozdemir – Channel estimation for wireless OFDM systems IEEE communication survey, Volume 9, NO. 2, 2nd Quarter 2007.

[Mor07] M. Morelli, C.Jay Kuo and Man-On Pun – Synchronization Techniques for Orthogonal Frequency Division Multiple Access (OFDMA):Tutorial Review, *Proceeding of the IEEE* Vol95 No 7 July 2007.

[Pap02] A. Papoulis, S. U. Pillai. – *Probability, Random Variables and Stochastic Processes*, McGraw-Hill, New York, 2002.

[Pra98] Ramjee Prasad, Tero Ojanpera –An Overview of CDMA Evolution Toward WideBand CDMA, *IEEE Communications*, Vol. 1 No. 1, Fourth Quarter 1998.

[Pup05] Rahul N. Pupala – Introduction to Wireless Electromagnetic Channels & Large Scale Fading, EE-546, Spring 2005.

[Rap01] T. S. Rappaport. – *Wireless Communications: Principles and Practice*, Prentice Hall, 2001.

[Sal67] B.R. Salzberg, – Performance of an efficient parallel data transmission system, *IEEE Trans.Commun.*, vol. COM-15, pp. 805-813, Dec. 1967.

[Sel99] Audrey Selian, - 3G Mobile Licensing Policy: GSM Case Study, International Telecommunication Union (ITU) found at www.itu.int/osg/spu/ni/3G/casestudies/GSM-FINAL.pdf.

[She97] X. Shen and L. Deng, – Game theory approach to discrete H_{∞} filter design, *IEEE Trans. Signal Process.*, pp. 1092–1095, April 1997.

[She99] X. Shen, L. Deng. – A Dynamic system approach to speech enhancement using the H_{∞} filtering algorithm. *IEEE Trans. on Speech and Audio Processing*, vol.7, pp. 391–399, July 1999.

[Stü02] Gordon L. Stüber – *Principles of Mobile Communication* Georgia Institute of Technology Atlanta, Georgia USA, Kluwer Academic Publishers, 2002.

[Ton04] L. Tong, B. M. Sadler, M. Dong. – Pilot-assisted wireless communications. *IEEE Signal Processing Mag*, vol. 21, pp. 12–25, November 2004.

[Tsa96] M. Tsatsanis, G. B. Giannakis and G. Zhou, – Estimation and equalization of fading channels with random coefficients, *IEEE Signal Processing Mag.*, vol. 53, pp. 211-229, Sept. 1996.

[Wal06] Walid Hassasneh, Ali Jamoos, Eric Grivel and Hanna Abdel Nour – Estimation of MC-DS-CDMA Fading Channels Based on Kalman Filtering with High Order Autoregressive Models," , *Mobile Computing and Wireless Communications international conference (MCWC2006)*, Amman-Jordan, September 2006.

[Wan00] Z. Wang, G. B. Giannakis. – Wireless multicarrier communications: where Fourier meets Shannon. *IEEE Signal Processing Mag.*, vol. 17, pp. 29–48, May 2000.

[Wei71] S.B. Weinstein and P.M. Ebert, “Data transmission by frequency-division multiplexing using the discrete Fourier transform”, *IEEE Trans. Commun. Technol.*, vol. COM-19, pp. 628-634, Oct. 1971.

[Xia03] P. Xia, S. Zhou, and G. B. Giannakis, -Bandwidth- and Power-Efficient Multicarrier Multiple Access,” *IEEE Trans. Commun.*, vol. 51, no. 11, pp. 1828–37, Nov. 2003.

[Yan03] L. Yang and L. Hanzo, – Multicarrier DS-SS: A Multiple Access Scheme for Ubiquitous Broadband Wireless Communications, *IEEE Com. Mag.*, vol.41, no. 10, , pp. 116–24, Oct. 2003.

References

[Yee93] Yee, J.P.M.G. Linnartz and G. Fettweis, – Multi-Carrier CDMA in indoor wireless Radio Networks, *IEEE Personal Indoor and Mobile Radio Communications (PIMRC) Int. Conference*, Yokohama, Japan, pp. 109-113, Sept. 1993.

[Yeh02] Che-Shen Yeh and Yinyi Lin-Channel Estimation Using Pilot Tones in OFDM Systems, *IEEE Transaction on Broadcasting* , Vol. 48, SEPTEMBER 2002.

References

[Yoo06] H. Yoon; L. Kuang; J. Lu - Carrier Frequency Offset Estimation Using Extended Kalman Filter in Uplink OFDMA Systems, IEEE International Conference in Communications on Volume 6, June 2006.