

# INTERRUPTION OF WEAKLY COOLED ARCS IN AIR AND AIRPLUS

N. RANJAN\*, J. CARSTENSEN, S. SCHEEL

*ABB Switzerland Ltd, Corporate Research, Segelhofstrasse 1, 5405 Baden-Dättwil, Switzerland*

\* [nitesh.ranjan@ch.abb.com](mailto:nitesh.ranjan@ch.abb.com)

**Abstract.** Switching of low current arcs in free burning or weakly cooled conditions is mainly determined by the thermal properties of the gas. Products with such switching conditions are widely found in secondary distribution medium voltage (MV) gas insulated switchgears (GIS). In this study, we compare the current interruption capability of synthetic air and AirPlus<sup>TM</sup>, i.e. a mixture of synthetic air with C<sub>5</sub>F<sub>10</sub>O fluoroketone (C5-FK). We focus on thermal interruption performance of the gases. AirPlus mixture corresponds to -25°C condensation temperature of C5-FK. An arc is drawn between the contacts and cooled by blowing cold gas from a tank. Blowing pressure required for current interruption is compared. Within the measurement accuracy, the current interruption performance of both gases is similar. Chemical analysis of the AirPlus mixture after 69 shots was performed using Gas Chromatography Mass Spectroscopy (GCMS) and it shows very little decrease in the concentration of C5-FK.

**Keywords:** weakly cooled arcs, load break switches, C5-FK, thermal interruption.

## 1. Introduction

Load break switches (LBS) are often used in medium voltage (MV) secondary distribution for interrupting low currents typically in the range of few hundreds of Ampere. The arc in the LBS is either free burning or very weakly blown. In these situations, current interruption is mainly determined by the intrinsic physical properties of the arcing medium. SF<sub>6</sub> is currently used in LBSs owing to its extremely good switching and dielectric properties.

SF<sub>6</sub> has a high global warming potential (GWP) and this might lead to regulations in future to minimize its usage in specific applications, e.g. European Union (EU) has targeted to replace SF<sub>6</sub> specifically from MV secondary distribution GIS [1]. Recently, the search for an alternative gas with low GWP value has intensified for high and medium voltage applications. It is challenging to find a gas which has as good switching, dielectric, and thermal properties as that of SF<sub>6</sub>. In last years, different families of molecule like perfluoroketones (PFK) [2], perfluoronitriles (PFN) [3] have emerged as a promising candidate for an alternative gas. These gases have a relatively high boiling point and so they must be used in mixture with other gases (like air or CO<sub>2</sub>) for low temperature applications (-5°C or below). Different groups have reported on the switching [4, 5] and insulation [6, 7] properties of these gases for HV [3, 8] and MV [9–11] applications. In this article, we compare the current interruption capabilities of AirPlus, i.e. a mixture of C<sub>5</sub>F<sub>10</sub>O fluoroketone (C5-FK) with air. Current and voltage waveforms were based on the IEC norm for active load test duty of 24 kV/630 A rating of LBS [12]. We specifically evaluate the thermal interruption capability of AirPlus mixture and compare it with air. Thermal interruption phase is dominated

by current ( $\frac{di}{dt}$ ) and voltage ( $\frac{du}{dt}$ ) stresses in a small time window (few 10 μs) around current zero (CZ). We did not explore the performance of the gas in the presence of the transient recovery voltage (TRV) peak or the recovery voltage which appears later. For our experiments, the arc is weakly cooled, i.e. the flow is sub-sonic. After the experiments were completed, gas samples were taken and analysed for the formation of decomposition product and decrease in the C5-FK concentration.

## 2. Experimental method

The test object (TO) has been designed in a way that several parameters (blowing pressure, travel, working gas) can be varied independently. It is a metal enclosed housing of 250 litre volume which can be filled to different pressures. The housing encloses a model LBS and a drive to move the contacts. The model LBS consists of a plug-tulip contact made of tungsten-copper and a nozzle made from transparent Poly-methyl-methacrylate (PMMA). A simple pneumatic cylinder is used as a mechanical drive to move the contacts. The stroke was adjusted to 85 mm and the average speed was in the range of 3–5 m/s. The metal housing also has a quartz window to gain direct optical access to the arcing zone. A high speed camera with a maximum frame rate of 14000 fps is used to capture videos of the arcing zone during current interruption.

### 2.1. Test circuit

During the experiment, an arc is drawn between the contacts by moving them apart. Such an arcing event is referred to as "shot" in the rest of this article. During a typical shot, the plasma created during the high current phase starts to cool down as CZ is approached. If

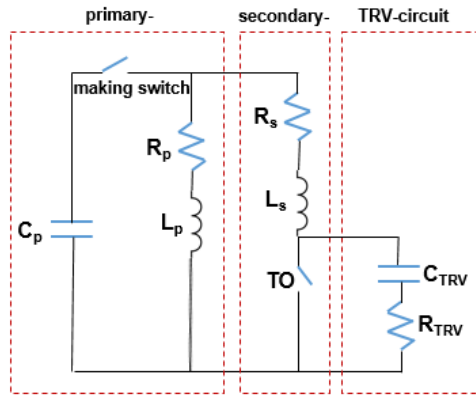

Figure 1. Electrical circuit.

the plasma is not sufficiently cooled and stays conductive, the current continues after CZ. This is referred to as "thermal failure". Both the current and voltage stresses at CZ are decisive for successful thermal interruption. The circuit was built accordingly to measure the thermal interruption performance of the gas.

The electrical circuit consists of three parallel branches as shown in Figure 1. The primary circuit is optimized for low damping by using coils with low ohmic losses (large conductor cross section) and tuned to a frequency of 50 Hz. The TO is located in the secondary circuit, where the current is limited by a high inductance  $L_s$ . Since  $L_s > L_p$ , only a small fraction of the current is bypassed through the secondary circuit so that the damping rate is mostly determined by the primary circuit, and there is only a minor change in the power frequency due to the influence of the secondary circuit. The rate of rise of recovery voltage (RRRV) is adjusted by a capacitor and a resistor parallel to the TO. The nominal values of the circuit elements are compiled in Table 1. The circuit impedance  $Z_{\text{circuit}} = \left. \frac{du/dt}{di/dt} \right|_{\text{CZ}}$  seen by the test object is mostly determined by the resistor  $R_{\text{TRV}}$ , and  $Z_{\text{circuit}}$  was adjusted to  $250 \Omega$  by choosing an appropriate  $R_{\text{TRV}}$ . During the experiment, if the current through the TO changes, the RRRV is changed as well, since the  $Z$  is fixed ( $\frac{du}{dt} = Z \frac{di}{dt}$ ). The value of  $Z$  for common ratings of LBS is shown in Table 2. The circuit components were adjusted so that at a charging voltage of  $\approx 3 \text{ kV}$  of  $C_p$  the desired current ( $I_{\text{rms}} \approx 630 \text{ A}$ ) is flowing through the model LBS. Lower charging voltages would have led to arc circuit interaction around CZ, while the highest achievable charging voltage was limited by the voltage rating of the capacitors  $C_p$  to 4 kV. The TRV peak was typically in the range of 3–4 kV depending on the charging voltage.

## 2.2. Gas handling system

The TO was filled to 1.3 bar, a pressure typical for LBS. In some LBS, the puffer mechanism is used to create a gas flow which cools the arc [11]. We

Circuit element	Values
$C_p$	7 mF, charged to 4 kV
$L_p, R_p$	1.66 mH, 15.5 m $\Omega$
$L_s, R_s$	7.4 mH, 0.1–1 $\Omega$
$C_{\text{TRV}}, R_{\text{TRV}}$	2 $\mu\text{F}$ , 310 $\Omega$
$f$	$\approx 50 \text{ Hz}$
$Z_{\text{circuit}}$	$\approx 250 \Omega$

Table 1. Circuit elements corresponding to the schematic shown in Figure 1.

Rated voltage	RRRV <sub>CZ</sub>	Z
kV	V/ $\mu\text{s}$	$\Omega$
12	51.5	184
24	70	250
36	86	308

Table 2. RRRV and effective impedance at current zero according to the IEC mainly active load type test duty for a current of 630 A and different rated voltages [12].

wanted to control the pressure required to cool the arc independently from the stroke and so a closed gas flow system was built around the TO. The schematic of the gas handling system is shown in Figure 2. At the beginning of each experiment, the high pressure tank ( $V_{\text{HP}}$ ) is charged with gas to high pressures by the compressor. The pressure in  $V_{\text{HP}}$  is highest amongst all volume elements as it controls the pressures in the tank and TO. Two precision pressure regulators are directly connected to  $V_{\text{HP}}$  and are used to maintain a constant pressure in the tank ( $p_{\text{tank}}$ ) and TO ( $p_{\text{TO}}$ ). In this way, the pressure in the TO is kept constant at 1.3 bar and the pressure in the tank is independently and precisely controlled. During any experiment the valve was opened for a certain amount of time and the gas flew from the tank to the TO to cool the arc. This system was used for both the series of experiments related to air and AirPlus.

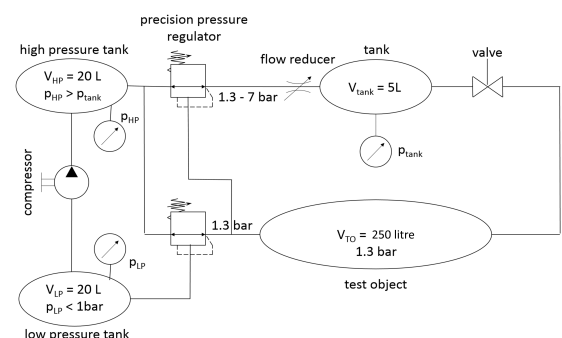

Figure 2. Sketch of the gas handling system.

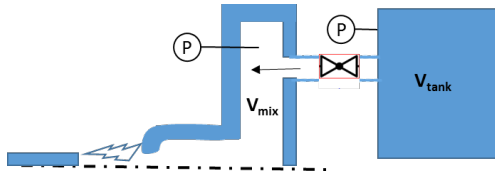

Figure 3. Sketch of gas flow path from tank to arc during any shot. © denotes pressure sensor mounted to the tank and mixing volume.

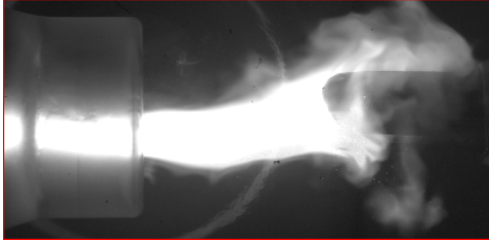

Figure 4. Image from high speed camera.

### 2.3. Experimental procedure

During any shot, the arc was drawn between the contacts and cooled by blowing the gas from the tank. The gas flows from the tank to the "mixing volume" inside the TO and then through the tulip into the arcing zone. The schematic of the blowing mechanism is shown in Figure 3. The mixing volume ( $V_{mix} \approx 0.5$  litre) was equipped with a differential pressure sensor to measure the pressure  $p_{mix}$ . Since the pressure in the TO is fixed to 1.3 bar, measurement of the pressure inside the mixing volume directly gives the pressure drop across the tulip  $\Delta p$ . During any shot, the blowing was started first and a flow was established before an arc was drawn between the contacts. The current was injected just before contact separation so that the arcing time is in the range of  $t_{arc} = 8-10$  ms. Interruption was considered successful, when it took place at the first CZ after the contact separation, otherwise it was considered as a failure. The high speed camera was used to make video during the entire arcing time. Figure 4 shows an image of the arc drawn between the contacts. Figure 5 shows current through the TO and the arc voltage for a typical shot (resulting in interruption).

We used the standard Up&Down statistical method [13] to determine the current ( $I_{50}$ ) at which holds and fails occur with 50% probability for a fixed set of parameters (blowing pressure,  $Z$ , travel, speed).

We used a mixture of  $\approx 8\%$  C5-FK and air. This mixture remains fully gaseous down to temperature of  $-25^\circ\text{C}$ . The total filling pressure was 1.3 bar. For the case of air, synthetic air was filled up to 1.3 bar inside the TO.

## 3. Results and dicussion

### 3.1. Interruption performance

Figure 6 shows the result from the two experimental test series.  $I_{50}$  is plotted against the blowing over-

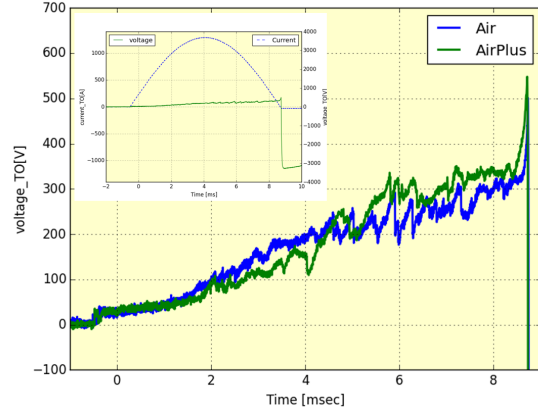

Figure 5. Arc voltage of AirPlus and air. Inset shows the current and the TRV-peak.

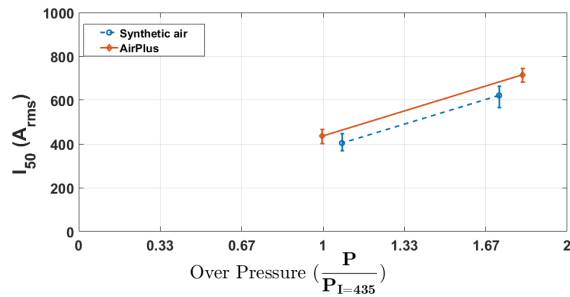

Figure 6.  $I_{50}$  against the normalized pressure drop across the tulip.

pressure. The X-axis shows the pressure required to interrupt a current normalized by the pressure required to interrupt 435 A of current for AirPlus. From the plot, we can conclude that within the measurement accuracy, the interruption performance of both gases are similar. Addition of C5-FK has no significant influence and the thermal interruption performance of the mixture is dominated by air which contribute to about 92% of the mixture. Figure 5 shows the arc voltage from a measurement of air and AirPlus for the same current and blowing over-pressure. From the plot one sees that there is no significant difference in the arc voltage of the two gases. The inset in the figure shows the current and the full TRV peak.

The energy injected into the gas volume can be estimated by the following procedure. Taking an average arc voltage of 200 V from Figure 5 and 630 A current and 10ms of arcing time leads to an approximate value of 87 kJ of energy for all the 69 shots. But the actual energy input should be higher than the approximate value because we have performed up-down statistics on current and many of the shots have higher than 630 A of current flowing. For example Figure 5 shows about 920 A of current. Besides this, about 50% of the shots resulted in fails and for these shots, the arcing time varied between 20–50 ms. Hence the total energy input can be estimated to be 3–4 times higher

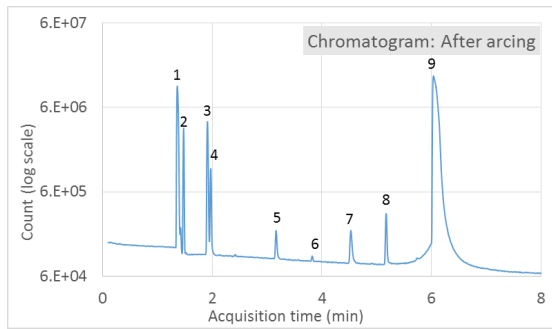

Figure 7. Chromatogram of gas sample taken after the arcing experiment.

Nr.	Chemical name	Formula
1	Nitrogen/Oxygen	$N_2, O_2$
2	Tetrafluoromethane	$CF_4$
3	Carbondioxide	$CO_2$
4	Hexafluoroethane	$C_2F_6$
5	Octafluoropropane	$C_3F_8$
6	Hexafluoropropene	$C_3F_6$
7	Decafluorobutane	$C_4F_{10}$
8	2H-Heptafluoropropane	$C_3HF_7$
9	C5-FK	$C_5F_{10}O$

Table 3. Molecules found after the test.

than the approximate value. Taking an integral of  $I \times V$  for all shots we get 341 kJ which is close to the approximate calculation.

### 3.2. Decomposition products

Experiments were performed without any adsorbent inside the TO to get the full composition of the by-products. For experiments with AirPlus, gas samples were taken before and after the test and given for analysis using GCMS [14]. The chromatogram of the sample after testing is shown in Figure 7. The peak in retention time corresponds to different species present in the gas sample. The molecules corresponding to these peaks are shown in Table 3. These created molecules are also found in other investigations related to switching in C5-FK mixture [5]. All of these compounds have LC50 value (4 hour exposure to rats) greater than 2500 ppmv and hence they are not toxic according to GHS regulation [15]. Fourier transform infrared spectroscopic measurements were not performed and therefore the presence of CO or  $CF_2O$  cannot be excluded. Comparison of the GCMS results from gas samples taken before and after the experiments show very little drop in the concentration of C5-FK. Pressure was measured in all the volume elements during the experiment and negligible pressure rise below 20 mbar was observed.

## 4. Conclusions

In this report we compared the low current thermal interruption performance of AirPlus with air in

weakly blown conditions. The dielectric performance of the mixture is not compared. The results show that AirPlus has similar thermal interruption performance as compared to air. Chemical analysis of the gas samples with GCMS shows no toxic by-products and very little decrease in the composition of C5-FK. There was negligible pressure rise after the experiment.

## References

- [1] Regulation (EU) no 517/2014 of the European parliament and the of council of 16 april 2014 on fluorinated greenhouse gases and repealing regulation (EC) no 842/2006.
- [2] J.D. Mantilla et al. Investigation of the insulation performance of a new gas mixture with extremely low GWP. In *Electrical Insulation Conference*, Philadelphia, USA, 2014. doi:10.1109/EIC.2014.6869432.
- [3] Y. Kieffel et al. Alternative gas to  $SF_6$  for use in high-voltage switchgears:  $g^3$ . In *CIREN*, Lyon, France, 2015. Paper 0230.
- [4] P.C. Stoller et al. Mixtures of  $CO_2$  and  $C_5F_{10}O$  perfluoroketone for high voltage applications. *submitted to IEEE Trans. Dielectrics and Electrical Insulation*, 2017.
- [5] B. Radisavljevic et al. Switching performance of alternative gaseous mixtures in high-voltage circuit breakers. In *submitted to 20th Int. Symp. on High Voltage Engineering*, Buenos Aires, Argentina, 2017.
- [6] C. Preve et al. Validation method and comparison of  $SF_6$  alternative gases. In *Cigre Session*, Paris, France, 2016.
- [7] P. Simka et al. Dielectric strength of C5 perfluoroketone. In *19th Int. Symp. on High-Voltage Engineering*, Pilsen, Czech Republic, 2015.
- [8] D. Tehlar et al. Ketone based alternative insulation medium in a 170 kV pilot installation. In *Cigre Colloquium*, Nagoya, Japan, 2015.
- [9] M. Hyrenbach et al. Alternative gas insulation in medium-voltage switchgear. In *CIREN*, Lyon, France, 2015. Paper 0587.
- [10] M. Saxegaard et al. Dielectric properties of gases suitable for secondary medium voltage switchgear. In *CIREN*, Lyon, France, 2015. Paper 0926.
- [11] M. Saxegaard et al. Low current interruption in  $SF_6$ -alternatives. In *CIREN*, Glasgow, UK, 2017. Paper 0614.
- [12] High-voltage switchgear and controlgear part 103: Switches for rated voltages above 1 kV up to and including 52 kV. 62271-103. IEC International Standard, 2011.
- [13] D.J. Dixon and A.M. Mood. A method for obtaining and analyzing sensitivity data. *J. of the Am. Stat. Association*, 43(241):109–126, 1948. doi:10.2307/2280071.
- [14] P. Simka et al. Decomposition of alternative gaseous insulation under partial discharge. In *submitted to 20th Int. Symp. on High Voltage Engineering*, Buenos Aires, Argentina, 2017.
- [15] Globally harmonized system of classification and labelling of chemicals (Sixth revised ed.), New York and Geneva: United Nations, 2015.