

Artículo Científico

Recibido: 17 de octubre 2010;

Aceptado: 30 de febrero 2011.

Energy efficiency as a SON mechanism for HSPA+ networks

Eficiencia Energética como un mecanismo SON para redes HSPA+

Marcelo Jaimes¹, Ana García Armada²

¹Universidad Católica Boliviana, Dept. de Ciencias Exactas e Ingeniería, Cochabamba, Bolivia; ²Universidad Carlos III de Madrid Dept. Signal Theory and Communications, Madrid, Spain

marcelo.jaimes.mail@gmail.com

Abstract: The operation of mobile networks incurs significant amounts of energy consumption. From a network operation point of view reduction of energy consumption is not only a matter of environmental responsibility but also reduces the operational costs and improves network performance minimizing some daily problems. In our study we apply an energy saving mechanism by means of Self-Organizing Networks (SON) functionality. We show that it is possible to reduce energy consumption and also control cell breathing bringing more Quality of Service (QoS) to the network.

Key words: UMTS, HSPA, Energy Efficiency, Green Mobile Networks, Self-Organizing Networks, SON.

Resumen: La operación de las redes móviles incurre en importantes cantidades de consumo de energía. Desde un punto de funcionamiento de la red de la reducción de vista del consumo de energía no es sólo una cuestión de responsabilidad ambiental, sino que también reduce los costes operativos y mejora el rendimiento de la red minimizando algunos problemas cotidianos. En nuestro estudio, aplicamos un mecanismo de ahorro de energía por medio de la auto-organización de redes (SON) funcionalidad. Se demuestra que es posible reducir el consumo de energía y también controlar la respiración celular generando mayor calidad de servicio (QoS) en la red.

Palabras clave: UMTS, HSPA, Eficiencia Energética, Redes verdes móviles, redes de auto-organización, SON.

1 Introduction

During the last years the problem of energy consumption has been gathering a lot of importance for the Information and Communication Technologies (ICT) industry from both an environmental and economic point of view.

ICT infrastructures are responsible for about 2% to 10% of world's total energy consumption [1]. From that amount 10% is used by mobile communications systems. ICT indicators for 2008 showed that sixty billions of KWh was consumed, generating forty millions of CO₂ metric tons, which is approximately the emission of greenhouse gases of eight million cars per year.

On the other hand, the deployment and operation of mobile networks are not simple tasks because they imply many activities such as: planning, dimensioning, deployment, tests, pre-optimization before commercial operation, daily optimization, performance monitoring, failures mitigation, error corrections and maintenance in general; activities that frequently are susceptible of errors and cause performance degradation.

In this sense, the Next Generation Mobile Networks (NGMN) and other organizations have promoted the inclusion of automated processes on the different levels of a mobile system, bearing the concept of Self-Organizing Networks (SON), which nowadays is a feature that is included in the latest releases of Long Term Evolution (LTE) and High Speed Packet Access (HSPA).

There are some studies related to switching cells on/off that show that when we know the traffic profile it is possible to save energy [1], [13], [17]. Other studies like [2], [10], [11], [12], propose a deployment of certain topologies or BS coordination to reduce power consumption. Studies like [3] and [9] present SON mechanisms that use auto-planning or auto-optimization to make it possible to reach energy efficiency. The difference between the previous mentioned studies and our work is that we intend to show that the application of an energy saving mechanism is not only beneficial for reducing power consumption but also for minimizing network performance problems by employing an auto-optimization procedure to solve call drop problems or lack of coverage on UMTS/HSPA networks.

Our article is organized as follows: in section II we describe the HSPA+ and SON framework; in section III we define the problem and the proposed model; in section IV we describe the power control mechanism and our simulation results; finally in section V we present our conclusions.

2 HSPA+ and SON Framework

The 3rd Generation Partnership Project (3GPP) included the High-Speed Packet Access (HSPA) in release 5 for downlink and release 6 for uplink. Since then, with the releases 7, 8, 9 and 10, there have been many improvements for user performance and network efficiency [14].

Actually the evolution of HSPA continues with release 11 and subsequent releases where the main topics are multi-carrier and multi-band improvements, multi-antenna solutions on uplink, coordinated multipoint transmissions and self-organizing networks.

2.1 SON Framework

Market growth, related to user proliferation, new handsets, development of new applications and services that demand higher bandwidth under severe QoS policies, entails the deployment of more and more complex and heterogeneous networks. Growth in the number of deployed micro, pico and femto cells (optimizing coverage and capacity with respect to macro cells) as well as the co-existence of multi-technology networks (2G/3G/4G/WiFi/etc.) is expected. These developments and a strong growth in data volumes in a dynamic scenario [4] demand an increase in service provisioning and engineering staff of companies. From a network point of view the different SON functionalities are described in table 1, see [5], [6], [7].

Table 1. Table 1: SON functionalities

Auto-Organization				
Auto Configuration	Auto Planning	Auto Optimization	Auto Management	Auto Healing
Process where newly deployed nodes are configured with automatic procedures to reach a basic configuration necessary for the operation of the system.	Processes where radio-planning parameters are assigned to a newly deployed node. e.g.: neighbor relations, transmission power, handover parameters, etc..	UE and Node B measurements plus KPIs are used to auto adjust the network. Change of parameters, thresholds, neighbors, etc. To minimize the operational effort, to increment the performance and QoS.	O&M Tasks automation. The network is responsible for lower level management while human operators overview and support at a higher management level.	This functional entity detects and solves problems by itself avoiding an end-user impact. Alarms monitoring and correlated KPS processing.

In [17] and [18] auto-configuration and auto-optimization functionalities have been defined (see figure 1). For instance, there is a ramification that focuses on the applicability of SON at a Node B level to contribute energy saving using techniques as load balance or automatically switching cells on/off.

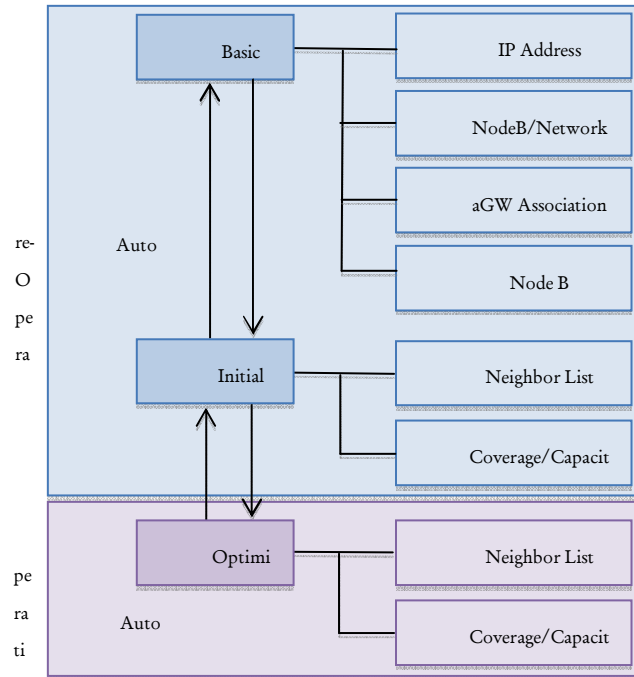

Figure 1: Auto-configuration and Auto-Optimization functions

2.2 Energy Efficiency Approach

A mobile operator can use different approaches for energy efficiency [15]:

- An appropriate design of the handsets from an energy consumption point of view. This point is related to the handset hardware design independent of the radio technology.
- Adopt planning and optimization techniques particularly focused on minimizing excessive network signaling.
- Adopt planning and optimization techniques particularly focused on decreasing the power radiated by antenna's.

2.2.1 Static Energy Efficiency

One of the simplest approaches to minimize energy consumption is switching on/off BS or certain modules of BS's, which are scheduled according

to traffic profiles or historic information. We cannot always apply this approach mainly due two reasons:

- A cell which over a certain observation time has not reported significant traffic cannot always be switched off, because it can be the only server in that area. If switched off it would cause coverage holes in the service area.
- Decisions cannot be merely based on statistics of traffic profiles, since these are dynamic and vary over time.

2.2.2 Dynamic Energy Efficiency

This is an extension of the static approach. The static approach doesn't allow the system to react to certain abnormal traffic behaviors, so reactivating the cell before the scheduled time is proposed.

The reactivation is possible by performing an accurate and detailed monitoring of the actualizations that are reported periodically to the management system; nevertheless this reactivation entails a delay.

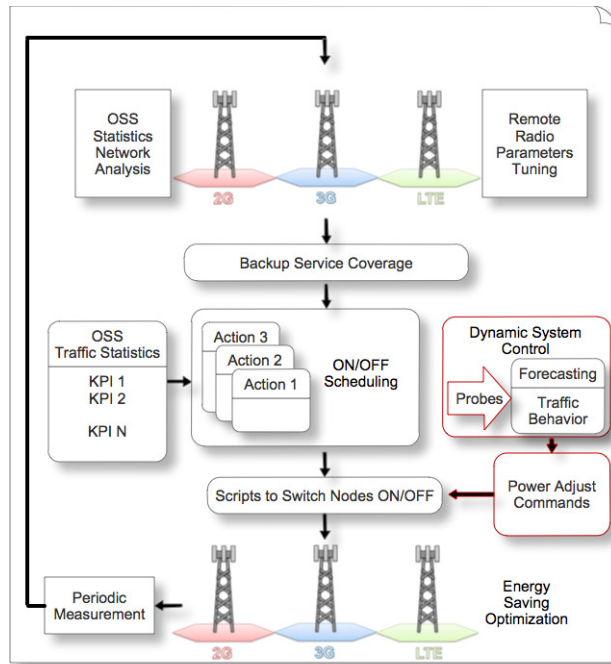

Figure 2: Energy Saving Operation

In figure 2, we can see the energy saving static approach but with the inclusion of a dynamic system control that permits the energy saving dynamic approach.

3 SON Energy Saving Simulation Scenario

The main objective of energy efficiency for green mobile networks is to reduce the excessive energy consumption over time intervals when there are few users of the network.

Planning, deployment and operation of mobile networks have traditionally been based on maximum load estimations; in other words, dimensioning was mostly based on peak hour traffic targets.

This kind of dimensioning for HSPA networks, which is based on WCDMA and hence are interference limited systems (as can be seen in figure 3), generates time periods in which the cell is filled with interference diminishing the effective coverage area. On the other hand, there are periods where there is little interference in the cell so its coverage increases invading neighboring cells with interference degrading the link quality and putting the QoS at risk.

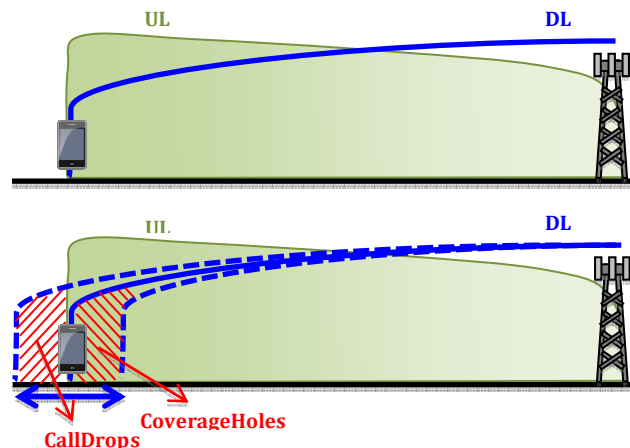

Figure 3: UL vs. DL coverage trade-off

To be able to analyze this behavior we define two study sets: A) We try to forecast the traffic profile per week served by a cell through real statistics of an HSPA network; B) We design the radio access link of a dense urban UMTS/HSPA cell.

3.1 Traffic Forecast

Our first step is to apply a forecasting technique to predict the traffic behavior of a cell. After processing the series and removing the tendency and seasonality information we look forward to obtain a remainder without statistic dependencies between the observations.

$$U_t = X_t - \bar{X}_t - (c_0 + c_1x^1 \dots c_nx^n) - S_t \tag{1}$$

$$S_t = a_0 + \sum_{k=1}^N [a_k \cos(w_k t) + b_k \sin(w_k t)] \tag{2}$$

X_t is the operator traffic measurement signal; \bar{X}_t is the signal mean; $c_0 + c_1x^1 \dots c_nx^n$ are the coefficients of the polynomial tendency; S_t represents seasonality through a Fourier series; U_t is the signal remainder.

Studying the remainder through a partial auto-correlation function (PACF) we observe that the best forecasting model that fits the prediction is an auto-regressive model, as Burg or Yule-Walker.

$$d(1) = \sum_{i=2}^n (x_i^2 + x_{i-1}^2) \tag{3}$$

$$\hat{\phi}_{ii} = \frac{2}{d(i)} \sum_{t=i+1}^n e_{i-1}^F(t) e_{i-1}^B(t-1) \tag{4}$$

$$d(i+1) = (1 - \hat{\phi}_{ii}^2) d(i) - (e_i^F(i+1))^2 - (e_i^B(n))^2 \tag{5}$$

$$\sigma_i^2 = \frac{1}{2(n-1)} [(1 - \hat{\phi}_{ii}^2) d(i)] \tag{6}$$

Applying the auto-regressive models we can observe in figure 4 that the prediction is quite accurate. The error made is acceptable.

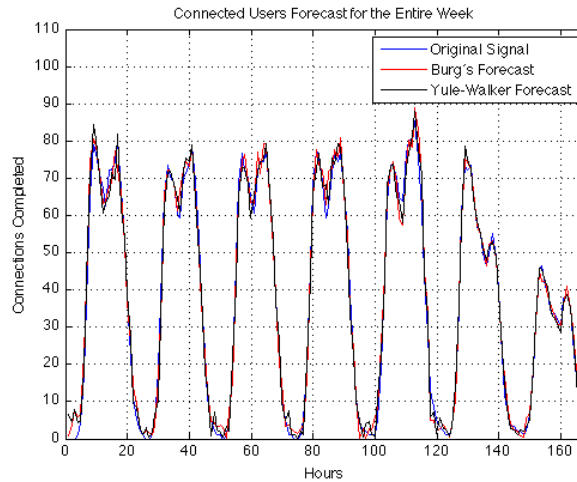

Figure 4: Forecasting applying auto-regressive models

3.2 Radio Access Planning

Our second step is to dimension a UMTS/HSPA access network and observe how we can apply a possible and beneficial energy saving mechanism given the traffic forecast.

The input parameters used for the design are described in table 2.

Table 2. Mobile System Parameters

Parameter	Value
Technology	UMTS/HSPA
Frequency [MHz]	2100
Environment type	Dense Urban
Service	Real Time
AMR Rate [Kbps]	12.2
Node B Tx Power [W]	15
UE Tx Power [W]	0.25
Node B Eb/No [dB]	5.7
UE Eb/No [dB]	3
Propagation model	COST 231

The Node B radio configuration is designed to reach the maximum allowable propagation loss, which is the least effective signal power between UE and Node B, guaranteeing link establishment under the given QoS targets.

The link budget is calculated in table 3 with the maximum allowed propagation loss on uplink and downlink. For UMTS/HSPA, as a WCDMA system, performance is limited by the amount of interference generated by the cell load, which has a direct impact on the cell range or coverage, unbalancing the uplink and downlink. This phenomenon is known as cell breathing (figure 3).

Table 3. Link Budget

Parameter	UPLINK	DOWNLINK
Transmitter	UE	Node B
Max. Transmission Power [W]	0,24	15,00
Max. Transmission Power [dBm]	23,80	41,76

Antenna Gain [dBi]	2,00	18,00
Cable Loss including MHA [dB]	2,00	4,00
EIRP [dBm]	23,80	55,76
Receiver	Node B	UE
Rx Antenna Gain [dBi]	18,00	1,00
Cable Loss [dB]	4,00	3,00
Thermal Noise Density [dBm/Hz]	-174,00	-174,00
Receiver Noise Figure [dB]	5,00	9,00
Receiver Noise Power [dBm]	-103,16	-99,16
Eb/No [dB]	5,70	3,00
Rate [kbps]	12,20	12,20
Receiver Sensitivity [dBm]	-122,44	-121,14
Margins (additional gains and loses)		
Interference Margin (Noise Rise) [dB]	2,22	3,98
Soft Handover Gain [dB]	2,00	0,00
Fast Fading Margin [dB]	5,00	5,00
Body Loss [dB]	2,00	2,00
Power Sparkles [dB]	0,00	2,50
Maximum Allowed Propagation Loss [dB]	153,02	161,42
Coverage Reliability		
Outdoor Probability Coverage at cell Edge	90,00	90,00
Outdoor Slow Fading Margin [dB]	7,00	7,00
Maximum Allowed Propagation Loss Outdoor Coverage [dB]	146,02	154,42
Indoor Probability Coverage at cell Edge	90,00	90,00
Indoor Building Penetration Loss [dB]	20,00	24,00
Car Penetration Loss [dB]	0,00	0,00
Indoor Slow Fading Margin [dB]	7,00	8,00
Maximum Allowed Propagation Loss Indoor Coverage [dB]	126,02	129,42

The interference consists of two main parts: I_{own} and I_{other} . There is also a interference contribution of other systems $I_{other_systems}$ and thermal noise N .

$$I_{TOTAL} = I_{own} + I_{other} + I_{other_systems} + N \quad (7)$$

Where I_{own} is the interference generated by the users of the same cell; I_{other} is triggered by users of other cell and the Node Bs that serve those users. These concepts allow us to define the i factor relation that is the relation between the interference generated by other cells and the own cell interference.

$$i = \frac{I_{other}}{I_{own}} \quad (8)$$

Uplink load η_{UL} on a cell is the sum of every particular user load.

$$\eta_{UL} = \sum_{j=1}^N \frac{1}{1 + \frac{(E_b/N_0)_j \cdot R_j \cdot v_j}{W}} \cdot (i + 1) \quad (9)$$

Where: W : 3.84 Mcps

E_b/N_0 : Energy per bit over total noise

R : Data rate

i : Interference between users

v : Activity factor

N : Number of active users

The capacity limiting factor in the downlink is the total Node B available power.

$$BS_{TxP} = \frac{N_{rf} \cdot W \cdot L \cdot \sum_{j=1}^N v_j \frac{(E_b/N_0)_j}{W/R_j}}{1 - \eta_{DL}} \quad (10)$$

$$\eta_{DL} = \sum_{j=1}^N v_j \frac{(E_b/N_0)_j}{W/R_j} \cdot ([1 - \alpha] + i) \quad (11)$$

Where:

BS_{TxP} : Total Transmission Power

η_{DL} : DL load factor

N_{rf} : Noise Density

α : Orthogonality factor

The interference margin is a unique parameter in the link budget that is directly related to the load of the cells. It can be expressed as a Noise Rise:

$$NR = 10 \cdot \log\left(\frac{1}{1-\eta}\right) \tag{12}$$

The noise rise limits the maximum allowed propagation loss between UE and Node B. If the load is close to 100%, the NR tends to infinite so the cell shrinks and the system becomes unstable.

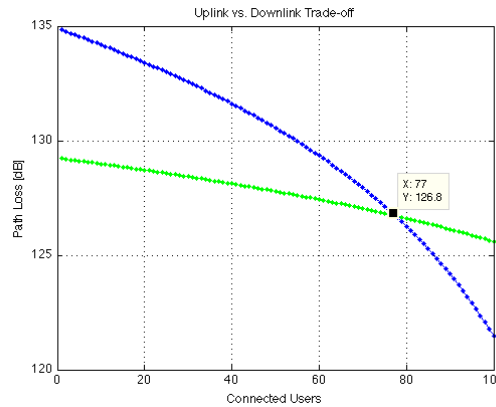

Figure 5: Uplink and Downlink Balance

As we can observe in figure 5, with the maximum expected load, the system is dimensioned to satisfy a certain amount of users, which implies a static configuration, since the assigned cell power stays fixed.

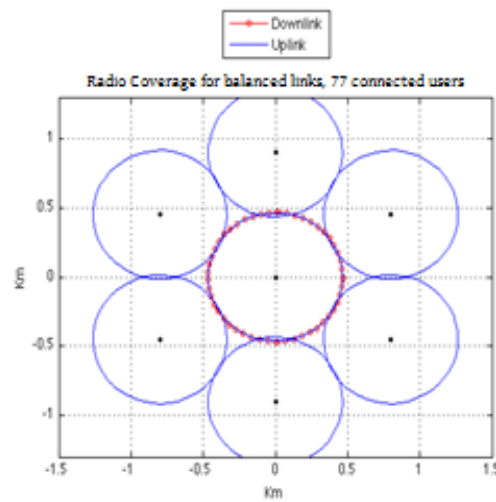

Figure 6: Expected coverage for peak hour traffic.

Given these considerations classical planning dimensions the system for a balance point, where as a function of a maximum expected load and a level of interference in the cell, we get a coverage range that guarantees the QoS. This relationship is shown in figure 6.

4 Proposed Power Control and Simulation Results

4.1 Power Control Mechanism

Because of the nature of mobile communications it is understandable that there is a difference between the network static dimensioning for the expected peak traffic and the real traffic flow in the network as we can see in figure 7.



Figure 7: Expected and real traffic variation

This load behavior generates a variation on the expected network interference, hence the cell radio varies accordingly (9) and (11).

As shown in figure 8, in low traffic load periods, because of the interference limiting issue, the cell range or coverage increases, invading with a high interference power neighboring cells. On the other hand, in certain periods when there is a high traffic load, that is more than the expected load, the cell range decreases generating coverage holes. This variations lead to three problems:

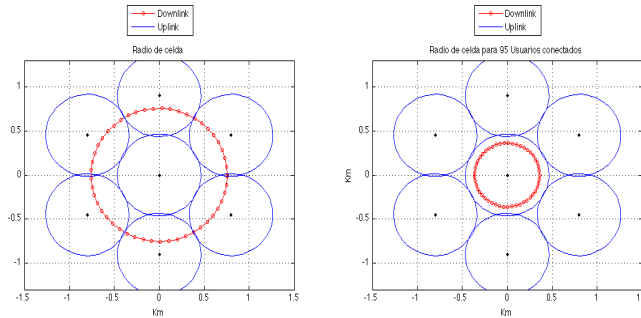

Figure 8: Coverage variation for low and high traffic load.

- Interference pollution to other cells (Pilot Pollution).
- Coverage holes appear and with them call drop and call setup problems.
- A waste of energy.

To deal with these problems we propose a simple algorithm to adjust the power allocation.

$$N = E[A(t)]: \text{Traffic Load Function} \quad (13)$$

$$L_{DL}[N] = EIRP - Sens_{RX} - Loss - IM \quad (14)$$

$$L_{UL}[N] = EIRP - Sens_{RX} - Loss - IM \quad (15)$$

$$L_{DL}[N] \cong L_{UL}[N] \mp N_{target}$$

$$L_{DL}[N] = (P_{TX} - \Delta(\eta_{DL}) + gain + loss) - Sens_{RX} - Loss - IM \quad (16)$$

Applying (12) on (16):

$$L_{DL}[N] = (P_{TX} - \Delta(\eta_{DL}) + gain + loss) - Sens_{RX} - Loss + 10 \log \left[1 - \left(N \cdot \frac{v \cdot \frac{E_b}{N_0}}{W} \right) \cdot [(1 - \alpha) + i] \right] \quad (17)$$

$$L_{DL}[N] = (P_{TX} - \Delta(\eta_{DL}) \pm \Delta P + gain + loss) - Sens_{RX} - Loss + 10 \log \left[1 - \left(N \cdot \frac{v \cdot \frac{E_b}{N_0}}{W} \right) \cdot [(1 - \alpha) + i] \right] \quad (18)$$

In (18) we define ΔP as the necessary power adjustment parameter that is calculated in an incremental way.

```

if N<Ntarget*0.10
  Power=Power*0.2;
elseif N<Ntarget*0.25 && N>Ntarget*0.10
  Power=Power*0.3;
elseif N<Ntarget*0.50 && N>Ntarget*0.25
  Power=Power*0.5;
elseif N<Ntarget*0.75 && N>Ntarget*0.50
  Power=Power*0.7;
elseif N<Ntarget*0.90 && N>Ntarget*0.75
  Power=Power*0.8;
elseif N<Ntarget*0.99 && N>Ntarget*0.90
  Power=Power*0.9;
elseif N>Ntarget&& N<Ntarget*1.1
  Power=Power*1.2;
elseif N>Ntarget*1.1 && N<Ntarget*1.3
  Power=Power*1.3;
elseif N>Ntarget*1.3 && N<Ntarget*1.5
  Power=Power*2;
end

```

Figure 9: ΔP Adjustment algorithm.

4.2 Simulation Results

In figure 10, we observe that by applying the power adjustment mechanism it is possible to modify and adjust the power used by the cell, reducing the cell overshooting or shrinking, and so offering a more suitable cell coverage since the uplink and downlink are more balanced.

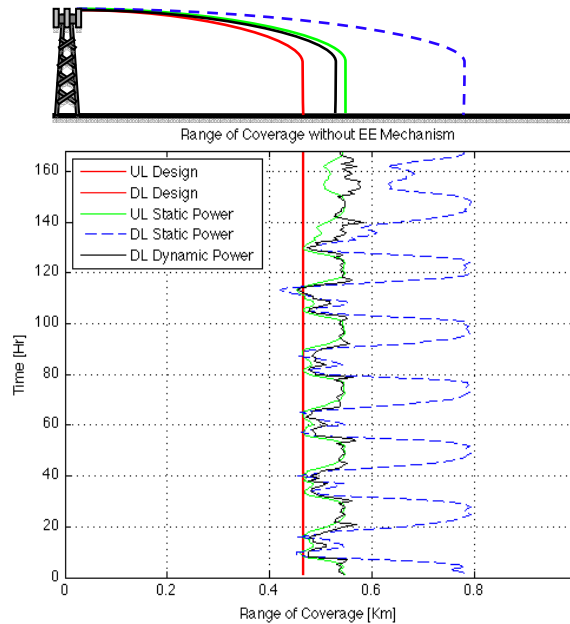

Figure 10: Radio Coverage Adjustment by the forecasted traffic.

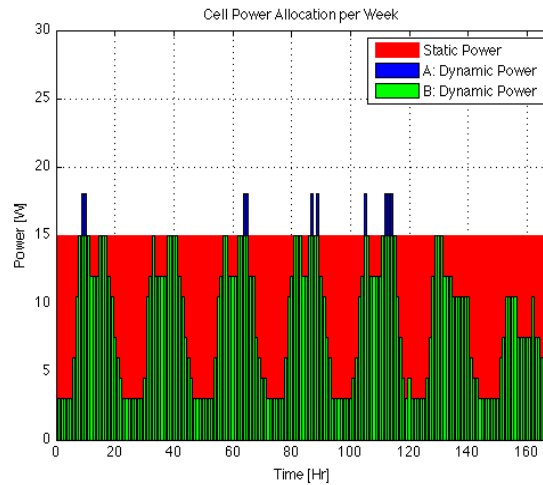

Figure 11: Energy Saving

Despite the cell overshooting reduction, there are still some time intervals where the cell radio is a bit bigger than expected.

As shown in figure 11, let us correct the amount of power needed in time intervals when there is too much power for the number of connected users (B: Dynamic Power). So reduces the available power. When there are more users than expected the adjustment power control increases the available power in order to attend those extra users (A: Dynamic Power).

In figure 11 we can observe that by applying a power adjustment mechanism the system can reach a 41.3% reduction in the weekly power consumption.

To study the consequences of this energy saving mechanism on the network performance, we analyze the received power of the pilot channel CPICH.

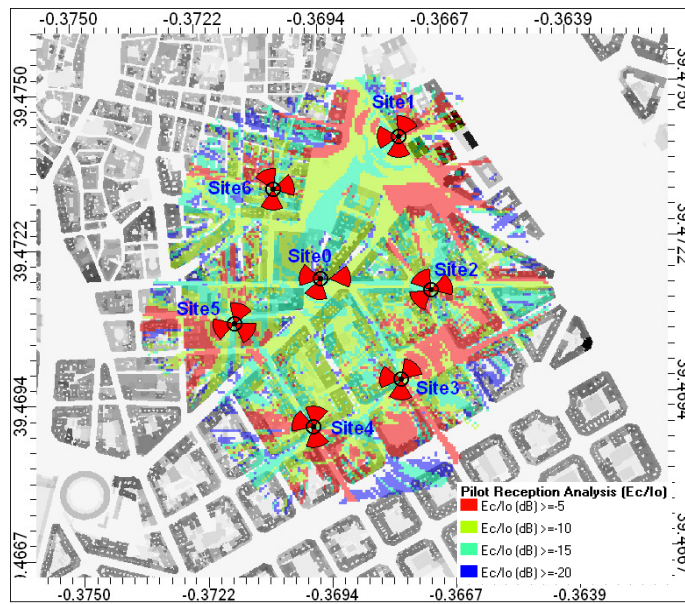

Figure 12: RSCP CPICH Static Power

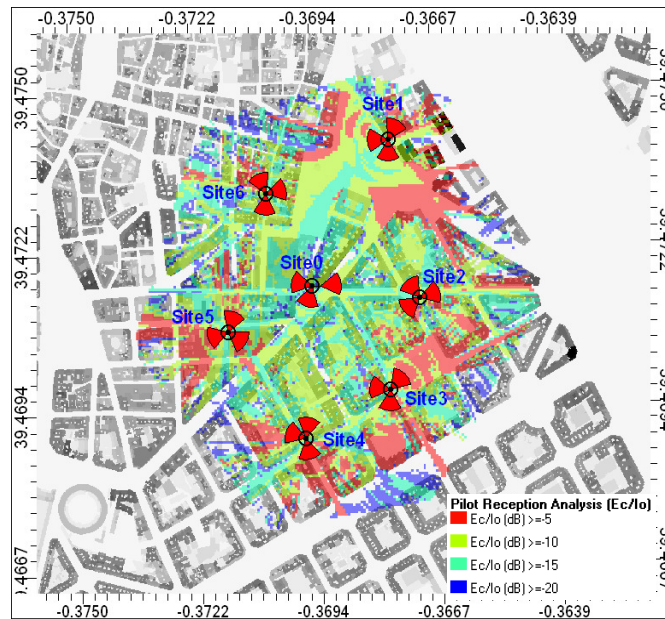

Figure 13: RSCP CPICH Dynamic Power

In figure 14 we see that if we reduce the available power by 50% the coverage area is at a minimum (shown in green), but the reception of the pilot channel can still offer a QoS (figure 12, 13).

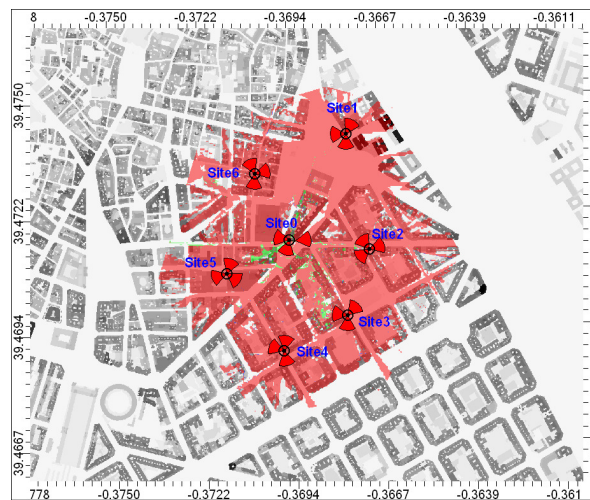

Figure 14: Effective Service Area

5 Conclusions

We have shown that by employing a simple transmitted power adjustment mechanism we have significant energy saving improvements and we mitigate certain network performance problems. Considering that the new mobile technologies tend to be faster on signaling, it is necessary that the additional processing for traffic forecasting doesn't demand excessive computational costs. Finally we would like to point out that it is important to continue with research on new mechanisms to minimize the energy consumption by mobile networks and for the UE.

References

- [1] E. Oh, B. Krishnamachari, "Energy Savings through Dynamic Base Station Switching in Cellular Wireless Access Networks", IEEE Globecom, 2010.
- [2] F. Hossain, S. Munasinghe, A. Jamalipour, "An Eco-Inspired Energy Efficient Access Network Architecture for Next Generation Cellular Systems", IEEE WCNC, 2011.
- [3] Z. Niu, Y. Wu, J. Gong, "Cell Zooming for Cost-Efficient Green Cellular Networks", IEEE Communications Magazine November, 2010
- [4] 3G Americas. "The benefits of SON in LTE. Self-Optimizing and Self-Organizing Networks", December, 2009.

- [5] NGMN white paper, “NGMN Recommendations of SON and OAM Requirements”, December, 2008.
- [6] E3: “Self-x in radio Access Networks”, December, 2008.
- [7] 3G Americas. Op.cit.
- [8] 3GPP TS 36.300 v.8.5.0, “3GPP E-UTRA & E-UTRAN”, Overall description, Stage2, Rel. 8.
- [9] E. Mino, E. Torrecilla, L.M.del Apio, “SON Use Case Study Energy Saving for LTE eNBs”, IEEE Latin America Transactions, 2010.
- [10] X. Weng, D. Cao, Z. Niu, “Energy-Efficient Cellular Network Planning under Insufficient Cell Zooming”, IEEE Vehicular Technology Conference, 2011.
- [11] Z. Niu, Y. Wu, J. Gong, “Cell zooming for cost-efficient green cellular networks”, IEEE Communications Magazine, 2010.
- [12] B. Badic, T. O’Farrell, P. Loskot, J. He, “Energy Efficient Radio Access Architectures for Green Radio: Large versus Small Cell Size Deployment”, IEEE Vehicular Technology Conference Fall, 2009.
- [13] Y. Chen, S. Zhang, S. Xu, “Fundamental Trade-offs on Green Wireless Networks”, IEEE Communications Magazine, 2011.
- [14] H. Holma, A. Toskala, LTE For UMTS Evolution to LTE Advanced, John Wiley & Sons, 2011.
- [15] J. Ramiro, K. Hamied, “Self-Organizing Networks (SON): Self-Planning, Self-Optimization and Self-Healing for GSM, UMTS and LTE”, John Wiley & Sons, 2011.
- [16] M.A. Marsan, L. Chiaraviglio, D. Ciullo, “Optimal Energy Savings in Cellular Access Networks”, IEEE International Confernece on Communications, 2009.
- [17] 3GPP work items on Self-Organizing Networks v0.0.7 (2011-02). Available at http://www.3gpp.org/ftp/Information/WORK_PLAN/Description_Relases/
- [18] ETSI TS 102 706 V1.2.1 (2011-10). Available at http://www.etsi.org/deliver/etsi_ts/