

9-1992

Multiple Endocrine Neoplasia Type 2B: Eighteen-Year Follow-up of a Four-Generation Family

Glen W. Sizemore

J. Aiden Carney

Hossein Gharib

Charles C. Capen

Follow this and additional works at: <https://scholarlycommons.henryford.com/hfhmedjournal>



Part of the [Life Sciences Commons](#), [Medical Specialties Commons](#), and the [Public Health Commons](#)

Recommended Citation

Sizemore, Glen W.; Carney, J. Aiden; Gharib, Hossein; and Capen, Charles C. (1992) "Multiple Endocrine Neoplasia Type 2B: Eighteen-Year Follow-up of a Four-Generation Family," *Henry Ford Hospital Medical Journal* : Vol. 40 : No. 3 , 236-244.

Available at: <https://scholarlycommons.henryford.com/hfhmedjournal/vol40/iss3/21>

This Article is brought to you for free and open access by Henry Ford Health System Scholarly Commons. It has been accepted for inclusion in Henry Ford Hospital Medical Journal by an authorized editor of Henry Ford Health System Scholarly Commons.

Multiple Endocrine Neoplasia Type 2B: Eighteen-Year Follow-up of a Four-Generation Family

Glen W. Sizemore,* J. Aidan Carney,† Hossein Gharib,† and Charles C. Capen‡

Seven members with multiple endocrine neoplasia type 2B from a 15-member family have been followed for 18 years. All affected had the neuroma phenotype in a distribution compatible with autosomal dominant inheritance. The phenotype features have allowed 100% initial and continuing prediction of affected versus nonaffected status in as early as 1.5 years. Among the affected: immunoreactive plasma calcitonin (iCT) concentration was high in 100%; thyroid palpation was false-negative in 71%; and thyroid scintiscan was false-negative in 83%. All had total thyroidectomy, plus lymphadenectomy in three, for bilateral medullary thyroid carcinoma (MTC) or C-cell hyperplasia (in the youngest). None has died directly from MTC. The index case died at age 68 and his son at age 32 years from complications of the syndrome. All but the youngest have continuing high iCT concentrations. No patient has had parathyroid disease. During preoperative calcium infusion, immunoreactive serum parathyroid hormone concentration declined by 35% to 84% of basal. At operation, macroscopically and microscopically normal parathyroid glands were found in all. No patient has had chemical suggestion of pheochromocytomas: at postmortem the index case had no adrenal medullary disease; his son had bilateral nodular adrenal hyperplasia; his daughter has had adrenal medullary hyperplasia and a renin-secreting juxtaglomerular tumor. Initially nonaffected members remain so. (Henry Ford Hosp Med J 1992;40:236-44)

Multiple endocrine neoplasia type 2 (MEN 2) is a designation that was proposed by Steiner et al (1) in 1968 for the association of medullary thyroid carcinoma (MTC), pheochromocytoma, and parathyroid disease in patients with normal appearance. The eponym Sipple's syndrome (2) has been applied. After the first complete report of one case by Manning et al (3) in 1963, numerous families with this syndrome were reported (4-7).

In 1922 Wagenmann (8) reported the case of a 12-year-old boy with neuromas on the eyelids and tongue and a general facial appearance similar to that of our patients. This is probably the first reported example of a variant of MEN 2 which has a distinct ganglioneuroma phenotype, MTC, pheochromocytoma, and rare parathyroid disease (9). By the mid 1970s, more than 60 patients with this variant had been recognized and/or reported,§ including the families reported by Bartlett and colleagues (10) and Khairi et al (11). To preserve the basic set of tumors in one group and yet recognize the subtle differences between the two variants, our group contrasted patients with the normal phenotype as having MEN 2A and those with the ganglioneuroma phenotype as MEN 2B (12). To emphasize the marfanoid habitus, mucosal neuromas, and infrequent parathyroid disease of the variant, Khairi et al (11) proposed the label "MEN type 3."

We report observations of members of this largest family with MEN 2B to: 1) share a perspective of their disease which is offered by 16-19 years of follow-up, 2) emphasize the pattern of inheritance of the syndrome, 3) substantiate the need for early diagnosis and treatment of the MTC, 4) outline the utility of se-

quential measurement of plasma immunoreactive calcitonin (iCT) concentrations for diagnosis and management of the MTC component, 5) show that parathyroid disease is rare in affected patients, and 6) question whether other patients with MEN 2B might have renin-secreting renal tumors.

Patients and Methods

We studied 15 members of a family (Fig 1) at risk for the syndrome. Other members of the family were said to have normal appearance; they have not been examined. For comparisons, the calcium infusion test was done in a group of 10 healthy adults, age 24 to 44 years, without thyroid or parathyroid disease, and the intradermal skin test was done in five healthy adults, age 23 to 31 years.

Clinical studies

For all studied family members, clinical studies included a complete history and physical examination, routine laboratory studies, thoracic roentgenogram, ECG, and thyroid scintiscans

Submitted for publication: October 14, 1991.

Accepted for publication: January 27, 1992.

*Department of Medicine, Loyola University Stritch School of Medicine, Maywood, IL.

†Department of Medicine, the Mayo Clinic, Rochester, MN.

‡The Department of Veterinary Pathobiology, Ohio State University, Columbus, OH.

§References for these cases are available upon request.

Address correspondence to Dr. Sizemore, Section of Endocrinology (Bldg 117), Loyola University Medical Center, 2160 S First Ave, Maywood, IL 60153.

with ^{99m}Tc . The serum calcium, phosphorus, plasma alkaline phosphatase, catecholamines, urinary fractionated and total catecholamines, and total metanephrines were measured in all affected members (13-18).

iCT concentration was measured sequentially through the duration of the study in three separate radioimmunoassays (19-23); iCT concentration was measured after pentagastrin (20) in some patients; and iCT concentration and immunoreactive serum parathyroid hormone (iPTH) concentration (24) were measured in all family members and controls before and during calcium infusion. Calcium, as calcium gluceptate (Lilly), was infused intravenously for 4 hours; the dosage was 15 mg Ca^{++} /kg in 250 mL (for children) or in 500 mL of 0.9% NaCl. Glucagon provocation tests for pheochromocytoma were done by the method of Lawrence (25) and Sheps and Mayer (26) with 1.0 mg of crystalline glucagon (Lilly). Plasma catecholamine concentrations were measured before and at 1 and 3 minutes after glucagon administration. For the intradermal histamine skin tests, 0.1 mL intradermal injections of a 1:100,000 dilution of histamine phosphate in 0.9% NaCl were given on the backs of all subjects; 0.1 mL of 0.9% NaCl was given as a control. At 5 and 30 minutes, the maximal diameter and a second diameter, at 90° to the first, of the wheal and the flare were measured.

Light and electron microscopy

Tissue for light microscopy from all affected family members was prepared by fixation in 10% buffered formalin and routine paraffin embedding. Sections were stained with hematoxylin and eosin, methyl violet, and thioflavin T.

Multiple blocks of thyroid and parathyroid were prepared for electron microscopy. The tissue was cut into 1 mm cubes under fixative immediately after surgical excision and fixed at ice temperature for approximately two days in 3% glutaraldehyde in 0.2 M sodium cacodylate. Postfixation was accomplished in 1.33% osmium tetroxide with *s*-collidine at pH 7.4. The blocks were dehydrated in increasing concentrations of ethanol and embedded in Epon (Shell Oil Co., New York, NY). Sections were cut at 50 nm (0.05 μm) with diamond knives on a Reichert Om U2 ultramicrotome and mounted on 200- and 400-mesh copper grids. The sections were stained with uranyl acetate and lead citrate and examined with a Philips 300 electron microscope.

Results

The index case

This 51-year-old patient (Fig 1, II-2; Fig 2, first photo) was first seen at the Mayo Clinic because of symptoms of keratoconjunctivitis sicca. He had had ganglioneuromas on his tongue and eyelids since childhood. He experienced flushing after alcohol ingestion.

The patient weighed 91.3 kg (203 lbs). His height was 5'6", span 71.5", lower segment 35". His blood pressure was 145/90 mm Hg and pulse 88 beats/min. He had a marfanoid habitus but was a stocky gentleman. He had a tall and narrow hard palate, a fleshy lower lip, and had ganglioneuromas on the anterior tongue and both arytenoid cartilage areas and lower tarsal mar-

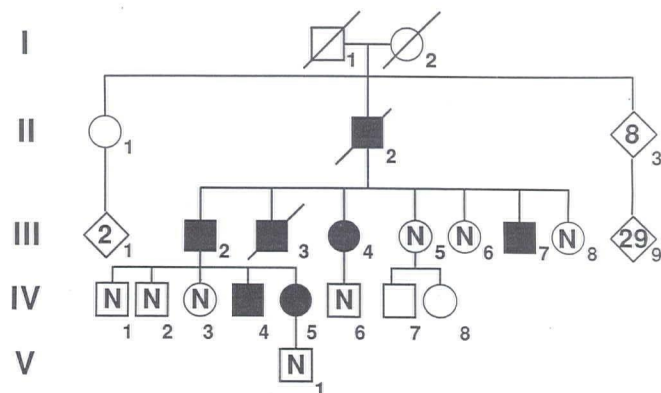

Fig 1—Pedigree of family. Solid square or circle = affected male or female member with ganglioneuroma phenotype and medullary thyroid carcinoma; boxed or circled N = unaffected studied members; blank square or circle = members presumably not affected but not studied; number within diamond = number of other members whose status is unknown; solid square or blank circle with diagonal line = deceased affected male or deceased nonaffected female members.

gins. His face was plethoric with multiple fine telangiectases and a large, red, fleshy nose characteristic of rosacea. There were thick corneal nerve fibers. Thyroid and cervical area palpation was normal. He had a left inguinal hernia, bilateral clinodactyly of the terminal phalanges of both fifth fingers, and a moderate degree of bilateral pes cavus.

During calcium infusion his basal iCT concentration rose from 22.2 ng/mL (5,700% maximal basal) to 122 ng/mL (29,000% maximal stimulated) (Fig 3) and his iPTH concentration declined from 44 to 20 $\mu\text{L eq/mL}$ (Fig 4). A ^{99m}Tc thyroid scintiscan was normal. A total en bloc thyroidectomy was done in March 1972. No lymphadenopathy was detected in the tracheoesophageal groove, the anterior mediastinum, or the lateral neck, so the operation was not continued beyond the thyroid bed. The thyroid weighed 28 g and measured 5 × 4 × 2.5 cm. Bilateral grade II MTC was found forming well-circumscribed invasive masses in the superior portion of the right lobe (2 × 1.7 × 1.3 cm) and in the superior portion of the left lobe (3 × 2.4 × 1.5 cm) as well as bilateral C-cell hyperplasia. All parathyroid glands were macroscopically normal.

During the next 17 years his iCT concentration ranged between 2.0 and 2.65 ng/mL. He developed no symptoms of pheochromocytoma, had normal blood pressures, and had normal 24-hour urinary contents of epinephrine (2.2 to 6 μg), norepinephrine (17 to 70 μg), and total metanephrine (0.6 mg).

During his last five years he was troubled with dysphagia, required repeated esophageal dilatations, and placement of a gastroscopy tube. He developed ischemic colitis, a "toxic megacolon," and had laparotomy with subtotal colectomy and ileocolic anastomosis. The latter ulcerated and he developed peritonitis, sepsis with shock, a necrotizing bronchopneumonia, and acute respiratory distress syndrome and died in January 1989. No MTC or pheochromocytoma was found postmortem.

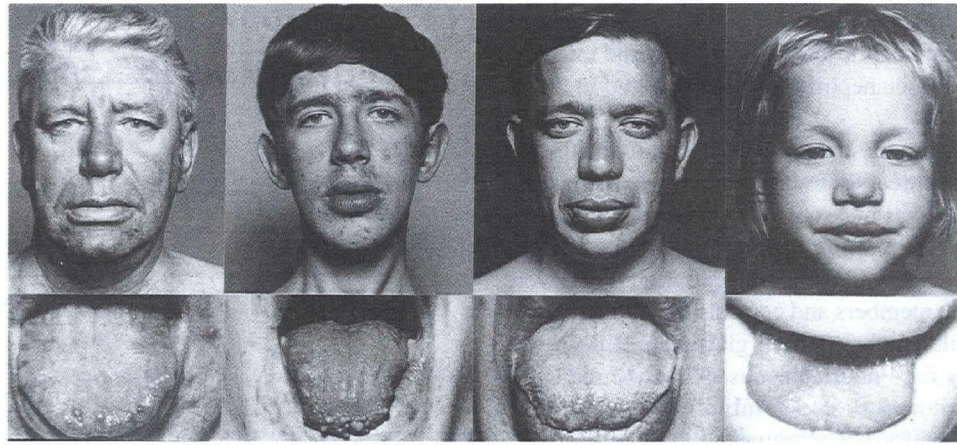

Fig 2—Abnormal facies, thickened lips, and ganglioneuromas of tongue in four affected members of the family. From left to right: II-2 (index case), III-7, III-2, IV-5. (From Sizemore GW, et al. *Clin Endocrinol Metab* 1980;9:299. Reprinted with permission.)

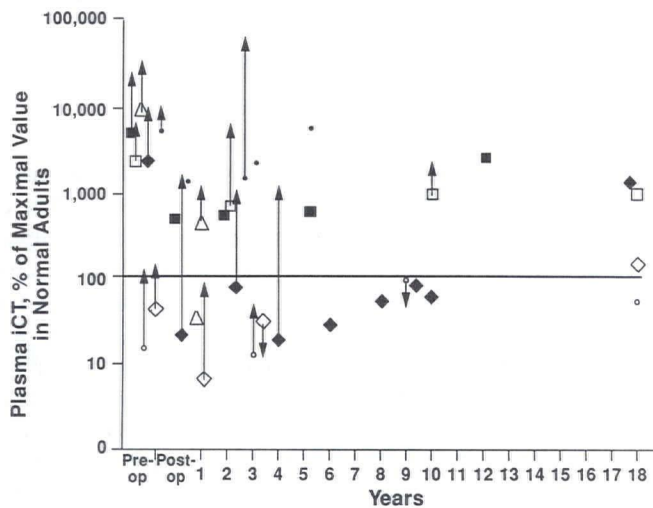

Fig 3—Sequential iCT concentration in the seven affected members. Log plotted patient values are expressed as the percent of maximal normal iCT concentration in healthy adult men or women in the calcitonin radioimmunoassay used at the time of study. Basal values generally are lower than stimulated values. Triangle = maximal value during calcium infusion or after pentagastrin injection. Values below the 100% line are normal. Solid square = II-2; blank square = III-2; blank triangle = III-3; solid diamond = III-4; solid circle = III-7; blank diamond = IV-4; blank circle = IV-5.

Family characteristics

All of the 14 other members of the family felt well initially and, with minor exceptions, were asymptomatic. None had noted thyroid enlargement, hoarseness, neck pain, or cervical lymphadenopathy. None had symptoms suggesting pheochromocytoma, hyperparathyroidism, duodenal ulcer, myopathy, Cushing's syndrome, acromegaly, or functioning pancreatic tumor. Three members (III-2, III-7, and IV-5) had diarrhea alter-

nating with constipation. A subtotal colectomy had been performed in III-3 for functional megacolon that was associated with hyperplastic myenteric nerve plexuses.

Seven members had the ganglioneuroma phenotype (Fig 2) consisting of thickened lips, asymptomatic ganglioneuromas of the tongue, thickened corneal nerve fibers, and increased joint laxity (Table 1). Eight other members were normal. All affected adults had a marfanoid habitus (long, slender body build with relatively long extremities). Other abnormalities, each noted in one affected person, were facial telangiectases, arachnodactyly, digital camptodactyly, and talipes equinovarus. No member had tracheal deviation or compression, laryngeal paralysis, cervical lymphadenopathy, cafe au lait spots, neurofibromas, myopathy, gynecomastia, or local or generalized hyperpigmentation.

The thickened lips with irregular mucosal surfaces were caused by the presence of multiple ganglioneuromas (biopsy in III-3) in the subepithelial connective tissue. Visible ganglioneuromas, 0.2 to 0.7 cm in diameter, were present on the tongue (seven members), buccal mucosa (four members), eyelids (four members), subconjunctiva (four members), and arytenoid cartilage (two members). They were composed of unencapsulated masses of convoluted nerves without significant fibrous tissue. Their histologic appearance simulated that of traumatic ganglioneuromas rather than neurofibromas.

All affected members had abnormal ophthalmologic findings. Markedly prominent corneal nerve fibers extended in a lace pattern across the entire cornea. Although these nerves were invisible to the unaided eye, when viewed with the slit-lamp biomicroscope their large size and pattern were obvious and distinct from normal. Enlarged nerves were also commonly seen in the subconjunctival regions where they sometimes caused elevation of the overlying tarsal or bulbar conjunctiva. On either side of the corneal limbus, these nerves were either solitary or in bundles that appeared as flat, poorly delineated neuromas. Dilated perilimbal conjunctival blood vessels often were associated with these paralimbal neuromas, and members with these findings complained of chronically red eyes. In older family members, decreased tear flow produced symptoms of kerato-

Table 1
Occurrence of Physical Features of the Phenotype

Abnormality	Family Member						
	II-2	III-2	III-3	III-4	III-7	IV-4	IV-5
Thick lips	+	+	+	+	+	+	+
Ganglioneuromas	+	+	+	+	+	+	+
Prominent corneal nerves	+	+	+	+	+	+	+
Increased joint laxity	+	+	+	+	+	+	+
Marfanoid habitus	+	+	+	+	+	+	+
Dolichocephaly		+	+	+	+		
Dorsal scoliosis		+		+	+		
Pectus excavatum			+		+		
Pes cavus		+		+			

conjunctivitis sicca, and there were thickenings or irregular prominences along the free margins of the lid caused by the abnormal nerves. None of these ophthalmologic findings was present in normal family members.

Response to histamine

All seven affected had an attenuated response to intradermal histamine injection; the diameters of the flare responses varied from 0 to 1.2 cm and from 0 to 1.3 cm at 5 and 30 minutes, respectively. In the five normal controls the flare diameters varied from 3.5 to 6.5 cm and from 2.5 to 4.5 cm at 5 and 30 minutes, respectively. Intradermal injection of saline produced no flare in the five normal controls, in seven affected members, or in three nonaffected members. Three nonaffected family members (III-5, 6, 8) had flare responses identical to those in the controls.

Routine laboratory studies

The following studies gave normal results in all patients: hemoglobin concentration, leukocyte total and differential counts, urinalysis, fasting plasma glucose, plasma creatinine, serum total thyroxine, plasma total protein, serum phosphate, plasma alkaline phosphatase, thoracic roentgenogram, and ECG. All family members had normal serum calcium concentrations except II-2 who had consistently low concentrations, ≤ 8.7 mg/dL (normal 8.9 to 10.1 mg/dL). Roentgenographic abnormalities were present in three patients: III-2 had a grossly dilated stomach without ulcer or outlet obstruction; III-7 had a megacolon; and III-3 had anomalous L3-5 vertebral bodies with a markedly increased anteroposterior diameter.

Medullary Thyroid Carcinoma

Thyroid palpation and scintiscan

Thyroid palpation suggested the presence of bilateral tumor in III-4 and unilateral tumor in III-2 and III-3; it was normal in four additional affected members (Table 2). No patient had palpable lymph nodes suggesting metastasis. All seven affected patients were subsequently shown to have bilateral MTC or C-cell hyperplasia; thus, palpation was incorrect in 71% of 14 affected lobes. The diameter of tumors not detected was 0.3 to 2.4 cm. Scintiscans of the thyroid gland were done in six of the seven affected patients. Unilateral tumor was detected in III-2 and III-4.

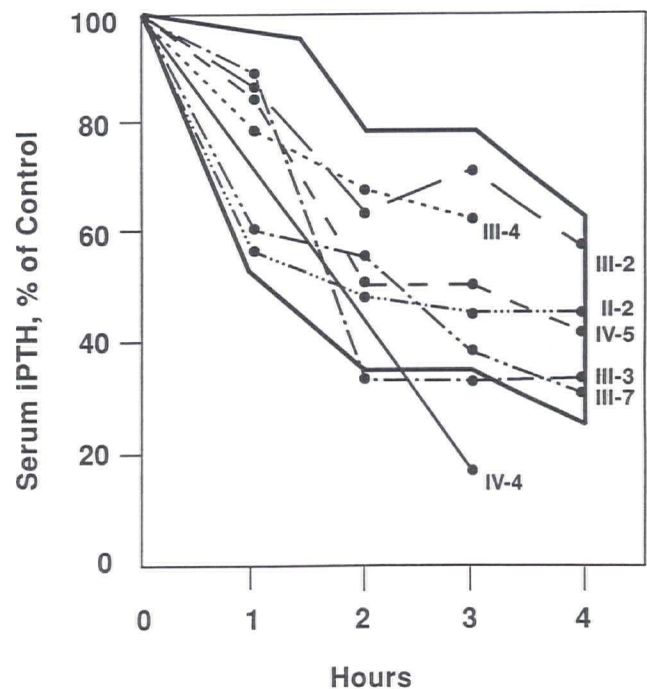

Fig 4—Serum iPTH concentration, as percent of control, during calcium infusion (15 mg/kg over 4 hrs) in seven affected family members (•) and ten normal controls (range shown by outlined area).

However, tumor was not detected in 83% of the 12 affected lobes that were scanned. The diameter of tumors not detected by scintiscan was 0.3 to 3.0 cm. The thyroid gland palpation and scintiscans (III-5, 6, 8) were normal in nonaffected members.

Calcitonin

Over the duration of this study three separate immunoassays were used to measure iCT in family members and controls. During the initial phase, the upper 95% confidence limit for basal iCT concentration in healthy adults in our immunoassay was 0.39 ng/mL, and the immunoassay could not measure iCT concentrations below 0.05 ng/mL (19,20). iCT concentrations did

Table 2
Summary of Clinical, Hormone Assay, and Pathologic Findings

Case	Age/Sex/ Date*	Thyroid Palpation & Scan	Basal iCT†	Basal Calcium‡	Basal IPTH§	Pathology	Latest Information
II-2	51/M/ 1972	Both normal	22.20	8.7	44	Bilateral MTC; 2 x 1.7 x 1.3 cm R; 3 x 2.4 x 1.5 cm L; parathyroid glands grossly normal.	Died 1989. Peritonitis with septic shock and acute respiratory distress syndrome after subtotal colectomy and ileocolic anastomosis for ischemic colitis. No MTC or adrenal medullary disease at postmortem.
III-2	32/M/ 1972	1.5 cm nodule L.U. pole; nodule "cold"	9.60	9.1	14	Bilateral MTC: 1.2 x 1.2 x 1 cm R; 2.5 x 1.5 x 1 cm L. Metastatic tumor, 2 L. tracheoesophageal & 2 L. jugular lymph nodes; parathyroid glands grossly normal.	1991. Treated hypertension. Symptoms consistent with pheochromocytoma. Myopathic and gastrointestinal problems.
III-3	30/M/ 1972	3.0 cm nodule L. lobe; no scan	37.80	9.8	15	Bilateral MTC: Four 3- 8 mm nodules R; four 0.4-3.5 x 2.7 x 2 cm nodules L. Parathyroid glands normal.	Died 1973. Cardiopulmonary arrest caused by cervical hemorrhage after secondary cervical exploration. No MTC but bilateral nodular adrenal medullary hyperplasia.
III-4	26/F 1972	3 cm nodule R. lobe; 2 cm nodule L. lobe; R. nodule "cold"	9.75	9.4	24	Bilateral MTC: 3 x 2 x 2 cm R; 1 x 1 x 1 cm L. L. inferior parathyroid gland normal.	1991. Well. 1981 L. nephrectomy for renal juxtaglomerular tumor and L. adrenalectomy for adrenal medullary hyperplasia.
III-7	18/M/ 1972	Both normal	25.00	10.0	16	Bilateral MTC: 1.2 cm R; 0.8 cm L; metastatic tumor, 2 R. paratracheal and 8 and mediastinal lymph nodes. Parathyroid glands grossly normal.	1991. Well.
IV-4	7.3/M/ 1973	Both normal	0.15	9.6	12	Bilateral MTC: 0.3 cm R; 0.5 cm L. L. inferior parathyroid gland normal.	1991. Well. Keratoconjunctivitis
IV-5	1.8/F/ 1973	Both normal	0.06	9.7	5	Bilateral multicentric C-cell hyperplasia. R. inferior parathyroid gland normal.	1991. Well.

*Age in years. Date = initial thyroidectomy or evaluation.

†Normal ≤ 0.39 ng/mL.

‡Normal = 8.9-10.1 mg/dL.

§Normal ≤ 38 μL eq/mL.

not exceed 0.42 ng/mL during calcium infusion or after pentagastrin injection in the 10 normal adult controls in this study. From July 1978, the maximal iCT concentration in normal adult men/women was: basal, 0.155/0.105; calcium infusion, 0.265/0.120; and pentagastrin injection, 0.210/0.105 ng/mL. From January 1986, the maximal iCT concentration in normal adult men/women was: basal, 20/17; calcium infusion, 190/130; and pentagastrin injection, 260/33 pg/mL.

Before thyroidectomy, basal iCT concentration was high in five affected members and normal in the two affected children (Table 2, Fig 3); iCT concentration increased above the normal range during calcium infusion in all affected members. In nonaffected members, the iCT concentration did not exceed normal limits before or during calcium infusion. After total thyroidectomy, the iCT concentration was high before or during

calcium infusion or pentagastrin injection in five affected members and was normal in two (IV-4 and IV-5).

Pathology

All seven affected members had primary total thyroidectomy. Additional primary surgical treatment was required in three members when frozen section disclosed metastases in regional lymph nodes: III-2 and III-3 had modified neck dissections for regional neck metastases, and III-7 had a mediastinal lymph node dissection and thymectomy for mediastinal metastases.

Six of the seven thyroid glands contained grossly visible bilateral MTC in the upper poles. The tumors, ranging from 0.3 to 3.0 cm in diameter, were circumscribed but not encapsulated. Smaller "satellite" tumor nodules adjacent to the large tumors were occasionally present. Microscopically, all of the tumors

contained neoplastic cells with features characteristic of the C-cells in MTC. In IV-5, multicentric parafollicular cell clusters were the only abnormality; this microscopic appearance is designated "C-cell hyperplasia" after Jackson et al (6) and Wolfe and coworkers (27).

Adrenal Medullary Disease

Initially, no member had symptoms of adrenal medullary hyperplasia (AMH) (28) or pheochromocytomas and all had normal blood pressure. All had normal values for total metanephrines which ranged between 0.3 and 0.85 mg (normal ≤ 1.3 mg) in at least one 24-hour urine sample and normal basal concentrations (≤ 32 ng/mL) of plasma catecholamines ranging between 6.3 and 19.2 ng/mL. The glucagon provocation test (25,26) did not induce pressor responses or abnormal concentrations of plasma catecholamines higher than in the controls (IV-1, IV-2, and IV-3 did not have this study).

During 17 years of follow-up, affected patient II-2 developed no symptoms or signs of AMH or pheochromocytomas. At post-mortem his adrenal glands were normal. He had had normal 24-hour urinary contents of epinephrine, norepinephrine, and dopamine two years before. After one-year follow-up, patient III-3 had bilateral nodular AMH, 0.5 cm R and 0.4 cm L at post-mortem. In the year before death he was normotensive and had normal urinary contents of total catecholamines, metanephrine, and 3-methoxy-4-hydroxy-D-mandelic acid (VMA) (29). After six years of follow-up, patient III-4 developed hypertension which continued for three years until left nephrectomy and adrenalectomy for a juxtaglomerular renal tumor and AMH. All preceding measurements of 24-hour urinary contents of epinephrine (2), norepinephrine (2), total catecholamines (5), metanephrine (6), and VMA (4) had been normal. After 19 years of follow-up, affected patient III-2 has developed hypertension and symptoms consistent with pheochromocytomas but still has normal 24-hour urine contents of fractionated catecholamines and metabolites. Other affected members are normal.

Parathyroid Disease

No affected or unaffected member has had or developed clinical parathyroid disease during this study. The basal iPTH concentrations in all affected and unaffected normocalcemic family members (Table 2) were normal (≤ 38 μ L eq/mL). The basal iPTH concentration of 44 μ L eq/mL in II-2 reflects the low serum calcium concentration. During the 4-hour calcium infusion, the iPTH concentration decreased by 35% to 84% of basal concentration in the seven affected members (Fig 4), a response similar to that in 10 normal adults but different from patients with MEN 2A who have been found to have occult parathyroid hyperplasia (30).

Parathyroid glands were identified in all patients at operation, and all were macroscopically normal. In several cases, one gland was removed for histologic study and others were biopsied (no patient became hypocalcemic postoperatively). On light microscopic examination in cases III-3, III-4, and IV-5, all findings were normal. Parathyroid glands from three family members (III-7, IV-4, IV-5) were examined by electron micros-

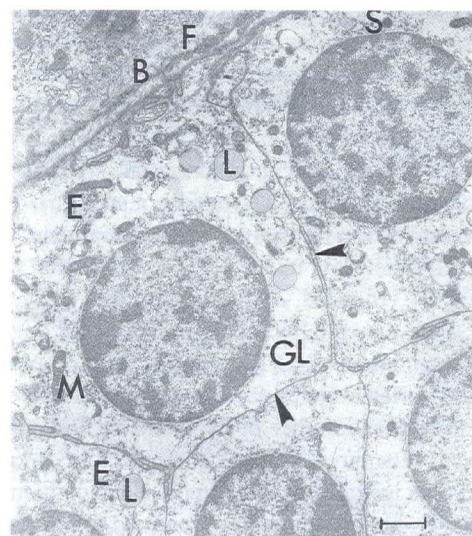
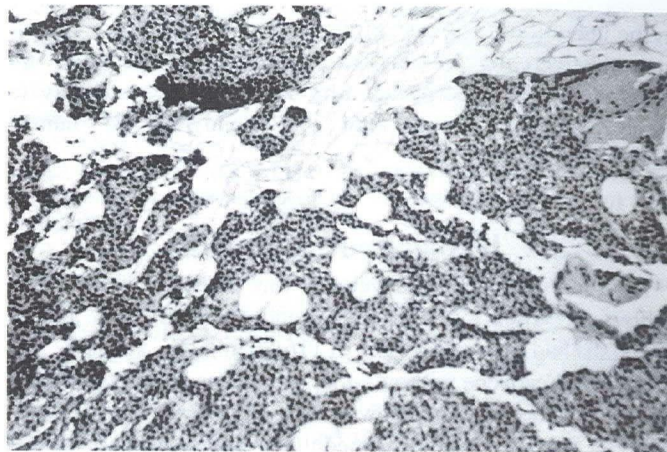

Fig 5—Top: Parathyroid gland (from III-3) showing predominantly chief cells and normal parenchymal replacement by adipose tissue (hematoxylin-eosin stain, X100). Bottom: Electron micrograph. Inactive chief cells in inferior parathyroid of family member (III-4). The cytoplasm contains abundant glycogen (GL), lipid bodies (L), dispersed profiles of endoplasmic reticulum (E), small mitochondria (M), and infrequent secretory granules (S). Plasma membranes of adjacent chief cells are relatively straight (arrowheads). B = basement membrane bordering perivascular space with collagen fibers (F) (scale represents 1 μ m).

copy. They had no ultrastructural evidence of chief cell stimulation or hyperplasia, and they were composed predominantly of chief cells in the inactive stage of the secretory cycle (Fig 5). Inactive chief cells were cuboidal and had numerous glycogen particles in the cytoplasm but poorly developed secretory organelles and infrequent secretory granules. The Golgi apparatus was small, and endoplasmic reticular membranes were dispersed. Plasma membranes of adjacent cells were straight and had relatively uncomplicated interdigitations. Active chief cells were observed infrequently, and oxyphil cells were not present in the parathyroids. Mature fat cells were observed occasionally

in the interstitium between groups of chief cells. The predominant inactive chief cells in parathyroids of these patients with MTC or C-cell hyperplasia were similar ultrastructurally to those reported in normal adult (31,32) and fetal (33) human parathyroid glands.

Juxtaglomerular Tumor

Affected patient III-4 developed this unusual tumor during follow-up. When initially studied and operated on at age 26 years, she had a blood pressure of 116/80 mm Hg. At age 32, she developed headache without other symptoms of catecholamine excess and blood pressures were 110/75, 147/98, and 160/110 mm Hg. Studies for adrenal medullary disease, urinalysis, and her serum potassium concentrations of 3.9 and 4.3 (3.5 to 4.5 mEq/L) were normal. A renogram demonstrated delayed wash-out on the right, and a bolus nephrotomogram showed a 3.0 cm parenchymal mass and 1.0 cm cyst in the lower pole of the left kidney. Angiography demonstrated minimal fibromuscular hyperplasia of both renal arteries and a 4.0 cm mass in the lower lateral left kidney with associated abnormal serpiginous vessels with arteriovenous shunting. The results of sodium depleted (20 mEq Na diet and 80 mg furosemide) differential renal vein renin measurements were: right renal vein, 14.9; left renal vein, 19.0; inferior vena, 14.3 (normal, 2.9 to 24 ng/mL/hr). She was treated with low sodium diet and hydrochlorothiazide for one year; her hypertension continued (150/102 mm Hg) and propranolol (60 mg twice daily) was required for control. She did not return for follow-up and had recurrence of hypertension and enlargement of the mass. Left nephrectomy and adrenalectomy were done at age 35 at another institution. The adrenal gland contained AMH. Postoperatively, her blood pressure returned to normal (120/84 mm Hg) and remains so.

The kidney weighed 230 g. Its lower pole was occupied by a soft, nonbulging, gray-white tumor that measured 7.0 × 5.0 × 5.0 cm. Light microscopy showed that a thick fibrous tissue capsule separated the tumor from the renal parenchyma. The neoplasm was composed of approximately equal parts of cells and stroma. Various shaped aggregates of tumor cells were separated from one another by the abundant, lightly eosinophilic and fibrillar stroma. The latter was markedly hypovascular with only scattered sinusoidal vessels present. With periodic-acid Schiff staining, the stroma showed fine, positively stained fibrils; it did not stain with the Van Gieson method for collagen.

The tumor cells were polymorphic but some were strap-like or elongated and tapering, with the nucleus polarized at the wide end of the cell. Where it was well-fixed, the cytoplasm was eosinophilic and contained minute, periodic-acid Schiff-positive granules aggregated in clumps or sometimes in longitudinal columns. Oil Red O-positive cytoplasmic bodies were present. In less well-fixed areas of the neoplasm, the cytoplasm showed decreased eosinophilia and often approached the staining quality of the stroma, so that distinction between the two became impossible. In places the appearance of the stroma was reminiscent of amyloid, but stains for that substance were negative.

The nuclei were moderate in size and polymorphic (but not spindle), many being prominently lobulated. They were moder-

ately hyperchromatic with speckled chromatin and inconspicuous nucleoli. Single or multiple intranuclear cytoplasmic protrusions (pseudoinclusions) were common. Scattered mitotic figures were present.

There was focal degeneration in the tumor. In these areas the tumor cells were vacuolated, and the stroma lost its eosinophilia and was loose and edematous. The kidney in the immediate vicinity of the tumor showed compression of the cortex and chronic interstitial nephritis.

Immunocytochemistry

The cytoplasm of the tumor cells gave a strong positive reaction with antirenin antiserum. Negative results were obtained with antisera to calcitonin, S-100 protein, and glial acidic protein.

Electron microscopy

The tumor cells were irregular in shape but often elongated. The plasmalemma formed a multitude of narrow, elongated, interdigitating processes, occasionally exhibiting narrow tight junctions. The cell processes ramified in copious basement membrane-like material. The nuclei were irregular in shape, exhibited marked folding, and encompassed cytoplasmic protrusions containing several types of cytoplasmic organelles. The Golgi apparatus was prominent and contained globular masses of electron-dense material. Rough endoplasmic reticulum coursed through the cytoplasm and, in a few cells, encompassed straight microtubular arrays. Mitochondria, some with myelin figures, were scattered in the cytoplasm. Many cells contained dense, membrane-limited secretory granules which were often localized to a particular portion of the cytoplasm. Vesicles, lipid-filled and empty, were frequently encountered. Lysosomes, microtubules, and cytoplasmic filaments were present.

Preoperative examination and test results in this patient showed that she had severe hypertension, a left renal tumor, and higher renin-activity in the left renal vein. Results of roentgenography of the adrenal glands and measurement of urinary excretion of catecholamines were normal. Left nephrectomy resulted in cure of the hypertension. Immunostaining demonstrated renin reactivity in the renal tumor, and by electron microscopy membrane-bound secretory granules were observed in tumor cells. Therefore, we think the patient's hypertension was due to her histologically unique renin-secreting tumor.

Discussion

The physical appearance of patients having the ganglioneuroma phenotype, C-cell hyperplasia, or MTC and adrenal medullary disease which we designated MEN 2B (12) is striking. In our patients the syndrome could be correctly diagnosed based on physical examination alone. The major features distinguishing these patients with MEN 2B from those with MEN 2A (the so-called Sipple syndrome) are the ganglioneuroma phenotype and absence of parathyroid disease. Although this study confirms that measurement of iCT concentration is useful for confirming the diagnosis, we think that clinicians knowledgeable

about MEN 2B can recommend thyroidectomy without such measurement. Although the affected children in this family had greater than normal stimulated iCT concentrations, their phenotype "allowed" operation. Operation based on phenotype alone has been done (11,34).

Familial aggregation

The pedigree of this family clearly demonstrates the heritability of this syndrome (Fig 1). Of the seven children of the index patient (II-2), four are affected. In generation IV, there are six children born to affected persons (IV 1-6) and, of these, two are affected. Thus, 6 of 13 children of affected persons are affected, which is close to a 1:2 ratio. There are two affected females among the six affected offspring. Male-to-male transmission has occurred in two generations. These are all clear indications of the autosomal dominant pattern of inheritance. According to the index patient's description and some photographs which were examined, none of his nine siblings is affected and the information concerning his parents is similarly negative. Therefore, it is probable that the disease in the index patient is the expression of a new mutation. His father's and his mother's ages (31 and 23 years, respectively) give no clue to the source of the new mutation. Additional reports document genetic transmission of this syndrome (10,11,35-40). Also, we have seen two additional affected families, including an affected daughter of the patient described by Bruce (41). The family reported here has contributed linkage data which has helped localize the MEN 2B gene to chromosome 10 (42,43).

MTC follow-up

The MTC in this family with MEN 2B has not been as biologically aggressive as we had initially predicted from our earlier experience with sporadic cases. The youngest operated on, IV-5 and possibly IV-4, may have been cured. Despite persistently elevated iCT concentrations in the other affected family members, their MTC has not yet caused harm, as has been true in many families with MEN 2A. Rather, there have been morbid complications of other components of the phenotype, such as the "megacolon" in II-2. Until more long-term follow-up is available from similar families, we think a conservative approach is important in those with persistent hypercalcitoninemia.

References

1. Steiner AL, Goodman AD, Powers SR. Study of a kindred with pheochromocytoma, medullary thyroid carcinoma, hyperparathyroidism and Cushing's disease: Multiple endocrine neoplasia, type 2. *Medicine (Baltimore)* 1968; 47:371-409.
2. Sipple JH. The association of pheochromocytoma with carcinoma of the thyroid gland. *Am J Med* 1961;31:163-6.
3. Manning PC Jr, Molnar GD, Black BM, Prestley JT, Woolner LB. Pheochromocytoma, hyperparathyroidism and thyroid carcinoma occurring coincidentally: Report of a case. *N Engl J Med* 1963;268:68-72.
4. Melvin KE, Tashjian AH Jr, Miller HH. Studies in familial (medullary) thyroid carcinoma. *Recent Prog Horm Res* 1972;28:399-470.
5. Ljungberg O. On medullary carcinoma of the thyroid. *Acta Pathol Microbiol Scand [A]* 1972;231:1-57.
6. Jackson CE, Tashjian AH Jr, Block MA. Detection of medullary thyroid cancer by calcitonin assay in families. *Ann Intern Med* 1973;78:845-52.

7. Keiser HR, Beaven MA, Doppman J, Wells S Jr, Buja LM. Sipple's syndrome: Medullary thyroid carcinoma, pheochromocytoma, and parathyroid disease: Studies in a large family. *Ann Intern Med* 1973;78:561-79.
8. Wagenmann A. Multiple neurome des auges und der zunge. *Ber Dtsch Ophthalmol Ges* 1922;43:282-5.
9. Froboese C. Das aus markhaltigen nervenfaser bestehende, ganglien-zellenlose, echte neurom in rankenform: Zugleich ein beitrag zu den nervosen geschwulsten der zunge und des augenlides. *Virchows Arch [Pathol Anat]* 1922-3;240:312-27.
10. Bartlett RC, Myall RW, Bean LR, Mandelstam P. A neuropolyendocrine syndrome: Mucosal neuromas, pheochromocytoma, and medullary thyroid carcinoma. *Oral Surg Oral Med Oral Pathol* 1971;31:206-20.
11. Khairi MR, Dexter RN, Burzynski NJ, Johnston CC Jr. Mucosal neuroma, pheochromocytoma, and medullary thyroid carcinoma: Multiple endocrine neoplasia type 3. *Medicine (Baltimore)* 1975;54:89-112.
12. Chong GC, Behars OH, Sizemore GW, Woolner LH. Medullary carcinoma of the thyroid gland. *Cancer* 1975;35:695-704.
13. Slavin W. Atomic absorption spectroscopy. New York: Interscience Publishers, 1968.
14. Fiske CH, Subbarow Y. The colorimetric determination of phosphorus. *J Biol Chem* 1925;66:375-400.
15. Kind PRN, King EJ. Estimation of plasma phosphatase by determination of hydrolysed phenol with amino-antipyrine. *J Clin Pathol* 1954;7:322-6.
16. Jiang NS, Stoffer SS, Pikler GM, Wadel O, Sheps SG. Laboratory and clinical observations with a two-column plasma catecholamine assay. *Mayo Clin Proc* 1973;48:47-9.
17. Moyer TP, Jiang N-S, Tyce GM, Sheps SG. Analysis for urinary catecholamines by liquid chromatography with amperometric detection: Methodology and clinical interpretation of results. *Clin Chem* 1979;25:256-63.
18. Pisano JJ. A simple analysis for normetanephrine and metanephrine in urine. *Clin Chim Acta* 1960;5:406-14.
19. Sizemore GW, Go VL, Kaplan EL, Sanzenbacher LJ, Holtermuller KH, Arnaud CD. Relations of calcitonin and gastrin in the Zollinger-Ellison syndrome and medullary carcinoma of the thyroid. *N Engl J Med* 1973;288:641-4.
20. Sizemore GW, Go VL. Stimulation tests for diagnosis of medullary thyroid carcinoma. *Mayo Clin Proc* 1975;50:53-6.
21. Heath H III, Sizemore GW. Plasma calcitonin in normal man: Differences between men and women. *J Clin Invest* 1977;60:1135-40.
22. Heath H III, Sizemore GW. Radioimmunoassay for calcitonin. *Clin Chem* 1982;28:1219-26.
23. Gharib H, Kao PC, Heath H III. Determination of silica-purified plasma calcitonin for the detection and management of medullary thyroid carcinoma: Comparison of two provocative tests. *Mayo Clin Proc* 1987;62:373-8.
24. Arnaud CD, Tsao HS, Littlelike T. Radioimmunoassay of human parathyroid hormone in serum. *J Clin Invest* 1971;50:21-34.
25. Lawrence AM. Glucagon provocative test for pheochromocytoma. *Ann Intern Med* 1967;66:1091-6.
26. Sheps SG, Mayer FT. Histamine and glucagon tests in diagnosis of pheochromocytoma. *JAMA* 1968;205:895-9.
27. Wolfe HJ, Melvin KE, Cervi-Skinner SJ, et al. C-cell hyperplasia preceding medullary thyroid carcinoma. *N Engl J Med* 1973;289:437-41.
28. Carney JA, Sizemore GW, Tyce GM. Bilateral adrenal medullary hyperplasia in multiple endocrine neoplasia, type 2: The precursor of bilateral pheochromocytoma. *Mayo Clin Proc* 1975;50:3-10.
29. Armstrong MD, McMillan A, Shaw KN. 3-methoxy-4-hydroxy-D-mandelic acid, a urinary metabolite of norepinephrine. *Biochim Biophys Acta* 1957;25:422-3.
30. Heath H III, Sizemore GW, Carney JA. Preoperative diagnosis of occult parathyroid hyperplasia by calcium infusion in patients with multiple endocrine neoplasia, type 2a. *J Clin Endocrinol Metab* 1976;43:428-35.
31. Roth SI. Recent advances in parathyroid gland pathology. *Am J Med* 1971;50:612-22.
32. Capen CC, Roth SI. Ultrastructural and functional relationships of normal and pathologic parathyroid cells. *Pathobiol Annu* 1973;3:129-75.
33. Nakagami K, Yamazaki Y, Tsunoda Y. An electron microscopic study of the human fetal parathyroid gland. *Z Zellforsch Mikrosk Anat* 1968;85:89-95.
34. Williams ED, Pollock DJ. Multiple mucosal neuromata with endocrine tumours: A syndrome allied to von Recklinghausen's disease. *J Pathol Bacteriol*

1966;91:71-80.

35. Jones BA, Sisson JC. Early diagnosis and thyroidectomy in multiple endocrine neoplasia, type 2b. *J Pediatr* 1983;102:219-23.

36. Nankin H, Hydovitz J, Sapira J. Normal chromosomes in mucosal neuroma variant of medullary thyroid carcinoma syndrome. *J Med Genet* 1970;7:374-8.

37. Gorlin RJ, Sedano HO, Vickers RA, Cervenka J. Multiple mucosal neuromas, pheochromocytoma and medullary carcinoma of the thyroid—A syndrome. *Cancer* 1968;22:293-9.

38. Gorlin RJ, Vickers RA. Multiple mucosal neuromas, pheochromocytoma, medullary carcinoma of the thyroid and marfanoid body build with muscle wasting: Reexamination of a syndrome of neural crest malmigration. *Birth Defects* 1971;7:69-72.

39. Schimke RN. Familial tumor endocrinopathies. *Birth Defects* 1971;7:55-65.

40. Woolner LB, Beahrs OH, Black BM, et al. Thyroid carcinoma: General considerations and follow-up data in 1,181 cases. In: Young S, Inman DR, eds. *Thyroid neoplasia*. London, UK: Academic Press, 1968:51-77.

41. Bruce KW. Solitary neurofibroma (neurilemmoma, schwannoma) of the oral cavity. *Oral Surg* 1954;7:1150-9.

42. Jackson CE, Conneally PM, Sizemore GW, Tashjian AH Jr. Possible linear order of genes for endocrine neoplasia type 2, the P red cell antigen and HL-A on chromosome 6. *Birth Defects* 1976;12:159-64.

43. Jackson CE, Norum RA. The genetics of the multiple endocrine neoplasia type 2B. *Henry Ford Hosp Med J* 1992;40:232-5.