

## Application of Large Prestress Strands in Precast/Prestressed Concrete Bridges

Amin K. Akhnoukh <sup>a\*</sup>

<sup>a</sup> Associate Professor, East Carolina University, 343B Rawl Building, Greenville, NC, 27858, USA.

Received 06 October 2019; Accepted 16 December 2019

### Abstract

The objective of this research is to investigate the advantage of using large-diameter 0.7-inch (18 mm) strands in pretention applications. Large-diameter strands are advantageous in bridge construction due to the increased girders capacity required to sustain exponential increase in vehicle numbers, sizes, and weights. In this research, flexure capacity of girders fabricated using 0.7-inch (18 mm) diameter strands will be calculated and compared to bridge capacities constructed using smaller strands. Finally, two similar bridge sections will be designed using 0.6-inch (15 mm) and 0.7-inch (18 mm) diameter strands to quantify the structural advantages of increased strand diameter. The research findings showed that a smaller number of girders is required for bridge construction when larger strands are used. Four girders are required to design the bridge panel using high performance concrete and large diameter strands, as compared to 6 girders required when regular concrete mix designs and normal size strands are used. The advantages of large strands and high-performance concrete mixes include expedited construction, reduced project dead loads, and reduced demand for labor and equipment. Thus, large strands can partially contribute to the improvement of bridge conditions, minimize construction cost, and increase construction site safety.

*Keywords:* Large Prestress Strands; 0.7-inch Strands; Pretention Applications; I-girders; Strands Spacing; High Strength Concrete.

### 1. Introduction

The percentage of structurally deficient bridges within the United States National Bridge Inventory (NBI) is more than 10%, excluding railroad bridges, according to recent statistics. Structurally deficient bridges include all bridges with severe deterioration in one or more of the bridge structural components (i.e. bridge substructure, girders, and/or deck). Bridge deterioration is enough to reduce the load rating of bridge structural component. Majority of structurally deficient bridges result from increased traffic, the exponential increase of vehicle loading, environmental attacks (i.e. scour, freeze and thaw cycles, etc.), and the use of de-icing salts and chemicals in northern states. The Federal Highway Administration (FHWA) and State Departments of Transportation (DOTs) have recently launched multiple research programs to investigate the possibility of constructing bridges with longer life spans and/or using new generations of construction materials with superior characteristics to minimize maintenance, repair, and replacement activities for different bridge structural elements. New generations of construction materials include reactive powder concrete [1-4], commercially known as ultra-high-performance concrete, fiber reinforced polymers, and large diameter strands.

The main objective of this research project is to investigate the possible use of large-diameter prestressing strands in fabricating bridge I-girders with superior strength and quantify the structural advantages attained when large diameter strands are used in I-girder fabrication. The research project includes two phases: First, an analytical phase to calculate

\* Corresponding author: [akhnoukha17@ecu.edu](mailto:akhnoukha17@ecu.edu)

 <http://dx.doi.org/10.28991/cej-2020-03091458>



© 2019 by the authors. Licensee C.E.J, Tehran, Iran. This article is an open access article distributed under the terms and conditions of the Creative Commons Attribution (CC-BY) license (<http://creativecommons.org/licenses/by/4.0/>).

the structural advantages of using large-diameter strands in fabricating precast/prestressed concrete I-girders, as compared to current practices. Second, an experimental phase to explore the possibility of using large diameter strands without violating the AASHTO LRFD specifications for estimating strands transfer length, development length, and end zone reinforcement [5]. In this paper, the advantages of high-performance concrete and large diameter prestress strands are listed. Precast/prestressed I-girders are fabricated using larger strands, and the girder performance is tested through a full-scale destructive testing. Finally, a case study is presented, where a bridge section is designed using conventional concrete mixes and regular strands diameters and compared to similar bridge section designed using high performance concrete and large diameter strands to compare the performance of the two sections.

## 2. Literature Review

Seven-wire prestress strands are commonly used in the United States in different types of construction projects, including heavy construction. Strands of 0.5-inch (13 mm) diameter were widely used in the industry until early 1990s. Minimum strands centerline spacing was four times the strand diameter. Thus, I-girders were fabricated using strands placed at a centerline spacing of 2.0 inch. (50 mm) In 1996, the Federal Highway Administration (FHWA) released a memorandum allowing the use of 0.6-inch (15 mm) strands at 2.0-inch (50 mm) spacing and reduced the minimum centerline spacing of 0.5-inch (13 mm) strands to 1.75 inch [6]. According to the FHWA memorandum, 0.6-inch (15 mm) diameter strands are safe to use at a centerline spacing less than four times the strand diameter without violating the existing code transfer and development length equations. Currently, several research programs within the United States are investigating the possibility of using seven-wire strands of 0.7-inch (18 mm) diameter in precast/prestressed concrete industry. Large 0.7-inch (18 mm) strands have been used for decades in cable-stayed bridges and mining applications in the United States, and as post-tensioned tendons in Europe and Japan. Due to its limited applications, 0.7-inch (18 mm) strands are produced by limited manufacturers. Large 0.7-inch (18 mm) strands have a cross-section area of 0.296 in<sup>2</sup> (1.9 cm<sup>2</sup>) compared to 0.217 in<sup>2</sup> (1.4 cm<sup>2</sup>) for 0.6-inch (15 mm) strands, and 0.153 in<sup>2</sup> (0.9 cm<sup>2</sup>) for 0.5-inch (13 mm) strands. Large diameter 0.7-inch (18 mm) strands are shipped to precast yards in spools [7], as shown in Figure 1. Strand properties include minimum strand yield strength of 1% elongation ( $f_y = 71,500$  lbs. (32432 kgm)) and minimum breaking strength is 79,400 lbs (36015 kgm). according to ASTM specifications [8].



Figure 1. Spools of 0.7 in. strands [7]

Large 0.7-inch diameter strands were introduced for the first time for pretensioned applications in North America in the construction of the Pacific Street and Interstate 680 highway bridge in Omaha, Nebraska, as shown in Figure 2. The bridge girders were fabricated using 0.7-inch (18 mm) strands placed at a center-line spacing in excess of 2.0 inch (50 mm). Strand spacing greater than 2.0 inch (50 mm) was requested by the bridge department at the Nebraska Department of Roads to avoid potential structural problems associated with minimal spacing including possible increase in strand transfer and development length. Larger strand spacing was supported by pre-casters to avoid potential fabrication problems due to the increased prestressing force applied. Additional prestressing force, which is linearly proportional to strand cross section, may result in multiple construction problems including: 1) failure of prestressing beds, which was designed for use with smaller strands, 2) insufficient statistical data regarding strands mechanical properties as yielding and ultimate strength, 3) safety hazard associated with strand draping (harping) due to the insufficient pull-down devices capacity, 4) excessive cracking at girder end zone due to the higher forces applied to the girder ends upon strand release, 5) larger camber, which may result in excessive tensile cracks at girder's top fiber.



Figure 2. Pacific Street and interstate 680 highway bridge in Omaha, Nebraska

The analysis of I-girders fabricated using 0.7-inch (18 mm) strands at 2.0-inch (50 mm) centerline spacings was investigated in a recent research study. The study concluded that additional steel reinforcement is recommended towards the beam ends (end zone reinforcement) to avoid splitting or excessive cracking at the interfacing surface between bottom flange and web. The study highlighted the structural advantages and the substantial increase in girders capacity when 0.7-inch (18 mm) strands are used at 2.0 inch (50 mm) spacing in girder fabrication [9, 10]. A different research investigated the durability of high strength girders fabricated using larger strands. The study found that a typical concrete mix designs used in fabricating these girders include relatively high content of supplementary cementitious materials (SCMs). SCMs high content is required to attain high compressive strength. In addition, SCMs result in a substantial decrease in deleterious alkali-silica and alkali-carbonate reactions [11]. In a relevant study, high performance concrete mixes are developed using economic pozzolanic materials to use in precast/bridge industry which could result in a positive impact on environment [12].

Mix designs included a high percentage of binder and limited water-to-powder ratio. Similarly, high performance concrete mixes were used in fabricating bridge I-girders using welded wire reinforcement (WWR) for increasing girders shear capacity. The fabricated girders displayed a substantial increase in load bearing capacity. The girder capacity was comparable to girders fabricated using proprietary UHPC girders and tested at the FHWA research facility in Virginia [13]. In a different research project, the use of micro and nano materials including micro-silica and multi-wall carbon nano-tubes showed the possibility of pouring structural elements with superior characteristics and substantial increase in load-bearing capacity [14].

Higher grade large-diameter prestressing strands were investigated in a different research project. The outcomes of the research investigation showed that sufficient confinement and high concrete capacity are required for successfully utilizing larger strands in precast/prestressed bridge girders fabrication [15, 16]. Currently, multiple research projects are investigating the reliability of girder designs using different concrete grades [17]. Further investigation is required to identify the reliability index for shear and flexure capacities of girders fabricated using larger diameter strand.

### 3. Structural Advantages of 0.7 In. Strands

The prestressing force applied during girders fabrication is linearly proportional to the total cross section area of strands. The area of a single 0.7-inch (18 mm) strand (0.294 in<sup>2</sup>) is 35% greater than the area of 0.6-inch (15 mm) strand (0.217 in<sup>2</sup>) and 92% greater than the area of 0.5-inch (13 mm) strand (0.153 in<sup>2</sup>). The increase in the strand cross section area is associated with an equal increase in pretension force applied to the girder. Thus, the girder flexure capacity is increased if 0.5-inch (13 mm) or 0.6-inch (15 mm) strands are replaced with similar number of 0.7-inch (18 mm) strands. Similarly, the girder flexure capacity is maintained by replacing 0.5-inch (13 mm) and 0.6-inch (15 mm) strands with fewer number of 0.7-inch (18 mm) strands. The increase of prestressing force due to the use of 0.7-inch strands at different centerline spacing compared to the current practice of using 0.6-inch (15 mm) strands at 2.0-inch (50 mm) spacing is shown in Table 1.

Table 1. Prestressing force increase due to 0.7-inch strand compared to 0.6-inch (15 mm) strands

| Vertical Spacing (in.) | Horizontal Spacing (in.) |                  |                  |                   |
|------------------------|--------------------------|------------------|------------------|-------------------|
|                        | 2 inch (50 mm)           | 2.1 inch (53 mm) | 2.2 inch (56 mm) | 2.25 inch (57 mm) |
| 2 inch (50 mm)         | 35.5%                    | 29.0%            | 23.2%            | 20.4%             |
| 2.1 inch (53 mm)       | 29.0%                    | 22.9%            | 17.3%            | 14.7%             |
| 2.2 inch (56 mm)       | 23.2%                    | 17.3%            | 12.0%            | 9.5%              |
| 2.25 inch (57 mm)      | 20.4%                    | 14.7%            | 9.5%             | 7.0%              |

Due to the limited area of the bottom flange of different types of I-girders (AASHTO girders, NU I-girders, etc.), it is required to maintain a minimal strand centerline spacing to maximize the number of strands used in girder fabrication. In this research, NU I-girders are used in analytical and experimental investigation of 0.7-inch strands structural advantages. NU I-girders are standard I-girders developed at the University of Nebraska-Lincoln and are widely used in several states and Canada. NU I-girders are characterized by their standard wide bottom flange, which accommodate a maximum number of 60 strands placed at a centerline spacing of 2.0 inch (50 mm). NU I-girders are currently produced in different standard depths ranging from 35.4 inch (90 cm) to 78.8 inch (200 cm). An example of a standard NU I-girder dimensions and bottom flange strands placement are shown in Figure 3. Structural advantages of using large diameter strands are attained when girders are poured using high strength concrete (HSC), and a minimum concrete compressive strength ( $f_c'$ ) of 5000 psi (35 MPa) is used in pouring cast-in-place bridge decks. Increased flexure capacity of NU I-girder and the effect of girder and deck strength on structural advantages of 0.7-inch (18 mm) strands are discussed in the following sections.

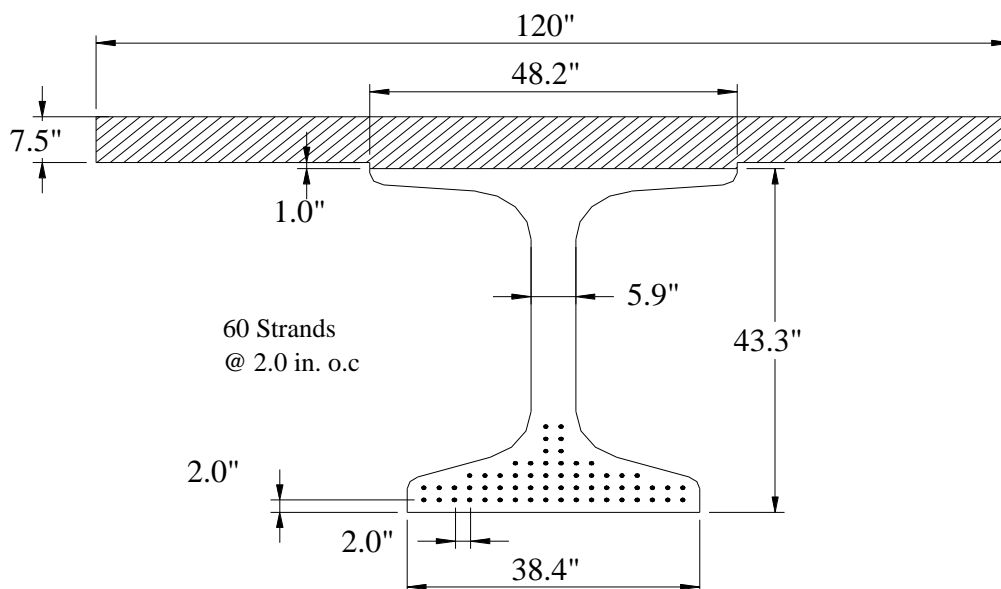

**Figure 3. Typical NU I-girder with maximum number of strands in bottom flange (60 strands)**

The ultimate flexure capacity of a typical NU I-girder composite section was calculated using different girder concrete compressive strength and different strand diameters. The NU I-girder had a total depth of 43.3 inch (110 cm). A 1.0-inch (25 mm) deep haunch was poured on the girder, followed by a deck of 7.5-inch (19 cm) structural depth and 120-inch (305 cm) width. A maximum number of 60 strands were used in bottom flange fabrication. Strands of different diameters (0.5, 0.6, and 0.7 inch) were used at a centerline spacing of 2.0 inch (50 mm), and concrete of compressive strength ranging from 6,000 psi (42 MPa) to 12,000 psi (84 MPa) were used in girder fabrication. Details of NU I-girder composite section is shown in Figure 3.

The ultimate flexural capacity of the girder was calculated using AASHTO LRFD Strength I equation. The flexure capacity of the I-girder using 0.7-inch strands substantially increased when high strength concrete was used in girder fabrication versus no flexural capacity improvement attained when 0.5-inch (13 mm) and 0.6-inch (15 mm) strands were used. The girder compressive strength had no effect on girder flexure capacity when 60-0.5-inch (13 mm) and 0.6-inch (15 mm) strands are used as the compression block (Whitney stress block) depth was smaller than the deck structural thickness. The increase in prestressing force associated with large diameter strands resulted in a higher compression block depth. The increased depth resulted in a partial existence of the compression block within the girder. Hence, the increase in girder concrete compressive strength resulted in increased girder-deck composite section flexural capacity. Composite section capacity calculation when 60 strands of different diameters were used at different girder concrete compressive strength is shown in Figure 4.

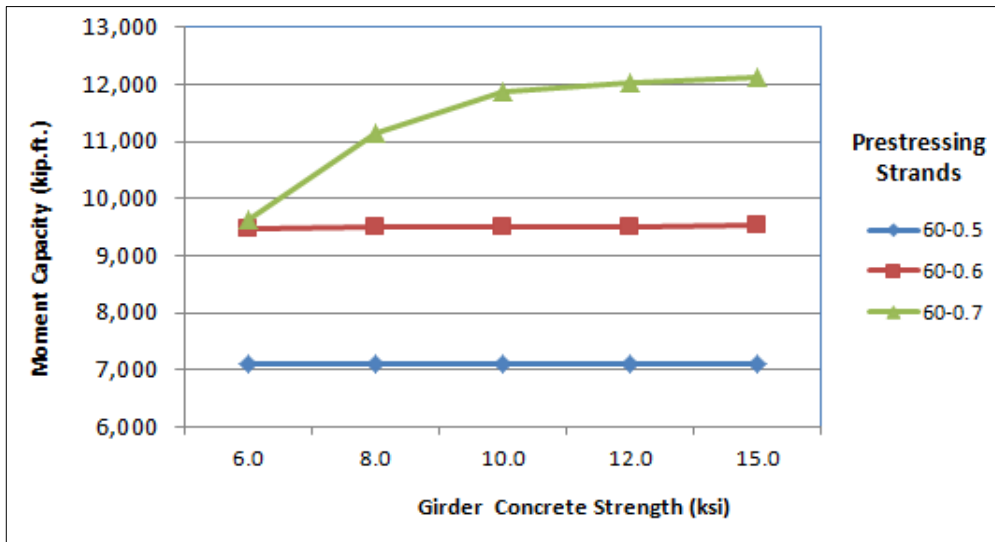

Figure 4. Composite section capacity for different strand diameters at different girder strength

Similarly, the value of strands tensile stress at section ultimate capacity is proportional to slab and girder concrete compressive strength. Higher concrete strength results in higher strand tensile stress (tension failure), which is required for optimized girder design. According to current strand mechanical properties, tensile stress greater than 243 ksi (1700 MPa) (strands yield strength) is highly recommended for design optimization. Effect of girder compressive strength on Strands tensile stress at a deck concrete capacity of 4,000 psi (28 MPa) is shown in Figure 5.

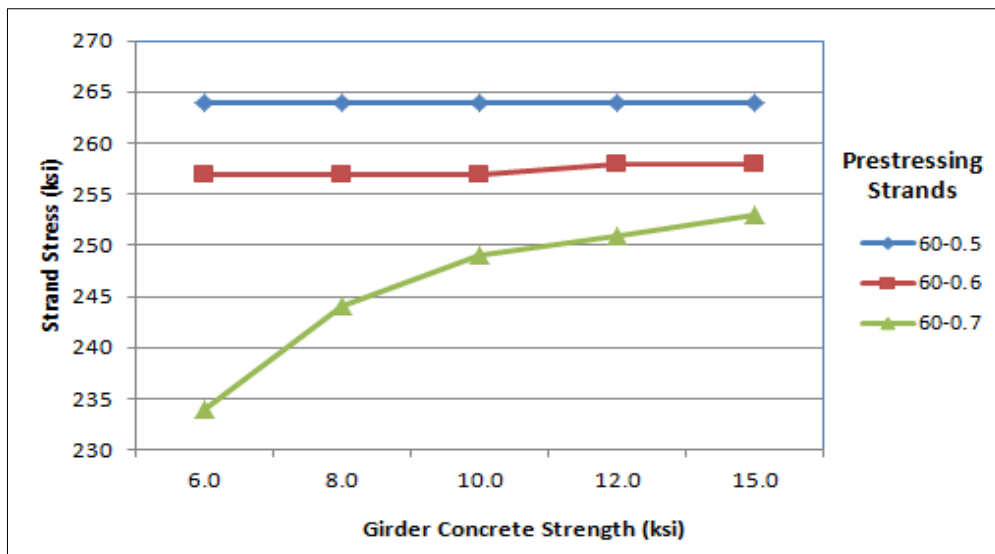

Figure 5. Strands tensile stress at section ultimate capacity (deck strength = 4,000 psi (28 MPa))

### 3.1. NU-I Girder Capacity for 0.7-inch Strands at Different Deck Concrete Strength

The depth of the compressive block is dependent on deck width and concrete compressive strength. Increased deck strength results in a compression block with reduced depth, and increased moment arm value. Thus, ultimate section capacity is increased when deck concrete strength is increased. The ultimate capacity of composite section shown in Figure 3 is calculated when 60-0.7-inch diameter strands are used at different deck capacities of 4,000, 5,000, and 6,000 psi (28, 35 and 42 MPa) respectively. Composite section ultimate flexure capacity was calculated as shown in Figure 6. Based on calculated strength values, the following conclusions were made: 1) increased deck compressive strength results in a significant increase in composite section flexure capacity when large number of 0.7 (18 mm) strands is used, 2) for smaller values of deck strength; the rate of increase in composite section capacity is highly dependent on girder strength, and 3) a minimum compressive strength of 5,000 psi (35 MPa) is required for the deck strength to minimize the effect of girder strength on composite section capacity.

Based on the structural advantages attained when 0.7-inch (18 MPa) prestressing strands, experimental investigation was conducted to explore the possibility of using 0.7-inch (18 MPa) strands at centerline spacing of 2.0 inch (50 mm) to fabricate I-girders. The experimental investigation focused on: 1) the impact of larger pretension force associated

with 0.7-inch (18 MPa) strands on the end zone cracks developed upon strand release, 2) the possibility of using current AASHTO equations in calculating strands transfer and development length. Results of a previous research regarding the fabrication of girders using 0.7-inch (18 MPa) strands at a centerline spacing of 2.2 inch (56 mm) were used to fabricate and test a NU I-girder at a centerline spacing of 2.0 inch (50 mm). Girders fabrication, test setup, experimental investigations, and test results are described in the following section.

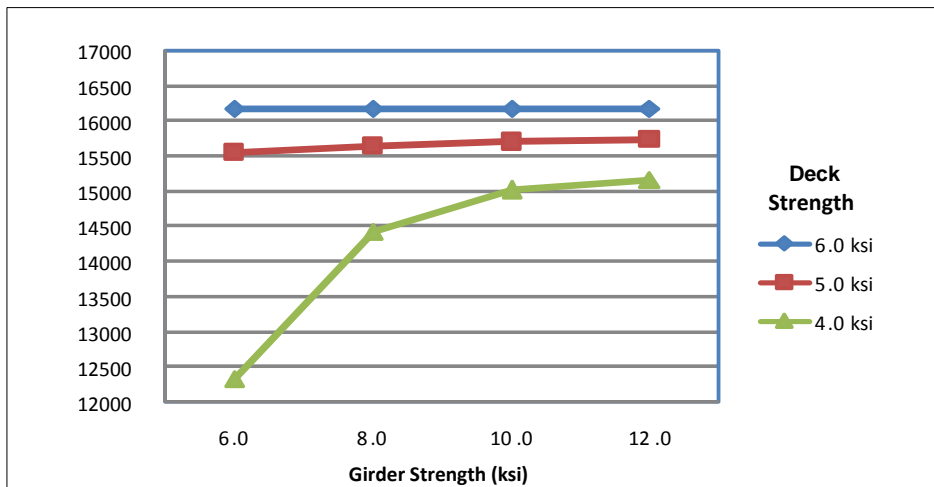

Figure 6. Ultimate composite section capacity for different deck strength (60-0.7 strands)

### 4. Experimental Investigation

Two full-scale girders were tested in the University of Nebraska-Lincoln using 0.7-inch (18 mm) prestressing strands. The results of the two girders were used to investigate the possibility of using large strand diameters in girder fabrication without violating the AASHTO LRFD specifications. First girder, denoted as girder (A), was fabricated using 0.7-inch (18 mm) strands placed at a centerline spacing greater than 2.0 inch (50 mm) to minimize the end zone cracking and reduce possible fabrication problems resulting from the increased prestressing force and lack of prestressing bed capacities. Based on successful fabrication and test results of girder (A), a second girder, denoted as girder (B), was fabricated using 0.7-inch (18 mm) strands placed at centerline spacing of 2.0 inch (50 mm). Detailed fabrication and test results of the two girders are shown in the following sections:

#### 4.1. Girder A Fabrication

NU900 girder was designed and tested to investigate the potential of using 0.7-inch (18 mm) strands in fabricating I-girders. Due to the lack of technical knowledge, fabrication experience, and bed capacities, 0.7-inch (18 mm) strands were not used at the standard 2.0-inch (50 mm) centerline spacing to reduce the prestressing force upon strands release. Girder (A) contained 24 0.7-inch (18 mm) strands in the bottom flange as tension reinforcement and 4-0.5 inch (13 mm) partially stressed stands in the top flange. The girder transverse reinforcement included the following:

- 4 #6 bars for end zone reinforcement
- 2 #4 bars at 3-inch spacing for shear reinforcement
- 15 #3 hairpins for strand confinement at the bottom flange within the first 45 inch of the girder ends. Cross-section of the girder is shown in Figure 7.

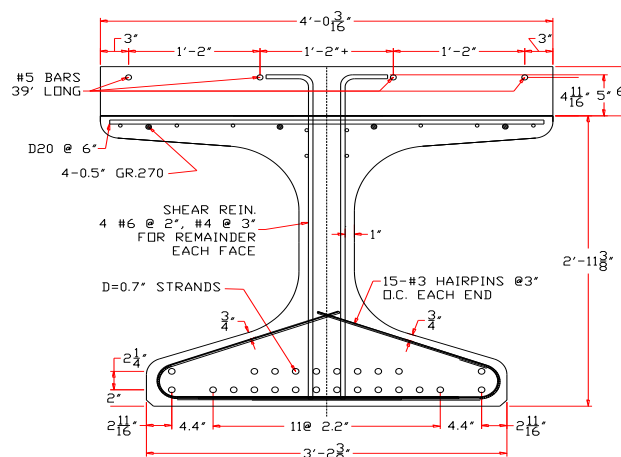
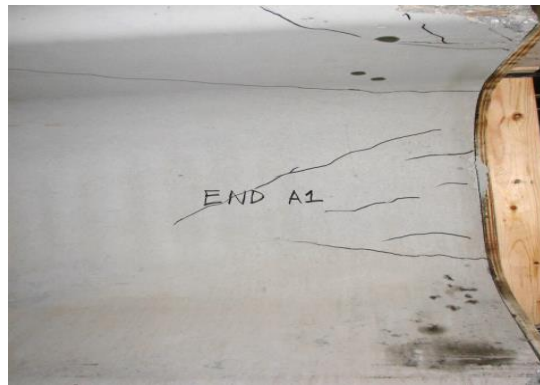

Figure 7. NU900 girder (Pacific Street Project, Omaha, NE) [3]

Girder (A) design and fabrication processes included multiple problems including: 1) lack of prestressing bed capacities in most prestressing yards, 2) absence of pull-down devices with sufficient capacity to fabricate girders with draped strands, and 3) possible development of excessive end zone cracking upon strand release. Due to the aforementioned problems, 0.7-inch (18 mm) strands were used at a horizontal spacing of 2.2 inch (56 mm) and a vertical spacing of 2.25 inch (57 mm) Larger strand centerline spacing resulted in a reduced number of strands, which reduced the potential problems due to lack of bed capacity. Straight strands were used in girder fabrication to avoid possible safety problems due to possible failure of pull-down devices. Finally, sufficient bottom flange confinement was used towards the end of the girder to reduce the end zone cracking upon strands release.

**4.2. Girder Test Setup and Results**

The girder experienced minimal end zone cracking upon strand release. Cracks were scattered along the height of the girder section, as shown in Figure 8.



**Figure 8. End zone cracking upon strand release at girder ends [3]**

A reinforced concrete deck of 6.0-inch (15 cm) depth was poured over the deck top flange prior to girder testing. The girder was instrumented by a series of 19 detached mechanical discs (Demec points) on each side of its two ends to measure the strands transfer length. The transfer length was determined by measuring the distance from the end of the girder to the point where 95% of the maximum strain was measured [18]. The Demec discs reading, shown in Figure 9, displayed that strain stabilized at 35-inch (89 cm) distance from the girder end. This distance, considered as the transfer length of the 0.7-inch (18 mm) strands, is less than the transfer length estimated for strands by the AASHTO LRFD specifications, which is calculated as:

$$\text{Transfer length} = l_t = 60 * d_b = 60 * 0.7 = 42" (107 \text{ cm})$$

Finally, the girder was tested by applying a concentrated load at distance of 15 ft. from the girder end and 14 ft. (427 cm) from the support centerline. According to the AASHTO LRFD equation, the development length is calculated as follows:

$$\text{Development length} = 1.6 \left( 270 - \frac{2}{3} 160 \right) 0.7 = 182.9 \text{ in.} = 15.2 \text{ ft} (463 \text{ cm}).$$

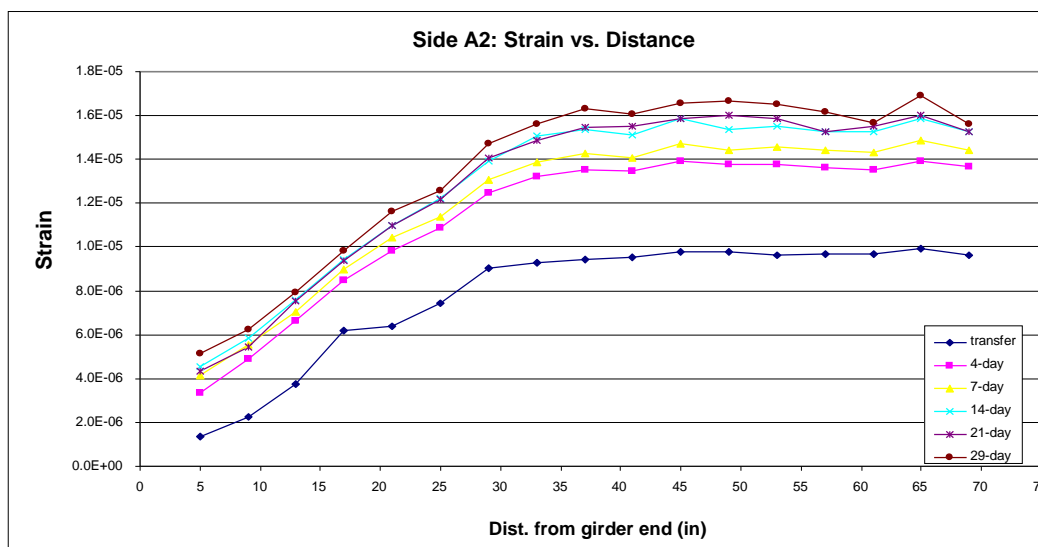

**Figure 9. Demec point reading for transfer length measurement [5]**

The girder ultimate flexure capacity at development length was calculated as 5,157 k-ft. The ultimate capacity is equivalent to a point load of 582 kip (264 ton). at distance of 15 ft (457 cm). from the girder’s end, which is equivalent to the calculated development length. The load test setup of the girder is shown in Figure 10. The load versus deflection for the tested girder was recorded. The load versus deflection chart displayed that the beam elastic behavior ended at a load of 400 kips (181.4 ton) while the ultimate load reached prior to failure was 600 kips (272.2 ton).



Figure 10. Load testing of NU900 girder

The ultimate girder capacity for flexure, shown in Figure 11 at distance of 15 ft. (457 cm) showed that the development length for the 0.7-inch (18 mm) strands can be conservatively calculated according to the current AASHTO LRFD equation.

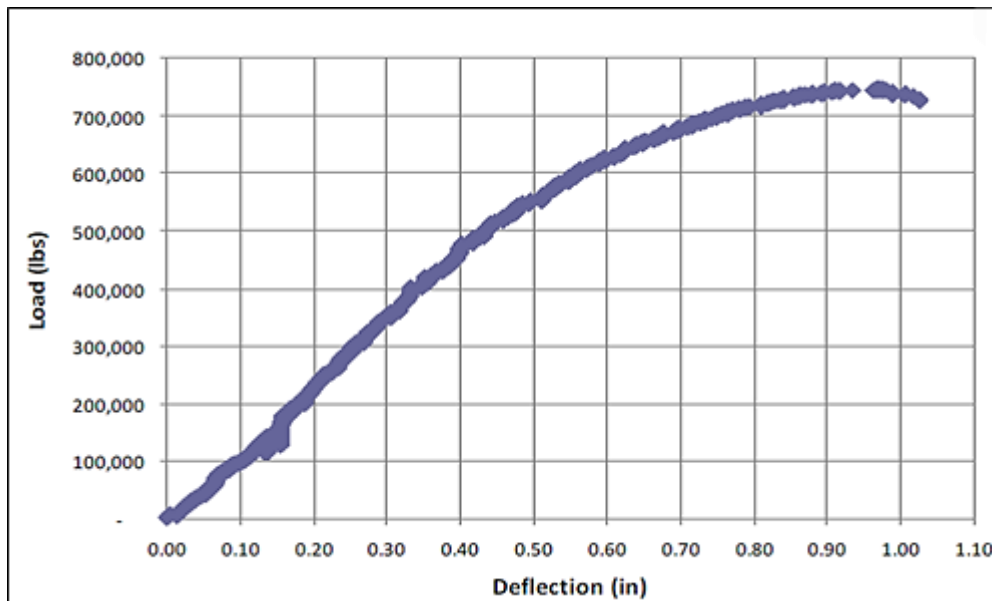

Figure 11. Girder (A) load versus deflection relation

### 4.3. Girder (B) Fabrication

Based on the successful fabrication and testing of girder (A) fabricated with 0.7-inch (18 mm) strands at a centerline spacing of 2.2 and 2.25 inches (56 and 57 cm) the research team decided to fabricate a similar I-girder using 0.7-inch (18 mm) strands at 2.0-inch (50 mm) centerline spacing. The fabricated girder, denoted as girder (B), represents the first precast/prestressed girder fabricated using 0.7-inch (18 mm) strands at a centerline spacing of 2.0 inch (50 mm) in North



America. Girder (B) was an NU900 with a 1-inch haunch and a 7.5-inch deck (19 cm). The girder bottom flange contained 30-0.7 inch (18 mm) straight prestressing strands. Welded wire reinforcement (WWR) was used for girder shear reinforcement, and the girder end zone reinforcement contained 4#6 bars at 2.0 inch (50 mm) spacing. Details of girder cross section and reinforcement are shown in Figure 12.

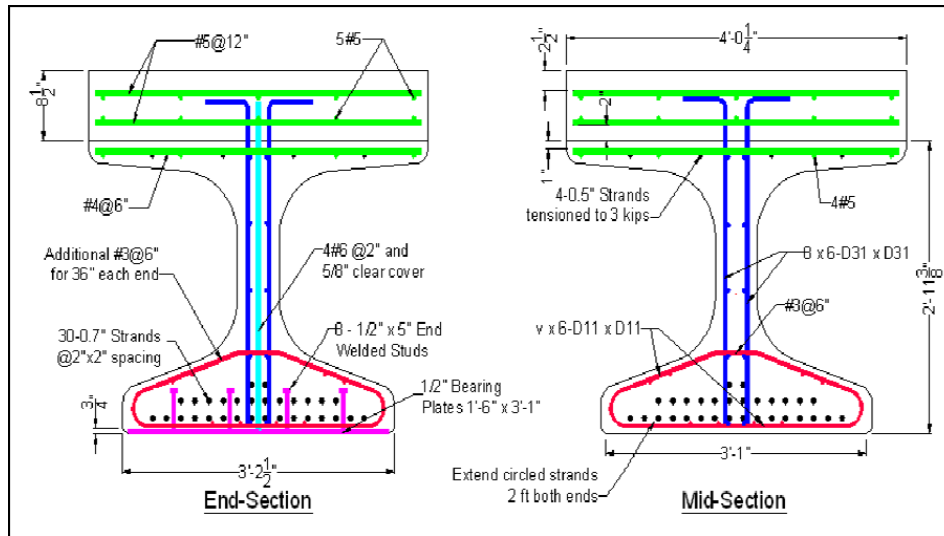

Figure 12. Girder (B) cross section and reinforcement details

4.4. Girder Test Setup and Results

The development length for girder (B) was calculated using AASHTO LRFD equation as follows:

$$L_d = 1.6 \times \left( f_{ps} - \frac{2}{3} f_{pe} \right) \cdot d_b = 1.6 \times \left( 270 - \frac{2}{3} \times 160 \right) \cdot 0.7 = 183 \text{ inch (465 cm)}$$

Based on development length calculation, the girder was tested to its ultimate capacity with a point load acting on 15 ft (457 cm) from its end, as shown in Figure 13. The load point of action existed at a distance from the girder end equal to the development length, and no slippage was noticed on the strands until the load reached to 800 kips (362 ton). It was decided to stop the load application once a total load of 800 kips (362 ton) is applied and sustained, as the ultimate flexure capacity is already attained at this level of loading.

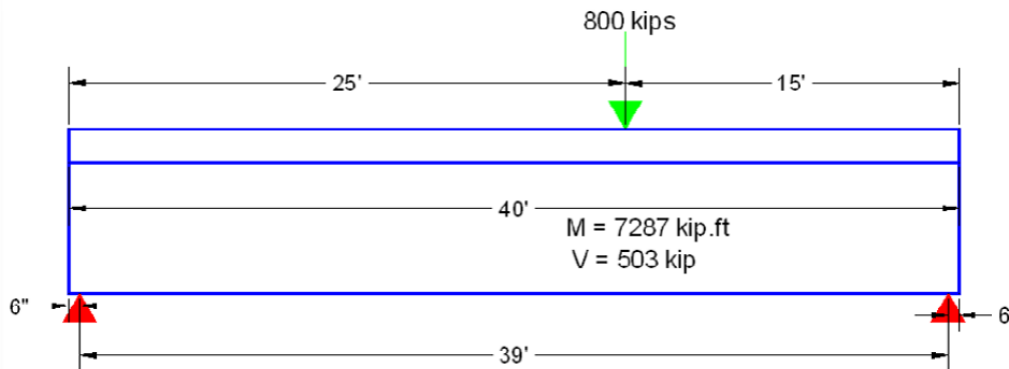

Figure 13. Girder (B) test setup

5. Case Study

The successful fabrication and test results of precast/prestressed concrete I-girders using 0.7-inch (18 mm) strands placed at 2.0-inch (50 mm) centerline spacing will allow for the wide spread of large strands in construction industry, especially for heavy construction projects where considerable material, labor, and time savings may be achieved. In order to calculate the afore-mentioned savings, a two-span bridge was designed using 15,000 psi (105 MPa) concrete and 0.7-inch (18 mm) strands for girder fabrication. The designed bridge was 46 ft 8-inch (14.22 m) wide, and girder span was 105 ft. (32 m). The designed bridge has the following parameters:

- Girders are continuous for live load;
- Standard NU I-girders were used, with 35.4-inch (90 cm) depth;
- Bottom flange was reinforced by 60 0.7-inch (18 mm) strands at centerline spacing of 2.0 in (50 mm);

- Deck structural thickness of 7.5 (19 cm) inch was used. Total deck thickness = 8.0 inch (20 cm);
- A 1.0-inch (25 mm) thick haunch was poured on top of girders to account for camber;
- Haunch and deck compressive strength were 5,000 psi (35 MPa);
- Four girders were used at a centerline spacing of 12 ft. (366 cm).

The afore-mentioned bridge specifications were successfully used to design a 105 ft. (32 m) span bridge. For comparison purposes, a similar bridge was designed using 8 ksi (56 MPa) concrete and 0.6- inch (15 mm) diameter strands. The equivalent design required the use of 6 girders spaced at 8 ft. (2.44 m) spacing. Material quantities and production prices price of the two design alternatives are shown in Table 2. The pricing of bridges included \$850 per cubic yard for 8 ksi (56 MPa) concrete girders, \$950 per cubic yard for high strength concrete girders (15 ksi (105 MPa)), \$450 per cubic yard for cast-in-place haunch and slab, \$0.85 per pound for prestressing strands, and \$0.75 per pound for reinforcing steel

By comparing the production cost of both design alternatives for the bridge superstructure, a direct saving of 14% is achieved when bridge girders are fabricated using high strength concrete and 0.7-inch (18 mm) prestressing strands compared to the current practices, where 8 ksi (56 MPa) concrete and 0.6-inch (15 mm) diameter strands are used.

**Table 2. HSC girder cost analysis vs. regular concrete girders**

|                          | Girder Concrete (yd <sup>3</sup> ) | Slab Concrete (yd <sup>3</sup> ) | Huanch Concrete (yd <sup>3</sup> ) | Strands weight (lbs) | Slab steel (lbs) |
|--------------------------|------------------------------------|----------------------------------|------------------------------------|----------------------|------------------|
| 0.7 in. + 15 ksi Girders | 142                                | 245                              | 10.6                               | 51,000               | 68,000           |
| Cost (USD)               | 135,000                            | 110,000                          | 5,000                              | 43,350               | 51,000           |
| Total Cost (USD)         | 344,350                            |                                  |                                    |                      |                  |
| 0.6 in. + 8 ksi Girders  | 213                                | 245                              | 15.9                               | 56,000               | 68,000           |
| Cost (USD)               | 181,000                            | 110,000                          | 7,000                              | 47,600               | 51,000           |
| Total Cost (USD)         | 396,600                            |                                  |                                    |                      |                  |

The use of larger strands and higher strength concrete requires a fewer girders to be used, as shown in Figure 14. This reduction in girder number results in expedited construction and minimizes labor crews; and reduces the capacity and working hours of heavy construction equipment

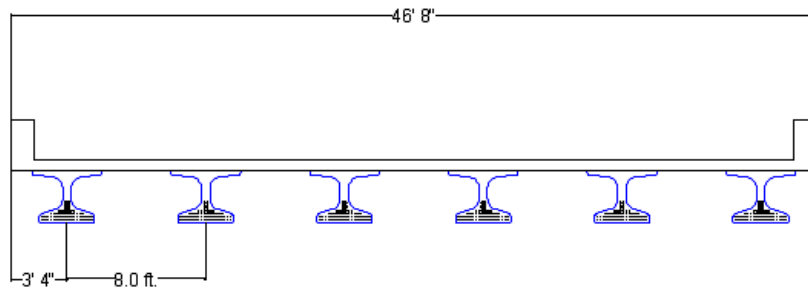

8 ksi and 0.6 in. strands bridge section

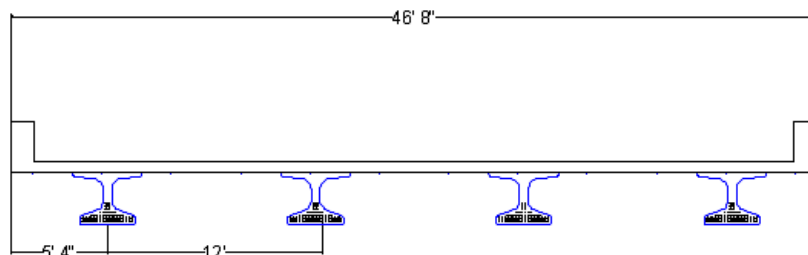

HSC and 0.7 in. strands bridge section

**Figure 14. Superstructure Savings using Large strands**

## 6. Conclusion

Large prestressing strands of 0.7-inch (18 mm) diameters were successfully used in fabricating NU I-girders at 2.0-inch (50 mm) centerline spacing. Transfer and development lengths of 0.7-inch (18 mm) strands used at 2.0-inch (50 mm) centerline spacing were conservatively estimated by AASHTO LRFD specifications equations. The use of end zone reinforcement at bottom flange confinement minimized the end zone cracking developed upon strand release. The structural advantages of 0.7-inch (18 mm) strands are maximized when high strength concrete ( $f_c' \geq 12,000$  psi (84 MPa)) are used in girder fabrication and a minimum concrete compressive strength of 5,000 psi (35 MPa) are used to pour cast-in-place bridge decks. Based on the analytical study, I-girder flexure capacity increase of 35.5% and 92% can be attained when similar number of 0.7-inch (18 mm) strands are used as compared to 0.5-inch (13 mm) and 0.6-inch (15 mm) diameter strands respectively. The structural advantages of 0.7-inch (18 mm) strands allow the bridge designer to use similar number of strands to achieve an increased girder capacity, which results in shallower girder sections and a higher girder span-to-depth ratio. Similarly, bridge designers are allowed to use fewer strands to achieve a given capacity. The used of fewer strands results in material savings, labor savings, and expedited construction due to fewer strand pretension and release operations during girder fabrication, and the possible reduction in the total number of girders required for a given bridge construction project.

Future research is required to 1) investigate the possibility of increasing the prestressing bed capacities to enable the use of large number of 0.7 inch strands, 2) increase the capacity of pull-down devices to produce structural members using draped (harped) strands, and 3) provide sufficient statistical data required for reliability analysis of I-girders produced using high strength concrete and 0.7 inch (18 mm) diameter prestressing strands.

## 7. Funding and Acknowledgements

The author would like to acknowledge the Nebraska Department of Roads (NDOR) for funding the research experimental investigation. The author would like to acknowledge the generous material donors, including Insteel and Ivy Steel for strand supplies and Chryso Chemicals for HRWR donation. Finally, the author would like to acknowledge Drs. Maher Tadros and George Morcoucous for their scientific advice.

## 8. Conflicts of Interest

The authors declare no conflict of interest.

## 9. References

- [1] Akhnoukh, Amin K., and Hala Elia. "Developing High Performance Concrete for Precast/prestressed Concrete Industry." *Case Studies in Construction Materials* 11 (December 2019): e00290. doi:10.1016/j.cscm.2019.e00290.
- [2] Kleymann, Matt J., Amgad M. Girgis, and Maher K. Tadros. "Developing User Friendly and Cost Effective Ultra-High Performance Concrete." In *HPC: Build Fast, Build to Last. The 2006 Concrete Bridge Conference* Portland Cement Association Federal Highway Administration Nevada Department of Transportation American Concrete Institute (ACI). 2006.
- [3] Soliman, Nancy A., and Arezki Tagnit-Hamou. "Using Glass Sand as an Alternative for Quartz Sand in UHPC." *Construction and Building Materials* 145 (August 2017): 243–252. doi:10.1016/j.conbuildmat.2017.03.187.
- [4] Koh, Kyung Taek, Seung Hun Park, Gum Sung Ryu, Gi Hong An, and Byung Suk Kim. "Effect of the Type of Silica Fume and Filler on Mechanical Properties of Ultra High Performance Concrete." *Key Engineering Materials* 774 (August 2018): 349–354. doi:10.4028/www.scientific.net/kem.774.349.
- [5] AASHTO, "Load and Resistance Factor Design (LRFD) for Highway Bridge Superstructure," American Association of State Highway and Transportation Officials, FHWA-NHI-15-047, 2015. Available online: <https://www.fhwa.dot.gov/bridge/pubs/nhi15047.pdf>.
- [6] Buckner, C.D., "An Analysis of Transfer and Development Lengths for Pretensioned Concrete Structures," *PCI Journal*, No. 2, pp.84-105, 1995.
- [7] Reiser, Nicholas P. "Innovative Reinforced/Prestressed Concrete Bridge Superstructure Systems." PhD diss., University of Nebraska--Lincoln, 2007.
- [8] ASTM A416/A416M, "Standard Specification for Low-Relaxation Seven-Wire Steel Strand for Prestressed Concrete," *Annual Book of ASTM Standards*, American Society for Testing and Materials, 2018.
- [9] Song, Wenchao, Zhongguo John Ma, Jayaprakash Vadivelu, and Edwin G. Burdette. "Transfer Length and Splitting Force Calculation for Pretensioned Concrete Girders with High-Capacity Strands." *Journal of Bridge Engineering* 19, no. 7 (July 2014): 04014026. doi:10.1061/(asce)be.1943-5592.0000566.
- [10] Dang, Canh N., Royce W. Floyd, W. Micah Hale, and José Rocío Martí-Vargas. "Spacing requirements of 0.7 in.(18 mm) diameter prestressing strands." *PCI Journal* 61 (2016): 70-87.

- [11] Akhnoukh, A., Kamel, L., and Barsoum, M., "Alkali-Silica Reaction Mitigation and Prevention Measures for Arkansas Local Aggregates," *World Academy of Science and Technology Journal of Civil, Environmental, Structure, Construction and Architecture Engineering* 10 (2016): 95-99.
- [12] Akhnoukh, Amin K. "Implementation of Nanotechnology in Improving the Environmental Compliance of Construction Projects in the United States." *Particulate Science and Technology* 36, no. 3 (February 2, 2017): 357–361. doi:10.1080/02726351.2016.1256359.
- [13] Graybeal, B.A., and Hartmann, J., and Perry, V., "Ultra-High-Performance Concrete for Highway Bridges," *Proceedings of the Federation International du Beton Symposium, Avignon- 26-28 April 2004*.
- [14] Akhnoukh, Amin K. "Overview of Nanotechnology Applications in Construction Industry in the United States." *Micro and Nanosystems* 5, no. 2 (May 1, 2013): 147–153. doi:10.2174/1876402911305020010.
- [15] Morcous, George, Shaddi Assad, Afshin Hatami, and Maher K. Tadros. "Implementation of 0.7 in. diameter strands at 2.0× 2.0 in. Spacing in Pretensioned Bridge Girders." *PCI Journal* 59 (2014): 145-158.
- [16] Akhnoukh, Amin K. "The Effect of Confinement on Transfer and Development Length of 0.7 Inch Prestressing Strands." In *2010 Concrete Bridge Conference: Achieving Safe, Smart & Sustainable Bridges National Concrete Bridge Council Federal Highway Administration Portland Cement Association*. 2010.
- [17] Morcous, George, and Amin Akhnoukh. "Reliability Analysis of NU Girders Designed Using AASHTO LRFD." *New Horizons and Better Practices* (October 10, 2007). doi:10.1061/40946(248)81.
- [18] Girgis, Amgad F. Morgan, and Christopher Y. Tuan. "Bond Strength and Transfer Length of Pre-tensioned Bridge Girders Cast with Self-consolidating Concrete." *PCI journal* (2005): 73.