



ASSUMPTION COLLEGE

WORCESTER, MASSACHUSETTS | ROME, ITALY

Digital Commons @ Assumption  
College

---

Honors Theses

Honors Program

---

2020

## Mindset Matters: Using Research-Based Strategies to Enhance Middle-School Math Instruction

Catherine Harvey

Follow this and additional works at: <https://digitalcommons.assumption.edu/honorstheses>



Part of the [Educational Methods Commons](#), and the [Science and Mathematics Education Commons](#)

---

Running head: MINDSETS MATTER

MINDSET MATTERS: USING RESEARCH-BASED STRATEGIES  
TO ENHANCE MIDDLE-SCHOOL MATH INSTRUCTION

By

Catherine Harvey

Faculty Supervisor: Dr. Lisa D'Souza

Education Department

A Thesis Submitted to Fulfill the Requirements of the

Honors Program at Assumption College

Fall 2019

<b>TABLE OF CONTENTS</b>	<b>Page</b>
1. Table of Contents .....	1
2. Personal Connection .....	2
3. Introduction .....	6
4. Literature Review.....	9
a. Developing Growth Mindsets in Middle School	
b. Research-Based Strategies for Effectively Supporting Growth Mindsets in Math	
i. Praising Appropriately	
ii. Encouraging Mistakes	
iii. Promoting Resilience	
iv. Using Diverse Assessments	
c. Barriers to Supporting Growth Mindsets in Middle School Math	
5. Solving the Issue: Lesson Plans .....	32
6. Appendix A. ....	90
7. Conclusion .....	98
8. Unannotated Bibliography .....	99
9. Pictures Cited .....	103

## **Personal Connection**

You hear it all the time. People talk about how having a different mindset can enhance a variety of aspects of your life. Are they telling the truth? Can adopting a new mindset drastically change the way you live your life? Yes, in fact it can.

Life is a gift, a time full of opportunity, a never ending roller coaster of ups and downs, but most importantly life is what you make it. You can choose to live in a world that only involves you, closing yourself off to the rest of the universe. Or, you can put yourself out there and push yourself outside of your comfort zone, expanding and discovering who you are as an individual and as part of society. Your outlook on life says so much about the type of person you are and the mindset that you have developed. Do you have a growth mindset or a fixed mindset? Let's find out.

Hello, my name is Catherine Harvey I am 21 years old and live in upstate New York. Throughout my journey in this world I have learned a few things that I feel are necessary to share. As humans we are given a certain amount of power and control concerning how we decide to live our life and the type of mindset that we adopt. Life is going to throw many challenges and obstacles your way and these moments are critical in discovering the type of individual you are. I am writing to share a personal life changing experience that I had and explain how having a growth mindset changed my outlook on life forever.

Why am I sharing this experience? What impact does this have on anyone else? I have been studying at Assumption College these past four years to get my bachelor's degree in mathematics and secondary education with the hopes of becoming a high school math teacher. I

have learned that having a growth mindset can be directly applied to the classroom, specifically mathematics and I cannot wait to share my research and impact the lives of my future students.

The spring of my sophomore year of college I was faced with true hardship for the first time. It started when I received my fourth concussion from cheerleading. This concussion took me for a ride because it lasted over a year leaving me feeling dizzy, with headaches every day. This affected me physically and mentally. There was nothing I wanted more than to feel better. I was continually upset and feeling down as I was in and out of doctor appointments nearly every day. I tried to keep up my normal activities, but it was hard for me to concentrate on my school work. I was constantly stressed that my grades were going to drop and that this concussion was never going to go away. In other circumstances I would go to the gym to combat my stress but unfortunately, I was not allowed to do much physical activity until my head was healed. As the months went by, my sadness and frustration increased, and my head was not healing. One summer morning I woke up feeling really sick and decided to call out of work. As time went on, this sick feeling and my post concussive syndrome head issues were nonstop. I grew weak as I was not eating. I went to numerous doctors about stomach and intestinal issues and I was prescribed medication after medication and a handful of tests. Nothing was working for me and they could not find anything in the tests. I stayed in bed most days contemplating life wondering why all of this was happening to me. I wanted more than anything to be able to go to work, hang out with my friends, and live the normal life that I once had.

Finally, I hit a wall and really started to lose it. I was put on anxiety and depression medication and everyone really started to worry, including myself. I could not seem to get myself out of this terrible funk. I saw two psychologists and talked to counselors trying to get

help. I remember telling them that if I felt better than I would not be upset anymore. Everyone kept telling me that I just needed to relax and take my mind off things and I would eventually feel better. However, I did not believe them and just continued to think that nothing was going to change, and this was how my life was going to be forever.

Eventually it was the end of August and time to go back to college. However, I did not want to go back and cried many times over it. I could not help but think why I would not want to go back to one of my favorite places in the world. I loved college but was convinced that I was too sick to go back. One afternoon I was talking to my grandparents, who are my favorite people in the world. They stressed to me the importance of going back to school and told me how much they thought it will help. They told me that if I go to school, focus on my work, and surround myself with my friends I will start to feel better and become my old self again. As hard as this decision was, I decided to take a leap of faith and trust them, and I could not be any happier that I did.

However, it was not as simple as just taking a car ride back to school. I had to change my entire outlook on life and to do this I needed to adopt a growth mindset. At the time I did not know what a fixed mindset was, nor did I think that I had one. I had no clue that I was holding myself back by thinking that things were never going to change and that my life was going to stay like this forever. However, eventually I started to adopt a growth mindset which allowed me to see that I can change and grow into a stronger person. Once I started to think like this, I started to feel better. I focused on my school work, hung out with my friends, and ate like my old self. I started to feel happy with who I was again, even though my concussion was still not fully gone. There were days that I did struggle and easily could have fallen back into the fixed

mindset that I used to have, but I did not let that happen. I kept pushing myself and keeping the growth mindset mentality allowed me to see that there would be better days ahead.

Here I am today. My concussion has finally healed, but I am not the person who I was before this journey. I am so much stronger. I have a growth mindset which I carry through all aspects of my life. I am constantly looking for ways that I can improve and do whatever I can to push myself to achieve all my goals. As hard and as painful as it was, I am so thankful for this experience because I know that this mindset will help me in my future endeavors. The takeaway I got from this experience is the defining point behind having a growth mindset; you can never move on or get stronger if you do not mentally believe that you can.

This experience has opened my eyes and has allowed me to better prepare myself for my future as a secondary mathematics teacher. Having the knowledge that many of my students may come to class with a fixed math mindset will allow me to tailor my instruction to fit the needs of my students while promoting a growth mindset in my classroom. I want to make a difference in my students' lives and promoting a growth mindset will hopefully provide them with an eye-opening and life-changing experience.

## INTRODUCTION

Picture this scenario in a middle school: It is a sunny Friday afternoon and Johnny just got back his math test. He received a 100% and is so excited. The whole day all Johnny can think about is how eager he is to tell his parents because he knows that they are going to be so proud of him. As soon as the bus stops Johnny runs off, barges through the door, and shouts to his parents that he earned a 100% on his math test. His parents are so happy. They say “you are so smart! Math has always been so easy for you!” Then they ask Johnny to choose his favorite restaurant to celebrate for dinner tonight. This makes him so happy because he got rewarded for being “smart” in math.

Now picture the same day with a very different scenario: It is that same sunny Friday afternoon and Sally, Johnny’s classmate, earned a 50% on the math test and is really upset about it. On the bus ride home, she thinks about how scared she is to tell her parents. When she walks into her house, her parents ask her why she’s upset, and she tells them that she received a 50% on her math test. They don't yell at her or take away her cell phone. In fact, they tell her that it is okay because she can grow and learn from this. They praise her for making mistakes and tell her to go back through the test and work through the problems again. If she needs help working through the solutions, they tell her they would be happy to support her or bring her to school for extra help. Working through the incorrect problems will help Sally identify where she went wrong and where she might make mistakes in the future. Sally’s parents praise her willingness to try again, even though it is not easy and she will continue to make mistakes as she learns. With their support and encouragement to learn from her mistakes, Sally feels better and becomes more motivated to identify her errors when she is studying for her test.



So which situation is a more positive learning experience? You are probably thinking Johnny's, right? Wrong. Sally's situation is actually better. Sally's parents responded in a way that promotes Sally's growth as a student. Instead of punishing Sally for receiving a failing grade, they encouraged her to go back and look at her mistakes to learn from them. This motivated Sally to grow as a student as she can now approach future tests differently. Johnny's parents on the other hand, did not respond in a way that is going to help him grow as a student. When Johnny received a 100% on his test, his parents could have recommended that he find additional ways to challenge himself if the math the test was too easy. Additionally, they praised and rewarded him by allowing him to pick a restaurant for dinner. This behavior is also not going to help Johnny grow as a student because they are praising him for his intelligence by telling him he's always been so smart in math rather than praising him for his hard work that he put in to earning his grade.

This new type of behavior may seem foreign to some people and sound completely crazy, but this can be traced back to the strategies that teachers use in their classrooms and the effect they have on their students' mindsets. Being a truly effective teacher requires a lot more than just showing students how to solve problems and giving them a test on it. In today's educational world, traditional teaching practices are being abandoned and teachers are beginning to take a non-traditional approach. Teachers are not only changing the way they teach material, but they are also changing how they assess their students and develop their minds mentally in order to push them to be as strong academically as well as promoting their intellectual curiosity. To do this teachers are being told to use new effective strategies that will promote a growth mindset rather than a fixed mindset in their students. However, there are a few existing barriers that stand in the way from allowing this to happen.

The question I sought to answer in my thesis is: How can we support math teachers' use of effective strategies to create a growth mindset in students?

## Literature Review

Dr. Carol Dweck, Professor of Psychology at Stanford University, has changed education forever due to her substantial research on “Growth Mindset.” “In a growth mindset, challenges are exciting rather than threatening. So rather than thinking, oh, I’m going to reveal my weaknesses, you say, wow, here’s a chance to grow.” – Carol Dweck. According to Dweck, “a mindset is a self-perception or “self-theory” that people hold about themselves” (Dweck, 2016). An example of a mindset is believing that you are either “smart” or “not smart.” There are two types of mindsets that a student can have, fixed mindset or growth mindset. When students have a fixed mindset, they believe their basic abilities, intelligence, and talents are just fixed traits and static, see Figure 1 for a visual depiction. They are convinced that they have a certain amount they can learn and once they reach that level they cannot learn anymore. Their goal then becomes to look smart all the time and to never look dumb. This means students intentionally choose easy tasks and never risk a challenging problem or assignment for risk of failing. Carol Dweck argues that a growth mindset, on the other hand is quite different. When students have a growth mindset, they believe their abilities can be developed and they can always learn more and that there is room for improvement. Current trends in the education world wants teachers to promote a growth mindset within their students, but it requires specific recognition of the barriers and the strategies for successful implementation.

Figure 1. Two Mindsets

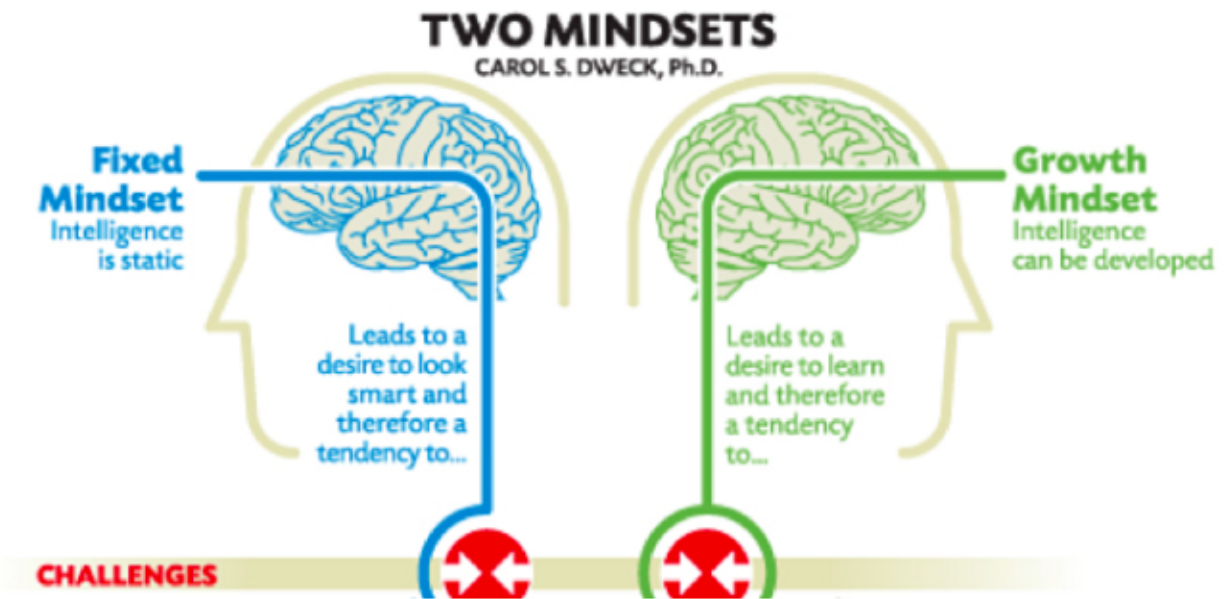

(Lean Enterprise Institute, 2019)

In preparation for my journey as a secondary math educator, I focused specifically on the teaching styles that math teachers can use in their classrooms. Math is that subject in school where you hear “I hate,” or “I am so bad at” the most. According to the Times Union Newspaper, a poll was taken by 200 middle school students asking them to identify their favorite and least favorite classes (Gish, 2012). 40% of students voted that their least favorite class was math. These results are directly related to the student’s math mindset that they have developed over their years of traditional education. Today’s teachers can reduce this mindset from developing by incorporating different strategies and thinking outside the box to create a stronger, positive image of math in their students’ minds.

Educators have begun to see how much a growth mindset can affect the achievement of their students. This is when society started to question, do we have the ability to change

mindsets? and If so, then how? Through various experiments and tests, educators developed a new plan of intervention and it started with a series of effective strategies.

Figure 2. A Growth Mindset Drives Motivation and Achievement



(Mindsetworks, 2017)

To prevent students from developing a fixed mindset and to promote a growth mindset classroom, teachers need to go above and beyond. Most teachers take an active role when teaching but sometimes in today's society that is not enough. When teachers strive to design challenging, meaningful learning tasks, their students are going to react differently to these tasks based on the type of mindset they have developed. Students with a fixed mindset may be nervous to take on challenging problems, while students with a growth mindset may show excitement towards these types of problems. To promote a growth mindset classroom, teachers are told to provide the right kind of praise and encouragement, emphasize that fast learning is not always the best way to learn, and have their students identify areas that they think they need to improve on.

There are many strategies that the education world wants teachers to incorporate into their lessons that can promote a growth mindset in their students and classroom environment. Some of these strategies include praising students in the right way and remembering that whatever you say as a teacher sends a message to your students. Additionally, the education world wants teachers to remember to encourage mistakes. Teachers can do this by going over homework in a way that promotes resilience. Finally, they are told to modify problems to fit the needs of all their students. To do this they can create balanced tests, use multiple representations, ask open ended questions, and try to incorporate writing into their math lessons.

### **Praising Appropriately**

When a teacher praises a student in the wrong way it can have a negative effect on that student. “We often hear these days that we've produced a generation of young people who can't get through the day without a reward. They expect success because they are special, not because they have worked hard” (Dweck, 2016). This is a common problem that is seen in today's schools because most teachers believe that praising students' intelligence builds motivation and confidence, when in reality, it is doing the opposite. Carol Dweck (2010) conducted a study in NYC on a group of 100 7<sup>th</sup> grade students. The study was done to see if teaching students to have a growth mindset would help their achievement. The students were broken up into two groups and each given eight study sessions. One group got six sessions of study skills and two sessions on growth mindset, while the other group got eight study skill sessions. During the growth mindset sessions, the students received an article on how to grow their intelligence and were informed that their brain grows just like muscles. This made students excited to learn as they believed they had the ability to achieve so much more than they thought. The results showed

that students who had a growth mindset performed significantly better and were more eager to learn and take on challenging problems than students with a fixed mindset. There was another study that was conducted by Carol Dweck in 2016 to show the impact of praise on resilience after failure. The study started by having students take an exam on content they had never seen before, resulting in failing grades for everyone. Proceeding this pre-test, students were broken up into two groups to learn new math content for a week followed by a post-test. One group of students were praised for intelligence level and the other group was praised for effort. The results proved that praising students for their hard work and effort instead of their intelligence made students stronger and is shown in Figure 3. The results also showed that students who were praised for their intelligence later lied about their score on the post-exam to their peers and parents. This meant that their errors were so humiliating that they could not own up to them. This can be related to Johnny's case as he would be one of the students praised for their intelligence rather than their work ethic.

Figure 3. Impact of Praise on Resilience After Failure

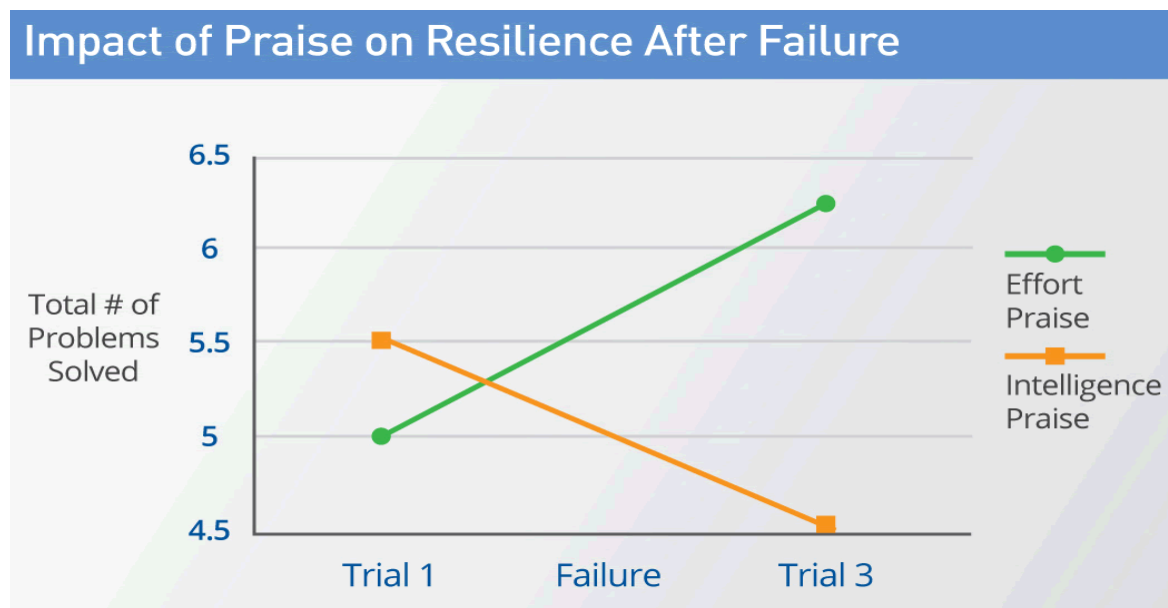

(mindsetworks, 2016)

## **Encouraging Mistakes**

Everything that teachers and parents say, sends a message to their students. These messages can either enhance a student's learning or threaten it, which is why it is important for mistakes to be encouraged and praised. In a survey given to parents, over 80 percent of parents thought it was necessary to praise their children in order to boost their confidence in their abilities to help them succeed (Dweck, 2010). However, what parents don't know is that there are much more effective ways to boost their child's confidence and teachers can help this issue in their classroom. If teachers are telling students to not make mistakes and if they do, to not repair them, they are essentially telling their students to not work hard and are promoting a fixed mindset. Nevertheless, if parents and teachers are telling their students to take on challenges, work hard, and confront their weaknesses and correct them, this is going to promote a growth mindset amongst their students.

When a student does not receive a perfect grade on an exam, the student must have made at least one mistake. "When a student makes a mistake, their brain is actually given more of an opportunity to learn and grow" (Boaler, 2016). One of the best ways for students to learn is to learn from their mistakes as they can train their brain to not make them again, which is what Sally did in her case. This is called muscle memory and it should be emphasized and praised in the classroom. Muscle memory is when your muscles are able to reproduce a particular movement without conscious thought (Merriam-Webster). Muscle memory in the brain can help you grow because if you are unconsciously able to make mistakes then your brain will constantly be developing and learning from them. If teachers don't encourage students to make mistakes then not only are they going to learn less, but the students may feel ashamed if they do make a mistake which will have a direct effect on their mindset.



Going over homework can be a very effective strategy to encourage mistakes while promoting a growth mindset when done in the most practical way. Going over homework in class the next day can be beneficial as it gives students an opportunity to communicate their mathematical answers, allows students to see multiple solutions, both correct and incorrect, and gives students an incentive when completing their homework. “Focusing on correct solutions may limit the payoff of going over homework because it fails to use incorrect student responses as launching points for discussion, which can be beneficial to student learning” (Otten, 2015). When students see other classmates’ thought process for their mistakes, their mathematical growth mindset will grow stronger as the class can go over common misconceptions and alternative ways to approach problems. If students are only provided with correct solutions, then they will not be able to trace their path between an incorrect answer or a mistake with the correct response.

### **Promoting Resilience**

Promoting resilience is another proven effective and important strategy to promote a growth mindset. “Resilience is the capacity to recover quickly from difficulties and toughness” (Yeager, 2012). According to Locke, Campbell & Kavanagh, overparenting also known as helicopter parents is a serious concern that is affecting student’s ability to think resiliently (2012). Locke, Campbell & Kavanagh cite, the widespread belief that the modern world is more dangerous fuels the increasing trend of overparenting. When parents do this, they are actually hurting their children as they are not allowing their children to live in the real world and fight their own battles. This will affect them when they are presented with challenges and tough times as they will not know how to fight through these situations on their own resiliently. Students ability to think resiliently can be tied to social labels as well. For example, if students are labeled

as nerds (hardworking and bright individuals) then they have a higher self-perception of themselves, are held to higher standards and achieve at a higher level. However, if students are labeled as slackers (lazy, avoids work) then they will have low self-esteem, lower expectations, and will not achieve as high. (Figure 4) Adolescents believe that social labels, once acquired are fixed entities that cannot change. This belief is most likely due to social media and its dramatic effects on our society. Every student is going to face adversity at some point in their life, whether it be educational or social. Teachers are encouraged to prepare students for this moment by teaching them to respond resiliently. Teachers should tell students to have a mindset that embraces and sees challenges as things they can take on and overcome with effort and patience. If teachers show their students that they have the potential to change than they are preparing their students better for when life throws challenges their way.

Figure 4. Labelling and the Self-Fulfilling Prophecy

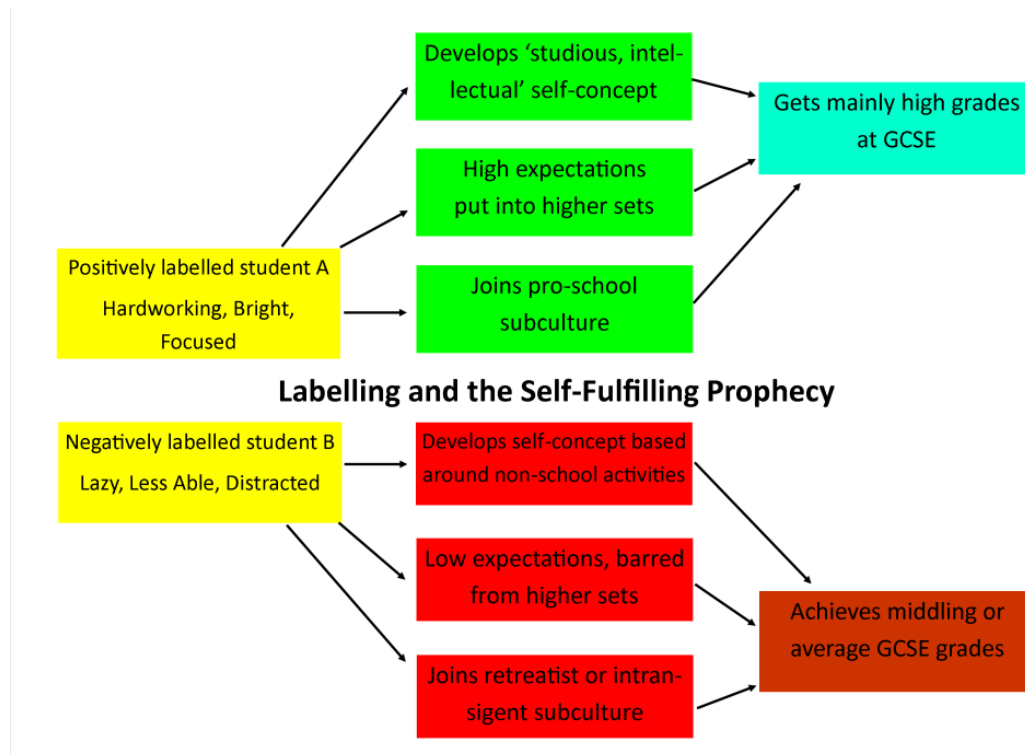

(revisesociology.com) [GCSE = General Certificate of Secondary Education – Education qualification tests taken by 16 years old's]

## Using Diverse Assessments

Using a variety of assessments can be extremely beneficial in a math classroom because all students learn differently. Students comprehend math on different levels and at varying paces so using diverse assessments can fit the needs of all types of learners, challenging the ones that perform at a high level and allowing students that perform at a lower level to fully understand the content. Presenting material in a variety of ways also allows students to make more meaningful connections but in a way that allows for self-discovery of solutions. Some of the diverse assessment strategies that teachers can incorporate include selecting appropriate problems, taking a non-traditional approach, creating balanced tests, and asking open-ended written questions.

Selecting appropriate problems for student assessment is called problem analysis. This is the process in which teachers modify a math exercise to emphasize process over product to help students at all levels meet the requirements of today's math standards. When textbooks are outdated it makes it challenging for both teachers and students. "Problem analysis can help cope with this problem as it is the process of examining a math problem and modifying it to create a better learning experience for the students regardless of their level of knowledge" (Garcia, 2014). Teachers can do this by modeling problems and walking through the first few steps as a class. This allows students to experience various aspects of the problem. Modifying the problem is beneficial to struggling students as teachers can target specific parts of the process. It also helps maintain rich mathematical ideas to challenge students, which is something that is rarely seen in today's classrooms. It is targeted at the grasping process rather than solely focusing on the outcome. This is beneficial to students' math mindset because teachers are ensuring that every student is working on problems at their level. This prevents students from feeling like they are

not good enough or comparing themselves to their peers which is something that holds many students back.

A similar strategy is to consider solving problems in a non-traditional way. For example, let's think about functions. The traditional way that teachers have taught functions focuses on a one-way connection between a graph, table, and the symbolic representation (Rider, 2007). However, when students are asked to reverse this effect, they are unable to do it because their brain has only been taught in one way. Students can only reciprocate information the exact way that it is taught to them in class. They are not able to use higher order thinking and push themselves past the one representation. When teachers take a non-traditional approach, they can teach the content in multiple representations. An example of a non-traditional approach to math is the use of technology and manipulatives, to help students understand mathematical concepts with models. “The potential of virtual manipulatives for improving the quality of mathematics education is very promising since everyday new non-traditional activities and websites are developed for designing virtual manipulatives for some area of mathematics” (Durmas & Karakirik, 2006). Using virtual manipulatives teach students how to communicate their mathematical ideas and gives students a better opportunity to learn the content more fully by making deeper connections. Some examples of virtual manipulatives include coins, base ten blocks, and algebra tiles.

Creating balanced tests is also beneficial to all levels of students. To create a balanced test, teachers need to follow the pyramid model (see Figure 5.), where students demonstrate proficiency at solving problems in all three levels of the pyramid. The three levels of the pyramid are (1) reproduction of knowledge of facts and definitions, (2) making connections, and (3) generalizing mathematically (Dekker, 2007). Teachers are told to remember that if they are

asking level two or three questions on a test then they need to ask those types of questions to their students in classroom discussion too. Following this system when generating a test allows teachers to still give partial credit to students who maybe just succeed at the first level of the pyramid, but also allows teachers to push students to develop a deeper meaning by making connections (Dekker, 2007). When teachers give a balanced test rather than a test that only has level one questions, it promotes a growth mindset. It shows students that their brain can take a concept at level one and push their level of knowledge to answer a level two or three question.

Figure 5. Assessment Pyramid

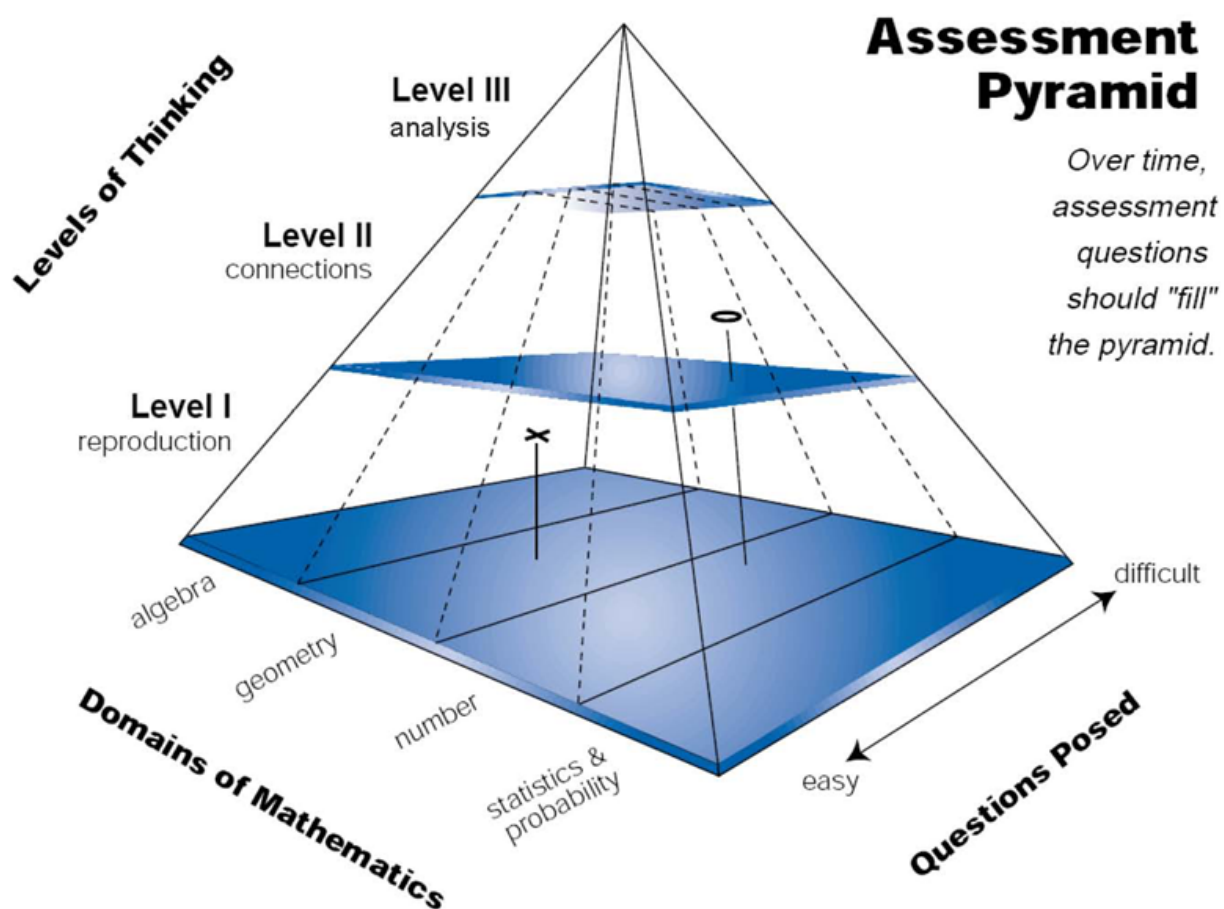

(Freudenthal Institute US)

Another way math teachers can assess their students in a beneficial way is by incorporating writing through inclusion of open-ended questions into their lessons. “Allowing students to write in mathematics class can promote critical thinking, illustrate an awareness of mathematical connections, and result in clear communication as they share many of their ideas with their peers” (Haltiwanger, 2013). When most students look back at their math career, a large majority will say that they have never done writing in math class, unless it was putting their answer in a sentence at the end of a problem. There are a few strategies that teachers can use to incorporate writing into their math lessons. Some of these strategies are: Word Problem Roulette, Three-Way Tie, Cinquain, and M + M: Math and Metaphors. Word Problem Roulette is a strategy that helps students explain their critical thinking when solving problems. One student writes the first step of the problem and then passes the paper to the next student who writes the second step and they continue this process until the solution is complete. Three-Way Tie is a way for students to make meaningful connections between three math terms in a triangular guide. Cinquain is a five line poetic structure where students write a poem based on a math concept. This strategy is effective because it allows students to expand on their current knowledge. M + M Math and Metaphors is a strategy that allows students to compare math terms or concepts to real world objects. This is beneficial to students because it helps them remember definitions by affiliating words with everyday items. In Figure 6, we can see a graph that shows the positive effects of writing intervention in math. A class of middle school math students was divided into two groups, the growth group was exposed to writing in math every day of the week while the control group was not. At the end of the week the students took a test and the growth group performed significantly better on the exam than the control group.

Figure 6.

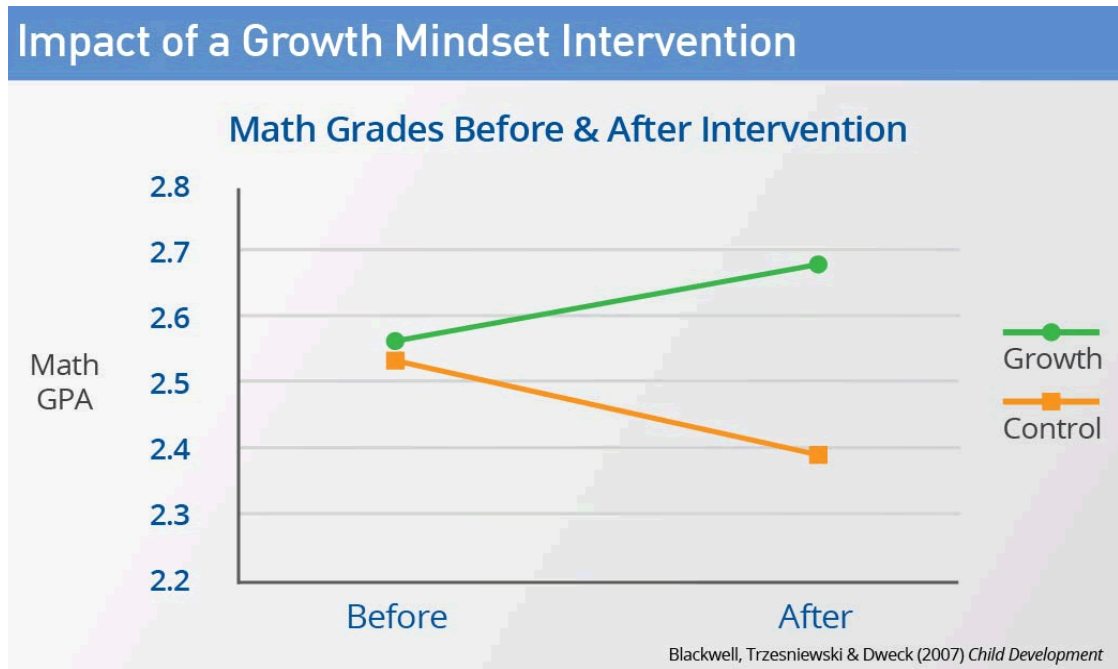

(mindsetworks, 2017)

### **Barriers to Implementation**

Even though all of these strategies have been shown to promote a growth mindset and be very beneficial to students in math class, there are barriers that need to be considered before successful implementation. Some barriers prohibit teachers from effectively incorporating these strategies into their lessons: length of the class period, financial constraints, student accountability and attendance, lack of support from home, behavioral issues, state testing, class size, and excessive stress.

Depending on the school, most high school classes run on average for approximately 45 minutes (Felton, 2014). In this time teachers are expected to effectively check for understanding on the previous day's lesson, teach an entire new lesson, and prompt students in the direction for tomorrow's lesson. Now the educational world wants teachers to incorporate these new

strategies into this small time period to be even more effective. The fact that teachers are so tight on time, makes it very hard for them to promote mistakes in their classroom. Teachers are encouraged to go over both correct and incorrect solutions when students make mistakes to identify common misconceptions with the entire class. Even though this strategy is proven to be effective, when are teachers supposed to squeeze this in to their allowed 45 minutes? Additionally, teachers are encouraged to incorporate writing into their classroom. Yes, writing is beneficial as it helps to show that students have a deep understanding of the content. However, writing also takes up a significant amount of time, making it very challenging for math teachers to incorporate it into their lessons.

Money is a huge barrier, especially for schools located in areas with lower socioeconomic status. According to the Education Law Center and the Rutgers Graduate School of Education, school funding levels vary drastically among school districts, which plays a direct effects on the students in these districts. The no child left behind reform was supposed to close the achievement gaps amongst students of different backgrounds. However, still today in 17 states, the school systems “provide less funding to their higher poverty school districts, even though students in these districts require more resources to achieve” (Chen, 2018). Additionally, the worst-funded states tend to neglect effective educational intervention plans that could close the achievement gaps by underfunding schools and paying their teachers low wages. In Figure 7. you will be able to see individual states general funding per student and how the numbers are still trailing far behind what they were before the economic recession. A lot of the newly developed strategies require teachers to have certain types of technology and resources. For example, there are plenty of online resources such as Desmos, an online graphing calculator that allows students to input data to a graph and see the direct effects on the graph. Some school



districts cannot afford to provide teachers with the adequate resources they need to be highly effective. This leaves teachers stuck using old textbooks, but required to teach current material, putting a challenge on both the teachers' effectiveness and the students' learning. How are teachers supposed to teach in non-traditional ways using multiple representations when all they are provided with are old textbooks and a chalkboard? This demands teachers to spend a great deal of time outside the classroom to figure out how to teach in a non-traditional way with traditional resources. There is no way that teachers have all this extra time which makes it very hard to incorporate these strategies in underserved districts.

Figure 7. State General Funding Per Student

### State General Funding Per Student Still Far Below 2008 in at Least 12 States

Percent change in state formula funding\* per student, inflation adjusted, fiscal years 2008-2018

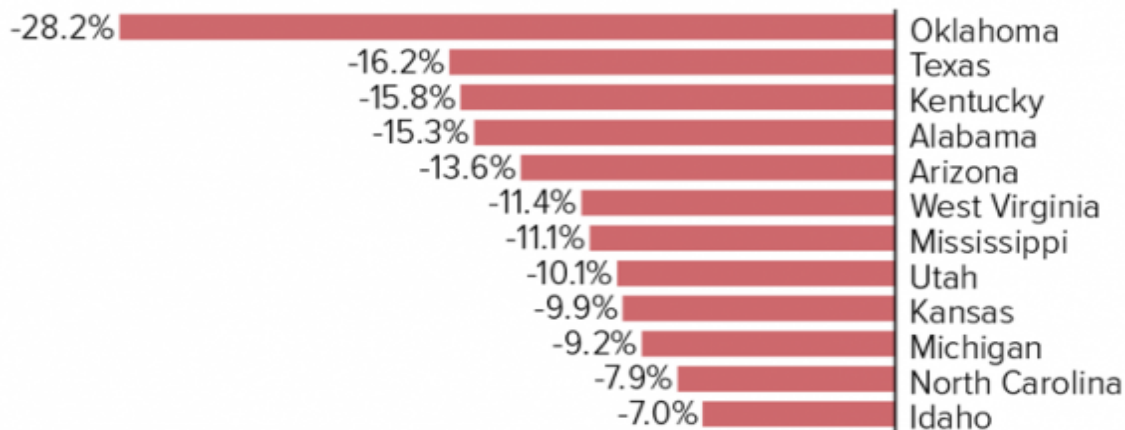

\*General or formula funding is the primary form of state K-12 funding. States also typically provide revenue for other, more specific purposes, such as bus transportation and contributions to school employees and pension plans.

Source: CBPP budget and enrollment analysis.

CENTER ON BUDGET AND POLICY PRIORITIES | CBPP.ORG

(Center on Budget and Policy Priorities, 2017)

Another barrier is chronic absenteeism. A teacher can effectively teach a lesson, but if students are not taking accountability for their part by coming to class, they are not going to

learn. Chronic absenteeism is a hidden education crisis as attendance is a growing problem in many high schools. To be considered chronically absent students need to miss 15 or more days of school and in 2015-2016 over 7 million students (16 percent of the student population) were at this point (Department of Education, USA). In Figure 8, you can see the students that were chronically absent in different races. Not only are these students going to fall behind, but if a student is not present in class, then they are unable to learn and grow. Also, if a teacher assigns homework and is expected to go over it in class the next day but the students don't take accountability and do their homework then they are not going to benefit from the review. Now the teacher is left with the ultimate challenge of teaching new content while reviewing yesterday's content all within a 45 minute period.

Figure 8. Chronically Absent Students in 2015-2016

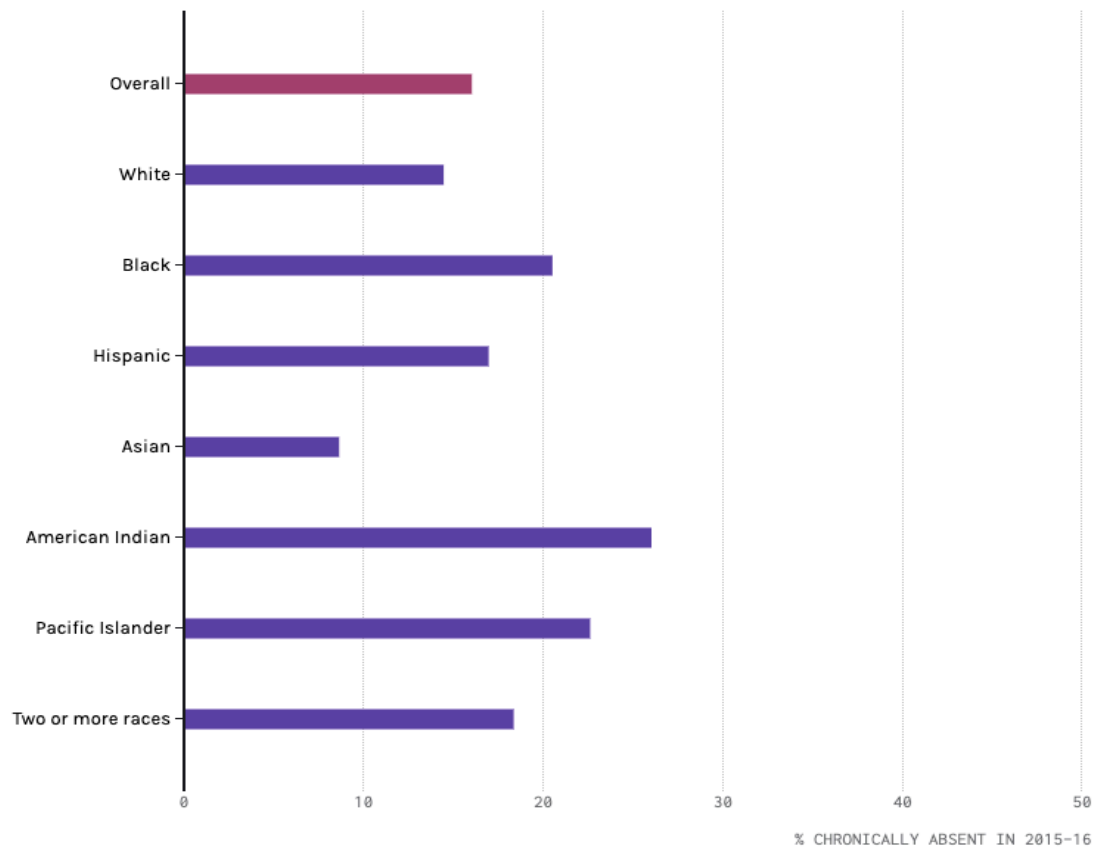

(Department of Education, USA)

Accountability from parents, guardians, and family is essential. When families encourage learning at home and involve themselves in their child's education, student success increases dramatically. In 2016, research showed a decrease in parents who thought that personal parent-teacher communication is effective. "Parents now prefer remote methods of communication, like online student portals, and they are less likely to attend parent-teacher conferences or school activities" (Waterford, 2018). Another benefit to parent engagement is that it decreases chronic absenteeism as parents are actively involved with their child's academic life. When students leave the classroom there is not much else the teacher can do. At home parents need to push their students to get all their homework and school work done before going off and doing other activities. This promotes a growth mindset because it teaches children time management which allows students to push themselves in all aspects of life while still having a balance between school and extracurricular activities. If the family does not promote a growth mindset environment at home, then the student is less likely to do any work outside of school. Additionally, the type of praise that families say to their children can affect their child's mindset. If parents are like Johnny parents, then their child is going to end up having a fixed mindset. However, if parents are like Sally's parents and sending the right type of message to their child then their child is much more likely to have a growth mindset.

Additionally, another barrier is student behavior. Multiple studies have been done that examine the correlation between behavior and academic performance. A recent study revealed that among a sample of 352 mainstream secondary school students that were underperforming academically had significantly greater social, emotional, and behavioral difficulties. (Joffe & Black, 2012) The study was performed to identify whether students who were not performing

well academically were at risk for developmental and behavioral problems. During the study the students were given the Strengths and Difficulties Questionnaire (SDQ), which is commonly used for screening students. The SDQ consists of 25 items equally divided across five scales measuring emotional symptoms, conduct problems, hyperactivity-inattention, peer problems, and prosocial behavior (Stone, 2015). The purpose of screening students is to help provide them with the appropriate tier of support without taking away from their or their peers educational experience. If a teacher has students in their classroom that have behavioral issues, then this takes away from the time the teacher gets to teach and affects the rest of the class. If a teacher is constantly dealing with a few students who are behaving inappropriately then a lot of that teachers' energy is going to be directed towards those students. On the flip side, if the teacher just sends the misbehaving students to the principal then they are missing out on quality content that they are going to need to know and make up at some point. How are teachers supposed to find the time to promote resilience in their classroom when some of their students cannot even behave in an appropriate manner? Behavior is a critical aspect of having a growth mindset. If students are misbehaving and acting like they don't want to learn and succeed in the classroom then this may be attributed to a fixed mindset.

State testing is another growing barrier that inhibits teacher autonomy. Teachers are required to teach a certain amount of material in order for students to perform well on state tests. Then their students' performance on these state tests has a direct effect on their teacher evaluation of them as a teacher (Dillon, 2010). According to Figure 9, in New York State 20% of a teacher's evaluation comes from their student's success on state tests. With all of this being said teachers can not stray far from state test curriculum which prevents teachers from being able to go in-depth with content. The educational world is encouraging teachers to create balanced

tests but to do this teachers would have to stray away from the style of state tests. This puts students at a disadvantage come time for the state tests as they will not be familiar with the style of questions on the exam. This may affect the students' performance on the exam negatively, which then reflects the teacher in a negative way.

Figure 9. NYS Teacher Evaluation

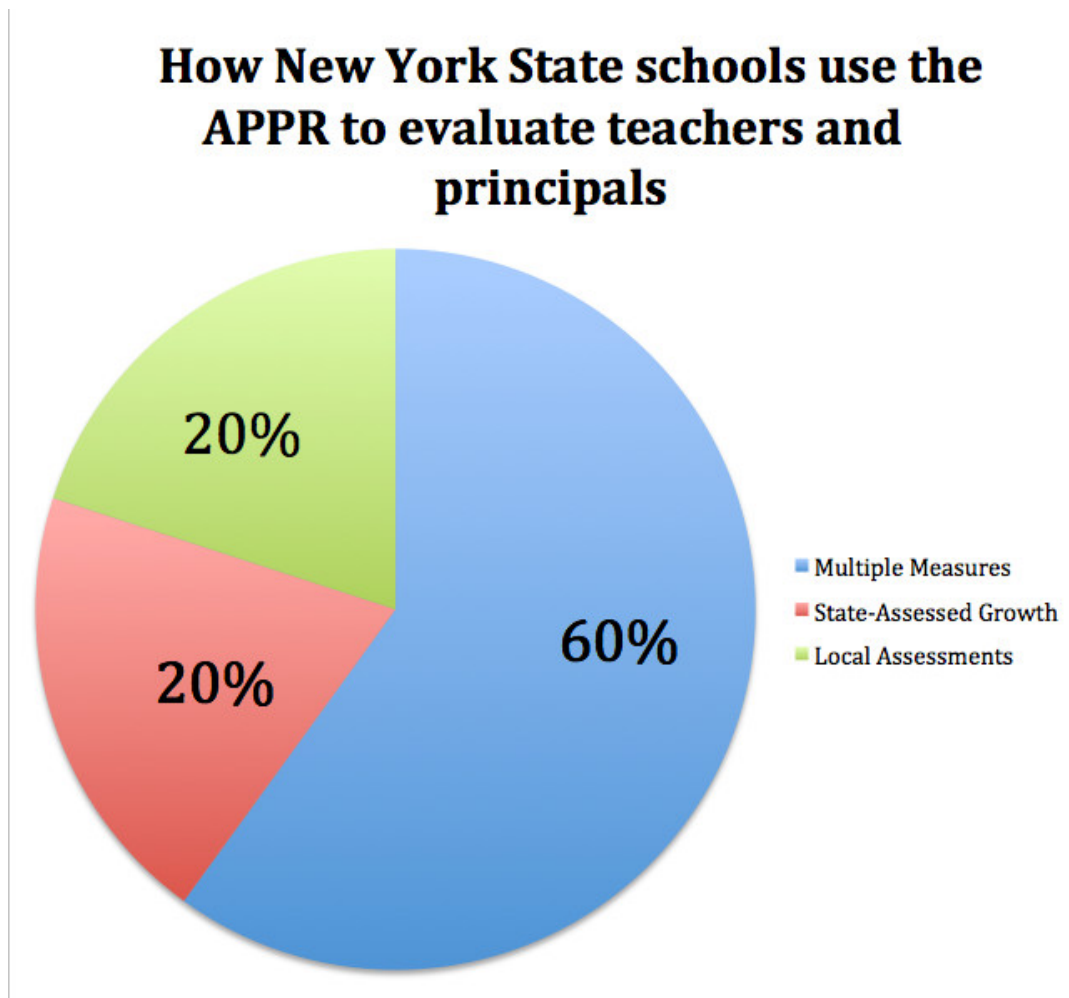

(Parker, 2014)

Another barrier to implementing a growth mindset is class size. The average American high school class size is about 23 students (Rampell, 2009). In Tennessee there was a study done

on class size and its effect that it has on student's success. The study included 79 schools, 300 classrooms, and over 7,000 students and was done over a period of four years. According to the student testing done over the years, the results showed that the students in the smaller classes performed better than the students in the larger classes did (Cromwell, 2006). The smaller the class size, the easier it is for teachers to be effective. However, if teachers have a large class of 25 to 30 students, effective teaching remains more challenging. For example, to test that students have a full understanding of content, teachers are encouraged to ask open-ended questions in a class discussion. In a class of about five students it is a lot easier to ask these types of questions and assess students understanding. In a class of 30 students, if you ask a few open-ended questions then you only end up hearing from about 20 percent of the class. This does not allow you to assess the understanding of each student as teachers are encouraged to do through this strategy.

A final and very critical barrier are the rising levels of stress felt by students today. Teachers work with students in a very critical point in their lives as students are faced with a multitude of challenges and fluctuating emotions. Adolescents are full of stress and always in the process of re-evaluating who they are and what they want to be. The stress and pressure placed on students today has created a mental health crisis for many young people. Stress comes from all aspects of the students' lives including physical, parental, social, and academic. Teachers can tailor instruction to the needs of their students by implementing strategies that will promote a growth mindset in each student, both in and out of the classroom.

Stress is impacted by many factors facing adolescents today. The first initial stress that is placed on students is physical as their body is constantly changing. These physical changes put a stress on students as they cause them to feel uncomfortable with their body and makes them self-

conscious about what those around them think of their appearance. “Nowadays boys are bombarded with body-image obsessions almost as much as girls. Muscles. It’s all about muscles” (*Not Much Just Chillin’*). This physical development stage can really affect a student if they are constantly worried about how they look and feel because it can lead to a decrease in concentration on school work. Eventually this can lead to a spiral of events, but teachers have the opportunity to prevent this stress from getting out of hand in their students. It starts by promoting a growth mindset to address that body image is a working progress and let the students know that the awkward stage will pass.

Another stress that many students are faced with comes from the pressure of parents. Some parents put a lot of pressure on their children to perform well in school in order to get into a good college. This not only causes students to stress but makes them fixated on the grade they are getting rather than the content they are learning, which is promoting a fixed mindset rather than a growth mindset. For most parents, I don’t think they even realize they are putting this pressure on their child, they are just happy their child is getting high grades. In the documentary, *Race to Nowhere*, “Parents say, 'My child is a good kid.' No, they were a good performer. You never found out if they were a good kid. You just know they're a good student, not a good solid kid.” This line from *Race to Nowhere* really stood out to me because it is something that is seen quite frequently and needs to be addressed. Teachers can step in to fix this problem and ease the pressure students are feeling from home, by having their students adapt a growth mindset to value the importance of their education.

Social life is another stress students are faced with as their friend groups are constantly changing. As students ditch old friend groups and create new ones, this leads to a separation and hierarchy based on popularity. Students feel this constant need to fit in and be on the same level

as the “popular group.” Students will change their appearance, hobbies, values, and wardrobe just to fit in and try to feel popular. “Crushes slip to number five on her priority list, or even six, as Jackie lands firm-footed on a new fixation: identity” (*Not Much Just Chillin’*). Students want to change who they are and become someone different in order to fit in. This is not something that is only prominent in girls as a lot of boys will change their behavior or get into trouble just to look cool and tough in front of their friends. Students who lose their old friends and feel like they don’t fit into a new group tend to get very upset. This leads to isolation as they spend a lot of their time alone and can eventually cause different types of mental illness such as social anxiety. By promoting a growth mindset classroom environment teachers can try to address this issue by letting students know how much their self-worth is.

Finally, the biggest stress that students are faced with is the stress of the school work itself. Students today are overworked and it is affecting many students mentally and physically. Homework is the leading factor behind this as students go to school for seven hours and then have to come home and squeeze in hours of homework into their after school life. This can be very hard for students who play sports or do other activities as they usually have practice or meetings after school. This causes students to not have time for basic functions such as sleeping or eating, let alone just being a kid. A parent of a child in *Race to Nowhere* said, “These kids are so overscheduled and tired that I’m afraid that our children are going to sue us for stealing their childhoods.” Students don’t have time to play or hangout with friends because of the amount of work they have. It is recommended that students get ten hours of sleep and most only end up getting about six or seven. When students are overtired from the night before they are not going to be able to focus on school work and will not take in any of the information the teacher is saying. Some students try to have (make) extra time for homework by skipping meals which



may lead to eating disorders such as anorexia. Additionally, students with test anxiety try to cram and memorize everything last minute just to get a good grade on the test. These problems are growing as teachers are assigning more work trying to meet the standards and deadlines they need to follow but can be addressed and fixed by the teacher.

Being a teacher comes with a huge responsibility but also a huge reward in return. There is no better feeling than knowing that you are making a difference in your students' lives. Students go through a lot of changes; physically, mentally, socially, and outside of school while you are working with them. All these changes and pressures can cause students to develop different mental and physical health issues. Teachers have the ability to make a change in their students' lives by taking an active role to promote a growth mindset and adapt instruction to meet their needs. It takes a very passionate teacher to allow students to develop and grow both in and out of the classroom, but the results make all the extra effort worth it.

Creating a growth mindset classroom, where students come into class knowing that they are going to learn and improve their math skills is challenging for the teacher. It requires an immense amount of planning as teachers are deeply thinking through every strategy that they are going to use, work to overcome barriers that may prevent these strategies from being implemented, and identifying ways to help students overcome mental challenges they may have. This requires a lot more work outside of the classroom, causing the job to be quite demanding. However, if teachers want to join this amazing educational reform, they have the power to change each of their students' lives, one growth mindset at a time.

**SOLVING THE ISSUE: LESSON PLANS**

To reconcile everything that I have talked about above, in this section I have developed a week of lesson plans that incorporate the effective teaching strategies and are mindful to the existing barriers to promote a growth mindset in students. My lesson plans are designed for 6th grade students that are in a geometry class. In my lessons I take a hands on approach to learning that focuses on self-discovery and critical thinking rather than lecture and repetition. At the end of the lesson plans I have included a detailed description of how I incorporate every strategy and am mindful of every barrier that I mentioned in the body of my thesis. This section is found in Appendix A.

## ASSUMPTION COLLEGE EDUCATION DEPARTMENT LESSON PLAN FORMAT

## Day 1

<b>Discipline/Subject:</b>	Math/Surface Area	<b>Grade level:</b>	6th
<b>Lesson Type:</b>	Full Class	<b>Approximate length of lesson:</b>	45 minutes

<b>Topic</b>	Calculating the Surface Area of Rectangular Prism
<b>Rationale</b>	In this lesson students will take a hands on approach to understanding how we can find the surface area of a rectangular prism without being forced to remember and plug into the surface area formula. It will push students and help them grow by allowing them to discover the formula on their own and connect what they are learning to real life applications.
<b>MA Curriculum Framework(s)</b>	<p><b>Geometry</b> <span style="float: right;"><b>6.G</b></span></p> <p><b>A. Solve real-world and mathematical problems involving area, surface area, and volume</b></p> <p>4. Represent three-dimensional figures using nets made up of rectangles and triangles and use the net to find the surface area of these figures. Apply these techniques in the context of solving real-world and mathematical problems.</p>
<b>Essential Question</b>	<ul style="list-style-type: none"> <li>● What is surface area?</li> <li>● How do you find the surface area of a rectangular prism?</li> <li>● Does the surface area formula that you developed</li> </ul>

	work for all rectangular prisms?
<b>Instructional Objective(s)</b>	<ul style="list-style-type: none"> <li>● Students will be able to identify that the surface area is found by adding up the area of all the faces of a rectangular prism.</li> <li>● Students will be able to develop the correct rectangular prism surface area formula on their own: <math>SA = 2lw + 2lh + 2hw</math></li> </ul>
<b>WIDA Standard(s)</b>	The Language of Math
<b>Language Domain(s)</b>	Writing
<b>Language Objective(s):</b>	<ul style="list-style-type: none"> <li>● A level 2 ELL student will be able to explain orally to a partner that to find the surface area of a rectangular prism you need to add up all of the areas of the faces using a word bank.</li> <li>● A level 4 ELL student will be able to provide a written explanation describing how they developed the surface area formula for rectangular prisms using a word wall.</li> </ul>
<b>Assessment Measure(s)</b>	<p><u>Informal:</u></p> <ul style="list-style-type: none"> <li>● Student Input/Observations: <ul style="list-style-type: none"> <li>○ Throughout the activity I will be asking a lot of questions and cold calling on students and taking volunteers. This will allow me to see what students understand the material and will help me judge the pace of my lessons to come later in the week. Some of the questions I will ask are: <ul style="list-style-type: none"> <li>■ What do you notice about the areas of the faces of the object?</li> <li>■ What is surface area?</li> </ul> </li> </ul> </li> </ul>

	<ul style="list-style-type: none"> <li>■ How did you discover that formula?</li> <li>■ How can we apply this method to other three-dimensional objects?</li> </ul> <p><u>Formal:</u></p> <ul style="list-style-type: none"> <li>● Time to Think Questions: <ul style="list-style-type: none"> <li>○ At the end of the lesson I am going to collect the “Time to Think” Questions and activity sheet that the students were working on during class. This will give me a clear understanding on where students are at with the material and will help me assess where I should go in tomorrow's lesson. I will grade the questions and activity as an effort grade and will provide feedback to clear up any misconceptions that students have. We will go over the questions as a class in tomorrow’s lesson.</li> </ul> </li> </ul>
<b>Materials</b>	<ul style="list-style-type: none"> <li>● Rectangular Prisms (children bring from home and I will have extras in class)</li> <li>● Paper</li> <li>● Pencil</li> <li>● Rulers</li> <li>● Scissors</li> <li>● Time to Think Questions</li> <li>● Activity Sheet</li> <li>● Extra Worksheet (review sheet)</li> <li>● Weekly Newsletter</li> </ul>
<b>Key Content Vocabulary</b>	<ul style="list-style-type: none"> <li>● <u>Rectangular Prism:</u> A solid (3-dimensional) object which has six faces that are rectangles</li> <li>● <u>Area:</u> The amount of space inside the boundary of a flat (2-dimensional) object</li> <li>● <u>Net:</u> A pattern that you can cut and fold to make a model of a solid shape</li> <li>● <u>Face:</u> Any of the individual flat surfaces of a solid</li> </ul>

	<p>object</p> <ul style="list-style-type: none"> <li>● <u>Surface Area</u>: The total area of the surface of a three-dimensional object</li> </ul>
<b>Procedure</b>	
<p><b>1. Initiation</b> (5 min)</p>	<ul style="list-style-type: none"> <li>● I will start the lesson by doing a quick warm up review game on area formulas as students will need to reference these throughout the activity. <ul style="list-style-type: none"> <li>○ I will put up all of the area formulas that students know on the board. Then I will call on two students who volunteer to go up to the board. Then I will call out a shape. The first student to touch the correct formula wins. I will do this until all of the formulas have gone through. I will not force any student to go to the board if they are not comfortable but will strongly encourage students to go up to the board and reward them with a piece of candy for their effort if they do go up to the board. The shapes that I will call out are rectangle, triangle, square, circle, trapezoid, and rhombus.</li> </ul> </li> </ul>
<p><b>2. Development</b> (35 minutes)</p>	<ul style="list-style-type: none"> <li>● I will start by explaining the activity that we will be doing in today's class. I asked each student to bring in a rectangular prism from home. I am assuming most students brought in an old snack box of some sort. I will have extras in the class if students forgot or did not have access to one at home. The point of having students bring one from home is that it allows me to show them that there is a connection to what they are learning and the real world.</li> <li>● I will write the directions to the activity on the board and say them verbally to ensure that all students know what they are supposed to be doing. <ul style="list-style-type: none"> <li>○ 1. Take out your rectangular prism.</li> <li>○ 2. Count and record how many faces your rectangular prism has.</li> </ul> </li> </ul>

	<ul style="list-style-type: none"> <li>○ 3. Cut out a piece of paper that covers each face of the rectangular prism.</li> <li>○ 4. Put all of the cut out paper faces together lying flat to see what the net of the rectangular prism looks like.</li> <li>○ 5. Draw a sketch of the net on your activity worksheet</li> <li>○ 6. Use a ruler to measure in inches each of the sides of your cut out paper and then label on both the cut out pieces and your sketch on the worksheet.</li> <li>○ 7. Based off your measurements and area formulas, find the area of each piece of paper you cut out and record the area on your activity worksheet.</li> <li>○ 8. Based on the areas you have calculated, determine what the total surface area of the rectangular prism is and record it on the activity worksheet.</li> <li>○ 9. Answer the “Time to Think” Questions and hand them in when you are done.</li> </ul>
<p><b>3. Closure</b> (5 min)</p>	<ul style="list-style-type: none"> <li>● To close the lesson, I will have the students continue working on the Time to Think questions and tell them if they do not finish them in class then they need to finish them for homework, but I am anticipating that the majority of students will finish in class. I will emphasize that I really want the students to think critically about their answers and about what was going on in their minds throughout the activity.</li> </ul>
<p><b>Meeting the Needs of Diverse Learners</b></p>	<ul style="list-style-type: none"> <li>● To meet the needs of diverse learners I am doing both individual and full class discussion and work to allow for all types of learners to benefit. Additionally, I will constantly be checking in with students and identifying misconceptions throughout the lesson.</li> <li>● For a student who has trouble with initiation, I have provided them with an activity sheet that will help guide them and keep them on track throughout the</li> </ul>

	<p>activity.</p> <ul style="list-style-type: none"> <li>● Other executive function problems can be addressed with the following accommodations and modifications:             <ul style="list-style-type: none"> <li>○ Accommodations:                 <ul style="list-style-type: none"> <li>■ Extended Time</li> <li>■ Immediate feedback</li> <li>■ Use of calculator</li> </ul> </li> <li>○ Modifications:                 <ul style="list-style-type: none"> <li>■ Less measuring when doing the activity</li> <li>■ Breaks between steps</li> </ul> </li> </ul> </li> </ul>
<p><b>Extension/ Back-up Activity</b></p>	<ul style="list-style-type: none"> <li>● If students finish the activity and Time to Think questions before the period is over then I have an additional worksheet that I will have the students work on. This worksheet will end up serving as a review sheet for the upcoming quiz and it will ask students to record the data they found in today's activity onto the worksheet.</li> </ul>

<p>Research-Based Best Practices</p>	<p><u>Classroom Environment:</u></p> <p>-I am having the students bring in rectangular prism from home which shows the students the real life application</p> <p><u>Praising Appropriately:</u></p> <p>-I will reward the students with candy for their effort of going up to the board and participating in the review game</p> <p><u>Promote Resilience</u></p> <p>-The Time to Think Questions are made to challenge and push students</p> <p><u>Multiple Representations</u></p> <p>-I do a hands on activity that allows students to discover the surface area formula on their own</p>
--------------------------------------	--



	<p><u>Incorporating Writing</u></p> <p>-The Time to Think questions are open ended questions that allow the students to write</p> <p><u>Financial Restrictions</u></p> <p>-This is a pencil and paper based lesson</p> <p><u>Student Accountability</u></p> <p>-The Time to Think questions are graded for effort</p> <p><u>Parental Accountability</u></p> <p>-I will send out a weekly newsletter to parents to inform them of what is going on this week</p> <p><u>State Testing</u></p> <p>-The students will come up with the formulas on their own so they will have a deeper understanding that requires less repetition and practice and allow them to apply this on the state test</p>
--	---

# WEEKLY NEWSLETTER

“STRIVE FOR PROGRESS NOT PERFECTION”



Sun	Mon	Tues	Wed	Thur	Fri	Sat
		<u>1</u>	<u>2</u>	<u>3</u>	<u>4</u>	<u>5</u>
<u>6</u>	<u>7</u>	<u>8</u>	<u>9</u>	<u>10</u>	<u>11</u>	<u>12</u>
<u>13</u>	<u>14</u>	<u>15</u>	<u>16</u>	<u>17</u>	<u>18</u>	<u>19</u>
<u>20</u>	<u>21</u>	<u>22</u>	<u>23</u>	<u>24</u>	<u>25</u>	<u>26</u>
<u>27</u>	<u>28</u>	<u>29</u>	<u>30</u>	<u>31</u>		



What is happening this week?	Upcoming tests/quizzes:
<p><b>-Mon: Surface Area of rectangular prisms</b></p> <p><b>-Tues: Surface Area of cylinders</b></p> <p><b>-Wed: Surface Area of pyramids</b></p> <p><b>-Thurs: Surface Area of cones</b></p> <p><b>-Fri: Quiz, introduction to volume, &amp; a surprise for students</b></p>	<p><b>-Quiz on Friday that covers:</b></p> <p><b>Surface area of:</b></p> <ul style="list-style-type: none"> <li><b>-rectangular prisms</b></li> <li><b>-cylinder</b></li> <li><b>-pyramid</b></li> <li><b>-cone</b></li> </ul>

**Attention Parents:**

**\*\*Reminder that on Halloween (10/31) Students are allowed to dress up for school as long as the costume is appropriate and adheres to school guidelines\*\***

**\*\*Remind your child to start thinking about what 3-dimensional object they want to use for their upcoming project\*\***

Name: \_\_\_\_\_

Date: \_\_\_\_\_

## Surface Area of Rectangular Prisms Activity

Part 1: Count the number of faces the rectangular prism has.

# of Faces: \_\_\_\_\_

Part 2: Lay your cut out pieces of paper together and draw a picture to represent the net of the rectangular prism.

Part 3: Using the inches side of the ruler, measure the sides of the faces and label them on your drawing.

Part 4: Using the formulas we reviewed in the beginning of class and the measurements you recorded, find the area of each face of the prism.

Area: \_\_\_\_\_

Area: \_\_\_\_\_

Area: \_\_\_\_\_

Area: \_\_\_\_\_

Area: \_\_\_\_\_

Area: \_\_\_\_\_

Part 5: Find the total surface area of the rectangular prism (use your knowledge of everything you have learned in this activity).

Surface Area: \_\_\_\_\_

Name: \_\_\_\_\_

Date: \_\_\_\_\_

## Time to Think Questions

1. Explain in your own words what surface area means.

---

---

---

2. How can you find the surface area of a rectangular prism?

---

---

---

3. Based on what you learned in the activity, develop a formula for finding the surface area of a rectangular prism.

---

---

---

4. Do you think that your formula will work for other rectangular prisms? Why or why not?

---

---

---

5. Apply your formula to this problem. Does it work?

Catherine needs to wrap a birthday present for her friend, but she does not know how much wrapping paper she needs to buy. The box she is wrapping is the following dimensions: 5 inches x 10 inches x and 7 inches. How much wrapping paper will Catherine need to buy?

---

---

---

Name: \_\_\_\_\_

Date: \_\_\_\_\_

**Review for Quiz on Surface Area:**

## ❖ Rectangular Prism:

➤ Surface Area Formula: \_\_\_\_\_

- Ex.) Find the surface area of a box with the following dimensions: 6 inches x 4 inches x 5 inches. Show your work!

## ASSUMPTION COLLEGE EDUCATION DEPARTMENT LESSON PLAN FORMAT

## Day 2

<b>Discipline/Subject:</b>	Math/Surface Area	<b>Grade level:</b>	6th
<b>Lesson Type:</b>	Full Class	<b>Approximate length of lesson:</b>	50 minutes

<b>Topic</b>	Surface Area of a Cylinder
<b>Rationale</b>	In this lesson students will take a hands on approach to understanding how we can find the surface area of a cylinder without being forced to remember and plug into the surface area formula. It will push students and help them grow by allowing them to communicate with a partner and discover the formula on their own and make real life connections to everyday objects.
<b>MA Curriculum Framework(s)</b>	<p><b>Geometry</b> <span style="float: right;"><b>6.G</b></span></p> <p><b>A. Solve real-world and mathematical problems involving area, surface area, and volume</b></p> <p>4. Represent three-dimensional figures using nets made up of rectangles and triangles and use the net to find the surface area of these figures. Apply these techniques in the context of solving real-world and mathematical problems.</p>
<b>Essential Question</b>	<ul style="list-style-type: none"> <li>● What is surface area?</li> <li>● How do you find the surface area of a cylinder?</li> <li>● Does the surface area formula that you developed</li> </ul>

	<p>work for all cylinders?</p> <ul style="list-style-type: none"> <li>• How is the surface area of a cylinder similar or different then the surface area of a rectangular prism?</li> </ul>
<b>Instructional Objective(s)</b>	<ul style="list-style-type: none"> <li>• Students will be able to identify that the bases of the cylinder are circles and that the side is a rectangle.</li> <li>• Students will be able to discover that the surface area is found by adding up the area all the faces of the cylinder.</li> <li>• Students will be able to develop the correct cylinder surface area formula on their own: <math>SA = 2\pi r h + 2\pi r^2</math> and apply it to solve problems.</li> </ul>
<b>WIDA Standard(s)</b>	The Language of Math
<b>Language Domain(s)</b>	Speaking and Writing
<b>Language Objective(s):</b>	<ul style="list-style-type: none"> <li>• A level 2 ELL student will be able to explain orally to a partner that to find the surface area of a cylinder you need to find the area of both bases and add it to the area of the side using a sentence frame.</li> <li>• A level 4 ELL student will be able to provide a written explanation describing how they developed the surface area formula for a cylinder using a word bank.</li> </ul>
<b>Assessment Measure(s)</b>	<p><u>Informal:</u></p> <ul style="list-style-type: none"> <li>• Student Input/Observations/Time to Think Questions: <ul style="list-style-type: none"> <li>○ Throughout the activity I will be asking a lot of questions and cold calling on students and taking volunteers. This will allow me to see what students understand the material and will help me judge the pace of my lessons to come later in the week. Some of the</li> </ul> </li> </ul>



	<p>questions I will ask are:</p> <ul style="list-style-type: none"> <li>■ What do you notice about the areas of the faces of the object?</li> <li>■ Are the faces of a cylinder different shapes?</li> <li>■ What is surface area?</li> <li>■ How did you discover that formula?</li> <li>■ How can we apply this method to other three dimensional objects?</li> <li>■ How is your formula similar or different to the one you developed on rectangular prisms?</li> </ul> <p><u>Formal:</u></p> <ul style="list-style-type: none"> <li>● Growth Mindset Exit Ticket: <ul style="list-style-type: none"> <li>○ At the end of the lesson I am going to give the students a growth mindset exit ticket. The exit ticket will ask them a series of questions such as what is something you struggled with? Are you still struggling with this? What can you do to better to strengthen your knowledge of this? The exit ticket is attached. I will be grading this as a participation grade and as a way for me to better adapt my lessons to fit the needs of all my students and to identify any misconceptions that need to be addressed in future lessons.</li> </ul> </li> </ul>
<p><b>Materials</b></p>	<ul style="list-style-type: none"> <li>● Pencil</li> <li>● Scissors</li> <li>● Construction Paper</li> <li>● Cylinders</li> <li>● Rulers</li> <li>● Activity Worksheet</li> <li>● Time to Think Questions</li> </ul>

	<ul style="list-style-type: none"> <li>● Growth Mindset Exit Ticket</li> </ul>
<b>Key Content Vocabulary</b>	<ul style="list-style-type: none"> <li>● <u>Cylinder</u>: two identical flat ends that are circular or elliptical and one curved side</li> <li>● <u>Net</u>: A pattern that you can cut and fold to make a model of a solid shape</li> <li>● <u>Face</u>: Any of the individual flat surfaces of a solid object</li> <li>● <u>Surface Area</u>: The total area of the surface of a three-dimensional object</li> </ul>
<b>Procedure</b>	
<p><i>1. Initiation</i> (10 min)</p>	<ul style="list-style-type: none"> <li>● To get the lesson started I am going to activate past knowledge by going over the Time to Think Questions from yesterday's Lesson. I will hand back the questions to each of the students. There will feedback on the students' answers and I will have starred a few students' responses for each question that I want to share with the class. I will call on students with both correct and incorrect solutions because I want to clear up misconceptions that students may have had and show students that making mistakes are good because we can learn from them and grow in upcoming lessons.</li> </ul>
<p><i>2. Development</i> (35 minutes)</p>	<ul style="list-style-type: none"> <li>● Then I will explain to the students that today we are going to be doing a similar activity to yesterday but today will be with cylinders and students will be able to work with a partner. I will strategically place students in partners ahead of time to make sure that the students are matched with someone with the same mathematics skills as them. This will ensure that one student is not doing all the work while the other is just sitting there. I will put the directions on the board again, but I will not go over them because they are very similar to yesterday. The students will be measuring a cylinder object today and following the same procedure as yesterday. However, I will point out that I want the students to answer the Time to Think questions on</li> </ul>

	<p>their own rather than working with their partner, so I am able to identify each student's thought process and understanding.</p> <ul style="list-style-type: none"> <li>● Throughout the activity I will be walking around and monitoring the partner work. If partners come across something they find interesting or make a mistake I will choose to share things with the entire class if I feel they will benefit from it.</li> <li>● Students will answer the Time to Think Questions on their own and if they finish early, they should share their answers with their partner.</li> </ul>
<p><b>3. Closure</b> (5 min)</p>	<ul style="list-style-type: none"> <li>● When there are five minutes left in the period, I will hand out an exit ticket to determine what the students took away from the lesson individually. The students will hand in the exit ticket as they leave the classroom. The exit ticket will promote a growth mindset as it will have students answer a series of questions. Some of the questions will ask students where they feel they are at, how hard they feel they have worked, and what can they do to increase their knowledge in future lessons. The exit ticket will be attached.</li> </ul>
<p><b>Meeting the Needs of Diverse Learners</b></p>	<ul style="list-style-type: none"> <li>● To meet the needs of diverse learners I am doing individual, partner, and full class discussion and work to allow for all types of learners to benefit. Additionally, I will constantly be checking in with students and partners making sure that I am clearing up any mistakes or misconceptions students may have.</li> <li>● For a student who has trouble with staying on task, I have provided them with partners so the partner can help encourage the other partner to get started and stay focused throughout the activity. I was cautious when placing students with partners as not only I insured that students were not just sitting with their friends, but I also made sure that students who struggle with certain executive function skills were placed with students who did not have those same problems and could therefore help guide the other student.</li> <li>● Other executive function problems can be addressed</li> </ul>

	<p>with the following accommodations and modifications:</p> <ul style="list-style-type: none"> <li>○ Accommodations:             <ul style="list-style-type: none"> <li>■ Extended Time</li> <li>■ Immediate feedback</li> <li>■ Use of calculator</li> </ul> </li> <li>○ Modifications:             <ul style="list-style-type: none"> <li>■ Less responsibilities when doing the partner work</li> <li>■ Breaks between tasks</li> </ul> </li> </ul>
<p><b>Extension/ Back-up Activity</b></p>	<ul style="list-style-type: none"> <li>● If students finish the activity and Time to Think questions early, then they can share and compare their answers to their partner. If they still have extra time, then I will have them complete the cylinder section of the surface area review sheet for the upcoming quiz.</li> </ul>

<p>Research-Based Best Practices</p>	<p><u>Classroom Environment:</u></p> <p>-There will be word walls and posters on the walls to help guide students</p> <p><u>Encouraging mistakes</u></p> <p>-I will have students share their mistakes that they make so the class can grow and learn from them</p> <p><u>Going over homework correctly</u></p> <p>-I will go over both incorrect and correct solutions to encourage mistakes and identify common misconceptions</p> <p><u>Promote Resilience</u></p> <p>-I will have the students do an exit ticket that will serve as a check in for students and let me know how comfortable/uncomfortable they feel with the content</p> <p><u>Modify Problems</u></p> <p>-I will strategically place students with partners with the same math ability as them</p>
--------------------------------------	---

	<p><u>Multiple Representations</u></p> <p>-I use multiple representations of pyramids</p> <p><u>Incorporating Writing</u></p> <p>-Open ended Time to Think Questions</p> <p><u>Class Length</u></p> <p>-This lesson can be combined with Day 1's lesson and be done in a longer class period time if that is what the school district has</p> <p><u>Financial Restrictions</u></p> <p>-This lesson is done with pencil and paper</p> <p><u>Student Accountability</u></p> <p>-The students need to contribute to partner discussion</p> <p><u>Class Size</u></p> <p>-I am using partners to break up the class (I can check in with each set of partners)</p>
--	---

Name: \_\_\_\_\_

Date: \_\_\_\_\_

Partners Name: \_\_\_\_\_

## Surface Area of Cylinders Activity

Part 1: Count the number of faces the cylinder has.

# of Faces: \_\_\_\_\_

Part 2: Put together your cut out pieces of paper and draw a picture to represent the net of the cylinder.

Part 3: Using the inches side of the ruler, measure the sides of the faces and record on your drawing.

Part 4: Using the formulas we reviewed in the beginning of class and the measurements you recorded find the area of each face of the cylinder.

Area: \_\_\_\_\_

Area: \_\_\_\_\_

Area: \_\_\_\_\_

Part 5: Find the total surface area of the cylinder (use your knowledge of anything you learned in this activity).

Surface Area: \_\_\_\_\_

Name: \_\_\_\_\_

Date: \_\_\_\_\_

## Time to Think Questions

Explain in your own words what surface area means.

---

---

---

How can you find the surface area of a cylinder?

---

---

---

Based on what you learned in the activity, develop a formula for finding the surface area of a cylinder.

---

---

---

Apply your formula to this problem, does it work?

Find the surface area of the cylinder.

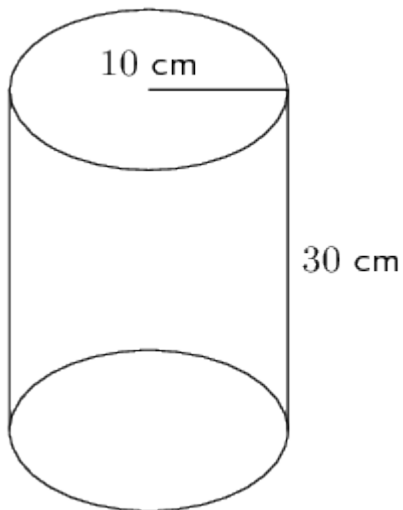

---



Name: \_\_\_\_\_

Date: \_\_\_\_\_

**Review for Quiz on Surface Area:**

## ❖ Rectangular Prism:

➤ Surface Area Formula: \_\_\_\_\_

- Ex.) Find the surface area of a box with the following dimensions: 6 inches x 4 inches x 5 inches. Show your work!

## ❖ Cylinder:

➤ Surface Area Formula: \_\_\_\_\_

- Ex.) Find the surface area of a cylinder with a radius of 2 inches and a height of 4 inches. Show your work!

Name: \_\_\_\_\_

Date: \_\_\_\_\_

Growth Mindset Exit Ticket

1. What is something you struggled with in this activity?

---

---

2. What is something that came easy to you in this activity?

---

---

3. What did you learn?

---

---

4. Rate your work ethic during this activity (5 being the highest).

1                      2                      3                      4                      5

## ASSUMPTION COLLEGE EDUCATION DEPARTMENT LESSON PLAN FORMAT

## Day 3

<b>Discipline/Subject:</b>	Math/Surface Area	<b>Grade level:</b>	6th
<b>Lesson Type:</b>	Full Class	<b>Approximate length of lesson:</b>	45 minutes

<b>Topic</b>	Surface Area of a Pyramid
<b>Rationale</b>	In this lesson students will build on their understanding of surface area by doing a hands on activity with pyramids. In this activity students will be using the previous day's lessons and apply that knowledge to try to discover the surface area formula for pyramids on their own.
<b>MA Curriculum Framework(s)</b>	<p><b>Geometry</b> <span style="float: right;"><b>6.G</b></span></p> <p><b>A. Solve real-world and mathematical problems involving area, surface area, and volume</b></p> <p>4. Represent three-dimensional figures using nets made up of rectangles and triangles and use the net to find the surface area of these figures. Apply these techniques in the context of solving real-world and mathematical problems.</p>
<b>Essential Question</b>	<ul style="list-style-type: none"> <li>● What is surface area?</li> <li>● How do you find the surface area of a pyramid?</li> <li>● Does the surface area formula that you developed work for all pyramids?</li> <li>● How is the surface area of a pyramid similar or</li> </ul>

	different to the previous three dimensional shapes we have worked with?
<b>Instructional Objective(s)</b>	<ul style="list-style-type: none"> <li>● Students will be able to identify that the base of the pyramid is a square or rectangle and the sides are triangles.</li> <li>● Students will be able to discover that the surface area is found by adding up the area all the faces of the pyramid.</li> <li>● Students will be able to develop the correct pyramid surface area formula on their own: <math>SA = 2bs + b^2</math> and apply it to solve problems.</li> </ul>
<b>WIDA Standard(s)</b>	The Language of Math
<b>Language Domain(s)</b>	Speaking and Listening
<b>Language Objective(s):</b>	<ul style="list-style-type: none"> <li>● A level 2 ELL student will be able to explain orally in English to a partner that to find the surface area of a pyramid you need to find the area of a base and add it to the area of each of the sides using a word bank.</li> <li>● A level 4 ELL student will be able to provide a written explanation describing how they developed the surface area formula for a pyramid using a sentence starter.</li> </ul>
<b>Assessment Measure(s)</b>	<u>Informal:</u> <ul style="list-style-type: none"> <li>● Student Input/Observations: <ul style="list-style-type: none"> <li>○ Throughout the activity I will be asking a lot of questions and cold calling on students and taking volunteers. This will allow me to see what students understand the material and will help me judge the pace of my lessons to come later in the week. Some of the questions I will ask are:</li> </ul> </li> </ul>

	<ul style="list-style-type: none"> <li>■ What do you notice about the areas of the faces of the object?</li> <li>■ Are the faces of a pyramid different shapes?</li> <li>■ What is the surface area?</li> <li>■ How did you discover that formula?</li> <li>■ How can we apply this method to other three dimensional objects?</li> <li>■ How is your formula similar or different to the one you developed for other three dimensional objects?</li> </ul> <p><u>Formal:</u></p> <ul style="list-style-type: none"> <li>● Time to Think Questions Discussion: <ul style="list-style-type: none"> <li>○ At the end of the lesson I am going to have the students break into groups and discuss the answers to their questions. I will be actively walking around during this time and taking notes to assess each student's understanding. Additionally, I will be collecting the Time to Think Questions to give students individual feedback.</li> </ul> </li> </ul>
<b>Materials</b>	<ul style="list-style-type: none"> <li>● Scissors</li> <li>● Tape</li> <li>● Cut out worksheets</li> <li>● Activity worksheet</li> <li>● Ruler</li> <li>● Time to Think Questions</li> <li>● Extra activity worksheets</li> </ul>
<b>Key Content Vocabulary</b>	<ul style="list-style-type: none"> <li>● <u>Pyramid:</u> A solid object where the sides are triangles which meet at the top and the base is a polygon.</li> <li>● <u>Net:</u> A pattern that you can cut and fold to make a model of a solid shape.</li> </ul>

	<ul style="list-style-type: none"> <li>● <u>Face</u>: Any of the individual flat surfaces of a solid object.</li> <li>● <u>Surface Area</u>: The total area of the surface of a three-dimensional object.</li> </ul>
<b>Procedure</b>	
<p><b>1. Initiation</b> (5 min)</p>	<ul style="list-style-type: none"> <li>● To start the lesson, I am going to give the students a warm up slip that has them solving a surface area problem with a cylinder. We will go over the warm up slip once the students are done working on it. I will be asking for volunteers during this time and praising students for their work ethic and effort rather than their intelligence level. The warm up slip will be attached.</li> </ul>
<p><b>2. Development</b> (30 minutes)</p>	<ul style="list-style-type: none"> <li>● I will start by going over today's activity. I will tell students that I want them to work on the activity part on their own. I will put the directions on the board and call on students to read the directions out loud. <ul style="list-style-type: none"> <li>○ 1. Cut out the pyramid</li> <li>○ 2. Write on your activity worksheet how you think you would find the surface area of a pyramid.</li> <li>○ 3. Use a ruler to measure the base and sides of each face. Record this on your cut out.</li> <li>○ 4. Fold the pyramid into a three dimensional shape and tape it together.</li> <li>○ 5. Find the area of each face.</li> <li>○ 6. Find the surface area of the pyramid.</li> <li>○ 7. Write down a formula that you developed to find the surface area of a pyramid.</li> <li>○ 8. Answer the Time to Think questions individually.</li> </ul> </li> <li>● I will be walking around and assisting students with questions and helping aid them in the right direction</li> </ul>

	<p>if they are struggling. If multiple students are getting stuck on the same things, then I will stop everyone and go over the common misconceptions to make sure everyone is back on the right track.</p>
<p><b>3. Closure</b> (10 min)</p>	<ul style="list-style-type: none"> <li>● To end the lesson, we will be having group discussions. I will put everyone in groups of four and the students will be going around and sharing their answers to their Time to Think Questions. If students do not feel comfortable sharing in front of their peers, they do not have to. However, I will reward students with a piece of candy if they work hard and do share their answers as a way to praise them for their effort. Sharing in a group will allow other students to hear each other's critical thought process and will hopefully help students enhance their own understanding. For homework I will have the students complete the pyramid section of their surface area quiz review sheet.</li> </ul>
<p><b>Meeting the Needs of Diverse Learners</b></p>	<ul style="list-style-type: none"> <li>● To meet the needs of diverse learners I am doing individual, group, and full class discussion and work to allow for all types of learners to benefit. Additionally, I will constantly be checking in with students and identifying misconceptions throughout the lesson.</li> <li>● For a student who has a slow processing speed I can provide them with an activity sheet that is more guided with fill in the blanks to ensure they are staying on track and not losing focus.</li> <li>● Other executive function problems can be addressed with the following accommodations and modifications:             <ul style="list-style-type: none"> <li>○ Accommodations:                 <ul style="list-style-type: none"> <li>■ Extended Time</li> <li>■ Immediate feedback</li> <li>■ Use of calculator</li> </ul> </li> <li>○ Modifications:                 <ul style="list-style-type: none"> <li>■ Measurements already given</li> </ul> </li> </ul> </li> </ul>

	<ul style="list-style-type: none"> <li>■ Breaks between tasks</li> </ul>
<p><b>Extension/ Back-up Activity</b></p>	<ul style="list-style-type: none"> <li>● If students finish the activity early, I will have them start early on their homework, which is to complete the pyramid section of the surface area review sheet. If students still finish that early, then I will have a backup worksheet that students can complete that has surface area problems involving pyramids.</li> </ul>

<p>Research-Based Best Practices</p>	<p><u>Classroom Environment:</u></p> <p>-I am doing a warm up slip with the students to get their brains thinking</p> <p><u>Praising Appropriately</u></p> <p>-I will praise students for their hard work ethic and reward them with candy if they share their answer during the group discussion</p> <p><u>Encouraging mistakes</u></p> <p>-If multiple students are stuck on the same thing, I will go over the common misconception as a class</p> <p><u>Promote Resilience</u></p> <p>-I allow the student to self-discovery the formulas by doing a hands on activity that allows students to understand the process</p> <p><u>Incorporating Writing</u></p> <p>-Time to Think Questions</p> <p><u>Financial Restrictions</u></p> <p>-My lesson is pencil and paper based</p> <p><u>State Testing</u></p> <p>-The process of self-discovering the formulas will help the students remember the process come time for state tests</p>
--------------------------------------	---



Name: \_\_\_\_\_

Date: \_\_\_\_\_

**Warm Up Slip:**

Find the surface area of the Cylinder. Show your work!

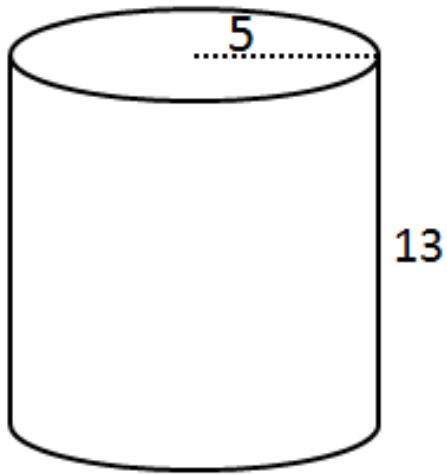

Surface Area: \_\_\_\_\_

Name: \_\_\_\_\_

Date: \_\_\_\_\_

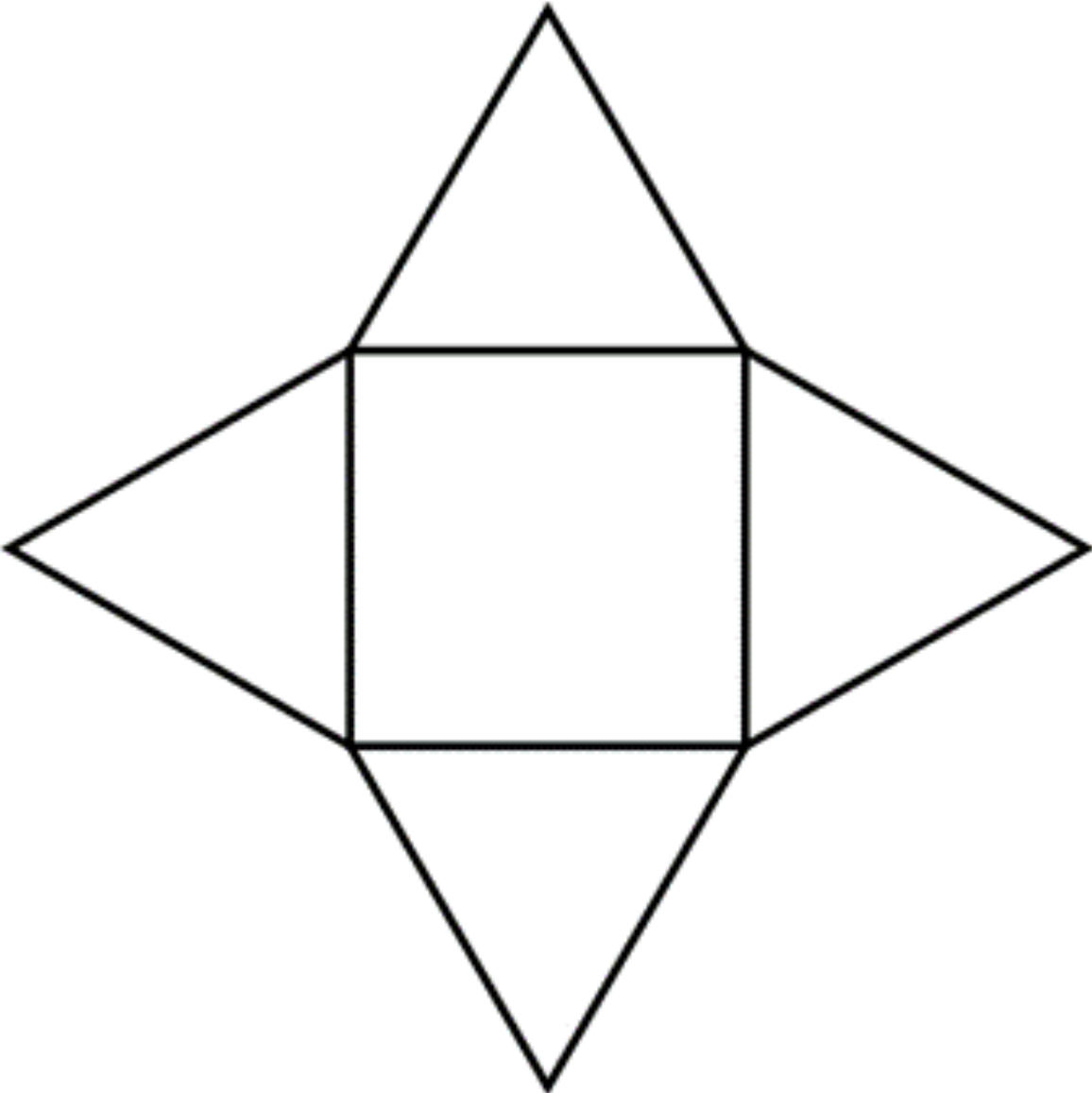

Name: \_\_\_\_\_

Date: \_\_\_\_\_

**Surface Area of Pyramids Activity**

Brainstorm how you think you can find the surface area of a pyramid:

---

---

---

Find the area of each face:

Base: \_\_\_\_\_

Side: \_\_\_\_\_

Side: \_\_\_\_\_

Side: \_\_\_\_\_

Side: \_\_\_\_\_

Total Surface Area of the Pyramid: \_\_\_\_\_

Based on the measurements and areas you calculated, develop a formula that you can use to calculate the surface area of a pyramid:

---

Name: \_\_\_\_\_

Date: \_\_\_\_\_

**Time to Think Questions for Pyramids**

Give a real life example of a pyramid.

---

---

---

What is the difference between a pyramid and a triangular prism?

---

---

---

Solve for the following square based pyramid.

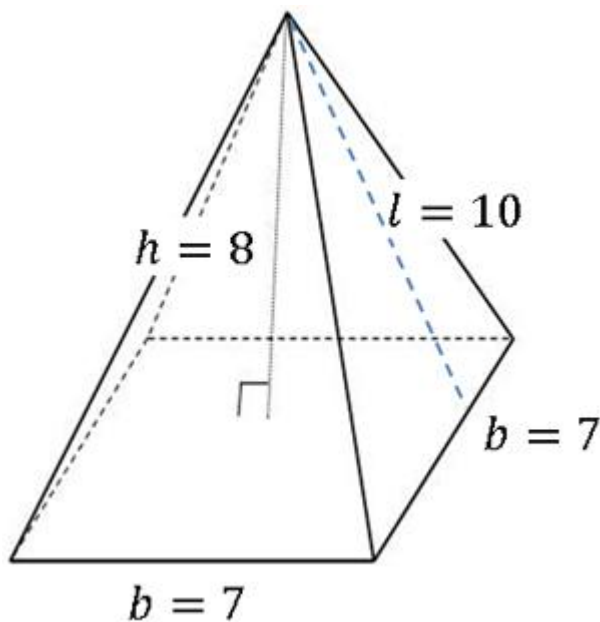

Surface Area: \_\_\_\_\_

Name: \_\_\_\_\_

Date: \_\_\_\_\_

**Review for Quiz on Surface Area:**

## ❖ Rectangular Prism:

➤ Surface Area Formula: \_\_\_\_\_

- Ex.) Find the surface area of a box with the following dimensions: 6 inches x 4 inches x 5 inches. Show your work!

## ❖ Cylinder:

➤ Surface Area Formula: \_\_\_\_\_

- Ex.) Find the surface area of a cylinder with a radius of 2 inches and a height of 4 inches. Show your work!

## ❖ Pyramid:

➤ Surface Area Formula: \_\_\_\_\_

- Ex.) Find the surface area of a pyramid with a square base that has a side of 4 inches and a triangular side that is 5 inches tall. Show your work!

## ASSUMPTION COLLEGE EDUCATION DEPARTMENT LESSON PLAN FORMAT

## Day 4

<b>Discipline/Subject:</b>	Math/Surface Area	<b>Grade level:</b>	6th
<b>Lesson Type:</b>	Full Class	<b>Approximate length of lesson:</b>	45 minutes

<b>Topic</b>	Surface Area of a Cone
<b>Rationale</b>	This lesson will be the final lesson on surface area before tomorrow's quiz. Students will be doing a hands on activity to develop an understanding of the surface area of a cone. This activity will be similar to the activity on pyramids. It will allow students to connect their previous knowledge of surface area with the new knowledge they learn on cones.
<b>MA Curriculum Framework(s)</b>	<p><b>Geometry</b> <span style="float: right;"><b>6.G</b></span></p> <p><b>A. Solve real-world and mathematical problems involving area, surface area, and volume</b></p> <p>4. Represent three-dimensional figures using nets made up of rectangles and triangles and use the net to find the surface area of these figures. Apply these techniques in the context of solving real-world and mathematical problems.</p>
<b>Essential Question</b>	<ul style="list-style-type: none"> <li>● What is surface area?</li> <li>● How do you find the surface area of a cone?</li> </ul>

	<ul style="list-style-type: none"> <li>• Does the surface area formula that you developed work for all cones?</li> <li>• How is the surface area of a cone similar or different to the previous 3-dimensional shapes we have worked with?</li> </ul>
<b>Instructional Objective(s)</b>	<ul style="list-style-type: none"> <li>• Students will be able to identify that the base of the cone is a circle.</li> <li>• Students will be able to discover that the surface area is found by adding up the area of all the faces of the cone.</li> <li>• Students will be able to develop the correct cone surface area formula on their own: <math>SA = \pi rs + \pi r^2</math> formula and apply it to solve problems.</li> </ul>
<b>WIDA Standard(s)</b>	The Language of Math
<b>Language Domain(s)</b>	Speaking, Listening, Reading, and Writing
<b>Language Objective(s):</b>	<ul style="list-style-type: none"> <li>• A level 2 ELL student will be able to explain in writing that you need to find the area of the faces to find the total surface area of the cone using a word wall.</li> <li>• A level 4 ELL student will be able to provide an oral explanation describing how to find the surface area of a cone based on what they discovered during the activity using guided notes.</li> </ul>
<b>Assessment Measure(s)</b>	<u>Informal:</u> <ul style="list-style-type: none"> <li>• Student Input/Observations/Time to Think Questions: <ul style="list-style-type: none"> <li>○ Throughout the activity I will be asking a lot of questions and cold calling on students and taking volunteers. Additionally, I will have students provide written explanations to critical thinking questions. This will allow</li> </ul> </li> </ul>

	<p>me to see what students understand the material and will help me judge the pace of my lesson. Some of the questions I will ask are:</p> <ul style="list-style-type: none"> <li>■ What do you notice about the areas of the faces of the object?</li> <li>■ Are the faces of a cone different shapes?</li> <li>■ What is surface area?</li> <li>■ How did you discover the surface area formula?</li> <li>■ How can we apply this method to other three-dimensional objects?</li> <li>■ How is your formula similar or different to the one you develop on other three dimensional objects?</li> </ul> <p><u>Formal:</u></p> <ul style="list-style-type: none"> <li>● Jeopardy Game:             <ul style="list-style-type: none"> <li>○ At the end of the lesson I am going to play a Jeopardy game with the students. The game will serve as a review session for all the 3-dimensional shapes that we have covered for this week in preparation for tomorrow's quiz. I am going to have every student write down the answers to each Jeopardy question in their notebook. Students will have the chance to earn an extra credit point on tomorrow's quiz if they volunteer to share their answers with the class. I am running the game this way because I feel students will benefit more if they answer the questions on their own rather than allowing one person to lead the team. This way students will be able to identify what they need to study tonight.</li> </ul> </li> </ul>
<p><b>Materials</b></p>	<ul style="list-style-type: none"> <li>● Jeopardy game</li> </ul>



	<ul style="list-style-type: none"> <li>● Activity Worksheet</li> <li>● Time to Think questions</li> <li>● Surface Area Review sheet</li> <li>● Cut out sheet</li> <li>● Pencil</li> </ul>
<b>Key Content Vocabulary</b>	<ul style="list-style-type: none"> <li>● <u>Cone</u>: A solid (3-dimensional) object that has a circular base joined to point by a curved side.</li> <li>● <u>Net</u>: A pattern that you can cut and fold to make a model of a solid shape.</li> <li>● <u>Face</u>: Any of the individual flat surfaces of a solid object.</li> <li>● <u>Surface Area</u>: The total area of the surface of a three-dimensional object.</li> </ul>
<b>Procedure</b>	
<p><b>1. Initiation</b> (0 minutes)</p>	<ul style="list-style-type: none"> <li>● I will not do a warm up for today's lesson because I want to maximize the students time on today's activity and the review jeopardy game I have planned. When the students come in there will be directions on the board letting them know what to do during the activity.</li> </ul>
<p><b>2. Development</b> (20 minutes)</p>	<ul style="list-style-type: none"> <li>● To keep up with the routine and pattern of the week, today's lesson will be very similar to yesterday's lesson but today we will be working with cones. Students will have a similar activity sheet as yesterday and the directions will be put on the board. I am giving students the option to work with a partner of their choice today but I will warn the students that if they are not actively engaged and working on the activity then I will separate them and they will not be given an opportunity to earn bonus points later in the class during the Jeopardy game. The directions on the board will be: <ul style="list-style-type: none"> <li>○ 1. Cut out the cone</li> </ul> </li> </ul>

	<ul style="list-style-type: none"> <li>○ 2. Write on your activity worksheet how you think you would find the surface area of a cone.</li> <li>○ 3. Use a ruler to measure the base and sides. Record this on your cut out.</li> <li>○ 4. Fold the cone into a 3-dimensional shape and tape it together.</li> <li>○ 5. Find the area of each face.</li> <li>○ 6. Find the surface area of the cone.</li> <li>○ 7. Write down a formula that you developed to find the surface area of a cone.</li> <li>○ 8. Answer the Time to Think questions individually or with a partner.</li> </ul> <ul style="list-style-type: none"> <li>● If students finish early, I will have them fill in the final part of their surface area review sheet on cones. Otherwise this will be assigned for homework.</li> </ul>
<p><b>3. Closure</b> (15 minutes)</p>	<ul style="list-style-type: none"> <li>● To close the lesson, we will be doing a Jeopardy Review game on surface Area. The jeopardy board will have each of the four 3-dimensional shapes that we covered this week. It will go over formulas, shapes, and involve critical thinking questions. I will use this review game as a way for students to identify where they are at and what they need to study before the quiz that they will have in class first thing tomorrow. The jeopardy game will be electronic and available to students so they can play it and review at home on their own as well. Additionally, as a way to praise students for their hard work they will have a chance to earn extra credit points on tomorrow's quiz if they raise their hand to answer one of the questions in front of the class. I am not using teams for this game because I find that when I use teams, one person tends to take over and the rest of the team just follows in their shadow. Since the purpose of this game is to allow students to identify where they are at content wise, I think it is best that students should answer the questions on their own.</li> </ul>

<p><b>Meeting the Needs of Diverse Learners</b></p>	<ul style="list-style-type: none"> <li>● To meet the needs of diverse learners I am doing individual, partner, and full class discussion and work to allow for all types of learners to benefit. Additionally, I will constantly be checking in with students and identifying misconceptions throughout the lesson.</li> <li>● For a student who has a poor time with organization I have provided the students with a study guide worksheet for the quiz tomorrow on surface area. On this review sheet they can find the surface area formulas and examples for each of the four 3-dimensional objects that we covered this week. Additionally, for students that I know really struggle with organization I will check in with them to make sure that all the papers and materials from this week are in a safe and organized place. This will help the students when it comes time to study for tomorrow’s quiz.</li> <li>● Other executive function problems can be addressed with the following accommodations and modifications:             <ul style="list-style-type: none"> <li>○ Accommodations:                 <ul style="list-style-type: none"> <li>■ Extended Time</li> <li>■ Immediate feedback</li> <li>■ Use of calculator</li> </ul> </li> <li>○ Modifications:                 <ul style="list-style-type: none"> <li>■ Breaks between tasks and Jeopardy questions</li> </ul> </li> </ul> </li> </ul>
<p><b>Extension/ Back-up Activity</b></p>	<ul style="list-style-type: none"> <li>● If the students finish the activity worksheet early, I will have them fill in the final part of the surface area review sheet and have them start to review and look over the sheet in preparation to study for tomorrow’s quiz.</li> </ul>

<p>Research-Based Best Practices</p>	<p><u>Classroom Environment:</u>          -There will be a word wall and posters to help students who struggle with the vocabulary</p>
--------------------------------------	--

	<p><u>Praising Appropriately</u></p> <p>-I will reward students with bonus points if they raise their hand an answer a question during the jeopardy review game</p> <p><u>Going over homework correctly</u></p> <p>-The correct solutions to the review sheet will be on line and accessible to the students</p> <p><u>Modify Problems</u></p> <p>-The Jeopardy game will range in difficulty of problems</p> <p><u>Multiple Representations</u></p> <p>-Jeopardy Game</p> <p><u>Class Length</u></p> <p>-This lesson is very similar to Day 3 and these two lessons can be combined to a longer period length lesson if that is what the school district has</p> <p><u>Financial Restrictions</u></p> <p>-The jeopardy game can be done with pencil and paper, I just chose to do it electronically</p> <p><u>Student Accountability</u></p> <p>-Students will have to be accountable when working with partners</p> <p><u>Student Behavior</u></p> <p>-Since I let the students pick their partners, if they are not behaving well, I will remove them from the partner and make them work on their own</p> <p><u>Class Size</u></p> <p>-I put the students in partners to break up the class</p>
--	---

Name: \_\_\_\_\_

Date: \_\_\_\_\_

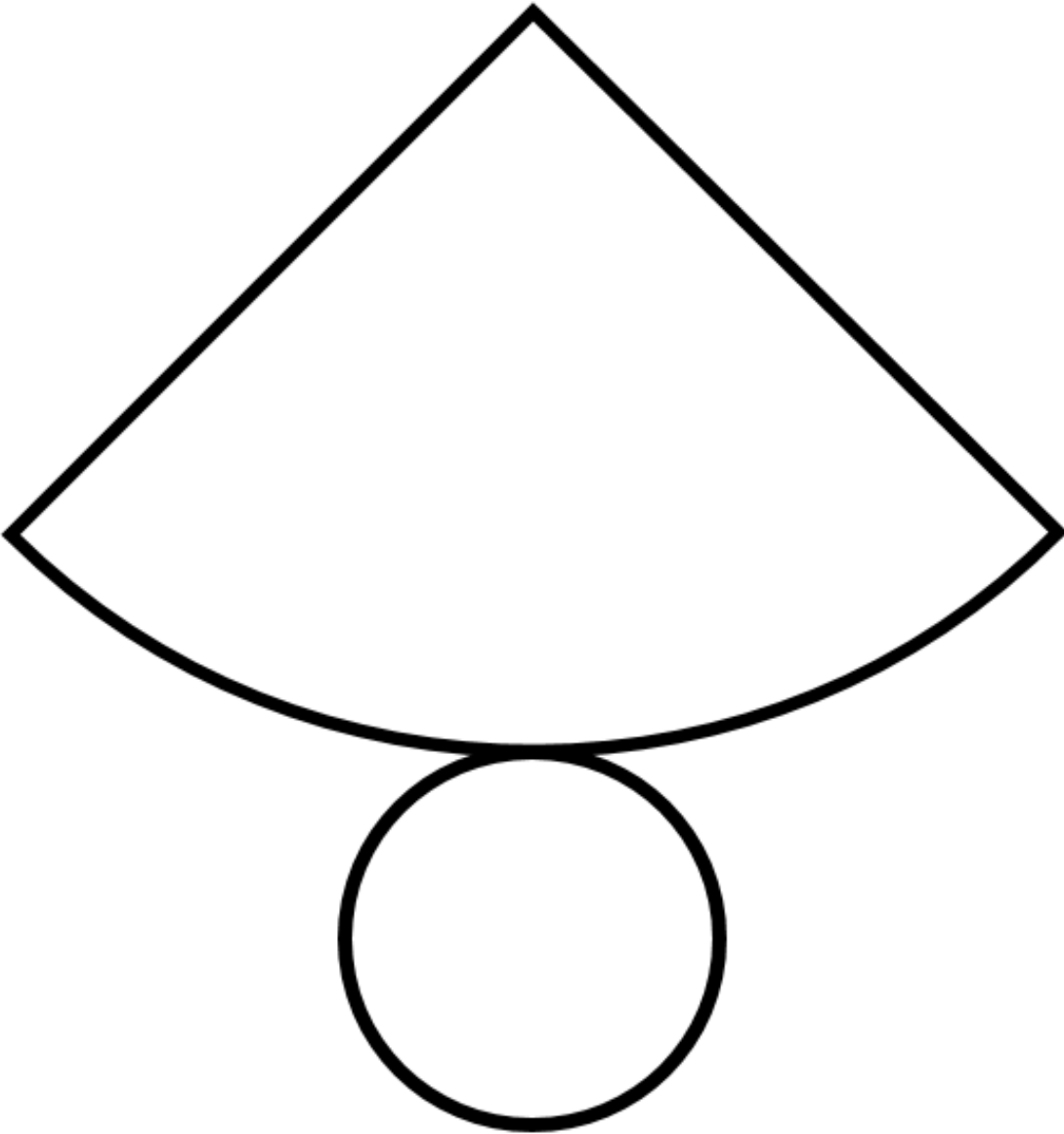

Name: \_\_\_\_\_

Date: \_\_\_\_\_

**Time to Think Questions for Cones**

How would your formula for a cone look different if the base was a different shape (for example, a triangle base)?

---

---

---

What is the difference between a cone and a cylinder?

---

---

---

Find the surface area of the following Cone.



Surface Area: \_\_\_\_\_

Name: \_\_\_\_\_

Date: \_\_\_\_\_

**Review for Quiz on Surface Area:**

## ❖ Rectangular Prism:

➤ Surface Area Formula: \_\_\_\_\_

- Ex.) Find the surface area of a box with the following dimensions: 6 inches x 4 inches x 5 inches. Show your work!

## ❖ Cylinder:

➤ Surface Area Formula: \_\_\_\_\_

- Ex.) Find the surface area of a cylinder with a radius of 2 inches and a height of 4 inches. Show your work!

## ❖ Pyramid:

➤ Surface Area Formula: \_\_\_\_\_

- Ex.) Find the surface area of a pyramid with a square base that has a side of 4 inches and a triangular side that is 5 inches tall. Show your work!

## ❖ Cone:

➤ Surface Area Formula: \_\_\_\_\_

- Ex.) Find the surface area of a cone that has a height of 11 cm and a radius of 3 cm. Show your work!

## ASSUMPTION COLLEGE EDUCATION DEPARTMENT LESSON PLAN FORMAT

## Day 5

<b>Discipline/Subject:</b>	Math/Surface Area & Volume	<b>Grade level:</b>	6th
<b>Lesson Type:</b>	Full Class	<b>Approximate length of lesson:</b>	45 minutes

<b>Topic</b>	<ul style="list-style-type: none"> <li>● Quiz on Surface Area</li> <li>● Introduction to Volume</li> </ul>
<b>Rationale</b>	This lesson will serve as an assessment and check point for the past four lessons as students will take a quiz on surface area. Then I will introduce the next unit on volume in a fun and rewarding way for students. I will reward them for their hard this week and also provide them with a real life application of volume.
<b>MA Curriculum Framework(s)</b>	<p><b>Geometry</b> <span style="float: right;"><b>6.G</b></span></p> <p><b>A. Solve real-world and mathematical problems involving area, surface area, and volume</b></p> <p>4. Represent three-dimensional figures using nets made up of rectangles and triangles and use the net to find the surface area of these figures. Apply these techniques in the context of solving real-world and mathematical problems.</p>
<b>Essential Question</b>	<ul style="list-style-type: none"> <li>● What is surface area?</li> </ul>



	<ul style="list-style-type: none"> <li>● What is volume?</li> <li>● How do you find the surface area of a 3-dimensional object?</li> </ul>
<b>Instructional Objective(s)</b>	<ul style="list-style-type: none"> <li>● Students will be able to identify and apply surface area formulas to 3-dimensional object problems.</li> <li>● Students will be able to identify and solve problems that involve the volume of a cylinder.</li> </ul>
<b>WIDA Standard(s)</b>	The Language of Math
<b>Language Domain(s)</b>	Speaking and Listening
<b>Language Objective(s):</b>	<ul style="list-style-type: none"> <li>● A level 2 ELL student will be able to solve and explain surface area problems in English using a provided sentence frame.</li> <li>● A level 4 ELL student will be able to solve and explain surface area problems in English using a provided word wall.</li> </ul>
<b>Assessment Measure(s)</b>	<p><u>Informal:</u></p> <ul style="list-style-type: none"> <li>● Student Input/Observations/Time to Think Questions: <ul style="list-style-type: none"> <li>○ Throughout this activity I will be actively walking around and checking in with the groups. I will be asking guided questions as a way to enhance students' understanding and as a checkpoint for myself to see how students are doing. Some of the questions I will ask are: <ul style="list-style-type: none"> <li>■ What mug do you think will hold the most hot chocolate?</li> <li>■ What factors affect volume?</li> <li>■ Was your initial guess right?</li> </ul> </li> </ul> </li> </ul>

	<ul style="list-style-type: none"> <li>■ How does diameter and height affect volume?</li> </ul> <p><u>Formal:</u></p> <ul style="list-style-type: none"> <li>● Quiz: <ul style="list-style-type: none"> <li>○ The quiz is going to be four questions, one on each lesson that we covered. I will not provide students with any of the formulas. However, if students were actively engaged in this week's activities, they would know that they do not need to memorize the surface area formula to get the problems correct. Students can simply add the areas of each of the faces of the objects. The quiz will be 10 points, but students have the opportunity to earn over a 100 if they received extra credit points in the Jeopardy activity during yesterday's lesson.</li> </ul> </li> </ul>
<b>Materials</b>	<ul style="list-style-type: none"> <li>● Quiz</li> <li>● Cups</li> <li>● Mugs</li> <li>● Hot chocolate</li> <li>● Marshmallows</li> <li>● Whip Cream</li> <li>● Chocolate Syrup</li> <li>● Activity Worksheet</li> <li>● Time to Think Questions</li> <li>● Pencil</li> </ul>
<b>Key Content Vocabulary</b>	<ul style="list-style-type: none"> <li>● <u>Rectangular Prism:</u> A solid (3-dimensional) object which has six faces that are rectangles.</li> <li>● <u>Cylinder:</u> A solid object with two identical flat ends that are circular or elliptical and one curved side.</li> <li>● <u>Pyramid:</u> A solid object where the sides are triangles which meet at the top and the base is a polygon.</li> </ul>

	<ul style="list-style-type: none"> <li>● <u>Cone</u>: A solid (3-dimensional) object that has a circular base joined to point by a curved side.</li> <li>● <u>Net</u>: A pattern that you can cut and fold to make a model of a solid shape.</li> <li>● <u>Face</u>: Any of the individual flat surfaces of a solid object.</li> <li>● <u>Surface Area</u>: The total area of the surface of a three-dimensional object.</li> <li>● <u>Volume</u>: The amount of 3-dimensional space something takes up.</li> </ul>
<b>Procedure</b>	
<p><b>1. Initiation</b> (15 min)</p>	<ul style="list-style-type: none"> <li>● To start the class students will be taking a quiz. The quiz should not take them that long as it is only 4 questions. The quiz will cover everything we have talked about this week. I am giving this quiz as a way to assess what knowledge the students have really taken in from this week's activities. Students with bonus points have the opportunity to earn above a perfect score on the quiz. My goal of the quiz is not to put on trick questions but to make sure that students are able to apply the knowledge they learned in this week's activities to solve surface area problems. When students are done with the quiz, I will have them flip it over and sit tight until I call time.</li> </ul>
<p><b>2. Development</b> (25 minutes)</p>	<ul style="list-style-type: none"> <li>● Today's activity will introduce the next part of the unit which is volume. Students will be working in groups of 4 to do an investigation type activity on volume of cylinders.</li> <li>● The directions for the activity will be on the board: <ul style="list-style-type: none"> <li>○ 1. The mugs will be placed in a line in the front of the classroom and everyone needs to guess which mugs can hold the most hot chocolate and record their ranking on their activity sheet.</li> <li>○ 2. Each group should take a mug (mugs will</li> </ul> </li> </ul>

	<p>have different colors: red, blue, green, purple).</p> <ul style="list-style-type: none"> <li>○ 3. Record the color of the mug you have on your activity worksheet.</li> <li>○ 4. Measure the diameter, to find the radius of the mug and record it on your activity worksheet.</li> <li>○ 5. Measure the height of the mug and record it on your activity worksheet.</li> <li>○ 6. Using the volume formula for cylinders find the volume that your mug holds. (The formula will be written on the board)</li> <li>○ 7. After your group has received each mug, rank the mugs that hold the most hot chocolate based on the volumes that you calculated.</li> <li>○ 8. Answer and discuss the Time to Think questions as a group.</li> </ul> <ul style="list-style-type: none"> <li>● The students will have five minutes with each cup to find the measurements and determine the volume.</li> <li>● The remaining five minutes will be for the Time to Think Questions which I will have the students answer with their table so they can openly discuss with each other what they have learned during the activity.</li> </ul>
<p><b>3. Closure</b> (5 min)</p>	<ul style="list-style-type: none"> <li>● To finish this week and reward the students for their hard work and effort I have a surprise for them. Since today's activity was all about hot chocolate for the last few minutes of class I am going to do a hot chocolate bar with the students. I will have hot chocolate, whipped cream, marshmallows, and chocolate syrup so students can make their own hot chocolate. Additionally, since students had a quiz today, I will not be assigning any homework for the weekend unless they did not finish the discussion questions from today's activity.</li> </ul>
<p><b>Meeting the Needs of Diverse</b></p>	<ul style="list-style-type: none"> <li>● To meet the needs of diverse learners I am having</li> </ul>

<p><b>Learners</b></p>	<p>the students complete the activity in a group of four. This will allow the students to openly discuss what they are thinking with their classmates. I put the students in groups accordingly to make sure that groups have both strong and struggling students to ensure everyone is staying on task and understanding the content being taught in the activity.</p> <ul style="list-style-type: none"> <li>● For a student who has trouble with self-monitoring and has a hard time following directions after they have been giving, I will provide this student with their own version of the activity worksheet that specifically outlines each step and what they should be doing. This will allow for this student to stay on task and actively be able to take part in their group's discussion.</li> <li>● Other executive function problems can be addressed with the following accommodations and modifications: <ul style="list-style-type: none"> <li>○ Accommodations: <ul style="list-style-type: none"> <li>■ Extended Time on quiz</li> <li>■ Immediate feedback</li> <li>■ Use of calculator</li> </ul> </li> <li>○ Modifications: <ul style="list-style-type: none"> <li>■ Less problems when taking the quiz</li> <li>■ Breaks between tasks during the activity</li> </ul> </li> </ul> </li> </ul>
<p><b>Extension/ Back-up Activity</b></p>	<ul style="list-style-type: none"> <li>● If the students finish the hot chocolate activity early, I will allow them to talk and get their hot chocolate first. I do not have an extra worksheet planned because it is Friday and the students already took a quiz and worked very hard this week and should be rewarded for their work ethic.</li> </ul>

<p>Research-Based Best Practices</p>	<p><u>Praising Appropriately</u></p> <p>-I will reward the students for their hard work this week with a hot chocolate bar</p> <p><u>Encourage Mistakes</u></p> <p>-I will encourage students to put down an answer on the quiz even if they do not think it is right because I will be able to see their thought process and can reward partial credit</p> <p><u>Going over homework correctly</u></p> <p>-The formula review sheet is online, and the Jeopardy game is accessible to students at home if they wanted to get in additionally practice</p> <p><u>Promote Resilience</u></p> <p>-I will think about students' strengths and weaknesses and put them in groups accordingly</p> <p><u>Modify Problems</u></p> <p>-There will be various levels of difficulty for the quiz problems</p> <p><u>Creating balanced tests</u></p> <p>-The quiz follows the pyramid model</p> <p><u>Multiple Representations</u></p> <p>-I will do multiple cylinder and volume examples with the students</p> <p><u>Incorporating Writing</u></p> <p>-Time to Think Questions</p> <p><u>Financial Restrictions</u></p> <p>-I will pay for the hot chocolate bar for my students</p> <p><u>Student Accountability</u></p> <p>-The students need to be a responsible member of their group and participate actively</p> <p><u>Student Behavior</u></p> <p>-If the students do not behave, they will not be allowed to have any hot chocolate</p>
--------------------------------------	--

	<p><u>State Testing</u></p> <p>-My quiz will have questions that are similar to state test questions</p> <p><u>Class Size</u></p> <p>-The class is broken into groups which makes it easier to check the understanding of students</p>
--	--

Name: \_\_\_\_\_

Date: \_\_\_\_\_

**Quiz on Surface Area**

Find the surface area of each of the following 3-dimensional shapes.

1. Sarah is wrapping a present and needs to find the surface area of the box below to determine how much wrapping paper to buy.

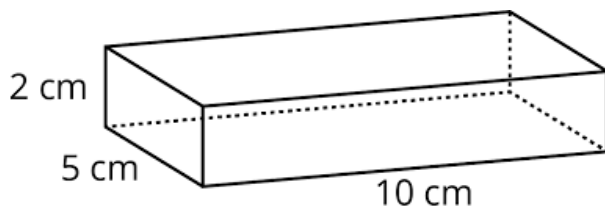

Surface Area: \_\_\_\_\_

2.

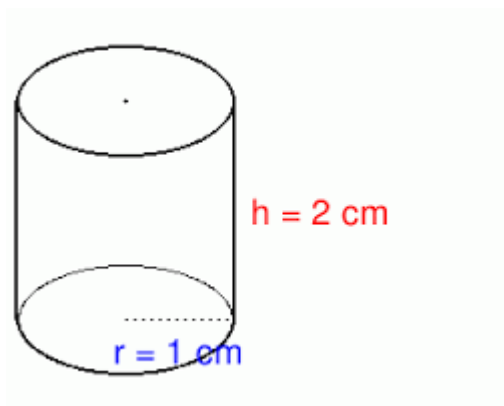

Surface Area: \_\_\_\_\_



3. Matt made a model of a pyramid he wants to build when he is older (shown below). What is the surface area of the pyramid?

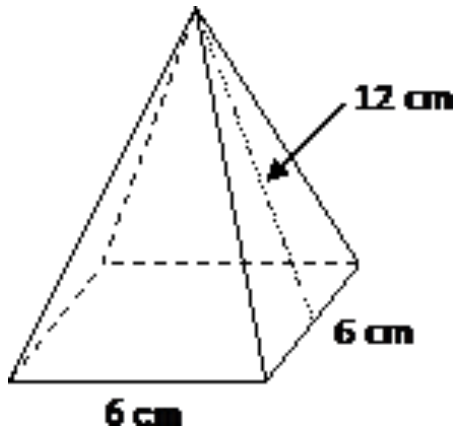

Surface Area: \_\_\_\_\_

4.

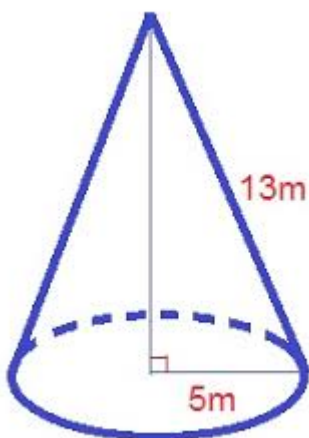

Surface Area: \_\_\_\_\_

Name: \_\_\_\_\_

Date: \_\_\_\_\_

**Hot Chocolate Activity Worksheet**

Rank the mugs in order of which mug you think will hold the most hot chocolate.

Mug	Red	Blue	Green	Purple
Ranking				

Mug Color	Radius (cm)	Height (cm)	Volume (cm <sup>3</sup> )

Actual ranking of mugs based on calculated volumes:

Mug	Red	Blue	Green	Purple
Ranking				

Name: \_\_\_\_\_

Date: \_\_\_\_\_

**Time to Think Questions for Hot Chocolate Activity**

Were your initial guesses right or wrong and why?

---

---

---

In your own words, how does the radius and height of the mug affect the volume?

---

---

---

How do you think your volume formula would change if you were measuring a cube instead of a cylinder?

---

---

---

**APPENDIX A.****Strategies:**Classroom Environment:

I aim to promote a growth mindset classroom environment in my lessons every day by varying the type of work I do to fit the needs of all students. I do full class, group, partner, and individual work in almost every lesson to make sure all types of learners are benefiting from the activities taking place. Additionally, for students who need accommodations (supports to help students access material) or modifications (changes what a student is taught/expected) I carefully think about how I can incorporate these into my activities. Other things that I do to promote a growth mindset environment is by what I have on the walls. I have a word wall for ELL students and a variety of posters to help students feel comfortable and excited to learn every day. Additionally, sending the right messages to students is something that I aim to do in a few ways. I think an important part of teaching is helping students learn both in and outside of the classroom. To do this I promote and encourage mistakes, I praise students for working hard, and I constantly encourage students to push themselves and think critically. Additionally, I try to use a lot of real life applications, so students are able to make connections with what they are learning and the outside world. I think it is important to make students strong individuals who can apply their critical thinking skills to solve problems outside of the classroom as eventually they will be the future leaders of the world.

Praising Appropriately:

Praising students for working hard is something I incorporate into every lesson. I praise students when I feel like they are going above and beyond. If students raise their hand to explain

their critical thinking or are discovering things on their own, I will praise them. If students feel comfortable sharing a mistake that they make and are allowing the class to learn from that mistake I will also praise them. Not only do I just praise students verbally, but I praise students with candy, bonus points, and even a special treat like hot chocolate as well. I feel that if I am constantly praising students for working hard then their work ethic is going to maintain at a high level or increase.

### Encouraging Mistakes:

Encouraging mistakes is something that I am going to do frequently. I think mistakes are great because everyone in the class can learn and grow from them. Throughout the activities I will be actively walking around and asking questions to the students. If I feel that multiple students are making the same mistakes, I will bring attention to that misconception and explain it to the class as I feel this is extremely beneficial. Additionally, if students make mistakes on homework questions or are not getting the correct answers for the “time to think” questions, I will provide them with constructive criticism feedback. I will not penalize students for getting a wrong answer, instead I will help guide them in the correct direction.

### Going Over Homework Effectively:

I feel that because of the hands on activities that I use throughout my lessons, homework is not something that necessarily should be assigned. A lot of the time if I do assign anything for homework it is just an extension from what students did not finish in class that day. Mostly for homework I will have students finish their “time to think” questions or work on their surface area review sheet for the quiz at the end of the week. When I do assign time to think questions for homework not only do, I give students individual feedback, but I also make sure to discuss the

questions as a class the next morning. I feel that when you are assigning homework it is critical that students get feedback to make sure they are understanding the content. Additionally, when I assign the review sheet for the upcoming quiz, I will put solutions online so students will be able to access them.

### Promoting Resilience:

I think promoting resilience in the classroom is important because it is a life lesson that all students are going to learn at some point. I teach students this lesson through the questions I ask them because they are challenging and force students to push themselves. Other ways I promote resilience is by knowing what strengths and weaknesses students have. Through this I am able to place students with partners and in groups that are the most beneficial to them. Finally, something else I can do is build strong and positive relationships with my students. Communicating with them on a first name basis, positively praising, and reinforcing students are all ways that I can promote resilience in the classroom.

### Modifying Problems:

I have not particularly planned specific ways to modify problems in my lessons because this is something where I really need to know the needs of my students before doing. However, things that I will do to ensure that all students are learning at their level and not falling behind are to be cautious when I group students. On the day that I use partners I make sure to pair students with someone who has similar math skills as them. This way I can ensure that one partner is not doing all the work while the other one is just sitting there. This also allows me to take the time to sit down with the set of partners that may be struggling more than others. Additionally, on the last day of lessons, I have students working in a group. I will make sure to

place students of mixed intelligence levels together on this day. I will do this so the students who are more advanced can help the students who may be struggling and this way no one will fall behind.

#### Creating Balanced Tests:

In my weeks' worth of lessons, I do not have a test, but I do have a variety of assessments, including a quiz. The quiz I have created is out of ten points, two of the questions are worth three points and two of the questions are worth two points. I have created questions with different point values because some of the questions are word problems and more critical thinking and application based and the other questions are more straightforward. I think creating an assessment with a variety of questions is important because it allows students to apply their knowledge at various levels. If students cannot make the full connection and think critically there are more straightforward questions that they can get correct to still receive points. Designing my tests and assessments like this should reduce the test anxiety that I see in many students. When students are able to earn points at various levels, they will be more likely to get some points rather than zero, reducing the anxiety that many students have entering a test.

#### Using Multiple Representations:

This is something that I do in each lesson to show students that what they are learning is directly connected to the outside world. In my lessons I have students bring in objects from home, I have them cut out and make their own 3-dimensional objects and I have them do word problems with specific measurements. When students are able to see content in multiple ways it allows them to get a clearer understanding of what they are learning and later helps them apply this understanding to other problems.

Asking Open Ended Questions:

Asking open ended questions is something that I ask in every lesson. I do these verbally and in my “time to think” questions. These questions are critical because they allow students to push themselves to develop a clearer understanding of the content they are learning. Through asking open ended questions, I find that students are able to self-discover formulas and formulate their thought process to examine and investigate the activities at a more advanced level.

Incorporating Writing into Lessons:

Writing is something that I incorporate into every one of my lessons. I think writing in math is so critical to enhance students’ understanding. In my lessons, students will be writing their “time to think” questions every day. I believe that when students are able to describe their thought process in writing they will have an easier time retaining the information and applying it to other problems. Having a physical copy of the students thought process in writing is also a great study guide come time for assessments.

**Barriers:**Class Length:

All of the lessons that I have planned for this week are for a 45 minutes class period. However, these lessons can be altered for both a longer and shorter class length. For a longer class period, the four days of activities can be combined into two days. I plan my lessons like this on purpose which is why Day 1 and Day 2 are similar activities and Day 3 and Day 4



are similar. This gives me more flexibility on pacing throughout my lessons. Also, if schools have longer periods, I could have created a longer quiz for the students to take on Friday.

#### Financial Restrictions:

I specifically designed my lessons to not be a financial burden. Something you will notice about my lessons are that they do not really involve technology. The only day that uses technology is on Thursday with the Jeopardy review game. I chose to create an electronic version where students can interact with it and then can access the game at home as well. However, Jeopardy can easily be done with paper and pencil and does not require technology. Otherwise everything else in my lessons is done with pencil and paper and does not require advanced textbooks or technology. Even though this does not fit the pattern of modern day schooling, this allows for schools who are more poverty stricken to still be able to afford and provide students with the materials they need to complete the activities. Additionally, I think not using technology in my lessons allows students to think more on their own and develop individual understanding to the highest level they can.

#### Student Accountability:

Student Accountability is something that my lessons require and force students to take responsibility for. Pairing students with partners and groups pushes students to be an active member of discussion. Additionally, another way that I ensure students are being accountable is that I always look at the student's "time to think" questions and give them feedback. I grade the "time to think" questions as an effort grade so if the students do not take accountability for their responses, they will not receive an effort grade for their responses.

Parental Accountability:

To ensure that parents are taking accountability in their children's educational lives I will send out a weekly newsletter on Monday to inform parents of what the students will be doing in class this week. This way the parents can have an active role and know the expectations of what their children need to complete at home. Fortunately, since I do not assign much homework the parents will not have too much responsibility placed on them. This should also help students who feel a tremendous amount of pressure from their parents. When teachers are constantly checking in with parents and have a clear form of communication, parents might not put as much pressure on their children as they will constantly know what is going on in the classroom and what steps students can take to get to where they want to be.

Student Behavior:

If students are acting up and not staying on task with the activities, I will talk to them and give them a warning. I will redirect their attention to make sure they are actively engaged in the lesson. On the day that I allow the students to pick their own partners I will warn the students that if they are not participating in the activity to their fullest potential then they will not have the opportunity to earn bonus points later in the lesson. This is an incentive for students to not get distracted. If students are still not listening, I will make them do the activity on their own and personally pull them aside to talk to them rather than call them out and embarrass them in front of the entire class. A lot of times when students are acting out it is because they are seeking peer attention, so speaking to them individually in private prevents this from happening.

State Testing:

The state requires that a certain amount of content must be taught so students are able to perform well on the state tests. I planned my lessons in a way that is not traditional as my lessons take a very strong hands-on approach. To ensure that I am sticking to the state curriculum and am staying on track with my lessons, I planned activities that involve less repetition with practice and more self-discovery among the students. In my lessons I will present a different three-dimensional object each day, all of which are covered on the state tests. Having the students discover the formulas on their own allows them to take in what they are learning and gives the students a deeper and more clear understanding of the content. Another benefit of planning my lessons this way is that it does not require extensive homework repetition practice.

Class Size:

Every single one of my lessons can be done with a large or small group class. I did individual, partner, group, and full class work which can be done with any size class. Having variety in the way you group students allows the students in big classes and smaller classes to all benefit. Grouping is especially important when you have a bigger class because breaking the class into smaller groups still allows you to actively check in with each group and assess individual students' understanding. My specific lessons are designed for a class of about 16-20 students. If students are constantly being paired with a new group or a new partner, they are given the opportunity to interact and make connections with their peers. This can lead to the start of new friendships and can make students feel more welcome and comfortable in their classroom environment.

## CONCLUSION

After completing a literature review and creating lesson plans designed to promote a growth mindset, I realize the dramatic effect developing a growth mindset can have on students. By praising students for their effort, encouraging mistakes, promoting resilience, and using diverse assessments, teachers have the ability to change their students' mindsets which may change their entire outlook on life. These strategies provide teachers with the tools and knowledge they need to change the fixed mindset that many students have by allowing students to see that they can always grow and improve. However, before being able to successfully implement these strategies there are certain barriers that teachers need to take into consideration. These barriers include length of the class period, financial restraints, student accountability and attendance, lack of support from home, behavioral issues, state testing, class size, and excessive stress. To overcome these barriers while still aiming at promoting a growth mindset, I have developed a week of lesson plans that showcase the strategies above.

**UNANNOTATED BIBLIOGRAPHY**

- Boaler, Jo. "Chapter 2: The Power of Mistakes and Struggle." *Mathematical Mindsets: Unleashing Students' Potential through Creative Math, Inspiring Messages, and Innovative Teaching*. Jossey-Bass & Pfeiffer Imprints, San Francisco 2016.
- Chen, Michelle. "How Unequal School Funding Punishes Poor Kids." *The Nation*, 14 May 2018, [www.thenation.com/article/how-unequal-school-funding-punishes-poor-kids/](http://www.thenation.com/article/how-unequal-school-funding-punishes-poor-kids/).
- "Chronic Absenteeism in the Nation's Schools." *Chronic Absenteeism in the Nation's Schools*, Jan. 2019, [www2.ed.gov/datastory/chronicabsenteeism.html](http://www2.ed.gov/datastory/chronicabsenteeism.html).
- Cromwell, Sharon. "Are Smaller Classes the Answer?" *Smaller vs. Larger Classes | Education World*, 19 Feb. 2005, [www.educationworld.com/a\\_admin/admin/admin091.shtml](http://www.educationworld.com/a_admin/admin/admin091.shtml).
- Dekker, Truus. "A Model for Constructing Higher Level Classroom Assessments." *The Mathematics Teacher*, vol 101, no. 1, pp. 56-61. JSTOR.
- Dillon, Sam. "Formula to Grade Teachers' Skill Gains Acceptance, and Critics." *The New York Times*, The New York Times, 1 Sept. 2010, [www.nytimes.com/2010/09/01/education/01teacher.html](http://www.nytimes.com/2010/09/01/education/01teacher.html).
- Durmus, Soner, and Erol Karakirik. "Virtual Manipulatives in Mathematical Education: A Theoretical Framework." *The Turkish Online Journal of Educational Technology*, 1 Jan. 2006, [files.eric.ed.gov/fulltext/ED496007.pdf](http://files.eric.ed.gov/fulltext/ED496007.pdf).
- Dweck, Carol S. "Boosting Achievement with Messages that Motivate." *Canadian Education Association*, pp. 6-10. EDUCATION CANADA.

- Dweck, Carol S. "Even Geniuses Work Hard." *Education Leadership*, September 2010, pp.16-20. ASCD
- Dweck, Carol S. "The Perils and Promises of Praise." *Education Leadership*, pp. 34-39. October 2007.
- Felton, Emmanuel. "Are American Class Periods Too Short for Common Core?" *The Hechinger Report*, The Hechinger Report, 25 Nov. 2014, [hechingerreport.org/american-class-periods-short-common-core/](http://hechingerreport.org/american-class-periods-short-common-core/).
- Garcia, Katie and Davis, Alicia. "Problem Analysis: Challenging All Learners." *The Mathematics Teacher*, vol. 107, no. 5, 2014, pp. 348–353. JSTOR.
- Gish, Jennifer. "Poll Looks at Favorite High School Subjects, Tech Opinions." *HealthyLife Magazine*, Times Union, 20 Aug 2012 [blog.timesunion.com/parenting/18239/-poll-looks-at-favorite-high-school-subjects-tech-opinions/](http://blog.timesunion.com/parenting/18239/-poll-looks-at-favorite-high-school-subjects-tech-opinions/)
- Haltiwanger, Leigh and Simpson, Amber M. "Beyond the Right Answer: Mathematical Connections." *Mathematics Teaching In The Middle School*, vol. 18, no. 8, 2013, pp 494-498. JSTOR
- "How Parent Involvement Leads to Student Success." *Waterford.org*, 1 Nov. 2018, [www.waterford.org/education/how-parent-involvement-leads-to-student-success/](http://www.waterford.org/education/how-parent-involvement-leads-to-student-success/).
- Kremer, Kristen P, et al. "Behavior Problems and Children's Academic Achievement: A Test of Growth-Curve Models with Gender and Racial Differences." *Children and Youth Services Review*, U.S. National Library of Medicine, Aug. 2016, [www.ncbi.nlm.nih.gov/pmc/articles/PMC5436618/](http://www.ncbi.nlm.nih.gov/pmc/articles/PMC5436618/).

Otten, Samuel, Cirillo, Michelle, and Herbel-Eisenmann, Beth A. "Making the Most of Going over Homework." *Mathematics Teaching In The Middle School*, vol. 21, no. 2, 2015, pp 98-105. JSTOR.

"Muscle Memory." *Merriam-Webster*, Merriam-Webster, [www.merriam-webster.com/dictionary/muscle%20memory](http://www.merriam-webster.com/dictionary/muscle%20memory).

Perlstein, Linda. *Not Much, Just Chillin': the Hidden Lives of Middle Schoolers*. Ballantine Books, 2004.

Rampell, Catherine. "Class Size Around the World." *The New York Times*, The New York Times, 11 Sept. 2009, [economix.blogs.nytimes.com/2009/09/11/class-size-around-the-world/](http://economix.blogs.nytimes.com/2009/09/11/class-size-around-the-world/).

Reel Link Films presents ; a film by Vicki Abeles ; directed by Vicki Abeles & Jessica Congdon. *Race To Nowhere*. Lafayette, CA :Reel Link Films, 2011. Print.

Rider, Robin. "Shifting from Traditional to Non Traditional Teaching Practices Using Multiple Representations." *The Mathematic Teacher*, vol. 100, no. 7, 2007, pp 494-500. JSTOR.

Sanchez, Wendy B. "Open-Ended Questions and The Process Standards." *The Mathematics Teacher*, vol. 107, no. 3, 2013, pp 206-211. JSTOR.

Smith, Margaret S, and Mary Kay Stein. 5 Practices for Orchestrating Productive Mathematics Discussions. National Council of Teachers of Mathematics. Reston, VA. 2018

Stone, Lisanne L, et al. "The Strengths and Difficulties Questionnaire: Psychometric Properties of the Parent and Teacher Version in Children Aged 4-7." *BMC Psychology*, BioMed Central, 20 Feb. 2015, [www.ncbi.nlm.nih.gov/pmc/articles/PMC4364334/](http://www.ncbi.nlm.nih.gov/pmc/articles/PMC4364334/).

“Survey Results: Top 10 Barriers to Student Success.” *The School Planner Company*, 9 Oct. 2018, [www.schoolplanner.com/2018/03/01/barriers-student-success/](http://www.schoolplanner.com/2018/03/01/barriers-student-success/).

Thompson, Karl. “Teacher Labelling and the Self-Fulfilling Prophecy #Class Notes.” *ReviseSociology*, 4 Nov. 2017, [revisesociology.com/2017/11/01/labelling-self-fulfilling-prophecy-education/](http://revisesociology.com/2017/11/01/labelling-self-fulfilling-prophecy-education/).

Yeager, David Scott and Dweck, Carol S. “Mindset that Promote Resilience: When Students Believe that Personal Characteristics can be Developed.” *Educational Psychologists*, vol. 47, no. 4, pp. 302-314, 2012.



**PICTURES CITED:**

<https://images.app.goo.gl/bbvqXgg14AZwvpv5Q8>

<https://images.app.goo.gl/RNUXG9SaDQBQzftL7>

<https://images.app.goo.gl/4WnWpD597bwCsHAEA>

<https://images.app.goo.gl/VVgUpUw26w8VcRaS6>

<https://images.app.goo.gl/13F5Z9wmDS2bhZUd7>

<https://images.app.goo.gl/Ej45fzDKiBDwCYL28>

<https://images.app.goo.gl/c3LJdk9UPhavY6cP6>

<https://images.app.goo.gl/GLodnehiA82ASXYs5>

<https://images.app.goo.gl/d6JxcPgu17BFkZ3k8>

<https://images.app.goo.gl/TCRqFkNMeeRLDJac7>

<https://images.app.goo.gl/NmykhbmDSWUuaJb2A>

<https://images.app.goo.gl/CMorashDprMTNLfJ6>

<https://images.app.goo.gl/XgbDiQf8XLQ6Go1a7>

<https://images.app.goo.gl/e9Qq4ifdQtnZ7CLeA>

<https://images.app.goo.gl/S1CfsC3awVbcS1Pm8>

<https://images.app.goo.gl/MegrUU95Wxqq3mmo8>

<https://images.app.goo.gl/rrrb22HUVJGVpLDN6>

<https://images.app.goo.gl/fLTigrVZvPcjQzsW9>