

University of New Mexico

UNM Digital Repository

Faculty and Staff Publications

Mathematics

2014

New Techniques to Analyse the Prediction of Fuzzy Models

Florentin Smarandache

University of New Mexico, smarand@unm.edu

W.B. Vasantha Kandasamy

vasanthakandasamy@gmail.com

K. Ilanthenral

ilanthenral@gmail.com

Follow this and additional works at: https://digitalrepository.unm.edu/math_fsp



Part of the [Algebra Commons](#), [Analysis Commons](#), [Logic and Foundations Commons](#), and the [Other Mathematics Commons](#)

Recommended Citation

W.B. Vasantha Kandasamy, F. Smarandache, K. Ilanthenral. *New Techniques to Analyse the Prediction of Fuzzy Models*. Brussels: EuropaNova ASBL, 2014.

This Book is brought to you for free and open access by the Mathematics at UNM Digital Repository. It has been accepted for inclusion in Faculty and Staff Publications by an authorized administrator of UNM Digital Repository. For more information, please contact amywinter@unm.edu, lsloane@salud.unm.edu, sarahrk@unm.edu.



**W.B.VASANTHA KANDASAMY
FLORENTIN SMARANDACHE
ILANTHENRAL.K**

**NEW TECHNIQUES TO
ANALYSE THE PREDICTION OF
FUZZY MODELS AND
NEUTROSOPHIC MODELS**

New Techniques to Analyse the Prediction of Fuzzy Models

**W. B. Vasantha Kandasamy
Florentin Smarandache
Ilanthenral K**



2014

This book can be ordered from:

EuropaNova ASBL
Clos du Parnasse, 3E
1000, Bruxelles
Belgium
E-mail: info@europanova.be
URL: <http://www.europanova.be/>

Copyright 2014 by *EuropaNova* ASBL and the *Authors*

Peer reviewers:

Dr. Stefan Vladutescu, University of Craiova, Romania.
Dr. Octavian Cira, Aurel Vlaicu University of Arad, Romania.
Mumtaz Ali, Department of Mathematics, Quaid-i-Azam
University, Islamabad, 44000, Pakistan
Said Broumi, University of Hassan II Mohammedia,
Hay El Baraka Ben M'sik, Casablanca B. P. 7951.
Morocco.

Many books can be downloaded from the following
Digital Library of Science:
<http://www.gallup.unm.edu/eBooks-otherformats.htm>

ISBN-13: 978-1-59973-297-8
EAN: 9781599732978

Printed in Europe and United States of America

CONTENTS

Preface	5
Chapter One INTRODUCTION	7
Chapter Two MERGED FCMS AND NCMS MODELS	9
Chapter Three KOSKO-HAMMING DISTANCE IN FCMS AND NCMS	127
Chapter Four NEW AVERAGE FCMS AND NEW AVERAGE NCMS	159

Chapter Five	
INFLUENTIAL OR VITAL NODES OF FCMS AND NCMs	185
FURTHER READING	227
INDEX	240
ABOUT THE AUTHORS	242

PREFACE

For the first time authors have ventured to study, analyse and investigate the properties of the fuzzy models, the experts opinion and so on. Here the concept of merged Fuzzy Cognitive Maps and Neutrosophic Cognitive Maps are carried out, which are based on merged graphs and merged matrices. This concept is better than the usual combined Fuzzy Cognitive Maps. Further by this new technique we are able to give equal importance to all the experts who work with the problem.

Here the new concept of New Average Fuzzy Cognitive Maps and Neutrosophic Cognitive Maps is defined and described. This new tool helps in saving time and economy.

Another new tool called Kosko Hamming distance of FCMs and NCMs are defined which measures the closeness or otherwise of the experts. The node with maximum vertices is usually termed as a powerful node but here the influential node

in a FCMS (NCMS) is a node whose on state makes on the most number of nodes in the hidden pattern given by it.

We wish to acknowledge Dr. K Kandasamy for his sustained support and encouragement in the writing of this book.

W.B.VASANTHA KANDASAMY
FLORENTIN SMARANDACHE
ILANTHENRAL K

Chapter One

INTRODUCTION

In this book we mainly analyse FCMs and NCMs. This analysis by authors will lead the expert to understand more about the problem. The main aim of the authors was a FCM or a NCM does not in general function on the opinion of a single expert but several experts. In [45, 79] the notion of combined FCMs and NCMs are given. However combined FCMs (or NCMs) has the disadvantage of canceling of the -1 with $+1$.

But one believes in the law of large numbers so we have to build a method which can cater to each and every experts opinion equally and also save time and economy. This has been done in chapter IV where the new average simple FCMs and NCMs are built and described. This newly modeled FCMs (NCMs model) not only treats every expert equally but also saves time and economy by working with a single dynamical system.

Also a study of distance between hidden patterns of the same initial state vectors analysed by two different experts by a new method is carried out. This is defined as Kosko-Hamming distance which measures whether two experts opinion are close or very much deviant for a given initial state vector.

This study is new and innovative for these Kosko Hamming distance is defined only if two experts work on the same problem with same number of attributes on the same initial state vector. Such study exhibits the distance between two experts on one specific initial state.

Now another important technique when the number of attributes involved for study is very large we use the newly defined concept of merged FCMs and NCMs. There are three types of merging and they are discussed with examples. The authors wish to keep on record that all the examples given in this book are just illustrations and they are not any real material worked with the real world problems.

To get the merged FCMs or NCMs the reader must be familiar with working of the directed merged neutrosophic graphs. For this concept please refer [100]. Now using this concept of merged graphs in the directed graphs given by the experts we can study merged FCMs. This is better than combined FCMs (or NCMs) for merging does not affect the entries of the connection matrix drastically. Such analysis and study is described and developed in chapter II of this book.

However in [100] the authors have already done a new concept on FCMs known as the special combined FCMs. In this case entries greater than 1 can also occur. This is not merged so we call them as overlapping FCMs.

For more about FCMs and NCMs please refer [79].

Chapter Two

MERGED FCMS AND NCMS MODELS

In this chapter we introduce the new notion of Merged Fuzzy Cognitive Maps model (MFCMs model) and Merged Neutrosophic Cognitive Maps model (MNCMs model).

Merged graphs and lattices got by merging the vertices or edges or both have been discussed in the book [100].

Here we study mainly pseudo lattice graphs of type II where we take two graphs and merge a vertex of one with other or take two graphs and merge a edge of one with other or both or several vertices or several edges or both are merged.

We will illustrate this situation by some examples.

Example 2.1: Let $G_1 =$

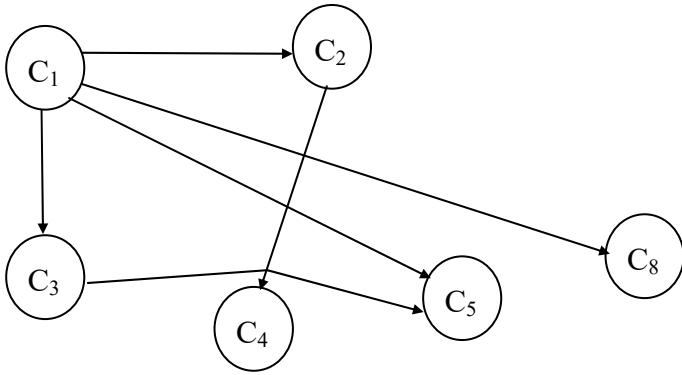

and $G_2 =$

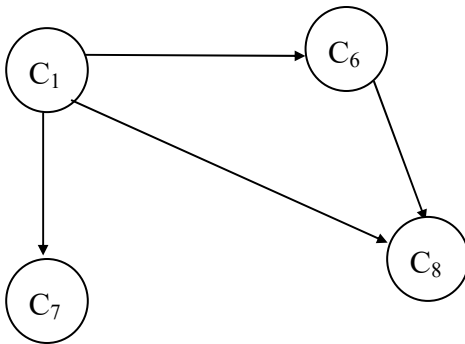

be any two directed graphs. The pseudo lattice graph of type II is got by merging the vertex C_1 of G_1 with vertex C_1 of G_2 [100].

This is a special type of merging for only the node C_1 is common so merging of other types cannot take place in this case.

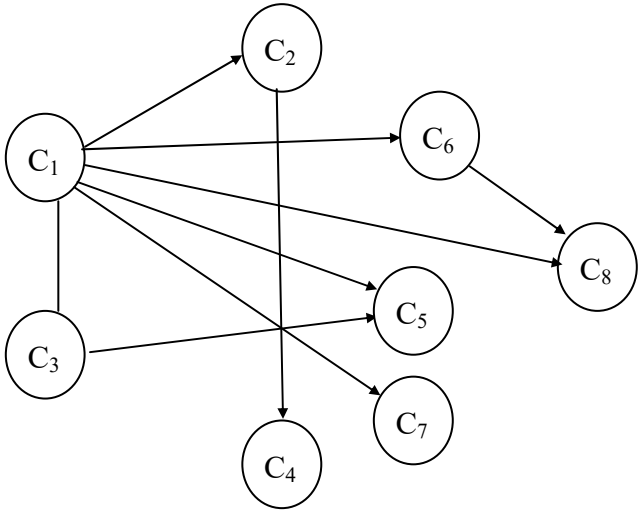

Now these graphs cannot be merged in any other way other than the one mentioned.

However merging of any two arbitrary graphs can be made in any number of ways.

Example 2.2: Let $G_1 =$

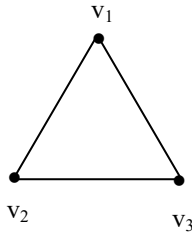

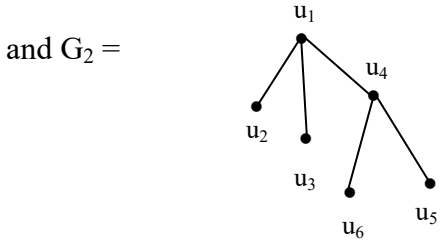

be any two graphs. The vertices are different so the merging a single vertex of G_1 with G_2 or an edge of G_1 with G_2 or both or many vertices and many edges of G_1 with G_2 can be carried out.

It is infact an open problem if G_1 has n_1 vertices and m_1 edges and if the graph G_2 has n_2 vertices and m_2 edges how many pseudo lattice graphs of type II can be got.

Now we give a few pseudo lattice graphs of type II.

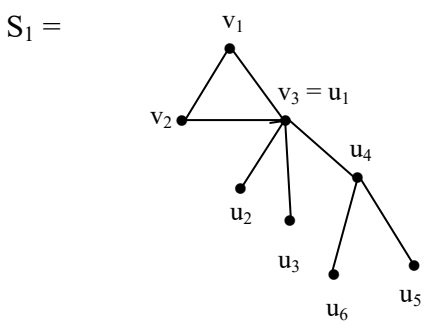

is pseudo lattice graph of type II.

We can get S_2 by merging v_1 with u_5 which is as follows.

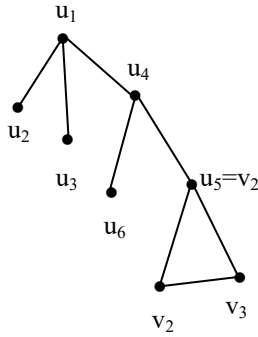

is again a graph.

Consider S_3 got by merging v_1v_2 of G_1 with u_1u_4 of G_2 which is as follows.

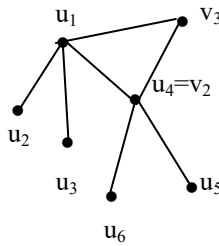

We merge u_1 with v_1 , v_2 with u_2 and u_4 with v_3 and obtain the following pseudo lattice graph of type II.

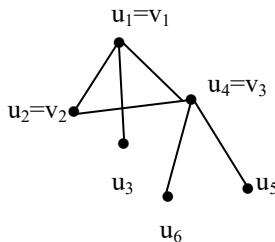

We can have several such pseudo lattice graphs of type II.

Example 2.3: Let $G_1 =$

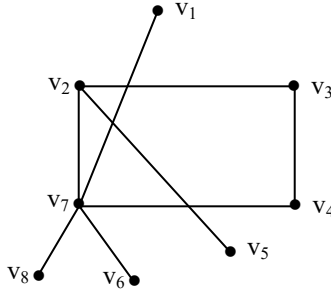

$G_2 =$

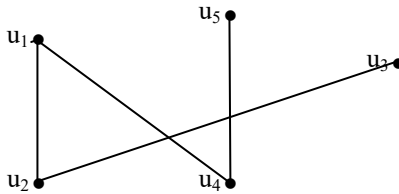

be any two graphs.

Find the number of pseudo lattice graphs of type II got using G_1 and G_2 .

We give one or two examples of them.

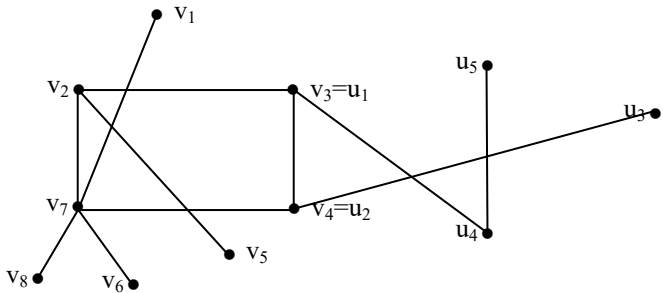

We can merge v_1 with v_2 and u_2 with v_5 .

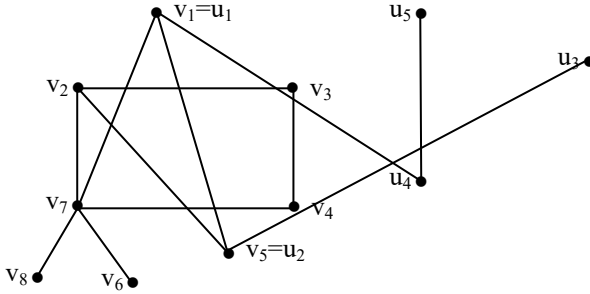

We have several such pseudo lattice graphs of type II.

Now we proceed onto describe merging of vertices or edges or so of more than two graphs by some examples.

Example 2.4: Let G_1 , G_2 and G_3 be three graphs given in the following.

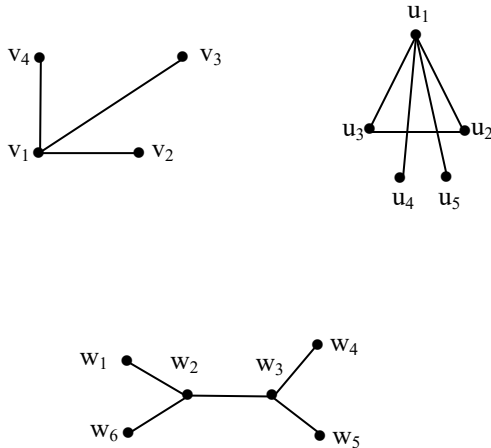

We can merge v_3 with u_4 and w_1 and u_5 get the following pseudo lattice graph of type II.

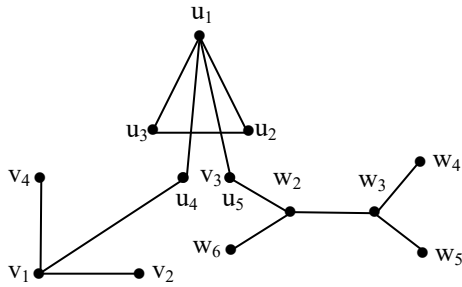

We can also merge w_2 w_3 with u_3 u_2 and v_1 v_4 and get the following pseudo lattice graph of type II.

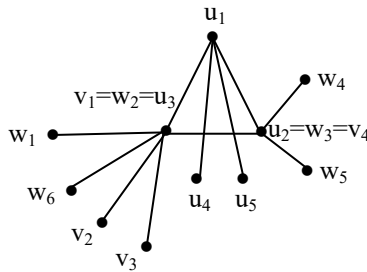

Now we can merge the vertices v_3 and u_4 and u_2 with w_1 and get the pseudo lattice graph of type II which is as follows:

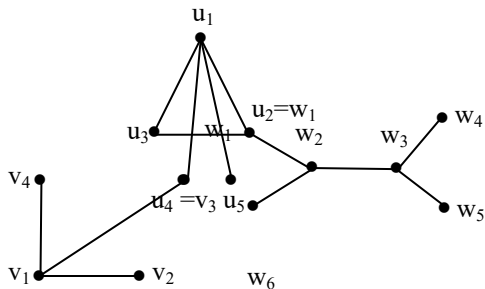

It is pertinent to keep on record that we need not always merge all the graphs together. We can merge them in a cycle say G_1 to G_2 , G_2 to G_3 or G_3 to G_1 and G_1 to G_2 or G_2 to G_3 and G_3 to G_1 .

It is still an open problem to find the number of pseudo lattice graphs of type II using 3 graphs whose number of vertices and edges are known.

Thus we can have pseudo lattice graphs of type II having more than 3 graphs also. All these new techniques are used in the problems of FCMs models and NCMs models. However in case of using in these models we have one and only one pseudo lattice graph of type II. For more about these concepts refer [100].

We will now describe the use of these in Fuzzy Cognitive Maps models.

In the first place to use the concept of merging of vertices or edges or both of the directed graphs associated with the FCMs model we mainly need all the related directed graphs pertain to the same problem and they are modeled or studied using only FCMs.

Only after ascertaining this we can proceed onto use the concept of merging of graphs. Further we also need the concept of merged matrices.

We will just define the notion of merged matrices.

Suppose G_1 and G_2 are two graphs given in the following:

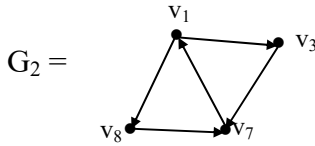
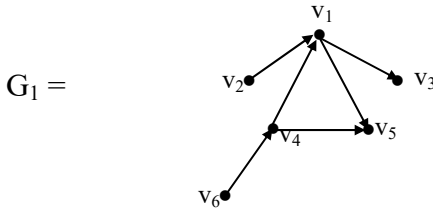

The matrices M_1 and M_2 associated with G_1 and G_2 are given in the following.

$$M_1 = \begin{matrix} & v_1 & v_2 & v_3 & v_4 & v_5 & v_6 \\ \begin{matrix} v_1 \\ v_2 \\ v_3 \\ v_4 \\ v_5 \\ v_6 \end{matrix} & \begin{bmatrix} 0 & 0 & 1 & 0 & 1 & 0 \\ 1 & 0 & 0 & 0 & 0 & 0 \\ 0 & 0 & 0 & 0 & 0 & 0 \\ 1 & 0 & 0 & 0 & 1 & 0 \\ 0 & 0 & 0 & 0 & 0 & 0 \\ 0 & 0 & 0 & 1 & 0 & 0 \end{bmatrix} \end{matrix}$$

$$\text{and } M_2 = \begin{matrix} & v_1 & v_3 & v_7 & v_8 \\ \begin{matrix} v_1 \\ v_3 \\ v_7 \\ v_8 \end{matrix} & \begin{bmatrix} 0 & 1 & 0 & 1 \\ 0 & 0 & 1 & 0 \\ 1 & 0 & 0 & 0 \\ 0 & 0 & 1 & 0 \end{bmatrix} \end{matrix}.$$

The merged graph of G_1 with G_2 is as follows:

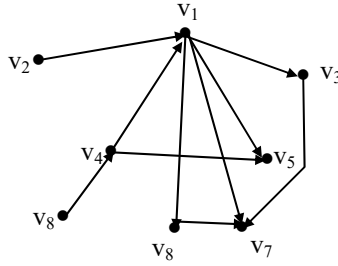

The merged matrix M to M_1 and M_2 is as follows.

$$M = \begin{matrix} & v_1 & v_2 & v_3 & v_4 & v_5 & v_6 & v_7 & v_8 \\ \begin{matrix} v_1 \\ v_2 \\ v_3 \\ v_4 \\ v_5 \\ v_6 \\ v_7 \\ v_8 \end{matrix} & \begin{bmatrix} 0 & 0 & 1 & 0 & 1 & 0 & 0 & 1 \\ 1 & 0 & 0 & 0 & 0 & 0 & 0 & 0 \\ 0 & 0 & 0 & 0 & 0 & 0 & 0 & 1 \\ 1 & 0 & 0 & 0 & 0 & 0 & 0 & 1 \\ 0 & 0 & 0 & 0 & 0 & 0 & 0 & 0 \\ 0 & 0 & 0 & 1 & 0 & 0 & 0 & 0 \\ 1 & 0 & 0 & 0 & 0 & 0 & 0 & 0 \\ 0 & 0 & 0 & 0 & 0 & 0 & 1 & 0 \end{bmatrix} \end{matrix} .$$

We see the presence of both M_1 and M_2 as submatrices exist. So we can merge two matrices M_1 and M_2 into a matrix M if M_1 and M_2 are submatrices of M. (when the rows and columns of a matrix is deleted the resultant matrix is also defined as a submatrix).

Now in case of merged FCMs the merged matrix serves as the dynamical system of the merged FCMs. Further these merged matrices are the matrices associated with the directed graphs of the FCMs.

Finally we can merge two FCMs if and only if they have atleast a common node or edge or both. Further if they have an

edge in common they should also be in the same direction as that of the others. Only then merging can be done.

We cannot merge $u_1 \bullet \longrightarrow \bullet u_2$ with $u_1 \bullet \longleftarrow \bullet u_2$.

For we can in this case merge u_2 with u_2 or u_1 with u_1 and the edges cannot be merged as they are in opposite directions.

Suppose we have three experts working in the same problem with some concepts $c_1, c_2, c_3, \dots, c_8$. They express their opinion in the graphs G_1, G_2 and G_3 which is given in the following:

$G_1 =$

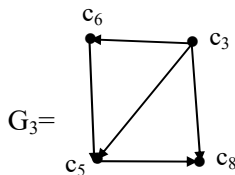
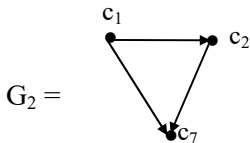
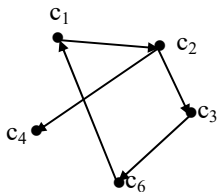

The matrices related with the graphs are as follows:

$$M_1 = \begin{matrix} & c_1 & c_2 & c_3 & c_4 & c_6 \\ \begin{matrix} c_1 \\ c_2 \\ c_3 \\ c_4 \\ c_6 \end{matrix} & \begin{bmatrix} 0 & 1 & 0 & 0 & 0 \\ 0 & 0 & 1 & 1 & 0 \\ 0 & 0 & 0 & 0 & 1 \\ 0 & 0 & 0 & 0 & 0 \\ 1 & 0 & 0 & 0 & 0 \end{bmatrix} \end{matrix}$$

is the matrix of the graph G_1 .

$$M_2 = \begin{matrix} & c_1 & c_2 & c_7 \\ c_1 & 0 & 1 & 1 \\ c_2 & 0 & 0 & 1 \\ c_7 & 0 & 0 & 0 \end{matrix} \text{ is the matrix of the graph } G_2.$$

$$M_3 = \begin{matrix} & c_3 & c_5 & c_6 & c_8 \\ c_3 & 0 & 1 & 1 & 1 \\ c_5 & 0 & 0 & 0 & 1 \\ c_6 & 0 & 1 & 0 & 0 \\ c_8 & 0 & 0 & 0 & 0 \end{matrix} \text{ is the matrix of } G_3.$$

The merged graph G of G_1 , G_2 and G_3 is as follows:

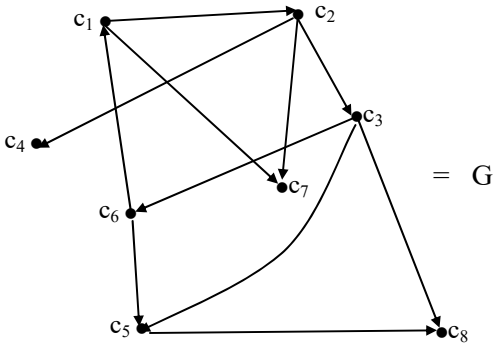

The matrix related with the merged graph G is as follows:

$$M = \begin{matrix} & c_1 & c_2 & c_3 & c_4 & c_5 & c_6 & c_7 & c_8 \\ \begin{matrix} c_1 \\ c_2 \\ c_3 \\ c_4 \\ c_5 \\ c_6 \\ c_7 \\ c_8 \end{matrix} & \begin{bmatrix} 0 & 1 & 0 & 0 & 0 & 0 & 1 & 0 \\ 0 & 0 & 1 & 1 & 0 & 0 & 1 & 0 \\ 0 & 0 & 0 & 0 & 1 & 1 & 0 & 1 \\ 0 & 0 & 0 & 0 & 0 & 0 & 0 & 0 \\ 0 & 0 & 0 & 0 & 0 & 0 & 0 & 1 \\ 1 & 0 & 0 & 0 & 1 & 0 & 0 & 0 \\ 0 & 0 & 0 & 0 & 0 & 0 & 0 & 0 \\ 0 & 0 & 0 & 0 & 0 & 0 & 0 & 0 \end{bmatrix} \end{matrix} .$$

Now we can easily verify that M is also the merged matrix of the matrices M_1 , M_2 and M_3 . This is the way we get merged matrices and pseudo lattice graphs of type II.

Merging of matrices must obey the following law. If M_1, M_2, \dots, M_n are n matrices if M is the merged matrix then M_1, M_2, \dots, M_n must be submatrices of M . Then only we call M to be the merged matrix of M_1, M_2, \dots, M_n .

We see for merging of matrices M_i and M_j they must have atleast a a_{is} to be common between M_i and M_j for some i and j in $1 \leq i, j \leq n$.

Similarly for merging graph at least a vertex or an edge must be common in case of graphs associated with fuzzy models like FCMs or NCMs or NRM or FRMs.

Keeping these conditions in mind we illustrate the situation in case of FCMs.

Example 2.5: Let us consider the problem of passengers preference maximum utilization of a bus route in Madras city [92], the comfort, waiting time, congestion in the vehicle and so on. We first give the attributes suggested by the experts in the following.

- C_1 - Frequency of the vehicle along the route.
- C_2 - In vehicle travel time along the route.
- C_3 - Travel fare along the route.
- C_4 - Speed of the vehicles along the route.
- C_5 - Number of intermediate points in the route.
- C_6 - Waiting time.
- C_7 - Number of transfers in the route.
- C_8 - Congestion in the vehicle.

Suppose the first expert wishes to work with the five attributes.

C_1, C_2, C_3, C_4, C_5 and C_6 .

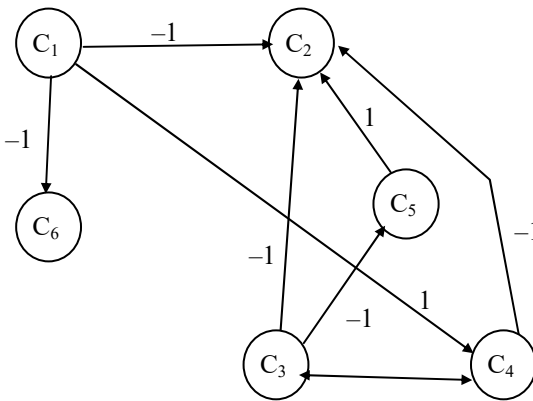

The second expert works with the nodes C_3, C_6, C_8 and C_7 and the directed graph given by him is as follows:

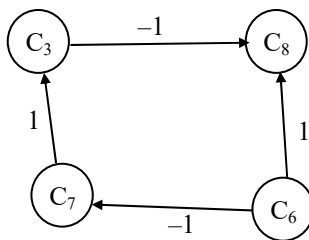

Now the graph can be merged by merging the vertex C_3 with C_6 and the vertex C_6 with C_6 .

The merged graph is as follows:

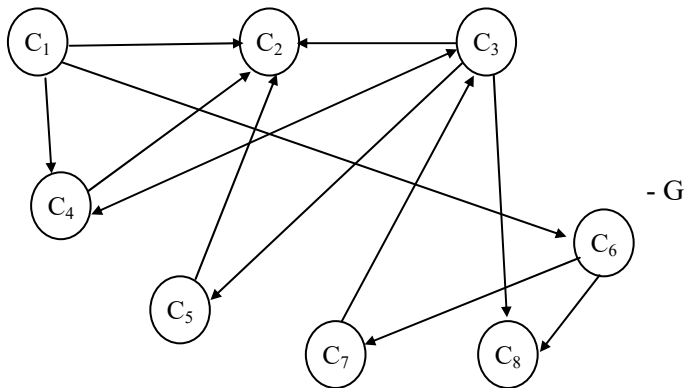

The merged matrix of the merged graph G is as follows:

$$M = \begin{matrix} & \begin{matrix} c_1 & c_2 & c_3 & c_4 & c_5 & c_6 & c_7 & c_8 \end{matrix} \\ \begin{matrix} c_1 \\ c_2 \\ c_3 \\ c_4 \\ c_5 \\ c_6 \\ c_7 \\ c_8 \end{matrix} & \begin{bmatrix} 0 & -1 & 0 & 1 & 0 & -1 & 0 & 0 \\ 0 & 0 & 0 & 0 & 0 & 0 & 0 & 0 \\ 0 & -1 & 0 & 1 & -1 & 0 & 0 & -1 \\ 0 & -1 & 1 & 0 & 0 & 0 & 0 & 0 \\ 0 & 1 & 0 & 0 & 0 & 0 & 0 & 0 \\ 0 & 0 & 0 & 0 & 0 & 0 & -1 & 1 \\ 0 & 0 & 1 & 0 & 0 & 0 & 0 & 0 \\ 0 & 0 & 0 & 0 & 0 & 0 & 0 & 0 \end{bmatrix} \end{matrix} .$$

Using M we get the solution of the problem using the merged FCMs model.

Here merging of the common vertex C_3 of the directed graphs related with the FCMs is carried out.

We can also have a merging of an edge. This is illustrated in the following.

The directed graph given by expert I using C_1, C_5, C_6, C_7 and C_8 .

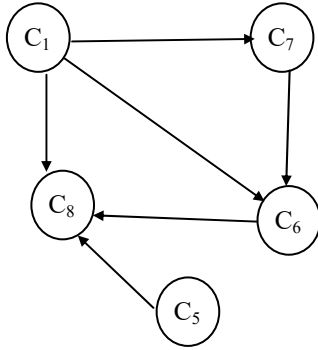

Let C_1, C_7, C_8, C_3, C_4 and C_2 be the nodes taken by the second expert who has given the following directed graph.

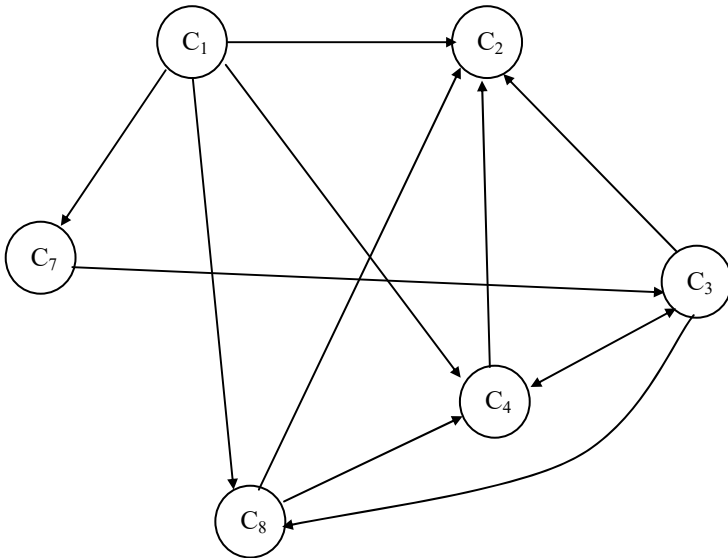

Now the unique merged graph of the directed graphs associated with the FCM is as follows.

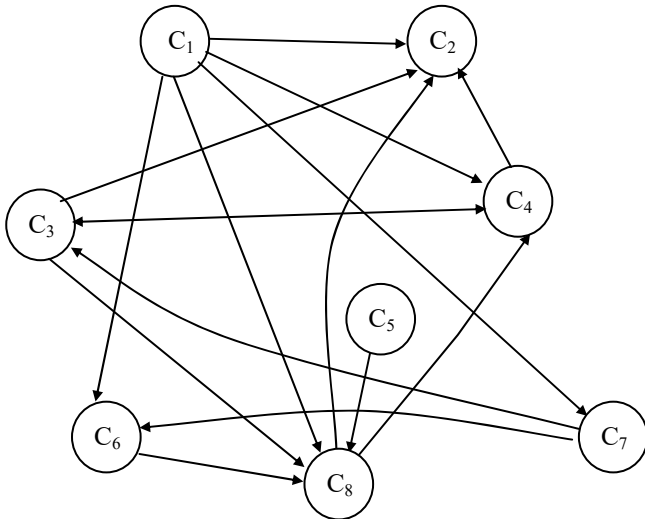

We merge vertices C_1 , C_7 and C_8 and edges C_1 , C_7 and C_1 , C_8 in this merged graph.

Thus using this merged model we can find the merged connection matrix of the FCM using which we can analyse the problem.

Let C_1 , C_2 , C_3 , C_4 and C_6 be used by the first expert who gives the following directed graph.

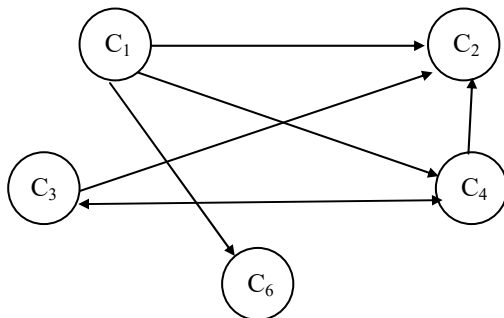

Using C_1 C_2 C_5 C_7 and C_8 the following directed graph is given by the second expert.

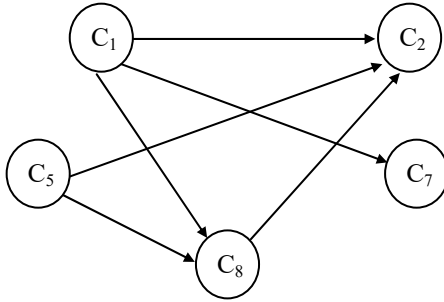

Now we can merge these two directed graphs associated with the FCMs in one edge C_1 to C_2 and two vertices C_1 and C_2 which is as follows:

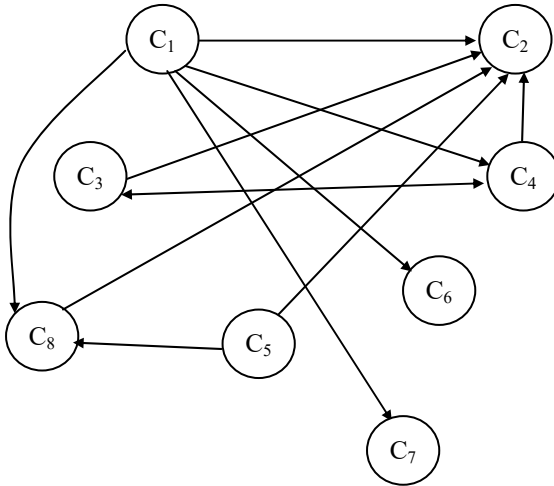

This merged graph acts as the merged matrix for the merged FCMs.

Now it may also so happen that three or more number of experts work on the same problem with a collection of attributes with only one common node.

They all use of same model viz the fuzzy cognitive maps models.

Then we see the merged model, which have that concept / node to be common and all other nodes of these three persons get related indirectly and the merged FCM model is formed.

We will first illustrate this situation by an example.

Let three experts work on the same problem and give the following three directed graphs.

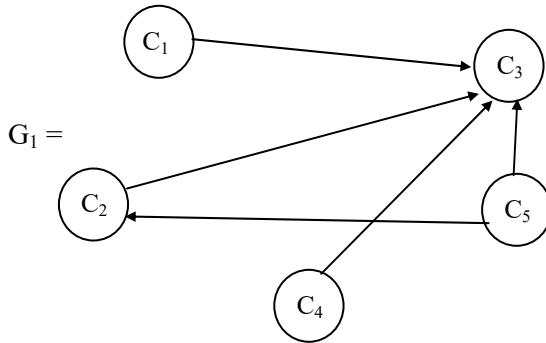

be the directed graph given by the first expert who wishes to work with the FCM model.

Let

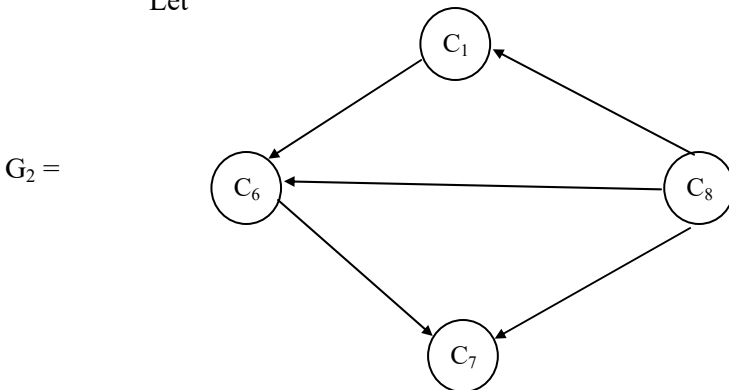

be the directed graph of the FCMs model given by the second expert.

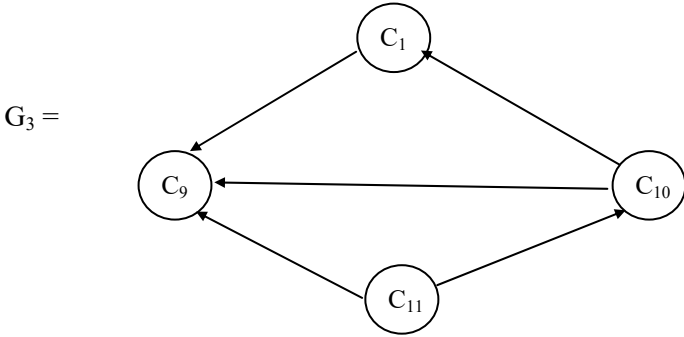

be the directed graph given by the third expert by using the FCMs model.

We can merge these three in only one way and obtain the merged graph G which is a pseudo lattice graph of type II.

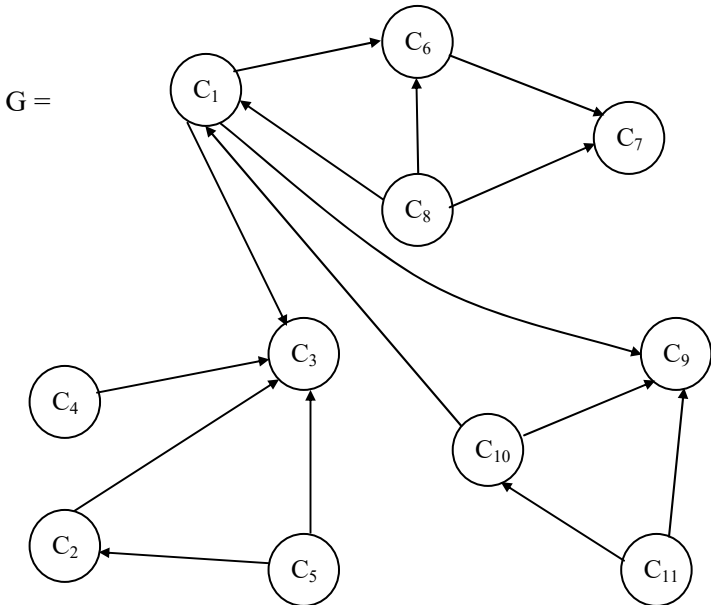

Now thus we have 11 attributes which are got after merging the common vertex C_1 in all the three of the graph G_1 , G_2 and G_3 .

The merged connection matrix M of the merged graph is as follows:

$$M = \begin{matrix} & c_1 & c_2 & c_3 & c_4 & c_5 & c_6 & c_7 & c_8 & c_9 & c_{10} & c_{11} \\ \begin{matrix} c_1 \\ c_2 \\ c_3 \\ c_4 \\ c_5 \\ c_6 \\ c_7 \\ c_8 \\ c_9 \\ c_{10} \\ c_{11} \end{matrix} & \begin{bmatrix} 0 & 0 & 1 & 0 & 0 & 1 & 0 & 0 & 1 & 0 & 0 \\ 0 & 0 & 1 & 0 & 0 & 0 & 0 & 0 & 0 & 0 & 0 \\ 0 & 0 & 0 & 0 & 0 & 0 & 0 & 0 & 0 & 0 & 0 \\ 0 & 0 & 1 & 0 & 0 & 0 & 0 & 0 & 0 & 0 & 0 \\ 0 & 1 & 1 & 0 & 0 & 0 & 0 & 0 & 0 & 0 & 0 \\ 0 & 0 & 0 & 0 & 0 & 0 & 1 & 0 & 0 & 0 & 0 \\ 0 & 0 & 0 & 0 & 0 & 0 & 0 & 0 & 0 & 0 & 0 \\ 1 & 0 & 0 & 0 & 0 & 1 & 1 & 0 & 0 & 0 & 0 \\ 0 & 0 & 0 & 0 & 0 & 0 & 0 & 0 & 0 & 0 & 0 \\ 1 & 0 & 0 & 0 & 0 & 0 & 0 & 0 & 1 & 0 & 0 \\ 0 & 0 & 0 & 0 & 0 & 0 & 0 & 0 & 1 & 1 & 0 \end{bmatrix} \end{matrix}.$$

Using the merged matrix M we can study merged FCMs model for which M is the merged dynamical system.

We can merge more number of vertices and get the FCMs which are merged.

We will still illustrate some other new type of merging.

Let G_1 , G_2 , G_3 and G_4 be the directed graphs given by four experts using FCM on the same problem.

Graph given by the first expert working with the nodes C_1 , C_2 , C_5 and C_6 .

Let $G_1 =$

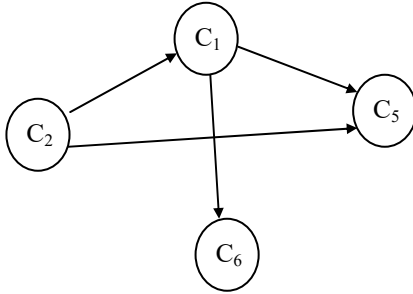

Let G_2 be the directed graph given by the second expert working on the same problem with the nodes C_2, C_3, C_4, C_9 and C_{10} .

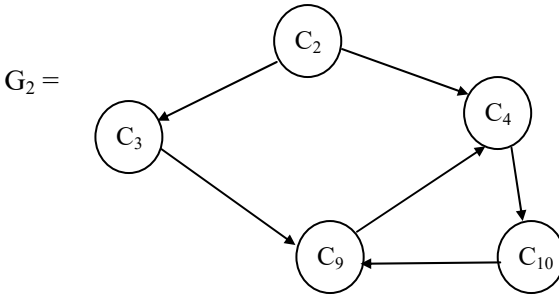

Let G_3 be the graph given by the third expert who works with nodes C_3, C_7, C_8 and C_{11} is as follows:

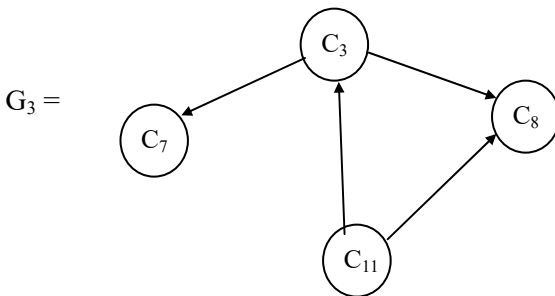

Finally the fourth expert works with the nodes C_7 , C_8 , C_{12} and C_{13} which is as follows:

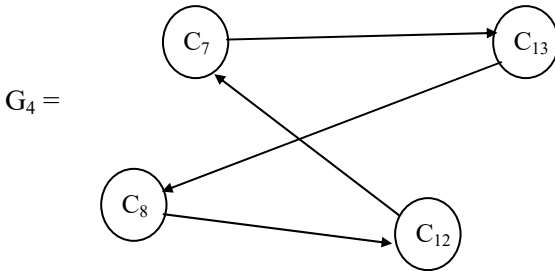

We can merge the four graphs only in the following way.

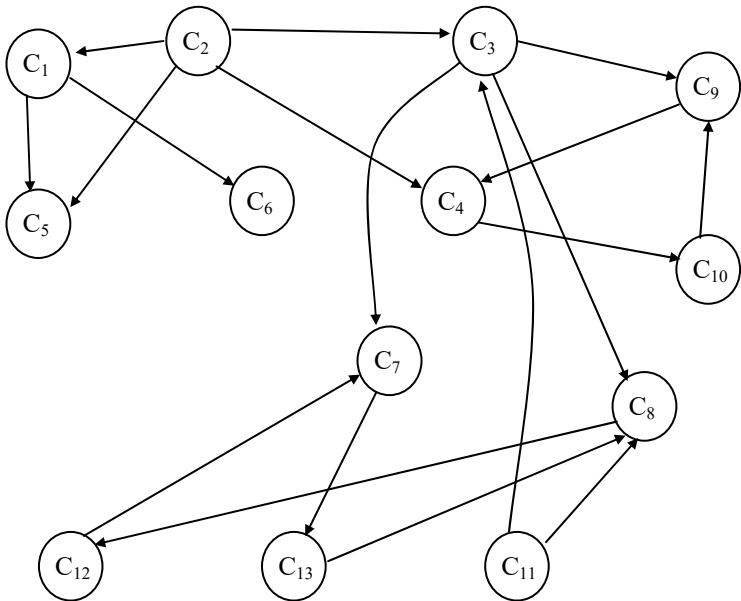

This G is finally the merged graphs of G_1 , G_2 , G_3 and G_4 .

So using 13 nodes four expert work on the problem they felt as relevant. However merged FCM gives the working model of the experts on the 13 nodes which saves time and economy.

Further no expert will feel he was not preferred or his expertise was not given equal importance. Only this merged FCMs alone can serve the best.

Now suppose two experts work on the same problem and they both also have a same pair of common nodes

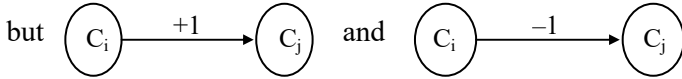

for the second and first expert respectively then we can merge C_i with C_i and C_j with C_j however the edge will be annulled.

Suppose on the other hand $C_i \rightarrow C_j$ and $C_i \leftarrow C_j$ then we merge as $C_i \leftrightarrow C_j$.

We will give some more illustrations of these types of merging. Suppose we have say 15 concepts C_1, C_2, \dots, C_{15} associated with the problem and all the experts wish to work with a selective number of nodes from these 15 nodes. We have four experts working on this problem and we see every expert has atleast one among the other four experts with a common node or edge or both in their directed graphs. All of them use the FCMs model and we get using these four experts directed graph and the merged FCM model is obtained.

Let G_1 be the directed graph of the FCM given by the first expert.

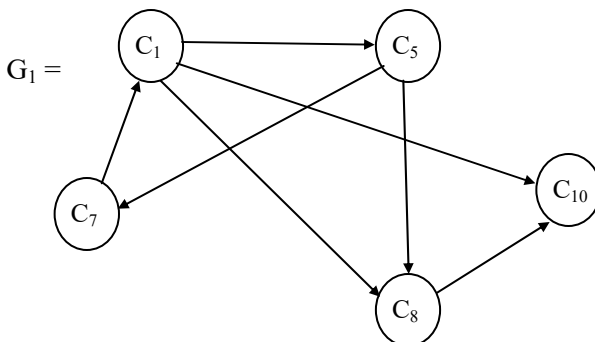

Let G_2 be the directed graph of FCMs given by the second expert.

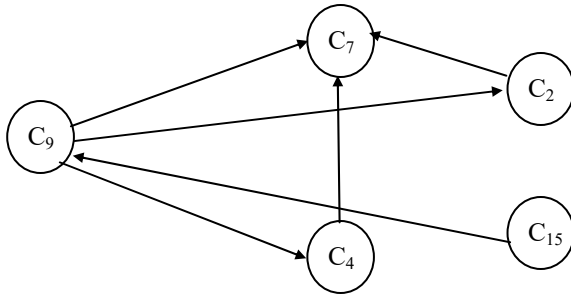

Let G_3 be the directed graph of the

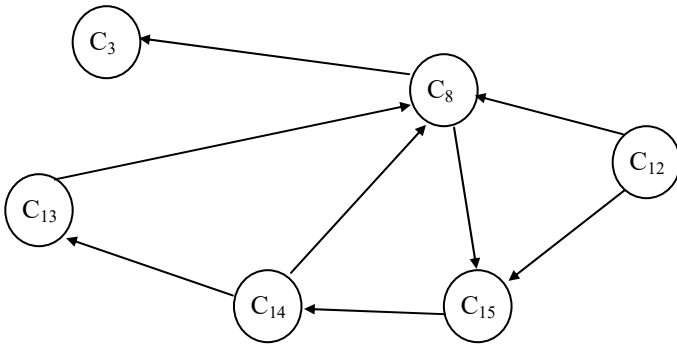

third expert.

Let G_4 be the directed graph of the FCM.

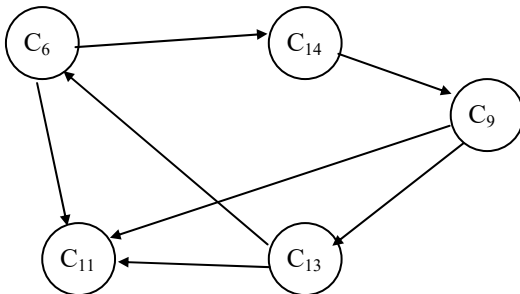

We can merge these four graphs appropriately and get at the final graph which is as follows:

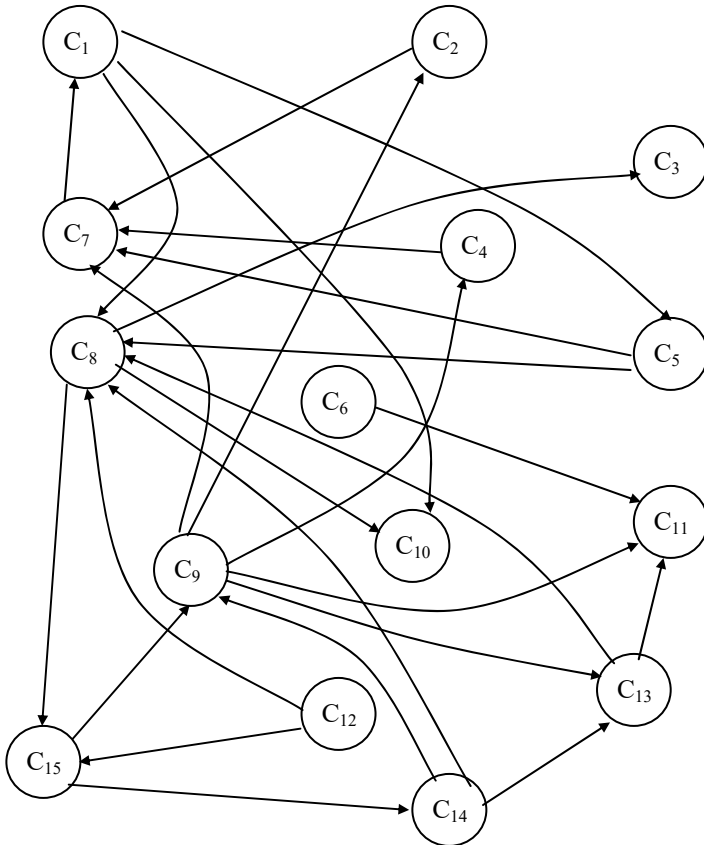

Merging of FCMs paves way for integrated study of the experts opinion. However merged FCMs model are different from combined FCMs model.

It is left as an open problem for the reader to give a program for getting a merged FCMs merged graph and the merged matrix in the analysis of a problem by several experts.

We will give illustrations of this concept.

However we wish to keep on record that these examples are only illustrations and we have not worked on any real model.

Example 2.6: Let $C_1, C_2, C_3, \dots, C_{12}$ be some 12 concepts related with a social problem.

3 experts work on the same problem using some of the concepts from C_1, C_2, \dots, C_{12} using the FCMs model.

Let G_1 be the directed graph given by the first expert who uses the concepts C_1, C_2, C_5, C_7, C_8 and C_9 .

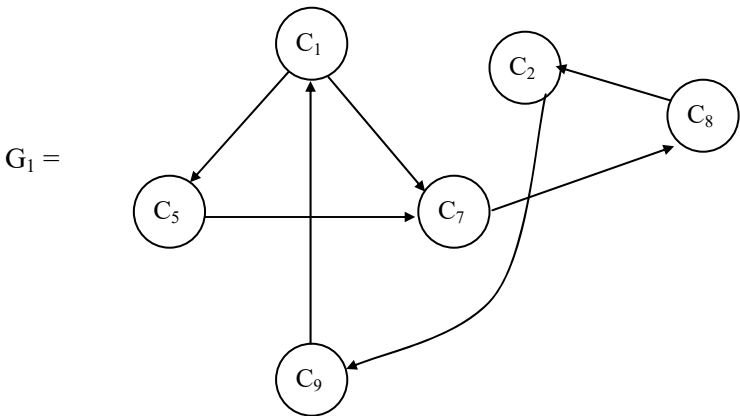

Let M_1 be the related connection matrix of the FCM given by the first expert.

$$M_1 = \begin{matrix} & c_1 & c_2 & c_5 & c_7 & c_8 & c_9 \\ \begin{matrix} c_1 \\ c_2 \\ c_5 \\ c_7 \\ c_8 \\ c_9 \end{matrix} & \begin{bmatrix} 0 & 0 & 1 & 1 & 0 & 0 \\ 0 & 0 & 0 & 0 & 0 & 1 \\ 0 & 0 & 0 & 1 & 0 & 0 \\ 0 & 0 & 0 & 0 & 1 & 0 \\ 0 & 1 & 0 & 0 & 0 & 0 \\ 1 & 0 & 0 & 0 & 0 & 0 \end{bmatrix} \end{matrix} .$$

Let G_2 be the graph given by the second expert. He works on the nodes c_1, c_3, c_7, c_8 and c_{10} .

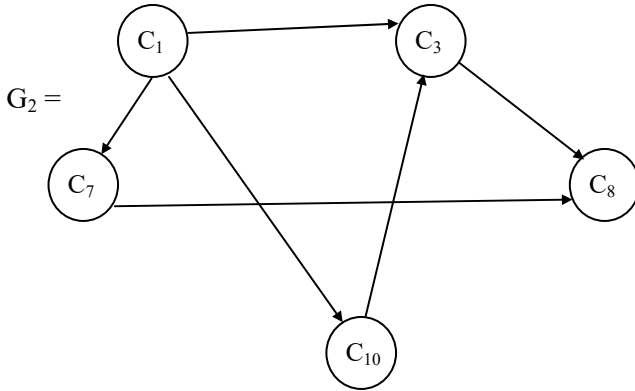

The connection matrix M_2 associated with the graph G_2 is as follows:

$$\begin{array}{c}
 c_1 \quad c_3 \quad c_7 \quad c_8 \quad c_{10} \\
 \begin{array}{l}
 c_1 \\
 c_3 \\
 c_7 \\
 c_8 \\
 c_{10}
 \end{array}
 \begin{bmatrix}
 0 & 1 & 1 & 0 & 1 \\
 0 & 0 & 0 & 1 & 0 \\
 0 & 0 & 0 & 1 & 0 \\
 0 & 0 & 0 & 0 & 0 \\
 0 & 1 & 0 & 0 & 0
 \end{bmatrix}
 \end{array}$$

Let G_3 be the graph given by the third expert who works with the nodes c_3, c_4, c_{10}, c_{11} and c_{12} .

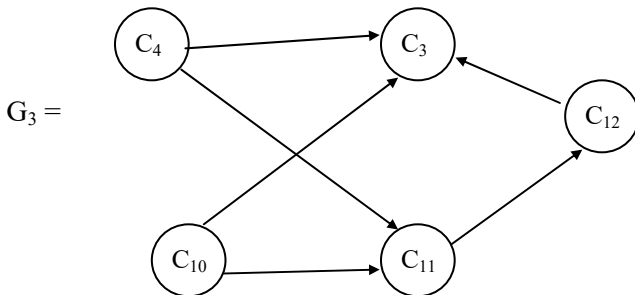

The connection matrix associated with this graph is as follows.

$$\begin{matrix}
 & c_3 & c_4 & c_{10} & c_{11} & c_{12} \\
 c_3 & \begin{bmatrix} 0 & 0 & 0 & 0 & 0 \end{bmatrix} \\
 c_4 & \begin{bmatrix} 1 & 0 & 0 & 1 & 0 \end{bmatrix} \\
 c_{10} & \begin{bmatrix} 1 & 0 & 0 & 1 & 0 \end{bmatrix} \\
 c_{11} & \begin{bmatrix} 0 & 0 & 0 & 0 & 1 \end{bmatrix} \\
 c_{12} & \begin{bmatrix} 1 & 0 & 0 & 0 & 0 \end{bmatrix}
 \end{matrix}$$

Now we get the unique merged graph of the three graphs G_1, G_2 and G_3 .

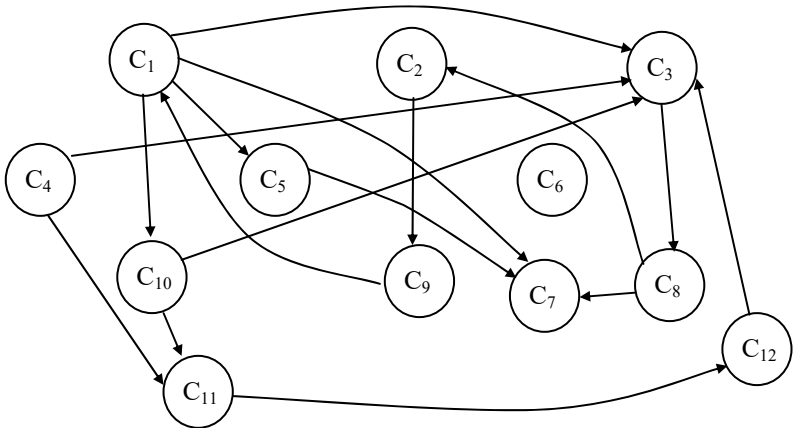

Now using this merged directed graph we get the merged connection matrix M which is as follows:

$$\begin{array}{c}
 c_1 \quad c_2 \quad c_3 \quad c_4 \quad c_5 \quad c_6 \quad c_7 \quad c_8 \quad c_9 \quad c_{10} \quad c_{11} \quad c_{12} \\
 \begin{array}{l}
 c_1 \\
 c_2 \\
 c_3 \\
 c_4 \\
 c_5 \\
 c_6 \\
 c_7 \\
 c_8 \\
 c_9 \\
 c_{10} \\
 c_{11} \\
 c_{12}
 \end{array}
 \left[\begin{array}{cccccccccccc}
 0 & 0 & 1 & 0 & 1 & 0 & 1 & 0 & 0 & 1 & 0 & 0 \\
 0 & 0 & 0 & 0 & 0 & 0 & 0 & 0 & 1 & 0 & 0 & 0 \\
 0 & 0 & 0 & 0 & 0 & 0 & 0 & 1 & 0 & 0 & 0 & 0 \\
 0 & 0 & 1 & 0 & 0 & 0 & 0 & 0 & 0 & 0 & 1 & 0 \\
 0 & 0 & 0 & 0 & 0 & 0 & 1 & 0 & 0 & 0 & 0 & 0 \\
 0 & 0 & 0 & 0 & 0 & 0 & 0 & 0 & 0 & 0 & 0 & 0 \\
 0 & 0 & 0 & 0 & 0 & 0 & 0 & 1 & 0 & 0 & 0 & 0 \\
 0 & 1 & 0 & 0 & 0 & 0 & 0 & 0 & 0 & 0 & 0 & 0 \\
 1 & 0 & 0 & 0 & 0 & 0 & 0 & 0 & 0 & 0 & 0 & 0 \\
 0 & 0 & 1 & 0 & 0 & 0 & 0 & 0 & 0 & 0 & 1 & 0 \\
 0 & 0 & 0 & 0 & 0 & 0 & 0 & 0 & 0 & 0 & 0 & 1 \\
 0 & 0 & 1 & 0 & 0 & 0 & 0 & 0 & 0 & 0 & 0 & 0
 \end{array} \right] .
 \end{array}$$

Note: We use at times capital C_i 's and at times small c_i but both mean the same, easily followed from the context.

This M serves as the connection matrix or the dynamical system of the merged FCM.

The concept of merged FCMs play a vital role in the study of FCMs using multi experts opinion with certain conditions imposed on the concepts used by them.

If in the FCMs the concepts are so tailored (that is attributes / nodes without changing the notion they carry) we can always make the directed graph to have weights 0 and 1 only we assume -1 does not occur as a weight of the directed graph. This is so conditioned so as to make while merging or while adding the matrices they do not cancel out. Further they are different from the overlapping FCMs and NCMs developed by the authors in [76]. These are different and they give equal importance to each and every expert and the merged matrix also contains only entries from 0 and 1.

Another flexibility of the merged FCMs is if we have c_1, \dots, c_n number of attributes and say some t expert work with them. One expert can work with r_1 attributes, another say r_2 attributes and so on and the researcher who works with problem can work with these t FCMs models if he is interested in getting t -bunch of opinions.

These r_1, r_2, \dots, r_t sets of attributes are such that any set of r_i and r_j attributes have a common attribute or attributes for each $1 \leq i, j \leq t$. So if the expert wishes to work with only two set of attributes from two experts he can do so. Likewise one can choose to get the merged matrix with 2 experts or 3 experts to 4 experts or so on say upto s experts $s \leq t$.

We will describe this with examples.

However the authors make it clear to the readers this illustration is not a product of working with any of the problems only an example to show how the merged FCMs functions and nothing more.

Example 2.7: Let $c_1, c_2, c_3, \dots, c_{12}$ be 12 attributes or nodes of a problem. Suppose 4 experts wish to work on it using only FCMs model. Further the experts do not work with all the 12 concepts only a few of the concepts from the 12 concepts. However each expert has a common concept with the other three experts. The directed graphs given by the four experts are as follows:

Suppose expert 1 works with the nodes c_1, c_2, c_7, c_{10} and c_{11} . Expert 2 prefers to work with the nodes $c_5, c_7, c_{10}, c_4, c_{12}$. Expert 3 works with the nodes c_1, c_2, c_5 and c_9 and expert four work with $c_3, c_6, c_8, c_{10}, c_{12}$ and c_9 . We see experts, 1 and 2 have the common nodes $\{c_{10}, c_7\}$.

Experts 1 and 3 have the common nodes $\{c_1, c_2\}$.

Experts 1 and 4 have $\{c_{10}\}$ to be the common node.

Experts 2 and 3 have $\{c_5\}$ to be the common node.

Experts 2 and 4 have $\{c_{10}\}$ to be the common node.

Experts 3 and 4 have $\{c_9\}$ to be the common node.

Thus the first criteria of having common attributes / nodes between any two experts are satisfied.

Now the researcher or problem solver may like to study the expert opinion in twos or threes or all the four. All these situations will be described.

Now the directed graph given by the four experts and the related connection matrices are given in the following.

The directed graph given by the first expert is

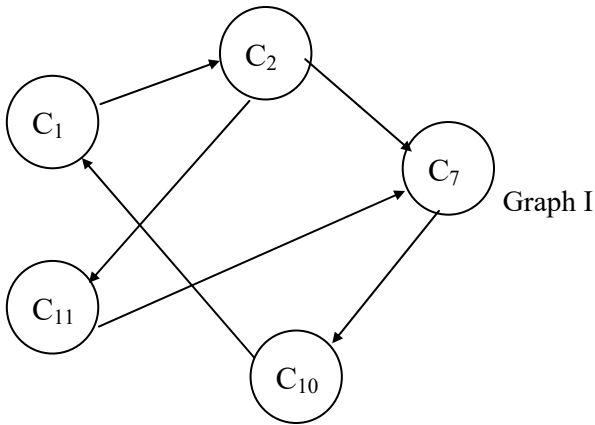

The connection matrix M_1 of graph I is as follows:

$$M_1 = \begin{matrix} & c_1 & c_2 & c_7 & c_{10} & c_{11} \\ \begin{matrix} c_1 \\ c_2 \\ c_7 \\ c_{10} \\ c_{11} \end{matrix} & \begin{bmatrix} 0 & 1 & 0 & 0 & 0 \\ 0 & 0 & 1 & 0 & 1 \\ 0 & 0 & 0 & 1 & 0 \\ 1 & 0 & 0 & 0 & 0 \\ 0 & 0 & 1 & 0 & 0 \end{bmatrix} \end{matrix} .$$

The directed graph given by the second expert is as follows:

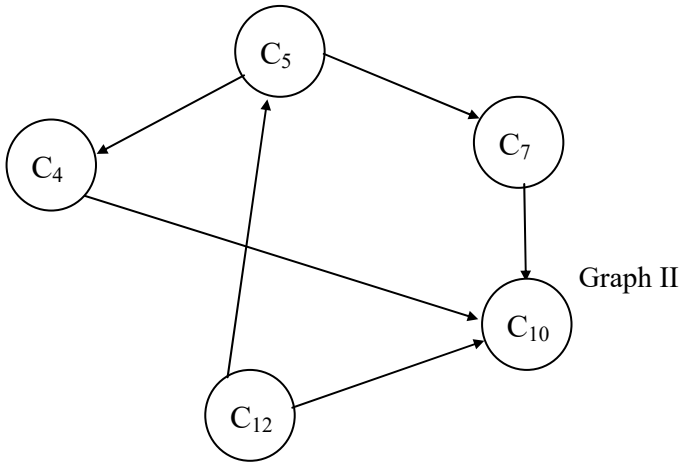

The connection matrix M_2 associated with the directed graph of second expert using graph II is as follows:

$$M_2 = \begin{matrix} & c_4 & c_5 & c_7 & c_{10} & c_{12} \\ \begin{matrix} c_4 \\ c_5 \\ c_7 \\ c_{10} \\ c_{12} \end{matrix} & \begin{bmatrix} 0 & 0 & 0 & 1 & 0 \\ 1 & 0 & 1 & 0 & 0 \\ 0 & 0 & 0 & 1 & 0 \\ 0 & 0 & 0 & 0 & 0 \\ 0 & 1 & 0 & 1 & 0 \end{bmatrix} \end{matrix} .$$

The directed graph given by the third expert is as follows:

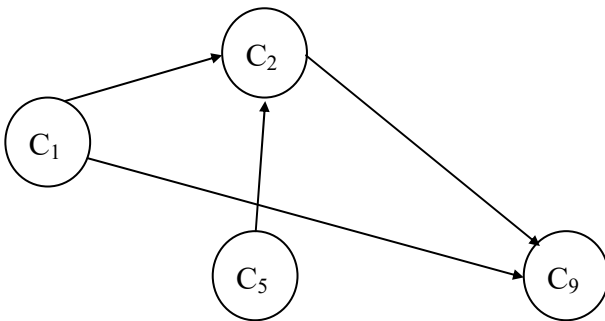

The connection matrix M_3 associated with the directed graph III of the 3rd expert is as follows:

$$M_3 = \begin{matrix} & c_1 & c_2 & c_5 & c_9 \\ \begin{matrix} c_1 \\ c_2 \\ c_5 \\ c_9 \end{matrix} & \begin{bmatrix} 0 & 1 & 0 & 1 \\ 0 & 0 & 0 & 1 \\ 0 & 1 & 0 & 0 \\ 0 & 0 & 0 & 0 \end{bmatrix} \end{matrix}.$$

The directed graph given by the fourth expert is as follows:

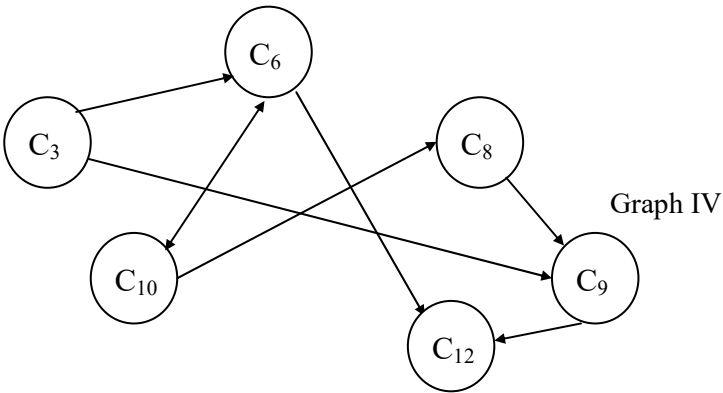

The related connection matrix of the graph IV is as follows:

$$M_4 = \begin{matrix} & c_3 & c_6 & c_8 & c_9 & c_{10} & c_{12} \\ \begin{matrix} c_3 \\ c_6 \\ c_8 \\ c_9 \\ c_{10} \\ c_{12} \end{matrix} & \begin{bmatrix} 0 & 1 & 0 & 1 & 0 & 0 \\ 0 & 0 & 0 & 0 & 1 & 1 \\ 0 & 0 & 0 & 1 & 0 & 0 \\ 0 & 0 & 0 & 0 & 0 & 1 \\ 0 & 1 & 1 & 0 & 0 & 0 \\ 0 & 0 & 0 & 0 & 0 & 0 \end{bmatrix} \end{matrix}.$$

Now we get the merged FCM of experts 1 and 2 is given in the following.

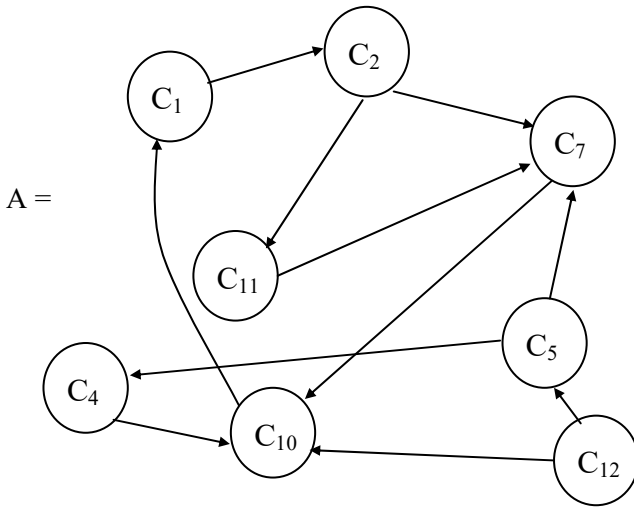

The merged graph of graph I and graph II of the FCMs of experts 1 and 2 is denoted by A. The related connection matrix M_A is as follows.

$$M_A = \begin{matrix} & c_1 & c_2 & c_4 & c_5 & c_7 & c_{10} & c_{11} & c_{12} \\ \begin{matrix} c_1 \\ c_2 \\ c_4 \\ c_5 \\ c_7 \\ c_{10} \\ c_{11} \\ c_{12} \end{matrix} & \begin{bmatrix} 0 & 1 & 0 & 0 & 0 & 0 & 0 & 0 & 0 \\ 0 & 0 & 0 & 0 & 1 & 0 & 1 & 0 & 0 \\ 0 & 0 & 0 & 0 & 0 & 1 & 0 & 0 & 0 \\ 0 & 0 & 1 & 0 & 1 & 0 & 0 & 0 & 0 \\ 0 & 0 & 0 & 0 & 0 & 1 & 0 & 0 & 0 \\ 1 & 0 & 0 & 0 & 0 & 0 & 0 & 0 & 0 \\ 0 & 0 & 0 & 0 & 1 & 0 & 0 & 0 & 0 \\ 0 & 0 & 0 & 1 & 0 & 1 & 0 & 0 & 0 \end{bmatrix} & . \end{matrix}$$

M_A serves as the merged dynamical system of the merged FCMs of the experts 1 and 2. Using M_A one can study the problem for the 8 attributes.

Suppose some wants to study the experts opinion of 1 and 3 alone. Then we merge the graph I and III of the FCMs given by the experts 1 and 3. Let B denote the merged graph of the two FCMs which is as follows:

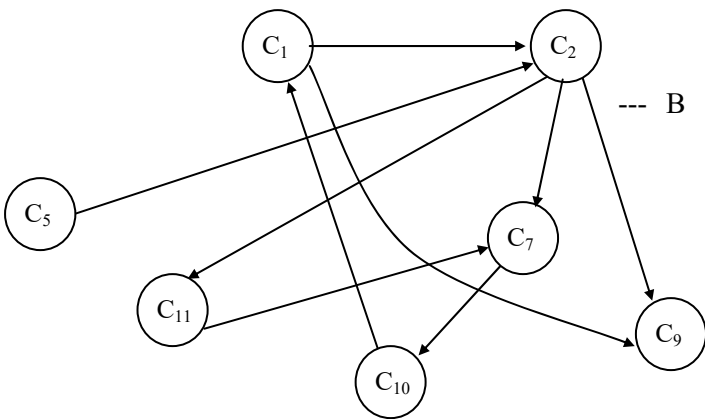

Using the merged graph B we obtain the merged FCMs merged connection matrix which is denoted by M_B .

$$M_B = \begin{matrix} & \begin{matrix} c_1 & c_2 & c_5 & c_7 & c_9 & c_{10} & c_{11} \end{matrix} \\ \begin{matrix} c_1 \\ c_2 \\ c_5 \\ c_7 \\ c_9 \\ c_{10} \\ c_{11} \end{matrix} & \begin{bmatrix} 0 & 1 & 0 & 0 & 1 & 0 & 0 \\ 0 & 0 & 0 & 1 & 1 & 0 & 1 \\ 0 & 1 & 0 & 0 & 0 & 0 & 0 \\ 0 & 0 & 0 & 0 & 0 & 1 & 0 \\ 0 & 0 & 0 & 0 & 0 & 0 & 0 \\ 1 & 0 & 0 & 0 & 0 & 0 & 0 \\ 0 & 0 & 0 & 1 & 0 & 0 & 0 \end{bmatrix} \end{matrix} .$$

We get the merged opinion of the two experts 2 and 3. The merged directed graph of the experts 2 and 3 be denoted by D which is as follows:

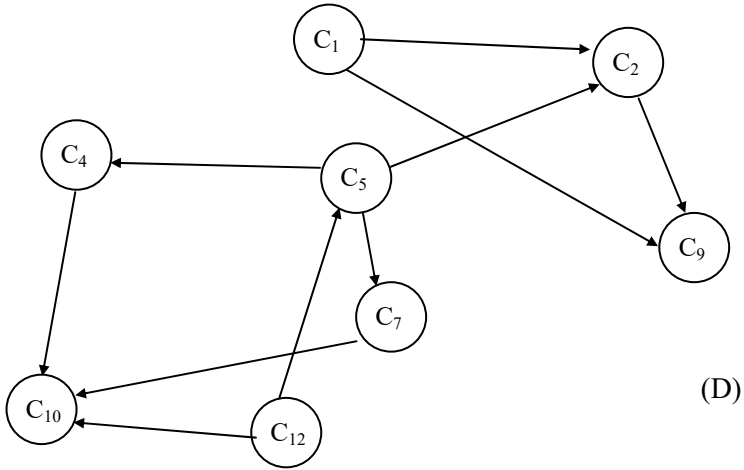

The merged matrix of the merged graph D is as follows:

$$M_D = \begin{matrix} & c_1 & c_2 & c_4 & c_5 & c_7 & c_9 & c_{10} & c_{12} \\ \begin{matrix} c_1 \\ c_2 \\ c_4 \\ c_5 \\ c_7 \\ c_9 \\ c_{10} \\ c_{12} \end{matrix} & \begin{bmatrix} 0 & 1 & 0 & 0 & 0 & 1 & 0 & 0 \\ 0 & 0 & 0 & 0 & 0 & 1 & 0 & 0 \\ 0 & 0 & 0 & 0 & 0 & 0 & 1 & 0 \\ 0 & 1 & 1 & 0 & 1 & 0 & 0 & 0 \\ 0 & 0 & 0 & 0 & 0 & 0 & 1 & 0 \\ 0 & 0 & 0 & 0 & 0 & 0 & 0 & 0 \\ 0 & 0 & 0 & 0 & 0 & 0 & 0 & 0 \\ 0 & 0 & 0 & 1 & 0 & 0 & 1 & 0 \end{bmatrix} \end{matrix} .$$

Using the merged connection matrix M_D we can use it as the merged FCMs dynamical system of the two experts 2 and 3.

Now we give the merged directed graph E of the experts 2 and 4 which is as follows:

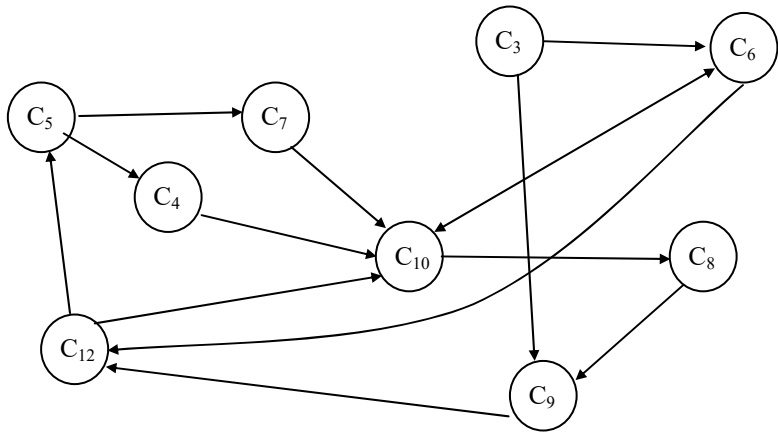

(E)

The merged connection matrix M_E of the merged directed graph E is as follows:

$$M_E = \begin{matrix} & \begin{matrix} c_3 & c_4 & c_5 & c_6 & c_7 & c_8 & c_9 & c_{10} & c_{12} \end{matrix} \\ \begin{matrix} c_3 \\ c_4 \\ c_5 \\ c_6 \\ c_7 \\ c_8 \\ c_9 \\ c_{10} \\ c_{12} \end{matrix} & \begin{bmatrix} 0 & 0 & 0 & 1 & 0 & 0 & 1 & 0 & 0 \\ 0 & 0 & 0 & 0 & 0 & 0 & 0 & 1 & 0 \\ 0 & 1 & 0 & 0 & 1 & 0 & 0 & 0 & 0 \\ 0 & 0 & 0 & 0 & 0 & 0 & 0 & 1 & 1 \\ 0 & 0 & 0 & 0 & 0 & 0 & 0 & 1 & 0 \\ 0 & 0 & 0 & 0 & 0 & 0 & 1 & 0 & 0 \\ 0 & 0 & 0 & 0 & 0 & 0 & 0 & 0 & 1 \\ 0 & 0 & 0 & 1 & 0 & 1 & 0 & 0 & 0 \\ 0 & 0 & 1 & 0 & 0 & 0 & 0 & 1 & 0 \end{bmatrix} \end{matrix} .$$

Using M_F as the merged FCMs dynamical system we can get the opinion.

Now we can merge the opinion of three of the experts 1, 2, and 3. We can get the merged graph G of the three experts which is as follows:

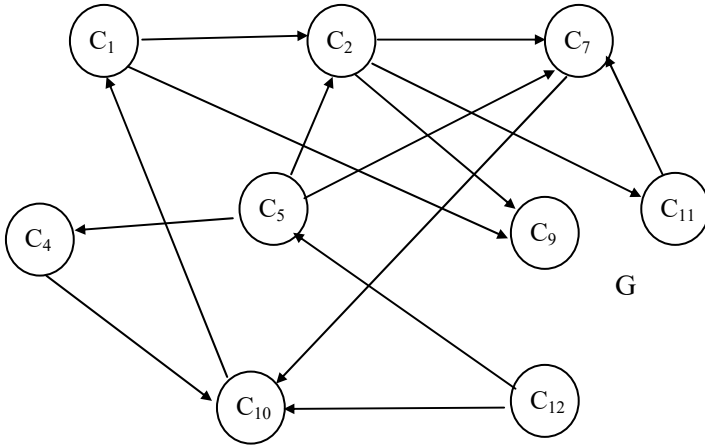

Let M_G be the connection matrix related with the merged graph G .

$$M_G = \begin{matrix} & \begin{matrix} c_1 & c_2 & c_4 & c_5 & c_7 & c_9 & c_{10} & c_{11} & c_{12} \end{matrix} \\ \begin{matrix} c_1 \\ c_2 \\ c_4 \\ c_5 \\ c_7 \\ c_9 \\ c_{10} \\ c_{11} \\ c_{12} \end{matrix} & \begin{bmatrix} 0 & 1 & 0 & 0 & 0 & 1 & 0 & 0 & 0 \\ 0 & 0 & 0 & 0 & 1 & 1 & 0 & 1 & 0 \\ 0 & 0 & 0 & 0 & 0 & 0 & 1 & 0 & 0 \\ 0 & 1 & 1 & 0 & 1 & 0 & 0 & 0 & 0 \\ 0 & 0 & 0 & 0 & 0 & 0 & 1 & 0 & 0 \\ 0 & 0 & 0 & 0 & 0 & 0 & 0 & 0 & 0 \\ 1 & 0 & 0 & 0 & 0 & 0 & 0 & 0 & 0 \\ 0 & 0 & 0 & 0 & 1 & 0 & 0 & 0 & 0 \\ 0 & 0 & 0 & 1 & 0 & 0 & 1 & 0 & 0 \end{bmatrix} \end{matrix} .$$

Using M_G we can get the opinion of the three experts at a time.

Now let us get the merged graph of the three experts 1, 2 and 4. Let H be the related merged graph.

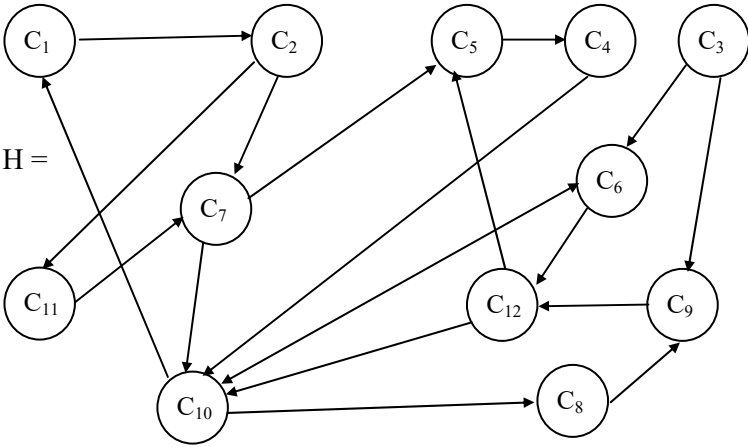

Let M_H be the related connection matrix of the merged graph H of the three experts 1, 2 and 4. We have the following merged matrix M_H .

$$M_H = \begin{matrix} & \begin{matrix} c_1 & c_2 & c_3 & c_4 & c_5 & c_6 & c_7 & c_8 & c_9 & c_{10} & c_{11} & c_{12} \end{matrix} \\ \begin{matrix} c_1 \\ c_2 \\ c_3 \\ c_4 \\ c_5 \\ c_6 \\ c_7 \\ c_8 \\ c_9 \\ c_{10} \\ c_{11} \\ c_{12} \end{matrix} & \begin{bmatrix} 0 & 1 & 0 & 0 & 0 & 0 & 0 & 0 & 0 & 0 & 0 & 0 \\ 0 & 0 & 0 & 0 & 0 & 0 & 1 & 0 & 0 & 0 & 1 & 0 \\ 0 & 0 & 0 & 0 & 0 & 1 & 0 & 0 & 1 & 0 & 0 & 0 \\ 0 & 0 & 0 & 0 & 0 & 0 & 0 & 0 & 0 & 1 & 0 & 0 \\ 0 & 0 & 0 & 1 & 0 & 0 & 0 & 0 & 0 & 0 & 0 & 0 \\ 0 & 0 & 0 & 0 & 0 & 0 & 0 & 0 & 0 & 1 & 0 & 1 \\ 0 & 0 & 0 & 0 & 1 & 0 & 0 & 0 & 0 & 1 & 0 & 0 \\ 0 & 0 & 0 & 0 & 0 & 0 & 0 & 0 & 1 & 0 & 0 & 0 \\ 0 & 0 & 0 & 0 & 0 & 0 & 0 & 0 & 0 & 0 & 0 & 1 \\ 1 & 0 & 0 & 0 & 0 & 0 & 1 & 0 & 0 & 0 & 0 & 0 \\ 0 & 0 & 0 & 0 & 0 & 0 & 1 & 0 & 0 & 0 & 0 & 0 \\ 0 & 0 & 0 & 0 & 1 & 0 & 0 & 0 & 0 & 1 & 0 & 0 \end{bmatrix} \end{matrix} .$$

M_I is the merged matrix of the merged FCMs of the three experts 1, 3 and 4. Let J be the merged graph of the three experts 2, 3 and 4 which is as follows.

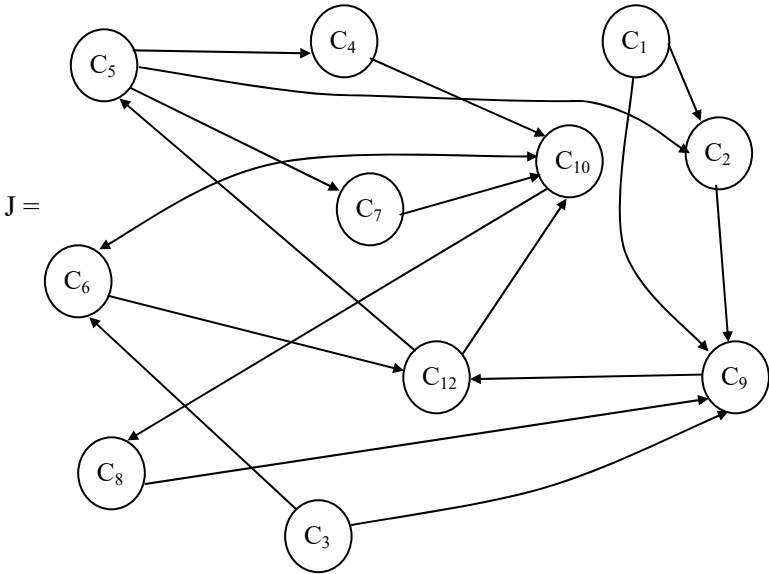

Let M_J be the merged connection matrix of the merged graph J of the three experts 2, 3 and 4.

$$M_J = \begin{matrix} & \begin{matrix} c_1 & c_2 & c_3 & c_4 & c_5 & c_6 & c_7 & c_8 & c_9 & c_{10} & c_{12} \end{matrix} \\ \begin{matrix} c_1 \\ c_2 \\ c_3 \\ c_4 \\ c_5 \\ c_6 \\ c_7 \\ c_8 \\ c_9 \\ c_{10} \\ c_{12} \end{matrix} & \begin{bmatrix} 0 & 1 & 0 & 0 & 0 & 0 & 0 & 0 & 1 & 0 & 0 \\ 0 & 0 & 0 & 0 & 0 & 0 & 0 & 0 & 1 & 0 & 0 \\ 0 & 0 & 0 & 0 & 0 & 1 & 0 & 0 & 1 & 0 & 0 \\ 0 & 0 & 0 & 0 & 0 & 0 & 0 & 0 & 0 & 1 & 0 \\ 0 & 1 & 0 & 1 & 0 & 0 & 1 & 0 & 0 & 0 & 0 \\ 0 & 0 & 0 & 0 & 0 & 0 & 0 & 0 & 0 & 1 & 1 \\ 0 & 0 & 0 & 0 & 0 & 0 & 0 & 0 & 0 & 1 & 0 \\ 0 & 0 & 0 & 0 & 0 & 0 & 0 & 0 & 1 & 0 & 0 \\ 0 & 0 & 0 & 0 & 0 & 0 & 0 & 0 & 0 & 0 & 1 \\ 0 & 0 & 0 & 0 & 0 & 1 & 0 & 1 & 0 & 0 & 0 \\ 0 & 0 & 0 & 0 & 1 & 0 & 0 & 0 & 0 & 1 & 0 \end{bmatrix} \end{matrix} .$$

We see M_K and M_H are different graphs and the resultant also may not be the same for any initial state vector. For the merged graph M_K contains all the merged graphs and the graphs I, II, III and IV.

This is the way the merged graphs of any t experts who have non empty intersection of any two concepts associated with the experts works.

Another type of merging is as follows:

Let C_1, C_2, \dots, C_n be n concepts associated with the problem. Suppose t experts wishes to work with the problem taking a few of the attributes using the FCMs model.

Suppose the t experts work with this problem we see as in the earlier case no two experts need to have the non empty intersection of the attribute set; what we demand is every expert has only with two other expert the non empty intersection of the attributes selected by them. Further two of the experts have only one expert who has a non empty intersection with the attributes.

For better understanding we give the following example. Further this type of choice of attributes can also occur for always one cannot demand every expert to choose the attributes in such a way that the attributes set intersect giving a non empty set.

Example 2.8: Let $C_1, C_2, C_3, C_4, \dots, C_{11}$ be the 11 attributes associated with the problem where four experts choose to work with a selected set of attributes from C_1, \dots, C_{11} using the FCMs model.

Let E_1, E_2, E_3 and E_4 be the four experts who work with the problem using attributes from the set $\{C_1, C_2, \dots, C_{11}\}$. The expert E_1 works with the attributes $\{C_1, C_2, C_7, C_8\}$.

The expert E_2 works with the attributes $\{C_7, C_8, C_4, C_5, C_{10}\}$. The expert E_3 works with the attributes $\{C_4, C_5, C_6, C_{11}\}$. The expert E_4 works with the attributes $\{C_6, C_{11}, C_9, C_3\}$.

We see the experts E_1 and E_2 have

$$\{C_7, C_8\} = \{C_1, C_2, C_7, C_8\} \cap \{C_7, C_8, C_5, C_4, C_{10}\}.$$

The experts $E_1 \cap E_3 = \phi$, $E_1 \cap E_4 = \phi$,

$$E_2 \cap E_3 = \{C_4, C_5, C_7, C_8, C_{10}\} \cap \{C_4, C_5, C_6, C_{11}\} = \{C_4, C_5\}.$$

$E_2 \cap E_4 = \phi$ (Here we use $E_i \cap E_j$ to represent the intersection of the sets of attributes used by experts E_i and E_j).

$$E_3 \cap E_4 = \{C_4, C_5, C_6, C_{11}\} \cap \{C_3, C_6, C_{11}, C_9\} = \{C_6, C_{11}\}.$$

This sort of choice of attributes by experts will be called as chain like merging and the resultant merged graphs will be known as chain like merged graph and the corresponding matrices as chain like merged matrix. Finally the merged FCMs will be known as chain like merged FCMs.

As in case of merged FCMs we cannot merge any of the two experts.

Here we can get the merged graphs of experts E_1 with E_2 , E_2 with E_3 and E_3 with E_4 and merged graphs of E_1, E_2 and E_3 or E_2, E_3 and E_4 and E_1, E_2, E_3 and E_4 .

Let us exhibit the directed graph given by the first expert E_1 and denote it by A .

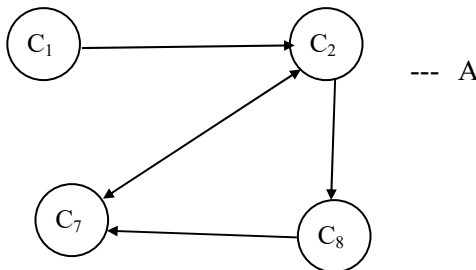

The connection matrix A associated with the directed graph A is as follows:

$$M_A = \begin{matrix} & C_1 & C_2 & C_7 & C_8 \\ \begin{matrix} C_1 \\ C_2 \\ C_7 \\ C_8 \end{matrix} & \begin{bmatrix} 0 & 1 & 0 & 0 \\ 0 & 0 & 1 & 1 \\ 0 & 1 & 0 & 0 \\ 0 & 0 & 1 & 0 \end{bmatrix} \end{matrix}$$

Let B be the directed graph given by the expert E₂.

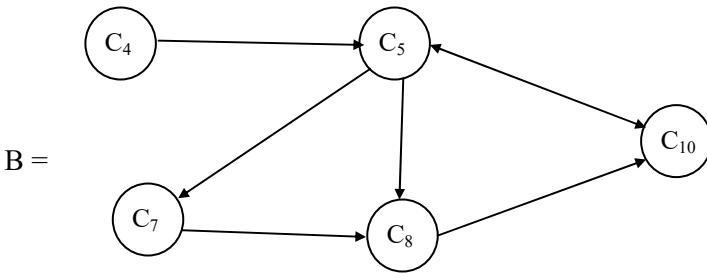

Let M_B be the connection matrix of the directed graph.

$$M_B = \begin{matrix} & C_4 & C_5 & C_7 & C_8 & C_{10} \\ \begin{matrix} C_4 \\ C_5 \\ C_7 \\ C_8 \\ C_{10} \end{matrix} & \begin{bmatrix} 0 & 1 & 0 & 0 & 0 \\ 0 & 0 & 1 & 1 & 1 \\ 0 & 0 & 0 & 1 & 0 \\ 0 & 0 & 0 & 0 & 1 \\ 0 & 1 & 0 & 0 & 0 \end{bmatrix} \end{matrix}.$$

Let C be the directed graph given by the third expert E₃.

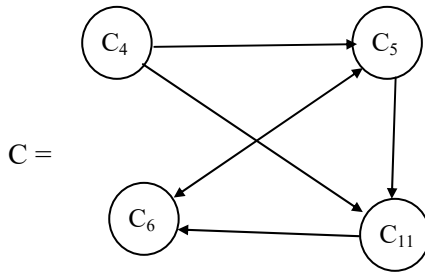

The connection matrix M_C associated with the directed graph C is as follows:

$$M_c = \begin{matrix} & C_4 & C_5 & C_6 & C_{11} \\ C_4 & \begin{bmatrix} 0 & 1 & 0 & 1 \end{bmatrix} \\ C_5 & \begin{bmatrix} 0 & 0 & 1 & 1 \end{bmatrix} \\ C_6 & \begin{bmatrix} 0 & 1 & 0 & 0 \end{bmatrix} \\ C_{11} & \begin{bmatrix} 0 & 0 & 1 & 0 \end{bmatrix} \end{matrix}.$$

Let D be the directed graph given by the fourth expert.

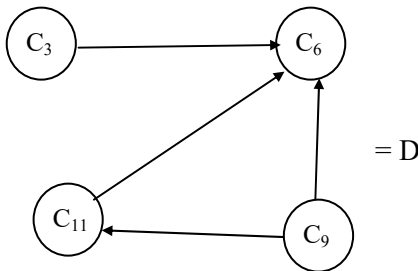

The connection matrix M_D associated with graph D is as follows.

$$M_D = \begin{matrix} & C_3 & C_6 & C_9 & C_{11} \\ C_3 & \begin{bmatrix} 0 & 1 & 0 & 0 \end{bmatrix} \\ C_6 & \begin{bmatrix} 0 & 0 & 0 & 0 \end{bmatrix} \\ C_9 & \begin{bmatrix} 0 & 1 & 0 & 1 \end{bmatrix} \\ C_{11} & \begin{bmatrix} 0 & 1 & 0 & 0 \end{bmatrix} \end{matrix}.$$

We have no option of merging E_3 and E_4 .

The only option is E_1 can be merged with E_2 . The merged graph of A and B of the experts E_1 and E_2 is as follows. Let E be the directed merged graph of A and B.

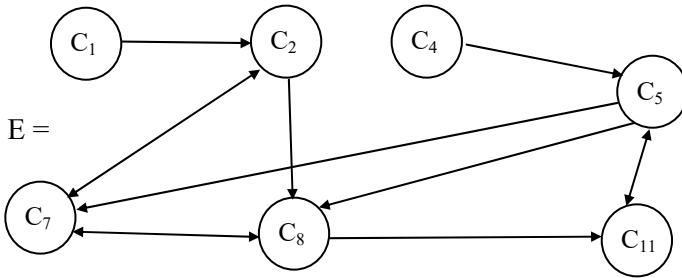

The merged connection matrix of the merged directed graph E is denoted by M_E which is as follows:

$$M_E = \begin{matrix} & c_1 & c_2 & c_4 & c_5 & c_7 & c_8 & c_{11} \\ c_1 & \begin{bmatrix} 0 & 1 & 0 & 0 & 0 & 0 & 0 \end{bmatrix} \\ c_2 & \begin{bmatrix} 0 & 0 & 0 & 0 & 1 & 1 & 0 \end{bmatrix} \\ c_4 & \begin{bmatrix} 0 & 0 & 0 & 1 & 0 & 0 & 0 \end{bmatrix} \\ c_5 & \begin{bmatrix} 0 & 0 & 0 & 0 & 1 & 1 & 1 \end{bmatrix} \\ c_7 & \begin{bmatrix} 0 & 1 & 0 & 0 & 0 & 1 & 0 \end{bmatrix} \\ c_8 & \begin{bmatrix} 0 & 0 & 0 & 0 & 1 & 0 & 1 \end{bmatrix} \\ c_{11} & \begin{bmatrix} 0 & 0 & 0 & 1 & 0 & 0 & 0 \end{bmatrix} \end{matrix}.$$

Now we merge the directed graphs B and C of experts E_2 and E_3 which is as follows:

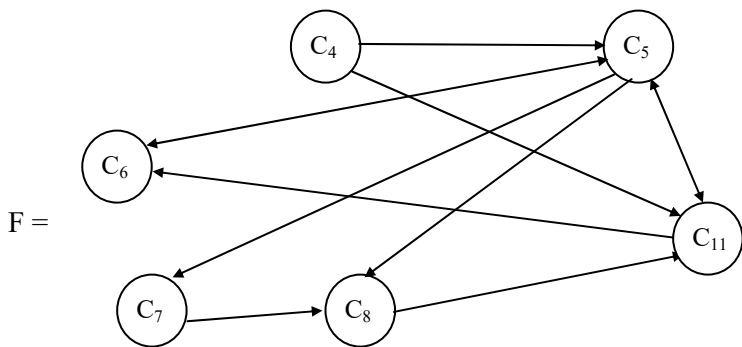

Let us denote the merged graph by F.

The connection merged matrix of M_F of F is as follows:

$$M_F = \begin{matrix} & c_4 & c_5 & c_6 & c_7 & c_8 & c_{11} \\ \begin{matrix} c_4 \\ c_5 \\ c_6 \\ c_7 \\ c_8 \\ c_{11} \end{matrix} & \begin{bmatrix} 0 & 1 & 0 & 0 & 0 & 1 \\ 0 & 0 & 1 & 1 & 1 & 1 \\ 0 & 1 & 0 & 0 & 0 & 0 \\ 0 & 0 & 0 & 0 & 1 & 0 \\ 0 & 0 & 0 & 0 & 0 & 1 \\ 0 & 1 & 1 & 0 & 0 & 0 \end{bmatrix} \end{matrix} .$$

Now we can merge the directed graph C with that of D and get the merged directed graph G which is as follows:

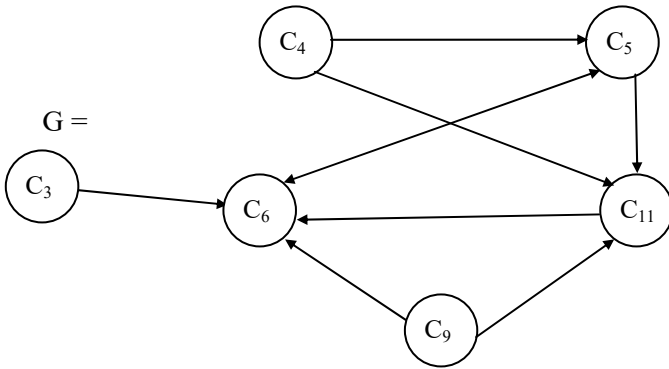

The connection merged matrix M_G of the merged graph G is as follows:

$$M_G = \begin{matrix} & c_3 & c_4 & c_5 & c_6 & c_9 & c_{11} \\ \begin{matrix} c_3 \\ c_4 \\ c_5 \\ c_6 \\ c_9 \\ c_{11} \end{matrix} & \begin{bmatrix} 0 & 0 & 0 & 1 & 0 & 0 \\ 0 & 0 & 1 & 0 & 0 & 1 \\ 0 & 0 & 0 & 1 & 0 & 1 \\ 0 & 0 & 1 & 0 & 0 & 0 \\ 0 & 0 & 0 & 1 & 0 & 1 \\ 0 & 0 & 0 & 1 & 0 & 0 \end{bmatrix} \end{matrix} .$$

Thus using M_E , M_F and M_G we can study the problem using each of the two experts opinion.

Now we can find also 3 experts opinion only in two ways. Taking the experts E_1, E_2 and E_3 or E_2, E_3 and E_4 .

To find the opinion of the experts E_1, E_2 and E_3 we should get the merged graph of the three directed graph A, B and C. Let H denote the merged graph of the graphs A, B and C.

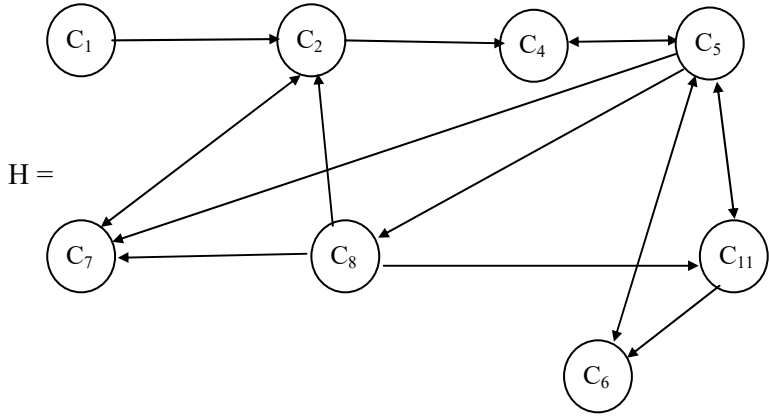

Let M_H denote the connection matrix of the merged graph M_H which is as follows.

$$M_H = \begin{matrix} & \begin{matrix} c_1 & c_2 & c_4 & c_5 & c_6 & c_7 & c_8 & c_{11} \end{matrix} \\ \begin{matrix} c_1 \\ c_2 \\ c_4 \\ c_5 \\ c_6 \\ c_7 \\ c_8 \\ c_{11} \end{matrix} & \begin{bmatrix} 0 & 1 & 0 & 0 & 0 & 0 & 0 & 0 \\ 0 & 0 & 1 & 0 & 0 & 1 & 1 & 0 \\ 0 & 0 & 0 & 1 & 0 & 0 & 0 & 0 \\ 0 & 0 & 1 & 0 & 1 & 1 & 1 & 1 \\ 0 & 0 & 0 & 1 & 0 & 0 & 0 & 0 \\ 0 & 1 & 0 & 0 & 0 & 0 & 0 & 0 \\ 0 & 1 & 0 & 0 & 0 & 1 & 0 & 1 \\ 0 & 0 & 0 & 1 & 1 & 0 & 0 & 0 \end{bmatrix} \end{matrix} .$$

Using M_H we can get the resultant of all attributes except C_3, C_9 and C_{10} .

Now we find the merged graph I of the three directed graphs B, C and D of the experts E_2, E_3 and E_4 .

The merged graph I of the directed graphs B, C and D are as follows.

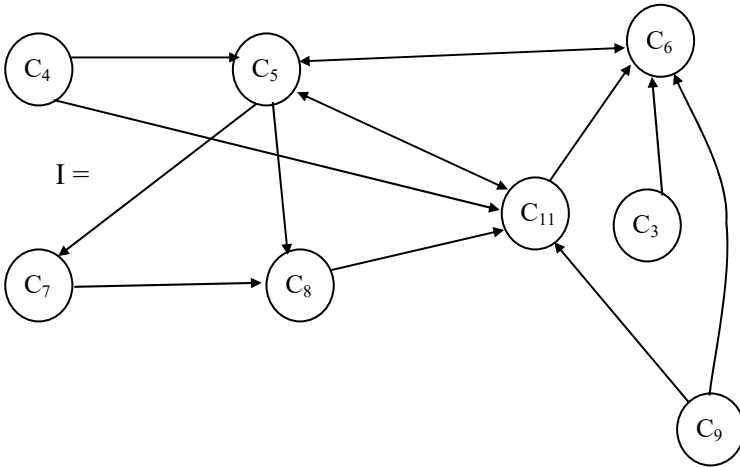

The connection matrix M_I of the merged graph I as follows.

$$M_I = \begin{matrix} & c_3 & c_4 & c_5 & c_6 & c_7 & c_8 & c_9 & c_{11} \\ \begin{matrix} c_3 \\ c_4 \\ c_5 \\ c_6 \\ c_7 \\ c_8 \\ c_9 \\ c_{11} \end{matrix} & \begin{bmatrix} 0 & 0 & 0 & 1 & 0 & 0 & 0 & 0 \\ 0 & 0 & 1 & 0 & 0 & 0 & 0 & 1 \\ 0 & 0 & 0 & 1 & 1 & 1 & 0 & 1 \\ 0 & 0 & 1 & 0 & 0 & 0 & 0 & 0 \\ 0 & 0 & 0 & 0 & 0 & 1 & 0 & 0 \\ 0 & 0 & 0 & 0 & 0 & 0 & 0 & 1 \\ 0 & 0 & 0 & 1 & 0 & 0 & 0 & 1 \\ 0 & 0 & 1 & 1 & 0 & 0 & 0 & 0 \end{bmatrix} & . \end{matrix}$$

Using the connection matrix M_I we can study the effect of the 8 attributes.

We cannot find the effect of C_1 , C_2 and C_{10} .

Finally we get the merged directed graph I of the four graphs A, B, C and D which is as follows.

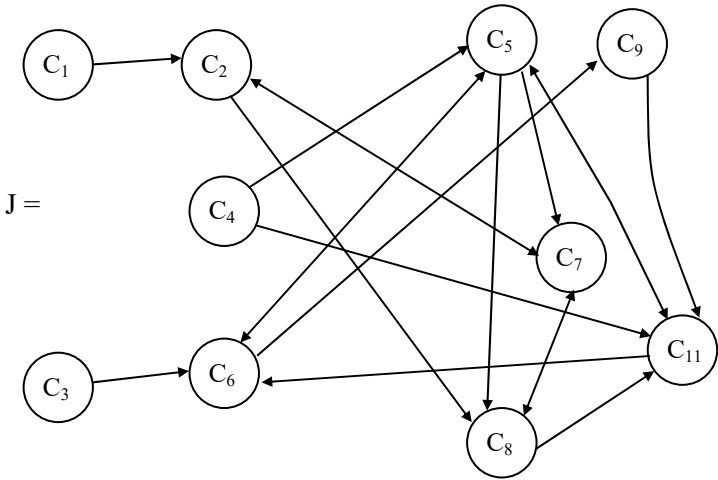

Now we find the connection merged matrix of the merged directed graph J which is denoted by M_J .

$$M_J = \begin{matrix} & c_1 & c_2 & c_3 & c_4 & c_5 & c_6 & c_7 & c_8 & c_9 & c_{11} \\ \begin{matrix} c_1 \\ c_2 \\ c_3 \\ c_4 \\ c_5 \\ c_6 \\ c_7 \\ c_8 \\ c_9 \\ c_{11} \end{matrix} & \begin{bmatrix} 0 & 1 & 0 & 0 & 0 & 0 & 0 & 0 & 0 & 0 & 0 \\ 0 & 0 & 0 & 0 & 0 & 0 & 1 & 1 & 0 & 0 & 0 \\ 0 & 0 & 0 & 0 & 0 & 1 & 0 & 0 & 0 & 0 & 0 \\ 0 & 0 & 0 & 0 & 1 & 0 & 0 & 0 & 0 & 0 & 1 \\ 0 & 0 & 0 & 0 & 0 & 1 & 1 & 1 & 0 & 0 & 0 \\ 0 & 0 & 0 & 0 & 1 & 0 & 0 & 0 & 0 & 0 & 0 \\ 0 & 0 & 0 & 0 & 0 & 0 & 0 & 1 & 0 & 0 & 0 \\ 0 & 0 & 0 & 0 & 0 & 0 & 1 & 0 & 0 & 0 & 1 \\ 0 & 0 & 0 & 0 & 0 & 0 & 0 & 0 & 0 & 1 & 0 \\ 0 & 0 & 0 & 0 & 1 & 1 & 0 & 0 & 0 & 0 & 0 \end{bmatrix} \end{matrix} .$$

Thus we see all the four experts opinion is merged and we get the merged connection matrix M_J .

Now we proceed onto describe the model abstractly.

Let c_1, c_2, \dots, c_n be n attributes with which t experts say E_1, E_2, \dots, E_t work on some problem using FCMs. However these experts choose only a subset from the set of concepts c_1, c_2, \dots, c_n .

Without loss of generality let us assume the expert E_1 and E_2 have common attributes and the expert E_1 does not share any common attribute with any of the other experts E_3, E_4, \dots, E_t . Consider the expert E_2 , E_2 has common attributes with E_1 and E_3 and none others E_4, E_5, \dots, E_t . Likewise expert E_3 has common attributes only with E_4 and E_2 and none others. Similarly expert E_4 has common attributes only with E_5 and E_3 and none others and so on. Thus the expert E_i has common attributes with the expert E_{i-1} and E_{i+1} for $i = 1, 2, \dots, t - 1$. We see the expert E_t has only common attributes with E_{t-1} only we see thus $E_1 \cap E_2 \neq \phi$. $E_1 \cap E_i = \phi$ for all $3 \leq i \leq t$. That is $E_i \cap E_{i+1} \neq \phi$ for $i = 1, 2, \dots, t - 1$.

When experts distribute the nodes and concepts in this way among themselves we can work with the merged FCMs which we call as specially linked merged FCMs.

Study of this concept is described and developed in an example. Now using this specially linked merged FCMs we can study the problem.

Now we introduce yet another new type of merged FCMs which is little different from the other two merged FCMs models. Let us suppose we have say $C = \{C_1, C_2, \dots, C_n\}$ to be n -attributes associated a problem. Suppose E_1, E_2, \dots, E_t be t experts who works with some attributes from the subset of C . Suppose r of the experts from the t experts $r < t$ happen to contribute to the merged FCMs in such a way that these r experts say E_1, \dots, E_r cover C with $E_i \cap E_j \neq \phi$ for $1 \leq i, j \leq r$ (or they cover C with $E_i \cap E_{i+1} \neq \phi$, $1 \leq i \leq r-1$) then we get the merged FCMs model to study the problem.

Further we can choose some other s experts from the t experts ($s < t$) to cover C such that some from these s -experts are also in the r -experts mentioned earlier. Thus we can have say m such groups and these m -group of experts have non empty intersection. While studying these merged FCMs we clearly see some experts are vital that is they appear in many of the groups, so that unintentionally these experts play a major role in every merged FCMs.

Some experts may appear only in one group of experts and some experts may appear in two groups and so on.

If an experts finds place in every m -group we call that expert to be a strongly influencing vital expert. It may so happen we can have more than one expert to be a strongly influencing vital expert. The expert who finds in one and only group will be known as the non vital or non influencing expert. No expert need to feel their expertise is lost for grouping is not going to bias as no role is played by the humans.

We will illustrate this model by an example.

The example is only artificial as this example is not based on any real world problem. Further adopting this to any real world problem is at a risk of bias as this example is only a mere illustration and nothing more.

However the techniques of this model are vital and this model is described for experts / researchers to understand the situation.

Example 2.9: Let $C = \{c_1, c_2, \dots, c_{13}\}$ be the 13 concepts related with the problem. Suppose 5 experts work with some attributes from the 13 attributes set C .

Let E_1, E_2, E_3, E_4 and E_5 be the five experts who work on the problem.

Let the expert E_1 work with the nodes $\{c_1, c_2, c_3, c_{10}, c_4\}$. The expert E_2 works with the following nodes $\{c_3, c_4, c_1, c_6, c_9\}$. The third expert E_3 works with the nodes $\{c_8, c_5, c_7, c_{12}, c_{13}\}$, expert E_4 works with the nodes $\{c_1, c_3, c_5, c_{10}, c_{11}\}$ and the expert E_5 works with attributes $\{c_2, c_5, c_{10}, c_{12}\}$.

We give the directed graph associated with each of the five experts in the following.

The directed graph I given by the first expert E_1 is as follows.

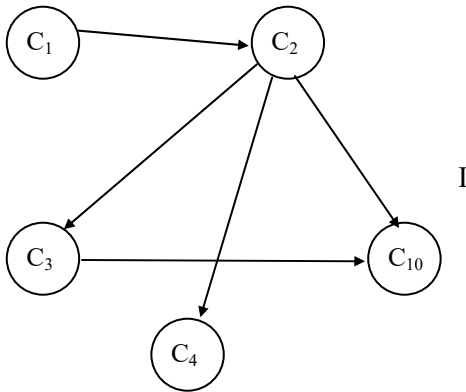

The directed graph II given by the second expert E_2 is as follows.

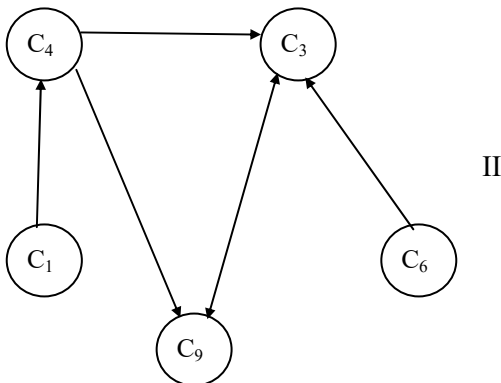

The directed graph III of the third expert is given by the following.

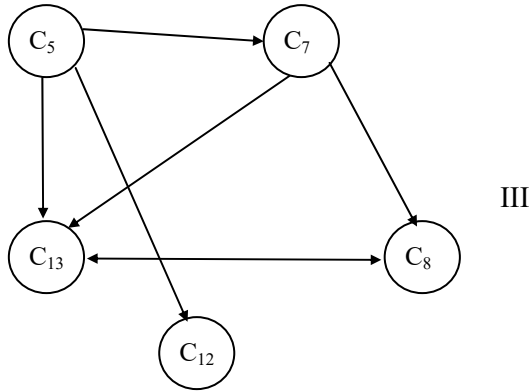

The directed graph IV of the expert four E_4 is given in the following.

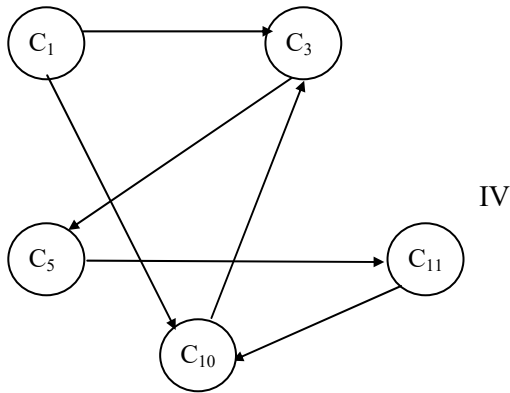

The directed graph V given by the fifth expert is as follows.

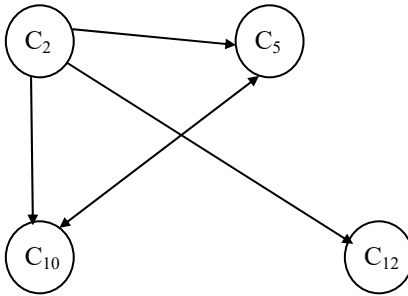

V

We get the following connection matrices for these directed graphs I, II, III, IV and V respectively. They are denoted by M_I , M_{II} , M_{III} , M_{IV} and M_V respectively.

The connection matrix M_I of the directed graph I given by the expert I is as follows.

$$M_I = \begin{matrix} & c_1 & c_2 & c_3 & c_4 & c_{10} \\ \begin{matrix} c_1 \\ c_2 \\ c_3 \\ c_4 \\ c_{10} \end{matrix} & \begin{bmatrix} 0 & 1 & 0 & 0 & 0 \\ 0 & 0 & 1 & 1 & 1 \\ 0 & 0 & 0 & 0 & 1 \\ 0 & 0 & 0 & 0 & 0 \\ 0 & 0 & 0 & 0 & 0 \end{bmatrix} \end{matrix}$$

The connection matrix M_{II} of the directed graph II is as follows:

$$M_{II} = \begin{matrix} & c_1 & c_3 & c_4 & c_6 & c_9 \\ \begin{matrix} c_1 \\ c_3 \\ c_4 \\ c_6 \\ c_9 \end{matrix} & \begin{bmatrix} 0 & 0 & 1 & 0 & 0 \\ 0 & 0 & 0 & 0 & 1 \\ 0 & 1 & 0 & 0 & 1 \\ 0 & 1 & 0 & 0 & 0 \\ 0 & 1 & 0 & 0 & 0 \end{bmatrix} \end{matrix}.$$

The connection matrix M_{III} of the directed graph III is as follows.

$$M_{III} = \begin{matrix} & c_5 & c_7 & c_8 & c_{12} & c_{13} \\ \begin{matrix} c_5 \\ c_7 \\ c_8 \\ c_{12} \\ c_{13} \end{matrix} & \begin{bmatrix} 0 & 1 & 0 & 1 & 1 \\ 0 & 0 & 1 & 0 & 1 \\ 0 & 0 & 0 & 0 & 1 \\ 0 & 0 & 0 & 0 & 0 \\ 0 & 0 & 1 & 0 & 0 \end{bmatrix} \end{matrix} .$$

Let M_{IV} denote the connection matrix of the directed graph IV of expert four which is as follows.

$$M_{IV} = \begin{matrix} & c_1 & c_3 & c_5 & c_{10} & c_{11} \\ \begin{matrix} c_1 \\ c_3 \\ c_5 \\ c_{10} \\ c_{11} \end{matrix} & \begin{bmatrix} 0 & 1 & 0 & 1 & 0 \\ 0 & 0 & 1 & 0 & 0 \\ 0 & 0 & 0 & 0 & 1 \\ 0 & 1 & 0 & 0 & 0 \\ 0 & 0 & 0 & 1 & 0 \end{bmatrix} \end{matrix} .$$

Let M_V denote the connection matrix of the directed graph V of the expert which is as follows:

$$M_V = \begin{matrix} & c_2 & c_5 & c_{10} & c_{12} \\ \begin{matrix} c_2 \\ c_5 \\ c_{10} \\ c_{12} \end{matrix} & \begin{bmatrix} 0 & 1 & 1 & 1 \\ 0 & 0 & 1 & 0 \\ 0 & 1 & 0 & 0 \\ 0 & 0 & 0 & 0 \end{bmatrix} \end{matrix} .$$

Now see by merging the experts E_2, E_4, E_3 and E_5 or experts E_1, E_2, E_3 and E_4 we get covered all the 13 attributes or nodes.

However to get all the nodes we need the three experts set E_2, E_3 and E_4 . For the expert E_2 alone has used the nodes C_6 and C_9 and no other expert has used them. Expert E_3 cannot be overlooked for the expert E_3 alone has worked with the nodes C_8 and C_{13} . Expert E_4 cannot be over looked for he alone has used the node C_{11} . Thus working with the merged or integrated FCMs the three experts are very essential we can choose expert E_1 or expert E_2 as per the wishes of the experts or the researcher who works in the problem.

We merge the four experts E_1, E_2, E_3 and E_4 by merging the directed graphs given by them which is as follows.

Let A denote the merged directed graph of the four experts E_1, E_2, E_3 and E_4 .

The merged directed graph A of the directed graphs E_1, E_2, E_3 and E_4 and the merged connection matrix of A be denoted by M_A , which is as follows.

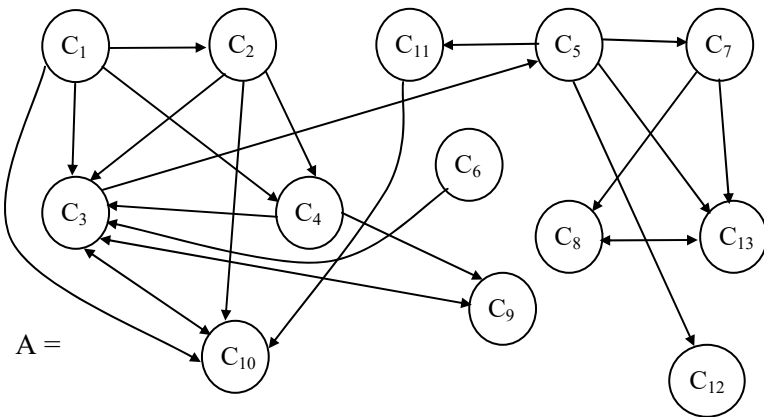

$$M_A = \begin{matrix} & c_1 & c_2 & c_3 & c_4 & c_5 & c_6 & c_7 & c_8 & c_9 & c_{10} & c_{11} & c_{12} & c_{13} \\ \begin{matrix} c_1 \\ c_2 \\ c_3 \\ c_4 \\ c_5 \\ c_6 \\ c_7 \\ c_8 \\ c_9 \\ c_{10} \\ c_{11} \\ c_{12} \\ c_{13} \end{matrix} & \begin{bmatrix} 0 & 1 & 1 & 1 & 0 & 0 & 0 & 0 & 0 & 1 & 0 & 0 & 0 \\ 0 & 0 & 1 & 1 & 0 & 0 & 0 & 0 & 0 & 1 & 0 & 0 & 0 \\ 0 & 0 & 0 & 0 & 1 & 0 & 0 & 0 & 1 & 1 & 0 & 0 & 0 \\ 0 & 0 & 1 & 0 & 0 & 0 & 0 & 0 & 1 & 0 & 0 & 0 & 0 \\ 0 & 0 & 0 & 0 & 0 & 0 & 1 & 0 & 0 & 0 & 1 & 1 & 1 \\ 0 & 0 & 1 & 0 & 0 & 0 & 0 & 0 & 0 & 0 & 0 & 0 & 0 \\ 0 & 0 & 0 & 0 & 0 & 0 & 0 & 1 & 0 & 0 & 0 & 0 & 1 \\ 0 & 0 & 0 & 0 & 0 & 0 & 0 & 0 & 0 & 0 & 0 & 0 & 1 \\ 0 & 0 & 1 & 0 & 0 & 0 & 0 & 0 & 0 & 0 & 0 & 0 & 0 \\ 0 & 0 & 1 & 0 & 0 & 0 & 0 & 0 & 0 & 0 & 0 & 0 & 0 \\ 0 & 0 & 0 & 0 & 0 & 0 & 0 & 0 & 0 & 1 & 0 & 0 & 0 \\ 0 & 0 & 0 & 0 & 0 & 0 & 0 & 0 & 0 & 0 & 0 & 0 & 0 \\ 0 & 0 & 0 & 0 & 0 & 0 & 0 & 1 & 0 & 0 & 0 & 0 & 0 \end{bmatrix} \end{matrix} .$$

Suppose we merge the opinion of the experts E_2, E_3, E_4 and E_5 by merging the directed graph II, III, IV and V. Let B denote the merged directed graph which is as follows.

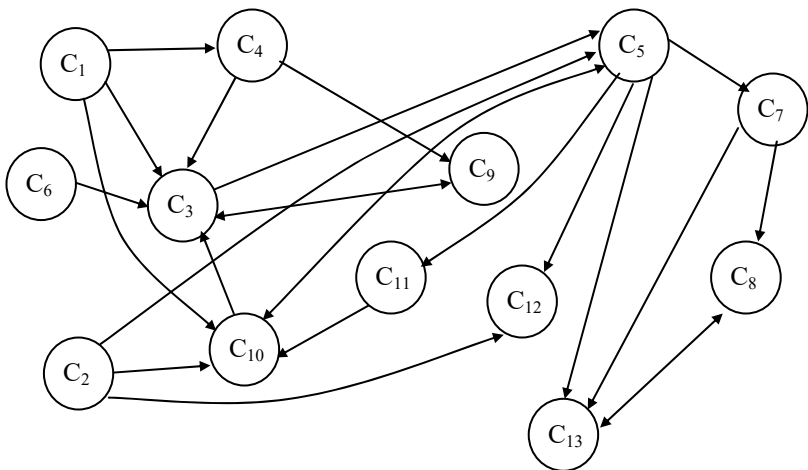

Using the merged directed graph B we obtained the merged connection matrix of B which will serve as the dynamical system of the merged FCMs. Let M_B denote the connection matrix of B.

$$M_B = \begin{matrix} & c_1 & c_2 & c_3 & c_4 & c_5 & c_6 & c_7 & c_8 & c_9 & c_{10} & c_{11} & c_{12} & c_{13} \\ \begin{matrix} c_1 \\ c_2 \\ c_3 \\ c_4 \\ c_5 \\ c_6 \\ c_7 \\ c_8 \\ c_9 \\ c_{10} \\ c_{11} \\ c_{12} \\ c_{13} \end{matrix} & \begin{bmatrix} 0 & 0 & 1 & 1 & 0 & 0 & 0 & 0 & 0 & 0 & 1 & 0 & 0 & 0 \\ 0 & 0 & 0 & 0 & 1 & 0 & 0 & 0 & 0 & 0 & 1 & 0 & 1 & 0 \\ 0 & 0 & 0 & 0 & 1 & 0 & 0 & 0 & 0 & 1 & 0 & 0 & 0 & 0 \\ 0 & 0 & 1 & 0 & 0 & 0 & 0 & 0 & 0 & 1 & 0 & 0 & 0 & 0 \\ 0 & 0 & 0 & 0 & 0 & 0 & 1 & 0 & 0 & 0 & 1 & 1 & 1 & 1 \\ 0 & 0 & 1 & 0 & 0 & 0 & 0 & 0 & 0 & 0 & 0 & 0 & 0 & 0 \\ 0 & 0 & 0 & 0 & 0 & 0 & 0 & 1 & 0 & 0 & 0 & 0 & 0 & 1 \\ 0 & 0 & 0 & 0 & 0 & 0 & 0 & 0 & 0 & 0 & 0 & 0 & 0 & 1 \\ 0 & 0 & 1 & 0 & 0 & 0 & 0 & 0 & 0 & 0 & 0 & 0 & 0 & 0 \\ 0 & 0 & 1 & 0 & 1 & 0 & 0 & 0 & 0 & 0 & 0 & 0 & 0 & 0 \\ 0 & 0 & 0 & 0 & 0 & 0 & 0 & 0 & 0 & 0 & 1 & 0 & 0 & 0 \\ 0 & 0 & 0 & 0 & 0 & 0 & 0 & 0 & 0 & 0 & 0 & 0 & 0 & 0 \\ 0 & 0 & 0 & 0 & 0 & 0 & 0 & 1 & 0 & 0 & 0 & 0 & 0 & 0 \end{bmatrix} \end{matrix} .$$

We see both the connection matrices are different and they give different resultants.

We see E_1 and E_5 are experts who are not that strong only partly strong one of them is sufficient to give a merged or integrated FCMs model.

However both models can be used as they are different. In the further following chapter a new average technique will be used and also in another chapter the concept of Kosko-Hamming distance will be introduced and that can applied to the resultants given by the two models for the same initial state vector. We have throughout used only FCMs whose related matrices take values from the set $\{0, 1\}$.

Now when we have a subset from the set of experts set $E = \{E_1, E_2, \dots, E_t\}$ which can give the merged FCMs taking all the n concepts we take all such subsets of E and find the merged FCMs.

Using new average simple FCMs which will be defined in chapter four of this book we find a new single of integrated model which can predict the solutions of the problem.

Further we proceed onto describe the notion of merged NCMs.

The basic notion of NCMs and the concept of neutrosophic graphs have been introduced in chapter I.

We now give a few types of merged neutrosophic NCMs and mixed merged NCMs and FCMs. In case of NCMs we have two types of merging and both merging pave way to only NCMs.

We will define, develop and describe these situations by some examples.

We know a neutrosophic directed graph associated with NCMs.

We just show how merging takes place among neutrosophic graphs.

Suppose we have two neutrosophic graphs G_1 and G_2 which has some common vertices.

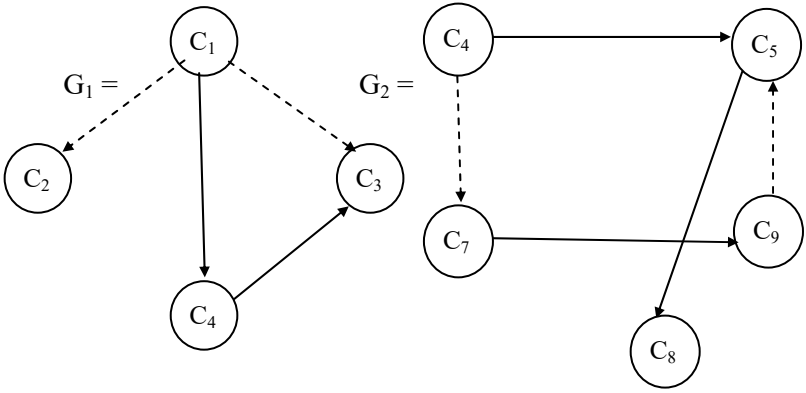

We see both the graphs have only C_4 to be the common vertex so merging can be done without any difficulty for only one common vertex is C_4 .

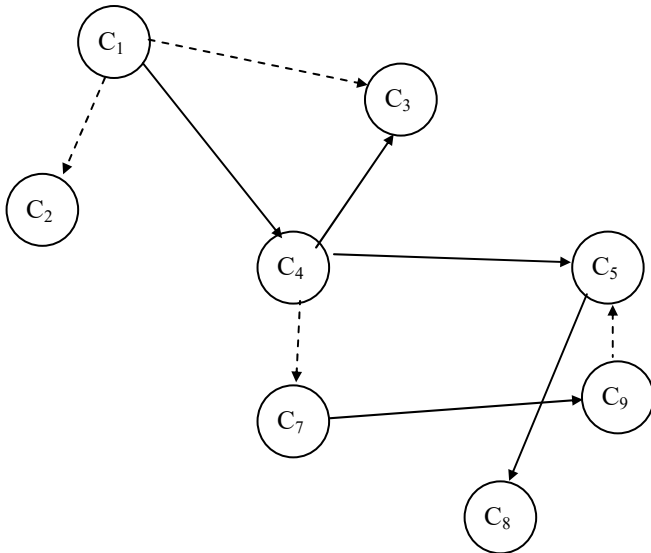

Further we assume in NCMs in general the vertices are not neutrosophic only the edges are neutrosophic. Further merging of an neutrosophic edge with the real edge cannot be accepted how to overcome or redefine the edge.

We redefine the edge in a very flexible way.

If the expert feels neutrosophy that is indeterminacy over usual edge let them opt for indeterminacy if they feel contrary let them take the real.

But however if one chooses to take indeterminacy till the end of the problem that is while forming each and every merged graph the same should be adopted. Only under these conditions we can get NCMs merged model.

We will first illustrate this situation by some examples.

Example 2.10: Let G_1 and G_2 be any two neutrosophic graphs which has some neutrosophic edges and vertices in common

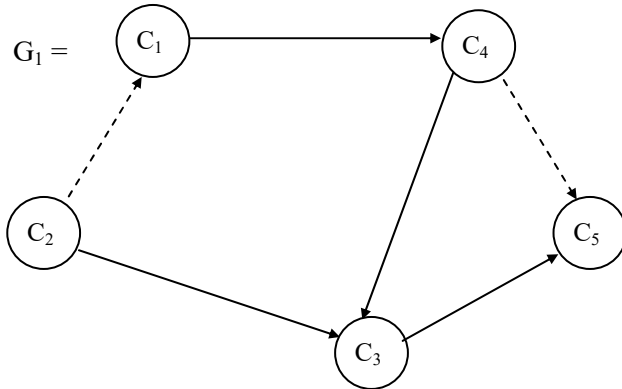

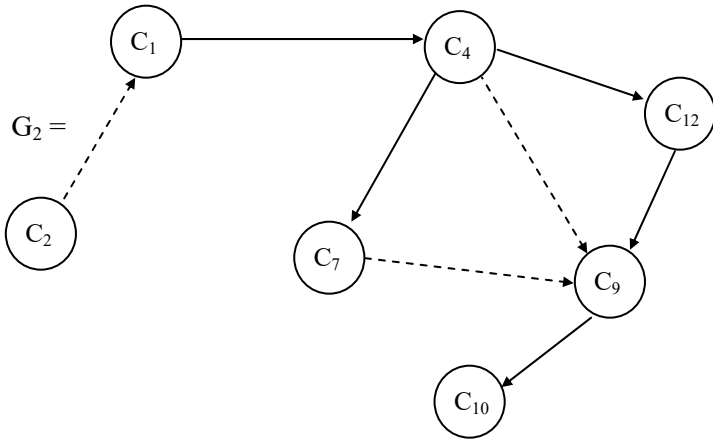

be the two neutrosophic graphs.

We can merge the two graphs in one and only one way.

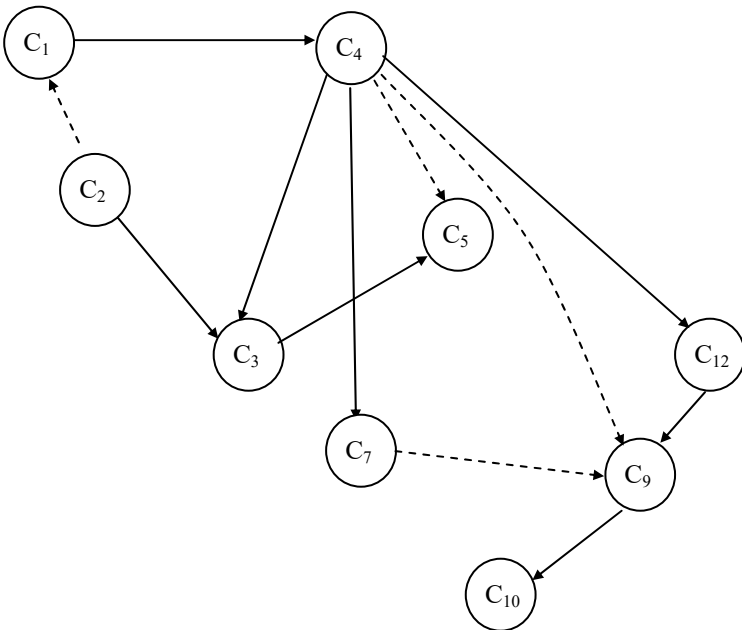

The merging is carried out in a direct way as there is no conflicts about the edges.

This is the way merging is carried out without any difficulty.

Next we find merging of the two neutrosophic graphs G_1 and G_2 .

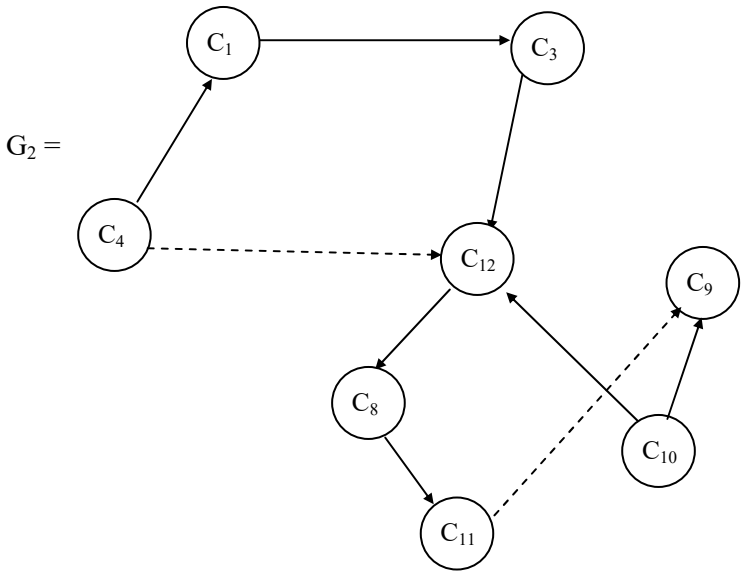
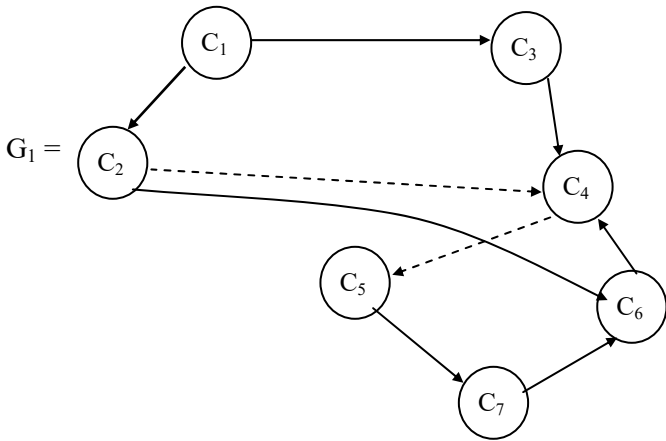

The merged graph of G_1 with G_2 is as follows.

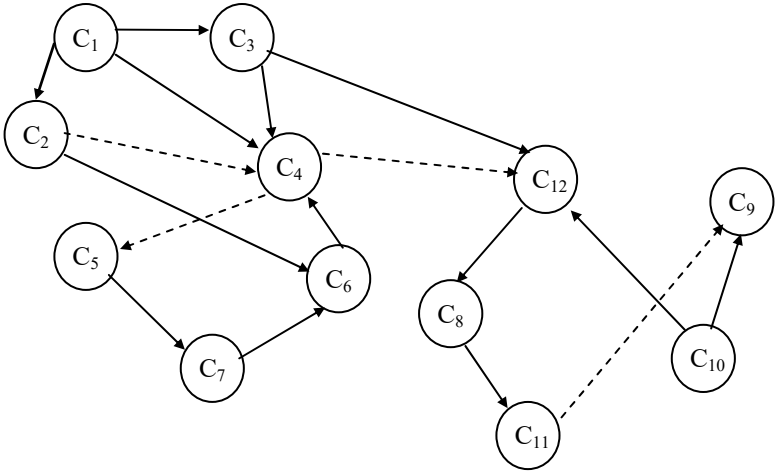

This is the way neutrosophic graphs are merged. We see the merging is done not under any assumption.

Suppose we have two neutrosophic graphs G_1 and G_2 which is as follows.

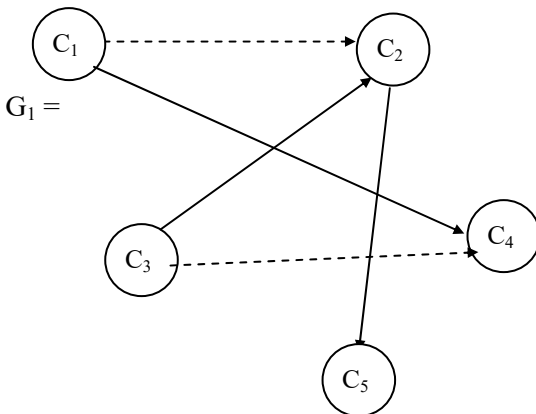

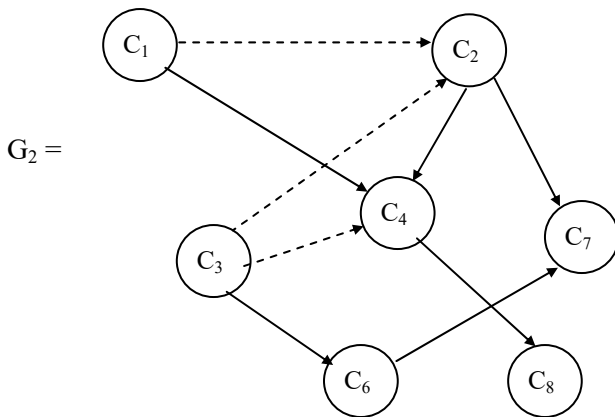

We can merge the graph G_1 and G_2 which is as follows.

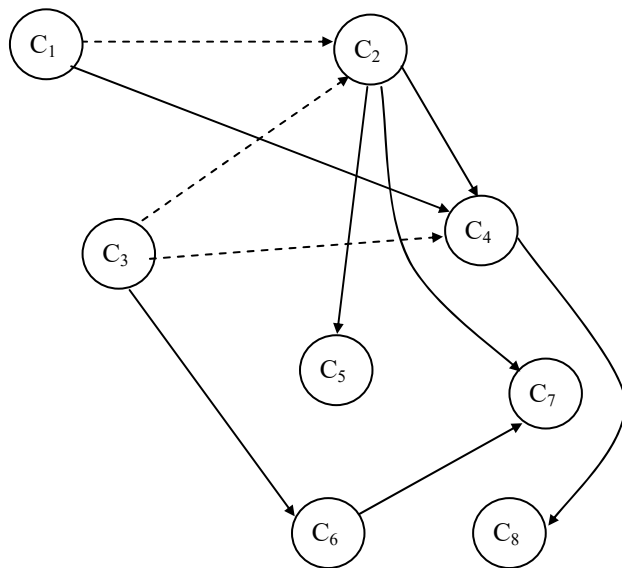

We see by merging the neutrosophic edge and real edge we get the neutrosophic edge and so on. Here the experts opts to take C_3 to C_2 as a neutrosophic edge only.

This is not the usual merging.

Now using these techniques we work for the merging NCMs.

Suppose we wish to merge two NCMs whose directed graphs G_1 and G_2 are as follows:

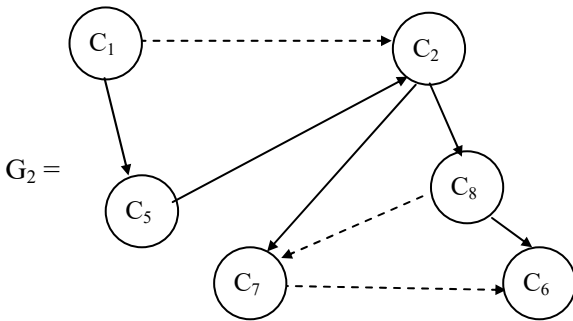
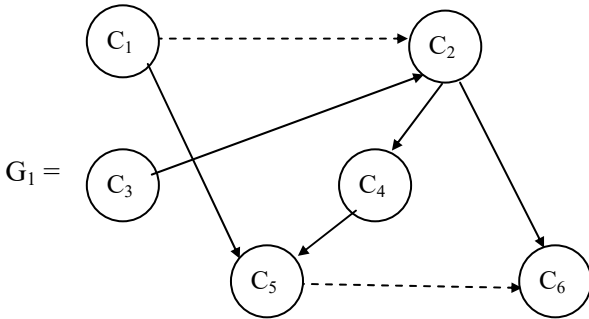

The merged graph of G_1 and G_2 is as follows.

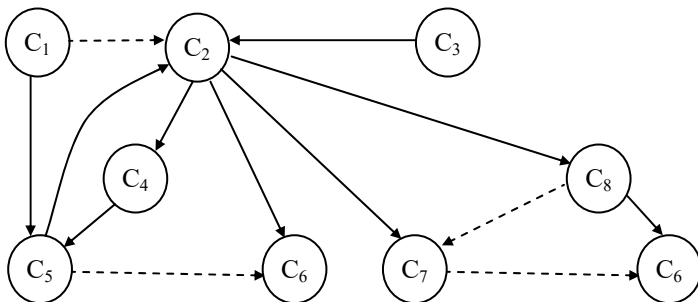

G is the merged neutrosophic graph of G_1 and G_2 .

As in case of merged FCMs we can get merged NCMs of the three types apart from those mixed merged NCMs and FCMs.

Let $\{C_1, C_2, \dots, C_n\}$ be n attributes or nodes. Suppose t experts E_1, E_2, \dots, E_t work on the problem working will some attributes from the set C .

Suppose all of them work with only Neutrosophic Cognitive Maps (NCMs) model we can find the merged NCMs as in case of FCMs.

Let us suppose c_1, c_2, \dots, c_{10} are the 10 nodes or attributes related with the some problem. Suppose only three experts E_1, E_2 and E_3 work with the problem.

Let the expert E_1 work with the nodes $\{C_1, C_3, C_5, C_7$ and $C_9\}$. Let the expert E_2 work with the nodes $\{C_1, C_2, C_4, C_7, C_6, C_8\}$ and the expert E_3 works with the nodes $\{C_2, C_3, C_{10}, C_7, C_8, C_9\}$. We can find the merged graph of the NCMs using the neutrosophic graphs G_1, G_2 and G_3 of the experts E_1, E_2 and E_3 respectively.

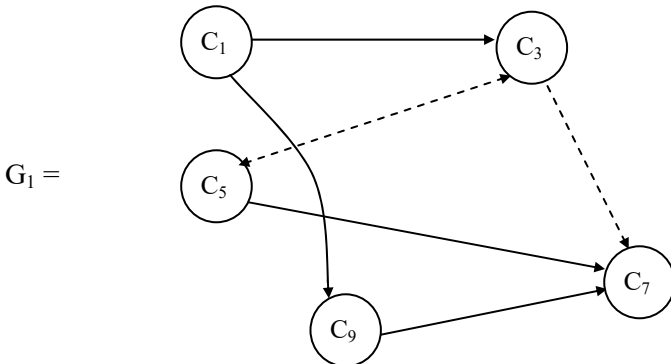

The neutrosophic connection matrix M_{G_1} of the graph G_1 is as follows.

$$M_{G_1} = \begin{matrix} & c_1 & c_3 & c_5 & c_7 & c_9 \\ \begin{matrix} c_1 \\ c_3 \\ c_5 \\ c_7 \\ c_9 \end{matrix} & \begin{bmatrix} 0 & 1 & 0 & 0 & 1 \\ 0 & 0 & 1 & 1 & 0 \\ 0 & 1 & 0 & 1 & 0 \\ 0 & 0 & 0 & 0 & 0 \\ 0 & 0 & 0 & 1 & 0 \end{bmatrix} \end{matrix}.$$

The neutrosophic directed graph G_2 given by the expert E_2 is as follows:

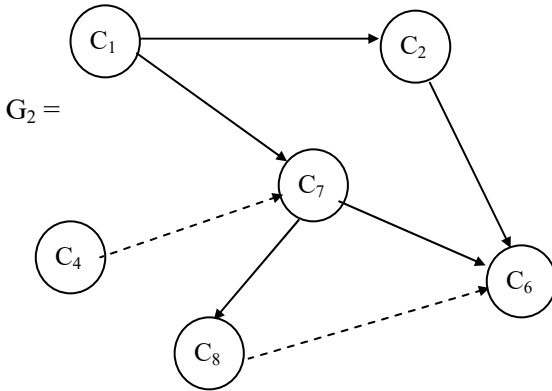

The connection matrix M_{G_2} is given by G_2 is as follows.

$$M_{G_2} = \begin{matrix} & c_1 & c_2 & c_4 & c_6 & c_7 & c_8 \\ \begin{matrix} c_1 \\ c_2 \\ c_4 \\ c_6 \\ c_7 \\ c_8 \end{matrix} & \begin{bmatrix} 0 & 1 & 0 & 0 & 1 & 0 \\ 0 & 0 & 0 & 1 & 0 & 0 \\ 0 & 0 & 0 & 0 & 1 & 0 \\ 0 & 0 & 0 & 0 & 0 & 0 \\ 0 & 0 & 0 & 1 & 0 & 1 \\ 0 & 0 & 0 & 1 & 0 & 0 \end{bmatrix} \end{matrix}.$$

The directed neutrosophic graph G_3 given by expert 3 is as follows.

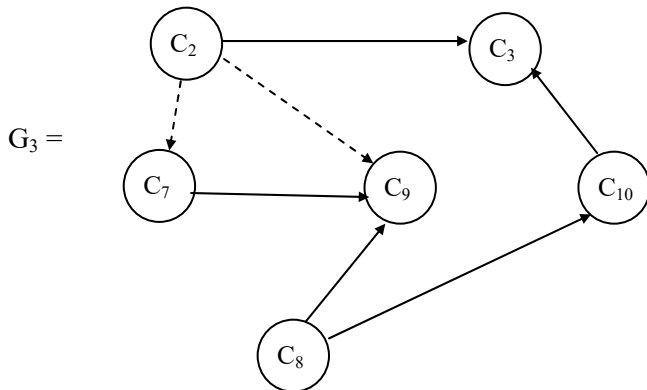

The neutrosophic connection matrix associated with G_3 is as follows:

$$M_{G_3} = \begin{matrix} & c_2 & c_3 & c_7 & c_8 & c_9 & c_{10} \\ \begin{matrix} c_2 \\ c_3 \\ c_7 \\ c_8 \\ c_9 \\ c_{10} \end{matrix} & \begin{bmatrix} 0 & 1 & I & 0 & I & 0 \\ 0 & 0 & 0 & 0 & 0 & 0 \\ 0 & 0 & 0 & 0 & 1 & 0 \\ 0 & 0 & 0 & 0 & 1 & 1 \\ 0 & 0 & 0 & 0 & 0 & 0 \\ 0 & 1 & 0 & 0 & 0 & 0 \end{bmatrix} \end{matrix} .$$

Now we can merge the graphs G_1 and G_2 .

Let H be the merged graph of G_1 and G_2 which is as follows:

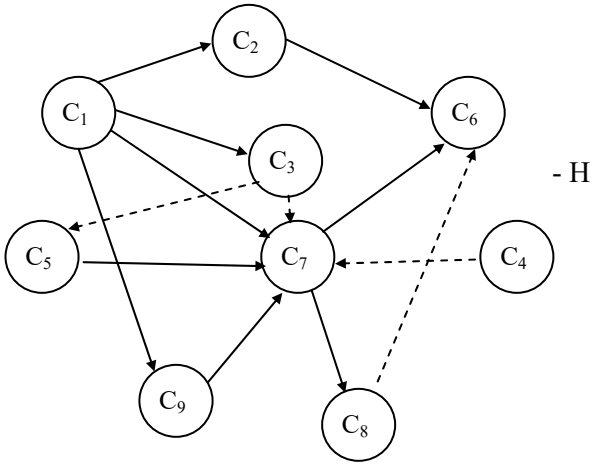

The neutrosophic merged connection matrix M_H of H is as follows:

$$M_H = \begin{matrix} & \begin{matrix} c_1 & c_2 & c_3 & c_4 & c_5 & c_6 & c_7 & c_8 & c_9 \end{matrix} \\ \begin{matrix} c_1 \\ c_2 \\ c_3 \\ c_4 \\ c_5 \\ c_6 \\ c_7 \\ c_8 \\ c_9 \end{matrix} & \begin{bmatrix} 0 & 1 & 1 & 0 & 0 & 0 & 1 & 0 & 1 \\ 0 & 0 & 0 & 0 & 0 & 1 & 0 & 0 & 0 \\ 0 & 0 & 0 & 0 & I & 0 & I & 0 & 0 \\ 0 & 0 & 0 & 0 & 0 & 0 & I & 0 & 0 \\ 0 & 0 & 0 & 0 & 0 & 0 & 1 & 0 & 0 \\ 0 & 0 & 0 & 0 & 0 & 0 & 0 & 0 & 0 \\ 0 & 0 & 0 & 0 & 0 & 1 & 0 & 1 & 0 \\ 0 & 0 & 0 & 0 & 0 & 0 & 0 & 0 & 0 \\ 0 & 0 & 0 & 0 & 0 & 0 & 1 & 0 & 0 \end{bmatrix} \end{matrix}.$$

We can also merge the neutrosophic graph G_1 with G_3 .

Let I denote the merged neutrosophic graph which is as follows.

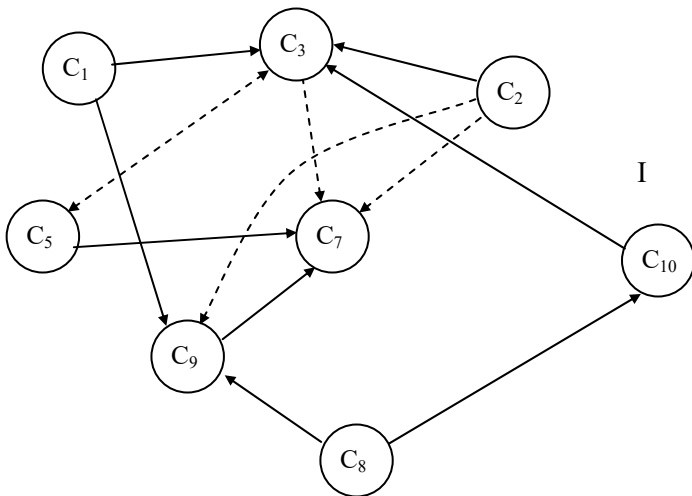

Let M_I denote the neutrosophic merged connection matrix of the neutrosophic graph I .

$$M_I = \begin{matrix} & c_1 & c_2 & c_3 & c_5 & c_7 & c_8 & c_9 & c_{10} \\ \begin{matrix} c_1 \\ c_2 \\ c_3 \\ c_5 \\ c_7 \\ c_8 \\ c_9 \\ c_{10} \end{matrix} & \begin{bmatrix} 0 & 0 & 1 & 0 & 0 & 0 & 1 & 0 \\ 0 & 0 & 1 & 0 & I & 0 & I & 0 \\ 0 & 0 & 0 & I & I & 0 & 0 & 0 \\ 0 & 0 & I & 0 & 1 & 0 & 0 & 0 \\ 0 & 0 & 0 & 0 & 0 & 0 & 1 & 0 \\ 0 & 0 & 0 & 0 & 0 & 0 & 1 & 1 \\ 0 & 0 & 0 & 0 & 1 & 0 & 0 & 0 \\ 0 & 0 & 1 & 0 & 0 & 0 & 0 & 0 \end{bmatrix} \end{matrix}$$

Now we get the merged graph J of the graphs G_2 with G_3 which is as follows.

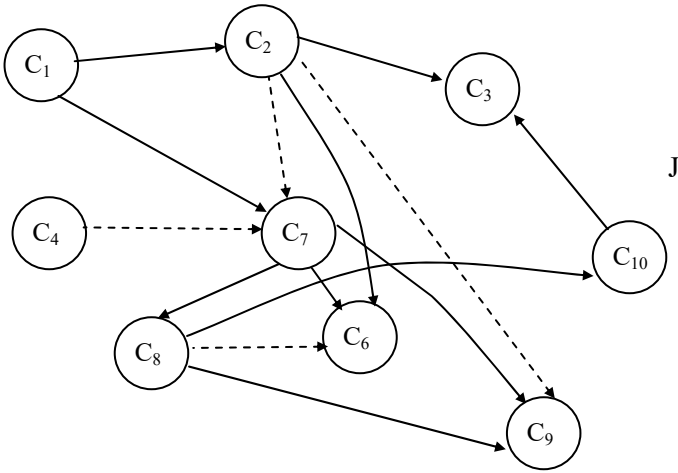

$$M_J = \begin{matrix} & c_1 & c_2 & c_3 & c_4 & c_6 & c_7 & c_8 & c_9 & c_{10} \\ \begin{matrix} c_1 \\ c_2 \\ c_3 \\ c_4 \\ c_6 \\ c_7 \\ c_8 \\ c_9 \\ c_{10} \end{matrix} & \begin{bmatrix} 0 & 1 & 0 & 0 & 0 & 1 & 0 & 0 & 0 \\ 0 & 0 & 1 & 0 & 1 & 1 & 0 & 1 & 0 \\ 0 & 0 & 0 & 0 & 0 & 0 & 0 & 0 & 0 \\ 0 & 0 & 0 & 0 & 0 & 1 & 0 & 0 & 0 \\ 0 & 0 & 0 & 0 & 0 & 0 & 0 & 0 & 0 \\ 0 & 0 & 0 & 0 & 1 & 0 & 1 & 1 & 0 \\ 0 & 0 & 0 & 0 & 1 & 0 & 0 & 1 & 1 \\ 0 & 0 & 0 & 0 & 0 & 0 & 0 & 0 & 0 \\ 0 & 0 & 1 & 0 & 0 & 0 & 0 & 0 & 0 \end{bmatrix} \end{matrix}.$$

Now we can get the merged neutrosophic graph K of all the three experts E_1 , E_2 and E_3 which is as follows.

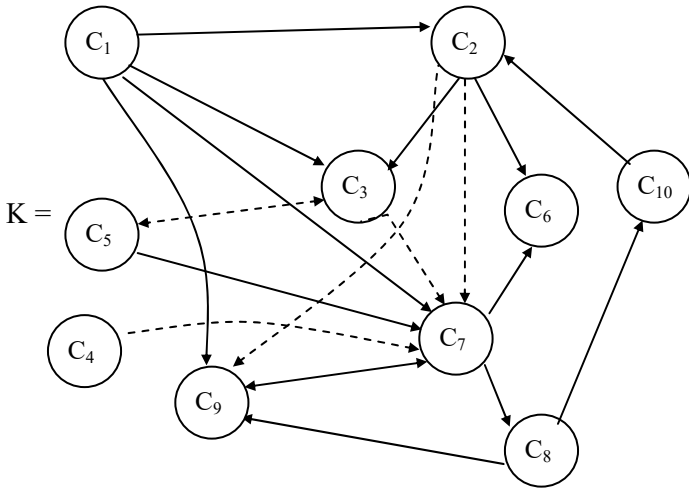

The merged connection matrix M_K of the three experts gives by the merged graph which is as follows.

$$M_K = \begin{matrix} & \begin{matrix} c_1 & c_2 & c_3 & c_4 & c_5 & c_6 & c_7 & c_8 & c_9 & c_{10} \end{matrix} \\ \begin{matrix} c_1 \\ c_2 \\ c_3 \\ c_4 \\ c_5 \\ c_6 \\ c_7 \\ c_8 \\ c_9 \\ c_{10} \end{matrix} & \begin{bmatrix} 0 & 1 & 1 & 0 & 0 & 0 & 1 & 0 & 1 & 0 \\ 0 & 0 & 1 & 0 & 0 & 1 & 1 & 0 & 1 & 0 \\ 0 & 0 & 0 & 0 & 1 & 0 & 1 & 0 & 0 & 0 \\ 0 & 0 & 0 & 0 & 0 & 0 & 1 & 0 & 0 & 0 \\ 0 & 0 & 1 & 0 & 0 & 0 & 1 & 0 & 0 & 0 \\ 0 & 0 & 0 & 0 & 0 & 0 & 0 & 0 & 0 & 0 \\ 0 & 0 & 0 & 0 & 0 & 1 & 0 & 1 & 1 & 0 \\ 0 & 0 & 0 & 0 & 0 & 1 & 0 & 0 & 1 & 1 \\ 0 & 0 & 0 & 0 & 0 & 0 & 1 & 0 & 0 & 0 \\ 0 & 1 & 0 & 0 & 0 & 0 & 0 & 0 & 0 & 0 \end{bmatrix} \end{matrix} .$$

M_K gives the total or integrated dynamical system of the merged model. Working with this given the every node of the problem.

By looking at the merged graph one will think C_7 is the vital or the most influential node. Such study about the graphs associated with the models is carried out in chapter III of this book.

Once such study is done the researcher will have more knowledge about the problem and its outcome.

Next we give the merged NCM such that the t experts say E_1, E_2, \dots, E_t work with n nodes of the problem using NCM by selecting some of the nodes from the n nodes such that the node of the expert $E_i \cap E_{i+1} \neq \phi$ for $i = 1, 2, \dots, t-1$ and $E_i \cap E_j = \phi$ if $j \neq i+1$.

Such a type of merged FCM was discussed earlier. Here we discuss the same type of problem using NCMs.

We will illustrate this situation by some examples.

Let C_1, C_2, \dots, C_{10} be the concepts associated with a problem. Let four experts work with the problem using NCMs taking some nodes from the ten nodes.

Let the expert E_1 work with the nodes $\{C_1, C_2, C_3, C_5\}$. Let the expert E_2 work with the nodes $\{C_3, C_2, C_6, C_7\}$. Let the expert E_3 work with the nodes $\{C_6, C_7, C_8, C_9\}$ and the expert E_4 works with the nodes $\{C_8, C_4, C_9, C_{10}\}$.

We see the common nodes between E_1 and E_2 is $\{C_3, C_2\}$ the common node between E_2 and E_3 is $\{C_6, C_7\}$ and the common node between E_3 and E_4 $\{C_8, C_9\}$.

However $E_i \cap E_j = \phi$ if $j = i+1; 1 \leq i \leq 4; 2 \leq j \leq 3$.

Now the directed neutrosophic graph given by the expert E_1 is as follows.

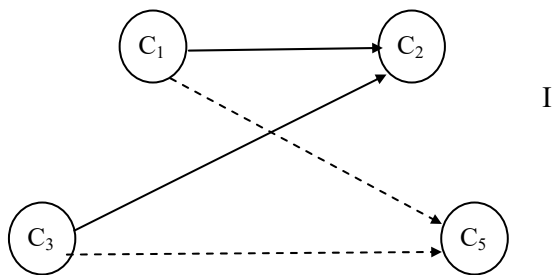

The connection neutrosophic matrix M_I associated with the directed graph I is as follows:

$$M_I = \begin{matrix} & \begin{matrix} c_1 & c_2 & c_3 & c_5 \end{matrix} \\ \begin{matrix} c_1 \\ c_2 \\ c_3 \\ c_5 \end{matrix} & \begin{bmatrix} 0 & 1 & 0 & 1 \\ 0 & 0 & 0 & 0 \\ 0 & 1 & 0 & 1 \\ 0 & 0 & 0 & 0 \end{bmatrix} \end{matrix} .$$

The directed neutrosophic graph II given by the second expert E_2 is as follows:

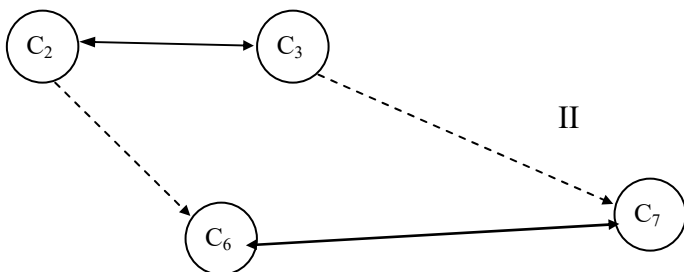

The connection neutrosophic matrix M_{II} given by the expert E_2 is as follows:

$$M_{II} = \begin{matrix} & c_2 & c_3 & c_6 & c_7 \\ \begin{matrix} c_2 \\ c_3 \\ c_6 \\ c_7 \end{matrix} & \begin{bmatrix} 0 & 1 & I & 0 \\ 1 & 0 & 0 & I \\ 0 & 0 & 0 & 1 \\ 0 & 0 & 1 & 0 \end{bmatrix} \end{matrix} .$$

The directed graph III given by the third expert E_3 is as follows:

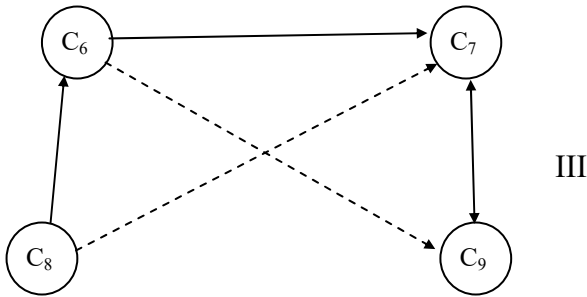

The neutrosophic connection matrix M_{III} of the graph III is as follows:

$$M_{III} = \begin{matrix} & c_6 & c_7 & c_8 & c_9 \\ \begin{matrix} c_6 \\ c_7 \\ c_8 \\ c_9 \end{matrix} & \begin{bmatrix} 0 & 1 & 0 & I \\ 0 & 0 & 0 & 1 \\ 1 & I & 0 & 0 \\ 0 & 1 & 0 & 0 \end{bmatrix} \end{matrix} .$$

The directed graph IV given by the fourth expert E_4 is as follows:

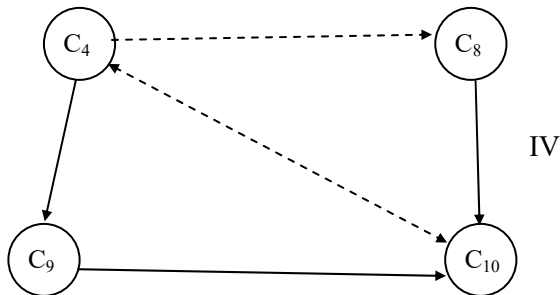

The neutrosophic connection matrix M_{IV} associated with graph IV is as follows:

$$M_{IV} = \begin{matrix} & \begin{matrix} c_4 & c_8 & c_9 & c_{10} \end{matrix} \\ \begin{matrix} c_4 \\ c_8 \\ c_9 \\ c_{10} \end{matrix} & \begin{bmatrix} 0 & I & 1 & I \\ 0 & 0 & 0 & I \\ 0 & 0 & 0 & 1 \\ I & 0 & 0 & 0 \end{bmatrix} \end{matrix} .$$

We cannot merge the graph I with III or IV.

Likewise graph II cannot be merged with graph IV. Further graph III cannot be merged with graph I. Finally graph IV cannot be merged with graphs I and II. We now get the merged neutrosophic graphs.

First let us get the merged NCMs of experts E_1 and E_2 by merging the neutrosophic graphs I and II.

Let A denote the merged graph of graphs I and II which is as follows.

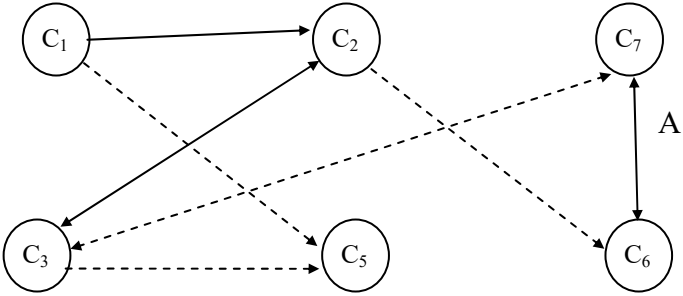

Let M_A denote the neutrosophic merged connection matrix of A.

$$M_A = \begin{matrix} & \begin{matrix} c_1 & c_2 & c_3 & c_5 & c_6 & c_7 \end{matrix} \\ \begin{matrix} c_1 \\ c_2 \\ c_3 \\ c_5 \\ c_6 \\ c_7 \end{matrix} & \begin{bmatrix} 0 & 1 & 0 & I & 0 & 0 \\ 0 & 0 & 1 & 0 & I & 0 \\ 0 & 1 & 0 & I & 0 & I \\ 0 & 0 & 0 & 0 & 0 & 0 \\ 0 & 0 & 0 & 0 & 0 & 1 \\ 0 & 0 & 0 & 0 & 1 & 0 \end{bmatrix} \end{matrix} .$$

Let B denote the merged graphs of the graphs II and III which is as follows:

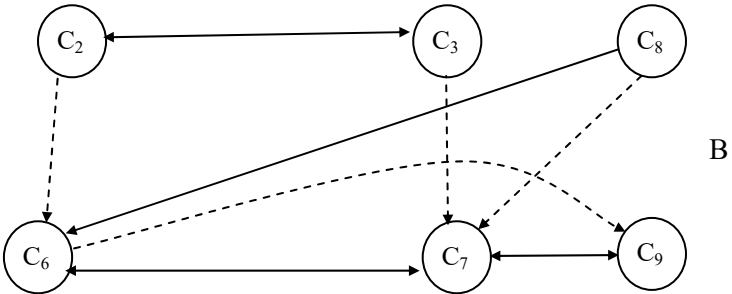

The merged neutrosophic connection matrix M_B of the graph B is as follows:

$$M_B = \begin{matrix} & c_2 & c_3 & c_6 & c_7 & c_8 & c_9 \\ \begin{matrix} c_2 \\ c_3 \\ c_6 \\ c_7 \\ c_8 \\ c_9 \end{matrix} & \begin{bmatrix} 0 & 1 & I & 0 & 0 & 0 \\ 1 & 0 & 0 & I & 0 & 0 \\ 0 & 0 & 0 & 1 & 0 & I \\ 0 & 0 & 1 & 0 & 0 & 1 \\ 0 & 0 & 1 & I & 0 & 0 \\ 0 & 0 & 0 & 1 & 0 & 0 \end{bmatrix} \end{matrix}.$$

Let C denote the merged neutrosophic graphs III and IV which is as follows:

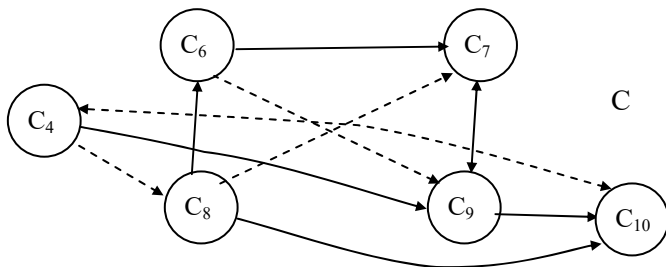

Let M_c denote the merged neutrosophic connection matrix of the merged neutrosophic graph C.

$$M_c = \begin{matrix} & c_4 & c_6 & c_7 & c_8 & c_9 & c_{10} \\ \begin{matrix} c_4 \\ c_6 \\ c_7 \\ c_8 \\ c_9 \\ c_{10} \end{matrix} & \begin{bmatrix} 0 & 0 & 0 & I & 1 & I \\ 0 & 0 & 1 & 0 & I & 0 \\ 0 & 0 & 0 & 0 & 1 & 0 \\ 0 & 1 & I & 0 & 0 & 1 \\ 0 & 0 & 1 & 0 & 0 & 1 \\ I & 0 & 0 & 0 & 0 & 0 \end{bmatrix} \end{matrix}.$$

Let D denote the merged graph of all the four neutrosophic graphs I, II, III and IV which is as follows:

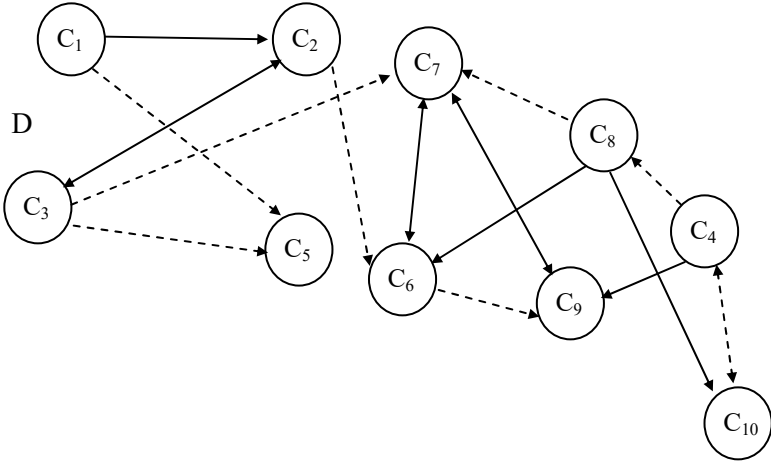

Let M_D denote the merged neutrosophic connection matrix of the merged neutrosophic directed graph D which is as follows:

$$M_D = \begin{matrix} & \begin{matrix} c_1 & c_2 & c_3 & c_4 & c_5 & c_6 & c_7 & c_8 & c_9 & c_{10} \end{matrix} \\ \begin{matrix} c_1 \\ c_2 \\ c_3 \\ c_4 \\ c_5 \\ c_6 \\ c_7 \\ c_8 \\ c_9 \\ c_{10} \end{matrix} & \begin{bmatrix} 0 & 1 & 0 & 0 & I & 0 & 0 & 0 & 0 & 0 \\ 0 & 0 & 1 & 0 & 0 & I & 0 & 0 & 0 & 0 \\ 0 & 1 & 0 & 0 & I & 0 & I & 0 & 0 & 0 \\ 0 & 0 & 0 & 0 & 0 & 0 & 0 & I & 1 & I \\ 0 & 0 & 0 & 0 & 0 & 0 & 0 & 0 & 0 & 0 \\ 0 & 0 & 0 & 0 & 0 & 0 & 1 & 0 & I & 0 \\ 0 & 0 & 0 & 0 & 0 & 1 & 0 & 0 & 1 & 0 \\ 0 & 0 & 0 & 0 & 0 & 1 & I & 0 & 0 & 1 \\ 0 & 0 & 0 & 0 & 0 & 0 & 1 & 0 & 0 & 0 \\ 0 & 0 & 0 & I & 0 & 0 & 0 & 0 & 0 & 0 \end{bmatrix} \end{matrix} .$$

This is the way specially linked merged NCMs function.

Now we proceed onto describe the notion of specially linked (merged) NCMs. Suppose we have some n concepts say $\{c_1, c_2, \dots, c_n\}$ and say t experts work on it and all of them use only NCMs .

Now we proceed onto describe the specially merged NCMs model using groups of experts from the t experts.

Suppose say r_1 of the experts from the t experts give the total or integrated model. If we have another set of r_2 experts from t experts give the total or integrated model so on say some r_i of the t experts give the integrated model then to find the most influential expert and the least influential expert.

Most influential expert is one who cannot be compensated or replaced by some other expert.

A passive or a weak expert is one who can be replaced by one or more experts. This has been described developed in the case of FCMs.

Now we will describe the situation by an example.

Let $C = \{C_1, C_2, \dots, C_{10}\}$ be the ten concepts associated with a problem. Let E_1, E_2, E_3, E_4, E_5 be 5 experts working on this problem using NCMs by selecting some attributes from the set C . Suppose the expert E_1 works with the attributes $\{C_1, C_3, C_4, C_5\}$ and the expert E_2 works with the attributes $\{C_5, C_4, C_2, C_7\}$. The third expert E_3 works with the attributes $\{C_6, C_9, C_8, C_{10}\}$.

The forth expert works with $\{C_1, C_2, C_7$ and $C_6\}$ and the fifth expert works with $\{C_2, C_5, C_1, C_4\}$.

Now we see $\{C_1, C_3, C_4, C_5\} \cup \{C_5, C_4, C_2, C_7\} \cup \{C_6, C_9, C_8, C_{10}\} = C$.

However the set $\{C_5, C_4, C_2, C_7\}$ is replaced by $\{C_1, C_2, C_7, C_6\}$ and still we get C .

However the sets $\{C_1, C_3, C_4, C_5\}$ and $\{C_6, C_8, C_9, C_{10}\}$ cannot be replaced by any other set. We can as in case of FCMs get the merged connection neutrosophic matrix of the merged neutrosophic cognitive maps model.

It is pertinent to keep on record that all the five experts work only with the NCMs.

Finally we describe the mixed FCMs and NCMs model. Suppose we have a problem which is associated with n attributes say $C = \{c_1, \dots, c_n\}$. Some s experts agree to work on the problem using some attributes from the set C using only the FCMs model. Some t expert wish to work on the problem using some attributes from the set C using the NCMs model only. Thus these $t + s$ number of experts alone can contribute for the integrated merged mixed FCMs and NCMs model.

That is all the s -experts do not cover the set of n attributes neither the set of t -experts cover the set of all n -attributes only a subcollection from the s -experts and the t -experts alone are in a positive to cover all n concepts in C .

Thus we are forced to merge a directed graph with a directed neutrosophic graph to arrive at a solution. The resultant model will be defined as the mixed merged FCMs and NCMs model.

This will be illustrated by the following example.

Let $C = \{C_1, C_2, C_3, \dots, C_{10}\}$ be the set of 10 attributes. Suppose 3 experts choose to work with the problem with some nodes from the set C using only NCMs model. Some 2 experts work the problem with some nodes from C using only the FCMs model. Thus 5 experts E_1, E_2, \dots, E_5 work on the problem.

Let the three experts E_1, E_2 and E_3 work with the NCMs and the experts E_4 and E_5 work with the FCMs model.

Let the first expert E_1 work with the concepts $\{C_1, C_2, C_4, C_5\}$ and the second expert E_2 work with the nodes $\{C_6, C_3, C_7, C_9\}$. The third expert E_3 works with the nodes $\{C_4, C_5, C_6, C_9\}$. Thus all the three experts work only with the NCMs model.

Let the forth experts E_4 work with the nodes $\{C_1, C_2, C_3, C_8, C_9\}$ and the expert E_5 work with the nodes $\{C_4, C_5, C_{10}, C_7, C_2\}$.

In the first place we observe even when all the three experts E_1, E_2 and E_3 join together to get the merged NCMs still the nodes C_8 and C_{10} are left out from the set C .

Now it is also observed that two experts E_4 and E_5 cannot give in the merged FCMs model accounting for all the nodes from C .

They also cannot account for C_6 , for C_6 is missing. Thus we to get whole of C define the merged mixed FCMs and NCMs model.

Now let A be the neutrosophic graph associated with the first expert E_1 which is as follows.

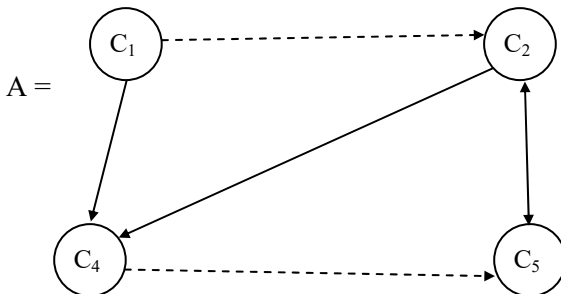

Let B be the directed neutrosophic graph given by second expert E_2 .

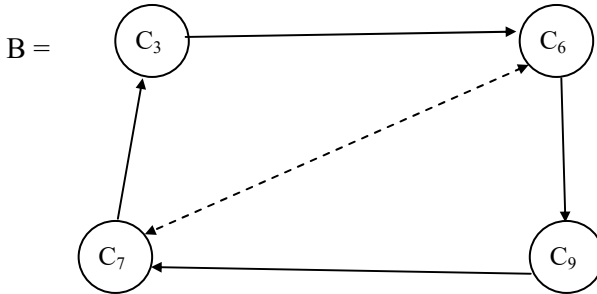

Let C be the directed neutrosophic graph given by the third expert E_3 which is as follows:

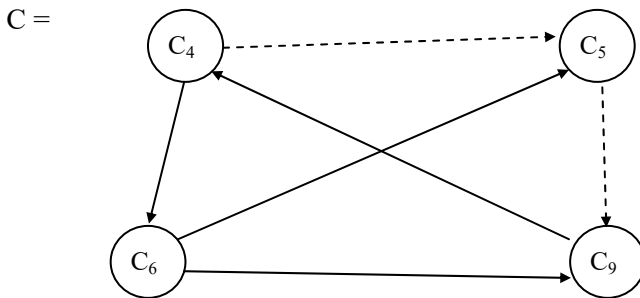

Let D be the directed graph given by the fourth expert E_4 which is as follows:

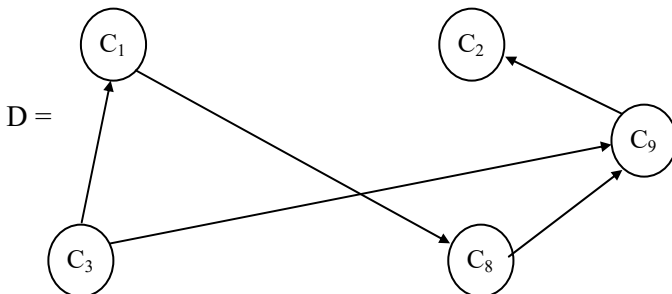

Let E be the directed graph of the FCMs model given by the fifth expert E₅.

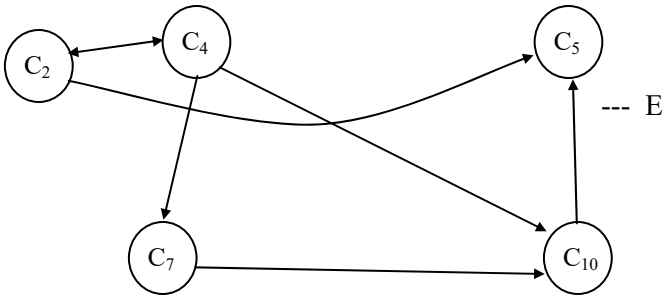

Now the connection matrix of the neutrosophic graph A be M_A which is as follows:

$$M_A = \begin{matrix} & c_1 & c_2 & c_4 & c_5 \\ \begin{matrix} c_1 \\ c_2 \\ c_4 \\ c_5 \end{matrix} & \begin{bmatrix} 0 & 1 & 1 & 0 \\ 0 & 0 & 1 & 1 \\ 0 & 0 & 0 & 1 \\ 0 & 1 & 0 & 0 \end{bmatrix} \end{matrix} .$$

Let M_B be the connection matrix associated with the neutrosophic directed graph given by the second expert which is as follows:

$$M_B = \begin{matrix} & c_3 & c_6 & c_7 & c_9 \\ \begin{matrix} c_3 \\ c_6 \\ c_7 \\ c_9 \end{matrix} & \begin{bmatrix} 0 & 1 & 0 & 0 \\ 0 & 0 & 1 & 1 \\ 1 & 1 & 0 & 0 \\ 0 & 0 & 1 & 0 \end{bmatrix} \end{matrix} .$$

Let M_c denote the connection neutrosophic matrix associated with the neutrosophic graph C.

$$M_c = \begin{matrix} & c_4 & c_5 & c_6 & c_9 \\ \begin{matrix} c_4 \\ c_5 \\ c_6 \\ c_9 \end{matrix} & \begin{bmatrix} 0 & 1 & 1 & 0 \\ 0 & 0 & 0 & 1 \\ 0 & 1 & 0 & 1 \\ 1 & 0 & 0 & 0 \end{bmatrix} \end{matrix}.$$

Let M_D denote the connection matrix of the directed graph D given by the fourth expert E_4 which is as follows:

$$M_D = \begin{matrix} & c_1 & c_2 & c_3 & c_8 & c_9 \\ \begin{matrix} c_1 \\ c_2 \\ c_3 \\ c_8 \\ c_9 \end{matrix} & \begin{bmatrix} 0 & 0 & 0 & 1 & 0 \\ 0 & 0 & 0 & 0 & 0 \\ 1 & 0 & 0 & 0 & 1 \\ 0 & 0 & 0 & 0 & 1 \\ 0 & 1 & 0 & 0 & 0 \end{bmatrix} \end{matrix}.$$

Let M_E denote the connection matrix of the directed graph E given by the fifth expert E_5 .

$$M_E = \begin{matrix} & c_2 & c_4 & c_5 & c_7 & c_{10} \\ \begin{matrix} c_2 \\ c_4 \\ c_5 \\ c_7 \\ c_{10} \end{matrix} & \begin{bmatrix} 0 & 1 & 1 & 0 & 0 \\ 1 & 0 & 0 & 1 & 1 \\ 0 & 0 & 0 & 0 & 0 \\ 0 & 0 & 0 & 0 & 1 \\ 0 & 0 & 1 & 0 & 0 \end{bmatrix} \end{matrix}.$$

Now let F give the merged graph of the first two experts E_1 and E_2 which is as follows:

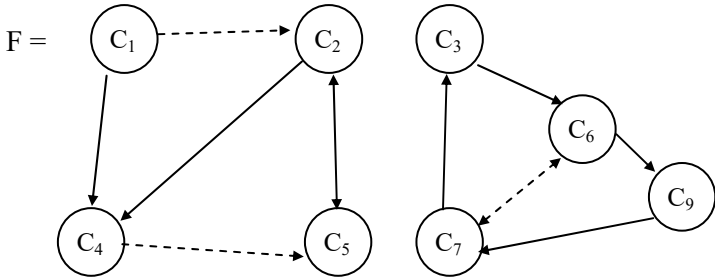

We see the graphs A and B cannot be merged to a graph so F does not exist as the graphs have no common vertex or edge.

Let G denote the merged graph of the experts 1 and 3 which is as follows:

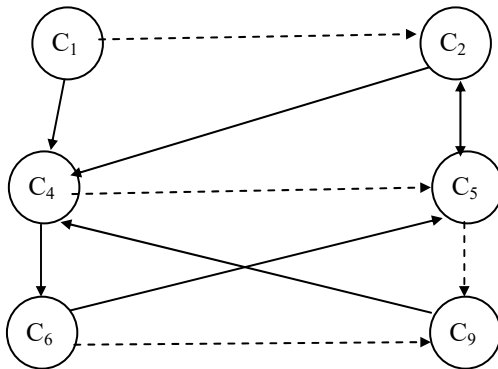

The merged graph G is a neutrosophic graph.

Let M_G be the connection matrix of G .

$$M_G = \begin{matrix} & c_1 & c_2 & c_4 & c_5 & c_6 & c_9 \\ \begin{matrix} c_1 \\ c_2 \\ c_4 \\ c_5 \\ c_6 \\ c_9 \end{matrix} & \begin{bmatrix} 0 & I & 1 & 0 & 0 & 0 \\ 0 & 0 & 1 & 1 & 0 & 0 \\ 0 & 0 & 0 & I & 1 & 0 \\ 0 & 1 & 0 & 0 & 0 & I \\ 0 & 0 & 0 & 1 & 0 & I \\ 0 & 0 & 1 & 0 & 0 & 0 \end{bmatrix} \end{matrix} .$$

The merged graph H of experts 1 and 4 is as follows:

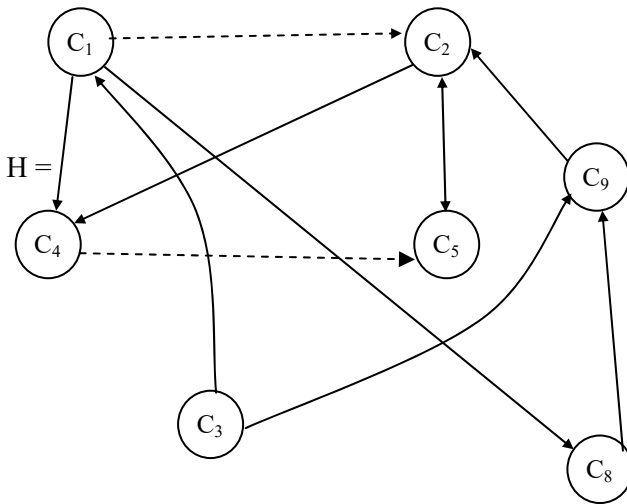

Let M_H be the connection matrix of the merged graph H.

$$M_H = \begin{matrix} & c_1 & c_2 & c_3 & c_4 & c_5 & c_8 & c_9 \\ \begin{matrix} c_1 \\ c_2 \\ c_3 \\ c_4 \\ c_5 \\ c_8 \\ c_9 \end{matrix} & \begin{bmatrix} 0 & 1 & 0 & 1 & 0 & 1 & 0 \\ 0 & 0 & 0 & 1 & 1 & 0 & 0 \\ 1 & 0 & 0 & 0 & 0 & 0 & 1 \\ 0 & 0 & 0 & 0 & 1 & 0 & 0 \\ 0 & 1 & 0 & 0 & 0 & 0 & 0 \\ 0 & 0 & 0 & 0 & 0 & 0 & 1 \\ 0 & 1 & 0 & 0 & 0 & 0 & 0 \end{bmatrix} \end{matrix} .$$

Let I denote the merged graph of the experts (1) and (5) which is as follows:

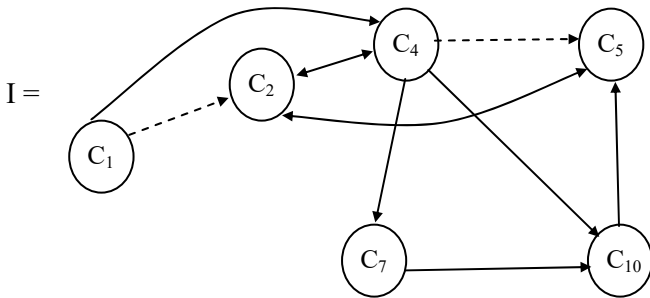

Let M_I denote the connection matrix of the merged graph I which is as follows:

$$M_I = \begin{matrix} & c_1 & c_2 & c_4 & c_5 & c_7 & c_{10} \\ \begin{matrix} c_1 \\ c_2 \\ c_4 \\ c_5 \\ c_7 \\ c_{10} \end{matrix} & \begin{bmatrix} 0 & 1 & 1 & 0 & 0 & 0 \\ 0 & 0 & 1 & 1 & 0 & 0 \\ 0 & 1 & 0 & 1 & 1 & 1 \\ 0 & 1 & 0 & 0 & 0 & 0 \\ 0 & 0 & 0 & 0 & 0 & 1 \\ 0 & 0 & 0 & 1 & 0 & 0 \end{bmatrix} \end{matrix} .$$

The merged graph J of experts 2 and 3 are as follows:

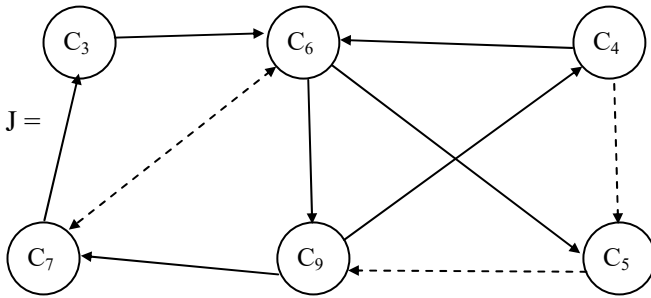

The merged connection matrix M_J of the merged graph J is as follows:

$$M_J = \begin{matrix} & \begin{matrix} c_3 & c_4 & c_5 & c_6 & c_7 & c_9 \end{matrix} \\ \begin{matrix} c_3 \\ c_4 \\ c_5 \\ c_6 \\ c_7 \\ c_9 \end{matrix} & \begin{bmatrix} 0 & 0 & 0 & 1 & 0 & 0 \\ 0 & 0 & 1 & 1 & 0 & 0 \\ 0 & 0 & 0 & 0 & 0 & 1 \\ 0 & 0 & 1 & 0 & 1 & 1 \\ 1 & 0 & 0 & 1 & 0 & 0 \\ 0 & 1 & 0 & 0 & 1 & 0 \end{bmatrix} \end{matrix} .$$

Now we get the merged graph K given by the experts 2 and 4 which is as follows:

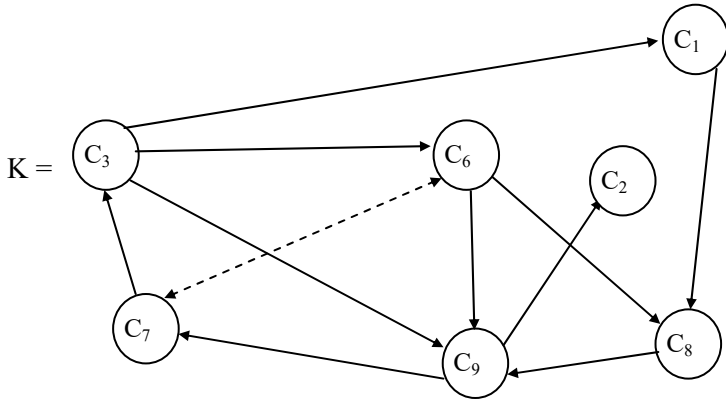

The merged connection matrix M_K of the directed graph K is as follows:

$$M_K = \begin{matrix} & c_1 & c_2 & c_3 & c_6 & c_7 & c_8 & c_9 \\ \begin{matrix} c_1 \\ c_2 \\ c_3 \\ c_6 \\ c_7 \\ c_8 \\ c_9 \end{matrix} & \begin{bmatrix} 0 & 0 & 0 & 0 & 0 & 1 & 0 \\ 0 & 0 & 0 & 0 & 0 & 0 & 0 \\ 1 & 0 & 0 & 1 & 0 & 0 & 1 \\ 0 & 0 & 0 & 0 & 1 & 0 & 1 \\ 0 & 0 & 1 & 1 & 0 & 0 & 0 \\ 0 & 0 & 0 & 0 & 0 & 0 & 1 \\ 0 & 1 & 0 & 0 & 1 & 0 & 0 \end{bmatrix} \end{matrix} .$$

Let L denote the merged graph given by the experts 2 and 5 which is as follows:

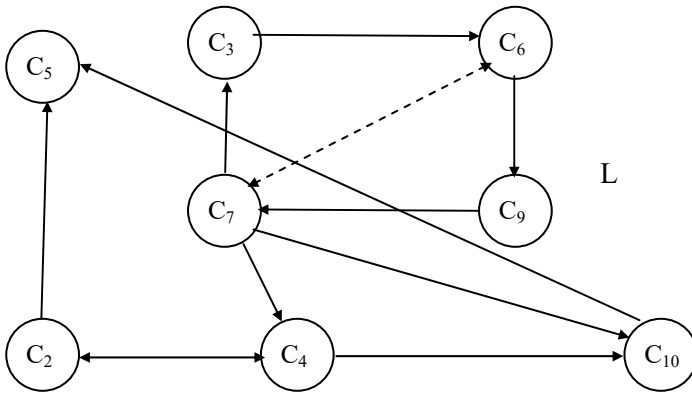

The merged connection matrix M_L of the neutrosophic merged graph L is as follows:

$$M_L = \begin{matrix} & c_2 & c_3 & c_4 & c_5 & c_6 & c_7 & c_9 & c_{10} \\ \begin{matrix} c_2 \\ c_3 \\ c_4 \\ c_5 \\ c_6 \\ c_7 \\ c_9 \\ c_{10} \end{matrix} & \begin{bmatrix} 0 & 0 & 1 & 1 & 0 & 0 & 0 & 0 \\ 0 & 0 & 0 & 0 & 1 & 0 & 0 & 0 \\ 1 & 0 & 0 & 0 & 0 & 0 & 0 & 1 \\ 0 & 0 & 0 & 0 & 0 & 0 & 0 & 0 \\ 0 & 0 & 0 & 0 & 0 & 1 & 1 & 0 \\ 0 & 1 & 1 & 0 & 1 & 0 & 0 & 1 \\ 0 & 0 & 0 & 0 & 0 & 1 & 0 & 0 \\ 0 & 0 & 0 & 1 & 0 & 0 & 0 & 0 \end{bmatrix} & . \end{matrix}$$

Let M denote the merged graph of the experts 3 and 4 which is as follows:

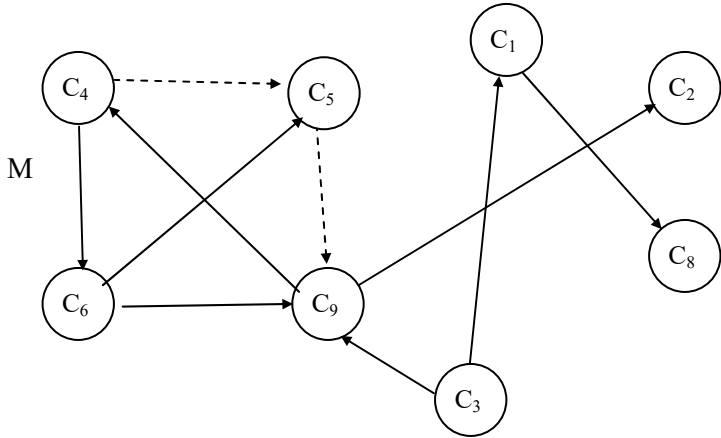

Let M_M be the merged neutrosophic connection matrix of the merged neutrosophic graph M which is as follows:

$$M_M = \begin{matrix} & \begin{matrix} c_1 & c_2 & c_3 & c_4 & c_5 & c_6 & c_8 & c_9 \end{matrix} \\ \begin{matrix} c_1 \\ c_2 \\ c_3 \\ c_4 \\ c_5 \\ c_6 \\ c_8 \\ c_9 \end{matrix} & \begin{bmatrix} 0 & 0 & 0 & 0 & 0 & 0 & 1 & 0 \\ 0 & 0 & 0 & 0 & 0 & 0 & 0 & 0 \\ 1 & 0 & 0 & 0 & 0 & 0 & 0 & 1 \\ 0 & 0 & 0 & 0 & I & 1 & 0 & 0 \\ 0 & 0 & 0 & 0 & 0 & 0 & 0 & I \\ 0 & 0 & 0 & 0 & 1 & 0 & 0 & 1 \\ 0 & 0 & 0 & 0 & 0 & 0 & 0 & 0 \\ 0 & 1 & 0 & 1 & 0 & 0 & 0 & 0 \end{bmatrix} \end{matrix}$$

Let N denoted the merged neutrosophic graphs of the experts 3 and 5.

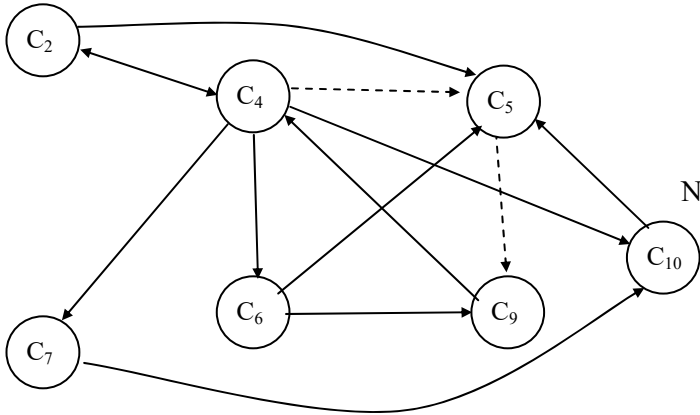

Let M_N be the merged neutrosophic connection matrix of the merged neutrosophic graph N which is as follows:

$$M_N = \begin{matrix} & c_2 & c_4 & c_5 & c_6 & c_7 & c_9 & c_{10} \\ \begin{matrix} c_2 \\ c_4 \\ c_5 \\ c_6 \\ c_7 \\ c_9 \\ c_{10} \end{matrix} & \begin{bmatrix} 0 & 1 & 1 & 0 & 0 & 0 & 0 \\ 1 & 0 & I & 1 & 1 & 0 & 1 \\ 0 & 0 & 0 & 0 & 0 & I & 0 \\ 0 & 0 & 1 & 0 & 0 & 1 & 0 \\ 0 & 0 & 0 & 0 & 0 & 0 & 1 \\ 0 & 1 & 0 & 0 & 0 & 0 & 0 \\ 0 & 0 & 1 & 0 & 0 & 0 & 0 \end{bmatrix} & . \end{matrix}$$

Let O denote the merged graph given by the experts 4 and 5 which is as follows:

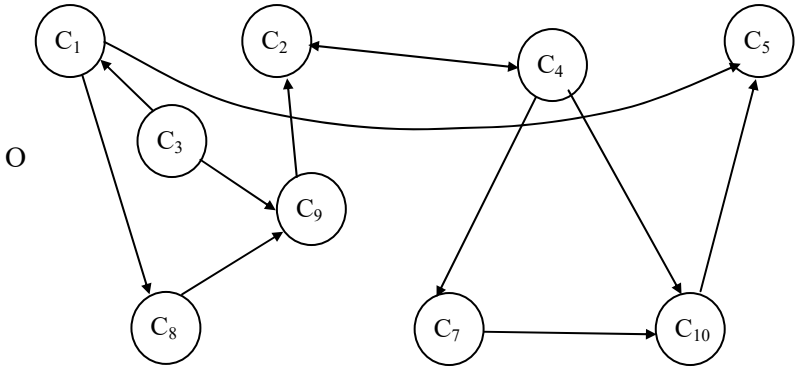

We see the merged graph is not a neutrosophic graph. Infact a usual graph.

Hence the related connection merged matrix M_o of O will not be a neutrosophic graph.

Hence the merged graph of these two expert also work with the FCM and not a NCM.

Only when one of them works with a neutrosophic graph and other the usual graph we will get a merged neutrosophic graph hence the merged connection matrix is also a neutrosophic matrix forcing the dynamical system associated with it to be a NCM and not a FCM.

We now give the connection matrix M_o of the merged graph O which as follows:

$$M_0 = \begin{matrix} & c_1 & c_2 & c_3 & c_4 & c_5 & c_7 & c_8 & c_9 & c_{10} \\ \begin{matrix} c_1 \\ c_2 \\ c_3 \\ c_4 \\ c_5 \\ c_7 \\ c_8 \\ c_9 \\ c_{10} \end{matrix} & \begin{bmatrix} 0 & 0 & 0 & 0 & 1 & 0 & 1 & 0 & 0 \\ 0 & 0 & 0 & 1 & 0 & 0 & 0 & 0 & 0 \\ 1 & 0 & 0 & 0 & 0 & 0 & 0 & 0 & 1 \\ 0 & 1 & 0 & 0 & 0 & 1 & 0 & 0 & 1 \\ 0 & 0 & 0 & 0 & 0 & 0 & 0 & 0 & 0 \\ 0 & 0 & 0 & 0 & 0 & 0 & 0 & 0 & 1 \\ 0 & 0 & 0 & 0 & 0 & 0 & 0 & 1 & 0 \\ 0 & 1 & 0 & 0 & 0 & 0 & 0 & 0 & 0 \\ 0 & 0 & 0 & 0 & 1 & 0 & 0 & 0 & 0 \end{bmatrix} \end{matrix}.$$

We see this merged model is only a merged FCMs model. All nodes except C_6 is present. We can also merge the directed graphs of the experts 1, 2 and 4.

Let the merged graph of the experts 1, 2 and 3 be denoted by P which is as follows.

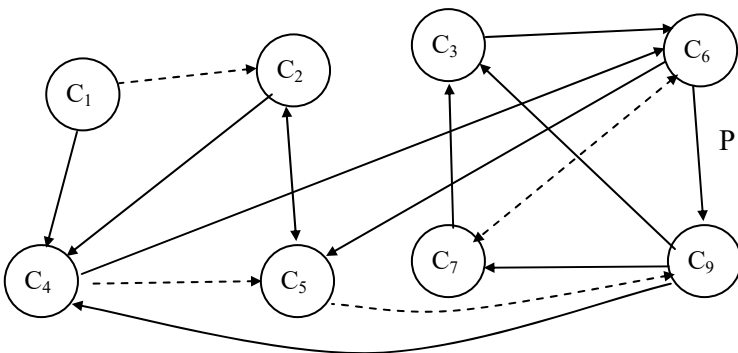

The merged connection matrix M_P of P is as follows:

$$M_P = \begin{matrix} & c_1 & c_2 & c_3 & c_4 & c_5 & c_6 & c_7 & c_9 \\ \begin{matrix} c_1 \\ c_2 \\ c_3 \\ c_4 \\ c_5 \\ c_6 \\ c_7 \\ c_9 \end{matrix} & \begin{bmatrix} 0 & I & 0 & 1 & 0 & 0 & 0 & 0 \\ 0 & 0 & 0 & 1 & 1 & 0 & 0 & 0 \\ 0 & 0 & 0 & 0 & 0 & 1 & 0 & 0 \\ 0 & 0 & 0 & 0 & I & 1 & 0 & 0 \\ 0 & 1 & 0 & 0 & 0 & 0 & 0 & I \\ 0 & 0 & 0 & 0 & 1 & 0 & I & 1 \\ 0 & 0 & 1 & 0 & 0 & I & 0 & 0 \\ 0 & 0 & 1 & 1 & 0 & 0 & 1 & 0 \end{bmatrix} \end{matrix} .$$

Let Q denote the merged graph of the expert 1, 2 and 4 which is as follows:

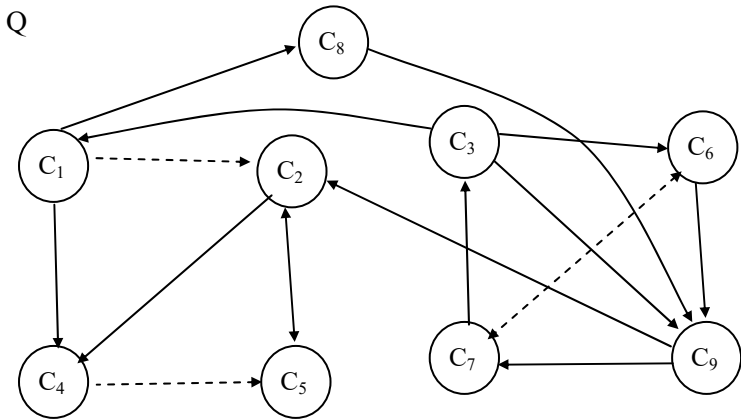

Let M_Q denote the merged connection matrix of the merged graph Q.

$$M_Q = \begin{matrix} & c_1 & c_2 & c_3 & c_4 & c_5 & c_6 & c_7 & c_8 & c_9 \\ \begin{matrix} c_1 \\ c_2 \\ c_3 \\ c_4 \\ c_5 \\ c_6 \\ c_7 \\ c_8 \\ c_9 \end{matrix} & \begin{bmatrix} 0 & I & 0 & 1 & 0 & 0 & 0 & 1 & 0 \\ 0 & 0 & 0 & 1 & 1 & 0 & 0 & 0 & 0 \\ 1 & 0 & 0 & 0 & 0 & 1 & 0 & 0 & 1 \\ 0 & 0 & 0 & 0 & I & 0 & 0 & 0 & 0 \\ 0 & 1 & 0 & 0 & 0 & 0 & 0 & 0 & 0 \\ 0 & 0 & 0 & 0 & 0 & 0 & I & 0 & 1 \\ 0 & 0 & 1 & 0 & 0 & I & 0 & 0 & 0 \\ 0 & 0 & 0 & 0 & 0 & 0 & 0 & 0 & 1 \\ 0 & 1 & 0 & 0 & 0 & 0 & 1 & 0 & 0 \end{bmatrix} \end{matrix}.$$

Let R denote the merged graph of the experts 1, 2 and 5 which is as follows.

Let R denote the merged graph of the experts 1, 2 and 5 which is as follows:

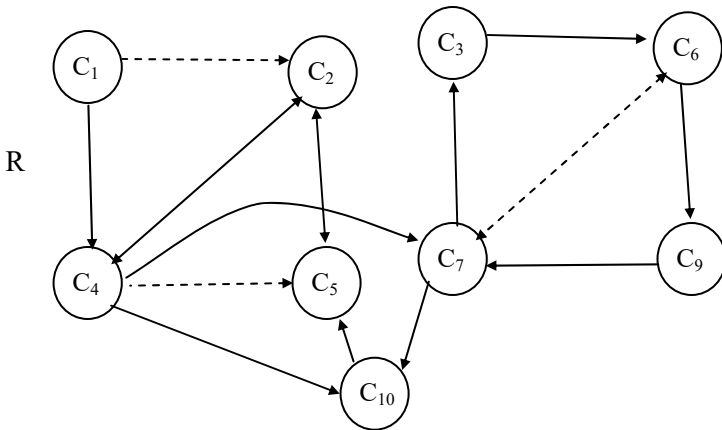

Let M_R denote the merged connection matrix of the graph R which is as follows:

$$M_R = \begin{matrix} & c_1 & c_2 & c_3 & c_4 & c_5 & c_6 & c_7 & c_9 & c_{10} \\ \begin{matrix} c_1 \\ c_2 \\ c_3 \\ c_4 \\ c_5 \\ c_6 \\ c_7 \\ c_9 \\ c_{10} \end{matrix} & \begin{bmatrix} 0 & 1 & 0 & 1 & 0 & 0 & 0 & 0 & 0 \\ 0 & 0 & 0 & 1 & 1 & 0 & 0 & 0 & 0 \\ 0 & 0 & 0 & 0 & 0 & 1 & 0 & 0 & 0 \\ 0 & 1 & 0 & 0 & 1 & 0 & 1 & 0 & 1 \\ 0 & 1 & 0 & 0 & 0 & 0 & 0 & 0 & 0 \\ 0 & 0 & 0 & 0 & 0 & 0 & 1 & 1 & 0 \\ 0 & 0 & 1 & 0 & 0 & 1 & 0 & 0 & 1 \\ 0 & 0 & 0 & 0 & 0 & 0 & 1 & 0 & 0 \\ 0 & 0 & 0 & 0 & 1 & 0 & 0 & 0 & 0 \end{bmatrix} \end{matrix}.$$

Let S denote the merged graph of the experts 1, 3 and 4 which as follows:

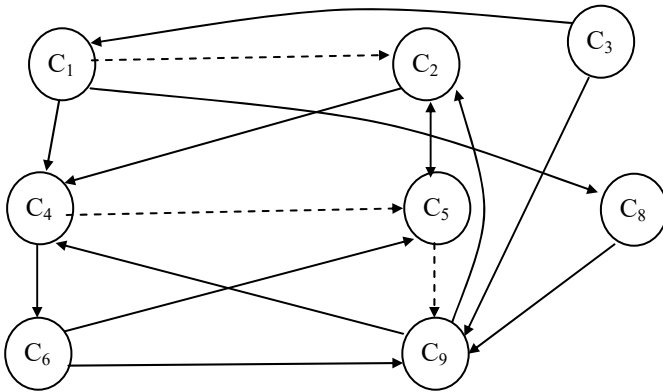

Let M_s denote the merged connection matrix of the merged graph S which is as follows:

$$M_S = \begin{matrix} & c_1 & c_2 & c_3 & c_4 & c_5 & c_6 & c_8 & c_9 \\ \begin{matrix} c_1 \\ c_2 \\ c_3 \\ c_4 \\ c_5 \\ c_6 \\ c_8 \\ c_9 \end{matrix} & \begin{bmatrix} 0 & I & 0 & 1 & 0 & 0 & 1 & 0 \\ 0 & 0 & 0 & 1 & 1 & 0 & 0 & 0 \\ 1 & 0 & 0 & 0 & 0 & 0 & 0 & 1 \\ 0 & 0 & 0 & 0 & I & 1 & 0 & 0 \\ 0 & 1 & 0 & 0 & 0 & 0 & 0 & I \\ 0 & 0 & 0 & 0 & 1 & 0 & 0 & 1 \\ 0 & 0 & 0 & 0 & 0 & 0 & 0 & 1 \\ 0 & 1 & 0 & 0 & 0 & 0 & 0 & 0 \end{bmatrix} \end{matrix} .$$

Let T denote the merged graph of the experts 1, 3 and 5 which is as follows:

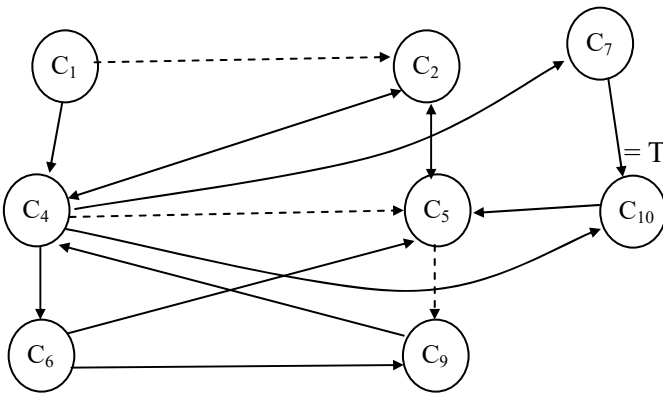

Let M_T denote the merged connection matrix of the merged graph T which is as follows:

$$M_T = \begin{matrix} & c_1 & c_2 & c_4 & c_5 & c_6 & c_7 & c_9 & c_{10} \\ \begin{matrix} c_1 \\ c_2 \\ c_4 \\ c_5 \\ c_6 \\ c_7 \\ c_9 \\ c_{10} \end{matrix} & \begin{bmatrix} 0 & 1 & 1 & 0 & 0 & 0 & 0 & 0 \\ 0 & 0 & 1 & 1 & 0 & 0 & 0 & 0 \\ 0 & 1 & 0 & 0 & 1 & 1 & 0 & 1 \\ 0 & 1 & 0 & 0 & 0 & 0 & 1 & 0 \\ 0 & 0 & 0 & 1 & 0 & 0 & 1 & 0 \\ 0 & 0 & 0 & 0 & 0 & 0 & 0 & 1 \\ 0 & 1 & 0 & 1 & 0 & 0 & 0 & 0 \\ 0 & 0 & 0 & 1 & 0 & 0 & 0 & 0 \end{bmatrix} & . \end{matrix}$$

Let U denote the merged graph of the graphs given by the experts 1, 4 and 5 which is as follows:

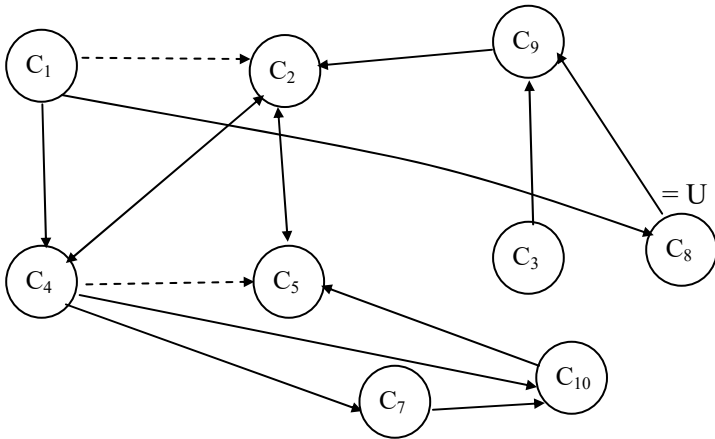

Let M_U denote the merged neutrosophic connection matrix of the merged graph U which is as follows:

$$M_U = \begin{matrix} & c_1 & c_2 & c_3 & c_4 & c_5 & c_7 & c_8 & c_9 & c_{10} \\ \begin{matrix} c_1 \\ c_2 \\ c_3 \\ c_4 \\ c_5 \\ c_7 \\ c_8 \\ c_9 \\ c_{10} \end{matrix} & \begin{bmatrix} 0 & I & 0 & 1 & 0 & 0 & 1 & 0 & 0 \\ 0 & 0 & 0 & 1 & 1 & 0 & 0 & 0 & 0 \\ 0 & 0 & 0 & 0 & 0 & 0 & 0 & 0 & 1 & 0 \\ 0 & 1 & 0 & 0 & I & 1 & 0 & 0 & 1 \\ 0 & 0 & 0 & 0 & 0 & 0 & 0 & 0 & 0 & 0 \\ 0 & 0 & 0 & 0 & 0 & 0 & 0 & 0 & 0 & 1 \\ 0 & 0 & 0 & 0 & 0 & 0 & 0 & 0 & 1 & 0 \\ 0 & 1 & 0 & 0 & 0 & 0 & 0 & 0 & 0 & 0 \\ 0 & 0 & 0 & 0 & 1 & 0 & 0 & 0 & 0 & 0 \end{bmatrix} \end{matrix}.$$

However M_0 and M_U are distinct one is a FCM model and other is a NCM model. Let V denote the merged graph of the experts 2, 3 and 4 which is as follows:

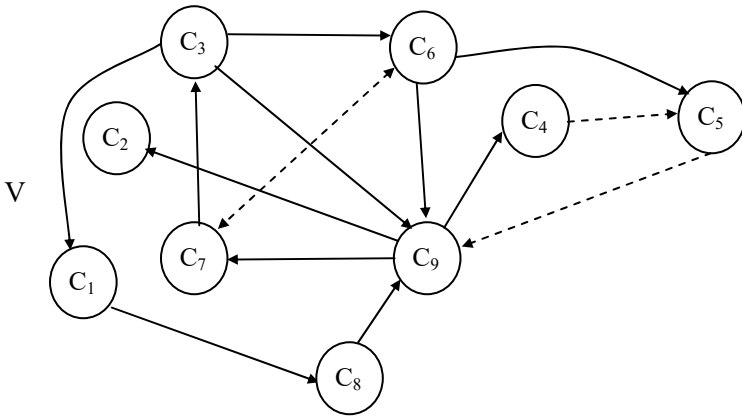

The merged connection matrix M_V associated with neutrosophic directed graph V is as follows:

$$M_V = \begin{matrix} & c_1 & c_2 & c_3 & c_4 & c_5 & c_6 & c_7 & c_8 & c_9 \\ \begin{matrix} c_1 \\ c_2 \\ c_3 \\ c_4 \\ c_5 \\ c_6 \\ c_7 \\ c_8 \\ c_9 \end{matrix} & \begin{bmatrix} 0 & 0 & 0 & 0 & 0 & 0 & 0 & 1 & 0 \\ 0 & 0 & 0 & 0 & 0 & 0 & 0 & 0 & 0 \\ 1 & 0 & 0 & 0 & 0 & 1 & 0 & 0 & 1 \\ 0 & 0 & 0 & 0 & I & 0 & 0 & 0 & 0 \\ 0 & 0 & 0 & 0 & 0 & 0 & 0 & 0 & I \\ 0 & 0 & 0 & 0 & I & 0 & I & 0 & 1 \\ 0 & 0 & 1 & 0 & 0 & I & 0 & 0 & 0 \\ 0 & 0 & 0 & 0 & 0 & 0 & 0 & 0 & 1 \\ 0 & 1 & 0 & 1 & 0 & 0 & 1 & 0 & 0 \end{bmatrix} \end{matrix}.$$

Next let W denote the merged graph given by the experts 2, 3 and 5 which is as follows:

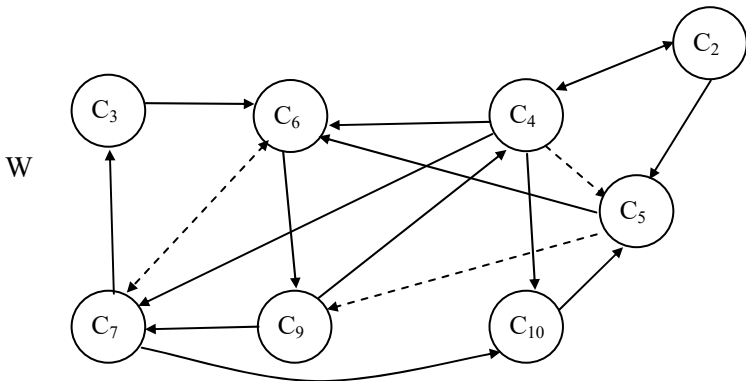

Let M_W denote the merged connection neutrosophic matrix of the merged graph W which is as follows:

$$M_W = \begin{matrix} & c_2 & c_3 & c_4 & c_5 & c_6 & c_7 & c_9 & c_{10} \\ \begin{matrix} c_2 \\ c_3 \\ c_4 \\ c_5 \\ c_6 \\ c_7 \\ c_9 \\ c_{10} \end{matrix} & \begin{bmatrix} 0 & 0 & 1 & 1 & 0 & 0 & 0 & 0 \\ 0 & 0 & 0 & 0 & 1 & 0 & 0 & 0 \\ 1 & 0 & 0 & 1 & 1 & 1 & 0 & 1 \\ 0 & 0 & 0 & 0 & 1 & 0 & 1 & 0 \\ 0 & 0 & 0 & 0 & 0 & 1 & 1 & 0 \\ 0 & 0 & 1 & 0 & 1 & 0 & 0 & 1 \\ 0 & 0 & 0 & 1 & 0 & 1 & 0 & 0 \\ 0 & 0 & 0 & 1 & 0 & 0 & 0 & 0 \end{bmatrix} \end{matrix} .$$

Next let X denote the merged graph given by the experts 3, 4, 5 which is as follows:

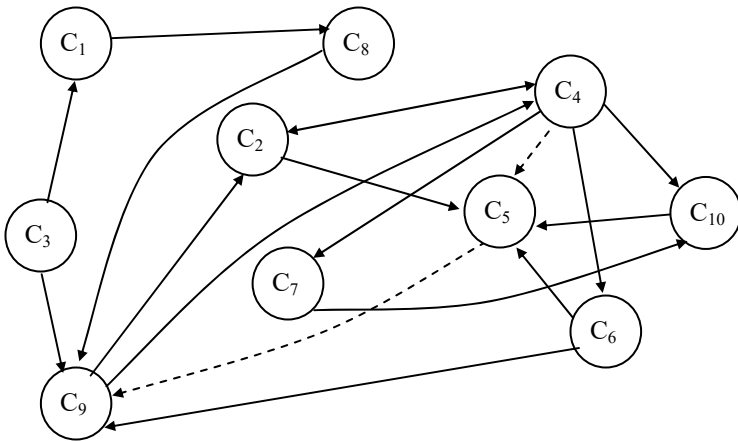

Let M_X denote the merged connection matrix of the merged graph X which is as follows:

$$M_X = \begin{matrix} & c_1 & c_2 & c_3 & c_4 & c_5 & c_6 & c_7 & c_8 & c_9 & c_{10} \\ \begin{matrix} c_1 \\ c_2 \\ c_3 \\ c_4 \\ c_5 \\ c_6 \\ c_7 \\ c_8 \\ c_9 \\ c_{10} \end{matrix} & \begin{bmatrix} 0 & 0 & 0 & 0 & 0 & 0 & 0 & 1 & 0 & 0 \\ 0 & 0 & 0 & 1 & 1 & 0 & 0 & 0 & 0 & 0 \\ 1 & 0 & 0 & 0 & 0 & 0 & 0 & 0 & 1 & 0 \\ 0 & 1 & 0 & 0 & 1 & 1 & 1 & 0 & 0 & 1 \\ 0 & 0 & 0 & 0 & 0 & 0 & 0 & 0 & 1 & 0 \\ 0 & 0 & 0 & 0 & 1 & 0 & 0 & 0 & 1 & 0 \\ 0 & 0 & 0 & 0 & 0 & 0 & 0 & 0 & 0 & 1 \\ 0 & 0 & 0 & 0 & 0 & 0 & 0 & 0 & 1 & 0 \\ 0 & 1 & 0 & 1 & 0 & 0 & 0 & 0 & 0 & 0 \\ 0 & 0 & 0 & 0 & 1 & 0 & 0 & 0 & 0 & 0 \end{bmatrix} \end{matrix}.$$

This merged graph X gives the complete merged NCM model of all the 10 attributes. So we see three experts are sufficient to make up for the integrated NCMs model.

We now find the merged graph Y given by the experts 1, 2, 3 and 4 which is as follows:

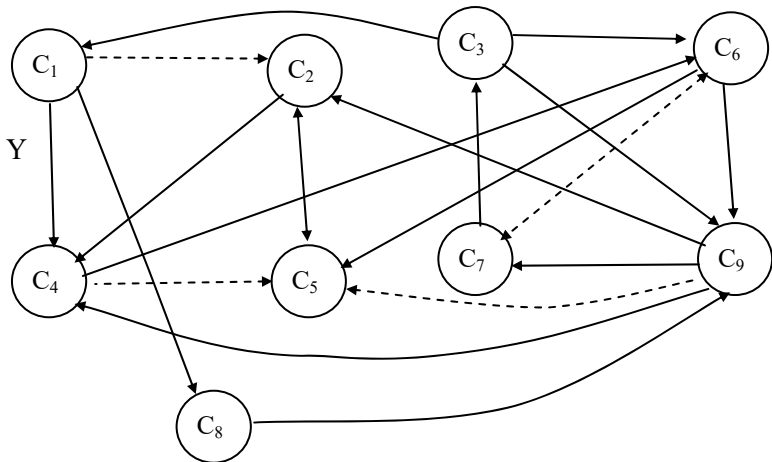

Let M_Y denote the merged connection matrix of the merged graph Y which is as follows:

$$M_Y = \begin{matrix} & c_1 & c_2 & c_3 & c_4 & c_5 & c_6 & c_7 & c_8 & c_9 \\ \begin{matrix} c_1 \\ c_2 \\ c_3 \\ c_4 \\ c_5 \\ c_6 \\ c_7 \\ c_8 \\ c_9 \end{matrix} & \begin{bmatrix} 0 & 1 & 0 & 1 & 0 & 0 & 0 & 1 & 0 \\ 0 & 0 & 0 & 1 & 1 & 0 & 0 & 0 & 0 \\ 1 & 0 & 0 & 0 & 0 & 1 & 0 & 0 & 1 \\ 0 & 0 & 0 & 0 & 1 & 1 & 0 & 0 & 0 \\ 0 & 0 & 0 & 0 & 0 & 0 & 0 & 0 & 0 \\ 0 & 0 & 0 & 0 & 1 & 0 & 1 & 0 & 1 \\ 0 & 0 & 1 & 0 & 0 & 1 & 0 & 0 & 0 \\ 0 & 0 & 0 & 0 & 0 & 0 & 0 & 0 & 1 \\ 0 & 1 & 0 & 1 & 1 & 0 & 1 & 0 & 0 \end{bmatrix} \end{matrix}.$$

Now we get the merged graph Z of the experts 1, 2, 3 and 5.

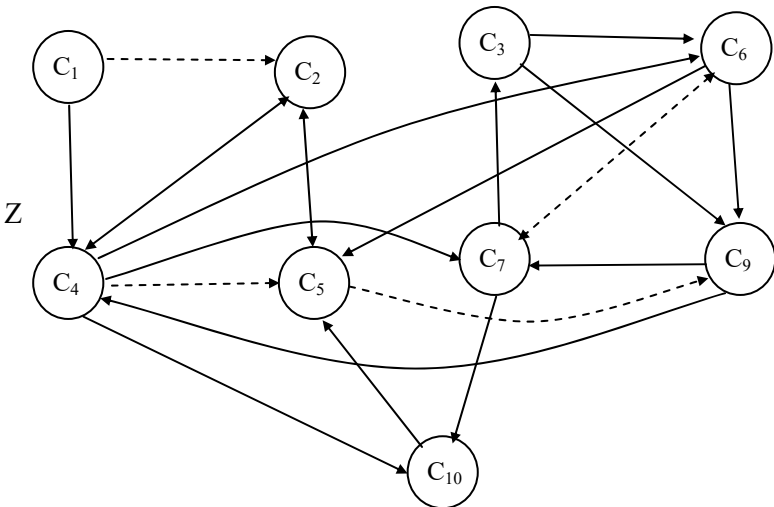

Let M_Z be the merged connection matrix of the merged graph Z .

$$M_Z = \begin{matrix} & c_1 & c_2 & c_3 & c_4 & c_5 & c_6 & c_7 & c_9 & c_{10} \\ \begin{matrix} c_1 \\ c_2 \\ c_3 \\ c_4 \\ c_5 \\ c_6 \\ c_7 \\ c_9 \\ c_{10} \end{matrix} & \begin{bmatrix} 0 & 1 & 0 & 1 & 0 & 0 & 0 & 0 & 0 \\ 0 & 0 & 0 & 1 & 1 & 0 & 0 & 0 & 0 \\ 0 & 0 & 0 & 0 & 0 & 1 & 0 & 0 & 0 \\ 0 & 1 & 0 & 0 & 1 & 0 & 1 & 0 & 1 \\ 0 & 1 & 0 & 0 & 0 & 0 & 0 & 1 & 0 \\ 0 & 0 & 0 & 0 & 1 & 0 & 1 & 1 & 0 \\ 0 & 0 & 1 & 0 & 0 & 1 & 0 & 0 & 1 \\ 0 & 0 & 0 & 1 & 0 & 0 & 1 & 0 & 0 \\ 0 & 0 & 0 & 0 & 1 & 0 & 0 & 0 & 0 \end{bmatrix} \end{matrix}.$$

Now we get the merged graph α of the four experts 2, 3, 4 and 5.

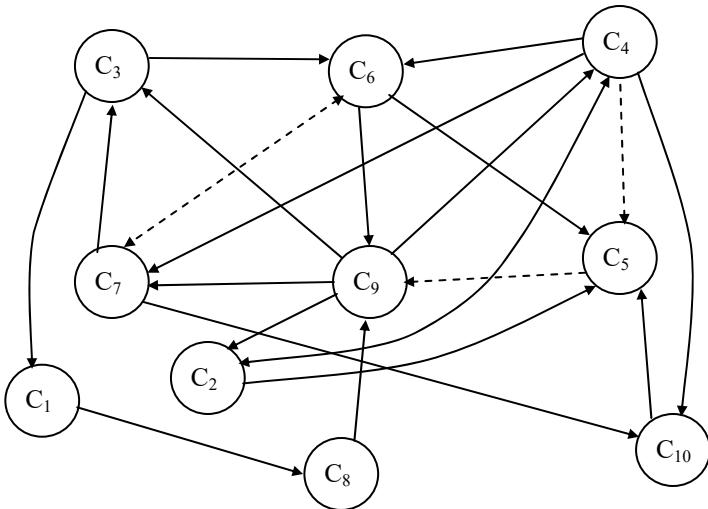

The connection merged matrix M_α of the merged graph α is as follows.

The matrix is a neutrosophic matrix with all the 10 concepts C_1, C_2, \dots, C_{10} .

$$M_\alpha = \begin{matrix} & \begin{matrix} c_1 & c_2 & c_3 & c_4 & c_5 & c_6 & c_7 & c_8 & c_9 & c_{10} \end{matrix} \\ \begin{matrix} c_1 \\ c_2 \\ c_3 \\ c_4 \\ c_5 \\ c_6 \\ c_7 \\ c_8 \\ c_9 \\ c_{10} \end{matrix} & \begin{bmatrix} 0 & 0 & 0 & 0 & 0 & 0 & 0 & 1 & 0 & 0 \\ 0 & 0 & 0 & 1 & 1 & 0 & 0 & 0 & 0 & 0 \\ 1 & 0 & 0 & 0 & 0 & 0 & 1 & 0 & 0 & 0 \\ 0 & 1 & 0 & 0 & I & 1 & 1 & 0 & 0 & 1 \\ 0 & 0 & 0 & 0 & 0 & 0 & 0 & 0 & I & 0 \\ 0 & 0 & 0 & 0 & 1 & 0 & I & 0 & 1 & 0 \\ 0 & 0 & 1 & 0 & 0 & I & 0 & 0 & 0 & 1 \\ 0 & 0 & 0 & 0 & 0 & 0 & 0 & 0 & 1 & 0 \\ 0 & 1 & 1 & 1 & 0 & 0 & 1 & 0 & 0 & 0 \\ 0 & 0 & 0 & 0 & 1 & 0 & 0 & 0 & 0 & 0 \end{bmatrix} \end{matrix} .$$

Now we give the merged directed graph β given by 1, 3, 4 and 5.

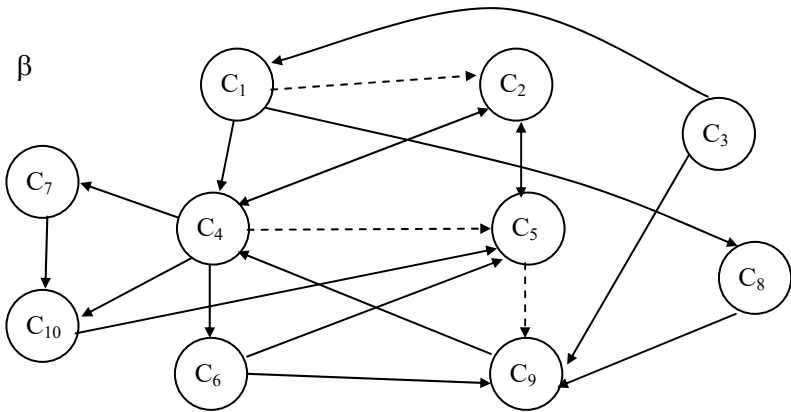

Let M_β denote the merged connection matrix of the merged graph β which is as follows:

$$M_\beta = \begin{matrix} & c_1 & c_2 & c_3 & c_4 & c_5 & c_6 & c_7 & c_8 & c_9 & c_{10} \\ \begin{matrix} c_1 \\ c_2 \\ c_3 \\ c_4 \\ c_5 \\ c_6 \\ c_7 \\ c_8 \\ c_9 \\ c_{10} \end{matrix} & \begin{bmatrix} 0 & 1 & 0 & 1 & 0 & 0 & 0 & 1 & 0 & 0 \\ 0 & 0 & 0 & 1 & 1 & 0 & 0 & 0 & 0 & 0 \\ 1 & 0 & 0 & 0 & 0 & 0 & 0 & 0 & 1 & 0 \\ 0 & 1 & 0 & 0 & 1 & 1 & 1 & 0 & 0 & 1 \\ 0 & 1 & 0 & 0 & 0 & 0 & 0 & 0 & 1 & 0 \\ 0 & 0 & 0 & 0 & 1 & 0 & 0 & 0 & 1 & 0 \\ 0 & 0 & 0 & 0 & 0 & 0 & 0 & 0 & 0 & 1 \\ 0 & 0 & 0 & 0 & 0 & 0 & 0 & 0 & 1 & 0 \\ 0 & 0 & 0 & 1 & 0 & 0 & 0 & 0 & 0 & 0 \\ 0 & 0 & 0 & 0 & 1 & 0 & 0 & 0 & 0 & 0 \end{bmatrix} \end{matrix} .$$

We see this gives the integrated merged NCMs of the problem.

It is important to note that even without the inclusion of all the experts a few of the experts can contribute to the integrated merged NCMs.

It may so happen that we may get some integrated merged NCMs leading to the complete problems. They may also be distinct.

So in this case we to overcome the problem of selecting which set of experts define a new NCMs model called the average NCMs model.

We can adopt the method new average NCMs model for these merged NCMs which is introduced in the last chapter of this book.

Further we have defined in chapter IV the notion of Kosko Hamming distance for NCMs and FCMs. We can use this distance to study how far two systems vary from each other and if the distance / deviation is small we accept the solution.

If on the other hand the deviation is large we investigate the cause for it. Thus by these methods applied to the merged models we can analyse the problem in a sensitive and in a productive way which will help. The experts draw appropriate conclusions.

We suggest a few problems for this chapter.

Problem:

1. Obtain some special features enjoyed by merged graphs.
2. Show merged FCMs are in general better than the combined FCMs.
3. Use merged FCMs to study some special real world problem.
4. Find the special features enjoyed by merged FCMs.
5. Give a real world problem illustration by using merged FCMs.
6. Describe with an example the merged NCMs.
7. Give an illustration in the real world problem the notion of the linked merged FCMs.
8. What are the advantages of using merged FCMs and linked merged FCMs?
9. Study question 8 for NCMs.

10. Describe with an example the notion of specially merged FCMs (NCMs).
11. Describe with an example the notion of mixed merged FCMs and NCMs.
12. Prove these new techniques of merged FCMs (NCMs) make the analysis more sensitive with a better solution.

Chapter Three

KOSKO - HAMMING DISTANCE IN FCMs AND NCMs

In this chapter authors for the first time introduce the new notion of Kosko - Hamming distance (K-H) distance in vectors related to FCMs and NCMs. However K-H distance is nothing but a Hamming distance defined for a special type of vectors $x, y \in V^n$ which enjoy same initial properties.

So K-H distance in general cannot be defined for any two arbitrary

$x, y \in V^n = \{(x_1, \dots, x_n) \mid x_i \in Z_2 = \{0, 1\}, 1 \leq i \leq n\}$, they are resultant state vectors related with a FCMs or a NCMs model. Such study is innovative and show how far two experts agree or defer over an issue.

Such study will help to get more information on the problem their by making the solution more closer to truth and feasibility.

As said at the out set Kosko-Hamming distance is a distance function depending on the NCMs or FCMs. So for one to define a K-H distance they basically need the resultants and properties of the FCMs (or NCMs).

Let $C = \{c_1, \dots, c_n\}$ be the n concepts / attributes related with the problem. Suppose some experts work with the same problem using all the n attributes using a FCM (or NCM) model.

However the researcher is interested in comparing the results of the t experts and wants to know how much they differ over the predicted results.

To this end we denote by the on state of the node C_1 alone by $X_1 = (1, 0, 0, 0, \dots, 0)$ the on state of the node C_2 by $X_2 = (0, 1, 0, \dots, 0)$ and so on and the on state of the node C_i by $X_i = (0, 0, \dots, 0, i, 0, \dots, 0)$ and finally the state on the node C_n by $X_n = (0, 0, \dots, 0, 1)$.

Let us denote the t experts by E_1, E_2, \dots, E_t . Let M_1 denote the connection matrix of the FCM (or NCM) which serves as the dynamical system of the first expert.

Let M_2 be the connection matrix associated with the directed graph given by the second expert. M_2 acts as the dynamical system of the FCMs for the second expert and so on.

Thus M_i denotes the connection matrix associated with the directed graph given by the i^{th} expert and M_i serves as the dynamical system of the FCMs for E_i the i^{th} expert. Finally M_t denotes the connection matrix associated with the directed graph given by the t^{th} expert E_t and M_t serves as the dynamical system of the FCMs.

Now to find Kosko Hamming distance denoted d_k we need the following conditions to be satisfied by the two vectors in $Z_2^n = \{(a_1, \dots, a_n) \mid a_i \in \{0, 1\}, 1 \leq i \leq n\}$ for which the Kosko - Hamming distance can be found.

(i) For any initial state vector $A = (a_1, \dots, a_n)$ we find using each of the t experts the hidden pattern by finding $AM_i, i = 1, 2, \dots, t$.

The resultant state vector that is the hidden pattern may be a fixed point or a limit cycle. Let $Y_1^A, Y_2^A, \dots, Y_t^A$ be the hidden patterns of the initial state vector A of the t experts. We can define the Kosko - Hamming distance only on the set of vectors $Y = (Y_1^A, Y_2^A, \dots, Y_t^A)$ clearly

$Y_i^A \in \{(a_1, a_2, \dots, a_n) \mid a_j \in \{0, 1\}, 1 \leq j \leq n\}$ and $i = 1, 2, \dots, t$.

$d_k(Y_r^A, Y_s^A) = \{\text{the Hamming distance between the vectors } Y_r^A \text{ and } Y_s^A \text{ in the set } Y\}$

$= d_k(E_r, E_s)$ because E_r is the r^{th} expert and E_s is the s^{th} expert and Y_r^A and Y_s^A are their the resultant vectors given by the experts on the initial state vector A .

Now clearly (1) $d_k(x, y) \geq 0$ or (2) $d_k(x, y) \leq n$.

If $d_k(E_r, E_s) = 0$ we say both the experts E_r and E_s agree on the outcome of the initial state vector A .

If $d_k(E_r, E_s) = m$ has a bigger value $0 \leq m \leq n$ we say the two experts do not agree over the outcome of the initial state vector A . So the experts have a different opinion hence this sort of comparison can make the study more sensitive and very closer to the solution or suggestions in

the investigation of the problem. In the final chapter of this book we have given about averages of the FCMs and NCMs and certainly this notion will be used there.

Now we will technically describe the working of the problem. Suppose we have n concepts or attributes related with the problem. We have say t experts E_1, E_2, \dots, E_t working with the problem using all the n concepts / attributes using either FCM or NCM. Suppose M_1, M_2, \dots, M_t are the t connection matrices given by the t experts respectively.

Let $X_1 = (1, 0, 0, \dots, 0), X_2 = (0, 1, 0, \dots, 0), X_3 = (0, 0, 1, \dots, 0)$ so on $X_n = (0, 0, \dots, 0, 1)$ be the initial state vectors with which we work.

X_1M_1 is calculated and the hidden pattern of X_1 is a fixed point or a limit cycle given by

$$Y_1^1 = \{(a_1, a_2, \dots, a_n) \mid a_i \in \{0, 1\}, 2 \leq i \leq n\}.$$

Let the hidden pattern for $X_2 = \{0, 1, 0, \dots, 0\}$ given by X_2M_1 be denoted by

$$Y_2^1 = \{(a_1, 1, a_3, \dots, a_n) \mid a_i \in \{0, 1\}, i \neq 2, i = 1, 3, \dots, n\}.$$

The hidden pattern for the initial state vector $X_3 = (0, 0, 1, 0, \dots, 0)$ is as follows.

The hidden pattern X_3M of the initial state vector X_3 be

$$Y_3^1 = \{(a_1, a_2, 1, a_4, \dots, a_n) \mid a_i \in \{0, 1\} \ i = 1, 2, 4, \dots, n\}.$$

Finally for $X_i = (0, 0, \dots, 0, i, 0, \dots, 0)$ the initial vector.

Let $X_i M_1$ give the resultant vector that is the hidden pattern of $X_i M_1$ as

$$Y_j^1 = \{(a_1 a_2, \dots, a_{i-1}, 1, a_{i+1} a_{i+2} \dots a_n) \mid a_j \in \{0, 1\}; j = 1, 2, \dots, i-1, i+1, \dots, n\} \text{ and so on.}$$

Finally for $X_n = (0, 0, \dots, 0, 1)$ we get $X_n M_1$'s resultant state vector of X_n 's to be

$$Y_n^1 = \{(a_1, \dots, a_{n-1}, 1) \mid a_i \in \{0, 1\} \text{ and } 1 \leq i \leq n-1\}.$$

On similar lines for each of the initial state vectors $X_1 = (1 0 0 \dots 0)$, $X_2 = (0 \dots 1 0)$ and so on $X_n = (0, \dots, 1, 0)$ we get using the dynamical system given by the second expert E_2 the hidden pattern to be $Y_1^2 = (1, a_2, \dots, a_n)$, $Y_2^2 = (a_1, 1, a_3, \dots, a_n)$ and so on.

$$Y_i^2 = (a_1, \dots, a_{i-1}, 1, a_{i+1}, \dots, a_n), \dots, \text{ and } Y_n^2 = (a_1 a_2 \dots a_{n-1}, 1)$$

Similarly for expert 3 and so on.

For expert i we get the resultant of X_1, \dots, X_n to be $Y_1^i = (1, a_2, \dots, a_n)$, $Y_2^i = (a_1 1, a_3, \dots, a_n)$ and so on. $Y_n^i = (a_1, a_2, \dots, a_{n-1}, 1)$ using the dynamical system M_i of the FCMs or NCMs.

Thus for the t^{th} expert E_t using the connection matrix M_t of the FCMs or NCMs we for the initial state vectors X_1, X_2, \dots, X_n get the resultant state vectors or hidden patterns to be $Y_1^t = (1, a_2, \dots, a_n)$, $Y_2^t = (a_1, 1, a_3, \dots, a_n)$ and so on $Y_n^t = (a_1, a_2, \dots, a_{n-1}, 1)$.

Now we give the sample representation of how the Kosko-Hamming distance is calculated this distance can be found provided at that time of comparison both the

experts work only on the same initial state vector otherwise the Kosko-Hamming distance cannot be found or it is meaningless. So if we compare the j th expert with a p th expert $1 \leq j, p \leq t$, we denote it by $d_k(Y_j^i, Y_p^i)$ and find that value.

That value can be found for $i = 1, 2, \dots, n$. So we can say for the i th initial state vector how close or how far the two experts j and p are in their predictions, however keeping in mind that the experts opinions show his ignorance or capabilities in tackling the problem and it also varies from expert to expert and problem to problem.

This is tabulated in the following form.

Hidden pattern of the initial state vectors given by the experts and K-H distance

Initial state vector	E_1	...	E_i	...	E_t	$d_k(E_1, E_2)$...	$d_k(E_{t-1}, E_t)$
X_1	Y_1^1	...	Y_1^i	...	Y_1^t	n_1^1	...	n_1^t
X_2	Y_2^1	...	Y_2^i	...	Y_2^t	n_2^1	...	n_2^t
\vdots	\vdots	...	\vdots	...	\vdots	\vdots	...	\vdots
X_n	Y_n^1	...	Y_n^i	...	Y_n^t	n_n^1	...	n_n^t

This table is called one initial on state vectors K–H distance comparison table.

Note that Y_j^i gives the resultant state vector of the initial state vector X_j for the i^{th} expert in the above table; $1 \leq i \leq t$ and $1 \leq j \leq n$.

However it is pertinent to keep on record that these initial vectors X_1, X_2, \dots, X_n are by no means given any form of even sample representations of the resultant by the resultant of the initial state vector X_1, \dots, X_n . That is we want to keep on record that if $X_1 + X_2 = (1\ 1\ 0\ 0 \dots 0) = X_{1,2}$ then

$$X_1 M_1 + X_2 M_1 \neq (X_1 + X_2) M_1$$

$\neq (Y_1^1 + Y_2^1)$ in general.

This is true for every $X_i, i = 1, 2, \dots, n$ and for every one of the connection matrices M_1, \dots, M_t , so we are forced to work with 2^n vectors with entries from n-vectors in $\{(a_1, a_2, \dots, a_n) \mid a_i \in \{0, 1\}, 1 \leq i \leq n\}$.

Now we can work with initial state vectors

$$\begin{aligned} X_{1,2} &= (1\ 1\ 0\ 0 \dots 0), \\ X_{1,3} &= (1\ 0\ 1\ 0 \dots 0), \\ X_{1,4} &= (1\ 0\ 0\ 1, 0 \dots 0) \text{ and} \\ &\text{so on } X_{1,n} = (1, 0, \dots, 0, 1). \end{aligned}$$

Likewise

$$\begin{aligned} X_{2,3} &= (0, 1, 1, 0, \dots, 0), \\ X_{2,4} &= (0, 1, 0, 1, 0, \dots, 0) \end{aligned}$$

and so on

$$X_{2,n} = (0, 1, 0, \dots, 0, 1).$$

$$\begin{aligned} X_{t,n} &= (0, \dots, 0, 1, 0, \dots, 1), \\ X_{t+1,n} &= (0, 0, \dots, 0, 1, 0, \dots, 1) \end{aligned}$$

and so on.

$$X_{n-1,n} = (0, 0, \dots, n-1, n).$$

We also work with three on state which gives ${}_nC_3$ number of such states.

Four number on state of nodes gives ${}_nC_4$ number of such initial state vectors and so on.

Finally we get ${}_nC_{n-1}$ number of such state vectors.

However we see if X_i has resultant Y_i and X_j has resultant Y_j then

$$X_iM + X_jM \neq Y_i + Y_j$$

because of this only we are forced to work in a different way to arrive at a solution.

We will illustrate this situation by an example.

Example 3.1: Let

$$M = \begin{bmatrix} 0 & 0 & 0 & 0 & 0 & 0 & 1 & 1 & -1 & 1 \\ 0 & 0 & 0 & 0 & 0 & 0 & 1 & 1 & 1 & 0 \\ 0 & 0 & 0 & 0 & 0 & 0 & -1 & -1 & -1 & -1 \\ 0 & 0 & 0 & 0 & 0 & 0 & -1 & -1 & -1 & 0 \\ 0 & 0 & 0 & 0 & 0 & 0 & 1 & -1 & 1 & 0 \\ 0 & 0 & 0 & 0 & 0 & 0 & -1 & -1 & -1 & -1 \\ 0 & 0 & 0 & 0 & 0 & 0 & 0 & 1 & 1 & 0 \\ 0 & 0 & 0 & 0 & 0 & 0 & 1 & 0 & 1 & 1 \\ 0 & 0 & 0 & 0 & 0 & 0 & 1 & 0 & 0 & -1 \\ 0 & 0 & 0 & 0 & 0 & 0 & 1 & 1 & -1 & 0 \end{bmatrix}$$

be a matrix associated with a problem involving 10 concepts c_1, c_2, \dots, c_{10} .

Let $X_1 = (1\ 0\ 0\ 0\ 0\ 0\ 0\ 0\ 0\ 0)$ be the given initial state vector where only the C_1 node is in the on state and all other nodes are in the off state.

We find $X_1M = (0\ 0\ 0\ 0\ 0\ 1\ 1\ -1\ 1)$ (after updating and thresholding we get Y_1) $\rightarrow Y_1 = (1\ 0\ 0\ 0\ 0\ 0\ 1\ 1\ 0\ 1)$ (\rightarrow denotes the vector has been updated and thresholded).

We find $Y_1M = (0\ 0\ 0\ 0\ 0\ 0\ 2\ 3\ 0\ 3) \rightarrow Y_2 = (1\ 0\ 0\ 0\ 0\ 0\ 1\ 1\ 0\ 1) = Y_1 \quad \dots\ I$

Thus the hidden pattern is a fixed point.

Next let us take $X_2 = (0\ 1\ 0\ 0\ 0\ 0\ 0\ 0\ 0\ 0)$ we see only the node C_2 is in the on state and all other nodes are in the off state. We find the resultant of the state vector X_2 on the dynamical system M.

$$X_2 M = (0\ 0\ 0\ 0\ 0\ 0\ 1\ 1\ 1\ 0) \rightarrow (0\ 1\ 0\ 0\ 0\ 0\ 1\ 1\ 1\ 0) = T_1 \text{ (say)}$$

$$T_2M \rightarrow (0\ 0\ 0\ 0\ 0\ 0\ 3\ 2\ 3\ 0) \rightarrow (0\ 1\ 0\ 0\ 0\ 0\ 1\ 1\ 1\ 0) = T_2 (= T_1) \quad \dots\ II$$

Using equations I and II we get

$$X_1 M + X_2M = Y_1 + T_1 = (1\ 0\ 0\ 0\ 0\ 0\ 1\ 1\ 0\ 1) + (0\ 1\ 0\ 0\ 0\ 0\ 1\ 1\ 1\ 0) = (1\ 1\ 0\ 0\ 0\ 0\ 0\ 1\ 1) \quad III$$

$$\text{Now consider } X_1 + X_2 = (1\ 0\ 0\ 0\ 0\ 0\ 0\ 0\ 0\ 0) + (0\ 1\ 0\ 0\ 0\ 0\ 0\ 0\ 0\ 0) = (1\ 1\ 0\ 0\ 0\ 0\ 0\ 0\ 0\ 0).$$

We find the effect of $X_1 + X_2$ on the dynamical system M.

$$\begin{aligned} (X_1 + X_2) M &= (0\ 0\ 0\ 0\ 0\ 0\ 2\ 2\ 0\ 1) \\ &\rightarrow (1\ 1\ 0\ 0\ 0\ 0\ 1\ 1\ 0\ 1) = S_1 \text{ (say)} \end{aligned}$$

$$\begin{aligned} S_1 M &= (0\ 0\ 0\ 0\ 0\ 0\ 4\ 3\ 0\ 3) \rightarrow (1\ 1\ 0\ 0\ 0\ 0\ 1\ 1\ 0\ 1) \\ &= S_2 (= S_1) \qquad \qquad \qquad \text{IV} \end{aligned}$$

Hence this is also a fixed point.

However III and IV are distinct so in general while working with FCM or NCM we see for the dynamical system M: $(X_1 + X_2) M \neq X_1 M + X_2 M$.

This forces us to find the Kosko-Hamming distance for every 2^n elements in the set $A = \{(a_1, \dots, a_n) \mid a_i \in \{0, 1\}, 1 \leq i \leq n\}$.

Hence we have to find d_k for two vectors in A provided they are resultant of the same basic initial state vector used by both experts but only the dynamical system used by them viz the connection matrices used by the concerned two experts are different.

Further we cannot as in case of vector spaces think if we work for the state vectors which forms a basis set we will get the resultant for other vectors. This is clearly proved in the example.

So it is not very difficult to write a program to find using the matrix which serves as the dynamical system for the FCM (or NCM) and find the appropriate Kosko-Hamming distance of the resultant state vectors which are the hidden patterns of the state vectors.

So for the Kosko-Hamming distance function we in the first place should have two distinct dynamical systems given by two different experts working on the same

problem with same number of nodes. Secondly for d_k to be defined at that time both experts should have worked only with the same initial state vector.

Only under these conditions we will be in a position to define d_k and compare them.

We will illustrate the situation by an example or two.

Example 3.2: Let E_1 and E_2 be any two experts working on the same problem with same number of nodes. Let them work with seven nodes c_1, c_2, \dots, c_7 .

Let G_1 be the directed graph given by the expert E_1 .

$G_1 =$

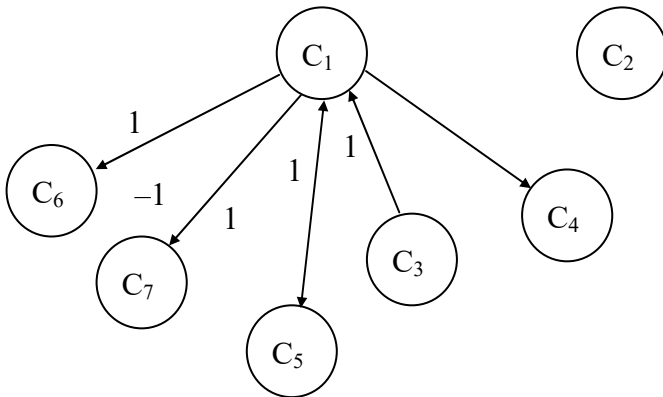

Let M_1 be the connection matrix associated with the graph G_1 which is as follows:

$$M_1 = \begin{matrix} & c_1 & c_2 & c_3 & c_4 & c_5 & c_6 & c_7 \\ \begin{matrix} c_1 \\ c_2 \\ c_3 \\ c_4 \\ c_5 \\ c_6 \\ c_7 \end{matrix} & \begin{bmatrix} 0 & 0 & 0 & 1 & 1 & 1 & -1 \\ 0 & 0 & 0 & 0 & 0 & 0 & 0 \\ 1 & 0 & 0 & 0 & 0 & 0 & 0 \\ 0 & 0 & 0 & 0 & 0 & 0 & 0 \\ 1 & 0 & 0 & 0 & 0 & 0 & 0 \\ 0 & 0 & 0 & 0 & 0 & 0 & 0 \\ 0 & 0 & 0 & 0 & 0 & 0 & 0 \end{bmatrix} \end{matrix} .$$

Let G_2 be the directed graph given by the second expert E_2 using the same set of concepts C_1, C_2, \dots, C_7 .

$G_2 =$

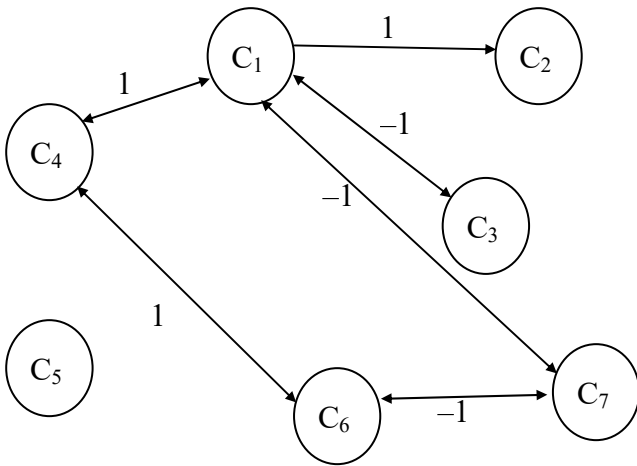

Let M_2 be the connection matrix associated with the graph G_2 which is as follows:

$$M_2 = \begin{matrix} & c_1 & c_2 & c_3 & c_4 & c_5 & c_6 & c_7 \\ \begin{matrix} c_1 \\ c_2 \\ c_3 \\ c_4 \\ c_5 \\ c_6 \\ c_7 \end{matrix} & \begin{bmatrix} 0 & 1 & -1 & 1 & 0 & 0 & -1 \\ 0 & 0 & 0 & 0 & 0 & 0 & 0 \\ -1 & 0 & 0 & 0 & 0 & 0 & 0 \\ 1 & 0 & 0 & 0 & 0 & 1 & 0 \\ 0 & 0 & 0 & 0 & 0 & 0 & 0 \\ 0 & 0 & 0 & 1 & 0 & 0 & -1 \\ -1 & 0 & 0 & 0 & 0 & -1 & 0 \end{bmatrix} \end{matrix}.$$

Now using these two matrices M_1 and M_2 of the FCM we work for the Kosko-Hamming distance between them.

Let $X_1 = (1\ 0\ 0\ 0\ 0\ 0\ 0)$ be the initial state vector. To find the effect of X_1 on the dynamical system M_1 and M_2 respectively.

$$X_1 M_1 = (0\ 0\ 0\ 1\ 1\ 1\ -1) \rightarrow (1\ 0\ 0\ 1\ 1\ 1\ 0) = Y_1$$

$$Y_1 M_1 = (2\ 0\ 0\ 1\ 1\ 1\ -1) \rightarrow (1\ 0\ 0\ 1\ 1\ 1\ 0) = Y_2 (= Y_1).$$

$$X_1 M_2 = (0\ 1\ -1\ 1\ 0\ 0\ -1) \rightarrow (1\ 1\ 0\ 1\ 0\ 0\ 0) = Z_1$$

$$Z_1 M_2 = (1\ 1\ -1\ 1\ 0\ 1\ -1) \rightarrow (1\ 1\ 0\ 1\ 0\ 1\ 0) = Z_2$$

$$Z_2 M_2 \rightarrow (1\ 1\ 0\ 1\ 0\ 1\ 0) = Z_3 (= Z_2).$$

$X_1 M_1$ gives the hidden pattern as $(1\ 0\ 0\ 1\ 1\ 1\ 0)$ and $X_1 M_2$ gives the hidden pattern as $(1\ 1\ 0\ 1\ 0\ 1\ 0)$.

We see $d_k((1\ 0\ 0\ 1\ 1\ 1\ 0)\ (1\ 1\ 0\ 1\ 0\ 1\ 0)) = 2$.

So from the Kosko-Hamming distance we see for the state vector $X_1 = (1\ 0\ 0\ 0\ 0\ 0\ 0)$ both the experts do agree or approximately close in their predictions.

Now let us consider the on state of the vector $S_1 = (0\ 0\ 0\ 1\ 0\ 0\ 0)$.

To find the effect of S_1 on M_1 and M_2 .

$$S_1M_1 = (1\ 0\ 0\ 0\ 0\ 0\ 0) \rightarrow (1\ 0\ 0\ 1\ 0\ 0\ 0) = (P_1 \text{ say})$$

$$P_1M_1 = (1\ 0\ 0\ 1\ 1\ 1\ -1) \rightarrow (1\ 0\ 0\ 1\ 1\ 1\ 0) = (P_2 \text{ say})$$

$$P_2M_1 = (2\ 0\ 0\ 1\ 1\ 1\ 0) \rightarrow (1\ 0\ 0\ 1\ 1\ 1\ 0) = P_3 (= P_2).$$

$$S_1M_2 = (1\ 0\ 0\ 0\ 0\ 1\ 0) \rightarrow (1\ 0\ 0\ 1\ 0\ 1\ 0) = R_1$$

$$R_1M_2 = (1\ 1\ -1\ 2\ 0\ 1\ -1) \rightarrow (1\ 1\ 0\ 1\ 0\ 1\ 0) = R_2$$

$$R_2M_2 = (1\ 1\ -1\ 2\ 0\ 1\ -2) \rightarrow (1\ 1\ 0\ 1\ 0\ 1\ 0) = R_3 (= P_2).$$

We find $d_k(E_1, E_2)$

$$= d_k((1\ 0\ 0\ 1\ 1\ 1\ 0), (1\ 1\ 0\ 1\ 0\ 1\ 0))$$

$$= 2.$$

Now we will find the Kosko - Hamming distance between the two experts opinion for the state vector $S_1 = (1\ 0\ 0\ 1\ 0\ 0\ 0)$. We find both S_1M_1 and S_1M_2 in the following.

Consider

$$S_1M_1 = (1\ 0\ 0\ 1\ 1\ 1\ -1) \rightarrow (1\ 0\ 0\ 1\ 1\ 1\ 0) = T_1$$

$$T_1M_1 = (1\ 0\ 0\ 1\ 1\ 1\ 0) = T_2 (=T_1) \quad \dots \text{ I}$$

$$S_1M_2 = (1\ 1\ -1\ 1\ 0\ 1\ -1) \rightarrow (1\ 1\ 0\ 1\ 0\ 1\ 0) = P_1 \text{ (say)}$$

$$P_1M_2 = (1\ 1\ -1\ 1\ 0\ 1\ -1) \rightarrow (1\ 1\ 0\ 1\ 0\ 1\ 0) = P_2$$

$$\text{Now } d_k((1\ 0\ 0\ 1\ 1\ 1\ 0), (1\ 1\ 0\ 1\ 0\ 1\ 0)) = 2.$$

We see the effect or resultant of the initial state vectors $(1\ 0\ 0\ 0\ 0\ 0\ 0)$, $(0\ 0\ 0\ 1\ 0\ 0\ 0)$ and $(1\ 0\ 0\ 1\ 0\ 0\ 0)$ using M_1 . The hidden pattern of all the three vectors are $(1\ 0\ 0\ 1\ 1\ 1\ 0)$, $(1\ 0\ 0\ 1\ 1\ 1\ 0)$ and $(1\ 0\ 0\ 1\ 1\ 1\ 0)$ respectively. That is the hidden pattern of all the three initial state vectors are the same in case of the dynamical system M_1 given by the first expert.

The hidden pattern associated with the initial state vector $(1\ 0\ 0\ 0\ 0\ 0\ 0)$, $(0\ 0\ 0\ 1\ 0\ 0\ 0)$ and $(1\ 0\ 0\ 1\ 0\ 0\ 0)$ using the M_2 are $(1\ 1\ 0\ 1\ 0\ 1\ 0)$, $(1\ 1\ 0\ 1\ 0\ 1\ 0)$, $(1\ 1\ 0\ 1\ 0\ 1\ 0)$ respectively. In case of the matrix M_2 or the second expert E_2 also we see the hidden patterns of the three vectors are the same.

Consider

$A_1 = (0\ 0\ 0\ 0\ 0\ 1\ 0)$ to be the initial state vector for which we wish to find the hidden pattern using M_1 .

$A_1M_1 = (0\ 0\ 0\ 0\ 0\ 0\ 0) \rightarrow (0\ 0\ 0\ 0\ 0\ 1\ 0)$ a fixed point with no change.

Now we find $A_1M_2 = (0\ 0\ 0\ 1\ 0\ 0\ -1) \rightarrow (0\ 0\ 0\ 1\ 0\ 1\ 0) = A_2$

$$A_2M_2 = (1\ 0\ 0\ 1\ 0\ 1\ 0) \rightarrow (1\ 0\ 0\ 1\ 0\ 1\ 0) = A_3$$

$$A_3M_2 = (1\ 1\ -1\ 2\ 0\ 1\ -1) \rightarrow (1\ 1\ 0\ 1\ 0\ 1\ 0) = A_4$$

$$A_4M_2 = (1\ 1\ -1\ 1\ 0\ 1\ -1) \rightarrow (1\ 1\ 0\ 1\ 0\ 1\ 0) = A_4$$

We see

$$d_k(E_1, E_2) = d_k((0\ 0\ 0\ 0\ 0\ 1\ 0), (1\ 1\ 0\ 1\ 0\ 1\ 0)) = 3.$$

Now we find the effect of $B_1 = (0\ 0\ 0\ 0\ 0\ 0\ 1)$ on the dynamical systems M_1 and M_2 .

$$B_1M_1 = (-1 \ 0 \ 0 \ 0 \ 0 \ 0) \rightarrow (0 \ 0 \ 0 \ 0 \ 0 \ 1) \text{ no change.}$$

Now $B_1M_2 = (-1 \ 0 \ 0 \ 0 \ 0 \ -1 \ 0) \rightarrow (0 \ 0 \ 0 \ 0 \ 0 \ 0 \ 1)$ no change. Thus $d_k(E_1, E_2) = d_k((0 \ 0 \ 0 \ 0 \ 0 \ 0 \ 1), (0 \ 0 \ 0 \ 0 \ 0 \ 0 \ 1)) = 0$.

That is the distance between these two resultant vectors is zero. That is for the initial state vector B_1 we see both the experts agree upon the effect that is why the Kosko-Hamming distance is zero.

Thus Kosko-Hamming distance measures how far two experts agree on the effect of a initial state vector or how much they disagree upon it.

Such type of study is new and for the first time authors study this as it would throw light on the deviations from one expert to another while analyzing the problem using FCMs or NCMs.

Let us now study the same situation for NCMs for the same problem by the experts E_3 and E_4 . Now let G_3 be the neutrosophic directed graph given by the expert E_3 .

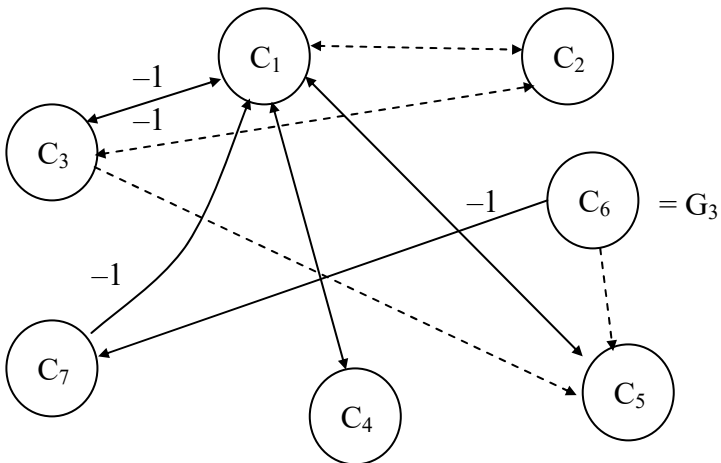

Let M_3 be the neutrosophic connection matrix associated with the neutrosophic directed graph which is as follows:

$$M_3 = \begin{matrix} & c_1 & c_2 & c_3 & c_4 & c_5 & c_6 & c_7 \\ \begin{matrix} c_1 \\ c_2 \\ c_3 \\ c_4 \\ c_5 \\ c_6 \\ c_7 \end{matrix} & \begin{bmatrix} 0 & I & -1 & 1 & 1 & 0 & 0 \\ I & 0 & I & 0 & 0 & 0 & 0 \\ -1 & I & 0 & 0 & I & 0 & 0 \\ 1 & 0 & 0 & 0 & 0 & 0 & 0 \\ 1 & 0 & 0 & 0 & 0 & 0 & 0 \\ 0 & 0 & 0 & 0 & I & 0 & -1 \\ -1 & 0 & 0 & 0 & 0 & 0 & 0 \end{bmatrix} \end{matrix} .$$

Let G_4 be the directed neutrosophic graph given by the forth expert on the same problem.

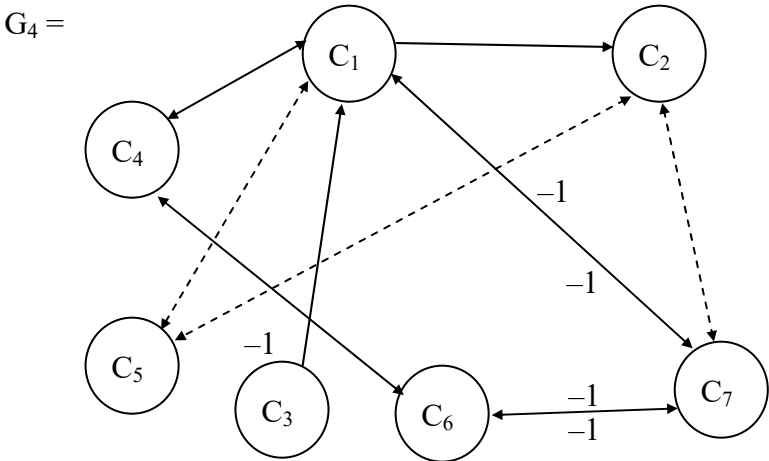

Let M_4 denote the neutrosophic connection matrix associated with the neutrosophic directed graph G_4 .

$$M_4 = \begin{matrix} & c_1 & c_2 & c_3 & c_4 & c_5 & c_6 & c_7 \\ \begin{matrix} c_1 \\ c_2 \\ c_3 \\ c_4 \\ c_5 \\ c_6 \\ c_7 \end{matrix} & \begin{bmatrix} 0 & 1 & 0 & 1 & I & 0 & -1 \\ 0 & 0 & 0 & 0 & I & 0 & I \\ -1 & 0 & 0 & 0 & 0 & 0 & 0 \\ 1 & 0 & 0 & 0 & 0 & 0 & 0 \\ I & I & 0 & 0 & 0 & 0 & 0 \\ 0 & 0 & 0 & 1 & 0 & 0 & -1 \\ -1 & I & 0 & 0 & 0 & -1 & 0 \end{bmatrix} \end{matrix}.$$

Now we will find the on state of the node C_1 alone. That is let $X_1 = (1\ 0\ 0\ 0\ 0\ 0\ 0)$. To find the effect of X_1 on M_3 and M_4 .

$$X_1M_3 = (0\ I\ -1\ 1\ 1\ 0\ 0) \rightarrow (1\ I\ 0\ 1\ 1\ 0\ 0) = Y_1 \text{ (say)}$$

$$Y_1M_3 = (0\ I\ -1\ 1\ 1\ 0\ 0) \rightarrow (1\ I\ 0\ 1\ 1\ 0\ 0) = Y_1 \text{ (say)}$$

$$Y_2M_3 = (1\ I\ -1\ +I\ 1\ 1+I\ 0\ 0) \rightarrow (1\ I\ I\ 1\ I\ 0\ 0) = Y_3 \text{ (say)}$$

$$Y_3M_3 = (1\ I\ I\ 1\ I\ 0\ 0) \rightarrow Y_4 (=Y_3 \text{ say}).$$

Thus the hidden pattern is a fixed point.

Now consider

$$X_1M_4 = (0\ 1\ 0\ 1\ I\ 0\ -1) \rightarrow (1\ 1\ 0\ 1\ I\ 0\ 0) = Z_1 \text{ say}$$

$$Z_1M_4 = (I, 1+I, 0, 1, I+I, 0, -1 + I) \rightarrow (1\ I\ 0\ 1\ I\ 0\ I) = Z_2 \text{ (say)}$$

$$Z_2M_4 = (1\ I\ 0\ 1\ I\ 0\ I) = Z_3 (=Z_2) \text{ say is a fixed point.}$$

Now we have not yet defined Kosko-Hamming distance or for that matter Hamming distance in case of

neutrosophic n -tuples of the form (a_1, a_2, \dots, a_n) where $a_i \in \{\langle Z_2 \cup I \rangle, \langle Z \cup I \rangle \text{ or } \langle R \cup I \rangle \text{ and so on}\}$ $1 \leq i \leq n$.

We define this now in the following.

Let $x = (x_1, \dots, x_n)$ and $y = (y_1, \dots, y_n) \in \{\langle Z_2 \cup I \rangle, \langle Z \cup I \rangle \text{ or } \langle Q \cup I \rangle \text{ or } \langle R \cup I \rangle\}$ we define the Hamming distance $d(x, y) = d((x_1, \dots, x_n), (y_1, \dots, y_n)) = t$ where t a positive integer denotes the number of places in which x differs from y , $0 \leq t \leq n$.

We will illustrate this situation.

Let $x = (I, 0, 1, I+1, I, 1, 0)$ and $y = (1, 0, I, 1 + I, I, I, 0)$ then the Hamming distance $d(x, y) = 3$. This is the way Hamming distance is defined.

Let $x = (1, 1, 1, 1, I, I, I, 0, 1 + I)$ and $y = (2, 3, 4, 1, I, 1+I, 3+5I, 7I, 8)$.

Now $d(x, y) = 7$. Thus the Hamming distance between x and y is 7 that is x differs from y in seven places.

Now to define Kosko-Hamming distance we need two state vectors associated with two NCMs working on same initial state vector over the same problem using the same number of concepts. This is a basic need for one to define the Kosko-Hamming distance for two resultant vectors. Such study helps one to compare how far two experts agree or disagree over the same nodes influence on their respective dynamical systems. Thus in this case from the example we see

$d_k(E_3, E_4) = d_k((1, I, I, 1, I, 0, 0), (1, I, 0, 1, I, 0, I)) = 2$, which shows they agree on majority of the nodes and disagree only on the two nodes.

Nothing prevents us from comparing the experts E_i and E_j where one of them work on the NCMs and other work using FCMs but both work on the same problem with same set of nodes.

We now find for the initial state vector $X_3 = (0 \ 0 \ 1 \ 0 \ 0 \ 0 \ 0)$ the effect of X_3 on M_3 and M_4 respectively.

$$X_3M_3 = (-1, I, 0, 0, I, 0, 0) \rightarrow (0, I, 1, 0, I, 0, 0) = Y_1 \text{ (say)}$$

$$Y_1M_3 = (2I-1, I, I, 0, I, 0, 0) \rightarrow (I, I, 1, 0, I, 0, 0) = Y_2 \text{ (say)}$$

$$Y_2M_3 = (2I-1, 2I, 0, I, I, 0, 0) \rightarrow (I, I, 1, I, I, 0, 0) = Y_3 \text{ (say)}$$

$$Y_3M_3 = (I, 2I, 0, I, I, 0, 0) \rightarrow (I, I, 1, I, I, 0, 0) = Y_4 \text{ (=Y}_3\text{) (say); clearly the hidden pattern is a fixed point.}$$

Now we find

$$X_3M_4 = (-1, 0, 1, 0, 0, 0, 0) \rightarrow (0 \ 0 \ 1 \ 0 \ 0 \ 0 \ 0) = X_3$$

So as far as X_3 on the dynamical system M_3 is concerned we see it is fixed point.

Now we find

$$d_k(E_3, E_4)$$

$$= d_k((I, I, 1, I, I, 0, 0), (0, 0, 1, 0, 0, 0, 0)) = 4.$$

Thus we see both the experts have different opinion as far as the node C_3 is concerned.

Consider the on state of the node $X_7 = (0\ 0\ 0\ 0\ 0\ 0\ 1)$ to find the effect of X_7 of the dynamical systems M_3 and M_4 .

$$X_1M_3 = (-1\ 0\ 0\ 0\ 0\ 0\ 1) \rightarrow (0\ 0\ 0\ 0\ 0\ 0\ 1)$$

is a fixed point.

$$X_7M_4 = (-1\ I\ 0\ 0\ 0\ -1\ 0) \rightarrow (0\ I\ 0\ 0\ 0\ 0\ 1) = P_1(\text{say})$$

$$P_1M_4 = (-1\ I\ 0\ 0\ I\ -1\ I) \rightarrow (0\ I\ 0\ 0\ I\ 0\ I) = P_2 \text{ say}$$

$$\begin{aligned} P_2M_4 &= (-1+I, 2I, 0, 0, I, -I, I) \\ &\rightarrow (I, I, 0, 0, I, 0, 1) \\ &= P_3 (\text{say}) \end{aligned}$$

$$\begin{aligned} P_3M_4 &= (I-1, 3I, 0, 0, I, 0, 0) \\ &\rightarrow (I, I, 0, 0, I, 0, 1) \\ &= P_4 (\text{say}) = P_3. \end{aligned}$$

Thus

$$d_k(E_3, E_4)$$

$$\begin{aligned} &= d_k((0, 0, 0, 0, 0, 0, 1), (I, I, 0, 0, I, 0, 1)) \\ &= 3. \end{aligned}$$

This is the way comparisons are performed between M_3 and M_4 .

We will tabulate in a table of the four experts two of them working using FCMs and two using NCMs on the same problem.

C_i	E_1	E_2	E_3
(1000000)	(1001110)	(1101010)	(1111100)
(0100000)	(0100000)	(0100000)	((1111100) or (1101100))
(0010000)	(0010000)	(0010000)	(1110100)
(0001000)	(1001110)	(1101010)	(1101100)
(0000100)	(1001110)	(0000100)	(1000100)
(0000010)	(1001110)	(1101010)	(1101110)
(0000001)	(0000001)	(0000001)	(0000001)
(1100000)	(1101110)	(1101010)	(1111100)
(1000100)	(1001110)	(1101010)	(1101100)
(0110010)	(1111110)	(1101010)	(1111100)
(1111000)	(1111110)	(1111010)	(1111100)

E_4	$d_k(E_1, E_2)$	$d_k(E_1, E_3)$	$d_k(E_1, E_4)$
(1101101)	2	3	5
(1101101)	0	4 or 3	4
(0010000)	0	3	0
(1101101)	2	1	4
(1100101)	3	2	3
(1101101)	2	2	4
(0100101)	0	0	2
(1101101)	1	2	3
(1101101)	2	2	3
(1111111)	2	3	2
(1111101)	1	2	3

$d_k(E_2, E_3)$	$d_k(E_2, E_4)$	$d_k(E_3, E_4)$
4	3	4
4 or 3	4	2
3	0	3
3	4	4
1	3	3
2	4	2
0	2	2
3	3	3
3	4	1
4	3	4
2	3	1

However one has to work with ${}^7C_1 + {}^7C_2 + {}^7C_3 + \dots + {}^7C_5 + {}^7C_6$ number of possible state vectors and find the relative 6 columns to compare them.

For the 11 initial vectors state vectors tabulated above we see experts one and two agree very rarely for the maximum Kosko-Hamming distance in 3. So also experts 1 and 3 agree in this manner. However experts E_1 and E_4 does not agree on the initial state vector (1 0 0 0 0 0).

Expert E_2 and E_3 , E_2 and E_4 , and E_3 and E_4 disagree on certain initial state vectors as the Kosko-Hamming distance is four.

So we can study and analyse these in a special way to arrive at a result. It is pertinent to define a norm for acceptance or rejection or reanalysis of a node. This is carried out in the following way.

Suppose (c_1, \dots, c_n) are the n concepts under study and E_1, E_2, \dots, E_t as the t experts working with it.

If $d_k(E_i, E_j) < \lfloor \frac{n}{2} \rfloor$ we do not re analyse.

If $d_k(E_i, E_j) \geq \lfloor \frac{n}{2} \rfloor$ we analyse them and see why the underlying node is giving a result of this form $1 \leq i, j \leq t$. A special mention about that node will be made in the study and conclusions of the problem.

Now this technique can be made for merged FCMs and merged NCMs also. For we take each experts opinion and when we have a common node we study the Kosko-Hamming distance between them.

Incase we get several integrated complete FCMs and NCMs we study the Kosko-Hamming distance between them.

Such study is illustrated here from the examples given in chapter II of this book. Consider the merged graphs of the four experts working with the concepts $\{C_1, C_2, \dots, C_{12}\}$.

We only use the graphs of the I, II, III and IV of the four experts.

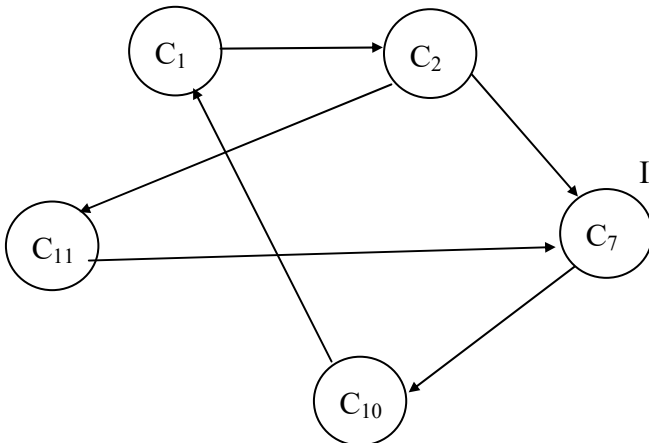

Let M_I be the directed graph given by the first expert.

The connection matrix associated with the graph I is as follows:

$$M_I = \begin{matrix} & c_1 & c_2 & c_7 & c_{10} & c_{11} \\ \begin{matrix} c_1 \\ c_2 \\ c_7 \\ c_{10} \\ c_{11} \end{matrix} & \begin{bmatrix} 0 & 1 & 0 & 0 & 0 \\ 0 & 0 & 1 & 0 & 1 \\ 0 & 0 & 0 & 1 & 0 \\ 1 & 0 & 0 & 0 & 0 \\ 0 & 0 & 1 & 0 & 0 \end{bmatrix} \end{matrix} .$$

Let the graph given by the second expert be denoted by II which is as follows:

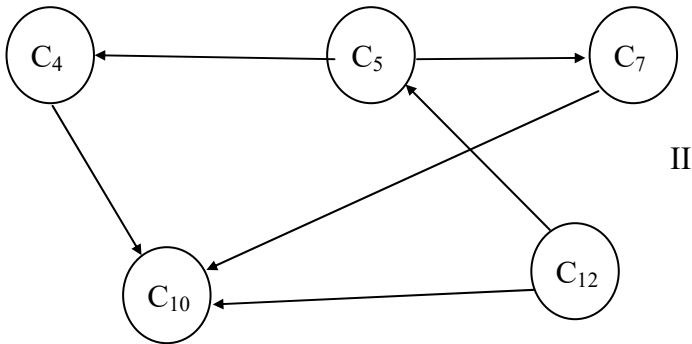

Using the second experts graph II we have the following connection matrix of the second expert.

$$M_{II} = \begin{matrix} & c_4 & c_5 & c_7 & c_{10} & c_{12} \\ c_4 & \left[\begin{array}{cccccc} 0 & 0 & 0 & 1 & 0 \\ 1 & 0 & 1 & 0 & 0 \\ 0 & 0 & 0 & 1 & 0 \\ 0 & 0 & 0 & 0 & 0 \\ 0 & 1 & 0 & 1 & 0 \end{array} \right] \end{matrix} .$$

Now we work with the on state of the node C_7 alone using M_I in the initial state vector and all other nodes are in the off state.

Consider $X_7 = (00100)$

$$\begin{aligned} X_7 M_I &= (00010) \rightarrow (00110) = Y_1 \text{ (say)} \\ Y_1 M_I &= (10010) \rightarrow (10110) = Y_2 \text{ (say)} \\ Y_2 M_I &= (11010) \rightarrow (11110) = Y_3 \text{ (say)} \\ Y_3 M_I &= (11111) = Y_4 \text{ (say)} \\ Y_4 M_I &\rightarrow (11111) = P_1. \end{aligned}$$

The hidden pattern is a fixed point given by P_1 .

Now we find

$$\begin{aligned} X_7 M_{II} &= (00010) \rightarrow (00110) = Y_1 \text{ (say)} \\ Y_1 M_{II} &= (00010) = Y_2 \text{ (say)} \\ &\rightarrow (00110) = Y_3 (=Y_1) = Q_1. \end{aligned}$$

Hence the fixed point is the hidden pattern given by Q_1 . Obvious we cannot find the Kosko-Hamming between the two experts.

So we expand the state vectors to the final form. Authors by the term expand mean the missing nodes in all

the 12 nodes will be put with zeros as the value. Now P_1 is expanded as P_1^c follows.

$$\begin{aligned}
 P_1 &= (c_1, c_2, c_7, c_{10}, c_{11}) \\
 &= (c_1, c_2, 0, 0, 0, 0, c_7, 0, 0, c_{10}, c_{11}, 0) \\
 P_1^c &= (1\ 1\ 0\ 0\ 0\ 0\ 1\ 0\ 0\ 1\ 1\ 0).
 \end{aligned}$$

Now Q_1 is also expanded as Q_1^c which is as follows:

$$\begin{aligned}
 Q_1 &= (c_4, c_5, c_7, c_{10}, c_{12}) \\
 Q_1^c &= (000c_4\ c_5\ 0\ c_7\ 0\ 0\ c_{10}\ 0\ c_{12}) \\
 &= (0\ 0\ 0\ 0\ 0\ 0\ 1\ 0\ 0\ 1\ 0\ 0) \\
 d_k(P_1^c, Q_1^c) &= 3.
 \end{aligned}$$

This is the way we find in case of several experts for which we wish to work with merged FCM or NCMs find the Kosko-Hamming distance for expanded resultant vectors.

It is pertinent to keep on record in this case not all the nodes are comparable we may have one or two which happens to be common are comparable.

Let us consider the experts II and IV the connection matrices given by them are

$$M_{II} = \begin{matrix} & c_4 & c_5 & c_7 & c_{10} & c_{12} \\ \begin{matrix} c_4 \\ c_5 \\ c_7 \\ c_{10} \\ c_{12} \end{matrix} & \begin{bmatrix} 0 & 0 & 0 & 1 & 0 \\ 1 & 0 & 1 & 0 & 0 \\ 0 & 0 & 0 & 1 & 0 \\ 0 & 0 & 0 & 0 & 0 \\ 0 & 1 & 0 & 1 & 0 \end{bmatrix} \end{matrix}$$

and

$$M_{IV} = \begin{matrix} & c_3 & c_6 & c_8 & c_9 & c_{10} & c_{12} \\ c_3 & \left[\begin{array}{cccccc} 0 & 1 & 0 & 1 & 0 & 0 \\ c_6 & 0 & 0 & 0 & 0 & 1 & 1 \\ c_8 & 0 & 0 & 0 & 1 & 0 & 0 \\ c_9 & 0 & 0 & 0 & 0 & 0 & 1 \\ c_{10} & 0 & 1 & 1 & 0 & 0 & 0 \\ c_{12} & 0 & 0 & 0 & 0 & 0 & 0 \end{array} \right] \end{matrix} .$$

The nodes c_{10} and c_{12} are common for both the experts II and IV. So we can find the resultant for the initial state vectors.

$A_1 = (00010)$, $A_2 = (00001)$ and $A_3 = (00011)$ in case of expert II and $B_1 = (000010)$, $B_2 = (000001)$ and $B_3 = (000011)$ in case of expert IV we calculate the resultant in the following.

$$\begin{aligned} A_1M_{II} &\rightarrow (00010) \\ A_2M_{II} &= (01010) \rightarrow (01011) = X_1 \text{ say} \\ X_1M_{II} &= (11110) \rightarrow (11111) = X_2 \text{ say} \\ X_2M_{II} &= (11111) = X_3 (=X_2). \end{aligned}$$

Now

$$\begin{aligned} A_3M_{II} &= (01010) \rightarrow (01011) = Y_1 \text{ say} \\ Y_1M_{II} &= (11110) \rightarrow (11111) = Y_2 \text{ (say)} \\ Y_2M_{II} &\rightarrow 3 (=Y_2). \end{aligned}$$

Thus we see in case of both A_2 and A_3 the hidden pattern of the dynamical system M_2 is a fixed point infact the same resultant (11111).

Now we find the hidden $B_1 = (000010)$ using M_{IV} which is as follows:

$$B_1 M_{IV} = (011000) \rightarrow (011010) = Z_1$$

$$Z_1 M_{IV} = (011011) = Z_2$$

$$Z_2 M_{IV} \rightarrow (011111) = Z_3 (=Z_2).$$

Thus the hidden pattern is a fixed point.

Now we expand the resultant vectors of the dynamical system M_{II} and M_{IV} .

$$X_2^c = (000110100101)$$

$$Y_2^c = (000110100101)$$

$$Z_2^c = (000001011101)$$

$$d_k(X_2^c, Z_2^c) = ((000110100101) (000001011101)) = 6.$$

The extended Kosko-Hamming distance is 6.

Now let $B_2 = (000001)$

$$B_2 M_{IV} \rightarrow (000001) = T_1.$$

$T_1^c = (000000000001)$ is the extended state vector of T_1

Now $d_k(Y_2^c, T_1^c)$

$$= ((000110100101) (000000000001))$$

= 4. Thus the extended Kosko-Hamming distance is 4.

Now we proceed on to use the Kosko-Hamming distance for two merged FCMs where the merging of different set of experts is carried out.

Consider the two dynamical system of the merged FCMs given by the merged connection matrices M_D and M_K given in chapter two of this book.

Let $\{C_1, C_2, \dots, C_{10}\}$ be the 10 attributes we find the 10 attributes we find the Kosko-Hamming distance using a

few of the initial state vectors. Let $d_k(M_D, M_k)$ denote the Kosko-Hamming distance is not on two experts but on their merged FCMs.

We tabulate as follows:

C_i	Hidden patterns given by M_K	Hidden pattern given by M_D	$d_k(M_D, M_K)$
(100...0)	(1110I1III0)	(1110III000)	3
(010...0)	(0110I1III0)	(011IIIIII)	3
(0010...0)	(0010IIIIII)	(0110IIIIII)	1
(00010...0)	(0II1IIIIII)	(00010IIIIII)	3
(000010...0)	(0110I111111)	(0000100000)	7
(0000010...0)	(0000010000)	(00000110I0)	2
(0000001000)	(0110I111111)	(0000011010)	5
(0000000100)	(0110I111111)	(000I0111I0)	5
(0000000010)	(0110I1II1I)	(000001010)	6
(0000000001)	(0110I1I0I1)	(000I000I11)	8
(1100...0)	(1110I1III0)	(1110III0I0)	2
(10010...0)	(1111I0I1111)	(110I1IIII1)	4
(1000110000)	(111111I1111)	(1100111I0)	5
(0100000001)	(0110I1111I)	(011I I I I I I I)	3
(0000110000)	(00I0I1111I)	(000011I010)	4
(0000001001)	(0110I11111)	(000I011I11)	6
(0000000110)	(0110I11111)	(000I011111)	4
(0000000101)	(01100I1111)	(000I011I11)	4
(1101101100)	(1110I11111)	(1111111111)	3
(0001110001)	(0110I1II11)	(000I011111)	7
(0000000111)	(0110I11111)	(000I011111)	5
(0000011110)	(0110I11111)	(000I011111)	3
(0011101110)	(0111111111)	(0111111111)	0

It is pertinent to mention that the about example is in no way connected with any of the problems. It is just

constructed for the example sake. Only this is an illustrate example.

Now one more quality of this notion is it can be used in finding the most influential / vital node. So the $d_k(c_i, c_j)$ can also predict the influential node describe in chapter III of this book.

Now finally we can also use this concept in New Average FCMs and New Average NCMs which will be developed in chapter V of this book. Thus this notion will also be used in finding the Kosko-Hamming distance between every expert and the average FCMs value given by all the experts.

If the Kosko-Hamming distance is small or negligible we need not find the hidden pattern for each of the experts but only FCM or New Average NCM which will save both time and economy.

Thus we will be using this concept in the last chapter of this book.

We suggest the few problems.

Problems:

1. Find some special features enjoyed by Kosko-Hamming distance on NCMs and FCMs.
2. Construct a real world problem model using FCMs with 10 experts, and use the concept of Kosko-Hamming distance on the experts opinion.

3. Study the same model using NCMs with same number of experts mentioned in problem 2.
4. Distinguish between Hamming distance and Kosko-Hamming distance.
5. Prove Kosko-Hamming distance aids in finding the influential nodes.
6. Illustrate problem 5 by some examples.
7. Construct a real world problem model and obtain the Kosko-Hamming distance table.
8. Develop any other property related with Hamming-Kosko distance.
9. Use Kosko-Hamming distance to study the merged FCMs model.
10. Use Kosko-Hamming distance to study the mixed merged FCMs and NCMs models.
11. Obtain some FCMs and NCMs models and use Kosko-Hamming distance to study a few properties associated with it.
12. Prove some interesting results on Kosko-Hamming distance for extended (expanded) hidden patterns.
13. Study the problem 12 on a real world model.
14. Using Kosko-Hamming distance predict a problem on two experts E_1 and E_2 who work with FCM and NCMs respectively.

Chapter Four

NEW AVERAGE FCMs AND NEW AVERAGE NCMs

In this chapter authors for the first time introduce two types of New Average FCMs and NCMs, one is a New Simple Average FCMs (NSAFCMs) and another is New Average FCMs. The analogue for NCMs is also carried out in this book. We make some simple assumptions before we define the new average FCMs and new average NCMs.

We redefine or rename the concepts in such a way that all these FCMs or NCMs take values from the set $\{0, 1\}$ or $\{0, 1, I\}$ respectively. Only such study will nullify the draw back of canceling of two opinions of the two expert if one is -1 and other is $+1$. So this is over come and we use this concept of new average FCMs and NCMs only under this basic assumption.

We now describe define and develop first the notion of Average Simple FCMs.

Let us suppose n experts work on a problem with the same set of attributes c_1, c_2, \dots, c_t .

All the n experts choose to work with FCMs using only these t attributes.

Let M_1, M_2, \dots, M_n be the n connection matrices where $M = \frac{1}{n} \sum_{i=1}^n M_i$ given by the n -experts who use only 0 or 1 as edge weights.

$$a_{ij} = \begin{cases} 1 & \text{if } a_{ij} = x \quad x \geq \left\lfloor \frac{n}{2} \right\rfloor \\ 0 & \text{if } a_{ij} = x \quad x < \left\lfloor \frac{n}{2} \right\rfloor \end{cases}$$

We see $M = (a_{ij}); a_{ij} \in \{0, 1\}; 1 \leq i, j \leq t$.

We call M the new average dynamical system of the new average simple FCM as the entries are 0 or 1.

This FCM associated with the connection matrix M is defined as the New Average Simple FCMs (NASFCMs).

Now instead of FCMs all the m experts work on the problem using NCMs with values from the set $\{0, 1, I\}$ using the same t attributes $\{c_1, c_2, \dots, c_t\}$ and if N_1, N_2, \dots, N_m are the neutrosophic matrices then we find

$$N = \frac{1}{m} \sum_{i=1}^m N_i = (a_{ij})$$

$$a_{ij} = \begin{cases} 1 & \text{if } a_{ij} = x + y \text{ and } x \geq \left\lfloor \frac{m}{2} \right\rfloor \text{ with } y < x \\ I & \text{if } a_{ij} = x + y \text{ and } y \geq \left\lfloor \frac{m}{2} \right\rfloor \text{ with } x < y \\ 0 & \text{if } a_{ij} = x + y \text{ and } x < \left\lfloor \frac{m}{2} \right\rfloor \text{ with } y < \left\lfloor \frac{m}{2} \right\rfloor \\ a + bI & \text{if } a_{ij} = x + y \text{ and } x \geq \left\lfloor \frac{m}{2} \right\rfloor \text{ and } y \geq \left\lfloor \frac{m}{2} \right\rfloor \end{cases}$$

Now $N = (a_{ij})$ is called the New Simple Average dynamical system of the new simple average neutrosophic matrices N_1, N_2, \dots, N_m .

Now we can also use the mixed new average simple FCM and NCM whose dynamical system is defined as follows:

$$\begin{aligned} \text{Let } T &= \frac{(N + M)}{2} \\ &= \left(\frac{n_{ij} + m_{ij}}{2} \right) \end{aligned}$$

where

$$t_{ij} = \begin{cases} 1 & \text{if } \frac{n_{ij} + m_{ij}}{2} \geq 0.5 \\ 0 & \text{if } \frac{n_{ij} + m_{ij}}{2} < 0.5 \\ I & \text{if } \frac{n_{ij} + m_{ij}}{2} \geq 0.5I \text{ (neutrosophic part)} \\ 1 + I & \text{if both neutrosophic part and real part is } \geq 0.5 \\ & (1 \leq i, j \leq t) \end{cases}$$

Now T has the values from the set {0, 1, I} so T is associated with the New Average simple mixed FCMs and NCMs.

We will first illustrate this by an example before we proceed onto define New Average FCMs, New Average NCMs and New average mixed FCMs and NCMs.

However we keep on record, this example is just an illustration and is not a resultant of working with any real world problem.

Example 4.1: Let us consider some 6 attributes {c₁, c₂, c₃, c₄, c₅, c₆} related to one problem. Four experts agree to work with the problem using FCMs.

All of them agree to work on these 6 attributes using the weights of the graphs to be either 0 or 1 only.

Let G₁ be the directed graph given by the first expert on the problem.

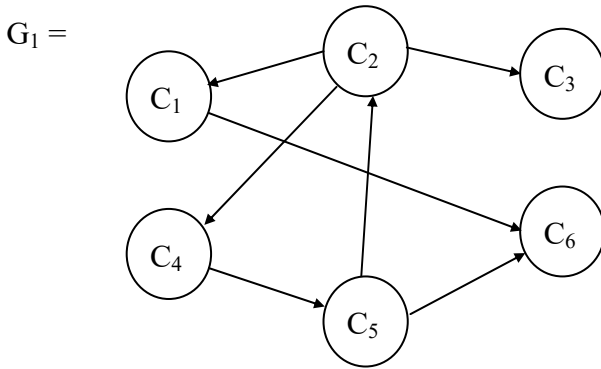

Let M_1 be the connection matrix associated with the direct graph G_1 which is as follows:

$$M_1 = \begin{matrix} & \begin{matrix} c_1 & c_2 & c_3 & c_4 & c_5 & c_6 \end{matrix} \\ \begin{matrix} c_1 \\ c_2 \\ c_3 \\ c_4 \\ c_5 \\ c_6 \end{matrix} & \begin{bmatrix} 0 & 0 & 0 & 0 & 0 & 1 \\ 1 & 0 & 1 & 1 & 0 & 0 \\ 0 & 0 & 0 & 0 & 0 & 0 \\ 0 & 0 & 0 & 0 & 1 & 0 \\ 0 & 1 & 0 & 0 & 0 & 1 \\ 0 & 0 & 0 & 0 & 0 & 0 \end{bmatrix} \end{matrix} .$$

Let G_2 be the directed graph given by the second expert using the nodes c_1, c_2, \dots, c_6 .

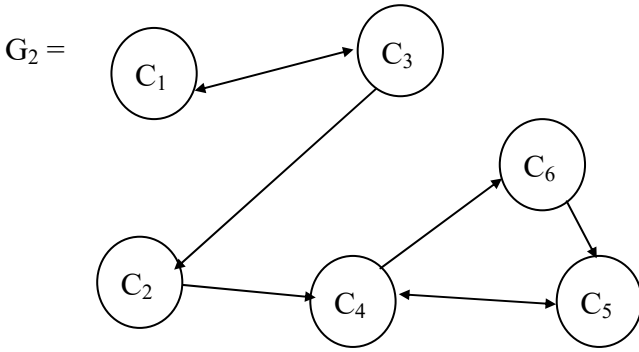

The connection matrix of the graph G_2 be M_2 which is as follows:

$$M_2 = \begin{matrix} & c_1 & c_2 & c_3 & c_4 & c_5 & c_6 \\ \begin{matrix} c_1 \\ c_2 \\ c_3 \\ c_4 \\ c_5 \\ c_6 \end{matrix} & \begin{bmatrix} 0 & 0 & 1 & 0 & 0 & 0 \\ 0 & 0 & 0 & 1 & 0 & 0 \\ 1 & 1 & 0 & 0 & 0 & 0 \\ 0 & 0 & 0 & 0 & 1 & 1 \\ 0 & 0 & 0 & 1 & 0 & 0 \\ 0 & 0 & 0 & 0 & 1 & 0 \end{bmatrix} \end{matrix} .$$

Let G_3 be the directed graph given by the third expert which is as follows:

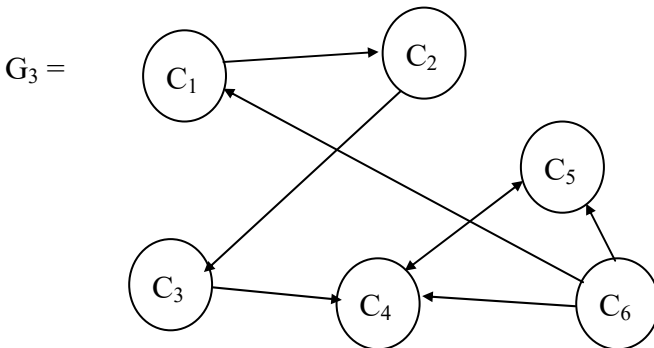

Let M_3 be the connection matrix associated with the graph G_3 which is as follows:

$$M_3 = \begin{matrix} & c_1 & c_2 & c_3 & c_4 & c_5 & c_6 \\ \begin{matrix} c_1 \\ c_2 \\ c_3 \\ c_4 \\ c_5 \\ c_6 \end{matrix} & \begin{bmatrix} 0 & 1 & 0 & 0 & 0 & 0 \\ 0 & 0 & 1 & 0 & 0 & 0 \\ 0 & 0 & 0 & 1 & 0 & 0 \\ 0 & 0 & 0 & 0 & 1 & 0 \\ 0 & 0 & 0 & 1 & 0 & 0 \\ 1 & 0 & 0 & 1 & 1 & 0 \end{bmatrix} \end{matrix} .$$

Let G_4 be the directed graph

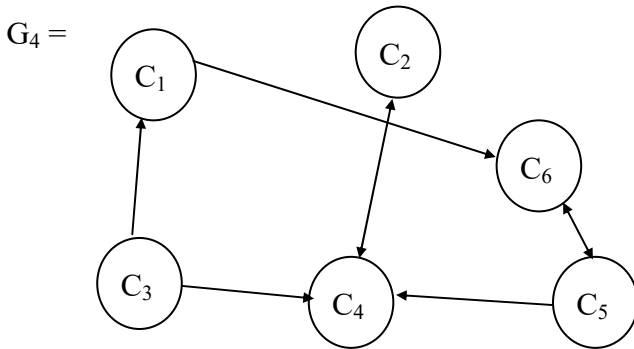

Let M_4 be the connection matrix related with G_4 which is as follows:

$$M_4 = \begin{matrix} & c_1 & c_2 & c_3 & c_4 & c_5 & c_6 \\ \begin{matrix} c_1 \\ c_2 \\ c_3 \\ c_4 \\ c_5 \\ c_6 \end{matrix} & \begin{bmatrix} 0 & 0 & 0 & 0 & 0 & 1 \\ 0 & 0 & 0 & 1 & 0 & 0 \\ 1 & 0 & 0 & 1 & 0 & 0 \\ 0 & 1 & 0 & 0 & 0 & 0 \\ 0 & 0 & 0 & 1 & 0 & 1 \\ 0 & 0 & 0 & 0 & 1 & 0 \end{bmatrix} \end{matrix} .$$

Now we find the average of the FCMs which is defined as the new simple defined as the New Simple Average FCMs (NSAFCMs) by finding

$$\frac{1}{4} (M_1 + M_2 + M_3 + M_4)$$

$$= \frac{1}{4} \begin{bmatrix} 0 & 1 & 1 & 0 & 0 & 2 \\ 1 & 0 & 2 & 3 & 0 & 0 \\ 2 & 1 & 0 & 2 & 0 & 0 \\ 0 & 1 & 0 & 0 & 3 & 1 \\ 0 & 0 & 0 & 3 & 0 & 2 \\ 1 & 0 & 0 & 1 & 3 & 0 \end{bmatrix}$$

$$= \begin{bmatrix} 0 & 0.25 & 0.25 & 0 & 0 & 0.5 \\ 0.25 & 0 & 0.5 & 0.75 & 0 & 0 \\ 0.5 & 0.25 & 0 & 0.5 & 0 & 0 \\ 0 & 0.25 & 0 & 0 & 0.75 & 0.25 \\ 0 & 0 & 0 & 0.75 & 0 & 0.5 \\ 0.25 & 0 & 0 & 0.25 & 0.75 & 0 \end{bmatrix} = (m_{ij}).$$

We see if $m_{ij} \geq 0.25$ put 1

if $m_{ij} < 0.25$ put 0.

$$\text{We see } M = \begin{matrix} & c_1 & c_2 & c_3 & c_4 & c_5 & c_6 \\ \begin{matrix} c_1 \\ c_2 \\ c_3 \\ c_4 \\ c_5 \\ c_6 \end{matrix} & \begin{bmatrix} 0 & 1 & 1 & 0 & 0 & 1 \\ 1 & 0 & 1 & 1 & 0 & 0 \\ 1 & 1 & 0 & 1 & 0 & 0 \\ 0 & 1 & 0 & 0 & 1 & 1 \\ 0 & 0 & 0 & 1 & 0 & 1 \\ 1 & 0 & 0 & 1 & 1 & 0 \end{bmatrix} \end{matrix} .$$

M is defined as the new average simple dynamical system associated with the new average simple FCMs.

We work with a few attributes in the on state using all the 5 dynamical systems in the following.

Let us now work with the dynamical system given by the first expert with the following initial state vectors.

$$X_1 = (1 \ 0 \ 0 \ 0 \ 0 \ 0)$$

$$X_2 = (0 \ 1 \ 0 \ 0 \ 0 \ 0)$$

$$X_3 = (0 \ 0 \ 1 \ 0 \ 0 \ 0)$$

$$X_4 = (0 \ 0 \ 0 \ 1 \ 0 \ 0)$$

$$X_5 = (0 \ 0 \ 0 \ 0 \ 1 \ 0)$$

$$X_6 = (0 \ 0 \ 0 \ 0 \ 0 \ 1)$$

$$X_{1,2} = (1 \ 1 \ 0 \ 0 \ 0 \ 0)$$

$$X_{3,6} = (0\ 0\ 1\ 0\ 0\ 1)$$

$$X_{4,5} = (0\ 0\ 0\ 1\ 1\ 0)$$

$$X_{1,3,5} = (1\ 0\ 1\ 0\ 1\ 0)$$

$$X_{2,4,6} = (0\ 1\ 0\ 1\ 0\ 1).$$

We will be working only with these 11 initial state vectors in case of all the experts as well as M the dynamical system of NASFCMs.

Let table 1 denote the initial set of state vectors in the first column and the second column the hidden pattern using the dynamical system M_1 .

Table 1

$X_1 = (1\ 0\ 0\ 0\ 0\ 0)$	$(1\ 0\ 0\ 0\ 0\ 1)$
$X_2 = (0\ 1\ 0\ 0\ 0\ 0)$	$(1\ 1\ 1\ 1\ 1\ 1)$
$X_3 = (0\ 0\ 1\ 0\ 0\ 0)$	$(0\ 0\ 1\ 0\ 0\ 0)$
$X_4 = (0\ 0\ 0\ 1\ 0\ 0)$	$(1\ 1\ 1\ 1\ 1\ 1)$
$X_5 = (0\ 0\ 0\ 0\ 1\ 0)$	$(1\ 1\ 1\ 1\ 1\ 1)$
$X_6 = (0\ 0\ 0\ 0\ 0\ 1)$	$(0\ 0\ 0\ 0\ 0\ 1)$
$X_{1,2} = (1\ 1\ 0\ 0\ 0\ 0)$	$(1\ 1\ 1\ 1\ 1\ 1)$
$X_{3,6} = (0\ 0\ 1\ 0\ 0\ 1)$	$(0\ 0\ 1\ 0\ 0\ 1)$
$X_{4,5} = (0\ 0\ 0\ 1\ 1\ 0)$	$(1\ 1\ 1\ 1\ 1\ 1)$
$X_{1,3,5} = (1\ 0\ 1\ 0\ 1\ 0)$	$(1\ 1\ 1\ 1\ 1\ 1)$
$X_{2,4,6} = (0\ 1\ 0\ 1\ 0\ 1)$	$(1\ 1\ 1\ 1\ 1\ 1)$

Now we work with same set of initial vectors and obtain the hidden pattern using M_2 which is given in table 2 in the following.

Table 2

$X_1 = (1\ 0\ 0\ 0\ 0\ 0)$	$(1\ 1\ 1\ 1\ 1\ 1)$
$X_2 = (0\ 1\ 0\ 0\ 0\ 0)$	$(0\ 1\ 0\ 1\ 1\ 1)$
$X_3 = (0\ 0\ 1\ 0\ 0\ 0)$	$(1\ 1\ 1\ 1\ 1\ 1)$
$X_4 = (0\ 0\ 0\ 1\ 0\ 0)$	$(0\ 0\ 0\ 1\ 1\ 1)$
$X_5 = (0\ 0\ 0\ 0\ 1\ 0)$	$(0\ 0\ 0\ 1\ 1\ 1)$
$X_6 = (0\ 0\ 0\ 0\ 0\ 1)$	$(0\ 0\ 0\ 1\ 1\ 1)$
$X_{1,2} = (1\ 1\ 0\ 0\ 0\ 0)$	$(1\ 1\ 1\ 1\ 1\ 1)$
$X_{3,6} = (0\ 0\ 1\ 0\ 0\ 1)$	$(1\ 1\ 1\ 1\ 1\ 1)$
$X_{4,5} = (0\ 0\ 0\ 1\ 1\ 0)$	$(0\ 0\ 0\ 1\ 1\ 1)$
$X_{1,3,5} = (1\ 0\ 1\ 0\ 1\ 0)$	$(1\ 1\ 1\ 1\ 1\ 1)$
$X_{2,4,6} = (0\ 1\ 0\ 1\ 0\ 1)$	$(0\ 1\ 0\ 1\ 1\ 1)$

Now using the dynamical system M_3 given by the 3rd expert we use the 11 initial values $X_1, X_2, \dots, X_{1,3,5}$ and $X_{2,4,6}$, find the hidden pattern and tabulate in table 3 in the following.

Table 3

$X_1 = (1\ 0\ 0\ 0\ 0\ 0)$	$(1\ 1\ 1\ 1\ 1\ 0)$
$X_2 = (0\ 1\ 0\ 0\ 0\ 0)$	$(0\ 1\ 1\ 1\ 1\ 0)$
$X_3 = (0\ 0\ 1\ 0\ 0\ 0)$	$(0\ 0\ 1\ 1\ 1\ 0)$
$X_4 = (0\ 0\ 0\ 1\ 0\ 0)$	$(0\ 0\ 0\ 1\ 1\ 0)$
$X_5 = (0\ 0\ 0\ 0\ 1\ 0)$	$(0\ 0\ 0\ 1\ 1\ 0)$
$X_6 = (0\ 0\ 0\ 0\ 0\ 1)$	$(1\ 1\ 1\ 1\ 1\ 1)$
$X_{1,2} = (1\ 1\ 0\ 0\ 0\ 0)$	$(1\ 1\ 1\ 1\ 1\ 0)$
$X_{3,6} = (0\ 0\ 1\ 0\ 0\ 1)$	$(1\ 1\ 1\ 1\ 1\ 1)$
$X_{4,5} = (0\ 0\ 0\ 1\ 1\ 0)$	$(0\ 0\ 0\ 1\ 1\ 0)$
$X_{1,3,5} = (1\ 0\ 1\ 0\ 1\ 0)$	$(1\ 1\ 1\ 1\ 1\ 0)$
$X_{2,4,6} = (0\ 1\ 0\ 1\ 0\ 1)$	$(1\ 1\ 1\ 1\ 1\ 1)$

Now we use the dynamical system given by the fourth expert M_4 and find the hidden pattern for all the 11 initial

state vectors and tabulate in the table 4 which is as follows.

Table 4

$X_1 = (1\ 0\ 0\ 0\ 0\ 0)$	$(1\ 1\ 0\ 1\ 1\ 1)$
$X_2 = (0\ 1\ 0\ 0\ 0\ 0)$	$(0\ 1\ 0\ 1\ 0\ 0)$
$X_3 = (0\ 0\ 1\ 0\ 0\ 0)$	$(1\ 1\ 1\ 1\ 1\ 1)$
$X_4 = (0\ 0\ 0\ 1\ 0\ 0)$	$(0\ 1\ 0\ 1\ 0\ 0)$
$X_5 = (0\ 0\ 0\ 0\ 1\ 0)$	$(1\ 1\ 1\ 1\ 1\ 1)$
$X_6 = (0\ 0\ 0\ 0\ 0\ 1)$	$(0\ 1\ 0\ 1\ 1\ 1)$
$X_{1,2} = (1\ 1\ 0\ 0\ 0\ 0)$	$(1\ 1\ 0\ 1\ 1\ 1)$
$X_{3,6} = (0\ 0\ 1\ 0\ 0\ 1)$	$(1\ 1\ 1\ 1\ 1\ 1)$
$X_{4,5} = (0\ 0\ 0\ 1\ 1\ 0)$	$(0\ 1\ 0\ 1\ 1\ 1)$
$X_{1,3,5} = (1\ 0\ 1\ 0\ 1\ 0)$	$(1\ 1\ 1\ 1\ 1\ 1)$
$X_{2,4,6} = (0\ 1\ 0\ 1\ 0\ 1)$	$(0\ 1\ 0\ 1\ 1\ 1)$

Now we find the hidden pattern using the new average simple FCM for the 11 initial state vectors and give them in the following table 5.

Table 5

$X_1 = (1\ 0\ 0\ 0\ 0\ 0)$	$(1\ 1\ 1\ 1\ 1\ 1)$
$X_2 = (0\ 1\ 0\ 0\ 0\ 0)$	$(1\ 1\ 1\ 1\ 1\ 1)$
$X_3 = (0\ 0\ 1\ 0\ 0\ 0)$	$(1\ 1\ 1\ 1\ 1\ 1)$
$X_4 = (0\ 0\ 0\ 1\ 0\ 0)$	$(1\ 1\ 1\ 1\ 1\ 1)$
$X_5 = (0\ 0\ 0\ 0\ 1\ 0)$	$(1\ 1\ 1\ 1\ 1\ 1)$
$X_6 = (0\ 0\ 0\ 0\ 0\ 1)$	$(1\ 1\ 1\ 1\ 1\ 1)$
$X_{1,2} = (1\ 1\ 0\ 0\ 0\ 0)$	$(1\ 1\ 1\ 1\ 1\ 1)$
$X_{3,6} = (0\ 0\ 1\ 0\ 0\ 1)$	$(1\ 1\ 1\ 1\ 1\ 1)$
$X_{4,5} = (0\ 0\ 0\ 1\ 1\ 0)$	$(1\ 1\ 1\ 1\ 1\ 1)$
$X_{1,3,5} = (1\ 0\ 1\ 0\ 1\ 0)$	$(1\ 1\ 1\ 1\ 1\ 1)$
$X_{2,4,6} = (0\ 1\ 0\ 1\ 0\ 1)$	$(1\ 1\ 1\ 1\ 1\ 1)$

From the table 5 we see the thresholding value 0.25 ought to be changed.

So now we in the average matrix put $m_{ij} = 1$ if $m_{ij} \geq 0.5$ and $m_{ij} = 0$ if $m_{ij} < 0.5$.

So the modified M is denoted by M' .

$$M' = \begin{matrix} & c_1 & c_2 & c_3 & c_4 & c_5 & c_6 \\ \begin{matrix} c_1 \\ c_2 \\ c_3 \\ c_4 \\ c_5 \\ c_6 \end{matrix} & \begin{bmatrix} 0 & 0 & 0 & 0 & 0 & 1 \\ 0 & 0 & 1 & 1 & 0 & 0 \\ 1 & 0 & 0 & 0 & 0 & 0 \\ 0 & 0 & 0 & 0 & 1 & 0 \\ 0 & 0 & 0 & 1 & 0 & 1 \\ 0 & 0 & 0 & 0 & 1 & 0 \end{bmatrix} \end{matrix}.$$

Now using this M' we find the hidden pattern of the 11 initial state vectors and tabulate them in the following table 6 which is as follows:

Table 6

$X_1 = (1\ 0\ 0\ 0\ 0\ 0)$	$(1\ 0\ 0\ 1\ 1\ 1)$
$X_2 = (0\ 1\ 0\ 0\ 0\ 0)$	$(1\ 1\ 1\ 1\ 1\ 1)$
$X_3 = (0\ 0\ 1\ 0\ 0\ 0)$	$(1\ 0\ 1\ 1\ 1\ 1)$
$X_4 = (0\ 0\ 0\ 1\ 0\ 0)$	$(0\ 0\ 0\ 1\ 1\ 1)$
$X_5 = (0\ 0\ 0\ 0\ 1\ 0)$	$(0\ 0\ 0\ 1\ 1\ 1)$
$X_6 = (0\ 0\ 0\ 0\ 0\ 1)$	$(0\ 0\ 0\ 1\ 1\ 1)$
$X_{1,2} = (1\ 1\ 0\ 0\ 0\ 0)$	$(1\ 1\ 1\ 1\ 1\ 1)$
$X_{3,6} = (0\ 0\ 1\ 0\ 0\ 1)$	$(1\ 0\ 1\ 1\ 1\ 1)$
$X_{4,5} = (0\ 0\ 0\ 1\ 1\ 0)$	$(0\ 0\ 0\ 1\ 1\ 1)$
$X_{1,3,5} = (1\ 0\ 1\ 0\ 1\ 0)$	$(1\ 0\ 1\ 1\ 1\ 1)$
$X_{2,4,6} = (0\ 1\ 0\ 1\ 0\ 1)$	$(1\ 1\ 1\ 1\ 1\ 1)$

Now we use the concept of Kosko-Hamming distance to study the closeness or distance of each of the experts in the predictions. We write under the columns $d_k(E_i, E_j)$ the Kosko-Hamming distance of the 11 hidden patterns of the experts E_i and E_j , $1 \leq i, j \leq 4$ (E_i, A) means the Kosko-Hamming distance between the 11 hidden patterns of the expert E_i and the NASFCMs, $1 \leq i \leq 4$.

This is given in the following table 7. However table 5 is not useful as the hidden pattern of all the 11 initial state vectors is (1 1 1 1 1 1).

Table 7

	$d_k(E_1, E_2)$	$d_k(E_1, E_3)$	$d_k(E_1, E_4)$	$d_k(E_1, A)$
$X_1 = (1\ 0\ 0\ 0\ 0\ 0)$	4	4	3	2
$X_2 = (0\ 1\ 0\ 0\ 0\ 0)$	2	2	4	0
$X_3 = (0\ 0\ 1\ 0\ 0\ 0)$	5	2	5	4
$X_4 = (0\ 0\ 0\ 1\ 0\ 0)$	3	4	4	3
$X_5 = (0\ 0\ 0\ 0\ 1\ 0)$	3	4	0	3
$X_6 = (0\ 0\ 0\ 0\ 0\ 1)$	2	5	3	2
$X_{1,2} = (1\ 1\ 0\ 0\ 0\ 0)$	0	1	1	0
$X_{3,6} = (0\ 0\ 1\ 0\ 0\ 1)$	4	4	4	3
$X_{4,5} = (0\ 0\ 0\ 1\ 1\ 0)$	3	4	2	3
$X_{1,3,5} = (1\ 0\ 1\ 0\ 1\ 0)$	0	1	0	1
$X_{2,4,6} = (0\ 1\ 0\ 1\ 0\ 1)$	2	0	2	0

$d_k(E_2, E_3)$	$d_k(E_2, E_4)$	$d_k(E_2, A)$	$d_k(E_3, E_4)$	$d_k(E_3, A)$	$d_k(E_4, A)$
1	1	2	2	3	1
2	2	2	2	2	4
3	0	1	3	2	1
1	3	0	3	1	3
1	3	0	4	1	3
3	1	0	2	3	1
1	1	0	2	1	1
0	0	1	0	1	1
1	1	0	2	1	1
1	0	1	1	2	1
2	0	2	2	0	2

We see from the table 7 the deviation of each of the experts from the average A is very less. Now we find \bar{A} the average of all the four experts for all the 11 hidden pattern and compare it A in the following table.

Table 8

X_i	\bar{A}	A	$d_k(A, \bar{A})$
$X_1 = (1\ 0\ 0\ 0\ 0\ 0)$	(1 1 1 1 1 1)	(1 0 0 1 1 1)	2
$X_2 = (0\ 1\ 0\ 0\ 0\ 0)$	(0 1 1 1 1 1)	(1 1 1 1 1 1)	1
$X_3 = (0\ 0\ 1\ 0\ 0\ 0)$	(1 1 1 1 1 1)	(1 0 1 1 1 1)	1
$X_4 = (0\ 0\ 0\ 1\ 0\ 0)$	(0 1 0 1 1 1)	(0 0 0 1 1 1)	1
$X_5 = (0\ 0\ 0\ 0\ 1\ 0)$	(1 1 1 1 1 1)	(0 0 0 1 1 1)	3
$X_6 = (0\ 0\ 0\ 0\ 0\ 1)$	(0 1 0 1 1 1)	(0 0 0 1 1 1)	1
$X_{1,2} = (1\ 1\ 0\ 0\ 0\ 0)$	(1 1 1 1 1 1)	(1 1 1 1 1 1)	0
$X_{3,6} = (0\ 0\ 1\ 0\ 0\ 1)$	(1 1 1 1 1 1)	(1 0 1 1 1 1)	1
$X_{4,5} = (0\ 0\ 0\ 1\ 1\ 0)$	(0 1 0 1 1 1)	(0 0 0 1 1 1)	1
$X_{1,3,5} = (1\ 0\ 1\ 0\ 1\ 0)$	(1 1 1 1 1 1)	(1 0 1 1 1 1)	1
$X_{2,4,6} = (0\ 1\ 0\ 1\ 0\ 1)$	(1 1 1 1 1 1)	(1 1 1 1 1 1)	0

We see except for the initial state vector X_5 all the deviations or 0, 1 and only one two. Thus there is not much of deviation as per the Kosko-Hamming distance between the hidden patterns of the average \bar{A} and that of the hidden pattern got from the NASFCMs.

Thus we by using NASFCMs can save time and economy. Now in the following table we give the value of $d_k(E_1, \bar{A})$, $d_k(E_2, \bar{A})$, $d_k(E_3, \bar{A})$ and $d_k(E_4, \bar{A})$ in the following.

Table 9

	$d_k(E_1, \bar{A})$	$d_k(E_2, \bar{A})$	$d_k(E_3, \bar{A})$	$d_k(E_4, \bar{A})$
$X_1 = (1\ 0\ 0\ 0\ 0\ 0)$	4	0	1	1
$X_2 = (0\ 1\ 0\ 0\ 0\ 0)$	1	1	1	3
$X_3 = (0\ 0\ 1\ 0\ 0\ 0)$	5	1	3	0
$X_4 = (0\ 0\ 0\ 1\ 0\ 0)$	2	0	2	2
$X_5 = (0\ 0\ 0\ 0\ 1\ 0)$	0	0	4	0
$X_6 = (0\ 0\ 0\ 0\ 0\ 1)$	3	0	2	0
$X_{1,2} = (1\ 1\ 0\ 0\ 0\ 0)$	0	0	1	1

$X_{3,6} = (0\ 0\ 1\ 0\ 0\ 1)$	4	1	0	0
$X_{4,5} = (0\ 0\ 0\ 1\ 1\ 0)$	2	0	2	0
$X_{1,3,5} = (1\ 0\ 1\ 0\ 1\ 0)$	3	1	1	0
$X_{2,4,6} = (0\ 1\ 0\ 1\ 0\ 1)$	3	2	0	2

Except for the first expert as in case of $d_k(E,A)$ we see the deviation is not very high.

Thus we have defined NASFCMs and shown using the new technique of Kosko-Hamming distance we see the deviations are considerably small so we have no problem of using NASFCMs instead of working with several experts. This gives equal importance to each and every expert. Further this saves time and economy so this new model will serve as a better one.

Next we proceed onto define the notion of New Average Simple NCMs. We assume NCMs take values only from the set $\{0, 1, I\}$.

Suppose we have n experts who wish to work only with the NCMs, then to find the New Average Simple NCMs (NASNCMs).

Let $\{c_1, c_2, \dots, c_t\}$ be the t -concepts associated with the problem and m -experts work with the problem using only the NCMs model. To find the new average simple NCMs. Let N_1, N_2, \dots, N_m be the m -connection neutrosophic matrices given by the m -experts.

$$\text{Let } N = \frac{1}{m} \sum_{i=1}^m N_i$$

$$= (n_{ij}) \text{ we see if } n_{ij} \geq \lfloor \frac{m}{2} \rfloor ;$$

$$\text{then put } n_{ij} = 1 \text{ (} n_{ij} \text{ real)}$$

if $n_{ij} = t + sI$ where t, s are real then

$$\text{put } n_{ij} = 1 \text{ if } t \geq s$$

$$= I \text{ if } t < s$$

if n_{ij} is real and $n_{ij} < \lfloor \frac{m}{2} \rfloor$ put 0.

Thus N takes values from the set $\{0, 1, I\}$.

Using N we can find the hidden pattern and N is defined as the New Average Simple dynamical NCM system.

We will illustrate this situation by an example.

Example 4.2: Let $C = \{C_1, C_2, C_3, C_4, C_5\}$ be the five attributes associated with the problem.

Let E_1, E_2 and E_3 be the three experts who work with the problem using the NCMs model and using the five attributes.

Let G_1 be the neutrosophic graph given by the first expert which is as follows.

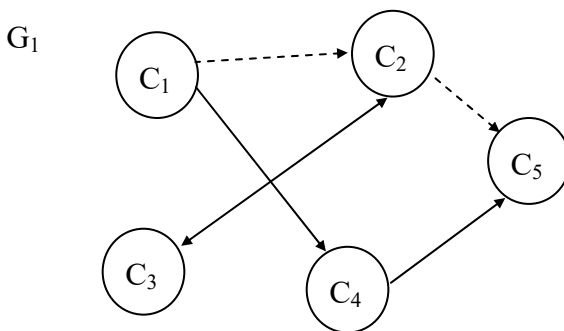

Let N_1 be the neutrosophic connection matrix associated with the neutrosophic graph G_1

$$N_1 = \begin{matrix} & c_1 & c_2 & c_3 & c_4 & c_5 \\ \begin{matrix} c_1 \\ c_2 \\ c_3 \\ c_4 \\ c_5 \end{matrix} & \begin{bmatrix} 0 & I & 0 & 1 & 0 \\ 0 & 0 & 1 & 0 & I \\ 0 & 1 & 0 & 0 & 0 \\ 0 & 0 & 0 & 0 & 1 \\ 0 & 0 & 0 & 0 & 0 \end{bmatrix} \end{matrix}.$$

Let G_2 be the neutrosophic directed graph associated with the NCM given by the second expert which is as follows:

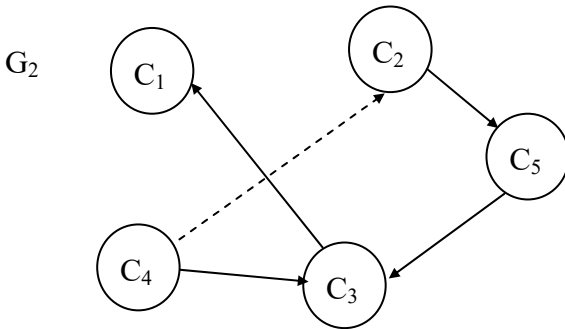

Let N_2 be the connection matrix associated with neutrosophic directed graph G_2 ;

$$N_2 = \begin{matrix} & c_1 & c_2 & c_3 & c_4 & c_5 \\ \begin{matrix} c_1 \\ c_2 \\ c_3 \\ c_4 \\ c_5 \end{matrix} & \begin{bmatrix} 0 & 0 & 0 & 0 & 0 \\ 0 & 0 & 0 & 0 & 1 \\ 1 & 0 & 0 & 0 & 0 \\ 0 & I & 1 & 0 & 0 \\ 0 & 0 & 1 & 0 & 0 \end{bmatrix} \end{matrix}.$$

Let G_3 be the graph associated with third expert E_3 which is as follows:

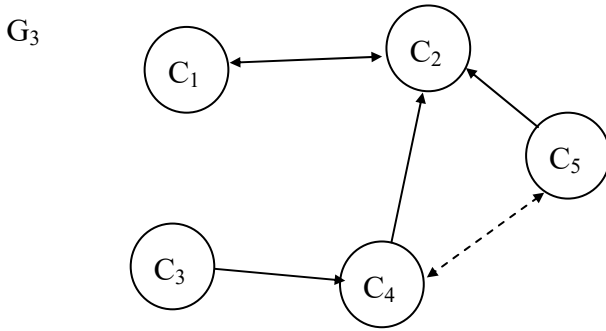

The neutrosophic connection matrix associated with the graph G_3 is as follows:

$$N_3 = \begin{matrix} & c_1 & c_2 & c_3 & c_4 & c_5 \\ \begin{matrix} c_1 \\ c_2 \\ c_3 \\ c_4 \\ c_5 \end{matrix} & \begin{bmatrix} 0 & 1 & 0 & 0 & 0 \\ 1 & 0 & 0 & 0 & 0 \\ 0 & 0 & 0 & 1 & 0 \\ 0 & 1 & 0 & 0 & I \\ 0 & 1 & 0 & I & 0 \end{bmatrix} & \cdot \end{matrix}$$

Let us find the hidden pattern of 12 initial state vectors and tabulate them in the following for the NCM given by the expert E_1 .

Table 1

Initial state vectors	Hidden pattern
$X_1 = (1\ 0\ 0\ 0\ 0)$	$(1\ I\ I\ I\ I)$
$X_2 = (0\ 1\ 0\ 0\ 0)$	$(0\ 1\ 1\ 0\ I)$
$X_3 = (0\ 0\ 1\ 0\ 0)$	$(0\ 1\ 1\ 0\ I)$

$X_4 = (0\ 0\ 0\ 1\ 0)$	$(0\ 0\ 0\ 1\ 1)$
$X_5 = (0\ 0\ 0\ 0\ 1)$	$(0\ 0\ 0\ 0\ 1)$
$X_{1,2} = (1\ 1\ 0\ 0\ 0)$	$(1\ 1\ 1\ 1\ 1)$
$X_{1,3} = (1\ 0\ 1\ 0\ 0)$	$(1\ 1\ 1\ 1\ 1)$
$X_{1,4} = (1\ 0\ 0\ 1\ 0)$	$(1\ 1\ 1\ 1\ 1)$
$X_{1,5} = (1\ 0\ 0\ 0\ 1)$	$(1\ 1\ 1\ 1\ 1)$
$X_{4,5} = (0\ 0\ 0\ 1\ 1)$	$(0\ 0\ 0\ 1\ 1)$
$X_{3,4} = (0\ 0\ 1\ 1\ 0)$	$(0\ 1\ 1\ 1\ 1)$
$X_{2,4} = (0\ 1\ 0\ 1\ 0)$	$(0\ 1\ 1\ 1\ 1)$

Now in table 2 we give for the 12 initial state vectors the hidden pattern given by the second expert using the dynamical system N_2 which is as follows:

Table 2

Initial state vectors	Hidden pattern
$X_1 = (1\ 0\ 0\ 0\ 0)$	$(1\ 0\ 0\ 0\ 0)$
$X_2 = (0\ 1\ 0\ 0\ 0)$	$(1\ 1\ 1\ 0\ 1)$
$X_3 = (0\ 0\ 1\ 0\ 0)$	$(1\ 0\ 1\ 0\ 1)$
$X_4 = (0\ 0\ 0\ 1\ 0)$	$(1\ 1\ 1\ 1\ 1)$
$X_5 = (0\ 0\ 0\ 0\ 1)$	$(1\ 0\ 1\ 0\ 1)$
$X_{1,2} = (1\ 1\ 0\ 0\ 0)$	$(1\ 1\ 1\ 0\ 1)$
$X_{1,3} = (1\ 0\ 1\ 0\ 0)$	$(1\ 0\ 1\ 0\ 1)$
$X_{1,4} = (1\ 0\ 0\ 1\ 0)$	$(1\ 1\ 1\ 1\ 1)$
$X_{1,5} = (1\ 0\ 0\ 0\ 1)$	$(1\ 0\ 0\ 0\ 1)$
$X_{4,5} = (0\ 0\ 0\ 1\ 1)$	$(1\ 1\ 1\ 1\ 1)$
$X_{3,4} = (0\ 0\ 1\ 1\ 0)$	$(1\ 1\ 1\ 1\ 1)$
$X_{2,4} = (0\ 1\ 0\ 1\ 0)$	$(1\ 1\ 1\ 0\ 1)$

We now find the 3rd expert opinion the neutrosophic matrix N_3 and tabulate the hidden pattern of the 12 initial state vectors in the following table 3.

Table 3

Initial state vectors	Hidden pattern
$X_1 = (1\ 0\ 0\ 0\ 0)$	$(1\ 1\ 0\ 0\ 0)$
$X_2 = (0\ 1\ 0\ 0\ 0)$	$(1\ 1\ 0\ 0\ 0)$
$X_3 = (0\ 0\ 1\ 0\ 0)$	$(1\ 1\ 1\ 1\ I)$
$X_4 = (0\ 0\ 0\ 1\ 0)$	$(1\ 1\ 0\ 1\ I)$
$X_5 = (0\ 0\ 0\ 0\ 1)$	$(1\ 1\ 0\ I\ 1)$
$X_{1,2} = (1\ 1\ 0\ 0\ 0)$	$(1\ 1\ 0\ 0\ 0)$
$X_{1,3} = (1\ 0\ 1\ 0\ 0)$	$(1\ 1\ 1\ 1\ I)$
$X_{1,4} = (1\ 0\ 0\ 1\ 0)$	$(1\ 1\ 0\ 1\ I)$
$X_{1,5} = (1\ 0\ 0\ 0\ 1)$	$(1\ 1\ 0\ I\ 1)$
$X_{4,5} = (0\ 0\ 0\ 1\ 1)$	$(1\ 1\ 0\ 1\ I)$
$X_{34} = (0\ 0\ 1\ 1\ 0)$	$(I\ 1\ 1\ 1\ I)$
$X_{2,4} = (0\ 1\ 0\ 1\ 0)$	$(0\ 1\ 0\ 1\ I)$

Next we find the average of the three NCMs N_1, N_2, N_3 .

$$N = \frac{1}{3}(N_1 + N_2 + N_3)$$

$$= \begin{bmatrix} 0 & 1+I & 0 & 0.33 & 0 \\ 0.33 & 0 & 0.66 & 0 & I \\ 0 & 0.33 & 0 & 0.33 & 0.33 \\ 0 & 1+I & 0 & 0 & 1+I \\ 0.33 & 0.33 & 0 & I & 0 \end{bmatrix} .$$

We after thresholding put 1 if $\alpha \geq 0.33$

I if $\alpha = I$

0 if $\alpha < 0.33$ finally 1 if $\alpha = 1 + I$.

$$N = \begin{bmatrix} 0 & 1 & 0 & 1 & 0 \\ 1 & 0 & 1 & 0 & 1 \\ 0 & 1 & 0 & 1 & 1 \\ 0 & 1 & 0 & 0 & 1 \\ 0 & 0 & 0 & 1 & 0 \end{bmatrix}.$$

Now N is known as the New Average Simple NCMs dynamical system.

Now we find the hidden pattern of all the 12 initial state vectors and tabulate them in table 4 in the following.

Table 4

Initial state vectors	Hidden pattern
$X_1 = (1\ 0\ 0\ 0\ 0)$	(1 1 1 1 1)
$X_2 = (0\ 1\ 0\ 0\ 0)$	(1 1 1 1 1)
$X_3 = (0\ 0\ 1\ 0\ 0)$	(1 1 1 1 1)
$X_4 = (0\ 0\ 0\ 1\ 0)$	(1 1 1 1 1)
$X_5 = (0\ 0\ 0\ 0\ 1)$	(1 1 1 1 1)
$X_{1,2} = (1\ 1\ 0\ 0\ 0)$	(1 1 1 1 1)
$X_{1,3} = (1\ 0\ 1\ 0\ 0)$	(1 1 1 1 1)
$X_{1,4} = (1\ 0\ 0\ 1\ 0)$	(1 1 1 1 1)
$X_{1,5} = (1\ 0\ 0\ 0\ 1)$	(1 1 1 1 1)
$X_{4,5} = (0\ 0\ 0\ 1\ 1)$	(1 1 1 1 1)
$X_{34} = (0\ 0\ 1\ 1\ 0)$	(1 1 1 1 1)
$X_{2,4} = (0\ 1\ 0\ 1\ 0)$	(1 1 1 1 1)

From the hidden pattern we see all the nodes come to on state for every initial vector. This is not any form of good prediction.

So review of the results forces us to change the thresholding function from 1 if $\alpha \geq 0.33$ to “1 if $\alpha \geq 0.5$.”

Now we redo the matrix N and denote it by N' which is as follows:

$$N' = \begin{matrix} & c_1 & c_2 & c_3 & c_4 & c_5 \\ \begin{matrix} c_1 \\ c_2 \\ c_3 \\ c_4 \\ c_5 \end{matrix} & \begin{bmatrix} 0 & 1 & 0 & 0 & 0 \\ 0 & 0 & 1 & 0 & 1 \\ 0 & 0 & 0 & 0 & 0 \\ 0 & 1 & 0 & 0 & 1 \\ 0 & 0 & 0 & 1 & 0 \end{bmatrix} \end{matrix}.$$

Now we find the hidden pattern for all the 12 initial vectors.

Table 5

Initial state vectors	Hidden pattern
$X_1 = (1\ 0\ 0\ 0\ 0)$	$(1\ 1\ 1\ 1\ 1)$
$X_2 = (0\ 1\ 0\ 0\ 0)$	$(0\ 1\ 1\ 1\ 1)$
$X_3 = (0\ 0\ 1\ 0\ 0)$	$(0\ 0\ 1\ 0\ 0)$
$X_4 = (0\ 0\ 0\ 1\ 0)$	$(0\ 1\ 1\ 1\ 1)$
$X_5 = (0\ 0\ 0\ 0\ 1)$	$(0\ 1\ 1\ 1\ 1)$
$X_{1,2} = (1\ 1\ 0\ 0\ 0)$	$(1\ 1\ 1\ 1\ 1)$
$X_{1,3} = (1\ 0\ 1\ 0\ 0)$	$(1\ 1\ 1\ 1\ 1)$
$X_{1,4} = (1\ 0\ 0\ 1\ 0)$	$(1\ 1\ 1\ 1\ 1)$
$X_{1,5} = (1\ 0\ 0\ 0\ 1)$	$(1\ 1\ 1\ 1\ 1)$
$X_{4,5} = (0\ 0\ 0\ 1\ 1)$	$(0\ 1\ 1\ 1\ 1)$
$X_{34} = (0\ 0\ 1\ 1\ 0)$	$(0\ 1\ 1\ 1\ 1)$
$X_{2,4} = (0\ 1\ 0\ 1\ 0)$	$(0\ 1\ 1\ 1\ 1)$

Now we will use the Kosko-Hamming distance defined in chapter III to find the distance or how far two experts agree or disagree also how far they agree or disagree from the New Average Simple Neutrosophic Cognitive Maps model and the average of the three experts 12 hidden patterns in the following. Let \bar{A} denote the average and A denote the hidden of the NASNCMs.

Now we find $d_k(E_i, E_j)$, $d_k(A, E_1)$, $d_k(\bar{A}, E_i)$ and $d_k(A, \bar{A})$ in the following.

	$d_k(E_1, E_2)$	$d_k(E_1, E_3)$	$d_k(E_2, E_3)$	$d_k(E_1, A)$	$d_k(E_2, A)$
$X_1 = (1\ 0\ 0\ 0\ 0)$	4	4	1	3	4
$X_2 = (0\ 1\ 0\ 0\ 0)$	2	3	2	1	3
$X_3 = (0\ 0\ 1\ 0\ 0)$	2	2	3	2	2
$X_4 = (0\ 0\ 0\ 1\ 0)$	3	3	3	2	3
$X_5 = (0\ 0\ 0\ 0\ 1)$	2	3	2	3	2
$X_{1,2} = (1\ 1\ 0\ 0\ 0)$	2	3	2	1	3
$X_{1,3} = (1\ 0\ 1\ 0\ 0)$	2	1	3	1	1
$X_{1,4} = (1\ 0\ 0\ 1\ 0)$	0	3	3	2	2
$X_{1,5} = (1\ 0\ 0\ 0\ 1)$	3	3	2	3	3
$X_{4,5} = (0\ 0\ 0\ 1\ 1)$	3	2	2	2	3
$X_{3,4} = (0\ 0\ 1\ 1\ 0)$	2	2	2	0	2
$X_{2,4} = (0\ 1\ 0\ 1\ 0)$	3	2	1	0	3

$d_k(E_3, A)$	\bar{A}	$d_k(E, \bar{A})$	$d_k(E_2, \bar{A})$	$d_k(E_3, \bar{A})$	$d_k(A, \bar{A})$
3	(11000)	4	1	0	4
4	(11100)	2	1	0	3
4	(11101)	1	2	1	3
3	(10011)	1	2	2	2
3	(10001)	1	1	2	3
3	(11100)	2	1	1	2
2	(11101)	1	1	2	1
2	(11111)	0	0	3	2
1	(10101)	2	1	3	3
2	(10011)	1	2	1	3
3	(01111)	2	1	2	1
2	(01111)	0	3	2	0

This is only an illustrative example and is not a real world model in which we have worked. This is more to explain the working so the answers may be little deviant. Any interested reader can work with the real world model.

We on similar lines work with some problem which has say $C = \{c_1, \dots, c_n\}$ concepts with $s + t$ experts work using the set C

with s of them work using the FCMs and t of them work on the problem with NCMs. We find the mixed new average FCMs and NCMs where we add all the $s + t$, $n \times n$ matrices and divide it by $s + t$ we use some suitable parameter α so that using α the Mixed New average NCM and FCM is obtained such that the entries are from the set $\{0, 1\}$ only. This working is similar to that of NASFCMs and NASNCMs.

Here we keep on record that we need not work with values in between the interval $[0,1]$ for the dynamical system is ultimately only going to give hidden pattern as 0 or 1 the off or on state of nodes for otherwise the dynamical system will not function. So under these conditions it is deemed fit we can work only with NASFCMs NASNCMs and mixed NASFCMs and mixed NASNCMs using elements from the set $\{0, 1, I\}$.

Interested reader can work with them using them in the real world model. Here we suggest some problems for the reader.

Problems:

1. Obtain some special features enjoyed by Average New Simple FCMs.
2. Show by a real world problem the working of NASFCMs.
3. Compare NASFCMs with combined FCMs.
4. Which of the models is better NASFCMs or combined FCMs?
5. What are the special features enjoyed by NASNCMs?
6. Exhibit by a real world model the functioning of NASNCMs.
7. Compare NASNCMs with combined NCMs.

8. Which model is better combined NCMs or NASNCMs.
9. Give a real world model and describe the functioning of the mixed new average simple FCMs and NCMs.
10. Compare NASFCMs with the overlapping FCMs.
11. Distinguish both mentioned in problem 10 by applying it in the real world problem.
12. Compare FTCMs with NASTCMs.
13. Compare both the model NTCMs with NASNTCMs by using it in a real world model.
14. Can NASFCMs be used in predicting the users web behavior?
15. Illustrate the working of NASNCMs in the users web behavior.
16. Use NASFCMs to study the bonded labour problem.
17. Can the study given problem 16 be done using NASNCMs?
18. Using problems (16) and (17) make the mixed NASNCMs and NCMs model to study the bonded labour problem.
19. Prove these new average models saves time and money.
20. Prove the advantage of using new average models eradicates the bias in taking the opinion of only few experts.

Chapter Five

INFLUENTIAL OR VITAL NODES OF FCMS AND NCMs

In this chapter we study the vital or the most influential nodes of FCMS and NCMs. We know when we have a graph a vertex which has the maximum number of vertices adjacent with it is usually considered as the vital node or the most influential node.

In this book we study the nodes in case of FCMS and NCMs. As FCMS and NCMs mainly function on the directed graph of the dynamical system we ventured to study such nodes. We saw these graphs are not like usual graphs for a node with the maximum number of edges incident to it need not in general to be vital node. This was proved by real valued problems using FCMS / NCMs model and their associated directed graphs given by the experts.

Further we for these directed graphs of the FCMS define most influential node, more influential node,

influential node, less influential node, least influential node or a passive node in a very different way.

Let $\{C_1, C_2, \dots, C_n\} = C$ be the set of nodes / attributes with which an expert works with the problem using FCMs or NCMs. The expert will give the experts opinion in the form of a directed graph say with C_1, C_2, \dots, C_n as its nodes. Suppose C_i is a node with maximum number of edges adjacent with it then in general C_i is not defined as the most influential node by us; on the contrary we define a node C_i to be the most influential node if the on state of the state vector C_i alone say $X_i = (0, 0, \dots, 0, 1, 0, \dots, 0)$ that is the i^{th} co ordinate alone is in the on state and all other nodes are in the off state then we find the effect of X_i on the dynamical system and if X_i gives the maximum number of on states of the node in the hidden pattern of the model which may be a fixed point or a limit cycle then we define that node to be the most influential node. The C_i which when on and rest of the nodes are in the off states gives maximum on states in the resultant vector is defined as the most influential node. However for a given FCMs model we can have more than one most influential node. Suppose the most influential node C_i whose initial state vector is X_i gives r number of on states of r node including the i^{th} node C_i ($r < n$).

We say the most influential node of the dynamical system of the FCMs makes $(r-1)$ nodes on. Now when we study the related graph of the FCMs it may not be the node of the graph which has the maximum number of edges adjacent to it.

So by studying the role of the node we can derive several important properties about the problem at hand. We can have more than one node for a graph of an FCMs to be a most influential node. Now a more influential node

of a FCMs will be a node C_j say $X_j = (0, \dots, 0, 1, 0, \dots, 0)$ only the j th coordinate is in the state and all other coordinates are in the off state. Suppose the hidden pattern of X_j using the dynamical system makes s of the coordinate to be in on state and $r > s$ then we have no other state vector which can give on state of more than s state vectors then we call C_j to be the more influential node of the FCMs or NCMs we may have more than one node in C to be such more influential nodes. However the vertices of these nodes may not in general contain the maximum number of edges incident to it.

Thus we have now defined the notion of more influential node and the most influential node. Now we can define on similar lines the influential node, less influential node and so on.

A node is said to be a more influential node if the on state of the node gives the on state of several nodes but the number of nodes it makes on is less than that of the most influential node. Next we can go for the just influential node and an influential node and so on.

Hence (number of on state of most influential node) $>$ (number of on state of more influential node) $>$ (number of on state of just influential node) $>$ (number of on state of influential node) $>$ (number of less influential node) $>$ (number of least influential node) $>$ (number of non influential node) for a given initial state vector.

This is the way the concept of influential node is studied. Here the authors keep on record that there influential nodes of a FCMs or NCMs are not the popular nodes called hubs or influential nodes. These are entirely a different concept varying with the problem in hand. Further it is proved beyond doubt a node with the

maximum number of edges adjacent to it in a directed graph given by an expert of the FCMs or NCMs in general is not the most influential node but it is the capacity of the node after working with the dynamical system gives in the hidden pattern with the maximum number of on state of the nodes which is addressed in this book as the most influential node.

Thus it may so happen a node with only one edge adjacent to it may be the most influential node in that problem. Thus in this study it is very clearly established that in the directed graphs of the FCMs or NCMs that is in the net working of the problem as given by an expert the concept of the most influential node is not the maximum number of edges adjacent to it. So these special class of directed graphs (or networks) do not agree with the usual concept of influential node; on the other hand a most influential node will be node on which or around which the problem spins. So such study is very vital for any one who uses FCMs or NCMs. We are the first one to make such a study. This also answers the long standing question of the graph theorists who had doubts about the influential nodes of a graph in general.

Now we have also classified the nodes as “most influential”, “more influential”, “just influential”, “influential less influential”, least influential” and “not influential” etc.,. Such study throws of new way of analysis of the problem which uses FCMs or NCMs whatever is said for the directed graphs associated with FCMs are also true in case of neutrosophic directed graphs associated with the NCMs. Here we need to study only the on state of one and only one node. For on state of two nodes simultaneously etc does not come under the purview of this study. We will illustrate these situations before we describe them more technically.

From table 1 in chapter IV we have

Initial State vectors	Hidden patterns	No.of edges incident to vertices
$X_1 = (100000)$	(100001)	2
$X_2 = (010000)$	(111111)	4
$X_3 = (001000)$	(001000)	1
$X_4 = (000100)$	(111111)	2
$X_5 = (000010)$	(111111)	3
$X_6 = (000001)$	(000001)	2

We see X_4 that is the node C_4 has only two edges incident to it yet it is also a most influential node. So the nodes C_2, C_4 and C_5 are the most influential nodes.

Refer graph G_1

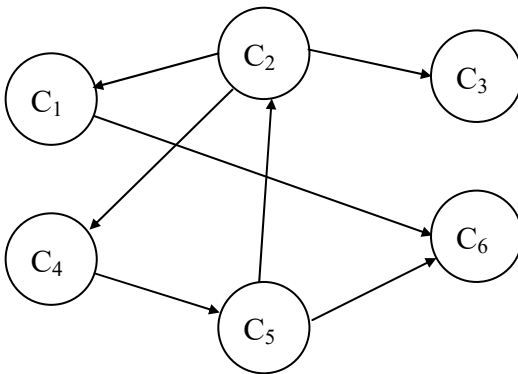

Now we remove the node C_2 and find the most influential node.

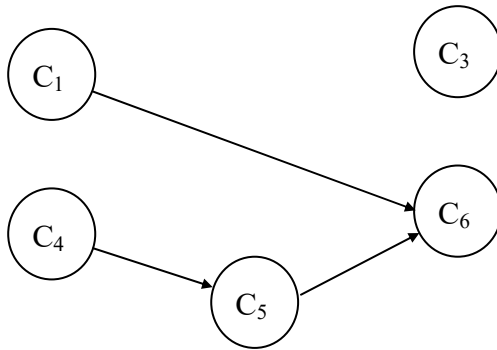

The connection matrix

$$\begin{matrix}
 & c_1 & c_3 & c_4 & c_5 & c_6 \\
 \begin{matrix} c_1 \\ c_3 \\ c_4 \\ c_5 \\ c_6 \end{matrix} & \begin{bmatrix} 0 & 0 & 0 & 0 & 1 \\ 0 & 0 & 0 & 0 & 0 \\ 0 & 0 & 0 & 1 & 0 \\ 0 & 0 & 0 & 0 & 1 \\ 0 & 0 & 0 & 0 & 0 \end{bmatrix} & = S_1.
 \end{matrix}$$

We find for $X_1 = (1\ 0\ 0\ 0\ 0)$ the hidden pattern using S_1 .

$X_1 = (1\ 0\ 0\ 0\ 0)$ gives the hidden pattern as $(1\ 0\ 0\ 0\ 1)$.
 For $X_3 = (0\ 1\ 0\ 0\ 0)$ we find the hidden pattern using S_1 .
 The hidden pattern is $(0\ 1\ 0\ 0\ 0)$.

Using $X_4 = (0\ 0\ 1\ 0\ 0)$ we find the hidden pattern using S_1 which is $(0\ 0\ 1\ 1\ 1)$.

For $X_5 = (0\ 0\ 0\ 1\ 0)$ we find the hidden pattern using S_1 to be (00111) .

For $X_6 = (0\ 0\ 0\ 0\ 1)$ we find the hidden pattern using S_1 to be $(0\ 0\ 0\ 0\ 1)$.

Thus we see the most influential node of the graph $G_1 \setminus \{C_2\}$ is still X_4 and X_5 .

So the removal of C_2 has not collapsed the system. Now we find the graph $G_1 \setminus \{C_4\}$.

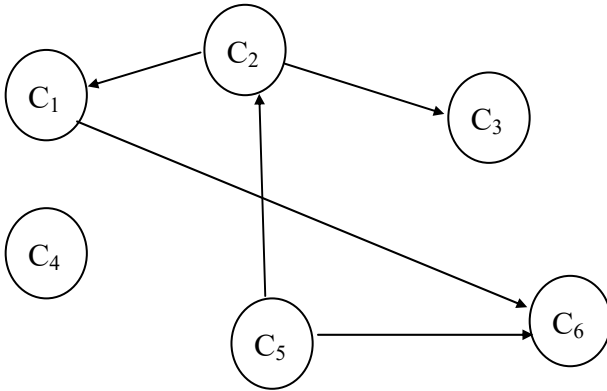

Let S_2 be the associated connection matrix which is as follows.

$$S_2 = \begin{matrix} & c_1 & c_2 & c_3 & c_5 & c_6 \\ \begin{matrix} c_1 \\ c_2 \\ c_3 \\ c_5 \\ c_6 \end{matrix} & \begin{bmatrix} 0 & 0 & 0 & 0 & 1 \\ 1 & 0 & 1 & 0 & 0 \\ 0 & 0 & 0 & 0 & 0 \\ 0 & 1 & 0 & 0 & 1 \\ 0 & 0 & 0 & 0 & 0 \end{bmatrix} \end{matrix}.$$

Now using $X_1 = (1 \ 0 \ 0 \ 0 \ 0)$ we find the hidden pattern using S_2 which is $(1 \ 0 \ 0 \ 0 \ 1)$.

Now for $X_2 = (0 \ 1 \ 0 \ 0 \ 0)$ we find the hidden pattern using S_2 which is $(1 \ 1 \ 1 \ 0 \ 1)$.

For $X_3 = (0\ 0\ 1\ 0\ 0)$ we using S_2 find the hidden pattern which is $(0\ 0\ 1\ 0\ 0)$.

For $X_5 = (0\ 0\ 0\ 1\ 0)$ we find the hidden pattern using S_2 which is $(1\ 1\ 1\ 1\ 1)$.

Now for $X_6 = (0\ 0\ 0\ 0\ 1)$ we find the hidden pattern using S_2 which is as follows $(0\ 0\ 0\ 0\ 1)$.

The most influential node is $X_5 = (0\ 0\ 0\ 1\ 0)$; C_5 is the most influence node. Though C_4 is very influential its removal has weakened only the most influential node C_2 but has no impact on the other most influential node C_5 .

Now $G_1 \setminus \{C_5\}$ gives the following graph.

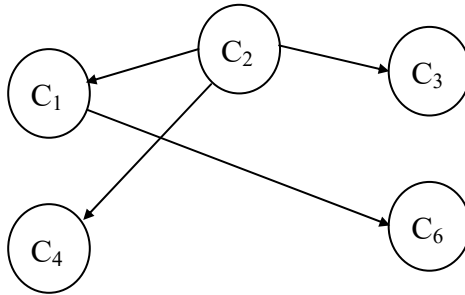

Let S_3 be the connection matrix of the graph $G_1 \setminus \{C_5\}$.

$$S_3 = \begin{matrix} & c_1 & c_2 & c_3 & c_4 & c_6 \\ \begin{matrix} c_1 \\ c_2 \\ c_3 \\ c_4 \\ c_6 \end{matrix} & \begin{bmatrix} 0 & 0 & 0 & 0 & 1 \\ 1 & 0 & 1 & 1 & 0 \\ 0 & 0 & 0 & 0 & 0 \\ 0 & 0 & 0 & 0 & 0 \\ 0 & 0 & 0 & 0 & 0 \end{bmatrix} & \end{matrix}.$$

Now $X_1 = (1\ 0\ 0\ 0\ 0)$ on the dynamical system S_3 yields $(1\ 0\ 0\ 0\ 1)$.

$X_2 = (0\ 1\ 0\ 0\ 0)$ on S_3 yields $(1\ 1\ 1\ 1\ 1)$.

$X_3 = (0\ 0\ 1\ 0\ 0)$ on S_3 yields $(0\ 0\ 1\ 0\ 0)$.

$X_4 = (0\ 0\ 0\ 1\ 0)$ on S_3 yields $(0\ 0\ 0\ 1\ 0)$.

$X_6 = (0\ 0\ 0\ 0\ 1)$ on S_3 yields $(0\ 0\ 0\ 0\ 1) = X_6$.

Thus the most influential node X_4 becomes a least influential node. However X_2 remains as the most influential node.

Thus C_5 is most influential vital node for it can also affect the most influential node to become a least influential node.

Now we study the graph G_2 given in chapter IV.

Initial State vectors	Hidden patterns	Number of edges incident to the vertices
$X_1 = (100000)$	(111111)	2
$X_2 = (010000)$	(010111)	2
$X_3 = (001000)$	(111111)	3
$X_4 = (000100)$	(000111)	4
$X_5 = (000010)$	(000111)	3
$X_6 = (000001)$	(000111)	2

Only the nodes X_1 and X_3 are the most influential node and X_2 is more influential node.

However the nodes X_4 , X_5 and X_6 are just influential node. There is no influential node or less influential node or least influential node for this particular system.

Now $G_2 \setminus C_3$ gives the following graph.

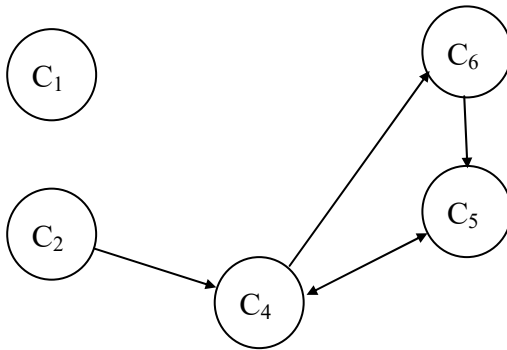

The related connection matrix R_1 of the graph $G_2 \setminus C_3$ is as follows:

$$R_1 = \begin{matrix} & c_1 & c_2 & c_4 & c_5 & c_6 \\ \begin{matrix} c_1 \\ c_2 \\ c_4 \\ c_5 \\ c_6 \end{matrix} & \begin{bmatrix} 0 & 0 & 0 & 0 & 0 \\ 0 & 0 & 1 & 0 & 0 \\ 0 & 0 & 0 & 1 & 1 \\ 0 & 0 & 1 & 0 & 0 \\ 0 & 0 & 0 & 1 & 0 \end{bmatrix} \end{matrix}.$$

Now using R_1 we find the hidden pattern of $X_1 = (1\ 0\ 0\ 0\ 0)$ which is $(1\ 0\ 0\ 0\ 0)$.

The hidden pattern of $X_2 = (01000)$ using the dynamical system R_1 is $(0\ 1\ 1\ 1\ 1)$.

The hidden pattern of the node $X_4 = (0\ 0\ 1\ 0\ 0)$ is as follows: $(0\ 0\ 1\ 1\ 1)$.

Now the hidden pattern of $X_5 = (0\ 0\ 0\ 1\ 0)$ is given by $(0\ 0\ 1\ 1\ 1)$. Finally the hidden pattern of $X_6 = (0\ 0\ 0\ 0\ 1)$ is $(0\ 0\ 1\ 1\ 1)$.

Thus more influential node becomes the most influential node and all the other three nodes are unaffected the removal of the most influential node. Now we see the most influential node viz X_1 becomes the least influential node.

Now we remove the other most influential node C_1 from the graph G_2 . $G_2 \setminus \{C_1\}$ gives the following graph.

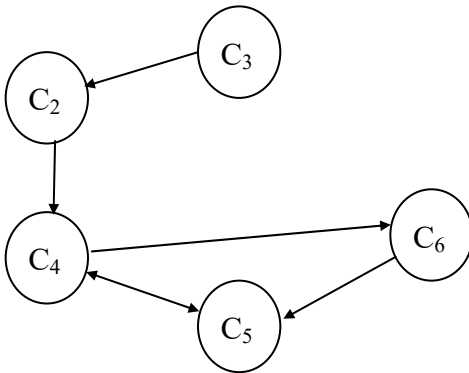

$$R_2 = \begin{matrix} & c_2 & c_3 & c_4 & c_5 & c_6 \\ \begin{matrix} c_2 \\ c_3 \\ c_4 \\ c_5 \\ c_6 \end{matrix} & \begin{bmatrix} 0 & 0 & 1 & 0 & 0 \\ 1 & 0 & 0 & 0 & 0 \\ 0 & 0 & 0 & 1 & 1 \\ 0 & 0 & 1 & 0 & 0 \\ 0 & 0 & 0 & 1 & 0 \end{bmatrix} \end{matrix}.$$

We find the hidden pattern of the on state of the nodes C_4, C_2, C_3, C_5 and C_6 .

Let $X_2 = (1\ 0\ 0\ 0\ 0)$, to find the hidden pattern of X_2 using R_2 . The hidden pattern of X_2 is $(1\ 0\ 1\ 1\ 1)$.

The hidden pattern of the node initial state vector $X_3 = (0\ 1\ 0\ 0\ 0)$ is $(1\ 1\ 1\ 1\ 1)$. For the initial state of $X_4 = (0\ 0\ 1\ 0\ 0)$ the hidden pattern is $(0\ 0\ 1\ 1\ 1)$.

The hidden pattern for the state vector $X_5 = (0\ 0\ 0\ 1\ 0)$ is $(0\ 0\ 1\ 1\ 1)$. Finally the hidden pattern for the initial state vector $X_6 = (0\ 0\ 0\ 0\ 1)$ is $(0\ 0\ 1\ 1\ 1)$. Thus X_3 continues to be the most influential node even if the most influential node C_1 is removed.

So C_3 happens to be the better of the two influential nodes C_1 and C_3 .

Now we analyse the graph III of the problem.

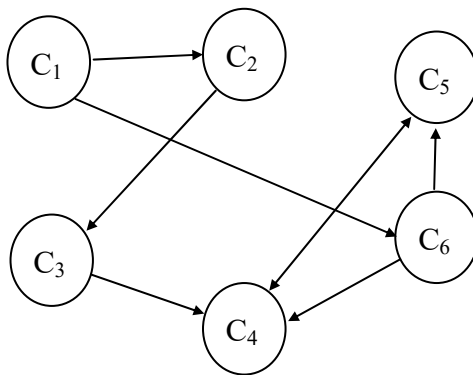

Now the influential nodes are tabled using the connection matrix M_3 of the graph G_3 in the following.

Initial state vectors	Hidden patterns	No. of edges incident to vertices
$X_1 = (100000)$	(111110)	2
$X_2 = (010000)$	(011110)	2
$X_3 = (001000)$	(001110)	2
$X_4 = (000100)$	(000110)	4
$X_5 = (000010)$	(000110)	2
$X_6 = (000001)$	(111111)	3

The most influential node is X_6 , the more influential node is X_1 . However the vertex C_4 which has maximum number of edges adjacent to it is the least influential node of the system. Now $G_3 \setminus C_6$ gives the following graph.

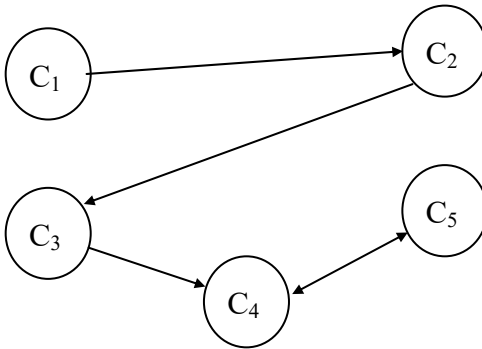

The matrix of $G_3 \setminus C_6$ is

$$S_1 = \begin{matrix} & c_1 & c_2 & c_3 & c_4 & c_5 \\ \begin{matrix} c_1 \\ c_2 \\ c_3 \\ c_4 \\ c_5 \end{matrix} & \begin{bmatrix} 0 & 1 & 0 & 0 & 0 \\ 0 & 0 & 1 & 0 & 0 \\ 0 & 0 & 0 & 1 & 0 \\ 0 & 0 & 0 & 0 & 1 \\ 0 & 0 & 0 & 1 & 0 \end{bmatrix} & . \end{matrix}$$

Now using S_1 we find the most influential node from the table calculated.

Initial State vectors	Hidden patterns	No.of edges incident to vertices
$X_1 = (10000)$	(11111)	1
$X_2 = (01000)$	(01111)	2
$X_3 = (00100)$	(00111)	2
$X_4 = (00010)$	(00011)	3
$X_5 = (00001)$	(00011)	1

The most influential node now is X_1 and the more influential node is X_2 .

So the removal of the most influential node X_6 makes the more influential node X_1 to be the most influential node and so on.

Now we remove the node X_1 from G_3 .

We get the following graph $G_3 \setminus C_1 =$

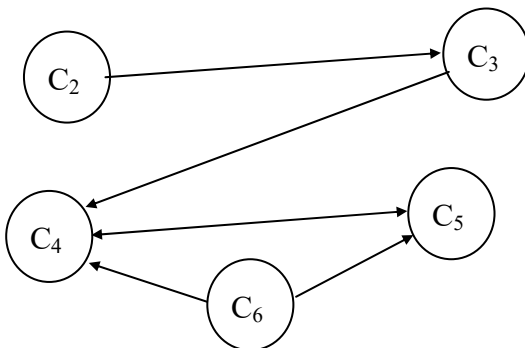

The connection matrix of the graph $G_3 \setminus C_1$ is as follows:

$$S_2 = \begin{matrix} & c_2 & c_3 & c_4 & c_5 & c_6 \\ \begin{matrix} c_2 \\ c_3 \\ c_4 \\ c_5 \\ c_6 \end{matrix} & \begin{bmatrix} 0 & 1 & 0 & 0 & 0 \\ 0 & 0 & 1 & 0 & 0 \\ 0 & 0 & 0 & 1 & 0 \\ 0 & 0 & 1 & 0 & 0 \\ 0 & 0 & 1 & 1 & 0 \end{bmatrix} \end{matrix}.$$

Now we tabulate the hidden patterns;

Initial State vectors	Hidden patterns	No. of edges incident to vertices
$X_2 = (10000)$	(11110)	1
$X_3 = (01000)$	(01110)	2
$X_4 = (00100)$	(00110)	4
$X_5 = (00010)$	(00110)	3
$X_6 = (00001)$	(00111)	2

X_2 happens to be the most influential node X_3 and X_6 are the more influential node. Removal of the more influential node C_1 makes the most influential node X_6 into a more influential node.

Thus we will now remove X_5 from the graph G_3 .

$$G_3 \setminus C_5 =$$

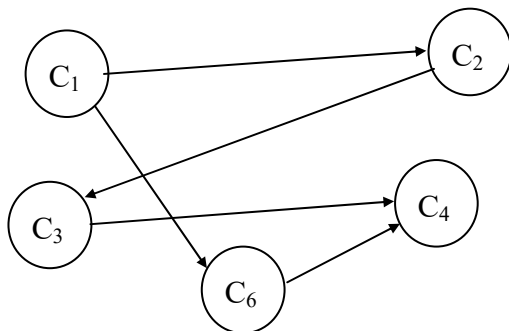

The associated connection matrix of $G_3 \setminus C_5$ is as follows:

$$T_1 = \begin{matrix} & c_1 & c_2 & c_3 & c_4 & c_6 \\ \begin{matrix} c_1 \\ c_2 \\ c_3 \\ c_4 \\ c_6 \end{matrix} & \begin{bmatrix} 0 & 1 & 0 & 0 & 1 \\ 0 & 0 & 1 & 0 & 0 \\ 0 & 0 & 0 & 1 & 0 \\ 0 & 0 & 0 & 0 & 0 \\ 0 & 0 & 0 & 1 & 0 \end{bmatrix} \end{matrix}.$$

The table of influential nodes is given in the following:

Initial State vectors	Hidden patterns	No.of edges incident to vertices
$X_1 = (10000)$	(11111)	2
$X_2 = (01000)$	(01110)	2
$X_3 = (00100)$	(00110)	2
$X_4 = (00010)$	(00010)	2
$X_6 = (00001)$	(00001)	2

Most influential node is X_1 , the non influential nodes are X_4 and X_6 .

However all the fives nodes have the same number of edges incident to it. So the removal of the least influential node into a non influential node. We call such nodes as the most powerful nodes of the dynamical system.

Powerful nodes in general need not be the most influential node. Likewise the most influential node need not be a powerful node. Thus a most powerful node is a node whose deletion makes the most influential node into a non influential node.

The more powerful node is that node whose deletion makes the more influential node or most influential node into a least influential node. Likewise the other types of powerful nodes are defined.

Now we study the graph G_4 .

Initial State vectors	Hidden patterns	No.of edges incident to vertices
$X_1 = (100000)$	(110111)	3
$X_2 = (010000)$	(010100)	2
$X_3 = (001000)$	(111111)	2
$X_4 = (000100)$	(010100)	5
$X_5 = (000010)$	(010111)	3
$X_6 = (000001)$	(010111)	3

The most influential node is C_3 and the least influential nodes are X_4 and X_2 .

X_4 has the most number of edges incident to it C_1 is the more influential node. There is no node which is non influential.

Let us study the graph G_4 with node C_3 removed which is as follows:

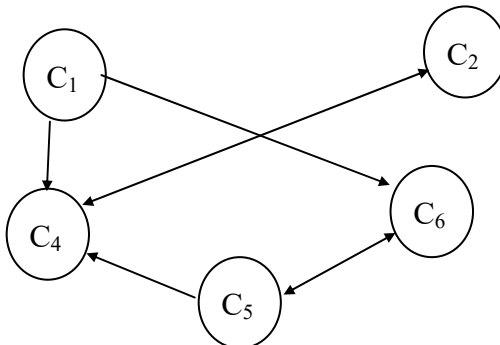

The connection matrix of $G_4 \setminus C_3$ is as follows:

$$\begin{matrix}
 & c_1 & c_2 & c_4 & c_5 & c_6 \\
 \begin{matrix} c_1 \\ c_2 \\ c_4 \\ c_5 \\ c_6 \end{matrix} & \begin{bmatrix} 0 & 0 & 1 & 0 & 1 \\ 0 & 0 & 1 & 0 & 0 \\ 0 & 1 & 0 & 0 & 0 \\ 0 & 0 & 1 & 0 & 1 \\ 0 & 0 & 0 & 1 & 0 \end{bmatrix} & = L_1.
 \end{matrix}$$

Using L_1 we tabulate the hidden pattern of the on state of the nodes C_1, C_2, C_4, C_5 and C_6 in the following table.

Initial State vectors	Hidden patterns	No.of edges incident to vertices
$X_1 = (10000)$	(11111)	2
$X_2 = (01000)$	(01100)	2
$X_4 = (00100)$	(01100)	4
$X_5 = (00010)$	(01111)	1
$X_6 = (00001)$	(01111)	3

The most influential node is X_1 , however it has only 2 edges adjacent to it.

The more influential nodes are X_5 and X_6 however the number of edges adjacent to X_5 is only one the least number of edges but it is the more influential node.

However there is no non influential nodes in this case.

Now we find the graph $G_4 \setminus C_4$ which is as follows:

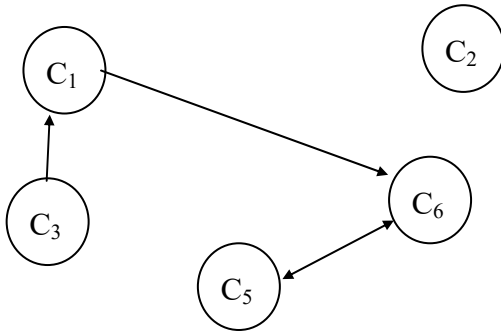

The connection matrix D_1 of the graph $G_4 \setminus C_4$ is as follows:

$$D_1 = \begin{matrix} & c_1 & c_2 & c_3 & c_5 & c_6 \\ \begin{matrix} c_1 \\ c_2 \\ c_3 \\ c_5 \\ c_6 \end{matrix} & \begin{bmatrix} 0 & 0 & 0 & 0 & 1 \\ 0 & 0 & 0 & 0 & 0 \\ 1 & 0 & 0 & 0 & 0 \\ 0 & 0 & 0 & 0 & 1 \\ 0 & 0 & 0 & 1 & 0 \end{bmatrix} \end{matrix}.$$

The table of hidden patterns to find the influential node is as follows:

Initial State vectors	Hidden patterns	No. of edges incident to vertices
$X_1 = (10000)$	(10011)	2
$X_2 = (01000)$	(01000)	0
$X_3 = (00100)$	(10111)	1
$X_5 = (00010)$	(00011)	2
$X_6 = (00001)$	(00011)	3

From the table it is clear that the non influential node is C_2 as there is only zero number of edges incident to it.

Most influential node is X_3 and more influential node is X_1 .

Just influential nodes are C_5 and C_6 .

However C_6 has the maximum number of edges incident to it and C_3 has the least number of edges adjacent to it viz. one edge but it is the most influential node.

However the edge C_2 is non influential as it has no edge adjacent towards it.

Consider the graph $G_4 \setminus C_6$ which is as follows:

$$G_4 \setminus C_6 =$$

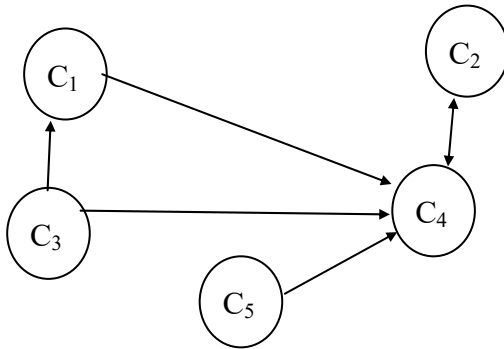

Now we give the connection matrix of the graph $G_4 \setminus C_6$ and is as follows:

$$V_1 = \begin{matrix} & c_1 & c_2 & c_3 & c_4 & c_5 \\ \begin{matrix} c_1 \\ c_2 \\ c_3 \\ c_4 \\ c_5 \end{matrix} & \begin{bmatrix} 0 & 0 & 0 & 1 & 0 \\ 0 & 0 & 0 & 1 & 0 \\ 1 & 0 & 0 & 1 & 0 \\ 0 & 1 & 0 & 0 & 0 \\ 0 & 0 & 0 & 1 & 0 \end{bmatrix} \end{matrix}.$$

The table of hidden patterns using the dynamical system V_1 is given by the following table.

Initial State vectors	Hidden patterns	No.of edges incident to vertices
$X_1 = (10000)$	(11010)	2
$X_2 = (01000)$	(01010)	2
$X_3 = (00100)$	(11110)	2
$X_4 = (00010)$	(01010)	5
$X_5 = (00001)$	(01011)	1

The most influential node is C_3 but the number of edges incident to it is 2.

However the node C_4 has the highest number of nodes adjacent to it how ever it is not even the most influential node only a just influential node.

Now we study $G_4 \setminus C_2$ directed graph and FCMs associated with it.

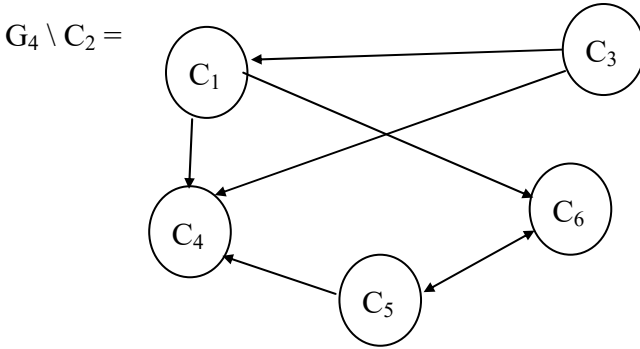

The related connection matrix of the graph $G_4 \setminus C_2$ is as follows:

$$W_1 = \begin{matrix} & c_1 & c_3 & c_4 & c_5 & c_6 \\ \begin{matrix} c_1 \\ c_3 \\ c_4 \\ c_5 \\ c_6 \end{matrix} & \begin{bmatrix} 0 & 0 & 1 & 0 & 1 \\ 1 & 0 & 1 & 0 & 0 \\ 0 & 0 & 0 & 0 & 0 \\ 0 & 0 & 1 & 0 & 1 \\ 0 & 0 & 0 & 1 & 0 \end{bmatrix} \end{matrix}.$$

Now we get the table of hidden patterns.

Initial State vectors	Hidden patterns	No.of edges incident to vertices
$X_1 = (10000)$	(10111)	3
$X_3 = (01000)$	(11111)	2
$X_4 = (00100)$	(00100)	3
$X_5 = (00010)$	(00111)	3
$X_6 = (00001)$	(00111)	3

The most influential node is C_3 which has the least number of edges adjacent to it. However C_4 which has 3 edges incident to it however it is a non influential node. The more influential node is C_1 and the just influential nodes are C_5 and C_6 .

Now we study the case for the NCMs given in example 4.2.

Consider the neutrosophic graph $G_1 \setminus \{C_2\}$ which is as follows:

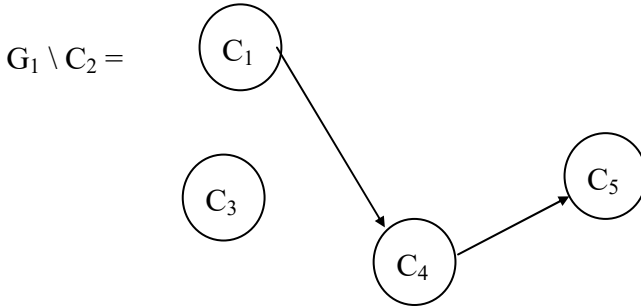

The table of the graph G_1 is as follows:

Initial State vectors	Hidden patterns	No.of edges incident to vertices
$X_1 = (10000)$	(11111)	2
$X_2 = (01000)$	(01101)	4
$X_3 = (00100)$	(01101)	1
$X_4 = (00010)$	(00011)	2
$X_5 = (00001)$	(00001)	2

C_1 is the most influential node. C_2 and C_3 are more influential nodes but C_3 has only one edge incident to it

but C_2 has four edges incident to it. However X_5 is a non influential node.

Now the connection matrix of $G_1 \setminus C_2$ is as follows;

$$S_1 = \begin{matrix} & c_1 & c_3 & c_4 & c_5 \\ \begin{matrix} c_1 \\ c_3 \\ c_4 \\ c_5 \end{matrix} & \begin{bmatrix} 0 & 0 & 1 & 0 \\ 0 & 0 & 0 & 0 \\ 0 & 0 & 0 & 1 \\ 0 & 0 & 0 & 0 \end{bmatrix} \end{matrix} .$$

The table of comparison of influential nodes using matrix S_1 is as follows:

Initial State vectors	Hidden patterns	No.of edges incident to vertices
$X_1 = (1000)$	(1011)	1
$X_3 = (0100)$	(0100)	0
$X_4 = (0010)$	(0011)	2
$X_5 = (0001)$	(0001)	1

X_2 is a special node for C_3 which is a more influential node is made into a non influential node.

Now we remove the node C_1 from the graph G_1

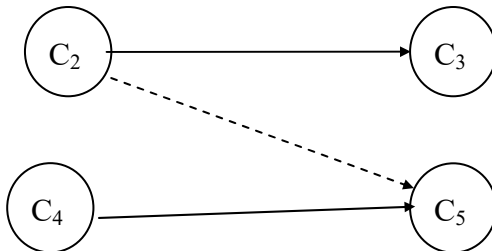

The neutrosophic connection matrix of the graph $G_1 \setminus C_1$ is as follows:

$$M_1 = \begin{matrix} & c_2 & c_3 & c_4 & c_5 \\ \begin{matrix} c_2 \\ c_3 \\ c_4 \\ c_5 \end{matrix} & \begin{bmatrix} 0 & 1 & 0 & 1 \\ 1 & 0 & 0 & 0 \\ 0 & 0 & 0 & 1 \\ 0 & 0 & 0 & 0 \end{bmatrix} \end{matrix}.$$

The table of hidden pattern using the matrix M_1 is as follows:

Initial State vectors	Hidden patterns	No.of edges incident to vertices
$X_2 = (1000)$	(110I)	3
$X_3 = (0100)$	(110I)	2
$X_4 = (0010)$	(0011)	1
$X_5 = (0001)$	(0001)	1

The most influential nodes are C_2 and C_3 . C_3 and C_5 non influential nodes.

More influential node C_3 is made into a most influential node and so on.

This type of study can be made to study the influential nodes as well as powerful nodes of the problem.

Consider the graph G_2 of the example 4.2.

The table of hidden patterns is as follows.

Initial State vectors	Hidden patterns	No.of edges incident to vertices
$X_1 = (10000)$	(10000)	1
$X_2 = (01000)$	(11101)	2
$X_3 = (00100)$	(10101)	2
$X_4 = (00010)$	(11111)	2
$X_5 = (00001)$	(10001)	3

The most influential node is C_4 and more influential node is C_2 . C_1 is a non influential node.

Now we study the system with C_1 removed. Consider the graph $G_2 \setminus C_1$.

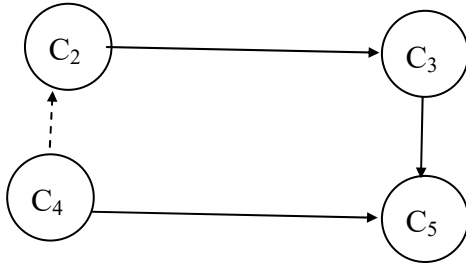

The connection matrix of $G_2 \setminus C_1$ is as follows:

$$P_1 = \begin{matrix} & \begin{matrix} c_2 & c_3 & c_4 & c_5 \end{matrix} \\ \begin{matrix} c_2 \\ c_3 \\ c_4 \\ c_5 \end{matrix} & \begin{bmatrix} 0 & 1 & 0 & 0 \\ 0 & 0 & 0 & 1 \\ I & 0 & 0 & 1 \\ 0 & 0 & 0 & 0 \end{bmatrix} \end{matrix} .$$

Now the table of hidden pattern using P_1 is as follows:

Initial State vectors	Hidden patterns	No.of edges incident to vertices
$X_2 = (1000)$	(1101)	2
$X_3 = (0100)$	(0101)	2
$X_4 = (0010)$	(1111)	2
$X_5 = (0001)$	(0001)	2

Removal the node C_1 does not alter the most influential node. However C_5 happens to be a non influential node. Consider $G_2 \setminus C_2$ the graph which is as follows:

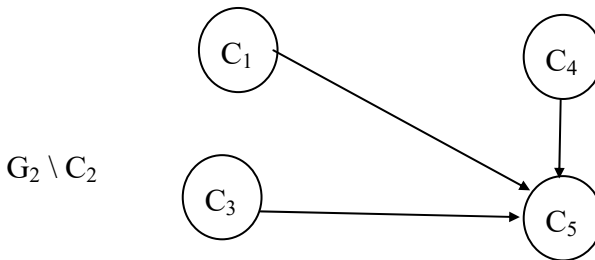

The connection matrix of $G_2 \setminus C_2$ is as follows:

$$W_1 = \begin{matrix} & c_1 & c_3 & c_4 & c_5 \\ \begin{matrix} c_1 \\ c_3 \\ c_4 \\ c_5 \end{matrix} & \begin{bmatrix} 0 & 0 & 0 & 0 \\ 0 & 0 & 0 & 1 \\ 0 & 0 & 0 & 1 \\ 1 & 0 & 0 & 0 \end{bmatrix} \end{matrix} .$$

The table of hidden patterns is as follows:

Initial State vectors	Hidden patterns	No.of edges incident to vertices
$X_1 = (1000)$	(1000)	1
$X_3 = (0100)$	(1101)	1
$X_4 = (0010)$	(1011)	1
$X_5 = (0001)$	(1001)	3

Clearly C_5 is the node which has maximum number of edges incident to it but it is not the most influential node.

C_3 and C_4 which has only one edge incident towards it happens to be the most influential node.

However C_1 happens to be a non influential node.

The node C_2 is not a powerful node for the change made by it on the NCM is negligible.

Consider the graph $G_2 \setminus C_3$ which is follows:

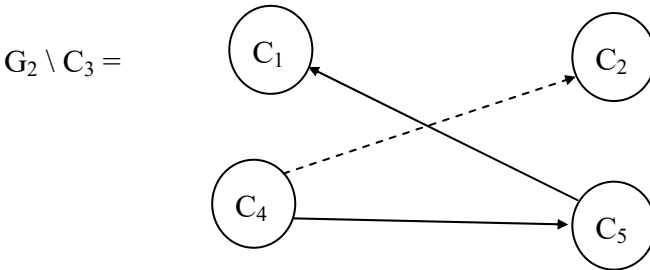

The connection matrix W_1 of the graph $G_2 \setminus C_3$ is as follows;

$$W_1 = \begin{matrix} & c_1 & c_2 & c_4 & c_5 \\ \begin{matrix} c_1 \\ c_2 \\ c_4 \\ c_5 \end{matrix} & \begin{bmatrix} 0 & 0 & 0 & 0 \\ 0 & 0 & 0 & 0 \\ 0 & 1 & 0 & 1 \\ 1 & 0 & 0 & 0 \end{bmatrix} \end{matrix}.$$

Now using W_1 we find the hidden pattern is as follows.

Initial State vectors	Hidden patterns	No.of edges incident to vertices
$X_1 = (1000)$	(1000)	1
$X_2 = (0100)$	(0100)	1
$X_4 = (0010)$	(1111)	2
$X_5 = (0001)$	(1001)	2

X_4 is the most influential node and two nodes X_1 and X_2 are non influential.

Now we study the graph $G_2 \setminus C_4$ which is as follows:

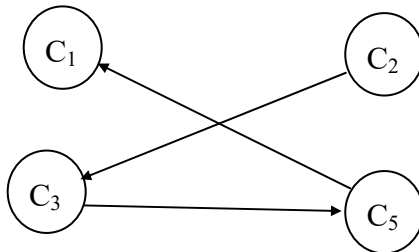

The connection matrix of $G_2 \setminus C_4$ is as follows:

$$T_1 = \begin{matrix} & c_1 & c_2 & c_3 & c_5 \\ \begin{matrix} c_1 \\ c_2 \\ c_3 \\ c_5 \end{matrix} & \begin{bmatrix} 0 & 0 & 0 & 0 \\ 0 & 0 & 1 & 0 \\ 0 & 0 & 0 & 1 \\ 1 & 0 & 0 & 0 \end{bmatrix} \end{matrix}.$$

The table of hidden pattern is as follows.

Initial State vectors	Hidden patterns	No.of edges incident to vertices
$X_1 = (1000)$	(1000)	1
$X_2 = (0100)$	(1111)	1
$X_3 = (0010)$	(1011)	2
$X_5 = (0001)$	(1001)	2

C_2 is the most influential node. Thus the removal of the most influential node. C_4 makes the more influential node C_2 to be the most influential node and nothing more.

Now consider the graph $G_2 \setminus C_5$ which is as follows.

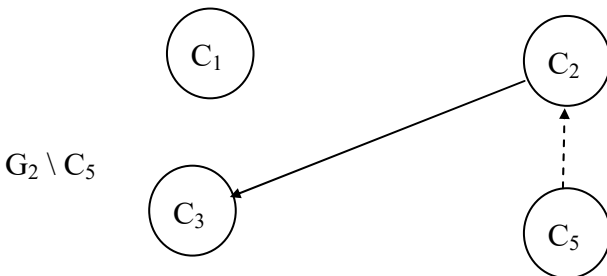

The connection matrix associated with $G_2 \setminus C_5$ is as follows:

$$P_1 = \begin{matrix} & c_1 & c_2 & c_3 & c_4 \\ \begin{matrix} c_1 \\ c_2 \\ c_3 \\ c_4 \end{matrix} & \begin{bmatrix} 0 & 0 & 0 & 0 \\ 0 & 0 & 1 & 0 \\ 0 & 0 & 0 & 0 \\ 0 & I & 0 & 0 \end{bmatrix} \end{matrix}.$$

The hidden pattern of the nodes is given by the following table.

Initial State vectors	Hidden patterns	No.of edges incident to vertices
$X_1 = (1\ 0\ 0\ 0)$	$(1\ 0\ 0\ 0)$	0
$X_2 = (0\ 1\ 0\ 0)$	$(0\ 1\ 1\ 0)$	2
$X_3 = (0\ 0\ 1\ 0)$	$(0\ 0\ 1\ 0)$	1
$X_4 = (0\ 0\ 0\ 1)$	$(0\ I\ I\ 1)$	1

This removal of node C_5 makes X_4 the most influential nodes which has only one edge adjacent to it.

The nodes C_1 and C_3 are the non influential nodes.

Now we study the graph G_3 . The table of hidden patterns is as follows.

Initial State vectors	Hidden patterns	No.of edges incident to vertices
$X_1 = (10000)$	(11000)	2
$X_2 = (01000)$	(11000)	4
$X_3 = (00100)$	(11111)	1

$X_4 = (00010)$	(11011)	4
$X_5 = (00001)$	(11011)	3

The least number of edges are incident towards C_3 and C_3 is the most influential node C_4 and C_5 are more influential nodes.

There is no non influential node.

We now study the graph $G_3 \setminus C_1$ which is as follows:

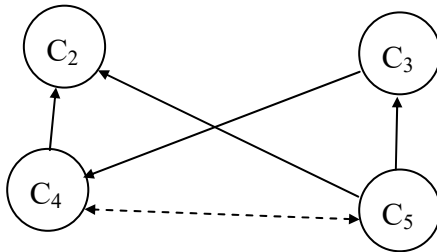

$G_3 \setminus C_1$.

The connection matrix of $G_3 \setminus C_1$ is as follows:

$$B_1 = \begin{matrix} & c_2 & c_3 & c_4 & c_5 \\ \begin{matrix} c_2 \\ c_3 \\ c_4 \\ c_5 \end{matrix} & \begin{bmatrix} 0 & 0 & 0 & 0 \\ 0 & 0 & 1 & 0 \\ 1 & 0 & 0 & 1 \\ 1 & 0 & 1 & 0 \end{bmatrix} \end{matrix}.$$

The table of hidden pattern is as follows:

Initial State vectors	Hidden patterns	No.of edges incident to vertices
$X_2 = (1000)$	(1000)	2
$X_3 = (0100)$	(1111)	1
$X_4 = (0010)$	(1011)	4
$X_5 = (0001)$	(1011)	3

The least number of edges is incident to the node C_3 and it is the most influential node and C_2 is the non influential node though it has two edges incident towards it. X_4 and X_5 are more influential nodes.

Consider the graph $G_3 \setminus C_2$ is as follows.

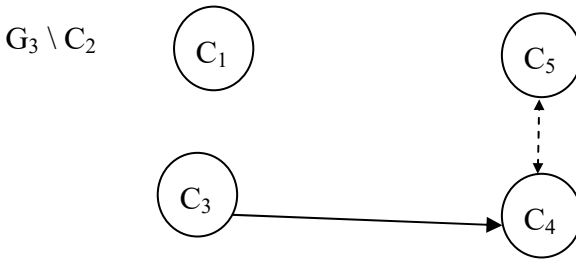

The connection matrix associated with $G_3 \setminus C_2$ is as follows:

$$E_1 = \begin{matrix} & c_1 & c_3 & c_4 & c_5 \\ \begin{matrix} c_1 \\ c_3 \\ c_4 \\ c_5 \end{matrix} & \begin{bmatrix} 0 & 0 & 0 & 0 \\ 0 & 0 & 1 & 0 \\ 0 & 0 & 0 & I \\ 0 & 0 & I & 0 \end{bmatrix} \end{matrix} .$$

The table of hidden patterns is as follows:

Initial State vectors	Hidden patterns	No.of edges incident to vertices
$X_1 = (1000)$	(1000)	0
$X_3 = (0100)$	(0111)	1
$X_4 = (0010)$	(0011)	3
$X_5 = (0001)$	(0011)	2

X_3 is the most influential node and X_4 and X_5 are more influential nodes.

X_1 is non influential node consider the graph $G_3 \setminus C_3$ which is as follows.

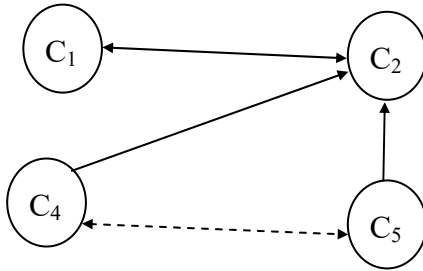

The connection matrix associated with $G_3 \setminus C_3$ is as follows:

$$Y_1 = \begin{matrix} & c_1 & c_2 & c_4 & c_5 \\ \begin{matrix} c_1 \\ c_2 \\ c_4 \\ c_5 \end{matrix} & \begin{bmatrix} 0 & 1 & 0 & 0 \\ 1 & 0 & 0 & 0 \\ 0 & 1 & 0 & 1 \\ 0 & 1 & 1 & 0 \end{bmatrix} \end{matrix} .$$

We give the following table of hidden patterns using the connection matrix Y_1

Initial State vectors	Hidden patterns	No.of edges incident to vertices
$X_1 = (1000)$	(1100)	2
$X_2 = (0100)$	(1100)	4
$X_4 = (0010)$	(1111)	3
$X_5 = (0001)$	(1111)	3

The most influential nodes are X_4 and X_5 .

Every node is influential.

This is a unique one in which both the most influential nodes have the maximum number of edges incident to it.

Now consider the graph $G_3 \setminus C_5$ which is given in the following.

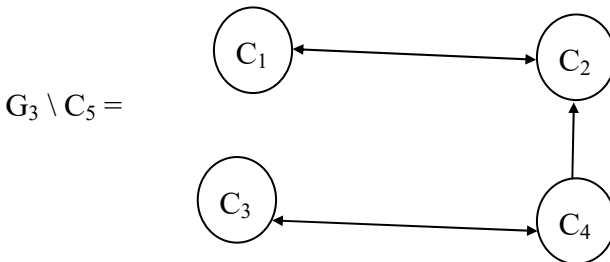

The connection matrix of $G_3 \setminus C_5$ is as follows.

$$D_1 = \begin{matrix} & c_1 & c_2 & c_3 & c_4 \\ \begin{matrix} c_1 \\ c_2 \\ c_3 \\ c_4 \end{matrix} & \begin{bmatrix} 0 & 1 & 0 & 0 \\ 1 & 0 & 0 & 0 \\ 0 & 0 & 1 & 0 \\ 0 & 1 & 0 & 0 \end{bmatrix} \end{matrix}.$$

The table of comparison of the NCMs associated with the graph $G_3 \setminus C_5$ which is as follows:

Initial State vectors	Hidden patterns	No.of edges incident to vertices
$X_1 = (1000)$	(1100)	2
$X_2 = (0100)$	(1100)	3
$X_3 = (0010)$	(0010)	1
$X_4 = (0001)$	(1101)	2

The most influential node is X_4 .

X_3 is the non influential node.

Consider the graph $G_3 \setminus C_4$ which is as follows:

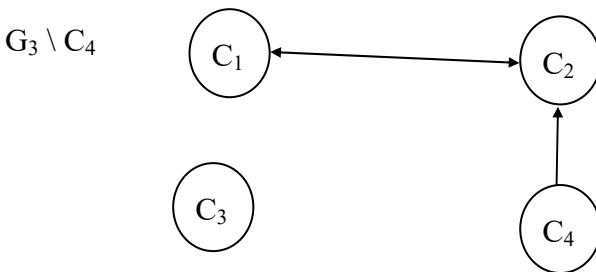

The connection matrix associated with $G_3 \setminus C_4$ is as follows:

$$F_1 = \begin{matrix} & c_1 & c_2 & c_3 & c_4 \\ \begin{matrix} c_1 \\ c_2 \\ c_3 \\ c_4 \end{matrix} & \begin{bmatrix} 0 & 1 & 0 & 0 \\ 1 & 0 & 0 & 0 \\ 0 & 0 & 0 & 0 \\ 0 & 1 & 0 & 0 \end{bmatrix} \end{matrix}.$$

The table of hidden pattern is as follows:

Initial State vectors	Hidden patterns	No.of edges incident to vertices
$X_1 = (1000)$	(1100)	2
$X_2 = (0100)$	(1100)	3
$X_3 = (0010)$	(0010)	0
$X_4 = (0001)$	(1101)	1

The most influential node is X_5 (C_5) which has the least number of edges adjacent to it. However C_3 is the non influential node. Now having studied about the most influential node, more influential node and so on.

From the study of influential node we can also study the powerful node the removal of which will collapse the system.

We suggest a few problems.

Problems:

1. Obtain the special contributing feature of the ‘most influential node’, ‘more influential node’ and so on.
2. Does there exist a directed graph of a FCM or NCM which is such that every node has equal number of edges incident to it?

3. Show using real world problems that a node with one edge incident to it can also be a most influential node.
4. Prove that in any NCM or FCM removal of a most influential node need not result in the collapsing of the dynamical system.
5. Prove for real world problem in which FCMs or NCMs are used a most influential node in general need not be the most powerful node.
6. Find any interesting relation that exist between the most influential node and the more powerful node.
7. Can there be a NCM or FCM associated with a real world problem in which every node is the most influential node?
8. Can there be a NCM or FCM in which every node is a most powerful node?
9. Let G be the graph associated with a FCM

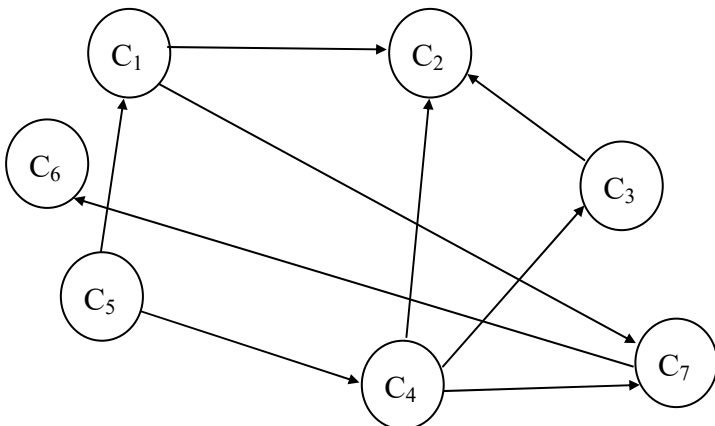

- (i) Find the most influential node of the FCMs associated with graph G .
- (ii) Find the most influential nodes of $G \setminus C_i$; $1 \leq i \leq 7$.
- (iii) Does the FCMs contain most powerful nodes?

10. Let G be the directed neutrosophic graph associated with the NCM.

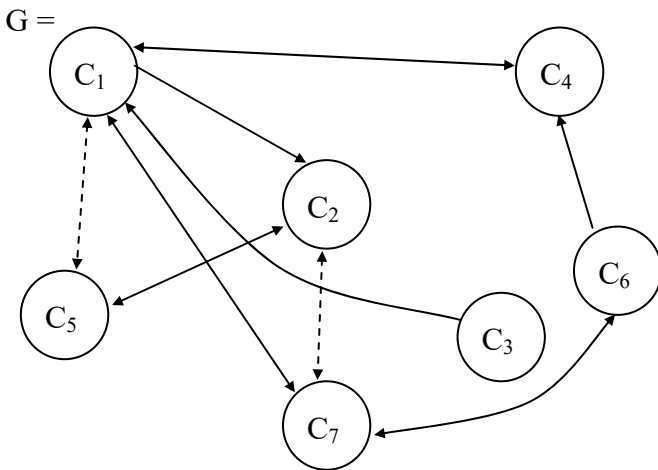

- (i) Find the most influential node and non influential node.
- (ii) Does the NCM have any powerful node associated with it?
- (iii) Find the most influential node or any powerful node if any for the associated graphs of $G \setminus C_i$, $1 \leq i \leq 7$.

11. Prove or disprove a most influential node is not the node with maximum number of edges incident to that node.

12. Study the powerful nodes of FCMs and NCMs.
13. Can one say the most powerful node is a node with the maximum number of edges incident to it?
14. Study question (13) in case of real world problem.
15. Is question (13) true in case of social networking?
16. Can you prove or disprove the fact that in networking graph does not function like the directed graphs of FCMs or NCMs?
17. Show the concept of influential node in an FCM or NCM can help the expert to analyse the problem in different angles.
18. Connect the notion of most influential node and the Kosko-Hamming distance of the same node given by two experts.
19. Prove or disprove the influential nodes of a NCMs or FCMs varies from expert to experts.
20. Prove or disprove the notion of most powerful node of an NCMs or FCMs is dependent on the experts.
21. Prove or disprove the notion of most powerful node varies from experts and experts.
22. Prove or disprove the notion of most influential node does not depend on NCM or FCMs.
23. Can merging of two FCMs affect the influential node?

24. Let $G_1 =$

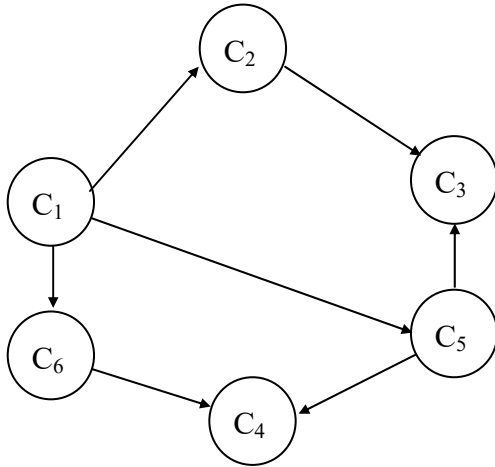

and $G_2 =$

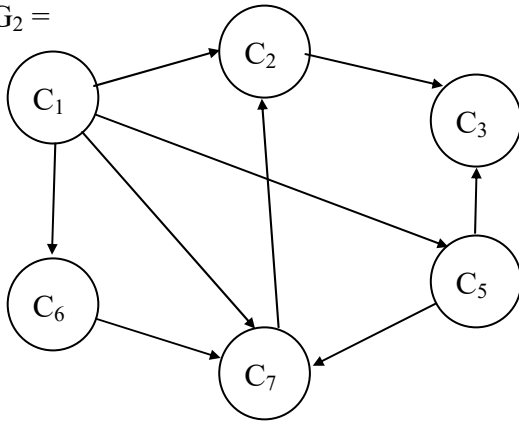

be two directed graphs of FCMs.

Now merging of G_1 with G_2 gives a graph with 7 vertices. G_1 is a graph with 6 vertices G_2 is also a graph with 7 vertices.

Now merging of G_1 with G_2 gives a graph G of 7 vertices.

- (i) Find $G \setminus \{C_7, C_6\}$, $G_1 \setminus \{C_6\}$ and $G_2 \setminus \{C_7\}$.
 - (ii) Does the merged nodes act different from usual non merged nodes?
 - (iii) Does the merged graphs act differently on powerful nodes?
25. Study the influential nodes in case of New Average FCMs and New average NCMs.
26. Can one say if G_1, G_2, \dots, G_t are directed graphs of the t-FCMs working on n nodes.
- (i) Can we say the influential nodes of the t FCMs and NAFCMs are different?
 - (ii) Can we say the powerful nodes of the t-FCMs and the NAFCMs are different?
27. Study using 5 experts a real world problem using same number of nodes.
- (i) For this find average and compare the influential nodes.
28. Can we establish that NAFCMs nodes which are most influential need not be most influential?
29. Study problem 27 in case of NANCMs.
30. Study the status of powerful node in case of NAFCMs.
31. Study the status of powerful nodes in case of NANCMs.

FURTHER READING

1. Adamopoulos, G.I., and Pappis, C.P., Some Results on the Resolution of Fuzzy Relation Equations, *Fuzzy Sets and Systems*, 60 (1993) 83-88.
2. Adams, E.S., and D.A. Farber. Beyond the Formalism Debate: Expert Reasoning, Fuzzy Logic and Complex Statutes, *Vanderbilt Law Review*, 52 (1999), 1243-1340.
<http://law.vanderbilt.edu/lawreview/vol525/adams.pdf>
3. Adlassnig, K.P., Fuzzy Set Theory in Medical Diagnosis, *IEEE Trans. Systems, Man, Cybernetics*, 16 (1986) 260-265.
4. Ashbacher, C. Introduction to Neutrosophic Logic, American Research Press, Rehoboth, 2002.
<http://www.gallup.unm.edu/~smarandache/IntrodNeutLogic.pdf>
5. Axelord, R. (ed.) Structure of Decision: The Cognitive Maps of Political Elites, Princeton Univ. Press, New Jersey, 1976.
6. Banini, G.A., and R. A. Bearman. Application of Fuzzy Cognitive Maps to Factors Affecting Slurry Rheology, *Int. J. of Mineral Processing*, 52 (1998) 233-244.

7. Bechtel, J.H. An Innovative Knowledge Based System using Fuzzy Cognitive Maps for Command and Control, Storming Media, Nov 1997. <http://www.stormingmedia.us/cgi-bin/32/3271/A327183.php>
8. Birkhoff, G., Lattice Theory, American Mathematical Society, 1979.
9. Blanco, A., Delgado, M., and Requena, I., Solving Fuzzy Relational Equations by Max-min Neural Network, Proc. 3rd IEEE Internet Conf. On Fuzzy Systems, Orlando (1994) 1737-1742.
10. Brannback, M., L. Alback, T. Finne and R. Rantanen. Cognitive Maps: An Attempt to Trace Mind and Attention in Decision Making, in C. Carlsson ed. Cognitive Maps and Strategic Thinking, Meddelanden Fran Ekonomisk Statsvetenskapliga Fakulteten vid Abo Akademi Ser. A 442 (1995) 5-25.
11. Brubaker, D. Fuzzy Cognitive Maps, EDN ACCESS, 11 April 1996. <http://www.e-insite.net/ednmag/archives/1996/041196/08column.htm>
12. Brubaker, D. More on Fuzzy Cognitive Maps, EDN ACCESS, 25 April 1996. <http://www.e-insite.net/ednmag/archives/1996/042596/09column.htm>
13. Caudill, M. Using Neural Nets: Fuzzy Cognitive Maps, Artificial Intelligence Expert, 6 (1990) 49-53.
14. Cechiarova, K., Unique Solvability of Max-Min Fuzzy Equations and Strong Regularity of Matrices over Fuzzy Algebra, Fuzzy Sets and Systems, 75 (1995) 165-177.
15. Cheng, L., and Peng, B., The Fuzzy Relation Equation with Union or Intersection Preserving Operator, Fuzzy Sets and Systems, 25 (1988) 191-204.

16. Chung, F., and Lee, T., A New Look at Solving a System of Fuzzy Relational Equations, *Fuzzy Sets and Systems*, 99 (1997) 343-353.
17. Craiger, J.P. Causal Structure, Model Inferences and Fuzzy Cognitive Maps: Help for the Behavioral Scientist, International Neural Network Society, Annual Meeting World Congress Neural Networks, June 1994.
18. Craiger, J.P., and M.D. Covert. Modeling Dynamic Social and Psychological Processes with Fuzzy Cognitive Maps. In *Proc. of the 3rd IEEE Conference on Fuzzy Systems*, 3 (1994) 1873-1877.
19. Craiger, J.P., R.J. Weiss, D.F. Goodman, and A.A. Butler. Simulating Organizational Behaviour with Fuzzy Cognitive Maps, *Int. J. of Computational Intelligence and Organization*, 1 (1996) 120-123.
20. Di Nola, A., and Sessa, S., On the Set of Composite Fuzzy Relation Equations, *Fuzzy Sets and Systems*, 9 (1983) 275-285.
21. Di Nola, A., On Solving Relational Equations in Brouwerian Lattices, *Fuzzy Sets and Systems*, 34 (1994) 365-376.
22. Di Nola, A., Pedrycz, W., and Sessa, S., Some Theoretical Aspects of Fuzzy Relation Equations Describing Fuzzy System, *Inform Sci.*, 34 (1984) 261-264.
23. Di Nola, A., Pedrycz, W., Sessa, S., and Sanchez, E., Fuzzy Relation Equations Theory as a Basis of Fuzzy Modeling: An Overview, *Fuzzy Sets and Systems*, 40 (1991) 415-429.
24. Di Nola, A., Relational Equations in Totally Ordered Lattices and their Complete Resolution, *J. Math. Appl.*, 107 (1985) 148-155.

25. Di Nola, A., Sessa, S., Pedrycz, W., and Sanchez, E., *Fuzzy Relational Equations and their Application in Knowledge Engineering*, Kluwer Academic Publishers, Dordrecht, 1989.
26. Dickerson, J.A., and B. Kosko. *Virtual Worlds as Fuzzy Cognitive Maps*, *Presence*, 3 (1994) 173-189.
27. Dickerson, J.A., Z. Cox, E.S. Wurtele and A.W. Fulmer. *Creating Metabolic and Regulatory Network Models using Fuzzy Cognitive Maps*.
<http://www.botany.iastate.edu/~mash/metnetex/NAFIPS01v3a.pdf>
28. Drewniak, J., *Equations in Classes of Fuzzy Relations*, *Fuzzy Sets and Systems*, 75 (1995) 215-228.
29. Fang, S.C., and Li, G., *Solving Fuzzy Relation Equations with a Linear Objective Function*, *Fuzzy Sets and Systems*, 103 (1999) 107-113.
30. *Fuzzy Thought Amplifier. The Fuzzy Cognitive Map Program*, Fuzzy Systems Engineering, USA.
<http://www.fuzzysys.com/ftaprod.html>
31. Gavalec, M., *Solvability and Unique Solvability of Max-min Fuzzy Equations*. *Fuzzy Sets and Systems*, 124 (2001) 385-393.
32. Gottwald, S., *Approximate Solutions of Fuzzy Relational Equations and a Characterization of t-norms that Define Matrices for Fuzzy Sets*, *Fuzzy Sets and Systems*, 75 (1995) 189-201.
33. Gottwald, S., *Approximately Solving Fuzzy Relation Equations: Some Mathematical Results and Some Heuristic Proposals*, *Fuzzy Sets and Systems*, 66 (1994) 175-193.

34. Guo, S.Z., Wang, P.Z., Di Nola, A., and Sessa, S., Further Contributions to the Study of Finite Fuzzy Relation Equations, *Fuzzy Sets and Systems*, 26 (1988) 93-104.
35. Hafner, V.V. Cognitive Maps for Navigation in Open Environments,
<http://citeseer.nj.nec.com/hafner00cognitive.html>
36. Hagiwara, M. Extended Fuzzy Cognitive Maps, *Proc. IEEE International Conference on Fuzzy Systems*, (1992) 795-801.
37. Harary, F. *Graph Theory*, Narosa Publications (reprint, Indian edition), New Delhi, 1969.
38. Hirota, K., and Pedrycz, W., Specificity Shift in Solving Fuzzy Relational Equations, *Fuzzy Sets and Systems*, 106 (1999) 211-220.
39. Kardaras, D., and B. Karakostas. The Use of Fuzzy Cognitive maps to Stimulate the Information Systems Strategic Planning Process, *Information and Software Technology*, 41 (1999) 197-210.
40. Kardaras, D., and G. Mentzas. Using fuzzy cognitive maps to model and analyze business performance assessment, In *Prof. of Int. Conf. on Advances in Industrial Engineering – Applications and Practice II*, Jacob Chen and Anil Milal (eds.), (1997) 63-68.
41. Khan, M.S., M. Quaddus, A. Intrapairot, and A. Chong, Modelling Data Warehouse Diffusion using Fuzzy Cognitive Maps – A Comparison with the System Dynamics Approach.
<http://wawisr01.uwa.edu.au/2000/Track%204/gModelling.PDF>
42. Kim, H.S., and K. C. Lee. Fuzzy Implications of Fuzzy Cognitive Maps with Emphasis on Fuzzy Causal Relations

- and Fuzzy Partially Causal Relationship, *Fuzzy Sets and Systems*, 97 (1998) 303-313.
43. Klir, G.J., and Yuan, B., *Fuzzy Sets and Fuzzy Logic: Theory and Applications*, Prentice-Hall, Englewood Cliffs NJ, 1995.
 44. Kosko, B. *Fuzzy Cognitive Maps*, *Int. J. of Man-Machine Studies*, 24 (1986) 65-75.
 45. Kosko, B., *Neural Networks and Fuzzy Systems: A Dynamical Systems Approach to Machine Intelligence*, Prentice Hall of India, 1997.
 46. Kurano, M., Yasuda, M., Nakatami, J., and Yoshida, Y., *A Fuzzy Relational Equation in Dynamic Fuzzy Systems*, *Fuzzy Sets and Systems*, 101 (1999) 439-443.
 47. Lee, K.C., J.S. Kim, N.H. Chang and S.J. Kwon. *Fuzzy Cognitive Map Approach to Web-mining Inference Amplification*, *Expert Systems with Applications*, 22 (2002) 197-211.
 48. Lee, K.C., W.J. Lee, O.B. Kwon, J.H. Han, P.I. Yu. *A Strategic Planning Simulation Based on Fuzzy Cognitive Map Knowledge and Differential Game*, *Simulation*, 71 (1998) 316-327.
 49. Lettieri, A., and Liguori, F., *Characterization of Some Fuzzy Relation Equations Provided with one Solution on a Finite Set*, *Fuzzy Sets and Systems*, 13 (1984) 83-94.
 50. Liu, F., and F. Smarandache. *Intentionally and Unintentionally. On Both, A and Non-A, in Neutrosophy.*
<http://lanl.arxiv.org/ftp/math/papers/0201/0201009.pdf>
 51. Liu, F., and F. Smarandache. *Logic: A Misleading Concept. A Contradiction Study toward Agent's Logic*, in *Proceedings of the First International Conference on Neutrosophy, Neutrosophic Logic, Neutrosophic Set,*

Neutrosophic Probability and Statistics, Florentin Smarandache editor, Xiquan, Phoenix, ISBN: 1-931233-55-1, 147 p., 2002, also published in "Libertas Mathematica", University of Texas at Arlington, 22 (2002) 175-187.
<http://lanl.arxiv.org/ftp/math/papers/0211/0211465.pdf>

52. Liu, F., and Smarandache, F., Intentionally and Unintentionally. On Both, A and Non-A, in Neutrosophy. <http://lanl.arxiv.org/ftp/math/papers/0201/0201009.pdf>
53. Loetamonphing, J., and Fang, S.C., Optimization of Fuzzy Relation Equations with Max-product Composition, Fuzzy Sets and Systems, 118 (2001) 509-517.
54. Luo, C.Z., Reachable Solution Set of a Fuzzy Relation Equation, J. of Math. Anal. Appl., 103 (1984) 524-532.
55. Luoh, L., Wang, W.J., Liaw, Y.K., New Algorithms for Solving Fuzzy Relation Equations, Mathematics and Computers in Simulation, 59 (2002) 329-333.
56. Pedrycz, W., Inverse Problem in Fuzzy Relational Equations, Fuzzy Sets and Systems, 36 (1990) 277-291.
57. Pedrycz, W., Processing in Relational Structures: Fuzzy Relational Equations, Fuzzy Sets and Systems, 25 (1991) 77-106.
58. Pelaez, C.E., and J.B. Bowles. Using Fuzzy Cognitive Maps as a System Model for Failure Modes and Effects Analysis, Information Sciences, 88 (1996) 177-199.
59. Praseetha, V.R. A New Class of Fuzzy Relation Equation and its Application to a Transportation Problem, Masters Dissertation, Guide: Dr. W. B. Vasantha Kandasamy, Department of Mathematics, Indian Institute of Technology, April 2000.
60. Praseetha, V.R., A New Class of Fuzzy Relation Equation and its Application to a Transportation Problem, Masters

- Dissertation, Guide: Dr. W. B. Vasantha Kandasamy, Department of Mathematics, Indian Institute of Technology, April 2000.
61. Ram Kishore, M. Symptom disease model in children, Masters Dissertation, Guide: Dr. W. B. Vasantha Kandasamy, Department of Mathematics, Indian Institute of Technology, Chennai, April 1999.
 62. Ramathilagam, S. Mathematical Approach to the Cement Industry problems using Fuzzy Theory, Ph.D. Dissertation, Guide: Dr. W. B. Vasantha Kandasamy, Department of Mathematics, Indian Institute of Technology, Madras, November 2002.
 63. Ramathilagam, S., Mathematical Approach to the Cement Industry problems using Fuzzy Theory, Ph.D. Dissertation, Guide: Dr. W. B. Vasantha Kandasamy, Department of Mathematics, Indian Institute of Technology, Madras, November 2002.
 64. Silva, P.C. Fuzzy Cognitive Maps over Possible Worlds, Proc. of the 1995 IEEE International Conference on Fuzzy Systems, 2 (1995) 555-560.
 65. Siraj, A., S.M. Bridges, and R.B. Vaughn. Fuzzy cognitive maps for decision support in an intelligent intrusion detection systems, www.cs.msstate.edu/~bridges/papers/nafips2001.pdf
 66. Smarandache, F. (editor), Proceedings of the First International Conference on Neutrosophy, Neutrosophic Set, Neutrosophic Probability and Statistics, Univ. of New Mexico – Gallup, 2001. <http://www.gallup.unm.edu/~smarandache/NeutrosophicProceedings.pdf>
 67. Smarandache, F. A Unifying Field in Logics: Neutrosophic Logic, Preface by Charles Le, American Research Press, Rehoboth, 1999, 2000. Second edition of the Proceedings of

the First International Conference on Neutrosophy, Neutrosophic Logic, Neutrosophic Set, Neutrosophic Probability and Statistics, University of New Mexico, Gallup, 1-3 December 2001.
<http://www.gallup.unm.edu/~smarandache/eBook-Neutrosophics2.pdf>

68. Smarandache, F. Collected Papers III, Editura Abaddaba, Oradea, 2000.
<http://www.gallup.unm.edu/~smarandache/CP3.pdf>
69. Smarandache, F. Neutrosophic Logic - Generalization of the Intuitionistic Fuzzy Logic, To be presented at the Special Session on Intuitionistic Fuzzy Sets and Related Concepts, of International EUSFLAT Conference, Zittau, Germany, 10-12 September 2003.
<http://lanl.arxiv.org/ftp/math/papers/0303/0303009.pdf>
70. Styblinski, M.A., and B.D. Meyer. Fuzzy Cognitive Maps, Signal Flow Graphs, and Qualitative Circuit Analysis, in Proc. of the 2nd IEEE International Conference on Neural Networks (ICNN – 87), San Diego, California (1988) 549-556.
71. Styblinski, M.A., and B.D. Meyer. Signal Flow Graphs versus Fuzzy Cognitive Maps in Applications to Qualitative Circuit Analysis, Int. J. of Man-machine Studies, 18 (1991) 175-186.
72. Stylios, C.D., and P.P. Groumpos. Fuzzy Cognitive Maps: a Soft Computing Technique for Intelligent Control, in Proc. of the 2000 IEEE International Symposium on Intelligent Control held in Patras, Greece, July 2000, 97-102.
73. Taber W. R. Fuzzy Cognitive Maps Model Social Systems, Artificial Intelligence Expert, 9 (1994) 18-23.
74. Uma, S. Estimation of Expert Weights using Fuzzy Cognitive Maps, Masters Dissertation, Guide: Dr.

W.B.Vasantha Kandasamy, Department of Mathematics, Indian Institute of Technology, Chennai, March 1997.

75. Vasantha Kandasamy and Smarandache Florentin, Analysis of social aspects of migrant labourers living with HIV/AIDS using Fuzzy Theory and Neutrosophic Cognitive Maps, Xiquan, Phoenix, 2004.
76. Vasantha Kandasamy, W.B. and Florentin Smarandache, Introduction to n-adaptive Fuzzy Models to Analyze Public opinion in AIDS, Hexis, Arizona, 2006.
77. Vasantha Kandasamy, W.B., and A. Minor. Estimation of Production and Loss or Gain to Industries Using Matrices, Proc. of the National Conf. on Challenges of the 21st century in Mathematics and its allied topics, Feb. 3-4, 2001, Univ. of Mysore, 211-218.
78. Vasantha Kandasamy, W.B., and Balu, M. S., Use of Weighted Multi-Expert Neural Network System to Study the Indian Politics, Varahimir J. of Math. Sci., 2 (2002) 44-53.
79. Vasantha Kandasamy, W.B., and Florentin Smarandache, Fuzzy Cognitive Maps and Neutrosophic Cognitive Maps, Xiquan, Phoenix, 2003.
80. Vasantha Kandasamy, W.B., and Indra, V., Maximizing the passengers comfort in the madras transport corporation using fuzzy programming, *Progress of Mat.*, Banaras Hindu Univ., **32** (1998) 91-134.
81. Vasantha Kandasamy, W.B., and Mary John, M., Fuzzy Analysis to Study the Pollution and the Disease Caused by Hazardous Waste From Textile Industries, *Ultra Sci*, 14 (2002) 248-251.
82. Vasantha Kandasamy, W.B., and Ram Kishore, M., Symptom-Disease Model in Children using FCM, *Ultra Sci.*, 11 (1999) 318-324.

83. Vasantha Kandasamy, W.B., and Balu, M.S., Use of Weighted Multi-Expert Neural Network System to Study the Indian Politics, Sandipani Academy, 2 (2002) 44-53.
84. Vasantha Kandasamy, W.B., and Smarandache, F., Neutrosophic Lattices, 2 Neutrosophic Sets and Systems, (2014) 42-47.
85. Vasantha Kandasamy, W.B., and Pramod, P., Parent Children Model using FCM to Study Dropouts in Primary Education, Ultra Sci., 13, (2000) 174-183.
86. Vasantha Kandasamy, W.B., and Praseetha, R., New Fuzzy Relation Equations to Estimate the Peak Hours of the Day for Transport Systems, J. of Bihar Math. Soc., 20 (2000) 1-14.
87. Vasantha Kandasamy, W.B., Vasuki, R., and Thulukkanam, K., Kosko Hamming Distance in the analysis of FCMs to study the problems of locals due to dumping of solid waste in Kodungaiyur, Ultra Scientist, 26 (2014) 55-62.
88. Vasantha Kandasamy, W.B., and Uma, S., Combined Fuzzy Cognitive Map of Socio-Economic Model, Appl. Sci. Periodical, 2 (2000) 25-27.
89. Vasantha Kandasamy, W.B., and Uma, S., Fuzzy Cognitive Map of Socio-Economic Model, Appl. Sci. Periodical, 1 (1999) 129-136.
90. Vasantha Kandasamy, W.B., and Smarandache, F., Fuzzy Relational Equations and Neutrosophic Relational Equations, Hexis (Church Rock, USA), 2004.
91. Vasantha Kandasamy, W.B., Smarandache, F., and Unnisa, I., Supermodular Lattices, Educational Publisher Inc., Ohio, 2012.
92. Vasantha Kandasamy, W.B., and V. Indra. Applications of Fuzzy Cognitive Maps to Determine the Maximum Utility

- of a Route, *J. of Fuzzy Maths*, publ. by the Int. fuzzy Mat. Inst., 8 (2000) 65-77.
93. Vasantha Kandasamy, W.B., and Yasmin Sultana, *FRM to Analyse the Employee-Employer Relationship Model*, *J. Bihar Math. Soc.*, 21 (2001) 25-34.
 94. Vasantha Kandasamy, W.B., and Yasmin Sultana, *Knowledge Processing Using Fuzzy Relational Maps*, *Ultra Sci.*, 12 (2000) 242-245.
 95. Vasantha Kandasamy, W.B., Florentin Smarandache and K. Ilanthenral, *Elementary Fuzzy Matrix Theory and Fuzzy Models for Socio Scientists*, Automaton, 2007.
 96. Vasantha Kandasamy, W.B., Mary John, M., and T. Kanagamuthu. *Study of Social Interaction and Woman Empowerment Relative to HIV/AIDS*, *Maths Tiger*, 1(4) (2002) 4-7.
 97. Vasantha Kandasamy, W.B., Neelakantan, N.R., and S. Ramathilagam. *Maximize the Production of Cement Industries by the Maximum Satisfaction of Employees using Fuzzy Matrix*, *Ultra Science*, 15 (2003) 45-56.
 98. Vasantha Kandasamy, W.B., Neelakantan, N.R., and Kannan, S.R. *Replacement of Algebraic Linear Equations by Fuzzy Relation Equations in Chemical Engineering*, In *Recent trends in Mathematical Sciences*, Proc. of Int. Conf. on Recent Advances in Mathematical Sciences held at IIT Kharagpur on Dec. 20-22, 2001, published by Narosa Publishing House, (2001) 161-168.
 99. Vasantha Kandasamy, W.B., Neelakantan, N.R., and Kannan, S.R., *Operability Study on Decision Tables in a Chemical Plant using Hierarchical Genetic Fuzzy Control Algorithms*, *Vikram Mathematical Journal*, 19 (1999) 48-59.

100. Vasantha Kandasamy, W.B., Smarandache, F., and Ilanthenral, K., Pseudo Lattice Graphs and their Applications to Fuzzy and Neutrosophic Models, Educational Publisher Inc., Ohio, 2014.
101. Yasmin Sultana, Construction of Employee-Employee Relationship Model using Fuzzy Relational Maps, Masters Dissertation, Guide: Dr. W. B. Vasantha Kandasamy, Department of Mathematics, Indian Institute of Technology, April 2000.
102. Yen, J., Langari, R., and Zadeh, L.A., Industrial Applications of Fuzzy Logic and Intelligent Systems, IEEE Press, New York 1995.
103. Yuan, Miao and Zhi-Qiang Liu. On Causal Inference in Fuzzy Cognitive Maps, IEEE Transactions on Fuzzy Systems, 81 (2000) 107-119.
104. Zadeh, L.A., A Theory of Approximate Reasoning, Machine Intelligence, 9 (1979) 149- 194.
105. Zimmermann, H.J., Fuzzy Set Theory and its Applications, Kluwer, Boston, 1988.

INDEX

D

Directed neutrosophic graphs, 70-89

I

Influential node, 185-200

K

Kosko-Hamming distance (K-H distance), 127-140

L

Least influential node, 185-200

Less influential node, 185-200

M

Merged Fuzzy Cognitive Maps (MFCMs) model, 9-108

Merged Graphs, 9-35

Merged matrices, 16-40

Merged Neutrosophic Cognitive Maps (MNCMs) model,
9-108

Merged neutrosophic graphs, 72-95

More influential node of FCMs and NCMs, 185-200

Most influential node of FCMs and NCMs, 185-200

N

- Neutrosophic merged connection matrix, 72-89
- New Average simple FCMs (NASFCMs), 159-170
- New Average simple NCMs (NASNCMs), 159-171
- New Simple Average dynamical system, 159-170
- New simple average neutrosophic matrices, 159-170
- Non influential node, 185-200

P

- Passive node, 185-200
- Pseudo lattice graphs of type II, 9-35

V

- Vital node, 185-200

ABOUT THE AUTHORS

Dr.W.B.Vasantha Kandasamy is a Professor in the Department of Mathematics, Indian Institute of Technology Madras, Chennai. In the past decade she has guided 13 Ph.D. scholars in the different fields of non-associative algebras, algebraic coding theory, transportation theory, fuzzy groups, and applications of fuzzy theory of the problems faced in chemical industries and cement industries. She has to her credit 653 research papers. She has guided over 100 M.Sc. and M.Tech. projects. She has worked in collaboration projects with the Indian Space Research Organization and with the Tamil Nadu State AIDS Control Society. She is presently working on a research project funded by the Board of Research in Nuclear Sciences, Government of India. This is her 98th book.

On India's 60th Independence Day, Dr.Vasantha was conferred the Kalpana Chawla Award for Courage and Daring Enterprise by the State Government of Tamil Nadu in recognition of her sustained fight for social justice in the Indian Institute of Technology (IIT) Madras and for her contribution to mathematics. The award, instituted in the memory of Indian-American astronaut Kalpana Chawla who died aboard Space Shuttle Columbia, carried a cash prize of five lakh rupees (the highest prize-money for any Indian award) and a gold medal.

She can be contacted at vasanthakandasamy@gmail.com

Web Site: http://mat.iitm.ac.in/home/wbv/public_html/
or <http://www.vasantha.in>

Dr. Florentin Smarandache is a Professor of Mathematics at the University of New Mexico in USA. He published over 75 books and 200 articles and notes in mathematics, physics, philosophy, psychology, rebus, literature. In mathematics his research is in number theory, non-Euclidean geometry, synthetic geometry, algebraic structures, statistics, neutrosophic logic and set (generalizations of fuzzy logic and set respectively), neutrosophic probability (generalization of classical and imprecise probability). Also, small contributions to nuclear and particle physics, information fusion, neutrosophy (a generalization of dialectics), law of sensations and stimuli, etc. He got the 2010 Telesio-Galilei Academy of Science Gold Medal, Adjunct Professor (equivalent to Doctor Honoris Causa) of Beijing Jiaotong University in 2011, and 2011 Romanian Academy Award for Technical Science (the highest in the country). Dr. W. B. Vasantha Kandasamy and Dr. Florentin Smarandache got the 2012 New Mexico-Arizona and 2011 New Mexico Book Award for Algebraic Structures. He can be contacted at smarand@unm.edu

K. Ilanthenral is the editor of The Maths Tiger, Quarterly Journal of Maths. She can be contacted at ilanthenral@gmail.com

In this book for the first time authors have ventured to study, analyse and investigate fuzzy and neutrosophic models and the experts opinion. To make such a study, innovative techniques are defined and developed. Several important conclusions about these models can be derived using these new techniques. Open problems are suggested in this book.

US \$40.00

EN
EuropaNova

ISBN 978-1-59973-297-8



9 781599 732978 >