

University of New Mexico

## UNM Digital Repository

---

Faculty and Staff Publications

Mathematics

---

2013

### Special Type of Subset Topological Spaces

Florentin Smarandache

*University of New Mexico*, smarand@unm.edu

W.B. Vasantha Kandasamy

vasanthakandasamy@gmail.com

Follow this and additional works at: [https://digitalrepository.unm.edu/math\\_fsp](https://digitalrepository.unm.edu/math_fsp)



Part of the [Algebra Commons](#), and the [Analysis Commons](#)

---

#### Recommended Citation

W.B. Vasantha Kandasamy & F. Smarandache. Special Type of Subset Topological Spaces. Ohio: Educational Publishing, 2013.

This Book is brought to you for free and open access by the Mathematics at UNM Digital Repository. It has been accepted for inclusion in Faculty and Staff Publications by an authorized administrator of UNM Digital Repository. For more information, please contact [amywinter@unm.edu](mailto:amywinter@unm.edu), [lsloane@salud.unm.edu](mailto:lsloane@salud.unm.edu), [sarahrk@unm.edu](mailto:sarahrk@unm.edu).

The book cover features a repeating abstract pattern of overlapping, jagged, leaf-like shapes in shades of blue and white. The pattern is dense and covers the entire background. The title is centered in a white serif font against a solid blue rectangular background.

SPECIAL TYPE OF  
SUBSET TOPOLOGICAL  
SPACES

**W.B.VASANTHA KANDASAMY  
FLORENTIN SMARANDACHE**

# Special Type of Subset Topological Spaces

**W. B. Vasantha Kandasamy  
Florentin Smarandache**

**Educational Publisher Inc.  
Ohio  
2013**

This book can be ordered from:

Education Publisher Inc.  
1313 Chesapeake Ave.  
Columbus, Ohio 43212,  
USA  
Toll Free: 1-866-880-5373

Copyright 2013 by *Educational Publisher Inc.* and the *Authors*

Peer reviewers:

Marius Coman, researcher, Bucharest, Romania.  
Prof. Valeri Kroumov, Okayama University of Science, Japan.  
Said Broumi, University of Hassan II Mohammedia, Casablanca,  
Morocco.  
Dr. Stefan Vladutescu, University of Craiova, Romania.

Many books can be downloaded from the following  
Digital Library of Science:  
<http://www.gallup.unm.edu/eBooks-otherformats.htm>

**ISBN-13: 978-1-59973-243-5**  
**EAN: 9781599732435**

**Printed in the United States of America**

# CONTENTS

Preface	5
Chapter One <b>INTRODUCTION</b>	7
Chapter Two <b>SPECIAL TYPES OF SUBSET TOPOLOGICAL SPACES USING SEMIGROUPS AND GROUPS</b>	9
Chapter Three <b>SPECIAL TYPES OF SUBSET TOPOLOGICAL SPACES USING SEMIRINGS AND RINGS</b>	68
Chapter Four <b>SUBSET SET IDEAL TOPOLOGICAL SEMIRING SPACES</b>	163

<b>FURTHER READING</b>	237
<b>INDEX</b>	239
<b>ABOUT THE AUTHORS</b>	241

## PREFACE

In this book we construct special subset topological spaces using subsets from semigroups or groups or rings or semirings. Such study is carried out for the first time and it is both interesting and innovative.

Suppose  $P$  is a semigroup and  $S$  is the collection of all subsets of  $P$  together with the empty set, then  $S$  can be given three types of topologies and all the three related topological spaces are distinct and results in more types of topological spaces. When the semigroup is finite,  $S$  gives more types of finite topological spaces. The same is true in case of groups also. Several interesting properties enjoyed by them are also discussed in this book.

In case of subset semigroup using semigroup  $P$  we can have subset set ideal topological spaces built using subsemigroups. The advantage of this notion is we can have as many subset set ideal topological spaces as the number of semigroups in  $P$ . In case of subset semigroups using groups we can use the subset subsemigroups to build subset set ideal topological spaces over these subset semigroups. This is true in case of subset semigroups which are built using semigroups also.

Finally these special subset topological spaces can also be non commutative depending on the semigroup or the group.

Suppose we use the concept of semiring or a ring and build a subset semiring, we can use them to construct six distinct subset topological spaces of which three will be non commutative; if the semiring or the ring used is non commutative. This study is developed and described with examples.

We can use the notion of set ideals and build subset set ideal topological spaces over subsemirings of semirings or subrings of rings.

In this case we have the notion of orthogonal topological subspaces. We can use the subrings of a ring or subsemirings of a semiring to construct subset set ideal topological spaces of the six types. This is described and developed in this book.

We thank Dr. K.Kandasamy for proof reading and being extremely supportive.

W.B.VASANTHA KANDASAMY  
FLORENTIN SMARANDACHE



## Chapter One

# INTRODUCTION

In this book authors introduce the notion of special subset topological spaces of subsets from rings or semigroups or semirings or groups. These subset semigroups and subset semirings are given topological structures. In case of subset semigroups we can give in general three topological space structures in which two of the spaces inherit the operation from the semigroup. On these subset semirings we can have six distinct topological spaces of which five of them inherit the operations of the ring or the semiring.

The speciality about these topological spaces is at times when the basic structure used to build the subset semigroup or subset semiring is non commutative so will be the topological spaces  $T_s$ ,  $T_{\cup}^{\times}$  and  $T_{\cap}^{\times}$ . However  $T_s$  has no meaning in case of subset semigroups.

For more about these subset structures please refer [22-3].

For more about special topological spaces please refer [19-20].

These topological spaces constructed using subset semigroups and subset semirings can be of finite or infinite order. Further we can associate trees related with these spaces. Certainly these trees can find applications in several fields of technology and engineering.

The notion of non commutative topological spaces is interesting and these topological spaces have subset zero divisors also these topological spaces have distinct pairs of subspaces which annihilate each other.

These concepts are new only in case of topological spaces  $T_s$ ,  $T_{\cup}^{\times}$  and  $T_{\cap}^{\times}$ . Finally set ideal subset topological semiring spaces and set ideal subset topological semigroup spaces are constructed and several of their properties are derived. This study leads to several topological spaces depending on the subsemigroups (or subsemirings).

## Chapter Two

# SPECIAL TYPES OF SUBSET TOPOLOGICAL SPACES USING SEMIGROUPS AND GROUPS

In this chapter we build topological spaces using groups and semigroups. These pave way to give more topological spaces using the inherited operations of these basic algebraic structures. Here we study them, describe them and derive several properties associated with them.

**DEFINITION 2.1:** *Let  $S$  be a collection of all subsets of a semigroup  $(P, *)$ ;  $S$  is a subset semigroup under the operation  $*$ . We can define on  $S$  three types of topological spaces called the ordinary or usual or standard type of topological spaces of the semigroup  $P$ .*

$$\text{Let } S' = \{\emptyset\} \cup S.$$

$T_o = \{S', \cup, \cap\}$  is the ordinary or usual or standard type of topological space of a subset semigroup  $S$ .

$T_{\cup} = \{S, \cup, *\}$  and  $T_{\cap} = \{S', \cap, *\}$  will be known as the special type of topological spaces of the subset semigroup  $(S, *)$ .

It is to be noted that  $T_{\cup}$  and  $T_{\cap}$  are non commutative if the semigroup  $(P, *)$  is non commutative.

We will give examples of them.

**Example 2.1:** Let  $S = \{\text{Collection of all subsets from the semigroup } (P, *) = \{Z_{12}, \times\}\}$  be the subset semigroup.

We see  $T_0 = \{S' = S \cup \{\phi\}, \cup, \cap\}$ ,  $T_{\cap} = \{S', \cap, \times\}$  and  $T_{\cup} = \{S, \cup, \times\}$  are the three topological spaces associated with  $(P, *) = \{Z_{12}, \times\}$ .

We just take  $A = \{2, 6, 0, 7, 5\}$  and  $B = \{9, 8, 5, 3, 4\}$  in  $S$ .  
Let  $A, B \in T_0$ .

$$\begin{aligned} \text{We see } A \cup B &= \{2, 6, 0, 7, 5\} \cup \{9, 8, 5, 3, 4\} \\ &= \{0, 2, 3, 4, 5, 6, 7, 8, 9\} \end{aligned}$$

$$\begin{aligned} \text{and } A \cap B &= \{2, 6, 0, 7, 5\} \cap \{9, 8, 5, 3, 4\} \\ &= \{5\} \text{ are in } T_0. \end{aligned}$$

Consider  $A, B \in T_{\cup}$ .

$$\begin{aligned} A \cup B &= \{2, 6, 0, 7, 5\} \cup \{9, 8, 5, 3, 4\} \\ &= \{0, 2, 3, 4, 5, 7, 8, 9\} \text{ and} \end{aligned}$$

$$\begin{aligned} A \times B &= \{2, 6, 0, 7, 5\} \times \{9, 8, 5, 3, 4\} \\ &= \{6, 0, 9, 3, 8, 4, 10, 11, 1\} \text{ are in } T_{\cup}. \end{aligned}$$

We see  $T_0$  and  $T_{\cup}$  are distinctly different as topological spaces.

Now let  $A, B \in T_{\cap}$ .

$$\begin{aligned} A \times B &= \{2, 6, 0, 7, 5\} \times \{9, 8, 5, 3, 4\} \\ &= \{0, 3, 6, 9, 4, 8, 10, 11, 1\} \end{aligned}$$

$$\begin{aligned} \text{and } A \cap B &= \{2, 6, 0, 7, 5\} \cap \{9, 8, 5, 3, 4\} \\ &= \{5\} \text{ are in } T_{\cap}. \end{aligned}$$

$T_{\cap}$  is different from  $T_{\cup}$  and topological spaces.

Thus using a semigroup we can get three different types of subset topological spaces. All the three subset topological spaces of this semigroup is commutative as  $(Z_{12}, \times)$  is a commutative semigroup.

**Example 2.2:** Let  $S_1 = \{\text{Collection of all subsets from the semigroup } (P, *) = \{Z_{11}, \times\}\}$  be the subset semigroup.

We have three subset semigroup topological spaces associated with  $S_1$ .

$$\text{Take } A = \{0, 5, 3, 4\} \text{ and } B = \{1, 7, 9, 10\} \in S_1.$$

$$\text{Let } A, B \in T_o = \{S'_1 = S \cup \{\phi\}, \cup, \cap\};$$

$$\begin{aligned} A \cup B &= \{0, 5, 3, 4\} \cup \{1, 7, 9, 10\} \\ &= \{0, 5, 3, 4, 1, 7, 9, 10\} \end{aligned}$$

$$\begin{aligned} \text{and } A \cap B &= \{0, 5, 3, 4\} \cap \{1, 7, 9, 10\} \\ &= \phi \text{ are in } T_o, \end{aligned}$$

the ordinary subset topological semigroup space of  $S_1$ .

$$\text{Let } A, B \in T_{\cup};$$

$$\begin{aligned} A \cup B &= \{0, 5, 3, 4\} \cup \{1, 7, 9, 10\} \\ &= \{0, 5, 3, 4, 1, 7, 9, 10\} \text{ and} \end{aligned}$$

$$\begin{aligned} A \times B &= \{0, 5, 3, 4\} \times \{1, 7, 9, 10\} \\ &= \{0, 5, 3, 4, 2, 10, 6, 1, 8, 7\} \text{ are in } T_{\cup}. \end{aligned}$$

$T_{\cup}$  is a different subset topological semigroup space from  $T_o$ .

Let  $A, B \in T_{\cap}$ ;

$$\begin{aligned} A \cap B &= \{0, 5, 3, 4\} \cap \{1, 7, 9, 10\} \\ &= \{\emptyset\} \text{ and} \end{aligned}$$

$$\begin{aligned} A \cup B &= \{0, 5, 3, 4\} \cup \{1, 7, 9, 10\} \\ &= \{0, 5, 3, 4, 1, 7, 9, 10\} \text{ are in } T_{\cap}. \end{aligned}$$

$T_{\cap}$  is a different subset topological semigroup spaces from  $T_{\cup}$  and  $T_{\circ}$ .

All the three spaces are commutative.

However it is pertinent to keep on record the subset semigroup topological spaces given in example 2.1 and 2.2 are different.

For we see in the subset semigroup  $S$  of example 2.1 we can have for  $A, B \in S \setminus \{0\}$ .  $A \times B = \{0\}$  and this is not possible in the subset semigroup  $S_1$  of example 2.2.

For any  $A, B \in S_1 \setminus \{0\}$   
 $A \times B \neq \{0\}$ .

Consider  $A = \{4, 8, 0\}$  and  $B = \{0, 3, 9, 6\} \in S \setminus \{0\}$  in example 2.1,  $A \times B = \{4, 8, 0\} \times \{0, 3, 9, 6\} = \{0\}$ .

This is not possible in  $S_1$  given in example 2.2.

Inview of this we define the notion of subset topological zero divisors in  $T_{\cup}$  and  $T_{\cap}$ .

However both the subset topological spaces  $T_{\cup}$  and  $T_{\cap}$  can have subset topological zero divisors in  $T_{\cup}$  and  $T_{\cap}$ .  $T_{\circ}$  is free from subset topological zero divisors.

**DEFINITION 2.2:** *Let*

$S = \{\text{Collection of all subsets from the semigroup } (P, *)\}$  be the subset semigroup.  $T_{\cup}$ ,  $T_{\cap}$  and  $T_0$  be the subset semigroup topological spaces of  $S$ .  $T_{\cup}$  and  $T_{\cap}$  is said to have subset topological zero divisors if for  $A, B \in S \setminus \{0\}$ ;  $A * B = \{0\}$ .

**Example 2.3:** Let  $S_3 = \{\text{Collection of all subsets from the semigroup } P = \{C(Z_{16}), \times\}\}$  be the subset semigroup of  $P$ .  $S_3$  has subset topological zero divisors.

For take  $A = \{8i_F, 8, 4i_F, 12i_F\}$  and  $B = \{4i_F, 8i_F, 4, 0\} \in S_3$ .

$$\begin{aligned} A \times B &= \{8i_F, 8, 4i_F, 12i_F\} \times \{0, 4, 4i_F, 8i_F\} \\ &= \{0\}. \end{aligned}$$

Hence the claim.

Take  $A = \{4i_F, 4\} \in S_3$ .

$$A \times B = \{4i_F, 4\} \times \{4i_F, 4\} = \{0\}.$$

**Example 2.4:** Let  $S_4 = \{\text{Collection of all subsets from the semigroup } P = \{Z_6 \times Z_{10}, \times\}\}$  be the subset semigroup.  $T_{\cup}$  and  $T_{\cap}$  the subset semigroup topological spaces of  $S_4$  has subset topological zero divisors.

Take  $A = \{(3, 5), (0, 0), (3, 0), (0, 5)\}$  and  
 $B = \{(2, 2), (4, 0), (0, 4), (2, 4), (4, 2), (2, 0), (4, 0)\} \in S_4$ .

$$\begin{aligned} \text{Clearly } A \times B &= \{(3, 5), (0, 0), (3, 0), (0, 5)\} \times \{(2, 2), \\ &\quad (4, 0), (0, 4), (2, 4), (4, 2), (2, 0), (4, 0)\} \\ &= \{(0, 0)\}. \end{aligned}$$

Let  $M_1 = \{\text{Collection of all subsets from the subsemigroup } Z_6 \times \{0\}\}$  be the subset subsemigroup of  $S_4$  and  
 $M_2 = \{\text{Collection of all subsets from the subsemigroup } \{0\} \times Z_{10}\}$  be the subset subsemigroup of  $S_4$ .

$M_1$  and  $M_2$  be subset subsemigroups; we can have subset subsemigroup topological subspaces of  $M_1$  and  $M_2$ .

Further  $M_1 \times M_2 = \{(0, 0)\}$ , we define these topological subspaces as orthogonal subset topological subspaces of  $S$ .

Let  $N_1 = \{\text{Collection of all subsets from the subsemigroup } (\{0, 3\} \times \{0, 5\})\}$  be the subset subsemigroup.

Now we can build the three types of subset topological subsemigroup subspaces  $T_o^{M_1}, T_o^{M_2}, T_o^{N_1}, T_\cup^{M_1}, T_\cup^{M_2}, T_\cup^{N_1}, T_\cap^{M_1}, T_\cap^{M_2}$  and  $T_\cap^{N_1}$ ; all the three subspaces are distinct and are of finite order.

We also have trees associated with them; these trees will be subtrees of the trees associated with the subset topological semigroup spaces  $T_o, T_\cup$  and  $T_\cap$  respectively.

**Example 2.5:** Let

$S = \{\text{Collection of all subsets from the semigroup } P = (Z_{24}, \times)\}$  be the subset semigroup.  $T_o = \{S' = S \cup \{\phi\}, \cup, \cap\}$ ,  $T_\cup = \{S, \cup, \times\}$  and  $T_\cap = \{S', \cap, \times\}$  are the subset semigroup topological spaces of  $S$ .

We see  $A = \{0, 12, 6, 18\}$  and  $B = \{4, 0, 8, 12, 16\} \in S$ .

$$\begin{aligned} A \times B &= \{0, 12, 6, 18\} \times \{4, 0, 8, 12, 16\} \\ &= \{0\}, \end{aligned}$$

hence  $T_\cup$  and  $T_\cap$  has subset topological zero divisors.

We say the subset topological semigroup spaces has subset zero divisors.

All the five examples which we have seen are finite and are commutative.

We now proceed onto give examples of subset semigroup topological spaces which has infinite cardinality.



**Example 2.6:** Let

$S = \{\text{Collection of all subsets from the semigroup } (Z, \times)\}$  be the subset semigroup.  $T_o$ ,  $T_\cup$  and  $T_\cap$  be the subset topological semigroup spaces of  $S$ .

All the three spaces are of infinite order.

Take  $A = \{-5, 6, 8, -12, 7\}$  and  $B = \{0, -1, 5, 2, -3, 15\} \in T_o = \{S \cup \{\phi\}, \cup, \cap\}$ .

We see  $A \cup B = \{-5, 6, 8, -12, 7\} \cup \{0, -1, 5, 2, -3, 15\}$   
 $= \{0, -1, 2, -3, 15, 5, -5, 6, 8, -12, 7\}$

and  $A \cap B = \{-5, 6, 8, -12, 7\} \cap \{0, -1, 5, 2, -3, 15\}$   
 $= \{0\}$  are in  $T_o$ .

$T_o$  is a commutative subset semigroup topological space of infinite order and has no subset topological zero divisors.

Let  $A, B \in T_\cup = \{S, \cup, \times\}$

$A \cup B = \{-5, 6, 8, -12, 7\} \cup \{0, -1, 5, 2, -3, 15\}$   
 $= \{-5, 6, 8, -12, 7, 0, -1, 5, 2, -3, 15\}$  and

$A \times B = \{-5, 6, 8, -12, 7\} \times \{0, -1, 5, 2, -3, 15\}$   
 $= \{0, 5, -6, -8, 12, -7, -25, 30, 40, -60, 35, -10,$   
 $16, -24, 14, 15, -18, -24, 36, -21, -75, 90, 120,$   
 $-180, 105\} \in T_\cup$ .

It is easily verified that  $T_\cup$  is a subset semigroup topological space which is commutative and of infinite order.  $T_\cup$  has no subset topological zero divisors.

Let  $A, B \in T_\cap$  where

$A \cap B = \{-5, 6, 8, -12, 7\} \cap \{0, -1, 5, 2, -3, 15\}$   
 $= \{\phi\}$  and

$$\begin{aligned} A \times B &= \{-5, 6, 8, -12, 7\} \times \{0, -1, 5, 2, -3, 15\} \\ &= \{0, 5, -6, -8, 12, -7, -25, 30, 40, -60, 35, -10, \\ &\quad 16, -24, 14, -18, 15, -24, 36, -21, -75, 90, 120, \\ &\quad -180, 105\} \end{aligned}$$

are in  $T_{\cap}$ .  $T_{\cap}$  has no subset semigroup topological zero divisors.

**Example 2.7:** Let  $S = \{\text{Collection of all subsets from the semigroup } \{\mathbb{R}^+ \cup \{0\}, +\}\}$  be the subset semigroup.  $T_{\cup} = S' = S \cup \{\emptyset, \cup, \cap\}$ ,  $T_{\cup} = \{S, \cup, +\}$  and  $T_{\cap} = \{S', \cap, +\}$  are the three subset semigroup topological spaces associated with  $S'$  (or  $S$ ).

All the three spaces are of infinite order and has no subset semigroup topological zero divisors.

Let  $A = \{3, \sqrt{7}, \sqrt{5}, 10 + \sqrt{3}, 8/3\}$   
and  $B = \{0, 1, 5/\sqrt{7}, 3 + \sqrt{2}, 5/7\} \in T_{\cup}$ .

$$\begin{aligned} A \cup B &= \{3, \sqrt{7}, \sqrt{5}, 10 + \sqrt{3}, 8/3\} \cup \{0, 1, 5/\sqrt{7}, \\ &\quad 3 + \sqrt{2}, 5/7\} \\ &= \{3, \sqrt{5}, \sqrt{7}, 10 + \sqrt{3}, 8/3, 0, 1, 5/\sqrt{7}, \\ &\quad 3 + \sqrt{2}, 5/7\} \text{ and} \end{aligned}$$

$$\begin{aligned} A \cap B &= \{3, \sqrt{7}, \sqrt{5}, 10 + \sqrt{3}, 8/3\} \cap \{0, 1, 5/\sqrt{7}, \\ &\quad 3 + \sqrt{2}, 5/7\} \\ &= \{\emptyset\} \text{ are in } T_{\cap}. \end{aligned}$$

$T_{\cup}$  is a commutative subset topological semigroup space of infinite order.

Infact whatever be the structure of the semigroup over which the subset semigroup topological space  $T_{\cup}$  is built,  $T_{\cup}$  will always a commutative subset semigroup topological space of  $S$ .

Now for the same S we find for  $A, B \in T_{\cup} = \{S, \cup, +\}$  the union and sum

$$\begin{aligned} A \cup B &= \{3, \sqrt{7}, \sqrt{5}, 10 + \sqrt{3}, 8/3\} \cup \{0, 1, 5/\sqrt{7}, \\ &\quad 3 + \sqrt{2}, 5/7\} \\ &= \{3, \sqrt{7}, \sqrt{5}, 10 + \sqrt{3}, 8/3, 0, 1, 5/\sqrt{7}, 3 + \sqrt{2}, \\ &\quad 5/7\} \text{ and} \end{aligned}$$

$$\begin{aligned} A + B &= \{3, \sqrt{7}, \sqrt{5}, 10 + \sqrt{3}, 8/3\} + \{0, 1, 5/\sqrt{7}, \\ &\quad 3 + \sqrt{2}, 5/7\} \\ &= \{3, \sqrt{7}, \sqrt{5}, 10 + \sqrt{3}, 8/3, 4, 1 + \sqrt{7}, 1 + \sqrt{5}, \\ &\quad 11 + \sqrt{3}, 11/3, 3 + 5/\sqrt{7}, \sqrt{7} + 5/\sqrt{7}, \\ &\quad \sqrt{5} + 5/\sqrt{7}, 10 + \sqrt{3} + 5/\sqrt{7}, 8/3 + 5/\sqrt{7}, \\ &\quad 6 + \sqrt{2}, 3 + \sqrt{7} + \sqrt{2}, 3 + \sqrt{2} + \sqrt{5}, 13 + \sqrt{3} + \\ &\quad \sqrt{2}, 8/3 + 3 + \sqrt{2}, 3 + 5/7, \sqrt{7} + 5/7, \sqrt{5} + 5/7, \\ &\quad 10 + \sqrt{3} + 5/7, 8/3 + 5/7\} \in T_{\cup}. \end{aligned}$$

$T_{\cup}$  is of infinite order commutative subset semigroup topological space and does not contain subset semigroup topological zero divisors.

Let  $A, B \in T_{\cap} = \{S', \cap, +\}$

$$\begin{aligned} A \cap B &= \{3, \sqrt{7}, \sqrt{5}, 10 + \sqrt{3}, 8/3\} \cap \{0, 1, 5/\sqrt{7}, \\ &\quad 3 + \sqrt{2}, 5/7\} \\ &= \phi \text{ is in } T_{\cap}. \end{aligned}$$

$$\begin{aligned} A + B &= \{3, \sqrt{7}, \sqrt{5}, 10 + \sqrt{3}, 8/3\} + \{0, 1, 5/\sqrt{7}, \\ &\quad 3 + \sqrt{2}, 5/7\} \end{aligned}$$

$$\begin{aligned}
 = & \{3, \sqrt{7}, \sqrt{5}, 10 + \sqrt{3}, 8/3, 4, 1 + \sqrt{7}, \\
 & 1 + \sqrt{5}, 11 + \sqrt{3}, 11/3, 5/\sqrt{7} + 3, 5/\sqrt{7} + \\
 & \sqrt{7}, 5/\sqrt{7} + \sqrt{5}, 10 + \sqrt{3} + 5/\sqrt{7}, \\
 & 8/3 + 5/\sqrt{7}, 6 + \sqrt{2}, 3 + \sqrt{7} + \sqrt{2}, 3 + \\
 & \sqrt{2} + \sqrt{7}, 13 + \sqrt{3} + \sqrt{2}, 8/3 + 3 + \sqrt{2}, \\
 & 5/7 + 3, \sqrt{7} + 5/7, \sqrt{5} + 5/7, 10 + 5/7 + \sqrt{3}, \\
 & 8/3 + 5/7\} \text{ are in } T_{\cap}.
 \end{aligned}$$

We see  $T_{\cap}$  has no subset topological zero divisors but is non commutative and is of infinite order.

**Example 2.8:** Let  $S = \{\text{Collection of all subsets from the semigroup } P = \langle \langle Z \cup I \rangle, \times \rangle\}$  be the subset semigroup.  $T_{\circ}$ ,  $T_{\cap}$  and  $T_{\cup}$  be the subset semigroup topological spaces of  $S$  which will also be known as neutrosophic subset semigroup topological spaces.

We see  $T_{\cup}$  and  $T_{\cap}$  has infinite number of zero divisors.

For take

$$A = \{I - 1, 3I - 3, 9I - 9, 10 - 10I, 6 - 6I, 12 - 12I\} \text{ and}$$

$$B = \{8I, 0, 9I, 15I, 112I\} \in T_{\cup} \text{ (or } T_{\cap}).$$

$$\begin{aligned}
 A \times B &= \{I - 1, 3I - 3, 9I - 9, 10 - 10I, 6 - 6I, 12 - 12I\} \\
 &\quad \times \{8I, 0, 9I, 15I, 112I\} \\
 &= \{0\}.
 \end{aligned}$$

Thus  $T_{\cup}$  and  $T_{\cap}$  have infinite number of subset semigroup topological zero divisors.

However if  $\langle Z \cup I \rangle$  in the above example is replaced by  $\langle Z^+ \cup \{0\} \cup I \rangle$ ;  $T_{\circ}$ ,  $T_{\cup}$  and  $T_{\cap}$  will continue to be a subset semigroup topological space but  $T_{\cup}$  and  $T_{\cap}$  will not have subset semigroup topological zero divisors.

**Example 2.9:** Let  $S = \{\text{Collection of all subsets from the semigroup}\}$

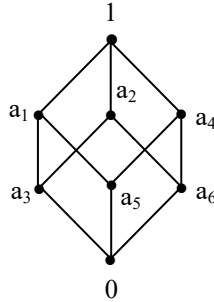

under the union operation '+' so  $a_1 \cup a_3 = a_1 + a_3 = a_1$  be the subset semigroup.  $T_0$ ,  $T_\cup$  and  $T_\cap$  are subset semigroup topological space of the subset semigroup  $S$ .

Let  $A = \{a_1, a_3, a_4\}$  and  
 $B = \{0, a_6, a_2, a_1\} \in T_0 = \{S' = S \cup \{\phi\}, \cup, \cap\}$ .

$$A \cup B = \{a_1, a_3, a_4\} \cup \{0, a_6, a_2, a_1\}$$

$$= \{0, a_1, a_2, a_6, a_4, a_3\} \text{ and}$$

$$A \cap B = \{a_1, a_3, a_4\} \cap \{0, a_6, a_2, a_1\}$$

$$= \{a_1\} \text{ are in } T_0.$$

$$A, B \in T_\cup,$$

$$A \cup B = \{a_1, a_3, a_4\} \cup \{0, a_6, a_2, a_1\}$$

$$= \{a_1, a_3, a_4, 0, a_6, a_2\}$$

and

$$A + B = \{a_1, a_3, a_4\} + \{0, a_6, a_2, a_1\}$$

$$= \{a_1, 1, a_3, a_4, a_2\}$$

are in  $T_\cup$  and  $T_0$  is distinctly different as subset semigroup topological space from  $T_\cup$ .

$$\text{Let } A, B \in T_\cap,$$

$$A + B = \{a_1, a_3, a_4\} + \{0, a_6, a_2, a_1\}$$

$$= \{1, a_1, a_3, a_2, a_4\} \text{ and}$$

$$\begin{aligned} A \cap B &= \{a_1, a_3, a_4\} \cap \{0, a_6, a_2, a_1\} \\ &= \{a_1\} \text{ are in } T_{\cap}. \end{aligned}$$

$T_{\cap}$  is different from  $T_{\cup}$  and  $T_{\circ}$ .

Thus we get three different subset semigroup topological spaces all are of finite order and commutative. However  $T_{\cup}$  and  $T_{\cap}$  has no non trivial subset semigroup topological zero divisors.

Suppose in the above example ‘+’ that is ‘ $\cup$ ’ is replaced by  $\times$  that is  $\cap$  we see for the same  $A, B \in T_{\cup}$  or  $A, B \in T_{\cap}$  we see

$$\begin{aligned} A \times B &= \{a_1, a_3, a_4\} \times \{0, a_6, a_2, a_1\} \\ &= \{0, a_6, a_3, a_1\} \in T_{\cap} \text{ (or } T_{\cup}). \end{aligned}$$

We see  $T_{\cup}$  and  $T_{\cap}$  have subset semigroup topological zero divisors given by;

$$\begin{aligned} A &= \{a_3, a_6\} \text{ and } B = \{a_5, 0\} \in T_{\cup} \text{ and } T_{\cap}. \\ A \times B &= \{a_3, a_6\} \times \{a_5, 0\} \\ &= \{0\} \end{aligned}$$

is a subset semigroup topological zero divisor of  $T_{\cup}$  and  $T_{\cap}$ .

**Example 2.10:** Let  $S = \{\text{Collection of all subsets from the semigroup } Z_6(g) \text{ where } g^2 = 0 \text{ under ‘}\times\text{’}\}$  be the subset semigroup.

Let  $T_{\circ}$ ,  $T_{\cup}$  and  $T_{\cap}$  be the subset semigroup topological spaces of  $S$ .

Clearly  $T_{\cup}$  and  $T_{\cap}$  has subset topological zero divisors for take  $A = \{3g, 3, 0, g\}$  and  $B = \{2g, 4g, 0\} \in T_{\cup}$  (or  $T_{\cap}$ ). We see  $A \times B = \{3g, 3, 0, g\} \times \{2g, 4g, 0\} = \{0\}$ .

Inview of all these examples we put forth the following theorem.

**THEOREM 2.1:** *Let*

$S = \{\text{Collection of all subsets from the semigroup } (P, *)\}$  be the subset semigroup.  $T_\circ$ ,  $T_\cup$  and  $T_\cap$  be the subset semigroup topological spaces of  $S$ .  $T_\cup$  and  $T_\cap$  has subset semigroup topological zero divisors if the semigroup  $(P, *)$  has zero divisors.

The proof is direct and hence left as an exercise to the reader.

**THEOREM 2.2:** *Let*

$S = \{\text{Collection of all subsets from semigroup } (P, *)\}$  be the subset semigroup.  $T_\circ$ ,  $T_\cup$  and  $T_\cap$  be subset semigroup topological space of  $S$ . The subset semigroup topological spaces  $T_\cup$  and  $T_\cap$  have no subset semigroup topological zero divisors if  $(P, *)$  has no zero divisors.

Proof follows from the observations if  $A, B \in T_\cup$  (or  $T_\cap$ )  $A * B \neq \{0\}$  if  $A \neq \{0\}$  and  $B \neq \{0\}$ .

We now give more examples.

**Example 2.11:** Let  $S = \{\text{Collection of all subsets from the matrix semigroup; } (P, \times) = \{(a_1, a_2, a_3, a_4, a_5) \mid a_i \in \mathbb{Z}, 1 \leq i \leq 5\}\}$  be the subset semigroup.  $T_\circ$ ,  $T_\cup$  and  $T_\cap$  be the subset semigroup topological spaces of  $S$ .

$T_\cup$  and  $T_\cap$  has subset topological zero divisors. Further we have subset semigroup topological subspaces of  $T_\cup$  and  $T_\cap$  such that  $M_i \times M_j = \{0\}$ ;  $i \neq j$  where  $M_1 = \{\text{Collection of all subsets from the matrix subsemigroup } P_1 = \{(a_1, 0, 0, 0, 0) \mid a_1 \in \mathbb{Z}\} \subseteq S$ ,  $M_2 = \{\text{Collection of all subsets from the matrix subsemigroup } P_2 = \{(0, a_2, 0, 0, 0) \mid a_2 \in \mathbb{Z}\} \subseteq S$ ;  $M_3 = \{\text{Collection of all subsets from the matrix subsemigroup } P_3 = \{(0, 0, a_3, 0, 0) \mid a_3 \in \mathbb{Z}\} \subseteq S$ ;  $M_4 = \{\text{Collection of all subsets from the matrix subsemigroup } P_4 = \{(0, 0, 0, a_4, 0) \mid a_4 \in \mathbb{Z}\} \subseteq S$  and  $M_5 = \{\text{Collection of all subsets from the matrix subsemigroup } P_5 = \{(0, 0, 0, 0, a_5) \mid a_5 \in \mathbb{Z}\} \subseteq S$  are the subset subsemigroup

and we have related with these subset subsemigroups the subset subsemigroup topological subspaces  $T_{\cup}^{M_i}$  and  $T_{\cap}^{M_i}$ ;  $1 \leq i \leq 5$ . We see  $M_i \times M_j = \{0\}$ ;  $1 \leq i, j \leq 5$ .

We have other subset semigroup topological zero divisors also.

Take  $N_1 = \{\text{Collection of all subsets from the subsemigroup } P_6 = \{(a_1, a_2, 0, 0, 0) \mid a_1, a_2 \in Z\} \subseteq P\} \subseteq S$  and  $N_2 = \{\text{Collection of all subsets from the subsemigroup } P_7 = \{(0, 0, a_1, a_2, a_3) \mid a_1, a_2, a_3 \in Z\} \subseteq P\} \subseteq S$  are both subset semigroup topological subspaces of  $T_{\circ}, T_{\cup}$  and  $T_{\cap}$  such that  $N_1 \times N_2 = \{0\}$  (for  $N_1, N_2$  contained in  $T_{\cup}$  and  $T_{\cap}$ ).

**Example 2.12:** Let  $S = \{\text{Collection of all subsets from the semigroup}$

$$P = \left\{ \left[ \begin{array}{c} P_1 \\ P_2 \\ P_3 \\ P_4 \\ P_5 \\ P_6 \\ P_7 \end{array} \right] \mid p_i \in Q, 1 \leq i \leq 7 \right\}$$

be the subset semigroup  $P$  under the natural product  $\times_n$ .

$T_{\circ}, T_{\cup}$  and  $T_{\cap}$  are subset topological semigroup spaces. Both  $T_{\cup}$  and  $T_{\cap}$  has subset semigroup topological zero divisors.

Infact we have infinite number of subset zero divisors. Further  $T_{\cup}$  and  $T_{\cap}$  has subset semigroup topological zero divisors.  $T_{\cup}$  and  $T_{\cap}$  has subset semigroup topological zero divisors.

Take  $M_1 = \{\text{Collection of all subsets from the subsemigroup}$



$$P_1 = \left\{ \begin{array}{c} \left[ \begin{array}{c} p_1 \\ p_2 \\ 0 \\ 0 \\ 0 \\ 0 \\ 0 \end{array} \right] \\ p_1, p_2 \in Q \} \subseteq S$$

and

$M_2 = \{ \text{Collection of all subsets from the subsemigroup}$

$$P_2 = \left\{ \begin{array}{c} \left[ \begin{array}{c} 0 \\ 0 \\ p_1 \\ p_2 \\ 0 \\ 0 \\ 0 \end{array} \right] \\ p_1, p_2 \in Q \} \subseteq S$$

and

$M_3 = \{ \text{Collection of all subsets from the subsemigroup}$

$$P_3 = \left\{ \begin{array}{c} \left[ \begin{array}{c} 0 \\ 0 \\ 0 \\ 0 \\ p_1 \\ p_2 \\ p_3 \end{array} \right] \\ p_1, p_2, p_3 \in Q \subseteq P \} \subseteq S$$

are the subset subsemigroups of S.

$$\text{We see } P_i \times P_j = \left\{ \begin{bmatrix} 0 \\ 0 \\ 0 \\ 0 \\ 0 \\ 0 \\ 0 \end{bmatrix} \right\}; 1 \leq i, j \leq 3, i \neq j.$$

We see if  $P_i \subset T_\cup$  (or  $T_\cap$ );  $1 \leq i \leq 3$  are subset subsemigroup topological subspaces and are such that

$$P_i \times P_j = \left\{ \begin{bmatrix} 0 \\ 0 \\ 0 \\ 0 \\ 0 \\ 0 \\ 0 \end{bmatrix} \right\}; 1 \leq i, j \leq 3, i \neq j;$$

which is a product subset semigroup topological subspaces, is a zero divisor in  $T_\cup$  and  $T_\cap$ .

We have infinite number of subset zero divisors.

$$\text{Take } A = \left\{ \begin{bmatrix} 5 \\ 0 \\ 0 \\ 0 \\ 0 \\ 0 \\ 0 \end{bmatrix}, \begin{bmatrix} 8 \\ 0 \\ 0 \\ 0 \\ 0 \\ 0 \\ 0 \end{bmatrix}, \begin{bmatrix} 17 \\ 5/7 \\ 0 \\ 0 \\ 0 \\ 0 \\ 0 \end{bmatrix}, \begin{bmatrix} 0 \\ 8/13 \\ 0 \\ 0 \\ 0 \\ 0 \\ 0 \end{bmatrix}, \begin{bmatrix} 0 \\ -5/2 \\ 0 \\ 0 \\ 0 \\ 0 \\ 0 \end{bmatrix}, \begin{bmatrix} -9/19 \\ 0 \\ 0 \\ 0 \\ 0 \\ 0 \\ 0 \end{bmatrix} \right\}$$

$$\text{and } B = \left\{ \begin{bmatrix} 0 \\ 0 \\ 3/7 \\ 0 \\ 0 \\ 5/11 \end{bmatrix}, \begin{bmatrix} 0 \\ 0 \\ -11 \\ 0 \\ -13/2 \\ -11/2 \end{bmatrix}, \begin{bmatrix} 0 \\ 0 \\ -9 \\ 6 \\ 9/2 \\ 5/23 \end{bmatrix} \right\} \in S;$$

$$A \times B = \left\{ \begin{bmatrix} 5 \\ 0 \\ 0 \\ 0 \\ 0 \\ 0 \end{bmatrix}, \begin{bmatrix} 8 \\ 0 \\ 0 \\ 0 \\ 0 \\ 0 \end{bmatrix}, \begin{bmatrix} 17 \\ 5/7 \\ 0 \\ 0 \\ 0 \\ 0 \end{bmatrix}, \begin{bmatrix} 0 \\ 8/13 \\ 0 \\ 0 \\ 0 \\ 0 \end{bmatrix}, \begin{bmatrix} 0 \\ -5/2 \\ 0 \\ 0 \\ 0 \\ 0 \end{bmatrix}, \begin{bmatrix} -9/19 \\ 0 \\ 0 \\ 0 \\ 0 \\ 0 \end{bmatrix} \right\} \times$$

$$\left\{ \begin{bmatrix} 0 \\ 0 \\ 3/7 \\ 0 \\ 0 \\ 5/11 \end{bmatrix}, \begin{bmatrix} 0 \\ 0 \\ -11 \\ 0 \\ -13/2 \\ -11/2 \end{bmatrix}, \begin{bmatrix} 0 \\ 0 \\ -9 \\ 6 \\ 9/2 \\ 5/23 \end{bmatrix} \right\}$$

$$= \left\{ \begin{bmatrix} 0 \\ 0 \\ 0 \\ 0 \\ 0 \\ 0 \end{bmatrix} \right\} \text{ is a subset zero divisor.}$$

S has infinite number of subset zero divisors. Further  $T_{\cup}$  and  $T_{\cap}$  has infinite number of subset semigroup topological zero divisor subspaces. Even if Q is replaced by  $Q^+ \cup \{0\}$  or  $\langle Q \cup I \rangle$  or  $R$  or  $R^+ \cup \{0\}$  or  $\langle R \cup I \rangle$  or  $C$  or  $\langle C \cup I \rangle$  we have the same conclusions to be true.

That is  $T_{\cup}$  and  $T_{\cap}$  has infinite number of subset semigroup topological zero divisors subspaces.

**Example 2.13:** Let  $S = \{\text{Collection of all subsets from the semigroup } Z_{12} \times Z_7 \times Z_{15}\}$  be the subset semigroup.  $T_{\circ}, T_{\cup}$  and  $T_{\cap}$  are the three subset semigroup topological spaces.

Clearly S has only finite number of subset zero divisors. Further  $T_{\cup}$  and  $T_{\cap}$  has only finite number of subset semigroup topological zero divisors.

$$\begin{aligned} \text{Take } A &= \{(4, 0, 5), (6, 0, 10), (8, 0, 0)\} \text{ and} \\ B &= \{(6, 0, 3), (0, 5, 0), (6, 5, 09), (6, 7, 3)\} \in T_{\cup} \text{ (or } T_{\cap}) \end{aligned}$$

We see

$$\begin{aligned} A \times B &= \{(4, 0, 5), (6, 0, 10), (8, 0, 0)\} \times \{(6, 0, 3), \\ &\quad (0, 5, 0), (6, 5, 09), (6, 7, 3)\} \\ &= \{(0, 0, 0)\}. \end{aligned}$$

We see  $T_{\cup}$  (and  $T_{\cap}$ ) have only finite number of subset topological subspaces.

**Example 2.14:** Let  $S = \{\text{Collection of all subsets from the semigroup } C(Z_{15}) (g_1, g_2, g_3); g_1^2 = g_1, g_2^2 = -g_2, g_3^2 = 0, g_i g_j = g_j g_i = 0, i \neq j, 1 \leq i, j \leq 3\}$  be the subset semigroup.

$\alpha(S) < \infty$ .  $T_{\circ}, T_{\cup}$  and  $T_{\cap}$  are subset semigroup topological spaces of finite order.

We have only finite number of subset zero divisors.

$$\text{Let } A = \{5g_1, 3g_2, 10i_Fg_1, i_Fg_2, 10g_1 + 6i_Fg_2, 14g_2\} \text{ and}$$

$B = \{g_3, 7g_3, 6i_Fg_3, 8i_Fg_3\} \in T_{\cup}$  is such that  
 $A \times B = \{0\}$  as  $g_i g_j = 0$  if  $i \neq j, 1 \leq i, j \leq 3$ .

Let  $M_1 = \{\text{Collection of all subsets from the subsemigroup } C(Z_{15})g_1\} \subseteq S$  and  $M_2 = \{\text{Collection of all subsets from the subsemigroup } C(Z_{15})g_2\} \subseteq S$  be the subset subsemigroup.

$T_{\cup}^{M_1}, T_{\cap}^{M_1}, T_{\cup}^{M_2}$  and  $T_{\cap}^{M_2}$  are subset subsemigroup topological subspaces.

We see  $M_1 \times M_2 = \{0\}$ , however we have only finite number of zero divisors, so only finite number of subset semigroup topological subspaces.

**Example 2.15:** Let  $S = \{\text{Collection of all subsets from the semigroup}$

$$P = \left\{ \left[ \begin{array}{cccccc} a_1 & a_2 & a_3 & a_4 & a_5 & a_6 \\ a_7 & a_8 & a_9 & a_{10} & a_{11} & a_{12} \end{array} \right] \mid a_i \in C(Z_{19}), 1 \leq i \leq 12 \right\}$$

be the subset semigroup.

$T_{\cup}$  and  $T_{\cap}$  are the subset semigroup topological spaces.

We have only finite number of subset zero divisors and subset semigroup topological subspaces.

**Example 2.16:** Let  $S = \{\text{Collection of all subsets from the semigroup}$

$$P = \left\{ \left[ \begin{array}{cc} a_1 & a_2 \\ a_3 & a_4 \end{array} \right] \mid a_i \in Z(g), 1 \leq i \leq 4 \right\}$$

be the subset semigroup.

$T_o$ ,  $T_\cup$  and  $T_\cap$  are subset semigroup topological spaces of  $S$ .  $T_\cup$  and  $T_\cap$  have subset zero divisors.

Further  $M_1 = \{ \text{Collection of all subsets from the subsemigroup } P_1 = \left\{ \left[ \begin{array}{cc} a_1 & 0 \\ a_2 & 0 \end{array} \right] \mid a_1, a_2 \in Z(g) \} \} \subseteq T_\cup \text{ (or } T_\cap) \text{ and}$

$M_2 = \{ \text{Collection of all subsets from the subsemigroup}$

$$P_2 = \left\{ \left[ \begin{array}{cc} 0 & a_1 \\ 0 & a_2 \end{array} \right] \mid a_1, a_2 \in Z(g) \} \subseteq T_\cup \text{ (or } T_\cap) \text{ are the}$$

subset subsemigroup topological subspaces of  $T_\cup$  (or  $T_\cap$ ).

Clearly  $M_1 \times M_2 = \left\{ \left( \begin{array}{cc} 0 & 0 \\ 0 & 0 \end{array} \right) \right\}$ . Every element  $A \in M_1$  is

such that for every  $B \in M_2$  we have  $A \times B = \left\{ \left( \begin{array}{cc} 0 & 0 \\ 0 & 0 \end{array} \right) \right\}$ .

Infact  $S$  has infinite number of subset zero divisors.

**Example 2.17:** Let  $S = \{ \text{Collection of all subsets from the semigroup}$

$$M = \left\{ \left[ \begin{array}{cc} a_1 & a_2 \\ a_3 & a_4 \\ a_5 & a_6 \end{array} \right] \mid a_i \in Z_{15} \times Z_{24}; \times_n, 1 \leq i \leq 6 \} \right\}$$

be the subset semigroup.  $T_o$ ,  $T_\cup$  and  $T_\cap$  be the subset semigroup topological spaces of  $S$ .

$$\text{Let } A = \left\{ \left[ \begin{array}{cc} (3,2) & (4,5) \\ (0,1) & (8,3) \\ (7,3) & (4,9) \end{array} \right], \left[ \begin{array}{cc} (9,0) & (2,2) \\ (4,5) & (7,3) \\ (0,5) & (2,1) \end{array} \right] \right\}$$

$$\text{and } B = \left\{ \left[ \begin{array}{cc} (3,6) & (4,0) \\ (0,7) & (1,2) \\ (3,5) & (7,1) \end{array} \right] \right\} \in S.$$

$$A \times_n B = \left\{ \left[ \begin{array}{cc} (3,2) & (4,5) \\ (0,1) & (8,3) \\ (7,3) & (4,9) \end{array} \right], \left[ \begin{array}{cc} (9,0) & (2,2) \\ (4,5) & (7,3) \\ (0,5) & (2,1) \end{array} \right] \right\} \times_n$$

$$\left\{ \left[ \begin{array}{cc} (3,6) & (4,0) \\ (0,7) & (1,2) \\ (3,5) & (7,1) \end{array} \right] \right\}$$

$$= \left\{ \left[ \begin{array}{cc} (9,12) & (1,0) \\ (0,7) & (8,6) \\ (6,15) & (13,9) \end{array} \right], \left[ \begin{array}{cc} (12,0) & (8,0) \\ (0,11) & (7,6) \\ (0,1) & (14,1) \end{array} \right] \right\} \in T_{\cup} (T_{\cap}).$$

This is the way the operation of the semigroup is carried into the subset semigroup topological spaces.

$$\text{Let } A = \left\{ \left[ \begin{array}{cc} (3,6) & (5,2) \\ (3,12) & (10,8) \\ (0,4) & (5,0) \end{array} \right] \right\} \text{ and } B = \left\{ \left[ \begin{array}{cc} (5,4) & (3,12) \\ (10,8) & (6,6) \\ (9,6) & (3,19) \end{array} \right] \right\} \in S.$$

We find

$$A \times_n B = \left\{ \left[ \begin{array}{cc} (3,6) & (5,2) \\ (3,12) & (10,8) \\ (0,4) & (5,0) \end{array} \right] \right\} \times_n \left\{ \left[ \begin{array}{cc} (5,4) & (3,12) \\ (10,8) & (6,6) \\ (9,6) & (3,19) \end{array} \right] \right\}$$

$$= \left\{ \left[ \begin{array}{cc} (0,0) & (0,0) \\ (0,0) & (0,0) \\ (0,0) & (0,0) \end{array} \right] \right\} \text{ is a subset zero divisors of } S.$$

**Example 2.18:** Let  $S = \{\text{Collection of all subsets from the semigroup}\}$

$$M = \left\{ \sum_{i=0}^{\infty} a_i x^i \mid a_i \in Z_{12} \right\}$$

be the subset semigroup.  $T_o$ ,  $T_{\cup}$  and  $T_{\cap}$  are subset semigroup topological spaces.

$T_o$ ,  $T_{\cup}$  and  $T_{\cap}$  are of infinite order. We have subset zero divisors.

$$\text{Take } A = \{3x^8 + 6x^2 + 9, 6x^5 + 3x^3 + 9x + 6, 3x^2 + 9\} \text{ and } B = \{4x^3 + 8x + 4, 4x^8 + 8, 4x^2 + 8x^3 + 8, 8x + 8\} \in S.$$

We see  $A \times B = \{0\}$  is a subset zero divisors of  $S$ .

**Example 2.19:** Let  $S = \{\text{Collection of all subsets from the semigroup}\}$

$$P = \left\{ \sum_{i=0}^{\infty} a_i x^i \mid a_i \in Z^+ \cup \{0\} \right\}$$

be the subset semigroup.

$T_o$ ,  $T_{\cup}$  and  $T_{\cap}$  are the subset semigroup topological spaces.

$S$  has no subset zero divisors.

**Example 2.20 :** Let  $S = \{\text{Collection of all subsets from the semigroup}\}$



$$P = \left\{ \left[ \begin{array}{ccc} a_1 & a_2 & a_3 \\ a_4 & a_5 & a_6 \\ a_7 & a_8 & a_9 \\ a_{10} & a_{11} & a_{12} \\ a_{13} & a_{14} & a_{15} \end{array} \right] \mid a_i \in Z^+ \cup \{0\}; 1 \leq i \leq 15 \right\}$$

be the subset semigroup.

$T_\circ$ ,  $T_\cup$  and  $T_\cap$  are subset semigroup topological spaces.  $T_\cup$  and  $T_\cap$  are subset topological zero divisors.

We see  $M_1 = \{\text{Collection of all subsets from the subset semigroup}\}$

$$P_1 = \left\{ \left[ \begin{array}{ccc} 0 & a_1 & 0 \\ 0 & a_2 & 0 \\ 0 & a_3 & 0 \\ 0 & a_4 & 0 \\ 0 & a_5 & 0 \end{array} \right] \mid a_i \in Z^+ \cup \{0\}; 1 \leq i \leq 5 \right\} \subseteq P \subseteq T_\cup$$

(or  $T_\cap$ ) and  $M_2 = \{\text{Collection of all subsets from the subset semigroup}\}$

$$P_2 = \left\{ \left[ \begin{array}{ccc} 0 & 0 & a_1 \\ 0 & 0 & a_2 \\ 0 & 0 & a_3 \\ 0 & 0 & a_4 \\ 0 & 0 & a_5 \end{array} \right] \mid a_i \in Z^+ \cup \{0\}; 1 \leq i \leq 5 \right\} \subseteq P \subseteq T_\cup$$

(or  $T_\cap$ ) be two subset semigroup topological subspaces.

$$\text{We see } P_1 \times P_2 = \left\{ \begin{array}{c} \left[ \begin{array}{ccc} 0 & 0 & 0 \\ 0 & 0 & 0 \\ 0 & 0 & 0 \\ 0 & 0 & 0 \\ 0 & 0 & 0 \end{array} \right] \end{array} \right\}.$$

In fact  $T_{\cup}$  and  $T_{\cap}$  have infinite number of subset semigroup topological zero divisors.

**Example 2.21:** Let  $S = \{\text{Collection of all subsets from the semigroup } P = Q^+ \cup \{0\} \text{ under '+'}\}$  be the subset semigroup.  $M = \{\text{Collection of all subsets from the subsemigroup } P_1 = Z^+ \cup \{0\} \text{ under '+'}\}$  be the subset semigroup. Now if  $T_o$ ,  $T_{\cup}$  and  $T_{\cap}$  are subset semigroup topological spaces of  $S$ .  $T_o^M$ ,  $T_{\cup}^M$  and  $T_{\cap}^M$  are subset subsemigroup of  $T_o$ ,  $T_{\cup}$  and  $T_{\cap}$  respectively. In fact  $T_o$ ,  $T_{\cup}$  and  $T_{\cap}$  contain infinitely many subset subsemigroup topological subspaces.

**Example 2.22:** Let  $S = \{\text{Collection all subsets from the semigroup } C(Z_{30})\}$  be the subset semigroup.  $T_o$ ,  $T_{\cup}$  and  $T_{\cap}$  are the subset topological semigroup spaces.

Let  $M = \{\text{Collection of all subsets from the subsemigroup } Z_{30}\} \subseteq S$  be the subset semigroup.  $T_o^M$ ,  $T_{\cup}^M$  and  $T_{\cap}^M$  are subset subsemigroup topological subspaces of  $T_o$ ,  $T_{\cup}$  and  $T_{\cap}$  respectively.

However  $T_o$ ,  $T_{\cup}$  and  $T_{\cap}$  have only a finite number of subset subsemigroup topological subspaces.

**Example 2.23:** Let  $S = \{\text{Collection all subsets from the semigroup } P = \{(a_1, a_2, a_3, a_4, a_5, a_6) \mid a_i \in Z_{42}; 1 \leq i \leq 6\}\}$  be the subset semigroup.  $T_o$ ,  $T_{\cup}$  and  $T_{\cap}$  be the subset semigroup topological spaces of  $S$ .  $S$  has only a finite number of subset

subsemigroups.  $T_0$ ,  $T_\cup$  and  $T_\cap$  have only finite number of subset semigroup topological subspaces.

**Example 2.24:** Let  $S = \{\text{Collection of all subsets from the semigroup } L = \{L, \times = \cap\}\}$

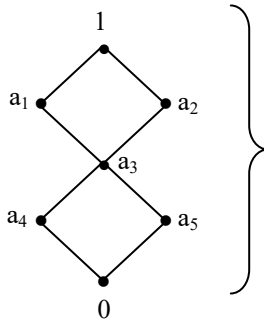

be the subset semigroup.  $T_0$ ,  $T_\cup$  and  $T_\cap$  be the subset semigroup topological spaces.

$$\text{Let } A = \{a_1, a_3, 0\} \text{ and } B = \{a_5, a_2, 1, a_3\} \in T_0$$

We see

$$\begin{aligned} A \cup B &= \{a_1, a_3, 0\} \cup \{a_5, a_2, 1, a_3\} \\ &= \{0, 1, a_1, a_2, a_3, a_5\} \end{aligned}$$

and  $A \cap B = \{a_1, a_3, 0\} \cap \{a_5, a_2, 1, a_3\}$   
 $= \{a_3\}$  are in  $T_0$

Let  $A, B \in T_\cup$

$$\begin{aligned} A \cup B &= \{a_1, a_3, 0\} \cup \{a_5, a_2, 1, a_3\} \\ &= \{0, 1, a_1, a_2, a_3, a_5\} \end{aligned}$$

and

$$\begin{aligned} A \times B &= \{a_1, a_3, 0\} \times \{a_5, a_2, 1, a_3\} \\ &= \{0, a_1, a_3, a_5\} \text{ are in } T_\cup. \end{aligned}$$

$T_0$  and  $T_\cup$  are two different subset semigroup topological spaces.

Let  $A, B \in T_{\cap}$ ,

$$\begin{aligned} A \times B &= \{a_1, a_3, 0\} \cup \{a_5, a_2, 1, a_3\} \\ &= \{0, a_1, a_3, a_5\} \end{aligned}$$

and

$$\begin{aligned} A \cap B &= \{a_1, a_3, 0\} \cap \{a_5, a_2, 1, a_3\} \\ &= \{a_3\} \text{ are in } T_{\cap}. \end{aligned}$$

We see  $T_{\cap}$  is different from  $T_0$  and  $T_{\cup}$  as topological spaces.

$$o(T_{\cup}) = 2^7 - 1 \text{ and } o(T_0) = o(T_{\cap}) = 2^7.$$

If in the above example we use the lattice ‘ $\cup$ ’ as + we get  $T_{\cup}$  and  $T_{\cap}$  to be different for the + on S.

For the same  $A, B \in T_{\cup}$ .

We get

$$\begin{aligned} A + B &= \{a_1, a_3, 0\} + \{a_5, a_2, 1, a_3\} \\ &= \{1, a_2, a_3, a_5, a_1\} \end{aligned}$$

$$\neq A \cap B \text{ or } A \cup B \text{ or } A \times B.$$

However  $T_0$  is the same be the semilattice L under  $\cup$  or  $\cap$ .

We have subset subsemigroup topological subspaces of  $T_0$ ,  $T_{\cup}$  and  $T_{\cap}$ .

**Example 2.25:** Let  $S = \{\text{Collection of all subsets from the semigroup } Z_2S(3) \text{ under product}\}$  be the subset semigroup. Clearly S is non commutative so the spaces  $T_{\cup}$  and  $T_{\cap}$  will be non commutative subset topological semigroup subspaces.

$$\text{For take } A = \left\{ \begin{pmatrix} 1 & 2 & 3 \\ 1 & 3 & 2 \end{pmatrix} + \begin{pmatrix} 1 & 2 & 3 \\ 3 & 2 & 1 \end{pmatrix}, 1 + \begin{pmatrix} 1 & 2 & 3 \\ 2 & 3 & 1 \end{pmatrix} \right\} \text{ and}$$

$$B = \left\{ 1 + \begin{pmatrix} 1 & 2 & 3 \\ 1 & 3 & 2 \end{pmatrix} + \begin{pmatrix} 1 & 2 & 3 \\ 2 & 1 & 3 \end{pmatrix} \right\} \in T_0.$$

$$\begin{aligned} \text{We see } A \cap B &= \left\{ \begin{pmatrix} 1 & 2 & 3 \\ 1 & 3 & 2 \end{pmatrix} + \begin{pmatrix} 1 & 2 & 3 \\ 3 & 2 & 1 \end{pmatrix}, 1 + \begin{pmatrix} 1 & 2 & 3 \\ 2 & 3 & 1 \end{pmatrix} \right\} \\ &\quad + \left\{ 1 + \begin{pmatrix} 1 & 2 & 3 \\ 1 & 3 & 2 \end{pmatrix} + \begin{pmatrix} 1 & 2 & 3 \\ 2 & 1 & 3 \end{pmatrix} \right\} \\ &= \{\phi\} = B \cap A \text{ and} \end{aligned}$$

$$\begin{aligned} A \cup B &= \left\{ \begin{pmatrix} 1 & 2 & 3 \\ 1 & 3 & 2 \end{pmatrix} + \begin{pmatrix} 1 & 2 & 3 \\ 3 & 2 & 1 \end{pmatrix}, 1 + \begin{pmatrix} 1 & 2 & 3 \\ 2 & 3 & 1 \end{pmatrix} \right\} \cup \\ &\quad \left\{ 1 + \begin{pmatrix} 1 & 2 & 3 \\ 1 & 3 & 2 \end{pmatrix} + \begin{pmatrix} 1 & 2 & 3 \\ 2 & 1 & 3 \end{pmatrix} \right\} \\ &= \left\{ \begin{pmatrix} 1 & 2 & 3 \\ 1 & 3 & 2 \end{pmatrix} + \begin{pmatrix} 1 & 2 & 3 \\ 3 & 2 & 1 \end{pmatrix}, 1 + \begin{pmatrix} 1 & 2 & 3 \\ 2 & 3 & 1 \end{pmatrix}, \right. \\ &\quad \left. 1 + \begin{pmatrix} 1 & 2 & 3 \\ 1 & 3 & 2 \end{pmatrix} + \begin{pmatrix} 1 & 2 & 3 \\ 2 & 1 & 3 \end{pmatrix} \right\} = B \cup A \text{ are in } T_o. \end{aligned}$$

Thus  $T_o$  is a subset semigroup topological space which is clearly commutative.

Let  $A, B \in T_\cup = \{S, \cup, \times\}$  we find

$$\begin{aligned} A \cup B &= \left\{ \begin{pmatrix} 1 & 2 & 3 \\ 1 & 3 & 2 \end{pmatrix} + \begin{pmatrix} 1 & 2 & 3 \\ 3 & 2 & 1 \end{pmatrix}, 1 + \begin{pmatrix} 1 & 2 & 3 \\ 2 & 3 & 1 \end{pmatrix} \right\} \cup \\ &\quad \left\{ 1 + \begin{pmatrix} 1 & 2 & 3 \\ 1 & 3 & 2 \end{pmatrix} + \begin{pmatrix} 1 & 2 & 3 \\ 2 & 1 & 3 \end{pmatrix} \right\} \end{aligned}$$

$$\begin{aligned}
 &= \left\{ \left( \begin{pmatrix} 1 & 2 & 3 \\ 1 & 3 & 2 \end{pmatrix} + \begin{pmatrix} 1 & 2 & 3 \\ 3 & 2 & 1 \end{pmatrix}, 1 + \begin{pmatrix} 1 & 2 & 3 \\ 2 & 3 & 1 \end{pmatrix}, \right. \\
 &\qquad \qquad \qquad \left. 1 + \begin{pmatrix} 1 & 2 & 3 \\ 1 & 3 & 2 \end{pmatrix} + \begin{pmatrix} 1 & 2 & 3 \\ 2 & 1 & 3 \end{pmatrix} \right\} \text{ and} \\
 A \times B &= \left\{ \left( \begin{pmatrix} 1 & 2 & 3 \\ 1 & 3 & 2 \end{pmatrix} + \begin{pmatrix} 1 & 2 & 3 \\ 3 & 2 & 1 \end{pmatrix}, 1 + \begin{pmatrix} 1 & 2 & 3 \\ 2 & 3 & 1 \end{pmatrix} \right) \times \right. \\
 &\qquad \qquad \qquad \left. \left\{ 1 + \begin{pmatrix} 1 & 2 & 3 \\ 1 & 3 & 2 \end{pmatrix} + \begin{pmatrix} 1 & 2 & 3 \\ 2 & 1 & 3 \end{pmatrix} \right\} \right\} \\
 &= \left\{ \begin{pmatrix} 1 & 2 & 3 \\ 2 & 3 & 1 \end{pmatrix} + \begin{pmatrix} 1 & 2 & 3 \\ 3 & 2 & 1 \end{pmatrix} + \begin{pmatrix} 1 & 2 & 3 \\ 2 & 1 & 3 \end{pmatrix} + \right. \\
 &\qquad \begin{pmatrix} 1 & 2 & 3 \\ 1 & 3 & 2 \end{pmatrix} + 1 + \begin{pmatrix} 1 & 2 & 3 \\ 1 & 3 & 2 \end{pmatrix} + \\
 &\qquad \begin{pmatrix} 1 & 2 & 3 \\ 1 & 3 & 2 \end{pmatrix} + \begin{pmatrix} 1 & 2 & 3 \\ 3 & 2 & 1 \end{pmatrix} + \begin{pmatrix} 1 & 2 & 3 \\ 1 & 2 & 3 \end{pmatrix} + \begin{pmatrix} 1 & 2 & 3 \\ 2 & 3 & 1 \end{pmatrix} + \\
 &\qquad \left. \begin{pmatrix} 1 & 2 & 3 \\ 2 & 3 & 1 \end{pmatrix} + \begin{pmatrix} 1 & 2 & 3 \\ 1 & 3 & 2 \end{pmatrix} \right\} \quad \dots I
 \end{aligned}$$

and

$$\begin{aligned}
 B \times A &= \left\{ 1 + \begin{pmatrix} 1 & 2 & 3 \\ 1 & 3 & 2 \end{pmatrix} + \begin{pmatrix} 1 & 2 & 3 \\ 2 & 1 & 3 \end{pmatrix} \right\} \times \\
 &\qquad \qquad \qquad \left\{ \begin{pmatrix} 1 & 2 & 3 \\ 1 & 3 & 2 \end{pmatrix} + \begin{pmatrix} 1 & 2 & 3 \\ 3 & 2 & 1 \end{pmatrix}, 1 + \begin{pmatrix} 1 & 2 & 3 \\ 2 & 3 & 1 \end{pmatrix} \right\}
 \end{aligned}$$

$$\begin{aligned}
 &= \left\{ \begin{pmatrix} 1 & 2 & 3 \\ 1 & 3 & 2 \end{pmatrix} + \begin{pmatrix} 1 & 2 & 3 \\ 3 & 2 & 1 \end{pmatrix} + \begin{pmatrix} 1 & 2 & 3 \\ 1 & 2 & 3 \end{pmatrix} + \begin{pmatrix} 1 & 2 & 3 \\ 3 & 1 & 2 \end{pmatrix}, \right. \\
 &\quad \left. \begin{pmatrix} 1 & 2 & 3 \\ 3 & 1 & 2 \end{pmatrix} + \begin{pmatrix} 1 & 2 & 3 \\ 2 & 3 & 1 \end{pmatrix}, 1 + \begin{pmatrix} 1 & 2 & 3 \\ 1 & 3 & 2 \end{pmatrix} + \begin{pmatrix} 1 & 2 & 3 \\ 2 & 1 & 3 \end{pmatrix} + \right. \\
 &\quad \left. \begin{pmatrix} 1 & 2 & 3 \\ 2 & 3 & 1 \end{pmatrix} + \begin{pmatrix} 1 & 2 & 3 \\ 2 & 1 & 3 \end{pmatrix} + \begin{pmatrix} 1 & 2 & 3 \\ 3 & 2 & 1 \end{pmatrix} \right\} \quad \dots \text{ II}
 \end{aligned}$$

Clearly I and II are different so  $A \times B \neq B \times A$ . Thus  $T_{\cup}$  and  $T_{\cap}$  are non commutative subset semigroup topological spaces of finite order. So by using a non commutative semigroup we get non commutative subset semigroup topological spaces.

However  $T_{\cup}$  and  $T_{\cap}$  has subset subsemigroup topological subspaces which are commutative. For take  $M_1 = \{\text{Collection of all subsets from the commutative subsemigroup } Z_2P_1 \text{ where}$

$$P_1 = \left\{ 1 = \begin{pmatrix} 1 & 2 & 3 \\ 1 & 2 & 3 \end{pmatrix}, \begin{pmatrix} 1 & 2 & 3 \\ 2 & 3 & 1 \end{pmatrix}, \begin{pmatrix} 1 & 2 & 3 \\ 3 & 1 & 2 \end{pmatrix} \right\} \subseteq S_3 \subseteq S;$$

$M_1$  is a commutative subset subsemigroup of  $S$ .  $T_{\cup}^{M_1}$  and  $T_{\cap}^{M_1}$  are commutative subset subsemigroup topological subspaces of  $T_{\cup}$  and  $T_{\cap}$  respectively.

In views of this we just give the following result.

**THEOREM 2.3:** *Let*

$S = \{\text{Collection of all subsets from the semigroup } (P, *)\}$  *be the subset semigroup.*

- (i)  $T_o$  *is always subset semigroup topological space which is commutative.*

- (ii)  $T_{\cup}$  and  $T_{\cap}$  are non commutative subset semigroup topological space if and only if the semigroup  $(P, *)$  is a non commutative semigroup.

The proof is direct hence left as an exercise to the reader.

**Example 2.26:** Let  $S = \{\text{Collection of all subsets from the semigroup } Z_5A_4 \text{ under } \times\}$  be the subset semigroup.  $T_o$  is a subset semigroup commutative topological space but  $T_{\cup}$  and  $T_{\cap}$  are both non commutative subset semigroup topological spaces of  $S$ .

Now we proceed on to describe the notion of subset semigroup Smarandache topological space (subset Smarandache semigroup topological space) in the following.

**DEFINITION 2.3:** Let

$S = \{\text{Collection of all subsets from the semigroup } \{P, *\}\}$  be the subset semigroup. Suppose  $(P, *)$  is a Smarandache semigroup then we know  $S$  is also a  $S$ -subset semigroup. If  $S$  is a  $S$ -subset semigroup then we call  $T_o$ ,  $T_{\cup}$  and  $T_{\cap}$  to be Smarandache subset semigroup topological spaces.

We will illustrate this situation by an example or two.

**Example 2.27:** Let  $S = \{\text{Collection of all subsets from the semigroup } P = (ZS_{10}, \times)\}$  be the subset semigroup.  $T_o$ ,  $T_{\cup}$  and  $T_{\cap}$  are subset semigroup topological spaces of infinite order. Both  $T_{\cup}$  and  $T_{\cap}$  are non commutative as subset semigroup topological spaces but  $T_o$  is a commutative semigroup topological spaces.

We see  $T_{\cup}$  and  $T_{\cap}$  has several subset semigroup topological which are commutative.

We see  $T_o$ ,  $T_{\cup}$  and  $T_{\cap}$  are all Smarandache subset semigroup topological spaces of infinite order.



**Example 2.28:** Let  $S = \{\text{Collection of all subsets from the semigroup } (P, \times) = \{(a_1, a_2, a_3, a_4) \mid a_i \in D_{2,7} = \{a, b \mid a^2 = b^7 = 1, bab = a\}, 1 \leq i \leq 4\}\}$  be the subset semigroup.

$S$  is a Smarandache subset semigroup.

Let  $A = \{(ab, a, 1, b), (b, b^2, 1, a), (b, b, b, a)\}$  and

$B = \{(a, a, 1, b), (b, ab, ab^2, 1)\} \in T_o (T_\cup \text{ and } T_\cap)$ .

Let  $A, B \in T_\cup$  (or  $T_\cap$ ).

$$\begin{aligned} A \times B &= \{(ab, a, 1, b), (b, b^2, 1, a), (b, b, b, a)\} \times \\ &\quad \{(a, a, 1, b), (b, ab, ab^2, 1)\} \\ &= \{(aba, 1, 1b^2), (ba, b^2a, 1, ab), (ba, ba, b, ab), \\ &\quad (ab^2, b, ab^2, b), (b^2 b^2ab, ab^2 a) (b^2, bab, bab^2, \\ &\quad a)\} \in T_\cup \text{ (or } T_\cap). \end{aligned}$$

It is easily verified  $A \times B \neq B \times A$  for  $A, B \in T_\cup$  (or  $T_\cap$ )

Further  $T_\cup, T_o$  and  $T_\cap$  are subset Smarandache semigroup topological spaces of finite order which is non commutative.

However  $T_\cup$  and  $T_\cap$  has subset semigroup topological subspaces which are commutative.

For take  $M_1 = \{\text{Collection of all subsets from the subsemigroup } P_1 = \{(a_1, a_2, a_3, a_4) \mid a_i \in \{b \mid b^7 = 1\}; 1 \leq i \leq 7\}\} \subseteq S$ ;  $M_1$  is a subset topological subsemigroup subspace of  $T_\cup$  and  $T_\cap$ .

**Example 2.29:** Let  $S = \{\text{Collection of all subsets from the semigroup}$

$$M = \left\{ \begin{array}{c} a_1 \\ a_2 \\ a_3 \\ a_4 \\ a_5 \\ a_6 \end{array} \right\} \quad \{a_i \in A_4; \times_n; 1 \leq i \leq 6\}$$

be the subset semigroup.

$T_\circ$ ,  $T_\cup$  and  $T_\cap$  be the subset semigroup topological spaces of  $S$ .

$T_\cup$  and  $T_\cap$  are finite non commutative subset semigroup topological spaces.

$T_\circ$ ,  $T_\cup$  and  $T_\cap$  are all Smarandache subset semigroup topological spaces of  $S$ .

$$\text{Take } A = \left\{ \begin{array}{c} \left[ \begin{array}{c} (1 \ 2 \ 3 \ 4) \\ (2 \ 1 \ 4 \ 3) \\ (1 \ 2 \ 3 \ 4) \\ (1 \ 3 \ 4 \ 2) \end{array} \right] \\ 1 \\ 1 \\ 1 \\ \left[ \begin{array}{c} (1 \ 2 \ 3 \ 4) \\ (2 \ 3 \ 1 \ 4) \end{array} \right] \end{array} \right\} \text{ and } B = \left\{ \begin{array}{c} \left[ \begin{array}{c} (1 \ 2 \ 3 \ 4) \\ (2 \ 3 \ 1 \ 4) \\ (1 \ 2 \ 3 \ 4) \\ (2 \ 3 \ 1 \ 4) \end{array} \right] \\ 1 \\ 1 \\ 1 \\ \left[ \begin{array}{c} (1 \ 2 \ 3 \ 4) \\ (3 \ 2 \ 4 \ 1) \end{array} \right] \end{array} \right\} \in S$$

$$\text{(where } 1 = \left( \begin{array}{c} 1 \ 2 \ 3 \ 4 \\ 1 \ 2 \ 3 \ 4 \end{array} \right))$$

$$\text{We find } A \times_n B = \left\{ \begin{array}{c} \left[ \begin{array}{c} (1 \ 2 \ 3 \ 4) \\ (2 \ 1 \ 4 \ 3) \end{array} \right] \\ \left[ \begin{array}{c} (1 \ 2 \ 3 \ 4) \\ (1 \ 3 \ 4 \ 2) \end{array} \right] \\ 1 \\ 1 \\ 1 \\ \left[ \begin{array}{c} (1 \ 2 \ 3 \ 4) \\ (2 \ 3 \ 1 \ 4) \end{array} \right] \end{array} \right\} \times_n$$

$$\left\{ \begin{array}{c} \left[ \begin{array}{c} (1 \ 2 \ 3 \ 4) \\ (2 \ 3 \ 1 \ 4) \end{array} \right] \\ \left[ \begin{array}{c} (1 \ 2 \ 3 \ 4) \\ (2 \ 3 \ 1 \ 4) \end{array} \right] \\ 1 \\ 1 \\ 1 \\ \left[ \begin{array}{c} (1 \ 2 \ 3 \ 4) \\ (3 \ 2 \ 4 \ 1) \end{array} \right] \end{array} \right\}$$

$$= \left\{ \begin{array}{c} \left[ \begin{array}{c} (1 \ 2 \ 3 \ 4) \\ (3 \ 2 \ 4 \ 1) \end{array} \right] \\ \left[ \begin{array}{c} (1 \ 2 \ 3 \ 4) \\ (2 \ 1 \ 4 \ 3) \end{array} \right] \\ 1 \\ 1 \\ 1 \\ \left[ \begin{array}{c} (1 \ 2 \ 3 \ 4) \\ (2 \ 4 \ 3 \ 1) \end{array} \right] \end{array} \right\} \dots I$$

$$\begin{aligned}
 \text{Now } B \times_n A &= \left\{ \left[ \begin{array}{c} \left( \begin{array}{cccc} 1 & 2 & 3 & 4 \end{array} \right) \\ \left( \begin{array}{cccc} 2 & 3 & 1 & 4 \end{array} \right) \\ \left( \begin{array}{cccc} 1 & 2 & 3 & 4 \end{array} \right) \\ \left( \begin{array}{cccc} 2 & 3 & 1 & 4 \end{array} \right) \\ 1 \\ 1 \\ 1 \\ \left( \begin{array}{cccc} 1 & 2 & 3 & 4 \end{array} \right) \\ \left( \begin{array}{cccc} 3 & 2 & 4 & 1 \end{array} \right) \end{array} \right\} \times_n \left\{ \left[ \begin{array}{c} \left( \begin{array}{cccc} 1 & 2 & 3 & 4 \end{array} \right) \\ \left( \begin{array}{cccc} 2 & 1 & 4 & 3 \end{array} \right) \\ \left( \begin{array}{cccc} 1 & 2 & 3 & 4 \end{array} \right) \\ \left( \begin{array}{cccc} 1 & 3 & 4 & 2 \end{array} \right) \\ 1 \\ 1 \\ 1 \\ \left( \begin{array}{cccc} 1 & 2 & 3 & 4 \end{array} \right) \\ \left( \begin{array}{cccc} 2 & 3 & 1 & 4 \end{array} \right) \end{array} \right\} \\
 &= \left\{ \left[ \begin{array}{c} \left( \begin{array}{cccc} 1 & 2 & 3 & 4 \end{array} \right) \\ \left( \begin{array}{cccc} 1 & 4 & 2 & 3 \end{array} \right) \\ \left( \begin{array}{cccc} 1 & 2 & 3 & 4 \end{array} \right) \\ \left( \begin{array}{cccc} 3 & 4 & 1 & 2 \end{array} \right) \\ 1 \\ 1 \\ 1 \\ \left( \begin{array}{cccc} 1 & 2 & 3 & 4 \end{array} \right) \\ \left( \begin{array}{cccc} 1 & 3 & 4 & 2 \end{array} \right) \end{array} \right\} \quad \dots \text{ II}
 \end{aligned}$$

Clearly I and II are different thus  $A \times_n B \neq B \times_n A$ ; so the subset semigroup topological spaces  $T_{\cup}$  and  $T_{\cap}$  are non commutative.

However both  $T_{\cup}$  and  $T_{\cap}$  contain many subset semigroup topological subspaces which are commutative.

**Example 2.30:** Let  $S = \{\text{Collection of all subsets from the semigroup}\}$

$$(P, \times_n) = \left\{ \left[ \begin{array}{ccc} a & b & c \\ d & e & f \\ g & h & i \end{array} \right] \mid a, b, c, d, e, f, g, h, i \in S_3 \times D_{2,4} \right\}$$

be the subset semigroup.  $S$  is of finite order.  $S$  is a non commutative subset semigroup.

Further  $T_\circ$ ,  $T_\cup$  and  $T_\cap$  are finite subset semigroup topological spaces which are Smarandache.  $T_\cup$  and  $T_\cap$  are finite subset subsemigroup Smarandache non commutative topological spaces.

$$\text{Let } A = \left\{ \left[ \begin{array}{ccc} (1, a) & (p_1, 1) & (1, b) \\ (1, 1) & (p_2, 1) & (1, b^2) \\ (1, b^3) & (p_3, 1) & (p_2, b^3) \end{array} \right] \right\} \text{ and}$$

$$B = \left\{ \left[ \begin{array}{ccc} (p_1, b) & (p_3, 1) & (1, a) \\ (1, 1) & (p_4, 1) & (1, ab^2) \\ (1, ab) & (p_5, 1) & (p_1, ab) \end{array} \right] \right\} \in T_\cup \text{ (or } T_\cap).$$

We show  $A \times_n B \neq B \times_n A$ .

Consider

$$A \times_n B = \left\{ \left[ \begin{array}{ccc} (1, a) & (p_1, 1) & (1, b) \\ (1, 1) & (p_2, 1) & (1, b^2) \\ (1, b^3) & (p_3, 1) & (p_2, b^3) \end{array} \right] \right\} \times_n$$

$$\left\{ \left[ \begin{array}{ccc} (p_1, b) & (p_3, 1) & (1, a) \\ (1, 1) & (p_4, 1) & (1, ab^2) \\ (1, ab) & (p_5, 1) & (p_1, ab) \end{array} \right] \right\}$$

$$\text{(where } \{1 = \begin{pmatrix} 1 & 2 & 3 \\ 1 & 2 & 3 \end{pmatrix}, p_1 = \begin{pmatrix} 1 & 2 & 3 \\ 1 & 3 & 2 \end{pmatrix}, p_2 = \begin{pmatrix} 1 & 2 & 3 \\ 3 & 2 & 1 \end{pmatrix}, \\ p_3 = \begin{pmatrix} 1 & 2 & 3 \\ 2 & 1 & 3 \end{pmatrix}, p_4 = \begin{pmatrix} 1 & 2 & 3 \\ 2 & 3 & 1 \end{pmatrix} \text{ and } p_5 = \begin{pmatrix} 1 & 2 & 3 \\ 3 & 1 & 2 \end{pmatrix} \} \text{)}$$

$$= \left\{ \begin{bmatrix} (p_1, ab) & (p_5, 1) & (1, ba) \\ (1, 1) & (p_1, 1) & (1, b^2 ab^2) \\ (1, b^3 ab) & (p_3, b^2) & (p_5, b^3 ab) \end{bmatrix} \right\} \quad \dots \text{ I}$$

$$B \times_n A = \left\{ \begin{bmatrix} (p_1, b) & (p_3, 1) & (1, a) \\ (1, 1) & (p_4, 1) & (1, ab^2) \\ (1, ab) & (p_5, 1) & (p_1, ab) \end{bmatrix} \right\} \times_n$$

$$\left\{ \begin{bmatrix} (1, a) & (p_1, 1) & (1, b) \\ (1, 1) & (p_2, 1) & (1, b^2) \\ (1, b^3) & (p_3, 1) & (p_2, b^3) \end{bmatrix} \right\}$$

$$= \left\{ \begin{bmatrix} (p_1, ba) & (p_4, 1) & (1, ab) \\ (1, 1) & (p_3, 1) & (1, a) \\ (1, a) & (p_2, b^2) & (p_3, a) \end{bmatrix} \right\} \quad \dots \text{ II}$$

Clearly I and II are distinct so  $A \times_n B \neq B \times_n A$ , hence  $T_\cup$  and  $T_\cap$  are non commutative subset semigroup topological spaces.

Next if we replace the semigroup by a group in the definition 2.1 then we define S to be a group subset semigroup. We also define  $T_\circ$ ,  $T_\cup$  and  $T_\cap$  as group subset semigroup topological spaces of S.

We will just illustrate them by a few examples.

**Example 2.31:** Let

$S = \{\text{Collection of all subsets from the group } G = \mathbb{R} \setminus \{0\}, \times\}$  be the group subset semigroup.  $T_o$ ,  $T_\cup$  and  $T_\cap$  are group subset semigroup topological spaces of infinite order which is commutative.

$$A = \{4, 8, \sqrt{3}, \sqrt{7} + 1, 0\} \text{ and}$$

$$B = \{2, 1/4, \sqrt{19}, 3, \sqrt{13}, 1\} \in S$$

$$\begin{aligned} A \times B &= \{4, 8, \sqrt{3}, \sqrt{7} + 1, 0\} \times \{2, 1/4, \sqrt{19}, 3, \sqrt{13}, 1\} \\ &= \{4, 8, \sqrt{3}, \sqrt{7} + 1, 0, 16, 2\sqrt{3}, 2 + 2\sqrt{7}, 1, \\ &\quad 2, \sqrt{3}/4, \sqrt{7} + 1/4, 4\sqrt{19}, 8\sqrt{19}, \sqrt{57}, \\ &\quad \sqrt{7 \times 19} + \sqrt{19}, 12, 24, 3\sqrt{3}, 3\sqrt{7} + 3, \\ &\quad 4\sqrt{13}, 8\sqrt{13}, \sqrt{39}, \sqrt{7 \times 13} + \sqrt{13}\} \in T_\cup \\ &\text{(and } T_\cap\text{)}. \end{aligned}$$

All of the spaces are of infinite order and  $T_o$ ,  $T_\cup$  and  $T_\cap$  have infinite number of subset semigroup topological subspaces and all of them are infinite order except.

$$W = \{\text{Collection of all subsets from the subgroup } \{1, -1\}\} \subseteq S.$$

$W = \{\emptyset, \{1\}, \{-1\}, \{1, -1\}\} \subseteq S$  is a subset semigroup.  $T_o^W$ ,  $T_\cup^W$  and  $T_\cap^W$  is a group subset semigroup topological subspaces of finite order.

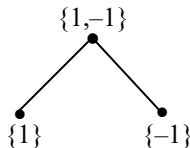

is the tree associated with  $T_o^W$ .

**Example 2.32:** Let

$S = \{\text{Collection of all subsets from the group } S_3\}$  be the group subset semigroup. Clearly  $S$  is non commutative.  $T_\circ$ ,  $T_\cup$  and  $T_\cap$  are group subset semigroup topological spaces.  $T_\cup$  and  $T_\cap$  are non commutative and all the three spaces are of finite order. All the three spaces have group subset semigroup topological subspaces some of which are commutative.

**Example 2.33:** Let

$S = \{\text{Collection of all subsets from the group } D_{2,9} \times S_3 \times A_5\}$  be the group subset semigroup.  $S$  is non commutative and is of finite order.  $T_\circ$ ,  $T_\cup$  and  $T_\cap$  are group subset semigroup topological spaces of finite order. However the spaces  $T_\cup$  and  $T_\cap$  are non commutative but both contain commutative subspaces.

Now having seen examples of group semigroup subsets of infinite and finite order and their related group subset topological semigroup spaces we can also define set ideals subset semigroup topological spaces of subset group semigroup.

We will illustrate this situation by some examples.

**Example 2.34:** Let

$S = \{\text{Collection of all subsets from the semigroup } (Z_{12}, \times)\}$  be the semigroup.

Let  $B = \{0, 3, 6, 9\} \subseteq \{Z_{12}, \times\}$  be the subsemigroup of  $\{Z_{12}, \times\}$ . Now let  $M = \{\text{Collection of all set ideals of } S \text{ over the subset group } B\}$ .

$M$  can be given a topology and  $T_\circ^B$ ,  $T_\cup^B$  and  $T_\cap^B$  will be known as the subset set ideal subsemigroup topological spaces associated with the subsemigroup  $B$ ; where  $T_\circ^B = \{M' = M \cup \{0\}, \cup, \cap\}$ ,  $T_\cup^B = \{M, \cup, \times\}$  and  $T_\cap^B = \{M', \cap, \times\}$ .



$B_1 = \{0, 1, 11\} \subseteq (Z_{12}, \times)$  is a subsemigroup of  $Z_{12}$ .  
 Collection of all set ideals of  $S$  over (or relative to  $B_1$ ) is  $M_1 = \{\{0\}, \{0, 1, 11\}, \{2, 0, 10\}, \{3, 0, 9\}, \{0, 4, 8\}, \{0, 5, 7\}, \{0, 6\}, \{0, 1, 11, 2, 10\}, \{0, 1, 11, 6\}, \{0, 1, 11, 3, 9\}, \{0, 1, 11, 4, 8\}, \{0, 1, 11, 5, 7\}, \{0, 2, 10, 3, 9\}, \{0, 2, 10, 4, 8\}, \dots \{0, 1, 2, 3, 4, 5, 6, 7, 8, 9, 10, 11\}\}$ .

Now  $T_o^{M_1}$ ,  $T_\cup^{M_1}$  and  $T_\cap^{M_1}$  are subset set ideal subsemigroup topological spaces relative to the subsemigroup  $B_1 = \{0, 1, 11\}$ .

Let  $B_2 = \{0, 4\} \subseteq (Z_{12}, \times)$  be a subsemigroup of  $Z_{12}$ .

The collection of all set ideal of  $S$  over the subsemigroup  $B_2$  be  $M_2$  then  $M_2 = \{\{0\}, \{0, 1, 4\}, \{0, 2, 8\}, \{0, 3\}, \{0, 4\}, \{0, 5, 8\}, \{0, 6\}, \{0, 7, 4\}, \{0, 8\}, \{0, 9\}, \{0, 10, 4\}, \{0, 11, 8\} \dots, \{0, 1, 2, \dots, 11\}\} \subseteq S$  gives  $T_o^{M_2}$ ,  $T_\cup^{M_2}$  and  $T_\cap^{M_2}$  as the set ideal subset semigroup topological spaces relative to the subsemigroup  $B_2 = \{0, 4\}$ .

Suppose  $\{0, 6\} \subseteq Z_{12}$  is a subsemigroup of  $Z_{12}$ . We can have  $M_3$  to be the collection of all subset semigroup  $S$  over  $B_3$ ;  $M_3 = \{\{0\}, \{0, 2\}, \{0, 3, 6\}, \{0, 4\}, \{0, 6, 5\}, \{0, 7, 6\}, \{0, 8\}, \{0, 6\}, \{0, 9, 6\}, \{0, 10\}, \{0, 11, 6\}, \dots \{0, 1, 2, \dots, 11\}\} \subseteq S$  is such that  $T_o^{M_3}$ ,  $T_\cup^{M_3}$  and  $T_\cap^{M_3}$  are the set subset ideal semigroup topological spaces of  $S$  relative to the subsemigroup  $B_3 = \{0, 6\}$ . Take  $B_4 = \{1, 5, 0\}$  the subsemigroup of  $S$ . Let  $M_4 = \{\text{Collection of all subset set ideals from } S \text{ relative to the subsemigroup}\}$ .

$M_4 = \{\{0\}, \{0, 5, 1\}, \{2, 10, 0\}, \{4, 8, 0\}, \{6, 0\}, \{7, 11, 0\}, \{9, 0\}, \{0, 1, 5, 9\}, \{0, 3, 9\}, \{0, 2, 10, 9\} \dots \{0, 1, 2, 3, 4, 5, \dots, 11\}$  and  $T_o^{M_4}$ ,  $T_\cup^{M_4}$  and  $T_\cap^{M_4}$  are the set ideal subset topological semigroup spaces of  $S$  relative to the semigroup  $B_4 = \{0, 1, 5\}$ .

Similarly if we take  $B_5 = \{0, 7, 1\} \subseteq Z_{12}$  to be the subsemigroup we take  $M_5 = \{\text{Collection of all set ideals of } S \text{ over the subsemigroup } B_5 = \{0, 1, 7\}\} = \{\{0\}, \{7, 0, 1\}, \{2, 0\},$

$\{3, 7, 1, 0\}, \{0, 7, 1, 4\}, \{1, 2, 7, 0\}, \{8, 0\}, \{0, 8, 1, 7\}, \{0, 3, 9\}, \{0, 7, 1, 9, \}, \dots, \{0, 1, 2, 3, 4, 5, \dots, 11\}\}$ .  $T_o^{M_5}$ ,  $T_\cup^{M_5}$  and  $T_\cap^{M_5}$  are subset set ideal semigroup topological subspaces of  $S$  relative to the subsemigroup  $B_5 = \{0, 1, 7\} \subseteq Z_{12}$ .

**Example 2.35:** Let

$S = \{\text{Collection of all subsets from the semigroup } Z_{10}, \times\}$  be the subset semigroup.  $T_o$ ,  $T_\cup$  and  $T_\cap$  be subset semigroup topological spaces of  $S$ .

Let  $P_1 = \{1, 9\} \subseteq Z_{20}$  be a semigroup of  $Z_{10}$ .

$\{\{0\}, \{1, 9\}, \{2, 8\}, \{3, 7\}, \{4, 6\}, \{5\}, \{0, 1, 9\}, \{0, 2, 8\}, \{0, 3, 7\}, \{0, 4, 6\}, \{0, 5\}, \{0, 1, 2, 8, 9\}, \{0, 1, 9, 5\}, \dots, \{0, 1, 2, 3, 4, 5, 6, 7, 8, 9\}\} = M_1$ , the collection of all subset set ideal semigroup over the subsemigroup  $P_1$ .

$T_o^{M_1}$ ,  $T_\cup^{M_1}$  and  $T_\cap^{M_1}$  be the subset set ideal semigroup topological spaces over the subsemigroup  $P_1 = \{1, 9\} \subseteq Z_{10}$ .

Take  $P_2 = \{0, 1, 9\} \subseteq Z_{10}$  be the subsemigroup  $M_2 = \{\text{Collection of all subset ideals of } S \text{ over the semigroup } P_2 = \{0, 1, 9\} \subseteq Z_{10}\} = \{\{0\}, \{0, 1, 9\}, \{0, 2, 8\}, \{0, 3, 7\}, \{0, 4, 6\}, \{0, 5\}, \{0, 1, 9, 2, 8\}, \{\{0, 2, 8, 1, 9\}, \{0, 5, 1, 9\}, \dots, \{0, 1, 2, 3, \dots, 9\}\} \subseteq S$ .

$T_o^{M_2}$ ,  $T_\cup^{M_2}$  and  $T_\cap^{M_2}$  are the subset set ideal semigroup topological spaces over the subsemigroup  $P_2$ .

It is clear  $T_o^{M_1} \neq T_o^{M_2}$  or  $T_\cup^{M_1} \neq T_\cup^{M_2}$  or  $T_\cap^{M_1} \neq T_\cap^{M_2}$ .

Take  $P_3 = \{6\} \subseteq Z_{10}$ , is a subsemigroup of  $Z_{10}$ .

Let  $M_3 = \{\text{Collection of all subset ideals of } S \text{ over the subsemigroup } P_3 = \{6\}\} = \{\{0\}, \{6\}, \{0, 6\}, \{1, 6\}, \{0, 1, 6\}, \{2\}, \{2, 0\}, \{0, 2, 1, 6\}, \{3, 8\}, \{1, 3, 8, 6\}, \{0, 3, 8\}, \{4\}, \{0,$

$4\}$ ,  $\{0, 1, 4, 6\}$ ,  $\{5, 0\}$ ,  $\{0, 5, 1, 6\}$ ,  $\{0, 5, 6\}$ , ...,  $\{0, 1, 2, \dots, 9\}$   $\} \subseteq S$ .

$T_o^{M_3}$ ,  $T_\cup^{M_3}$  and  $T_\cap^{M_3}$  are subset set ideal semigroup topological spaces related to the subsemigroup of  $Z_{12}$ .

Let  $M_4 = \{\text{Collection of all set subset ideal over the subsemigroup } P_4 = \{1, 6\} \subseteq Z_{12}\} = \{\{0\}, \{6\}, \{0, 6\}, \{1, 6\}, \{0, 1, 6\}, \{5, 0\}, \{0, 5, 6\}, \{0, 5, 6, 1\}, \dots, \{0, 1, 2, \dots, 9\}\} \subseteq S$ . Now  $T_o^{M_4}$ ,  $T_\cup^{M_4}$  and  $T_\cap^{M_4}$  are subset set ideal semigroup topological spaces over the subsemigroup  $\{1, 6\}$ .

We see  $T_o^{M_4}$ ,  $T_\cup^{M_4}$  and  $T_\cap^{M_4}$  are distinctly different from  $T_o^{M_3}$ ,  $T_\cup^{M_3}$  and  $T_\cap^{M_3}$  respectively.

It is pertinent to keep on record that we can have as many subset set ideal semigroup topological spaces as that of the number of subsemigroup in the semigroup. This is one of the advantages of using the notion of subset set ideal semigroup topological spaces.

**Example 2.36:** Let

$S = \{\text{Collection of all subsets form the semigroup } \{Z, \times\}\}$  be the subset semigroup.

Let  $T_o$ ,  $T_\cup$  and  $T_\cap$  be the subset semigroup topological spaces of  $S$ .

We have infinite number of subsemigroup in  $(Z, \times)$  hence we can have infinite number of set ideal subset semigroup topological spaces over these subsemigroup in  $(Z, \times)$ .

**Example 2.37:** Let  $S = \{\text{Collection of all subsets from the semigroup } P = \{(a_1, a_2, \dots, a_{10}) \mid a_i \in A_5, 1 \leq i \leq 10\}\}$  be the subset semigroup. Associated with  $S$  we have several subset set ideal topological semigroup spaces which are non commutative. Thus non commutative subset set ideal topological spaces can

be got using non commutative semigroups and their subsemigroups.

**Example 2.38:** Let  $S = \{\text{Collection of all subsets from the semigroup}\}$

$$P = \left\{ \left[ \begin{array}{c} a_1 \\ a_2 \\ a_3 \\ a_4 \\ a_5 \\ a_6 \end{array} \right] \mid a_i \in \mathbb{Z}; 1 \leq i \leq 6 \text{ under the natural product } \times_n \right\}$$

be the subset semigroup.  $T_\circ, T_\cup$  and  $T_\cap$  be the subset semigroup topological space.

$T_\circ^{P_i}, T_\cup^{P_i}$  and  $T_\cap^{P_i}$  be the subset set ideal semigroup topological space over the subsemigroup  $P_i, 1 \leq i \leq \infty$ . Thus we have infinite number of subset set ideal semigroup topological spaces relative to the subsemigroups of  $P$ .

Now having seen subset set ideal semigroup topological spaces we now proceed on to study and describe the topological spaces which are subset ideals.

Recall if  $Z_{12}$  is a semigroup under product, all subsemigroups of  $Z_{12}$  are not ideals, for  $P_1 = \{0, 1, 11\} \subseteq Z_{12}$  is a subsemigroup but is not an ideal of  $Z_{12}$ . The ideals of  $Z_{12}$  are  $\{0\} = I_1, I_2 = Z_{12}, I_3 = \{0, 2, 4, 6, 8, 10\}, \{0, 6\} = I_4, I_5 = \{0, 4, 8\}$  and  $I_6 = \{0, 3, 6, 9\}$  are the only ideals of  $Z_{12}$ .

We can give two operations on them  $\cup$  and  $\cap$ . Regarding  $\cap$  it is closed; we see  $\langle I_i \cup I_j \rangle$  is the ideal generated by the two ideals  $I_i$  and  $I_j$ .

Thus  $W = \{I_0, I_1, I_2, I_3, I_4, I_5, I_6 \text{ and so on}\} \subseteq S$  form a usual topological space under ' $\cup$ ' and ' $\cap$ '.

Now  $T_\cup = \{W, \cup, *\}$  and  $T_\cap = \{W', \cap, *\}$  are the other ideal subset topological spaces of  $S$  as  $W$  is basically a subset collection of  $S$ .

Now if we take  $I_6$  and  $I_5$  we see

$I_6 * I_5 = \{0, 4, 8\} * \{0, 3, 6, 9\} = \{0\}$  and  $I_6 \cap I_5 = \{0\}$  and  $I_6 \cup I_5 = \langle \{0, 4, 8, 3, 6, 9\} \rangle$  is an ideal of  $Z_{12}$ .

$I_5 \cup I_4 = \{0, 4, 8\} \cup \{0, 6\}$   
 $= \{0, 4, 8, 0, 6\}$  is again an ideal of  $Z_{12}$ .

Thus we have all the three topological spaces associated with ideals of  $Z_{12}$ .

Suppose we take  $(Z_6, \times)$  the ideals of  $Z_6$  are  $\{0, 3\}$ ,  $\{0\}$ ,  $\{0, 2, 4\}$ ,  $\{Z_6\}$ ,  $\langle 0, 2, 4, 3 \rangle$ . So  $M = \{\{0\}, \{0, 3\}, \{0, 2, 4\}, \langle 0, 2, 4, 3 \rangle, \{Z_6\}\} \subseteq S$  has topological structure relative to  $\cup, \cap$  so  $T_\cup$  usual space  $T_\cup$  and  $T_\cap$  associated special spaces.

The tree associated with  $M$  is

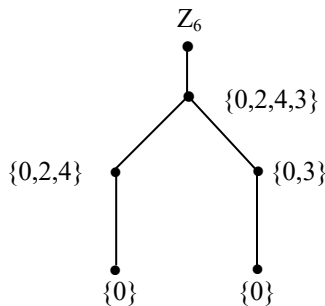

Let  $A = \{0, 2, 3, 4\}$  and  $B = \{0, 3\} \in M$ .

$$A \cup B = \{0, 2, 3, 4\} \cup \{0, 3\}$$

$$= \{0, 2, 4, 3\}.$$

$$\begin{aligned} A \cap B &= \{0, 2, 3, 4\} \cap \{0, 3\} \\ &= \{0, 3\}. \end{aligned}$$

$$\begin{aligned} A * B &= \{0, 2, 3, 4\} * \{0, 3\} \\ &= \{0, 3\}. \end{aligned}$$

Let  $A = \{0, 2, 4\}$  and  $B = \{0, 2, 4, 3\}$

$$\begin{aligned} A * B &= \{0, 2, 4\} * \{0, 2, 4, 3\} \\ &= \{0, 4, 2\} \text{ and} \end{aligned}$$

$$\begin{aligned} A \cap B &= \{0, 2, 4\} \cap \{0, 2, 4, 3\} \\ &= \{0, 2, 4\}. \end{aligned}$$

So in this subset semigroup of the semigroup  $Z_6$ .

We see  $T_0 = T_{\cup} = T_{\cap}$ .

Consider  $(Z_{12}, \times)$  the ideals of  $Z_{12}$  are  $M = \{\{0\}, Z_{12}, \{0, 6\}, \{0, 3, 6, 9\}, \{0, 4, 8\}, \{0, 2, 4, 6, 8, 10\}, \{0, 4, 6, 8\}, \{0, 3, 6, 9, 4, 8\}, \{0, 2, 4, 6, 8, 10, 3, 9\}\}$ .

Let  $A = \{0, 3, 6, 9\}$  and  
 $B = \{0, 4, 8\} \in M$ .

$A \cap B = \{0\}$ ,  $A \cup B = \{0, 3, 6, 9, 4, 8\}$  and  $A * B = \{0\}$ .

$A = \{0, 2, 6, 4, 8, 10\}$   
and  $B = \{0, 3, 6, 9\} \in M$

$A \cup B = \{0, 2, 3, 4, 6, 8, 9, 10\}$ .

$A \cap B = \{0, 6\}$ .

$A * B = \{0, 6\}$ .

Thus  $T_0^M = T_{\cup}^M = T_{\cap}^M$ .

Hence we leave it as an open problem whether if we take ideals of a subset semigroup; will  $T_o^M = T_{\cup}^M = T_{\cap}^M$ ; where M is the collection of all ideals of the semigroup (P, \*)?

Let  $S = \{\text{Collection of all subsets from the semigroup (P, } \times) = \{(a_1, a_2, a_3) \mid a_i \in Z_4, 1 \leq i \leq 3. \text{ be the subset semigroup.}$

The ideals of (P,  $\times$ ) are  $\{(0, 0, 0)\}, \{(0, 0, 0), (2, 2, 2)\} \{(0, 0, 0), (1, 1, 1), (2, 2, 2)\} \{(0, 0, 0), (2, 0, 0)\}, \{(0, 0, 0), (1, 1, 1), (2, 2, 2), (3, 3, 3)\}, \{(0, 0, 0), (0, 2, 0)\}, \{(0, 0, 0), (0, 0, 2)\} \{(0, 0, 0), (2, 2, 0)\} \{(0, 0, 0), (2, 0, 2)\}, \{(0, 0, 0), (0, 2, 2)\} \{(0, 0, 0), (1, 0, 0), (2, 0, 0), (3, 0, 0)\}$  and so on.

So we have a very large subset contributing for the subset topological space.

For instance if we take  $S = \{\text{Collection of all subsets from the semigroup (P, } \times) = \left\{ \begin{bmatrix} a_1 \\ a_2 \end{bmatrix} \mid a_1, a_2 \in Z_3 \right\}$ .

The ideals of P are

$$\left\{ \begin{bmatrix} 0 \\ 0 \end{bmatrix} \right\}, \left\{ \begin{bmatrix} 0 \\ 0 \end{bmatrix}, \begin{bmatrix} 1 \\ 1 \end{bmatrix}, \begin{bmatrix} 2 \\ 2 \end{bmatrix} \right\}, \left\{ \begin{bmatrix} 0 \\ 0 \end{bmatrix}, \begin{bmatrix} 1 \\ 0 \end{bmatrix}, \begin{bmatrix} 2 \\ 0 \end{bmatrix} \right\}, \left\{ \begin{bmatrix} 0 \\ 0 \end{bmatrix}, \begin{bmatrix} 0 \\ 1 \end{bmatrix}, \begin{bmatrix} 0 \\ 2 \end{bmatrix} \right\},$$

$$\left\{ \begin{bmatrix} 0 \\ 0 \end{bmatrix}, \begin{bmatrix} 1 \\ 2 \end{bmatrix}, \begin{bmatrix} 2 \\ 1 \end{bmatrix}, \begin{bmatrix} 1 \\ 1 \end{bmatrix}, \begin{bmatrix} 2 \\ 2 \end{bmatrix} \right\} \text{ and}$$

$$\left\{ \begin{bmatrix} 0 \\ 0 \end{bmatrix}, \begin{bmatrix} 1 \\ 2 \end{bmatrix}, \begin{bmatrix} 2 \\ 1 \end{bmatrix}, \begin{bmatrix} 1 \\ 1 \end{bmatrix}, \begin{bmatrix} 2 \\ 2 \end{bmatrix}, \begin{bmatrix} 0 \\ 1 \end{bmatrix}, \begin{bmatrix} 0 \\ 2 \end{bmatrix}, \begin{bmatrix} 2 \\ 0 \end{bmatrix}, \begin{bmatrix} 1 \\ 0 \end{bmatrix} \right\}.$$

$$\text{Now } A = \left\{ \begin{bmatrix} 0 \\ 0 \end{bmatrix}, \begin{bmatrix} 1 \\ 1 \end{bmatrix}, \begin{bmatrix} 2 \\ 2 \end{bmatrix} \right\} \text{ and } B = \left\{ \begin{bmatrix} 0 \\ 0 \end{bmatrix}, \begin{bmatrix} 1 \\ 0 \end{bmatrix}, \begin{bmatrix} 2 \\ 0 \end{bmatrix} \right\}$$

$$A \cup B = \left\langle \left\{ \begin{bmatrix} 0 \\ 0 \end{bmatrix}, \begin{bmatrix} 1 \\ 1 \end{bmatrix}, \begin{bmatrix} 2 \\ 2 \end{bmatrix}, \begin{bmatrix} 0 \\ 0 \end{bmatrix}, \begin{bmatrix} 1 \\ 0 \end{bmatrix}, \begin{bmatrix} 2 \\ 0 \end{bmatrix} \right\} \right\rangle \text{ and}$$

$$A \cap B = \left\{ \begin{bmatrix} 0 \\ 0 \end{bmatrix} \right\}.$$

$$\begin{aligned} A * B &= \left\{ \begin{bmatrix} 0 \\ 0 \end{bmatrix}, \begin{bmatrix} 1 \\ 1 \end{bmatrix}, \begin{bmatrix} 2 \\ 2 \end{bmatrix} \right\} * \left\{ \begin{bmatrix} 0 \\ 0 \end{bmatrix}, \begin{bmatrix} 1 \\ 0 \end{bmatrix}, \begin{bmatrix} 2 \\ 0 \end{bmatrix} \right\} \\ &= \left\{ \begin{bmatrix} 0 \\ 0 \end{bmatrix}, \begin{bmatrix} 1 \\ 0 \end{bmatrix}, \begin{bmatrix} 2 \\ 0 \end{bmatrix} \right\}. \end{aligned}$$

$$A * B \neq A \cap B.$$

Further  $A \cup B$  is not an ideal only  $\langle A \cup B \rangle$  generated as an ideal is an ideal.

Thus we see in all case the three subset ideal topological semigroup spaces  $T_o^I$ ,  $T_{\cup}^I$  and  $T_{\cap}^I$  need not be identical. This is more so when the semigroup is constructed using a field like  $Z_3$  and so on.

Let  $(P, *) = \{(a_1, a_2, a_3) \mid a_i \in Z_3, 1 \leq i \leq 3\}$  be the semigroup  
 $S = \{\text{Collection of all subsets form the semigroup } (P, *)\}$  be the subset semigroup. The ideals of  $(P, *)$  are  $M = \{(0, 0, 0)\}$

$\{(0, 0, 0), (2, 2, 0), (1, 1, 1), (1, 1, 0), (2, 2, 2), (0, 0, 1), (0, 0, 2), (1, 0, 2), (2, 0, 2), (1, 0, 1), (2, 0, 1), (1, 0, 1)\}$ ,  $\{(0, 0, 0), (1, 0, 0), (2, 0, 0)\}$ ,  $\{(0, 0, 0), (0, 1, 0), (0, 2, 0)\}$ ,  $\{(0, 0, 0), (0, 0, 1), (0, 0, 2)\}$ ,  $\{(0, 0, 0), (1, 1, 0), (1, 0, 0), (0, 1, 0), (0, 2, 0), (2, 0, 0), (2, 2, 0)\}$ ,  $\{(0, 0, 0), (0, 0, 1), (0, 1, 1), (0, 1, 0), (0, 2, 2), (0, 2, 0), (0, 0, 2), (0, 2, 2)\}$   $\{(0, 0, 0), (2, 0, 0), (0, 0, 2), (0,$



$0, 1), (1, 0, 1), (1, 0, 0), (2, 0, 2)\}$  ,  $\{(0, 0, 0), (1, 0, 2), (2, 0, 1)\}$  and so on.

Several ideals of  $(P, *)$  are got and  $T_{\cup}^I \neq T_{\cap}^I$  or  $T_{\cup}^I \neq T_S^I$  or  $T_{\cap}^I \neq T_S^I$ .

Thus it is easily verified we get subset ideal topological semigroup spaces  $T_o^I$ ,  $T_{\cup}^I$  and  $T_{\cap}^I$ .

Study in this direction is very innovative and interesting for we see in certain semigroups  $T_o^I = T_{\cup}^I = T_{\cap}^I$  in certain cases  $T_o^I$ ,  $T_{\cup}^I$  and  $T_{\cap}^I$  are distinct. So it is an open problem to characterize those semigroups for which  $T_{\cup}^I = T_{\cap}^I = T_o^I$ . Also when will  $A \cap B = A * B$  for all  $A, B \in S$ .

We suggest the following problems for this chapter.

**Problems:**

1. Find some special features enjoyed by subset semigroup topological spaces  $T_o$ ,  $T_{\cup}$  and  $T_{\cap}$  of a subset semigroup  $S$  of finite order.
2. Suppose  $S$  is a subset semigroup of finite order find the trees associated with the subset topological semigroup spaces  $T_o$ ,  $T_{\cup}$  and  $T_{\cap}$ .
  - (i) Are the three trees associated with  $T_o$ ,  $T_{\cup}$  and  $T_{\cap}$  distinct or the same?
  - (ii) Can all the three trees associated with  $T_o$ ,  $T_{\cup}$  and  $T_{\cap}$  be identical? Justify your claim.
3. Let  $S = \{\text{Collection of all subsets from the semigroup } S(3)\}$  be the subset semigroup.

- (i) Find  $o(S)$ .
- (ii) Show  $T_{\cup}$  and  $T_{\cap}$ , the subset semigroup topological spaces are non commutative and are of finite order.
- (iii) Find all subset semigroup topological subspaces of  $T_{\circ}$ ,  $T_{\cup}$  and  $T_{\cap}$  which are commutative.
- (iv) Find all subset semigroup topological subspaces of  $T_{\cup}$  and  $T_{\cap}$ .

4. Let  $S_1 = \{\text{Collection of all subsets from the semigroup } P = \{(a_1, a_2, a_3, a_4, a_5, a_6) \mid a_i \in \mathbb{Z}_{20}, \times; 1 \leq i \leq 6\}\}$  be the subset semigroup.

- (i) Study questions (i) and (iii) of problem 4 for this  $S_1$ .
- (ii) Prove  $T_{\cup}$  and  $T_{\cap}$  contain subset topological semigroup zero divisors.
- (iii) Is  $T_{\circ}$ ,  $T_{\cup}$  and  $T_{\cap}$  Smarandache subset semigroup topological spaces?

5. Let  $S_2 = \{\text{Collection of all subsets from the matrix}$

$$\text{semigroup } P \text{ under natural product } \times_n; P = \left\{ \begin{array}{cc} a_1 & a_2 \\ a_3 & a_4 \\ a_5 & a_6 \\ a_7 & a_8 \\ a_9 & a_{10} \\ a_{11} & a_{12} \end{array} \right\}$$

$a_i \in \mathbb{Z}_6 \times \mathbb{Z}_{10}; 1 \leq i \leq 12\}$  be the subset semigroup.

Study questions (i) and (iii) of problem 4 for this  $S_2$ .

6. Let  $S = \{\text{Collection of all subsets of the semigroup } P = (\mathbb{Z}_{24}, \times)\}$  be the subset semigroup.

- (i) Find all subsemigroups  $M_i$  of  $P$ .
- (ii) Find all subset set ideal topological semigroup subspaces  $T_0^{M_i}$ ,  $T_{\cup}^{M_i}$  and  $T_{\cap}^{M_i}$  over the subsemigroup  $M_i$ .
- (iii) Find  $o(S)$ .

7. Let  $S = \{\text{Collection of all subsets from the semigroup } C(\mathbb{Z}_{24})\}$  be the subset semigroup.

Study questions (i) to (iii) of problem 6 for this  $S$ .

8. Let  $S = \{\text{Collection of all subsets from the semigroup } C(\langle \mathbb{Z}_{19} \cup I \rangle)\}$  be the subset semigroup.

Study questions (i) to (iii) of problem 6 for this  $S$ .

9. Let  $S = \{\text{Collection of all subsets from the semigroup}$

$$M = \left\{ \left[ \begin{array}{cc} a_1 & a_2 \\ a_3 & a_4 \end{array} \right] \mid a_i \in A_4, 1 \leq i \leq 4 \right\} \text{ under the natural}$$

product  $\times_n$ .

Study questions (i) to (iii) of problem 6 for this  $S$ .

10. Let  $S_2 = \{\text{Collection of all subsets from the matrix}$

$$\text{semigroup } (P, \times_n) = \left\{ \left[ \begin{array}{c} a_1 \\ a_2 \\ a_3 \\ a_4 \\ a_5 \\ a_6 \\ a_7 \end{array} \right] \mid a_i \in \mathbb{Z}_{10} \times \mathbb{Z}_{15}, 1 \leq i \leq 7 \right\} \text{ be}$$

the subset semigroup.

Study questions (i) to (iii) of problem 6 for this  $S_2$ .

11. Let  $S = \{\text{Collection of all subsets from the semigroup}$

$$(M, \times_n) = \left\{ \left[ \begin{array}{cccc} a_1 & a_2 & \dots & a_7 \\ a_8 & a_9 & \dots & a_{14} \end{array} \right] \mid a_i \in C(\langle Z_8 \cup I \rangle), \right.$$

$1 \leq i \leq 14 \} \}$  be the subset semigroup.

Study questions (i) to (iii) of problem 6 for this  $S$ .

12. Let  $S = \{\text{Collection of all subsets from the semigroup}$

$$(M, \times_n) = \left\{ \left[ \begin{array}{cccc} a_1 & a_2 & a_3 & a_4 \\ a_5 & a_6 & a_7 & a_8 \\ a_9 & a_{10} & a_{11} & a_{12} \\ a_{13} & a_{14} & a_{15} & a_{16} \\ a_{17} & a_{18} & a_{19} & a_{20} \end{array} \right] \mid a_i \in D_{2,7} \times A_5; \right.$$

$1 \leq i \leq 20, \times_n \} \}$  be the subset semigroup.

Study questions (i) to (iii) of problem 6 for this  $S$ .

13. Enumerate any of the interesting properties associated with subset set ideal semigroup topological spaces of  $T_0^M$ ,  $T_{\cup}^M$  and  $T_{\cap}^M$ .
14. Enumerate and differentiate between  $T_{\cup}^M$  and  $T_{\cap}^M$  for any non commutative subset semigroup of finite order.

15. Let  $S = \{\text{Collection of all subsets from the semigroup}$

$$(P, *) = \left\{ \left[ \begin{array}{cc} a_1 & a_2 \\ a_3 & a_4 \\ \vdots & \vdots \\ a_{19} & a_{20} \end{array} \right] \mid a_i \in \mathbb{Z}_{48}, \times_n; 1 \leq i \leq 20 \right\}$$

be the subset semigroup.

- (i) Find  $o(S)$ .
- (ii) Find all subset semigroup topological spaces  $T_o$ ,  $T_\cup$  and  $T_\cap$ .
- (iii) Find the subset semigroup topological subspaces of  $T_o$ ,  $T_\cup$  and  $T_\cap$ .
- (iv) Prove  $T_\cup$  and  $T_\cap$  has subset semigroup topological zero divisors.
- (v) Find all subsemigroups of  $(P, *)$ .
- (vi) Find corresponding to each of the subsemigroup  $P_i$  the subset set ideal semigroup topological spaces  $T_o^{P_i}$ ,  $T_\cup^{P_i}$  and  $T_\cap^{P_i}$ .
- (vii) Can  $T_\cup$  (and  $T_\cap$ ) have subspaces  $W_i$  and  $W_j$  such

$$\text{that } W_i \times W_j = \left\{ \left[ \begin{array}{cc} 0 & 0 \\ 0 & 0 \\ \vdots & \vdots \\ 0 & 0 \end{array} \right] \right\} ?$$

16. Describe the special features enjoyed by Smarandache subset semigroup topological spaces  $T_o$ ,  $T_{\cup}$  and  $T_{\cap}$ .
17. Let  $S = \{\text{Collection of all subsets from the semigroup}$

$$(P, *) = \left\{ \left[ \begin{array}{c} a_1 \\ a_2 \\ a_3 \\ a_4 \\ a_5 \end{array} \right] \mid a_i \in (Z_5, *); 1 \leq i \leq 6 \right\} \text{ be the subset}$$

semigroup (\* is the  $\times_n \text{ mod } 5$ ).

- (i) Find all ideals of the semigroup  $(P, *)$ .
- (ii) Using the collection of ideals  $M$  of the semigroup  $(P, *)$  find  $T_o^M$ ,  $T_{\cup}^M$  and  $T_{\cap}^M$ .
- (iii) Is  $T_{\cup}^M \neq T_o^M$ , and  $T_{\cap}^M \neq T_o^M$  and  $T_{\cup}^M \neq T_{\cap}^M$ ?
- (iv) Find  $o(T_{\cup}^M)$ .
- (v) Compare  $T_{\cup}^M$  with  $T_{\cup}$ ,  $T_{\cap}^M$  with  $T_{\cap}$  and  $T_o^M$  with  $T_o$ .
- (vi) Find all subset semigroup topological zero divisors.
- (vii) Is  $S$  a Smarandache semigroup?
- (viii) Is  $T_{\cup}^M$ ,  $T_{\cap}^M$  and  $T_o^M$   $S$ -subset ideal semigroup topological spaces?
- (ix) Find all subsemigroups of  $(P, *)$ .

- (x) Find all subset set ideal semigroup topological spaces over these subsemigroups.

18. Let  $S = \{\text{Collection of all subsets from the semigroup}$

$$(P, *) = \left\{ \left[ \begin{array}{cc} a_1 & a_2 \\ a_3 & a_4 \\ a_5 & a_6 \\ a_7 & a_8 \\ a_9 & a_{10} \end{array} \right] \mid a_i \in Z_{13}, *; 1 \leq i \leq 10 \right\}$$

be the subset semigroup.

Study questions (i) to (x) of problem 17 for this S.

19. Let  $S = \{\text{Collection of all subsets from the semigroup}$

$$(P, *) = \left\{ \left[ \begin{array}{cccc} a_1 & a_2 & \dots & a_{10} \\ a_{11} & a_{12} & \dots & a_{20} \\ a_{21} & a_{22} & \dots & a_{30} \end{array} \right] \mid a_i \in Z_{16}, *; 1 \leq i \leq 30 \right\}$$

be the subset semigroup.

Study questions (i) to (x) of problem 17 for this S.

20. Let  $S = \{\text{Collection of all subsets from the semigroup}$

$$(P, *) = \left\{ \left[ \begin{array}{c} a_1 \\ a_2 \\ a_3 \\ \vdots \\ a_{10} \end{array} \right] \mid a_i \in Z_{15} \times_n Z_{24}; 1 \leq i \leq 10 \right\}$$

be the subset semigroup.

Study questions (i) to (x) of problem 17 for this S.

21. Let  $S = \{\text{Collection of all subsets from the semigroup}$

$$P = \left\{ \left[ \begin{array}{cccc} a_1 & a_2 & a_3 & a_4 \\ a_5 & a_6 & a_7 & a_8 \\ a_9 & a_{10} & a_{11} & a_{12} \\ a_{13} & a_{14} & a_{15} & a_{16} \end{array} \right] \mid a_i \in Z_8(S(4)) \text{ under } \times_n, \right.$$

$1 \leq i \leq 16\} \}$  be the subset semigroup.

Study questions (i) to (x) of problem 17 for this S.

22. Let  $S = \{\text{Collection of all subsets form the semigroup}$

$$P = \left\{ \sum_{i=0}^{20} a_i x^i \mid x^{21} = 1, a_i \in Z_{14} \times Z_{25}, 0 \leq i \leq 20 \right\}$$

be the subset semigroup.

Study questions (i) to (x) of problem 17 for this S.

23. Let  $S = \{\text{Collection of all subsets form the semigroup}$   
 $P = \{(a_1, a_2, \dots, a_7) \mid a_i \in C(Z_{30}) \ 1 \leq i \leq 7\}$  be the subset semigroup.

Study questions (i) to (x) of problem 17 for this S.

24. Let  $S = \{\text{Collection of all subsets from the semigroup}$

$$(P, *) = \left\{ \left[ \begin{array}{cccc} a_1 & a_2 & \dots & a_7 \\ a_8 & a_9 & \dots & a_{14} \\ a_{15} & a_{16} & \dots & a_{21} \\ a_{22} & a_{23} & \dots & a_{28} \\ a_{29} & a_{30} & \dots & a_{35} \end{array} \right] \mid a_i \in C(Z_{24}) \times C(Z_{11}); \right.$$



$1 \leq i \leq 35\}$  be the subset semigroup.

Study questions (i) to (x) of problem 17 for this S.

25. Let  $S = \{\text{Collection of all subsets from the semigroup}$

$$(P, *) = \left\{ \left[ \begin{array}{cccc} a_1 & a_2 & \dots & a_{10} \\ a_{11} & a_{12} & \dots & a_{20} \end{array} \right] \mid a_i \in C(\mathbb{Z}_{43}); 1 \leq i \leq 20 \right\}$$

be the subset semigroup.

Study questions (i) to (x) of problem 17 for this S.

26. Let  $S = \{\text{Collection of all subsets from the semigroup } (P, *) = (\mathbb{Z}^+ \cup \{0\}) S_3\}$  be the subset semigroup.

Study questions (i) to (x) of problem 17 for this S.

27. Let  $S = \{\text{Collection of all subsets from the semigroup } (P, *) = (\mathbb{R}^+ \cup \{0\}) D_{2,7} \times S_7\}$  be the subset semigroup.

Study questions (i) to (x) of problem 17 for this S.

28. Let  $S = \{\text{Collection of all subsets from the semigroup } (P, *) = (\mathbb{Z}^+ \cup \{0\}) S(5)\}$  be the subset semigroup.

Study questions (i) to (x) of problem 17 for this S.

29. Let  $S = \{\text{Collection of all subsets from the semigroup } (P, *) = (\mathbb{Z}^+ \cup \{0\}) S_3 \times D_{2,7}\}$  be the subset semigroup.

Study questions (i) to (x) of problem 17 for this S.

30. Let  $S = \{\text{Collection of all subsets from the semigroup}$

$$(P, *) = \left\{ \left[ \begin{array}{ccc} a_1 & a_2 & a_3 \\ a_4 & a_5 & a_6 \\ a_7 & a_8 & a_9 \\ a_{10} & a_{11} & a_{12} \\ a_{13} & a_{14} & a_{15} \end{array} \right] \mid a_i \in Z^+ \cup \{0\} \right\} S_7 \times D_{2,5},$$

$1 \leq i \leq 15\}$  be the subset semigroup.

Study questions (i) to (x) of problem 17 for this S.

31. Let  $S = \{\text{Collection of all subsets from the semigroup}$

$$(P, *) = \left\{ \left[ \begin{array}{ccc} a_1 & a_2 & a_3 \\ a_4 & a_5 & a_6 \\ a_7 & a_8 & a_9 \\ a_{10} & a_{11} & a_{12} \\ a_{13} & a_{14} & a_{15} \\ a_{16} & a_{17} & a_{18} \\ a_{19} & a_{20} & a_{21} \end{array} \right] \mid a_i \in Z^+ \cup \{0\} \right\} S_9, 1 \leq i \leq 21\}$$

be the subset semigroup.

Study questions (i) to (x) of problem 17 for this S.

32. Let  $S = \{\text{Collection of all subsets from the semigroup}$   
 $(P, *) = (M, *) = (Q^+ \cup \{0\}) \times Z^+ \cup \{0\} (S_3 \times Z_{2,9}), 1 \leq i$   
 $\leq 18\}$  be the subset semigroup.

Study questions (i) to (x) of problem 17 for this S.

33. Let  $S = \{\text{Collection of all subsets from the semigroup}$   
 $(Z_{20}, +)\}$  be the subset semigroup.

Study questions (i) to (x) of problem 17 for this S.

Does S have any special features when a group is used instead of a semigroup?

34. Let  $S = \{\text{Collection of all subsets from the semigroup } S_3 \times D_{2,7}\}$  be the subset semigroup.

(i) Study questions (i) to (x) of problem 11 for this S.

35. Distinguish between subset semigroups when semigroup is used and when a group is used.

36. Let  $S = \{\text{Collection of all subsets from the semigroups } S(5) \times (Z_{20}, \times)\}$  be the subset semigroup.

Can we see S is a S-subset semigroup?

What are the special features enjoyed by the topological spaces by using S-subset semigroup?

37. Let  $S = \{\text{Collection of all subsets from the semigroup } M = \{(a_1, \dots, a_9) | a_i \in S_7, 1 \leq i \leq 9\}\}$  be the subset semigroup.

(i) Study questions (i) to (x) of problem 11 for this S.

38. Let  $S = \{\text{Collection of all subsets from the semigroup}$

$$M = \left\{ \left[ \begin{array}{cccc} a_1 & a_2 & \dots & a_6 \\ a_7 & a_8 & \dots & a_{12} \\ a_{13} & a_{14} & \dots & a_{18} \\ a_{19} & a_{20} & \dots & a_{24} \\ a_{25} & a_{26} & \dots & a_{30} \end{array} \right] \mid a_i \in D_{2,9}, S_{12}, 1 \leq i \leq 30 \right\} \text{ be}$$

the subset semigroup.

(i) Study questions (i) to (x) of problem 17 for this S.

39. Let  $S = \{\text{Collection of all subsets from the semigroup}$

$$M = \left\{ \left[ \begin{array}{c} a_1 \\ a_2 \\ \vdots \\ a_9 \end{array} \right] \mid a_i \in \mathbb{ZS}_7, 1 \leq i \leq 9 \right\}$$

be the subset semigroup.

(i) Enumerate all the special features enjoyed by S.

## Chapter Three

# SPECIAL TYPE OF SUBSET TOPOLOGICAL SPACES USING SEMIRINGS AND RINGS

In this chapter for the first time we introduce the notion of different types of subset topological spaces using semirings (or rings). However subsets of a ring have only the algebraic structure which can maximum be a subset semifield or a subset semiring. When we use rings to get subset semiring / semifield we call them as subset semiring of type I.

Let  $R$  be a ring,  $S$  the collection of all subsets from  $R$ .  $S$  is the subset semiring of type I.

We give examples of them.

**Example 3.1:** Let  $S = \{\text{Collection of all subsets from the ring } Z_{12}\}$  be the subset semiring of type I.

**Example 3.2:** Let  $S = \{\text{Collection of all subsets from the ring } Z_5S_5\}$  be the subset semiring of type I.  $S$  is non commutative.

**Example 3.3:** Let

$S = \{\text{Collection of all subsets from the ring } Z_{15} \times Z_{36}\}$  be the subset semiring of type I.

**Example 3.4:** Let

$S = \{\text{Collection of all subsets from the ring } Z_{15} (S_3 \times D_{2,7})\}$  be the subset semiring of type I.  $S$  is non commutative but of finite order.

**Example 3.5:** Let  $S = \{\text{Collection of all subsets from the ring } R\}$  be the commutative subset semiring of infinite order.

**Example 3.6:** Let

$S = \{\text{Collection of all subsets from the ring } ZS_7\}$  be the subset semiring of infinite order and is non commutative.

**Example 3.7:** Let

$S = \{\text{Collection of all subsets from the ring } Z(S(3) \times D_{2,5})\}$  be the subset semiring of type I of infinite order which is non commutative.

**Example 3.8:** Let  $S = \{\text{Collection of all subsets from the ring } M = \{(a_1, a_2, \dots, a_{10}) \mid a_i \in ZS_6\} \ 1 \leq i \leq 10\}$  be the subset semiring of type I which is non commutative has zero divisors.

**Example 3.9:** Let  $S = \{\text{Collection of all subsets from the ring}$

$$M = \left\{ \left[ \begin{array}{c} a_1 \\ a_2 \\ a_3 \\ a_4 \\ a_5 \\ a_6 \end{array} \right] \mid a_i \in Z_8S_7; 1 \leq i \leq 6 \right\}$$

be the subset semiring of type I which is non commutative of finite order.

**Example 3.10:** Let

$S = \{\text{Collection of all subsets from the ring } ZS(5)\}$  be the subset semiring of type I.  $S$  is non commutative and of infinite order.

**Example 3.11:** Let  $S = \{\text{Collection of all subsets from the ring}$

$$(M, \times_n) = \left\{ \left[ \begin{array}{ccccc} a_1 & a_2 & a_3 & a_4 & a_5 \\ a_6 & a_7 & a_8 & a_9 & a_{10} \\ a_{11} & a_{12} & a_{13} & a_{14} & a_{15} \end{array} \right] \middle| a_i \in Z_{12}S(3); \right. \\ \left. 1 \leq i \leq 15 \right\}$$

be the subset semiring of type I of finite order which is non commutative.

**Example 3.12:** Let  $S = \{\text{Collection of all subsets from the ring}$

$$M = \left\{ \left( \begin{array}{cc} a_1 & a_2 \\ a_3 & a_4 \end{array} \right) \middle| a_i \in Z_{36}(S_3 \times D_{2,11}); 1 \leq i \leq 4 \right\}$$

be the subset semiring of type I of finite order and is non commutative.

**Example 3.13:** Let  $S = \{\text{Collection of all subsets from the ring } \langle R \cup I \rangle (g) \text{ where } g^2 = 0\}$  be the subset semiring type I of infinite order and commutative.

**Example 3.14:** Let  $S = \{\text{Collection of all subsets from the ring } C(Z_{10}) (g_1, g_2, g_3) \text{ where } g_1^2 = 0, g_2^2 = g_2, g_3^2 = -g_3; g_i g_j = g_j g_i = 0; 1 \leq i, j \leq 3, i \neq j\}$  be the subset semiring of type I of finite order .

**Example 3.15:** Let  $S = \{\text{Collection of all subsets from the ring}$

$$M = \left\{ \begin{bmatrix} a_1 & a_2 \\ a_3 & a_4 \\ a_5 & a_6 \\ a_7 & a_8 \\ a_9 & a_{10} \end{bmatrix} \mid a_i \in C(\langle Z_5 \cup I \rangle S_7; 1 \leq i \leq 10) \right\}$$

be the subset semiring of type I of finite order which is non commutative.

**Example 3.16:** Let  $S = \{\text{Collection of all subsets from the ring.}$

$$P = \left\{ \sum_{i=0}^{\infty} a_i x^i \mid a_i \in C(\langle Z_{10} \cup I \rangle (D_{2,9} \times S(4))) \right\}$$

be the subset semiring of type I of infinite order which is non commutative.

**Example 3.17:** Let  $S = \{\text{Collection of all subsets from the ring}$

$$M = \left\{ \sum_{i=0}^{\infty} a_i x^i \mid a_i \in \langle Z \cup I \rangle S_3 \right\}$$

be the subset semiring of type I of infinite order which is non commutative.

**Example 3.18:** Let  $S = \{\text{Collection of all subsets from the ring}$

$$N = \left\{ \sum_{i=0}^{\infty} a_i x^i \mid a_i \in Z_4 \times Z_3 \times Z_7 \right\}$$

be the subset semiring of type I of infinite order.



Now we just define the possible types of subset semiring topological spaces of type I.

We will first denote by an example, then define.

**Example 3.19:** Let

$S = \{\text{Collection of all subsets from the ring } Z\}$  be the subset semiring of type I.  $T_o, T_{\cup}^+, T_{\cup}^{\times}, T_{\cap}^+, T_{\cap}^{\times}$  and  $T_s$  where

$$T_o = \{S' = S \cup \{\phi\}, \cup, \cap\}, T_{\cup}^+ = \{S, \cup, +\}, T_{\cap}^+ = \{S' = S \cup \{\phi\}, \cap, +\}$$

$$T_{\cup}^{\times} = \{S, \cup, \times\}, T_{\cap}^{\times} = \{S' \cap, \times\} \text{ and } T_s = \{S, \times, +\}.$$

We will test whether all the six topological subset semiring spaces are distinct are identical.

Take  $A = \{4, 6, 5, 7, 1\}$  and  $B = \{3, 2, 0, 18, 6, 5\} \in T_o$ .

$$\begin{aligned} A \cup B &= \{4, 6, 5, 7, 1\} \cup \{3, 2, 0, 18, 6, 5\} \\ &= \{4, 6, 5, 7, 1, 0, 18, 3, 2\} \text{ and} \end{aligned}$$

$$\begin{aligned} A \cap B &= \{4, 6, 5, 7, 1\} \cap \{3, 2, 0, 18, 6, 5\} \\ &= \{6, 5\} \text{ are in } T_o. \end{aligned}$$

Let  $A, B \in T_{\cup}^+ = \{S, \cup, +\}$ .

$$\begin{aligned} A \cup B &= \{4, 6, 5, 7, 1\} \cup \{3, 2, 0, 18, 6, 5\} \\ &= \{4, 6, 5, 7, 1, 0, 18, 3, 2\} \text{ and} \end{aligned}$$

$$\begin{aligned} A + B &= \{4, 6, 5, 7, 1\} + \{3, 2, 0, 18, 6, 5\} \\ &= \{4, 6, 5, 7, 1, 9, 8, 0, 22, 24, 23, 25, 19, 10, 12, \\ &\quad 11, 13\} \text{ are in } T_{\cup}^+. \end{aligned}$$

We see  $T_o$  and  $T_{\cup}^+$  are distinct as ring subset semiring topological spaces.

Consider  $A, B \in T_{\cup}^{\times}$ .

$$\begin{aligned} A \cup B &= \{4, 6, 5, 7, 1\} \cup \{3, 2, 0, 18, 6, 5\} \\ &= \{4, 6, 5, 7, 1, 3, 2, 0, 18\} \end{aligned}$$

$$\begin{aligned} A + B &= \{4, 6, 5, 7, 1\} \times \{3, 2, 0, 18, 6, 5\} \\ &= \{0, 8, 12, 18, 15, 21, 3, 10, 14, 2, 72, 108, 90, \\ &\quad 126, 18, 24, 36, 30, 42, 6, 20, 35, 5\} \text{ are in } T_{\cup}^{\times}. \end{aligned}$$

Clearly  $T_{\cup}^{\times}$  is different from the two subset ring topological semiring spaces  $T_0$  and  $T_{\cup}^{+}$ .

Now consider  $A, B \in T_{\cap}^{+} = \{S', \cap, +\}$ .

$$A \cap B = \{6, 5\} \text{ and}$$

$$\begin{aligned} A + B &= \{5, 4, 6, 7, 1, 9, 8, 0, 22, 24, 23, 25, 19, 10, 12, \\ &\quad 11, 13\} \text{ are in } T_{\cap}^{+}. \end{aligned}$$

Thus  $T_{\cap}^{+}$  is different from  $T_{\cup}^{+}$ ,  $T_{\cup}^{\times}$  and  $T_0$  as topological spaces.

Consider  $A, B \in T_{\cap}^{\times} = \{S', \cap, \times\}$

$$A \cap B = \{6, 5\} \text{ and } A \times B = \{0, 8, 12, 18, 15, 21, 3, 10, 14, 2, 72, 108, 90, 126, 18, 24, 36, 30, 42, 6, 20, 35, 5\} \in T_{\cap}^{\times}.$$

We see  $T_{\cap}^{\times}$  is distinct from  $T_{\cup}^{\times}$ ,  $T_{\cup}^{+}$ ,  $T_{\cap}^{+}$  and  $T_0$  as subset ring semiring topological spaces.

Finally let  $A, B \in T_s = \{S, +, \times\}$ .

$A + B$  and  $A \times B$  are given above. Clearly  $T_s$  is different from the subset ring semiring topological spaces  $T_0$ ,  $T_{\cup}^{+}$ ,  $T_{\cup}^{\times}$ ,  $T_{\cap}^{\times}$  and  $T_{\cap}^{+}$ .

**Example 3.20:** Let

$S = \{\text{Collection of all subsets from the ring } Z_{10}\}$  be the subset semiring of type I. Let  $T_o$ ,  $T_{\cup}^+$ ,  $T_{\cup}^{\times}$ ,  $T_{\cap}^+$ ,  $T_{\cap}^{\times}$  and  $T_s$  be subset ring semiring topological spaces of  $S$ .

Let  $A, B \in T_o = \{S, \cup, \cap\}$  where

$$A = \{2, 5, 6, 3\} \text{ and } B = \{5, 0, 1, 8, 7\} \in T_o.$$

$$\begin{aligned} A \cup B &= \{2, 5, 6, 3\} \cup \{5, 0, 1, 8, 7\} \\ &= \{2, 5, 6, 3, 0, 1, 8, 7\} \text{ and} \end{aligned}$$

$$\begin{aligned} A \cap B &= \{2, 5, 6, 3\} \cap \{5, 0, 1, 8, 7\} \\ &= \{5\} \text{ are in } T_o. \end{aligned}$$

Let  $A, B \in T_{\cup}^+$ ;

$$\begin{aligned} A + B &= \{2, 5, 6, 3\} + \{5, 0, 1, 8, 7\} \\ &= \{2, 5, 6, 3, 7, 0, 1, 8, 4, 9\} \text{ and} \end{aligned}$$

$$\begin{aligned} A \cup B &= \{2, 5, 6, 3\} \cup \{5, 0, 1, 8, 7\} \\ &= \{1, 2, 5, 6, 3, 8, 7, 0\} \text{ are in } T_{\cup}^+. \end{aligned}$$

We have  $T_o$  is different from the subset ring semiring topological space  $T_{\cup}^+$ .

Let  $A, B \in T_{\cup}^{\times}$ ;

$$\begin{aligned} A \cup B &= \{2, 5, 6, 3\} \cup \{5, 0, 1, 8, 7\} \\ &= \{0, 1, 2, 3, 4, 5, 6, 7, 8\} \text{ and} \end{aligned}$$

$$\begin{aligned} A \times B &= \{2, 5, 6, 3\} \times \{5, 0, 1, 8, 7\} \\ &= \{0, 5, 2, 6, 3, 8, 4, 1\} \text{ are in } T_{\cup}^{\times}. \end{aligned}$$

$T_{\cup}^{\times}$  is different from  $T_{\cup}^+$  and  $T_o$  as subset semiring ring topological spaces.

Let  $A, B \in T_{\cap}^+$ ;

$$A \cap B = \{2, 5, 6, 3\} \cap \{5, 0, 1, 8, 7\} = \{5\} \text{ and}$$

$$\begin{aligned} A + B &= \{2, 5, 6, 3\} + \{5, 0, 1, 8, 7\} \\ &= \{2, 5, 6, 3, 7, 8, 1, 0, 4, 9\} \end{aligned}$$

are in  $T_{\cap}^+$  and  $T_{\cap}^+$  is different from  $T_{\cup}^+$ ,  $T_{\cup}^{\times}$  and  $T_0$  as subset ring semiring topological spaces.

Let  $A, B \in T_{\cap}^{\times}$ ;

$$A \cap B = \{5\} \text{ and}$$

$$\begin{aligned} A \times B &= \{2, 5, 6, 3\} \times \{5, 0, 1, 8, 7\} \\ &= \{0, 2, 5, 6, 3, 8, 4, 1\} \in T_{\cap}^{\times}. \end{aligned}$$

We see  $T_{\cap}^{\times}$  is distinctly different from  $T_{\cap}^+$ ,  $T_{\cup}^+$ ,  $T_{\cup}^{\times}$  and  $T_0$  as subset semiring ring topological spaces.

Consider  $A, B \in T_s$ ,

$$\begin{aligned} A + B &= \{2, 5, 6, 3\} + \{5, 0, 1, 8, 7\} \\ &= \{2, 5, 6, 3, 7, 1, 8, 4, 9, 0\} \text{ and} \end{aligned}$$

$$\begin{aligned} A \times B &= \{2, 5, 6, 3\} \times \{5, 0, 1, 8, 7\} \\ &= \{0, 2, 5, 6, 3, 4, 8, 1\} \text{ are in } T_s. \end{aligned}$$

Thus  $T_s$  is different from  $T_{\cup}^+$ ,  $T_{\cup}^{\times}$ ,  $T_{\cap}^+$ ,  $T_{\cap}^{\times}$  and  $T_0$  as subset ring semiring topological spaces.

**Example 3.21:** Let

$S = \{\text{Collection of all subsets from the ring } C(Z_{17})\}$  be the subset semiring of type I. We have six different subset ring semiring topological spaces  $T_0$ ,  $T_{\cup}^+$ ,  $T_{\cup}^{\times}$ ,  $T_{\cap}^+$ ,  $T_{\cap}^{\times}$  and  $T_s$ .

All of them are of finite order.

**Example 3.22:** Let

$S = \{\text{Collection of all subsets from the ring } Z_5S_4\}$  be the subset semiring of type I. We have  $T_o, T_{\cup}^+, T_{\cup}^{\times}, T_{\cap}^+, T_{\cap}^{\times}$  and  $T_S$  are the six subset ring semiring topological spaces of  $S$ . We see  $T_{\cup}^+, T_{\cap}^{\times}$  and  $T_S$  are the three subset ring semiring topological spaces which are non commutative.

**Example 3.23:** Let

$S = \{\text{Collection of all subsets from the ring } (Z_4 \times Z_7) A_4\}$  be the subset semiring of type I.  $T_o, T_{\cup}^+, T_{\cup}^{\times}, T_{\cap}^+, T_{\cap}^{\times}$  and  $T_S$  are the six different subset ring semiring topological spaces of  $S$ .  $T_{\cup}^+, T_{\cap}^{\times}$  and  $T_S$  are the three non commutative subset ring semiring topological spaces of finite order.

**Example 3.24:** Let  $S = \{\text{Collection of all subsets from the polynomial ring}$

$$M = \left\{ \sum_{i=0}^{\infty} a_i x^i \mid a_i \in \mathbb{R} \right\}$$

be the subset semiring of type I.

Let  $A = \{5x^3 + 6x + 1, 3x^2 + 1, 15x^4 + 4\}$  and  $B = \{9x^7 + 1, 8x^5\} \in S$  if  $A, B \in T_o$ .

$$\begin{aligned} A \cup B &= \{5x^3 + 6x + 1, 3x^2 + 1, 15x^4 + 4\} \cup \{9x^7 + 1, 8x^5\} \\ &= \{5x^3 + 6x + 1, 3x^2 + 1, 15x^4 + 4, 8x^5, 9x^7 + 1\} \end{aligned}$$

and

$$\begin{aligned} A \cap B &= \{5x^3 + 6x + 1, 3x^2 + 1, 15x^4 + 4\} \cap \{9x^7 + 1, 8x^5\} \\ &= \phi \text{ are in } T_o. \end{aligned}$$

So  $T_o$  is a subset ring semiring topological space.

Let  $A, B \in T_{\cup}^+$ ;

$$\begin{aligned} A + B &= \{5x^3 + 6x + 1, 3x^2 + 1, 15x^4 + 4\} + \{9x^7 + 1, 8x^5\} \\ &= \{9x^7 + 2 + 5x^3 + 6x, 9x^7 + 3x^2 + 2, 9x^7 + 15x^4 + 5, \\ &\quad 8x^5 + 5x^3 + 6x + 1, 8x^5 + 3x^2 + 1, 8x^5 + 15x^4 + 4\} \end{aligned}$$

and

$$\begin{aligned} A \cup B &= \{5x^3 + 6x + 1, 3x^2 + 1, 15x^4 + 4\} \cup \{9x^7 + 1, 8x^5\} \\ &= \{5x^3 + 6x + 1, 3x^2 + 1, 5x^4 + 4, 9x^7 + 1, 8x^5\} \text{ are} \\ &\quad \text{in } T_{\cup}^+; \end{aligned}$$

$T_{\circ}$  is different from  $T_{\cup}^+$  as subset semiring topological space.

$$\begin{aligned} A + B &= \{5x^3 + 6x + 1, 3x^2 + 1, 15x^4 + 4\} + \{9x^7 + 1, 8x^5\} \\ &= \{9x^7 + 5x^3 + 6x + 2, 3x^2 + 9x^7 + 2, 9x^7 + 15x^4 + 5, \\ &\quad 8x^5 + 15x^4 + 4\} \end{aligned}$$

and

$$\begin{aligned} A \cap B &= \{5x^3 + 6x + 1, 3x^2 + 1, 15x^4 + 4\} \cap \{9x^7 + 1, 8x^5\} \\ &= \phi \text{ are in } T_{\cup}^+ \text{ and } T_{\cap}^+ \text{ are different as subset ring} \end{aligned}$$

semiring topological spaces.

Let  $A, B \in T_{\cup}^{\times}$

$$\begin{aligned} A \times B &= \{5x^3 + 6x + 1, 3x^2 + 1, 15x^4 + 4\} \times \{9x^7 + 1, 8x^5\} \\ &= 40x^8 + 48x^6 + 8x^5, 24x^7 + 8x^5 + 120x^9 + 32x^5, \\ &\quad (3x^2 + 1)(9x^7 + 1)(5x^3 + 6x + 1)(9x^7 + 1), (15x^4 \\ &\quad + 4)(9x^7 + 1)\} \text{ and} \end{aligned}$$

$$\begin{aligned} A \cup B &= \{5x^3 + 6x + 1, 3x^2 + 1, 15x^4 + 4\} \cup \{9x^7 + 1, 8x^5\} \\ &= \{5x^3 + 6x + 1, 8x^5, 3x^2 + 1, 15x^4 + 4, 9x^7 + 1\} \\ &\quad \text{and in } T_{\cup}^{\times}. \end{aligned}$$

$T_{\cup}^{\times}$  is different from  $T_{\circ}$ ,  $T_{\cup}^{+}$  and  $T_{\cap}^{+}$  as subset ring semiring topological spaces.

Let  $A, B \in T_{\cap}^{\times}$ .

$$\begin{aligned} A \times B &= \{5x^3 + 6x + 1, 3x^2 + 1, 15x^4 + 4\} \times \{9x^7 + 1, 8x^5\} \\ &= \{40x^8 + 48x^6 + 8x^5, 24x^7 + 8x^5, 32x^5 + 120x^9, \\ &\quad 45x^{10} + 54x^8 + 9x^7 + 5x^3 + 6x + 1, 27x^9 + 3x^2 + \\ &\quad 9x^7 + 1, 4 + 15x^4 + 36x^7 + 135x^{11}\} \text{ and} \end{aligned}$$

$$\begin{aligned} A \cap B &= \{5x^3 + 6x + 1, 3x^2 + 1, 15x^4 + 4\} \cap \{9x^7 + 1, 8x^5\} \\ &= \{\emptyset\} \text{ are in } T_{\cap}^{\times}. \end{aligned}$$

$T_{\cap}^{\times}$  is different from the subset ring semiring topological spaces  $T_{\cup}^{+}$ ,  $T_{\cup}^{\times}$ ,  $T_{\cap}^{+}$  and  $T_{\circ}$ .

Similar  $T_s = \{S, +, \times\}$  is also a subset ring semiring topological space of  $S$ . All the six topological spaces are distinct and of finite order. Further all the six spaces are commutative.

**Example 3.25:** Let  $S = \{\text{Collection of all subsets from the ring}$

$$R = \left\{ \left[ \begin{array}{c} \overline{a_1} \\ \overline{a_2} \\ \overline{a_3} \\ \overline{a_4} \\ \overline{a_5} \\ \overline{a_6} \\ \overline{a_7} \\ \overline{a_8} \end{array} \right] \mid a_i \in \mathbb{Z}; 1 \leq i \leq 8 \right\}$$

be the subset ring semiring.

$T_o$ ,  $T_{\cup}^+$ ,  $T_{\cup}^{\times}$ ,  $T_{\cap}^+$ ,  $T_{\cap}^{\times}$  and  $T_s$  are the six subset ring semiring topological spaces of S.

We have subset zero divisors and subset ring semiring topological subspaces  $M_1$  and  $M_2$  such

$$M_1 \times M_2 = \left\{ \begin{bmatrix} 0 \\ \overline{0} \\ 0 \\ \overline{0} \\ 0 \\ 0 \\ 0 \\ \overline{0} \end{bmatrix} \right\}.$$

We have many such subspaces of  $T_{\cup}^{\times}$  (or  $T_{\cap}^{\times}$  or  $T_s$ ).

Consider  $M_1 = \{\text{Collection of all subsets from the subring super matrix}$

$$A = \left\{ \begin{bmatrix} 0 \\ \overline{a_1} \\ a_2 \\ \overline{0} \\ 0 \\ 0 \\ 0 \\ \overline{a_3} \end{bmatrix} \mid a_1, a_2, a_3 \in Z \right\}$$



and  $M_2 = \{\text{Collection of all subsets from the subring super matrix}\}$

$$B = \left\{ \left[ \begin{array}{c} \overline{a_1} \\ \overline{0} \\ \overline{0} \\ \overline{0} \\ a_2 \\ a_3 \\ \overline{0} \\ \overline{0} \end{array} \right] \mid a_i \in \mathbb{Z}; 1 \leq i \leq 3 \right\}$$

be the subset ring semiring topological subspaces of  $T_s$  (or  $T_U^\times$  or  $T_\cap^\times$ ).

$$\text{We see } M_1 \times M_2 = \left\{ \left[ \begin{array}{c} \overline{0} \\ \overline{0} \\ \overline{0} \\ \overline{0} \\ \overline{0} \\ \overline{0} \\ \overline{0} \\ \overline{0} \end{array} \right] \right\}.$$

Let  $N_1 = \{\text{Collection of all subsets from the super matrix subring}\}$

$$C = \left\{ \left[ \begin{array}{c} \overline{0} \\ \overline{0} \\ \overline{0} \\ a_1 \\ a_2 \\ a_3 \\ a_4 \\ \overline{0} \end{array} \right] \mid a_i \in \mathbb{Z}; 1 \leq i \leq 4 \right\} \text{ and}$$

$N_2 = \{\text{Collection of all subsets from the super matrix subring}$

$$D = \left\{ \left[ \begin{array}{c} \overline{0} \\ a_1 \\ \overline{0} \\ \overline{0} \\ 0 \\ 0 \\ 0 \\ \overline{0} \\ a_2 \end{array} \right] \mid a_1 a_2 \in \mathbb{Z} \right\}$$

be the subset ring subsemiring topological subspaces of  $T_s$  (or  $T_{\cup}^{\times}$  or  $T_{\cap}^{\times}$ ) are such that

$$N_1 \times N_2 = \left\{ \left[ \begin{array}{c} \overline{0} \\ \overline{0} \\ \overline{0} \\ \overline{0} \\ 0 \\ 0 \\ 0 \\ \overline{0} \\ \overline{0} \end{array} \right] \right\}.$$

**Example 3.26:** Let  $S = \{\text{Collection of all subsets from the super matrix ring}\}$

$$M = \left\{ \left[ \begin{array}{ccc|ccc} a_1 & a_2 & a_3 & a_4 & a_5 & a_6 \\ a_7 & a_8 & a_9 & a_{10} & a_{11} & a_{12} \end{array} \right] \mid a_i \in C(Z_8); 1 \leq i \leq 12 \right\}$$

be the subset ring semiring super matrix of type I.

We see all the subset ring semiring topological spaces  $T_o$ ,  $T_{\cup}^+$ ,  $T_{\cup}^{\times}$ ,  $T_{\cap}^+$ ,  $T_{\cap}^{\times}$  and  $T_s$  are distinct.

$S$  has subset ring semiring topological subspaces  $M_i$  in  $T_{\cup}^{\times}$

$$(T_{\cap}^{\times} \text{ and } T_s) \text{ are such that } M_i \times M_j = \left\{ \left[ \begin{array}{ccc|ccc} 0 & 0 & 0 & 0 & 0 & 0 \\ 0 & 0 & 0 & 0 & 0 & 0 \end{array} \right] \right\}$$

if  $i \neq j$ .

**Example 3.27:** Let  $S = \{\text{Collection of all subsets from the ring}\}$

$$M = \left\{ \left[ \begin{array}{cc|cc|c} a_1 & a_2 & a_3 & a_4 & a_5 \\ a_6 & a_7 & a_8 & a_9 & a_{10} \\ a_{11} & a_{12} & a_{13} & a_{14} & a_{15} \\ a_{16} & a_{17} & a_{18} & a_{19} & a_{20} \end{array} \right] \mid a_i \in C(\langle Z_{12} \cup I \rangle); 1 \leq i \leq 20 \right\}$$

be the subset ring semiring of type I.  $S$  has subset ring semiring topological spaces  $T_o$ ,  $T_{\cup}^+$ ,  $T_{\cup}^{\times}$ ,  $T_{\cap}^+$ ,  $T_{\cap}^{\times}$  and  $T_s$ .

$S$  has subset ring semiring topological subspaces  $M_i$  in  $T_s$  ( $T_{\cup}^{\times}$  and  $T_{\cap}^{\times}$ ) ( $i$  varies) such that

$$M_i \cap M_j = \left\{ \begin{array}{c|c|c|c|c} 0 & 0 & 0 & 0 & 0 \\ \hline 0 & 0 & 0 & 0 & 0 \\ 0 & 0 & 0 & 0 & 0 \\ \hline 0 & 0 & 0 & 0 & 0 \end{array} \right\} \text{ if } i \neq j.$$

That is  $T_o$  ( $T_{\cup}^+$ ,  $T_{\cup}^{\times}$ ,  $T_{\cap}^+$ ,  $T_{\cap}^{\times}$  and  $T_s$ ) has subset ring semiring orthogonal topological subspaces.

**Example 3.28:** Let  $S = \{\text{Collection of all subsets from the interval matrix ring } \{([a_1, b_1], [a_2, b_2], [a_3, b_3], [a_4, b_4]) \mid a_i, b_i \in C(Z_{25}); 1 \leq i \leq 4\}\}$  be the interval subset ring semiring of type I.

$S$  has several subset zero divisors and  $S$  has subset interval ring subsemirings say  $M_1, M_2$  such that

$M_1 \times M_2 = \{([0, 0], [0, 0], [0, 0], [0, 0])\}$ .  $S$  has subset interval ring semiring topological spaces of type I.

**Example 3.29:** Let  $S = \{\text{Collection of all intervals } [a, b] \text{ where } a, b \in Z\}$  be the subset ring interval semiring.  $T_o, T_{\cup}^+, T_{\cup}^{\times}, T_{\cap}^+, T_{\cap}^{\times}$  and  $T_s$  are the 6 subset topological semiring space of type I.

**Example 3.30:** Let  $S = \{\text{Collection of all subsets from the interval matrix ring}$

$$M = \left\{ \left[ \begin{array}{c} [a_1, b_1] \\ [a_2, b_2] \\ \vdots \\ [a_{10}, b_{10}] \end{array} \right] \mid a_i, b_i \in \langle Z \cup I \rangle; 1 \leq i \leq 10 \right\}$$

be the subset interval ring semiring of type I.

$P_1 = \{\text{Collection of all subsets from the subring}$

$$\left\{ \begin{matrix} [a_1, 0] \\ [a_2, 0] \\ \vdots \\ [a_{10}, 0] \end{matrix} \right\} \left| a_i \in \langle Z \cup I \rangle ; 1 \leq i \leq 10 \right\} \subseteq S$$

be the subset semiring topological subspaces of  $T_o$ ,  $T_\cup^+$ ,  $T_\cup^\times$ ,  $T_\cap^+$ ,  $T_\cap^\times$  and  $T_s$ .

Associated with  $S$  we have the subset interval semiring topological spaces  $T_o$ ,  $T_\cup^+$ ,  $T_\cup^\times$ ,  $T_\cap^+$ ,  $T_\cap^\times$  and  $T_s$ .

**Example 3.31:** Let  $S = \{ \text{Collection of all subsets from the interval ring } \{([a_1, b_1], [a_2, b_2] | [a_3, b_3] | [a_4, b_4], [a_5, b_5] | [a_6, b_6]) | a_i, b_i \in C(Z_{10}); 1 \leq i \leq 6\} \}$  be the subset ring semiring.

$T_o$ ,  $T_\cup^+$ ,  $T_\cup^\times$ ,  $T_\cap^+$ ,  $T_\cap^\times$  and  $T_s$  are the subset ring semiring topological spaces of  $S$ . All the six are distinct as topological spaces.

All the six subset semiring topological spaces has subset semiring topological subspaces.

**Example 3.32:** Let  $S = \{ \text{Collection of all subsets from the matrix ring}$

$$M = \left\{ \begin{matrix} [a_1, b_1] & [a_2, b_2] & \dots & [a_{10}, b_{10}] \\ [a_{11}, b_{11}] & [a_{12}, b_{12}] & \dots & [a_{20}, b_{20}] \\ [a_{21}, b_{21}] & [a_{22}, b_{22}] & \dots & [a_{30}, b_{30}] \\ [a_{31}, b_{31}] & [a_{32}, b_{32}] & \dots & [a_{40}, b_{40}] \end{matrix} \right\} \left| a_i, b_i \in Z_{12}(g_1, g_2, g_3); \right.$$

$$1 \leq i \leq 40; g_1^2 = 0, g_2^2 = g_2, g_3^2 = -g_3, g_i g_j = g_j g_i = 0, 1 \leq i, j \leq 3, i \neq j \}$$

be the subset ring semiring of infinite order.

$T_o, T_{\cup}^+, T_{\cup}^{\times}, T_{\cap}^+, T_{\cap}^{\times}$  and  $T_s$  are the subset semiring topological spaces of S.

**Example 3.33:** Let  $S = \{\text{Collection of all subsets of the ring}$

$$M = \left\{ \left[ \begin{array}{c} [a_1, b_1] \\ [a_2, b_2] \\ [a_3, b_3] \\ [a_4, b_4] \\ [a_5, b_5] \\ [a_6, b_6] \\ [a_7, b_7] \end{array} \right] \mid a_i, b_i \in C\langle Z_{16} \cup I \rangle ; 1 \leq i \leq 7 \right\}$$

be the subset ring semiring of type I.

$T_o, T_{\cup}^+, T_{\cup}^{\times}, T_{\cap}^+, T_{\cap}^{\times}$  and  $T_s$  are subset ring semiring topological space of type I.

**Example 3.34:** Let  $S = \{\text{Collection of all subsets from the interval matrix ring}$

$$M = \left\{ \left[ \begin{array}{cc|cc|cc|cc} [a_1, b_1] & [a_2, b_2] & [a_3, b_3] & [a_4, b_4] & [a_5, b_5] & [a_6, b_6] & [a_7, b_7] & [a_8, b_8] \\ [a_9, b_9] & [a_{10}, b_{10}] & [a_{11}, b_{11}] & [a_{12}, b_{12}] & [a_{13}, b_{13}] & [a_{14}, b_{14}] & [a_{15}, b_{15}] & [a_{16}, b_{16}] \\ [a_{17}, b_{17}] & [a_{18}, b_{18}] & [a_{19}, b_{19}] & [a_{20}, b_{20}] & [a_{21}, b_{21}] & [a_{22}, b_{22}] & [a_{23}, b_{23}] & [a_{24}, b_{24}] \\ [a_{25}, b_{25}] & [a_{26}, b_{26}] & [a_{27}, b_{27}] & [a_{28}, b_{28}] & [a_{29}, b_{29}] & [a_{30}, b_{30}] & [a_{31}, b_{31}] & [a_{32}, b_{32}] \end{array} \right] \mid a_i, b_i \in C\langle Z_7 \cup I \rangle S_7 ; 1 \leq i \leq 30 \right\}$$

be the subset ring semiring which is non commutative.

$T_0, T_{\cup}^+, T_{\cup}^{\times}, T_{\cap}^+, T_{\cap}^{\times}$  and  $T_S$  are subset ring semiring topological spaces of  $S$ .

$T_{\cup}^{\times}, T_{\cap}^{\times}$  and  $T_S$  are subset ring semiring topological space which is non commutative and of finite order.

Clearly  $T_0, T_{\cup}^+, T_{\cup}^{\times}, T_{\cap}^+, T_{\cap}^{\times}$  and  $T_S$  has subset ring semiring topological subspaces.

**Example 3.35:** Let  $S = \{\text{Collection of all subsets from the ring}$

$$M = \left\{ \sum_{i=0}^{\infty} [a_i, b_i] x^i \mid a_i, b_i \in \mathbb{R} \right\}$$

be the subset ring interval semiring of infinite order.

$T_0, T_{\cup}^+, T_{\cup}^{\times}, T_{\cap}^+, T_{\cap}^{\times}$  and  $T_S$  be the subset ring interval semiring topological spaces.

All the six subset semiring topological spaces has subspaces.

**Example 3.36:** Let  $S = \{\text{Collection of all subsets from the ring}$

$$M = \left\{ \left[ \begin{array}{ccc} [a_1, b_1] & [a_2, b_2] & [a_3, b_3] \\ [a_4, b_4] & [a_5, b_5] & [a_6, b_6] \\ [a_7, b_7] & [a_8, b_8] & [a_9, b_9] \end{array} \right] \mid a_i, b_i \in \mathbb{Z}_{36}; 1 \leq i \leq 9 \right\}$$

be the subset ring semiring of finite order.

$T_0, T_{\cup}^+, T_{\cup}^{\times}, T_{\cap}^+, T_{\cap}^{\times}$  and  $T_S$  be the subset ring semiring topological spaces of  $S$ . We see all the six spaces has subspaces

$$M_i \cap M_j = \left\{ \begin{bmatrix} [0,0] & [0,0] & [0,0] \\ [0,0] & [0,0] & [0,0] \\ [0,0] & [0,0] & [0,0] \end{bmatrix} \right\}, i \neq j.$$

For instance take

$$M_1 = \left\{ \begin{bmatrix} [a_1, b_1] & [0,0] & [0,0] \\ [0,0] & [0,0] & [a_2, b_2] \\ [0,0] & [a_3, b_3] & [0,0] \end{bmatrix} \mid a_i, b_i \in \mathbb{Z}_{36}; 1 \leq i \leq 3 \right\}$$

and  $P_1 = \{\text{Collection of all subsets from the subring } M_1\}$  be the subset subring subsemiring of  $S$ .

$$M_2 = \left\{ \begin{bmatrix} [0,0] & [a_1, b_1] & [0,0] \\ [a_2, b_2] & [0,0] & [0,0] \\ [0,0] & [0,0] & [a_3, b_3] \end{bmatrix} \mid a_i, b_i \in \mathbb{Z}_{36}; 1 \leq i \leq 3 \right\}$$

and  $P_2 = \{\text{Collection of all subsets from the subring } M_2\}$  be the subset subring subsemiring of  $S$ .

$M_1$  and  $M_2$  are subset ring semiring topological subspaces of  $T_o, T_U^+, T_U^\times, T_\cap^+, T_\cap^\times$  and  $T_S$  such that

$$M_1 \cap M_2 = \left\{ \begin{bmatrix} [0,0] & [0,0] & [0,0] \\ [0,0] & [0,0] & [0,0] \\ [0,0] & [0,0] & [0,0] \end{bmatrix} \right\};$$

hence  $M_1$  and  $M_2$  are orthogonal subset semiring topological subspaces of  $T_o, T_U^+, T_U^\times, T_\cap^+, T_\cap^\times$  and  $T_S$ .

We have seen examples of subset ring topological spaces.



Now we proceed onto describe other types of subset topological semiring spaces of type I.

Let S be the subset ring semiring.

Suppose  $B = \{\text{Collection of all subset subsemiring of } S\}$ ; then B can be given all the six topological structures  $B_o, B_{\cup}^+, B_{\cup}^{\times}, B_{\cap}^+, B_{\cap}^{\times}$  and  $B_s$ .  $B_o = \{\text{Collection of all subset subsemirings of } S\} = \{B \cup \{\phi\}, \cup, \cap\}$  is the usual or ordinary subset subsemiring of S.

$B_{\cup}^+ = \{B, +, \cup\}$  be the subset semiring topological subset subspace.  $B_{\cap}^+ = \{B', +, \cap\}$  be the subset semiring subset subspace.  $B_{\cup}^{\times} = \{B, \cup, \times\}$  is again a subset semiring topological subspace and  $B_{\cap}^{\times} = \{B', +, \cup\}$  is again a subset semiring topological subspace of  $T_{\cup}^{\times}$ .

$B_{\cap}^{\times} = \{B', \times, \cap\}$  is again a subset ring semiring topological subspace of  $T_{\cap}^{\times}$ .

Finally  $B_s = \{B, +, \times\}$  is again a subset ring semiring topological subspace of  $T_s$ .

**Example 3.37:** Let S = {Collection of all subsets from the super matrix interval ring

$$M = \left\{ \left[ \begin{array}{c} [a_1, b_1] \\ [a_2, b_2] \\ [a_3, b_3] \\ [a_4, b_4] \\ [a_5, b_5] \\ [a_6, b_6] \end{array} \right] \mid a_i, b_i \in Z_{12}; 1 \leq i \leq 6 \right\}$$

be the subset interval super matrix semiring.

S has subset interval matrix subsemirings, subset interval idempotents, subset interval zero divisors and subset interval semiring ideals.

Clearly S is under the natural product  $\times_n$  of super matrices.

**Example 3.38:** Let  $S = \{\text{Collection of all subsets from the interval ring } \{([a_1, b_1] \mid [a_2, b_2] \mid [a_3, b_3] \mid [a_4, b_4]) \mid a_i, b_i \in \mathbb{Z}_4; 1 \leq i \leq 4\}\}$  be the subset super interval ring matrix semiring.

S has subset interval idempotents, subset interval zero divisors and has subset interval units.

S has subset interval subsemirings and subset interval semiring ideals. S is of finite order.

All the topological space  $T_o$ ,  $T_\cap^\times$  and  $T_\cup^\times$  exist.

**Example 3.39:** Let

$S = \{\text{Collection of all subsets from the ring } C(\mathbb{Z}_{18})\}$  be the subset semiring.

S is of finite order, S has subset subsemirings and subset units.

**Example 3.40:** Let  $S = \{\text{Collection of all subsets from the ring}$

$$M = \left\{ \left[ \begin{array}{c} [a_1, b_1] \\ [a_2, b_2] \\ [a_3, b_3] \\ [a_4, b_4] \\ [a_5, b_5] \\ [a_6, b_6] \end{array} \right] \mid a_i, b_i \in C(\mathbb{Z}_7); 1 \leq i \leq 6 \right\}$$

be the subset super matrix interval semiring. S has finite number of subset interval zero divisors, subset interval units and subset interval idempotents.

**Example 3.41:** Let  $S = \{\text{Collection of all subsets from the ring } C(Z_5) \times C(Z_{11}) \times C(Z_{17})\}$  be the subset complex modulo integer semiring of finite order.  $S$  has subset zero divisors, subset units, subset idempotents.

**Example 3.42:** Let  $S = \{\text{Collection of all subsets from the ring}$

$$M = \left\{ \left[ \begin{array}{c|c|c|c} a_1 & a_2 & a_3 & a_4 \\ \hline a_5 & a_6 & a_7 & a_8 \\ \hline a_9 & a_{10} & a_{11} & a_{12} \\ \hline a_{13} & a_{14} & a_{15} & a_{16} \end{array} \right] \mid a_i \in P = \{\text{The interval ring of } C(Z_{18}); a_i = [x_i, y_i] \ x_i, y_i \in C(Z_{18}); 1 \leq i \leq 16\} \right\}$$

be the subset super matrix semiring of finite order.  $S$  has subset interval idempotents and subset interval zero divisors.

**Example 3.43:** Let  $S = \{\text{Collection of all subsets from the matrix ring}$

$$M = \left\{ \left[ \begin{array}{cccc} [a_1, b_1] & [a_2, b_2] & [a_3, b_3] & [a_4, b_4] \\ [a_5, b_5] & [a_6, b_6] & [a_6, b_6] & [a_8, b_8] \\ \vdots & \vdots & \vdots & \vdots \\ [a_{41}, b_{41}] & [a_{42}, b_{42}] & [a_{43}, b_{43}] & [a_{44}, b_{44}] \end{array} \right] \right\}$$

be the intervals from  $C(Z_{42})\}$  be the subset interval matrix semiring under natural product  $\times_n$  of matrices.

The six topological spaces  $T_o, T_{\cup}^+, T_{\cup}^{\times}, T_{\cap}^+, T_{\cap}^{\times}$  and  $T_s$  are distinct and all of them are only commutative topological spaces. All the six spaces have finite number of subspaces. Further  $S$  has subset zero divisors and subset interval idempotents.

Now we proceed onto describe the new notion of subset semiring topological spaces using subset semiring of type II.

Just for the sake of completeness we recall a few examples of subset semiring of type II.

**Example 3.44:** Let  $S = \{\text{Collection of all subsets from the semiring } L =$

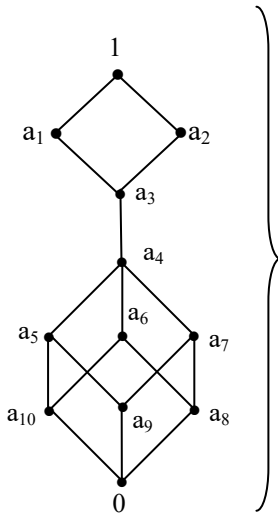

be the subset semiring of type II.

Clearly  $S$  is of finite order but a commutative subset semiring of type II.

In fact this  $S$  has several zero divisors and subset subsemirings.

**Example 3.45:** Let  $S = \{\text{Collection of all subsets from the semiring } (Z^+ \cup \{0\}) (g_1, g_2) \text{ where } g_1^2 = 0, g_2^2 = g_2, g_1g_2 = g_2g_1 = 0\}$  be the subset semiring of type II.

$S$  is of infinite order and  $S$  is commutative and has subset zero divisors.

Also  $S$  has infinite number of subset subsemirings of infinite order.

**Example 3.46:** Let  $S = \{\text{Collection of all subsets from the semiring } C(\langle \mathbb{Z}_{20} \cup I \rangle)\}$  be the subset semiring.  $S$  is of finite order known as the complex neutrosophic modulo integer subset semiring.

**Example 3.47:** Let  $S = \{\text{Collection of all subsets from the semiring; } L =$

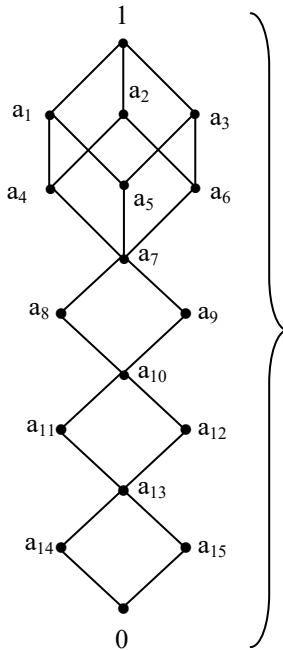

be the subset semiring of finite order which is commutative and has subset zero divisors as well as subset idempotents.

It is pertinent to keep on record that every  $A_i = \{a_i\}; 1 \leq i \leq 15$  are all such that  $A_i \cap A_i = A_i = \{a_i\}$  and  $A_i \cup A_i = A_i; 1 \leq i \leq 15$ .

**Example 3.48:** Let  $S = \{\text{Collection of all subsets form the semiring } (\mathbb{Z}^+ \cup \{0\}) (S_7 \times D_{2,5})\}$  be the subset semiring.  $S$  is of infinite order but non commutative.

S has infinite number of both commutative and non commutative subset subsemirings. For instance take  $P = \{(\mathbb{Z}^+ \cup \{0\}) (P_1 \times \{1\})\}$  where

$P_1 = \left\langle \left( \begin{matrix} 1 & 2 & 3 & 4 & 5 & 6 & 7 \\ 2 & 3 & 4 & 5 & 6 & 7 & 1 \end{matrix} \right) \right\rangle$  is a cyclic group of order seven.

Hence P is a commutative subset subsemiring of infinite order.

**Example 3.49:** Let  $S = \{\text{Collection of all subsets from the semiring which is a lattice group } LS_4 \text{ with } L =$

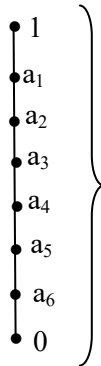

be the subset semiring of type II of finite order.

S is non commutative S has no subset zero divisors but has subset idempotents.

**Example 3.50:** Let  $S = \{\text{Collection of all subsets from the semigroup lattice } LS(5) \text{ where } S(5) \text{ is the symmetric semigroup and } L \text{ is the following lattice;}$

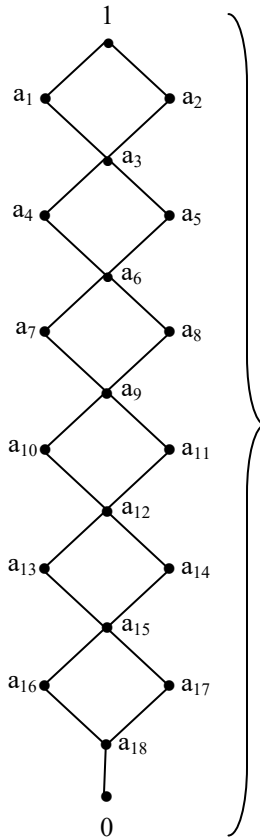

be the subset semiring of type II.

S is of finite order but is non commutative. S has finite number of subset idempotents but has no subset zero divisors.

S has finite number of subset subsemirings and also S has some subsemirings which are commutative.

**Example 3.51:** Let  $S = \{\text{Collection of all subsets from the lattice } L_1 \times L_2 = L \text{ where}$

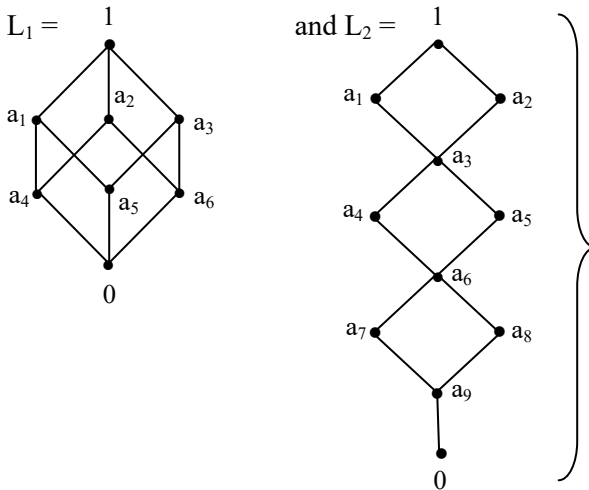

be the subset semiring of finite order.

$S$  has only finite number of subset idempotents and a few subset zero divisors.

We can using the semirings give examples of subset matrix semirings.

**Example 3.52:** Let  $S = \{\text{Collection of all subsets from the matrix semiring}\}$

$$M = \left\{ \left[ \begin{array}{cccc} a_1 & a_2 & \dots & a_{10} \\ a_{11} & a_{12} & \dots & a_{20} \\ a_{21} & a_{22} & \dots & a_{30} \end{array} \right] \mid a_i \in \mathbb{Z}^+ \cup \{0\}; 1 \leq i \leq 30 \right\}$$

be the subset semiring of infinite order. Clearly  $S$  has infinite number of subset zero divisors as well as infinite number of subset subsemirings. However the operation is natural product  $\times_n$  on matrices.



**Example 3.53:** Let  $S = \{\text{Collection of all subsets from the}$

$$\text{semiring } M = \left\{ \left[ \begin{array}{c} d_1 \\ d_2 \\ d_3 \\ \vdots \\ d_5 \end{array} \right] \mid d_i \in \right.$$

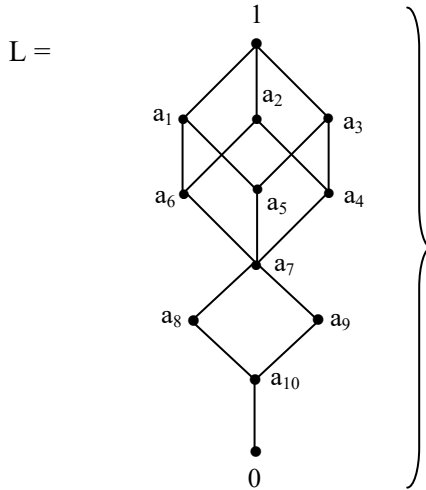

be the subset semiring of finite order.

This  $S$  has both subset idempotents and subset zero divisors. For every  $a_i \in L$  is such that  $a_i \times a_i = a_i$ ,  $1 \leq i \leq 90$ .

$$\text{Take } X_i = \left\{ \left[ \begin{array}{c} a_i \\ 0 \\ \vdots \\ 0 \end{array} \right] \right\} \in S; X_i \times_n X_i = \left\{ \left[ \begin{array}{c} a_i \\ 0 \\ \vdots \\ 0 \end{array} \right] \right\} = X_i.$$

Thus we have atleast  $15 + 15C_2 + 15C_3 + 15C_4 + \dots + 15C_{15}$  number of subset idempotents.

Now we will describe the subset zero divisors in S.

$$\text{Take } X = \left\{ \begin{bmatrix} a_1 \\ a_2 \\ 0 \\ \vdots \\ 0 \end{bmatrix} \right\} \text{ and } Y = \left\{ \begin{bmatrix} 0 \\ 0 \\ a_3 \\ a_4 \\ 0 \\ \vdots \\ 0 \end{bmatrix} \right\} \in S;$$

$$\text{we see } X \times_n Y = \left\{ \begin{bmatrix} 0 \\ 0 \\ \vdots \\ 0 \end{bmatrix} \right\}.$$

Thus we can have finite number of subset zero divisors.

**Example 3.54:** Let  $S = \{\text{Collection of all subsets from the super matrix semiring}\}$

$$M = \left\{ \begin{bmatrix} a_1 & a_2 \\ a_3 & a_4 \\ a_5 & a_6 \\ a_7 & a_8 \\ a_9 & a_{10} \\ a_{11} & a_{12} \\ a_{13} & a_{14} \end{bmatrix} \mid a_i, b_i \in \mathbb{Z}^+ \cup \{0\}; 1 \leq i \leq 4 \right\}$$

be the subset semiring of super matrices.

S has infinite number of subset zero divisors but only a finite number of subset idempotents.

$$\text{For take } X = \left\{ \begin{bmatrix} \overline{1 \ 1} \\ 0 \ 0 \\ 0 \ 0 \\ \overline{1 \ 1} \\ 1 \ 1 \\ 0 \ 0 \\ \overline{0 \ 0} \end{bmatrix} \right\} \in S \text{ is such that}$$

$$X \times_n X = \left\{ \begin{bmatrix} \overline{1 \ 1} \\ 0 \ 0 \\ 0 \ 0 \\ \overline{1 \ 1} \\ 1 \ 1 \\ 0 \ 0 \\ \overline{0 \ 0} \end{bmatrix} \right\} \times_n \left\{ \begin{bmatrix} \overline{1 \ 1} \\ 0 \ 0 \\ 0 \ 0 \\ \overline{1 \ 1} \\ 1 \ 1 \\ 0 \ 0 \\ \overline{0 \ 0} \end{bmatrix} \right\}$$

$$= \left\{ \begin{bmatrix} \overline{1 \ 1} \\ 0 \ 0 \\ 0 \ 0 \\ \overline{1 \ 1} \\ 1 \ 1 \\ 0 \ 0 \\ \overline{0 \ 0} \end{bmatrix} \right\} = X.$$

One of the interesting problem is finding the number of subset idempotent in this case as they are only finite in number.

**Example 3.55:** Let  $S = \{\text{Collection of all subsets from the super matrix semiring}\}$

$$M = \left[ \begin{array}{cc|cc|c} a_1 & a_2 & a_3 & a_4 & a_5 & a_6 \\ a_7 & a_8 & a_9 & a_{10} & a_{11} & a_{12} \\ a_{13} & a_{14} & a_{15} & a_{16} & a_{17} & a_{18} \\ a_{19} & a_{20} & a_{21} & a_{22} & a_{23} & a_{24} \\ a_{25} & a_{26} & a_{27} & a_{28} & a_{29} & a_{30} \end{array} \right] a_i \in L =$$

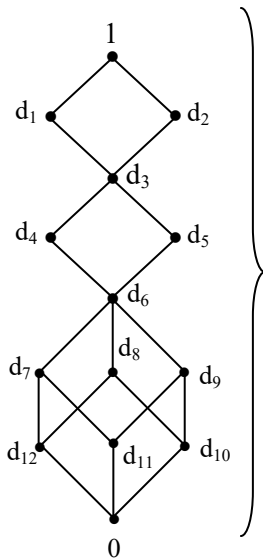

$1 \leq i \leq 30\}$  be the subset semiring of super matrices.

Clearly  $S$  has finite number of subset idempotents, subset zero divisors but has no subset units.

This is also an interesting problem to find the number of subset idempotents of  $S$ .

Now we can illustrate on similar lines the notion of neutrosophic subset semirings of infinite order but however we can get only finite complex modulo integer subset semirings as if we try to get complex subset semirings then it has to draw its entries only from the  $C$  which has infinite cardinality and its

basic structure is a field or a ring and not a semifield or a semiring.

Now we proceed onto describe the 6 new types of subset semiring topological spaces by some examples.

**Example 3.56:** Let  $S = \{\text{Collection of all subsets from the lattice } +, \times\}$

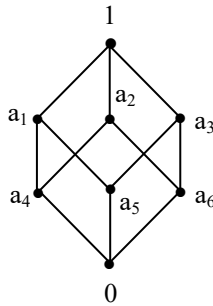

be the subset semiring of type II of finite order which is commutative (Here + is max and  $\times$  is min).

Let  $A = \{a_1, a_2, a_5\}$  and  
 $B = \{a_3, a_6, 0\} \in T_0 = \{S' = S \cup \{\phi\}, \cup, \cap\}$ .

We find  $A \cup B$  and  $A \cap B$

Consider

$$\begin{aligned} A \cup B &= \{a_1, a_2, a_5\} \cup \{a_3, a_6, 0\} \\ &= \{a_1, a_2, a_5, a_3, a_6, 0\} \end{aligned}$$

and

$$\begin{aligned} A \cap B &= \{a_1, a_2, a_5\} \cap \{a_3, a_6, 0\} \\ &= \{\phi\} \text{ are in } T_0. \end{aligned}$$

$T_0$  is the ordinary subset semiring topological space.

Let  $A, B \in T_0^+ = \{S, \cup, +\}$ ;

$$\begin{aligned} A \cup B &= \{a_1, a_2, a_5\} \cup \{a_3, a_6, 0\} \\ &= \{a_2, a_5, a_1, a_3, a_6, 0\} \end{aligned}$$

and  $A \cap B = \{a_1, a_2, a_5\} \cap \{a_3, a_6, 0\}$   
 $= \{a_1, a_2, a_5, 1, a_3\} \in T_{\cup}^+$ .

$T_0$  and  $T_{\cup}^+$  are different as topological spaces.

Let  $A, B \in T_{\cup}^+ = \{S, \cup, \times\}$

$$\begin{aligned} A \cup B &= \{a_1, a_2, a_5\} \cup \{a_3, a_6, 0\} \\ &= \{a_1, a_2, a_5, 0, a_3, a_6\} \end{aligned}$$

and

$$\begin{aligned} A \times B &= \{a_1, a_2, a_5\} \times \{a_3, a_6, 0\} \\ &= \{0, a_5, a_6\} \text{ are in } T_{\cup}^+ \text{ and } T_{\cup}^{\times} \text{ is different from } T_{\cup}^+ \end{aligned}$$

and  $T_0$ .

Now let  $A, B \in T_{\cap}^+ = \{S' = S \cup \{\phi\}, \cap, +\}$ ;

$$\begin{aligned} A + B &= \{a_1, a_2, a_5\} + \{0, a_3, a_6\} \\ &= \{a_1, a_2, a_5, 1, a_3, a_6\} \text{ and} \end{aligned}$$

$$\begin{aligned} A \cap B &= \{a_1, a_2, a_5\} \cap \{0, a_3, a_6\} \\ &= \phi \text{ are in } T_{\cap}^+ . \end{aligned}$$

$T_{\cap}^+$  is distinctly different from  $T_0$ ,  $T_{\cup}^+$  and  $T_{\cup}^{\times}$ .

Now take  $A, B \in T_{\cap}^{\times} = \{S' = S \cup \{\phi\}, \cap, \times\}$

$$\begin{aligned} A \cap B &= \{a_1, a_2, a_5\} \cap \{a_3, a_6, 0\} \\ &= \phi \text{ and} \end{aligned}$$

$$\begin{aligned} A \times B &= \{a_1, a_2, a_5\} \times \{a_3, a_6, 0\} \\ &= \{0, a_5, a_6\} \text{ are in } T_{\cap}^{\times} . \end{aligned}$$

Thus  $T_{\cap}^{\times}$  is a different subset semiring topological space from  $T_o$ ,  $T_{\cup}^+$ ,  $T_{\cup}^{\times}$  and  $T_{\cap}^+$ .

Finally let us consider  $A, B \in T_s = \{S, +, \times\}$  where  $+$  is max in  $L$  and  $\times$  is min on  $L$ .

$$\begin{aligned} A + B &= \{a_1, a_2, a_5\} + \{a_3, a_6, 0\} \\ &= \{a_1, a_2, a_5, 1, a_3, a_6\} \text{ and} \end{aligned}$$

$$\begin{aligned} A \times B &= \{a_1, a_2, a_5\} \times \{a_3, a_6, 0\} \\ &= \{0, a_5, a_6\} \text{ are in } T_s. \end{aligned}$$

$T_s$  the inherited subset semiring topological space of  $S$  and it is different from the other subset semiring topological spaces  $T_o$ ,  $T_{\cup}^+$ ,  $T_{\cup}^{\times}$ ,  $T_{\cap}^+$  and  $T_{\cap}^{\times}$ .

Thus in general we have for a given subset semiring six types of subset semiring topological spaces associated with it.

**Example 3.57:** Let  $S = \{\text{Collection of all subsets from the semiring } Q^+ \cup \{0\}\}$  be the subset semiring of type II. Let  $T_o$ ,  $T_{\cup}^+$ ,  $T_{\cup}^{\times}$ ,  $T_{\cap}^+$ ,  $T_{\cap}^{\times}$  and  $T_s$  be the six new types of subset semiring topological space associated with  $S$ .

$$\begin{aligned} \text{Let } A &= \{3, 7/5, 0, 4, 5, 10\} \\ \text{and } B &= \{4, 0, 8, 7, 5, 1\} \in T_o = \{S' = S \cup \{\phi\}, \cup, \cap\}; \end{aligned}$$

$$\begin{aligned} A \cap B &= \{3, 7/5, 0, 4, 5, 10\} \cap \{4, 0, 8, 7, 5, 1\} \\ &= \{0, 4, 5\} \text{ and} \end{aligned}$$

$$\begin{aligned} A \cup B &= \{3, 7/5, 0, 4, 5, 10\} \cup \{4, 0, 8, 7, 5, 1\} \\ &= \{3, 7/5, 0, 4, 5, 10, 8, 7, 1\} \end{aligned}$$

are in  $T_o$ , the ordinary subset semiring topological spaces.

$$\text{Let } A, B \in T_{\cup}^+ = \{S, \cup, +\};$$

$$A \cup B = \{3, 7/5, 0, 4, 5, 10\} \cup \{4, 0, 8, 7, 5, 1\}$$

$$= \{0, 3, 7/5, 4, 5, 10, 8, 7, 5, 1\} \text{ and}$$

$$A + B = \{3, 7/5, 0, 4, 5, 10\} + \{4, 0, 8, 7, 5, 1\}$$

$$= \{0, 1, 4, 5, 7, 8, 3, 7/5, 10, 4, 13/5, 6, 11, 8 + 7/5, 1, 12, 13, 18, 7 + 7/5, 17, 32 / 5, 9, 15\} \text{ are in } T_{\cup}^+$$

$T_{\cup}^+$  is different from  $T_0$  as topological subset semiring spaces.

$$\text{Let } A, B \in T_{\cup}^{\times} = \{S, \cup, \times\}$$

$$A \cup B = \{3, 7/5, 0, 4, 5, 10\} \cup \{4, 0, 8, 7, 5, 1\}$$

$$= \{3, 7/5, 0, 4, 5, 10, 8, 7, 1\}$$

$$\text{and } A \times B = \{3, 7/5, 0, 4, 5, 10\} \times \{4, 0, 8, 7, 5, 1\}$$

$$= \{0, 3, 7/5, 4, 5, 10, 12, 28/5, 16, 20, 40, 24, 56/5, 32, 40, 80, 21, 49/5, 28, 35, 70, 15, 7, 25, 50\}$$

are in  $T_{\cup}^{\times}$  and  $T_{\cup}^{\times}$  is different from  $T_0$  and  $T_{\cup}^+$  as subset semiring topological spaces.

$$\text{Let } A, B \in T_{\cap}^{\times}, \text{ now}$$

$$A \cap B = \{3, 7/5, 0, 4, 5, 10\} \cap \{4, 0, 8, 7, 5, 1\}$$

$$= \{0, 4, 5\} \text{ and}$$

$$A \times B = \{0, 12, 28/5, 16, 20, 40, 24, 56/5, 32, 80, 21, 49/5, 28, 35, 70, 15, 7, 25, 50, 3, 7/5, 0, 4, 5, 10\} \text{ are in } T_{\cap}^{\times}$$

$T_{\cap}^{\times}$  is a semiring subset topological space different from  $T_0$ ,  $T_{\cup}^+$ , and  $T_{\cup}^{\times}$ .

$$\text{Let } A, B \in T_{\cap}^+$$

$$A \cap B = \{3, 7/5, 0, 4, 5, 10\} \cap \{4, 0, 8, 7, 5, 1\}$$

$$= \{0, 4, 5\} \text{ and}$$



$$\begin{aligned} A + B &= \{3, 7/5, 0, 4, 5, 10\} + \{4, 0, 8, 7, 5, 1\} \\ &= \{3, 7/5, 10, 4, 5, 0, 8, 7, 1, 7, 27/5, 9, 14, 11, 47/5, \\ &\quad 12, 13, 18, 42/5, 17, 14, 18, 17, 15\} \text{ are in } T_{\cup}^+ \text{ and} \end{aligned}$$

$T_{\cup}^+$  is distinctly different from the topological subset  $T_{\circ}$ ,  $T_{\cup}^+$ ,  $T_{\cup}^{\times}$  and  $T_{\cap}^{\times}$ .

$$\text{Let } A, B \in T_s = \{S, +, \times\}$$

$$\begin{aligned} A + B &= \{3, 7/5, 0, 4, 5, 10\} + \{4, 0, 8, 7, 5, 1\} \\ &= \{3, 7/5, 0, 4, 5, 10, 7, 27/5, 9, 14, 18, 13, 12, 11, \\ &\quad 47/5, 42/5, 17, 8, 1, 32/5, 9, 15, 12/5, 6\} \end{aligned}$$

and

$$A \times B = \{3, 7/5, 0, 4, 5, 10\} \times \{4, 0, 8, 7, 5, 1\} \text{ are in } T_s.$$

$T_s$  is a subset semiring topological space different from  $T_{\circ}$ ,  $T_{\cup}^+$ ,  $T_{\cup}^{\times}$ ,  $T_{\cap}^+$  and  $T_{\cap}^{\times}$ .

We have seen examples of both finite and infinite subset semiring topological spaces both are commutative.

Now we proceed onto give examples of subset semiring topological spaces which are also non commutative. It is important to keep on record that  $T_{\circ}$ ,  $T_{\cup}^+$ ,  $T_{\cup}^{\times}$  are always commutative as subset semiring topological spaces if the basic semiring used is commutative or otherwise.

**Example 3.58:** Let  $S = \{\text{Collection of all subsets form the semiring } P = (Z^+ \cup \{0\})D_{2,8}\}$  be the subset semiring. Clearly the semiring  $P$  is non commutative so  $S$  is also non commutative.

$$\begin{aligned} \text{Let } A &= \{1, ab, b, a, ab^3, ab^5\} \\ \text{and } B &= \{a, b^2, b^3 ab^2\} \in T_{\circ} = \{S' = S \cup \{\emptyset\}, \cup, \cap\}; \end{aligned}$$

$$\begin{aligned} A \cup B &= \{1, ab, b, a, ab^3, ab^5\} \cup \{a, b^2, b^3, ab^2\} \\ &= \{1, ab, b, a, ab^3, ab^5, b^2, b^3, ab^2\} \end{aligned}$$

and

$$A \cap B = \{1, ab, b, a, ab^3, ab^5\} \cap \{a, b^2, b^3, ab^2\} = \{a\}$$

are in  $T_0$  the ordinary subset semiring topological space.

Let  $A, B \in T_0^+$

$$\begin{aligned} A + B &= \{1, ab, b, a, ab^3, ab^5\} + \{a, b^2, b^3, ab^2\} \\ &= \{1 + a, 1 + b^2, 1 + b^3, a + ab^5, b^2 + ab^5, 1 + ab^2, ab \\ &\quad + a, ab + b^2, b^3 + ab^5, ab + b^3, ab + ab^2, ab^2 + ab^5, \\ &\quad 2a + a + b^2 a + b^3 ab^5 + b^3 a + ab^2, a + ab^3, b^2 + \\ &\quad ab^3, b^3 + ab^3\} \end{aligned}$$

and

$$\begin{aligned} A \cup B &= \{1, ab, b, a, ab^3, ab^5\} \cup \{a, b^2, b^3, ab^2\} \\ &= \{1, ab, a, b, b^2, b^3, ab^3, ab^5, ab^5, ab^2\} \text{ are in } T_0^+. \end{aligned}$$

Clearly  $T_0$  and  $T_0^+$  are different as subset semiring topological spaces.

Let  $A, B \in T_0^\times$ ;

$$\begin{aligned} A \cup B &= \{1, ab, b, a, ab^3, ab^5\} \cup \{a, b^2, b^3, ab^2\} \\ &= \{1, ab, a, b, ab^3, ab^5, b^2, b^3, ab^2\} \text{ and} \end{aligned}$$

$$\begin{aligned} A \times B &= \{1, ab, b, a, ab^3, ab^5\} \times \{a, b^2, b^3, ab^2\} \\ &= \{a, aba, 1, ba, ab^3a, b^2, ab^3, ab^2, b^3, ab^5, ab^7, ab^3, \\ &\quad b^3, ab^4, b^4, ab^6, a, ab^2, abab^2, b^2, bab^2, ab^3ab^2, \\ &\quad ab^5ab^2\} \text{ are in } T_0^\times. \end{aligned}$$

$T_0^\times$  is distinctly different from the subset semiring topological spaces  $T_0$  and  $T_0^+$ .

Let  $A, B \in T_{\cap}^+$  we see

$$\begin{aligned} A \cap B &= \{1, ab, b, a, ab^3, ab^5\} \cap \{a, b^2, b^3, ab^2\} \\ &= \{a\} \text{ and} \end{aligned}$$

$$\begin{aligned} A + B &= \{1, ab, b, a, ab^3, ab^5\} + \{a, b^2, b^3, ab^2\} \\ &= \{1 + a, ab + a, 2a, a + b, ab + b^2, a + b^2, ab^3 + a, \\ &\quad ab^5 + a, b^2 + 1, b + b^2, ab^3 + b^2, ab^5 + b^2, 1 + b^3, \\ &\quad ab + b^3, a + b^3, b + b^3, ab^3 + b^3, ab^5 + b^3, ab^2 + 1, \\ &\quad ab + ab^2, a + ab^2, b + ab^2, ab^3 + ab^2, ab^5 + ab^2\} \\ &\text{are in } T_{\cap}^+ \text{ and } T_{\cap}^+ \text{ is different from } T_0, T_{\cup}^+ \text{ and} \\ &T_{\cup}^{\times}. \end{aligned}$$

Now we take  $A, B \in T_{\cap}^{\times}$ ;

$$\begin{aligned} A \cap B &= \{1, ab, b, a, ab^3, ab^5\} \cap \{a, b^2, b^3, ab^2\} \\ &= \{a\} \text{ and} \end{aligned}$$

$$\begin{aligned} A \times B &= \{1, ab, b, a, ab^3, ab^5\} \times \{a, b^2, b^3, ab^2\} \\ &= \{a, b^2, b^3, ab^2, aba, ba, 1, ab^3a, ab^5a, b^2ab^3, b^3, ab^2, \\ &\quad ab^5, ab^7, ab^4, b^4, ab^3, ab^6, a, abab^2, bab^2, b^2, ab^3ab^2, \\ &\quad ab^5ab^2\} \text{ are in } T_{\cap}^{\times}. \end{aligned}$$

We see  $T_{\cap}^{\times}$  is different from  $T_0, T_{\cup}^+, T_{\cup}^{\times}$  and  $T_{\cap}^+$  as subset semiring topological spaces.

Finally let  $A, B \in T_s = \{S, +, \times\}$  we now find  $A + B$  and  $A \times B$  are in  $T_s$  and  $T_s$  is a subset semiring topological space and it is different from the subset semiring topological spaces  $T_0, T_{\cup}^+, T_{\cup}^{\times}, T_{\cap}^+$  and  $T_{\cap}^{\times}$ .

We see  $T_{\cup}^{\times}, T_{\cap}^{\times}$  and  $T_s$  are non commutative subset semiring topological spaces where as  $T_{\cup}^+, T_{\cap}^+$  and  $T_0$  are commutative subset semiring topological spaces of infinite order.

**Example 3.59:** Let  $S = \{\text{Collection of all subsets from the lattice group (group lattice) } LD_{2,5} \text{ where } L \text{ is a lattice}\}$

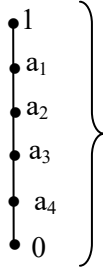

be the subset semiring.

Let  $A = \{a + b, a_3b^2, a_4b\}$  and  $B = \{a, b^2, a_1b\} \in T_0 = \{S' = S \cup \{\phi\}, \cup, \cap\}$ ;

$$A \cup B = \{a + b, a_3b^2, a_4b\} \cup \{a, b^2, a_1b\} \\ = \{a + b, a_3b^2, a_4b, a, b^2, a_1b\} \text{ and}$$

$A \cap B = \{a + b, a_3b^2, a_4b\} \cap \{a, b^2, a_1b\} \\ = \phi$  in  $T_0$  the ordinary subset topological semigroup space of  $S$ .

Let  $A, B \in T_{\cup}^+ = \{S, +, \cup\}$ .

$$A + B = \{a + b, a_3b^2, a_4b\} + \{a, b^2, a_1b\} \\ = \{a + b, a_3b^2 + a, a_4b + a, b^2 + a + b, b^2 a_4b + b^2, \\ a + b, a_3b^2 + a_1b + a_1b\}$$

and

$A \cup B = \{a + b, a_3b^2, a_4b\} \cup \{a, b^2, a_1b\} \\ = \{a + b, a_3b^2, a_4b, a, b^2, a_1b\}$  are in  $T_{\cup}^+$  and  $T_{\cup}^+$  is different from  $T_0$  as a subset semiring topological space.

Let  $A, B \in T_{\cup}^{\times}$ ; we see

$$\begin{aligned} A \cup B &= \{a + b, a_3b^2, a_4b\} \cup \{a, b^2, a_1b\} \\ &= \{a + b, a, b^2, a_3b^2, a_1b, a_4b\} \text{ and} \end{aligned}$$

$$\begin{aligned} A \times B &= \{a + b, a_3b^2, a_4b\} \times \{a, b^2, a_1b\} \\ &= \{1 + ba, a_3b^2a, a_4ba, ab^2 + b^3, a_3b^4, a_4b^3, \\ &\quad a_1ab + a_1b^2, a_3b^3, a_4a^2\} \text{ are in } T_{\cup}^{\times} \text{ and } T_{\cup}^{\times} \text{ is} \\ &\quad \text{different from } T_{\cup}^+ \text{ and } T_{\circ}. \end{aligned}$$

$$\text{Let } A, B \in T_{\cap}^+ = \{S' = S \cup \{\phi\}, \cap, +\}$$

$$\begin{aligned} A + B &= \{a + b, a_3b^2, a_4b\} + \{a, b^2, a_1b\} \\ &= \{a + b, a_3b^2 + a, a_4b + a, a + b + b^2, b^2, a_4b + b^2, \\ &\quad a_3b^2 + a_1 + a_1b\} \text{ and} \end{aligned}$$

$$\begin{aligned} A \cap B &= \{a + b, a_3b^2, a_4b\} \cap \{a, b^2, a_1b\} \\ &= \phi \text{ are in } T_{\cap}^+. \end{aligned}$$

Clearly  $T_{\cap}^+$  is different from  $T_{\circ}$ ,  $T_{\cup}^+$  and  $T_{\cup}^{\times}$  as subset semiring topological spaces of type II.

$$\text{Let } A, B \in T_{\cap}^{\times} = \{S' = S \cup \{\phi\}, \cap, \times\}$$

$$\begin{aligned} A \cap B &= \{a + b, a_3b^2, a_4b\} \cap \{a, b^2, a_1b\} \\ &= \{\phi\} \end{aligned}$$

$$\begin{aligned} A \times B &= \{a + b, a_3b^2, a_4b\} \times \{a, b^2, a_1b\} \\ &= \{1 + ba, a_3b^2a, a_4ba, ab^2 + b^3, a_3b^4, a_4b^3, a_1ab + a_1b^2, \\ &\quad a_3b^3, a_4b^2\} \text{ are in } T_{\cap}^{\times}. \end{aligned}$$

We see  $T_{\cap}^{\times}$  is different from  $T_{\cup}^{\times}$ ,  $T_{\cup}^+$ ,  $T_{\cap}^+$  and  $T_{\circ}$ .

Finally  $T_s = \{S, +, \times\}$  is a subset inherited semiring topological space of type II different from  $T_{\circ}$ ,  $T_{\cup}^+$ ,  $T_{\cap}^+$ ,  $T_{\cup}^{\times}$  and  $T_{\cap}^{\times}$ . All the 5 spaces are different for this S. Further this space is non commutative and is of finite order.

**Example 3.60:** Let  $S = \{\text{Collection of all subsets from the group semiring } (\mathbb{Z}^+ \cup \{0\}) D_{2,9}\}$  be the subset semiring of type II.

We see  $T_0, T_{\cup}^+, T_{\cup}^{\times}, T_{\cap}^+, T_{\cap}^{\times}$  and  $T_s$  are six distinct subset semiring topological spaces of infinite order.

$T_{\cup}^{\times}, T_{\cap}^{\times}$  and  $T_s$  are six distinct subset semiring topological spaces of infinite order.

$T_{\cup}^{\times}, T_{\cap}^{\times}$  and  $T_s$  are non commutative and of infinite order. However all these three subset semiring topological spaces has subspaces which are commutative.

Let  $A = \{5a + 2b + 7, 20ab^2 + 3a + 1\}$   
 and  $B = \{5b^3 + 7ab + 2, 8ab^3 + 9\} \in T_{\cup}^{\times}$  (or  $T_{\cap}^{\times}$  or  $T_s$ ), we see

$$\begin{aligned} A \times B &= \{5a + 2b + 7, 20ab^2 + 3a + 1\} \times \{5b^3 + 7ab + 2, 8ab^3 + 9\} \\ &= \{25ab^3 + 10b^4 + 35b^3 + 35b + 14bab + 49ab + 10a + 4b + 14, 100ab^5 + 15ab^3 + 5ab^3 + 140ab^2ab + 21b + 7ab + 5b^3 + 7ab + 2, 40b^3 + 16bab^3 + 56ab^3 + 45a + 18b + 63, 160ab^2ab^3 + 24b^3 + 8ab^3 + 180ab^2 + 27a + 9\} \\ &= \{25ab^3 + 10b^4 + 24a + 35b^3 + 39b + 49ab + 14, 100ab^5 + 10b^3 + 15ab^3 + 140b^9 + 14ab + 21b, 45a + 18b + 63 + 40b^3 + 16ab^2 + 56ab^3, 160b + 24b^3 + 8ab^3 + 180ab^2 + 27a + 9\} \dots I \end{aligned}$$

Consider

$$B \times A = \{5b^3 + 7ab + 2, 8ab^3 + 9\} \times \{5a + 2b + 7, 20ab^2 + 3a + 1\}$$

$$= \{25b^3a + 35aba + 10a + 10b^4 + 14ab^2 + 4b + 35b^3 + 49ab + 14, 40ab^3a + 45a + 16ab^4 + 18b + 56ab^3 + 63, 100b^3ab^2 + 140abab^2 + 40ab^2 + 15b^3a + 21aba + 6a + 5b^3 + 7ab + 2, 160ab^3ab^2 + 24ab^3a + 8ab^3 + 9 + 180ab^2 + 27a\}$$

... II

Clearly I and II are distinct so in general  $A \times B \neq B \times A$  in  $T_s$ .

(or  $T_{\cap}^{\times}$  or  $T_{\cup}^{\times}$ ). So the three spaces are non commutative.

Let  $S_1 = \{\text{Collection of all subsets from the subsemiring } P_1 = \{(3Z^+ \cup \{0\})B_1 \text{ where } B_1 = \{g \mid g^9 = 1\}\} \subseteq S$ , it is easily verified  $S_1$  is a commutative subset subsemigroup.

Further the topological subset semigroup subspaces associated with  $S$ , are commutative. All the six spaces associated with  $S_1$  is commutative and is of infinite order. Infact these spaces contain infinite number of subset subsemiring topological subspaces of  $S_1 \subseteq S$ .

**Example 3.61:** Let  $S = \{\text{Collection of all subsets from the interval semiring } [a, b] \text{ where } a, b \in Z^+ \cup \{0\}\}$  be the subset interval semiring.  $T_o, T_{\cup}^+, T_{\cup}^{\times}, T_{\cap}^+, T_{\cap}^{\times}$  and  $T_s$  the six spaces are commutative and of infinite order. Infact all these six spaces contain subspaces which are infinite in number. Take  $P_1 = \{\text{Collection of all subsets from } B_1 = \{[a, 0] \mid a \in Z^+ \cup \{0\}\}$  and  $P_2 = \{\text{Collection of all subsets from } B_2 = \{[0, b] \mid b \in Z^+ \cup \{0\}\}\}$  both  $P_1$  and  $P_2$  are subset subsemiring of  $S$ .

Also  $P_1$  and  $P_2$  are subset semiring topological subspaces of  $T_o, T_{\cup}^+, T_{\cup}^{\times}, T_{\cap}^+, T_{\cap}^{\times}$  and  $T_s$ . Further  $P_1 \times P_2 = \{[0, 0]\}$  so  $P_1$  and  $P_2$  are orthogonal subspaces of  $T_o, \dots$  and  $T_s$ . We also keep on record all these topological subset interval spaces contain infinite number of subset interval topological zero divisors.

**Example 3.62:** Let  $S = \{\text{Collection of all subsets from the interval semiring } P = \{([a_1, b_1], [a_2, b_2], [a_3, b_3], [a_4, b_4]) \mid a_i, b_i \in \mathbb{R}^+ \cup \{0\}\}\}$  be the subset interval semiring of infinite order  $S$  is commutative.

All the six subset semiring topological interval spaces  $T_o$ ,  $T_{\cup}^+$ ,  $T_{\cup}^{\times}$ ,  $T_{\cap}^+$ ,  $T_{\cap}^{\times}$  and  $T_s$  all are of infinite order, commutative and contain infinite number of subset interval topological zero divisors.

We wish to state these subset interval semiring topological spaces contain infinite number of subset interval orthogonal or annihilating subspaces.

We just say two subset semiring topological subspaces  $A$  and  $B$  of  $T_s$  ( $T_{\cup}^{\times}$ ,  $T_{\cap}^{\times}$ ) are orthogonal if  $A \times B = \{(0)\}$  and  $A$  and  $B$  are said to be annihilating subspaces of  $T_s$  (or  $T_{\cap}^{\times}$  or  $T_{\cup}^{\times}$ ).

At this point of juncture we define two subspaces  $A$  and  $B$  of  $T_s$  or  $T_{\cap}^{\times}$  or  $T_{\cup}^{\times}$  to be a direct sum of  $T_s = A + B$  and  $A \times B = (0)$ .

We first give a few illustrations before we discuss a few relevant properties.

Let  $A = \{\text{Collection of subsets from } A_1 = \{([a_1, 0], [a_2, 0], [a_3, 0], [a_4, 0]) \mid a_i \in \mathbb{R}^+ \cup \{0\}, 1 \leq i \leq 4\} \subseteq T_o$  ( $T_{\cap}^{\times}$  or  $T_{\cup}^{\times}$ ) and  $B = \{\text{Collection of all subsets from } B_1 = \{([0, b_1], [0, b_2], [0, b_3], [0, b_4]) \mid b_i \in \mathbb{R}^+ \cup \{0\}; 1 \leq i \leq 4\} \subseteq T_o$  ( $T_{\cap}^{\times}$  or  $T_{\cup}^{\times}$ ).

We see  $A$  and  $B$  are subset semiring topological subspaces and  $A \times B = \{([0, 0], [0, 0], [0, 0], [0, 0])\}$  and  $A + B = T_o$  (or  $T_{\cap}^{\times}$  or  $T_{\cup}^{\times}$ ).

Suppose in  $A$  and  $B$  if we replace  $\mathbb{R}^+ \cup \{0\}$  by  $\mathbb{Q}^+ \cup \{0\}$  or  $\mathbb{Z}^+ \cup \{0\}$  or  $n\mathbb{Z}^+ \cup \{0\}$ ;  $n \in \mathbb{N} \setminus \{1\}$  then  $A + B \neq T_s$  (or  $T_{\cap}^{\times}$  or



$T_{\cup}^{\times}$ ) only  $A + B \subseteq T_s$  (or  $T_{\cap}^{\times}$  or  $T_{\cup}^{\times}$ ) but  $A \times B = \{([0, 0], [0, 0], [0, 0], [0, 0])\}$ .

In view of this we have the following theorem.

**THEOREM 3.1:** *Let  $S = \{Collection\ of\ all\ subsets\ from\ a\ interval\ matrix\ semiring\ M\ with\ entries\ from\ Z^+ \cup \{0\}\ or\ Q^+ \cup \{0\}\ or\ R^+ \cup \{0\}\ or\ (Z^+ \cup I) \cup \{0\}\ or\ (Q^+ \cup I) \cup \{0\}\ or\ (R^+ \cup I) \cup \{0\}\}$  be the subset interval semiring. Let  $T_o, T_{\cup}^+, T_{\cup}^{\times}, T_{\cap}^+, T_{\cap}^{\times}$  and  $T_s$  be the subset interval semiring topological spaces of  $S$ .*

*If  $A, B \in T_s$  (or  $T_{\cap}^{\times}$  or  $T_{\cup}^{\times}$ ) be subset subsemiring topological subspaces of  $T_s$  (or  $T_{\cap}^{\times}$  or  $T_{\cup}^{\times}$ ) such that  $A \times B = \{0\}$  then in general  $A + B \neq T_s$  (or  $T_{\cap}^{\times}$  or  $T_{\cup}^{\times}$ ).*

The proof is direct hence left as an exercise to the reader.

However we give criteria under which the annihilating subspaces is a direct sum.

Let

$S = \{Collection\ of\ all\ subsets\ from\ a\ interval\ semiring\ P\}$  be the subset interval semiring. If  $P = A + B$  where  $A$  and  $B$  are subsemiring of  $P$  such that  $A \times B = (0)$  and by taking  $S_A = \{Collection\ of\ all\ interval\ subsets\ of\ the\ subsemiring\ A\} \subseteq S$  and  $S_B = \{Collection\ of\ all\ interval\ subsets\ of\ the\ subsemiring\ B\} \subseteq S$  then  $S_A \times S_B = \{0\}$  with  $S = S_A + S_B$ .

Now for  $S_A$  and  $S_B$  if we get subspaces of  $T_s, T_{\cap}^{\times}$  and  $T_{\cup}^{\times}$  then as subset interval topological subspaces we get them to be both orthogonal, annihilating and a direct sum.

However all annihilating subspaces or orthogonal subspaces will not lead to direct sum.

For if we take  $A = \{Collection\ of\ all\ subsets\ from\ the\ subsemiring\ P_A = \{([a_1, 0], [a_2, 0], [a_3, 0], [a_4, 0]) \mid a_i \in 5Z^+ \cup$

$\{0\} \subseteq S$  and  $B = \{\text{Collection of all subsets from the subsemiring } P_B = \{([0, b_1], [0, b_2], [0, b_3], [0, b_4]) \mid b_i \in 13Z^+ \cup \{0\}, 1 \leq i \leq 4\} \subseteq S$  are annihilating subspaces (or orthogonal subset subsemiring or subspaces of  $T_s$  or (or  $T_\cap^\times$  or  $T_\cup^\times$ ) for  $A \times B = \{([0, 0], [0, 0], [0, 0], [0, 0])\}$  but  $A + B \neq S$  (or  $T_s$  or  $T_\cap^\times$  or  $T_\cup^\times$ ).

So we cannot always attain a direct sum of orthogonal spaces.

**Example 3.63:** Let  $S = \{\text{Collection of all subsets from the semiring}$

$$P = \left\{ \left[ \begin{array}{c} [a_1, b_1] \\ [a_2, b_2] \\ \vdots \\ [a_{10}, b_{10}] \end{array} \right] \mid a_i, b_i \in Z^+ \cup \{0\}, 1 \leq i \leq 10 \right\}$$

be the subset interval matrix semiring.

$T_o, T_\cup^+, T_\cup^\times, T_\cap^+, T_\cap^\times$  and  $T_s$  be the six subset interval matrix semiring topological spaces associated with  $S$ .

These topological spaces  $T_\cap^\times, T_\cup^\times$  and  $T_s$  have infinite number of subset topological zero divisors.

Also these three spaces have infinite number of annihilating subspaces (orthogonal subspaces) however all these orthogonal subspaces may not lead to direct sum of spaces.

In view of all these we give a few more examples.

**Example 3.64:** Let  $S = \{\text{Collection of all subsets from the interval semiring}$

$$M = \left\{ \left[ \begin{array}{cccc} [a_1, b_1] & [a_2, b_2] & \dots & [a_{10}, b_{10}] \\ [a_{11}, b_{11}] & [a_{12}, b_{12}] & \dots & [a_{20}, b_{20}] \\ [a_{21}, b_{21}] & [a_{22}, b_{22}] & \dots & [a_{30}, b_{30}] \\ [a_{31}, b_{31}] & [a_{32}, b_{32}] & \dots & [a_{40}, b_{40}] \end{array} \right] \mid a_i, b_i \in Z^+ \cup \{0\}, \right. \\ \left. 1 \leq i \leq 40 \right\}$$

be the subset interval semiring of finite order. Let  $T_o, T_{\cup}^+, T_{\cup}^{\times}, T_{\cap}^+, T_{\cap}^{\times}$  and  $T_s$  be the subset interval semiring topological of  $S$ . Clearly  $T_{\cup}^{\times}, T_{\cap}^{\times}$  and  $T_s$  have infinite number of topological zero divisors and also these three spaces contain infinite number of subset interval subsemiring topological subspaces which are orthogonal (or annihilating) but may not in general lead to direct sum.

We can have several subset interval subsemiring topological subspaces say  $A_1, A_2, \dots, A_n$  such that  $A_i \times A_j = \{(0)\}$  if  $i \neq j, 1 \leq i, j \leq n$  and  $T_s (T_{\cup}^{\times} \text{ or } T_{\cap}^{\times}) = A + \dots + A_n$  and  $A_1 + \dots + A_n \subseteq T_s$  (or  $T_{\cup}^{\times}$  or  $T_{\cap}^{\times}$ ).

We will illustrate this situation using some examples.

**Example 3.65:** Let  $S = \{\text{Collection of all subsets from the interval matrix semiring}\}$

$$M = \left\{ \left[ \begin{array}{cc} [a_1, b_1] & [a_2, b_2] \\ [a_3, b_3] & [a_4, b_4] \end{array} \right] \mid a_i, b_i \in Z^+ \cup \{0\}; 1 \leq i \leq 4 \right\}$$

be the subset interval matrix semiring.  $T_o, T_{\cup}^+, T_{\cup}^{\times}, T_{\cap}^+, T_{\cap}^{\times}$  and  $T_s$  be the subset interval matrix semiring topological spaces.

We know  $T_{\cup}^{\times}, T_{\cap}^{\times}$  and  $T_s$  pave way to subset interval matrix topological spaces which has subset interval matrix topological zero divisors.

Let  $A_1 = \{\text{Collection of all subsets from the subsemiring}$

$$P_1 = \left\{ \left[ \begin{array}{cc} [0,0] & [a_1, b_1] \\ [0,0] & [0,0] \end{array} \right] \mid a_1, b_1 \in Z^+ \cup \{0\} \right\} \subseteq S,$$

$A_2 = \{\text{Collection of all subsets from the subsemiring}$

$$P_2 = \left\{ \left[ \begin{array}{cc} [a_1, b_1] & [0,0] \\ [0,0] & [0,0] \end{array} \right] \mid a_1, b_1 \in Z^+ \cup \{0\} \right\} \subseteq S,$$

$A_3 = \{\text{Collection of all subsets from the interval matrix subsemiring}$

$$P_3 = \left\{ \left[ \begin{array}{cc} [0,0] & [a_1, b_1] \\ [0,0] & [0,0] \end{array} \right] \mid a_1, b_1 \in Z^+ \cup \{0\} \right\} \subseteq S$$

and  $A_4 = \{\text{Collection of all subsets from the interval subsemiring}$

$$P_4 = \left\{ \left[ \begin{array}{cc} [0,0] & [0,0] \\ [a_1, b_1] & [0,0] \end{array} \right] \mid a_1, b_1 \in Z^+ \cup \{0\} \right\} \subseteq S$$

be the subset interval matrix subsemiring of  $S$ . These are also subset interval subsemiring topological subspaces of  $T_s$ ,  $T_{\cup}^{\times}$  and  $T_{\cap}^{\times}$ .

These subspaces are such that  $P_i \cap P_j = \left\{ \left[ \begin{array}{cc} [0,0] & [0,0] \\ [0,0] & [0,0] \end{array} \right] \right\}$ ,

$i \neq j, 1 \leq i, j \leq 4$ . Further  $T_s = P_1 + P_2 + P_3 + P_4$  is the direct sum of orthogonal or annihilating subspaces of  $T_s$  or  $T_{\cup}^{\times}$  and  $T_{\cap}^{\times}$ .

Now consider the subset interval subsemiring topological subspaces of  $T_s$  or  $T_{\cup}^{\times}$  and  $T_{\cap}^{\times}$ .

Let  $B_1 = \{\text{Collection of all subsets from the interval subsemiring}\}$

$$M_1 = \left\{ \left[ \begin{array}{cc} [a_1, b_1] & [a_2, b_2] \\ [0, 0] & [a_3, b_3] \end{array} \right] \mid a_i, b_i \in 5Z^+ \cup \{0\}; 1 \leq i \leq 3 \right\} \subseteq S.$$

$B_2 = \{\text{Collection of all subsets from the interval subsemiring}\}$

$$M_2 = \left\{ \left[ \begin{array}{cc} [0, 0] & [0, 0] \\ [a_1, b_1] & [0, 0] \end{array} \right] \mid a_1, b_1 \in 3Z^+ \cup \{0\} \right\} \subseteq S$$

we see  $B_1 + B_2 \neq S$

$$\text{but } B_1 \cap B_2 = \left\{ \left[ \begin{array}{cc} [0, 0] & [0, 0] \\ [0, 0] & [0, 0] \end{array} \right] \right\}.$$

Consider  $B_3 = \{\text{Collection of all subsets from the interval semiring}\}$

$$M_3 = \left\{ \left[ \begin{array}{cc} [0, 0] & [0, 0] \\ [a_1, b_1] & [0, 0] \end{array} \right] \mid a_1, b_1 \in 13Z^+ \cup \{0\} \right\} \subseteq S,$$

we see  $B_3 + B_1 \neq S$  but  $B_1 \cap B_3 = \left\{ \left[ \begin{array}{cc} [0, 0] & [0, 0] \\ [0, 0] & [0, 0] \end{array} \right] \right\}.$

In fact we can find infinite number of  $B_j \subseteq S$  such that

$$B_i \cap B_j = \left\{ \left[ \begin{array}{cc} [0, 0] & [0, 0] \\ [0, 0] & [0, 0] \end{array} \right] \right\} \text{ but } B_1 + B_j \subseteq S; j \in \mathbb{N} \setminus \{1\}.$$

Thus  $B_1$  is orthogonal (or annihilator) of  $B_j$  for  $j \in \mathbb{N} \setminus \{1\}$ .

**Example 3.66:** Let  $S = \{\text{Collection of all subsets from the interval super matrix semiring}\}$

$$M = \left\{ \begin{array}{c} [a_1, b_1] \\ [a_2, b_2] \\ [a_3, b_3] \\ [a_4, b_4] \\ [a_5, b_5] \\ [a_6, b_6] \\ [a_7, b_7] \\ [a_8, b_8] \end{array} \right\} \quad a_i, b_i \in \mathbb{R}^+ \cup \{0\}, 1 \leq i \leq 8 \}$$

be the subset interval super matrix semiring of infinite order.

$S$  has infinite number of subset interval super matrix subsemirings some of which are orthogonal but may not lead to direct sum.

However we have atleast a finite number of subset topological semiring subspaces which lead to direct sum.

We however illustrate a few of them.

$$\text{Take } A = \left\{ \begin{array}{c} [a_1, 0] \\ [0, 0] \\ [0, 0] \\ [0, 0] \\ [0, 0] \\ [0, 0] \\ [0, 0] \\ [0, 0] \end{array} \right\} \quad a_1 \in \mathbb{R}^+ \cup \{0\},$$

$$A_2 = \left\{ \begin{array}{c} [0, b_1] \\ [0, 0] \\ [0, 0] \\ [0, 0] \\ [0, 0] \\ [0, 0] \\ [0, 0] \\ [0, 0] \end{array} \right\} \quad b_2 \in \mathbb{R}^+ \cup \{0\} \text{ and so on.}$$

$$A_{16} = \left\{ \begin{array}{c} [0, 0] \\ [0, 0] \\ [0, 0] \\ [0, 0] \\ [0, 0] \\ [0, 0] \\ [0, 0] \\ [0, b_{16}] \end{array} \right\} \quad b_{16} \in \mathbb{R}^+ \cup \{0\}$$

are subsemiring of S.

We see  $S = A_1 + A_2 + \dots + A_{16}$  is a direct sum and

$$A_i \cap A_j = \left\{ \begin{array}{c} [0, 0] \\ [0, 0] \\ [0, 0] \\ [0, 0] \\ [0, 0] \\ [0, 0] \\ [0, 0] \\ [0, 0] \end{array} \right\} \quad \text{if } i \neq j, 1 \leq i, j \leq 16.$$

Now associated with each  $S_i$  we can have subset semiring topological  $16 \times 8$  subspaces all of which are orthogonal and lead to direct sum. We will describe one of them fully.

$${}_1T_o = S_1, {}_2T_o = S_2, \dots, {}_{16}T_o = S_{16}.$$

Similarly  ${}_i T_s, 1 \leq i \leq 16$ .

${}_i T_\cup^x, {}_i T_\cap^x, {}_i T_\cup^+$  and  ${}_i T_\cap^+$  pave way to subset semiring topological subspaces.

$$\begin{aligned} T_o &= {}_1T_o + \dots + {}_{16}T_o, \\ T_s &= {}_1T_s + \dots + {}_{16}T_s, \\ T_\cup^+ &= {}_1T_\cup^+ + \dots + {}_{16}T_\cup^+, \\ T_\cap^+ &= {}_1T_\cap^+ + \dots + {}_{16}T_\cap^+, \\ T_\cup^x &= {}_1T_\cup^x + \dots + {}_{16}T_\cup^x \text{ and} \\ T_\cap^x &= {}_1T_\cap^x + \dots + {}_{16}T_\cap^x \text{ with} \end{aligned}$$

$${}_i T_\cap^x \times {}_j T_\cap^x = \left\{ \begin{array}{c} [0,0] \\ [0,0] \\ [0,0] \\ [0,0] \\ [0,0] \\ [0,0] \\ [0,0] \\ [0,0] \end{array} \right\}$$

$$1 \leq i, j \leq 16, i \neq j.$$



$${}_i T_s \times {}_j T_s = \left\{ \begin{array}{c} [0,0] \\ [0,0] \\ [0,0] \\ [0,0] \\ \frac{[0,0]}{[0,0]} \\ [0,0] \\ [0,0] \\ [0,0] \end{array} \right\} \quad i \neq j, 1 \leq i, j \leq 16.$$

$${}_i T_\cap^\times \times {}_j T_\cap^\times = \left\{ \begin{array}{c} [0,0] \\ [0,0] \\ [0,0] \\ [0,0] \\ \frac{[0,0]}{[0,0]} \\ [0,0] \\ [0,0] \\ [0,0] \end{array} \right\} \quad 1 \leq i, j \leq 16, i \neq j.$$

$${}_i T_\cup^\times \times {}_j T_\cup^\times = \left\{ \begin{array}{c} [0,0] \\ [0,0] \\ [0,0] \\ [0,0] \\ \frac{[0,0]}{[0,0]} \\ [0,0] \\ [0,0] \\ [0,0] \end{array} \right\} \quad i \neq j, 1 \leq i, j \leq 16.$$

We see  $T_\cup^\times$ ,  $T_\cap^\times$  and  $T_s$  give way to annihilating subspace.

$$T_{\cup}^{\times} = \sum_{i=1}^{16} {}_i T_{\cup}^{\times},$$

$T_{\cap}^{\times} = \sum_{i=1}^{16} {}_i T_{\cap}^{\times}$  and  $T_s = \sum_{i=1}^{16} {}_i T_o$  are all direct sum of subset subsemiring topological subspaces of  $T_{\cup}^{\times}$ ,  $T_{\cap}^{\times}$  and  $T_s$ .

However we see S has subset subsemirings which lead to subset subsemiring topological subspaces which are orthogonal but does not lead to direct sum.

Let  ${}_i T_s = \{\text{Collection of subsets from the subsemiring}$

$$P_i = \left\{ \begin{array}{l} [0,0] \\ [0,0] \\ [0,0] \\ [a,b] \\ [0,0] \\ [d,c] \\ [0,0] \\ [e,f] \end{array} \right\} \quad a, b, c, d, e, f \in 5Z^+ \cup \{0\},$$

${}_j T_s = \{\text{Collection of all subsets from the subsemiring}$

$$P_j = \left\{ \begin{array}{l} [a,b] \\ [c,d] \\ [e,f] \\ [0,0] \\ [0,0] \\ [0,0] \\ [0,0] \\ [0,0] \end{array} \right\} \quad a, b, c, d, e, f \in 3Z^+ \cup \{0\}$$

are subtopological subspaces of  $T_s$  and

$${}_i T_s \times {}_j T_s = \left\{ \begin{matrix} [0,0] \\ [0,0] \\ [0,0] \\ [0,0] \\ [0,0] \\ [0,0] \\ [0,0] \end{matrix} \right\}; \text{ however } {}_i T_s + {}_j T_s \neq T_s$$

so only they are orthogonal but not a direct sum.

Similarly as  ${}_i T_s = {}_i T_{\cap}^{\times} = {}_i T_{\cup}^{\times}$  and  ${}_j T_s = {}_j T_{\cap}^{\times} = {}_j T_{\cup}^{\times}$  and none of them is the direct sum but they are only orthogonal or annihilates.

**Example 3.67:** Let  $S = \{\text{Collection of all subsets from the interval polynomial semiring}\}$

$$M = \left\{ \sum_{i=0}^{\infty} [a_i, b_i] x^i \mid a_i, b_i \in Z^+ \cup \{0\} \right\}$$

be the subset semiring  $T_{\circ}, T_{\cup}^+, T_{\cup}^{\times}, T_{\cap}^+, T_{\cap}^{\times}$  and  $T_s$  be the subset semiring topological spaces.

We see  $T_{\cup}^{\times}, T_{\cap}^{\times}$  and  $T_s$  can be written as a direct sum of topological subspaces which are orthogonal or annihilates each other.

Take  $L_1 = \{\text{Collection of all subsets form the subsemiring } \left\{ \sum_{i=0}^{\infty} [a_i, 0] x^i \mid a_i \in Z^+ \cup \{0\} \right\} \subseteq S$  and  $L_2 = \{\text{Collection of all subsets from the subsemiring } \left\{ \sum_{i=0}^{\infty} [0, b_i] x^i \mid b_i \in Z^+ \cup \{0\} \right\} \subseteq S$  be subset subsemirings of  $S$ .

Clearly  $L_1 + L_2 = S$  and  $L_1 \cap L_2 = \{[0, 0]\}$ .

Further if  $L_1T_s$ ,  $L_2T_s$ ,  $L_iT_\cup^\times$ ,  $L_2T_\cup^\times$ ,  $L_1T_\cap^\times$  and  $L_2T_\cap^\times$  are subset subsemiring topological subspaces we see

$$\begin{aligned} L_1T_s \times L_2T_s &= \{[0, 0]\} \\ L_1T_\cup^\times \times L_2T_\cup^\times &= \{[0, 0]\} \text{ and} \\ L_1T_\cap^\times \times L_2T_\cap^\times &= \{[0, 0]\}. \end{aligned}$$

**Example 3.68:** Let  $S = \{\text{Collection of all subsets from the polynomial ring}$

$$M = \left\{ \sum_{i=0}^{\infty} [a_i, b_i]x^i \mid a_i, b_i \in L = \right.$$

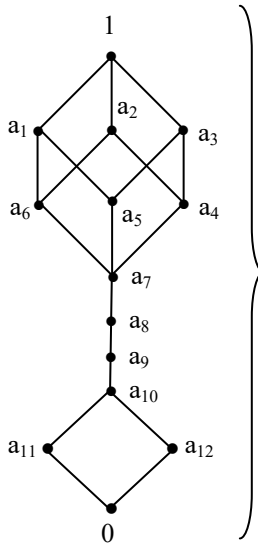

be the subset interval semiring.

This subset interval semiring is of infinite order has infinite number of subset interval zero divisors.

However  $S$  has only a finite number of subset interval idempotents. No subset non trivial interval.

**Example 3.69:** Let  $S = \{\text{Collection of all subsets from the ring}$

$$M = \left\{ \left[ \begin{array}{ccc|c} a_1 & a_2 & a_3 & a_4 \\ a_5 & a_6 & a_7 & a_8 \\ \hline a_9 & a_{10} & a_{11} & a_{12} \\ a_{13} & a_{14} & a_{15} & a_{16} \\ a_{17} & a_{18} & a_{19} & a_{20} \\ a_{21} & a_{22} & a_{23} & a_{24} \\ \hline a_{25} & a_{26} & a_{27} & a_{28} \\ a_{29} & a_{30} & a_{31} & a_{32} \end{array} \right] \right\} \quad [x_i, y_i] = a_i \in C_5 \times C_5$$

a chain lattice,  $1 \leq i \leq 12\}$ } be the finite subset interval semiring.

This has subset interval zero divisors and has no subset interval units.

This has all the six types of subset topological spaces  $T_o, T_{\cup}^+, T_{\cup}^{\times}, T_{\cap}^+, T_{\cap}^{\times}$  and  $T_s$ , all of them are of finite order.

We have the following theorem which is true in case of both subset interval semirings using ring or semirings.

**THEOREM 3.2:** *Let  $S = \{\text{Collection of all subsets from an interval ring or interval semiring}\}$  be the subset interval semiring.  $T_o, T_{\cup}^+, T_{\cup}^{\times}, T_{\cap}^+, T_{\cap}^{\times}$  and  $T_s$  be the associated topological spaces.  $T_s, T_{\cup}^{\times}$  and  $T_{\cap}^{\times}$  has a pair of subspaces  $A, B$  in  $T_s$  (or  $T_{\cup}^{\times}$  and  $T_{\cap}^{\times}$ ) such that  $A \times B = \{\text{zero space}\}$ .*

Proof is direct and hence left as an exercise to the reader.

Now we proceed onto suggest a few problems to the reader.

**Problems**

1. Discuss by interesting features enjoyed by the six topological spaces  $T_o$ ,  $T_{\cup}^+$ ,  $T_{\cup}^{\times}$ ,  $T_{\cap}^+$ ,  $T_{\cap}^{\times}$  and  $T_S$ .
2. Let  $S = \{\text{Collection of all subsets from the ring } C(\mathbb{Z}_7) \times C(\mathbb{Z}_{11})\}$  be the subset semiring of type I.

- (i) Show  $S$  has a subset subsemiring  $P (\subseteq S)$  such that  $P$  is a subset ring.
- (ii) Find  $o(S)$ .
- (iii) Can  $S$  have subset zero divisors?
- (iv) Can  $S$  have subset  $S$ -zero divisor?
- (v) Can  $S$  have subset idempotents?
- (vi) Can  $S$  have  $S$ -subset idempotents?
- (vii) Find all the subset semiring topological spaces  $T_o$ ,  $T_{\cup}^+$ ,  $T_{\cup}^{\times}$ ,  $T_{\cap}^+$ ,  $T_{\cap}^{\times}$  and  $T_S$ .
- (viii) Find atleast two subspaces of each of these topological spaces.
- (ix) Find atleast a pair of subspaces  $A, B$  in each of the three spaces  $T_o$ ,  $T_{\cup}^{\times}$ ,  $T_{\cap}^{\times}$  so that  $A \times B = \{(0, 0)\}$ .

3. Let  $S = \{\text{Collection of all subsets from the ring } R = \mathbb{Z}_{12} \times \mathbb{Z}_{30} \times \mathbb{Z}_{49}\}$  be the subset semiring.

Study questions (i) to (ix) of problem 2 for this  $S$ .

4. Let  $S = \{\text{Collection of all subsets from the matrix ring}$

$$M = \left\{ \begin{bmatrix} a_1 \\ a_2 \\ a_3 \\ a_4 \\ a_5 \\ a_6 \\ a_7 \end{bmatrix} \mid a_i \in C(\langle \mathbb{Z}_5 \cup I \rangle); 1 \leq i \leq 7 \right\}$$

be the subset semiring of the ring  $M$ .

Study questions (i) to (ix) of problem 2 for this  $S$ .

5. Let  $S = \{\text{Collection of all subsets from the ring } M = \{(a_1, a_2, a_3, a_4) \text{ where } a_i \in C(\langle Z_6 \cup I \rangle) (g_1, g_2, g_3) \text{ where } g_1^2 = 0, g_2^2 = g_2 \text{ and } g_3^2 = -g_3, g_i g_j = g_j g_i = 0 \text{ if } i \neq j, 1 \leq i, j \leq 3, ; 1 \leq i \leq 4\}\}$  be the subset semiring.

Study questions (i) to (ix) of problem 2 for this  $S$ .

6. Let  $S = \{\text{Collection of all subsets from the ring}$

$$M = \left\{ \left[ \begin{array}{cccc} a_1 & a_2 & \dots & a_6 \\ a_7 & a_8 & \dots & a_{12} \\ a_{13} & a_{14} & \dots & a_{18} \\ a_{19} & a_{20} & \dots & a_{24} \\ a_{25} & a_{26} & \dots & a_{30} \\ a_{31} & a_{32} & \dots & a_{36} \\ a_{37} & a_{38} & \dots & a_{42} \end{array} \right] \mid a_i \in Z_2 \times C(Z_5) \times C(\langle Z_7 \cup I \rangle); \right.$$

$1 \leq i \leq 42\}\}$  be the subset semiring.

Study questions (i) to (ix) of problem 2 for this  $S$ .

7. Let  $S = \{\text{Collection of all subsets from the ring}$

$$M = \left\{ \left[ \begin{array}{cccc} a_1 & a_2 & \dots & a_8 \\ a_9 & a_{10} & \dots & a_{16} \\ a_{17} & a_{18} & \dots & a_{24} \end{array} \right] \mid a \in Z_{14} \times C(Z_{10}) \times (\langle Z_7 \cup I \rangle); \right.$$

$1 \leq i \leq 24\}\}$  be the subset semiring.

Study questions (i) to (ix) of problem 2 for this  $S$ .

8. Let  $S = \{\text{Collection of all subsets from the group ring } Z_{12}S_7\}$  be subset semiring.
- (i) Study questions (i) to (ix) of problem 2 for this S.
  - (ii) Show S is non commutative.
  - (iii) Prove  $T_\cup$ ,  $T_\cap^\times$  and  $T_\cap^\times$  are non commutative topological spaces.
9. Let  $S = \{\text{Collection of all subsets from the group ring } Z_5(D_{2,7} \times S(3))\}$  be the subset semiring.
- (i) Study questions (i) to (ix) of problem 2 for this S.
  - (ii) Show S is non commutative.
  - (iii) Prove  $T_s$ ,  $T_\cup^\times$  and  $T_\cap^\times$  are non commutative as topological spaces.
10. Let  $S = \{\text{Collection of all subsets from the ring } (Z_{12} \times Z_5)(S_7 \times D_{2,5})\}$  be the subset semiring.
- (i) Study questions (i) to (ix) of problem 2 for this S.
  - (ii) Show S is non commutative.
  - (iii) Prove  $T_s$ ,  $T_\cup^\times$  and  $T_\cap^\times$  are non commutative as topological spaces.
  - (iv) Can S have right subset semiring ideals which are not left subset semiring ideals?
11. Let  $S = \{\text{Collection of all subsets from the neutrosophic group ring } C(\langle Z_7 \cup I \rangle S_5)\}$  be the subset semiring.
- (i) Study questions (i) to (ix) of problem 2 for this S
  - (ii) Prove S is non commutative.
  - (iii) Can  $T_s$ ,  $T_\cup^\times$  and  $T_\cap^\times$  have subspaces which are commutative?
  - (iv) Get at least one right subset semiring ideal of S which is not a left subset semiring ideal of S.



12. Let  $S = \{\text{Collection of all subsets from the ring}$

$$M = \left\{ \begin{bmatrix} a_1 & a_2 & a_3 & a_4 \\ a_5 & a_6 & a_7 & a_8 \\ a_9 & a_{10} & a_{11} & a_{12} \\ a_{13} & a_{14} & a_{15} & a_{16} \end{bmatrix} \middle| a_i \in C(\langle Z_7 \cup I \rangle) S_5; \right.$$

$1 \leq i \leq 16\} \}$  be the subset semiring.

- (i) Study questions (i) to (ix) of problem 2 for this  $S$ .
- (ii) Prove  $S$  is non commutative.
- (iii) Find all subspaces which are commutative in  $T_s$ ,  $T_{\cup}^{\times}$  and  $T_{\cap}^{\times}$ .

13. Let  $S = \{\text{Collection of all subsets from the ring}$

$$M = \left\{ \begin{bmatrix} a_1 & a_2 & a_3 & a_4 \\ a_5 & a_6 & a_7 & a_8 \\ a_9 & a_{10} & a_{11} & a_{12} \end{bmatrix} \middle| a_i \in Z_{12}(S_4 \times D_{2,9}); 1 \leq i \leq 12\} \}$$

be the subset semiring.

- (i) Study questions (i) to (ix) of problem 2 for this  $S$ .
- (ii) Prove  $S$  is non commutative.
- (iii) Find all subset topological semiring subspaces for  $T_s$ ,  $T_{\cup}^{\times}$  and  $T_{\cap}^{\times}$  which are non commutative.
- (iv) Find all subset semiring right ideals of  $S$  which are not subset semiring left ideals of  $S$ .

14. Let  $S = \{\text{Collection of all subsets from the matrix ring}$

$$M = \left\{ \begin{bmatrix} a_1 \\ a_2 \\ a_3 \\ a_4 \\ a_5 \\ a_6 \\ a_7 \\ a_8 \end{bmatrix} \mid a_i \in Z_7(S_3 \times D_{2,5}); 1 \leq i \leq 8 \right\}$$

be the subset semiring.

- (i) Study questions (i) to (ix) of problem 2 for this  $S$ .
- (ii) Study questions (i) to (iv) of problem 13 for this  $S$ .

15. Let  $S = \{\text{Collection of all subsets from the ring } M = \{(a_1 \mid a_2 \ a_3 \mid a_4 \ a_5 \ a_6 \ a_7) \mid C((Z_{10} \cup I))D_{2,10}; 1 \leq i \leq 7\}\}$  be the subset semiring.

- (i) Study questions (i) to (ix) of problem 2 for this  $S$ .
- (ii) Study questions (i) to (iv) of problem 13 for this  $S$ .

16. Let  $S = \{\text{Collection of all subsets from the ring } Z \times Z \times Z\}$  be the subset semiring.

- (i) Find the six spaces  $T_o, T_{\cup}^+, T_{\cup}^{\times}, T_{\cap}^+, T_{\cap}^{\times}$  and  $T_s$  associated with  $S$ .
- (ii) Find how many pairs of subspaces  $A, B$  in  $T_s, T_{\cup}^{\times}$  and  $T_{\cap}^{\times}$  exist such that  $A \times B = \{(0, 0, 0)\}$ .
- (iii) Find atleast 5 subspaces for each of these six topological spaces.

17. Let  $S = \{\text{Collection of all subsets from the ring}$

$$M = \left\{ \begin{bmatrix} a_1 & a_2 & a_3 & a_4 \\ a_5 & a_6 & a_7 & a_8 \\ a_9 & a_{10} & a_{11} & a_{12} \end{bmatrix} \mid a_i \in \mathbb{R} \times \mathbb{C}; 1 \leq i \leq 12 \right\}$$

be the subset semiring.

- (i) Study questions (i) to (iii) of problem 16 for this  $S$ .
- (ii) Find if  $S$  has  $S$ -subset zero divisors.
- (iii) Is  $S$  a  $S$ -subset semiring?
- (iv) Are the 6 topological spaces  $T_o$ ,  $T_{\cup}^+$ ,  $T_{\cup}^{\times}$ ,  $T_{\cap}^+$ ,  $T_{\cap}^{\times}$  and  $T_S$  Smarandache topological spaces?
- (v) Does these topological spaces have  $S$ -topological subspaces?

18. Let  $S = \{\text{Collection of all subsets from the ring}$

$$M = \left\{ \begin{bmatrix} a_1 & a_2 \\ a_3 & a_4 \\ a_5 & a_6 \\ a_7 & a_8 \\ a_9 & a_{10} \\ a_{11} & a_{12} \\ a_{13} & a_{14} \\ a_{15} & a_{16} \end{bmatrix} \mid a_i \in \mathbb{R} \times \langle \mathbb{R} \cup \mathbb{I} \rangle; 1 \leq i \leq 16 \right\}$$

be the subset semiring.

- (i) Study questions (i) to (iii) of problem 16 for this  $S$ .
- (ii) Study questions (i) to (v) of problem 17 for this  $S$ .

19. Let  $S = \{\text{Collection of all subsets from the ring}$

$$M = \left\{ \left[ \begin{array}{cccc} a_1 & a_2 & \dots & a_9 \\ a_{10} & a_{11} & \dots & a_{18} \end{array} \right] \mid a_i \in \langle C \cup I \rangle (g_1, g_2); g_1^2 = 0,$$

$g_2^2 = g_2, g_1g_2 = g_2g_1 = 0; 1 \leq i \leq 18\} \}$  be the subset semiring.

(i) Study questions (i) to (iii) of problem 16 for this S.

(ii) Study questions (i) to (v) of problem 17 for this S.

20. Let  $S = \{\text{Collection of all subsets from the ring}$

$$M = \left\{ \left[ \begin{array}{c} a_1 \\ a_2 \\ a_3 \\ a_4 \\ a_5 \\ a_6 \\ a_7 \\ a_8 \\ a_9 \\ a_{10} \end{array} \right] \mid a_i \in ZS_4, 1 \leq i \leq 10\} \}$$

be the subset semiring.

(i) Study questions (i) to (iii) of problem 16 for this S.

(ii) Study questions (i) to (v) of problem 17 for this S.

(iii) Prove S is non commutative.

(iv) Find all subset right semiring ideals of S which are not subset left semiring ideals of S.

(v) Find all subset semiring left ideals of S which are not subset right semiring ideals of S.

- (vi) Find all subset semiring pairs  $A, B$  of subspaces of  $T_o, T_s, T_{\cup}^+, T_{\cup}^{\times}, T_{\cap}^+$  and  $T_{\cap}^{\times}$  which are such that

$$A \times B = \left\{ \begin{matrix} \left[ \begin{matrix} 0 \\ \overline{0} \end{matrix} \right] \\ \left[ \begin{matrix} 0 \\ \overline{0} \end{matrix} \right] \\ \left[ \begin{matrix} 0 \\ \overline{0} \end{matrix} \right] \\ \left[ \begin{matrix} 0 \\ \overline{0} \end{matrix} \right] \\ \left[ \begin{matrix} 0 \\ \overline{0} \end{matrix} \right] \\ \left[ \begin{matrix} 0 \\ \overline{0} \end{matrix} \right] \\ \left[ \begin{matrix} 0 \\ \overline{0} \end{matrix} \right] \\ \left[ \begin{matrix} 0 \\ \overline{0} \end{matrix} \right] \\ \left[ \begin{matrix} 0 \\ \overline{0} \end{matrix} \right] \\ \left[ \begin{matrix} 0 \\ \overline{0} \end{matrix} \right] \end{matrix} \right\}.$$

21. Let  $S = \{\text{Collection of all subsets from the ring}$

$$M = \left\{ \left[ \begin{array}{cccc|cc|cc} a_1 & a_2 & a_3 & a_4 & a_5 & a_6 & a_7 & a_8 \\ a_9 & a_{10} & \dots & \dots & \dots & \dots & a_{15} & a_{16} \\ \hline a_{17} & a_{18} & & & & & a_{23} & a_{24} \\ a_{25} & a_{26} & & & & & a_{31} & a_{32} \\ \hline a_{33} & a_{34} & & & & & a_{39} & a_{40} \end{array} \right] \mid a_i \in \dots \right\}$$

$\langle Q \cup I \rangle, 1 \leq i \leq 40 \}$  be the subset semiring.

- (i) Study questions (i) to (iii) of problem 16 for this  $S$ .
  - (ii) Study questions (i) to (v) of problem 17 for this  $S$ .
  - (iii) Study questions (i) to (vi) of problem 20 for this  $S$ .
22. Let  $S = \{\text{Collection of all subsets from the polynomial ring } \langle (R \cup I)[x] \rangle\}$  be the subset semiring.
- (i) Study questions (i) to (iii) of problem 16 for this  $S$ .

- (ii) Can  $T_o, T_s, T_{\cup}^+, T_{\cup}^{\times}, T_{\cap}^+$  and  $T_{\cap}^{\times}$  have subset topological zero divisors?
- (iii) Can  $S$  have subset idempotents?
- (iv) Prove  $S$  has infinite collection of subset semiring ideals.

23. Let  $S = \{\text{Collection of all subsets form the ring } M = \{([a_1, b_1], [a_2, b_2], \dots, [a_5, b_5]) \mid a_i, b_i \in \mathbb{Z}; 1 \leq i \leq 5\}\}$  be the subset semiring.

- (i) Study questions (i) to (iii) of problem 16 for this  $S$ .
- (ii) Study questions (i) to (v) of problem 17 for this  $S$ .
- (iii) How many subset pair wise subtopological subspaces  $A, B$  in  $T_o, T_s, T_{\cup}^+, T_{\cup}^{\times}, T_{\cap}^+$  and  $T_{\cap}^{\times}$  exist such that  $A \times B = \{([0, 0], [0, 0], [0, 0], [0, 0], [0, 0])\}$ .

24. Let  $S = \{\text{Collection of all subsets from the ring}$

$$M = \left\{ \begin{bmatrix} [a_1, b_1] & [a_2, b_2] & \dots & [a_5, b_5] \\ [a_6, b_6] & [a_7, b_7] & \dots & [a_{10}, b_{10}] \\ \vdots & \vdots & & \vdots \\ [a_{21}, b_{21}] & [a_{22}, b_{22}] & \dots & [a_{25}, b_{25}] \end{bmatrix} \right\} a_i \in \langle \mathbb{R} \cup I \rangle$$

$(g_1, g_2, g_3)$  where  $g_1^2 = 0, g_2^2 = g_2, g_3^2 = -g_3, g_i g_j = g_j g_i = 0, i \neq j, 1 \leq i, j \leq 3; 1 \leq i \leq 25\}$  be the subset semiring.

- (i) Study questions (i) to (iii) of problem 16 for this  $S$ .
- (ii) Study questions (i) to (v) of problem 17 for this  $S$ .

- (iii) How many subset pair wise subtopological subspaces  $A, B$  in  $T_o, T_s, T_\cup^+, T_\cup^\times, T_\cap^+$  and  $T_\cap^\times$  exists such that  $A \times B = \{([0,0])_{5 \times 5}\}$ .

25. Let  $S = \{\text{Collection of all subsets from the ring}$

$$M = \left\{ \left[ \begin{array}{ccc} [a_1, b_1] & \dots & [a_{10}, b_{10}] \\ [a_{11}, b_{11}] & \dots & [a_{20}, b_{20}] \\ [a_{21}, b_{21}] & \dots & [a_{30}, b_{30}] \end{array} \right] \mid a_i \in \langle Z \cup I \rangle S_3; \right.$$

$1 \leq i \leq 30\} \}$  be the subset semiring.

- (i) Study questions (i) to (iii) of problem 16 for this  $S$ .  
 (ii) Study questions (i) to (v) of problem 17 for this  $S$ .  
 (iii) How many subset pair wise subtopological subspaces  $A, B$  in  $T_o, T_s, T_\cup^+, T_\cup^\times, T_\cap^+$  and  $T_\cap^\times$  exists such that  $A \times B = \{(0)\}$ ?

26. Let  $S = \{\text{Collection of all subsets from the interval matrix}$

$$\text{ring } M = \left\{ \left[ \begin{array}{c} [a_1, b_1] \\ [a_2, b_2] \\ [a_3, b_3] \\ [a_4, b_4] \\ [a_5, b_5] \\ [a_6, b_6] \\ [a_7, b_7] \\ [a_8, b_8] \\ [a_9, b_9] \end{array} \right] \mid a_i, b_i \in R(S_3 \times D_{2,7}); 1 \leq i \leq 9 \right\}$$

be the subset semiring.

- (i) Study questions (i) to (iii) of problem 16 for this  $S$ .  
 (ii) Study questions (i) to (v) of problem 17 for this  $S$ .

(iii) How many subset pairwise subtopological subspaces  $A, B$  in  $T_o, T_S, T_\cup^+, T_\cup^\times, T_\cap^+$  and  $T_\cap^\times$  exist such that  $A \times B = \{(0)\}$ ?

27. Let  $S = \{\text{Collection of all subsets form the interval matrix ring } \{([a_1, b_1], [a_2, b_2], [a_3, b_3], \dots, [a_9, b_9]) \text{ where } a_i, b_i \in \langle \mathbb{Z} \cup I \rangle (D_{2,4} \times S_7); 1 \leq i \leq 9\}\}$  be the subset semiring.

(i) Study questions (i) to (iii) of problem 16 for this  $S$ .

(ii) Study questions (i) to (v) of problem 17 for this  $S$ .

(iii) How many subset pairwise subtopological subspaces  $A, B$  in  $T_o, T_S, T_\cup^+, T_\cup^\times, T_\cap^+$  and  $T_\cap^\times$  exist such that  $A \times B = \{(0)\}$ ?

28. Let  $S = \{\text{Collection of all subsets from the ring}$

$$M = \left\{ \begin{bmatrix} [a_1, b_1] & [a_2, b_2] & [a_3, b_3] \\ [a_4, b_4] & [a_5, b_5] & [a_6, b_6] \\ [a_7, b_7] & [a_8, b_8] & [a_9, b_9] \end{bmatrix} \right\} \quad a_i, b_i \in$$

$\langle \mathbb{R} \cup I \rangle (S(9)); 1 \leq i \leq 9\}$  be the subset semiring.

(i) Study questions (i) to (iii) of problem 16 for this  $S$ .

(ii) Study questions (i) to (v) of problem 17 for this  $S$ .

(iii) How many subset pairwise subtopological subspaces  $A, B$  in  $T_o, T_S, T_\cup^+, T_\cup^\times, T_\cap^+$  and  $T_\cap^\times$  exist such that  $A \times B = \{(0)\}$ .



29. Let  $S = \{\text{Collection of all subsets from the ring}$

$$M = \left\{ \begin{bmatrix} [a_1, b_1] & [a_2, b_2] & [a_3, b_3] & [a_4, b_4] & [a_5, b_5] \\ [a_6, b_6] & \dots & \dots & \dots & [a_{10}, b_{10}] \\ [a_{11}, b_{11}] & \dots & \dots & \dots & [a_{15}, b_{15}] \\ [a_{16}, b_{16}] & \dots & \dots & \dots & [a_{20}, b_{20}] \end{bmatrix} \right\} a_i,$$

$b_i \in \langle Q \cup I \rangle (S_3 \times A_4 \times D_{2,15}); 1 \leq i \leq 20\}$  be the subset semiring.

- (i) Study questions (i) to (iii) of problem 16 for this S.
- (ii) Study questions (i) to (v) of problem 17 for this S.
- (iii) How many subset pairwise subtopological subspaces  $A, B$  in  $T_o, T_s, T_\cup^+, T_\cup^\times, T_\cap^+$  and  $T_\cap^\times$  exists such that  $A \times B = \{(0)\}$ ?

30. Let  $S = \{\text{Collection of all subsets from the ring}$

$$M = \left\{ \begin{bmatrix} [a_1, b_1] & [a_2, b_2] & [a_3, b_3] \\ [a_4, b_4] & [a_5, b_5] & [a_6, b_6] \\ [a_7, b_7] & [a_8, b_8] & [a_9, b_9] \\ [a_{10}, b_{10}] & [a_{11}, b_{11}] & [a_{12}, b_{12}] \\ [a_{13}, b_{13}] & [a_{14}, b_{14}] & [a_{15}, b_{15}] \\ [a_{16}, b_{16}] & [a_{17}, b_{17}] & [a_{18}, b_{18}] \\ [a_{19}, b_{19}] & [a_{20}, b_{20}] & [a_{21}, b_{21}] \end{bmatrix} \right\} a_i, b_i \in \langle Q \cup I \rangle$$

$(S(5) \times A_7); 1 \leq i \leq 21\}$  be the subset semiring.

- (i) Study questions (i) to (iii) of problem 16 for this S.
- (ii) Study questions (i) to (v) of problem 17 for this S.
- (iii) How many subset pairwise topological subspaces  $A, B$  in  $T_\cap^\times$  (or  $T_s, T_\cup^\times$ ) exist such that  $A \times B = \{(0)\}$ ?

31. Obtain some special features enjoyed by the annihilating subset topological subspaces and subset topological zero divisors of  $T_S$ ,  $T_{\cup}^{\times}$  and  $T_{\cap}^{\times}$ .
32. Obtain some special features enjoyed by the four types of subset semiring topological spaces of type II when the spaces are finite and non commutative.
33. Let  $S = \{\text{Collection of all subsets from the semiring } Z^+ \cup \{0\}\}$  be the subset semiring.
  - (i) Find the 6 topological subspaces  $T_o$ ,  $T_S$ ,  $T_{\cup}^+$ ,  $T_{\cup}^{\times}$ ,  $T_{\cap}^+$  and  $T_{\cap}^{\times}$  and find atleast 3 subspaces in each of them.
  - (ii) Can these topological spaces have subset topological zero divisors?
  - (iii) Can S have subset units?
  - (iv) Prove all the six spaces have infinite number of subspaces.
34. Let  $S = \{\text{Collection of all subsets from the semiring } Z^+ \cup \{0\} \times Z^+ \cup \{0\} \times Z^+ \cup \{0\}\}$  be the subset semiring.
  - (i) Study questions (i) to (iv) problem 33 for this S.
35. Let  $S = \{\text{Collection of all subsets from the semiring } Q^+ \cup \{0\} \times Z^+ \cup \{0\} \times R^+ \cup \{0\}\}$  be the subset semiring.
 

Study questions (i) to (iv) problem 33 for this S.
36. Let  $S = \{\text{Collection of all subsets from the semiring } \langle Z^+ \cup I \rangle \cup \{0\} \times \langle Z^+ \cup \{0\} \rangle \cup \{0\}\}$  be the subset semiring.
  - (i) Study questions (i) to (iv) problem 33 for this S.
  - (ii) Can S have subset idempotents?

- (iii) Prove  $T_S$ ,  $T_{\cup}^{\times}$  and  $T_{\cap}^{\times}$  have pairs of subspaces  $A, B$  such that  $A \times B = \{(0, 0)\}$ .

37. Let  $S = \{\text{Collection of all subsets from the semiring}$

$$M = \left\{ \left[ \begin{array}{c} a_1 \\ a_2 \\ a_3 \\ a_4 \\ a_5 \\ a_6 \\ a_7 \\ a_8 \end{array} \right] \mid a_i \in \langle \mathbb{Z}^+ \cup I \rangle \cup \{0\}; 1 \leq i \leq 8 \right\}$$

be the subset semiring.

- (i) Study questions (i) to (iv) of problem 33 for this  $S$ .
- (ii) Study questions (i) to (iii) of problem 37 for this  $S$ .

38. Let  $S = \{\text{Collection of all subsets from the semiring } (\mathbb{Z}^+ \cup \{0\}) S(5)\}$  be the subset semiring.

- (i) Study questions (i) to (iv) problem 33 for this  $S$ .
- (ii) Prove  $S$  is a non commutative subset semiring.
- (iii) Prove  $T_S$ ,  $T_{\cup}^{\times}$  and  $T_{\cap}^{\times}$  are non commutative topological spaces.
- (iv) Find all subsets topological subspaces of  $T_S$ ,  $T_{\cup}^{\times}$  and  $T_{\cap}^{\times}$  which are commutative.
- (v) Find those subset right semiring ideals which are not subset left semiring ideals.
- (vi) Can  $S$  have  $S$ -subset units?

39. Let  $S = \{\text{Collection of all subsets from the semiring } (\mathbb{Z}^+ \cup \{0\}) (S(7) \times D_{2,5})\}$  be the subset semiring.

- (i) Study questions (i) to (iv) problem 33 for this S.
- (ii) Study questions (i) to (vi) problem 38 for this S.

40. Let  $S = \{\text{Collection of all subsets from the matrix}$

$$\text{semiring } M = \left\{ \begin{bmatrix} a_1 & a_2 & a_3 \\ a_4 & a_5 & a_6 \\ \vdots & \vdots & \vdots \\ a_{13} & a_{14} & a_{15} \end{bmatrix} \right\} \text{ where } a_i \in (Z^+ \cup \{0\})$$

$S(4); 1 \leq i \leq 15\}$ .

- (i) Study questions (i) to (iv) problem 33 for this S.
- (ii) Study questions (i) to (vi) problem 38 for this S.
- (iii) Find any other special property enjoyed by S.

41. Let  $S = \{\text{Collection of all subsets from the matrix semiring } M = \{(a_1, a_2, \dots, a_{10}) \mid a_i \in ((Q^+ \cup I) \cup \{0\})_{D_{2,5}}; 1 \leq i \leq 10\}\}$  be the subset semiring.

- (i) Study questions (i) to (iv) problem 33 for this S.
- (ii) Study questions (i) to (vi) problem 38 for this S.

42. Let  $S = \{\text{collection of all subsets from the semiring}$

$$M = \left\{ \begin{bmatrix} a_1 & a_2 & a_3 & a_4 & a_5 & a_6 \\ a_7 & a_8 & a_9 & a_{10} & a_{11} & a_{12} \\ a_{13} & a_{14} & a_{15} & a_{16} & a_{17} & a_{18} \end{bmatrix} \right\} a_i \in ((Q^+ \cup I) \cup$$

$\{0\}); 1 \leq i \leq 18\}$  be the subset semiring.

- (i) Study questions (i) to (iv) problem 33 for this S.
- (ii) Study questions (i) to (vi) problem 38 for this S.

43. Let  $S = \{\text{Collection of all subsets from the matrix}$

$$\text{semiring } M = \left\{ \left[ \begin{array}{cccc} a_1 & a_2 & \dots & a_7 \\ a_8 & a_9 & \dots & a_{14} \\ \vdots & \vdots & & \vdots \\ a_{43} & a_{44} & \dots & a_{49} \end{array} \right] \middle| a_i \in ((Q^+ \cup I)) \cup \right.$$

$\{0\} \} (S_4 \times A_5) \} \}$  be the subset semiring.

(i) Study questions (i) to (iv) problem 33 for this  $S$ .

(ii) Study questions (i) to (vi) problem 38 for this  $S$ .

44. Let  $S = \{\text{Collection of all subsets from the matrix}$

$$\text{semiring } M = \left\{ \left[ \begin{array}{cccc} a_1 & a_2 & a_3 & a_4 \\ a_5 & a_6 & a_7 & a_8 \\ \vdots & \vdots & & \vdots \\ a_{41} & a_{42} & a_{43} & a_{44} \end{array} \right] \middle| a_i \in ((Q^+ \cup I)) \cup \right.$$

$\{0\} \} D_{2,11}; 1 \leq i \leq 44 \} \}$  be the subset semiring.

(i) Study questions (i) to (iv) problem 33 for this  $S$ .

(ii) Study questions (i) to (vi) problem 38 for this  $S$ .

45. Let  $S = \{\text{Collection of all subsets from the super matrix}$

$$\text{semiring } M = \left\{ \left[ \begin{array}{c} a_1 \\ a_2 \\ a_3 \\ a_4 \\ a_5 \\ a_6 \\ a_7 \\ a_8 \\ a_9 \\ a_{10} \\ a_{11} \\ a_{12} \\ a_{13} \end{array} \right] \mid a_i \in (Z^+ \cup I) S_7; 1 \leq i \leq 13 \right\} \text{ be}$$

the subset semiring.

- (i) Study questions (i) to (iv) problem 33 for this S.
- (ii) Study questions (i) to (vi) problem 38 for this S.

46. Let  $S = \{\text{Collection of all subsets from the semiring } M = \{(a_1 \mid a_2 \ a_3 \mid a_4 \ a_5 \ a_6 \mid a_7 \mid a_8 \ a_9 \ a_{10} \ a_{11}) \mid a_i \in ((Q^+ \cup I) \cup \{0\}) D_{2,7}; 1 \leq i \leq 11\}\}$  be the subset semiring.

- (i) Study questions (i) to (iv) problem 33 for this S.
- (ii) Study questions (i) to (vi) problem 38 for this S.

47. Let  $S = \{\text{Collection of all subsets from the semiring}$

$$P = \left\{ \left[ \begin{array}{c|c|c|c} a_1 & a_2 & a_3 & a_4 \\ \hline a_5 & a_6 & a_7 & a_8 \\ \hline a_9 & a_{10} & a_{11} & a_{12} \\ \hline a_{13} & a_{14} & a_{15} & a_{16} \\ \hline a_{17} & a_{18} & a_{19} & a_{20} \\ \hline a_{21} & a_{22} & a_{23} & a_{24} \end{array} \right] \mid a_i \in ((\mathbb{R}^+ \cup I)) \cup \{0\} \right\}$$

$(D_{2,5} \times A_4); 1 \leq i \leq 24\}$  be the subset semiring.

(i) Study questions (i) to (iv) problem 33 for this  $S$ .

(ii) Study questions (i) to (vi) problem 38 for this  $S$ .

48. Let  $S = \{\text{Collection of all subsets from the polynomial semiring } [(\mathbb{R}^+ \cup I) \cup \{0\}][x]\}$  be the subset semiring.

(i) Find  $T_o, T_S, T_{\cup}^+, T_{\cup}^{\times}, T_{\cap}^+$  and  $T_{\cap}^{\times}$  of  $S$ .

(ii) Can  $T_S, T_{\cup}^{\times}$  and  $T_{\cap}^{\times}$  have subset topological zero divisors?

(iii) Find any other special property enjoyed by  $S$ .

49. Let  $S = \{\text{Collection of all subsets from the polynomial ring } (\mathbb{R}^+ \cup \{0\}) (S_3 \times A_4 \times D_{2,7})[x]\}$  be the subset non commutative semiring.

(i) Study questions (i) to (iv) problem 33 for this  $S$ .

(ii) Study questions (i) to (vi) problem 38 for this  $S$ .

50. Let  $S = \{\text{Collection of all subsets from the semiring}\}$

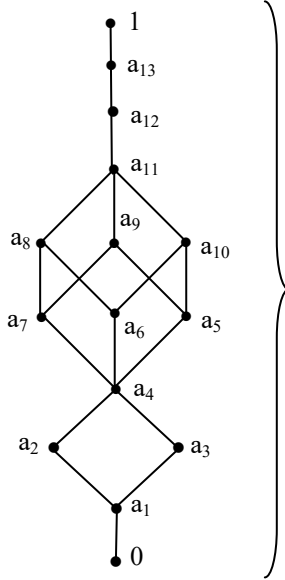

be the subset semiring.

- (i) Find  $o(S)$ .
- (ii) Find  $T_o, T_s, T_{\cup}^+, T_{\cup}^{\times}, T_{\cap}^+$  and  $T_{\cap}^{\times}$  of  $S$ .
- (iii) Find all subset zero divisors of  $S$ .
- (iv) Find all subset idempotents of  $S$ .
- (v) Can  $T_s, T_{\cup}^{\times}$  and  $T_{\cap}^{\times}$  have subset topological zero divisors?
- (vi) Find subtopological spaces  $A, B \in T_s$  (or  $T_{\cup}^{\times}$  or  $T_{\cap}^{\times}$ ) such that  $A \times B = \{0\}$ .



51. Let  $S = \{\text{Collection of all subsets from the semiring } P =$

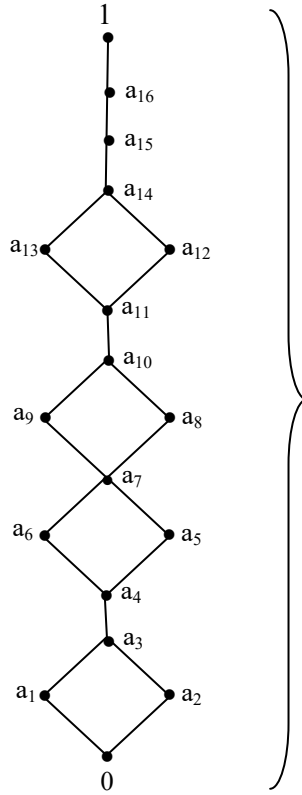

be the subset semiring.

Study questions (i) to (vi) problem 50 for this S.

52. Let  $S = \{\text{Collection of all subsets from the semiring } L_1 \times L_2 \text{ where}$

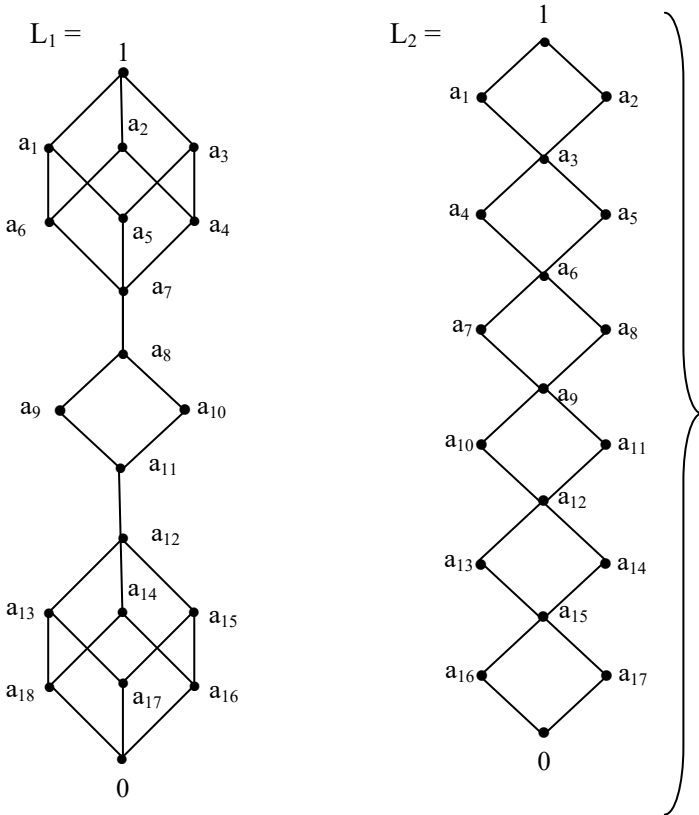

be the subset semiring.

Study questions (i) to (vi) problem 50 for this  $S$ .

53. Let  $S = \{\text{Collection of all subsets from the semiring } LS_4 \text{ where } L =$

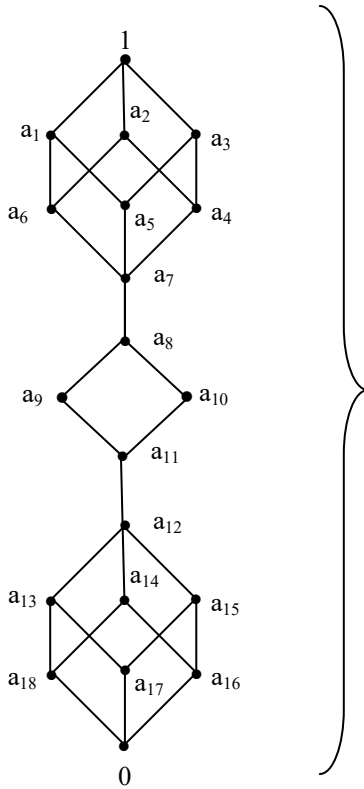

be the subset semiring.

- (i) Study questions (i) to (vi) problem 50 for this  $S$ .
  - (ii) Prove  $S$  is non commutative.
  - (iii) Find all left subset semiring ideals which are not right subset semiring ideal of  $S$ .
54. Let  $S = \{\text{Collection of all subsets from the semiring } L(S_3 \times A_4) \text{ where } L =$

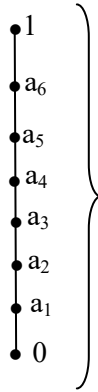

be the subset semiring.

- (i) Study questions (i) to (vi) problem 50 for this S.
- (ii) Prove S is non commutative.
- (iii) Find all subset units in S.
- (iv) Find all left subset semiring ideals which are not right subset semiring ideals of S.

55. Let  $S = \{\text{Collection of all subsets from the semiring}$

$$M = \left\{ \left[ \begin{array}{cccc} a_1 & a_2 & a_3 & a_4 \\ a_5 & a_6 & a_7 & a_8 \\ a_9 & a_{10} & a_{11} & a_{12} \end{array} \right] \mid a_i \in LS_4 \right\}$$

where L is the lattice

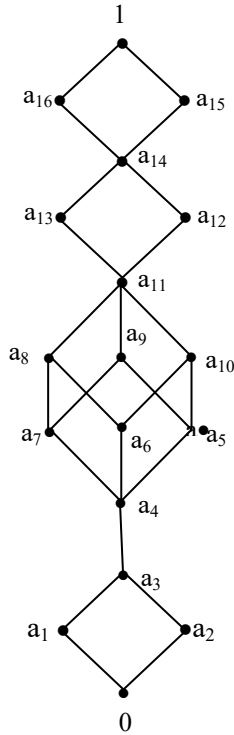

$1 \leq i \leq 12\}$  be the subset semiring.

- (i) Study questions (i) to (vi) problem 49 for this S.
- (ii) Find the number of subset zero divisors in S.
- (iii) Can S has S-subset zero divisors?
- (iv) Is it possible for S to have subset units?
- (v) Find all subset right semiring ideals which are not left semiring ideal of S.
- (vi) Find the number of subset idempotents in S.
- (vii) Can S have subset Smarandache idempotents?

56. Let  $S = \{\text{Collection of all subsets from the matrix semiring}\}$

$$M = \left\{ \begin{bmatrix} a_1 & a_2 & a_3 \\ a_4 & a_5 & a_6 \\ \vdots & \vdots & \vdots \\ a_{28} & a_{29} & a_{30} \end{bmatrix} \mid a_i \in LD_{2,11}; 1 \leq i \leq 30 \text{ and } L = A \right\}$$

Boolean algebra of order 32} be the subset semiring.

- (i) Study questions (i) to (vi) problem 50 for this S.
- (ii) Can S have subset S-zero divisors?
- (iii) Can S have S-subset idempotents?

57. Let  $S = \{ \text{Collection of all subsets from matrix semiring } M = \{ \text{Collection of all } 8 \times 8 \text{ matrix with entries form } (L_1 \times L_2) A_5 \} \}$  be the subset semiring;

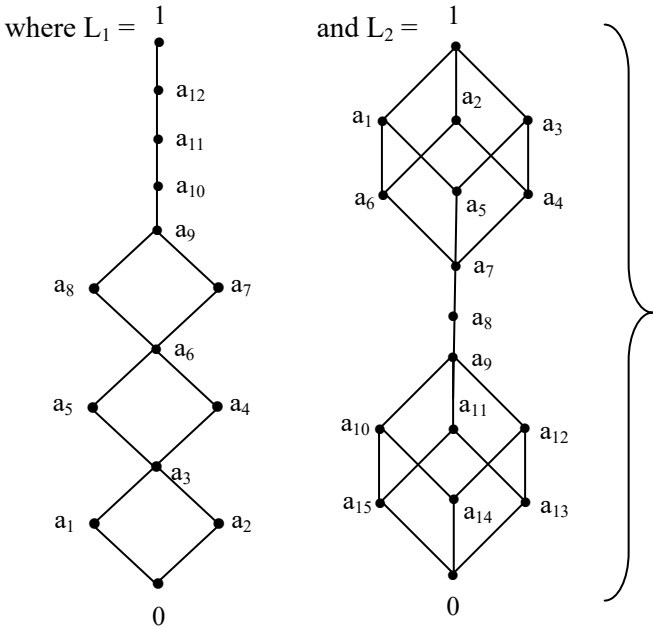

- (i) Find all subset zero divisors of S.
- (ii) Can S have subset idempotents?
- (iii) Can S have S-subset zero divisors?
- (iv) Can S have S-subset idempotents?

- (v) Study questions (i) to (vi) problem 50 for this S.
- (vi) Find all subset units of S.
- (vii) Is it possible S contains S-subset units?

58. Let  $S = \{\text{Collection of all subsets from the super matrix semiring } M = \{(a_1 | a_2 a_3 a_4 | a_5 a_6 a_7 a_8 | a_9 a_{10}) \mid a_i \in L (S_6 \times D_{2,5}); 1 \leq i \leq 10\}\}$  be the subset semiring where L is a Boolean algebra of order 64.

- (i) Study questions (i) to (vi) problem 50 for this S.
- (ii) Can S have S-subset units?
- (iii) Can S have S-subset idempotents?
- (iv) How many subset idempotents of S exist?
- (v) Can S have S-subset zero divisors?
- (vi) Can S have S-subset ideals?
- (vii) Find the number of subset zero divisors of S.

59. Let  $S = \{\text{Collection of all subsets from the super matrix}$

$$\text{semiring } M = \left\{ \left[ \begin{array}{cc} a_1 & a_2 \\ a_3 & a_4 \\ a_5 & a_6 \\ a_7 & a_8 \\ \hline a_9 & a_{10} \\ a_{11} & a_{12} \\ a_{13} & a_{14} \\ a_{15} & a_{16} \\ a_{17} & a_{18} \\ \hline a_{19} & a_{20} \\ a_{21} & a_{22} \end{array} \right] \mid a_i \in LA_6, 1 \leq i \leq 22 \right\} \text{ be the}$$

subset semiring. The lattice L is the chain lattice  $C_{25}$ .

- (i) Study questions (i) to (vii) problem 58 for this S.

60. Let  $S = \{\text{Collection of all subsets from the semiring}$

$$P = \left\{ \begin{array}{c|c|c|c|c} \begin{array}{c} a_1 \quad a_2 \quad a_3 \\ a_{10} \quad \dots \quad \dots \\ a_{19} \quad \dots \quad \dots \\ \hline a_{28} \quad \dots \quad \dots \\ a_{37} \quad \dots \quad \dots \\ \hline a_{46} \quad \dots \quad \dots \\ a_{55} \quad \dots \quad \dots \\ a_{64} \quad \dots \quad \dots \\ \hline a_{73} \quad a_{74} \quad a_{75} \end{array} & \begin{array}{c} a_4 \quad a_5 \\ \dots \quad \dots \\ \dots \quad \dots \\ \hline \dots \quad \dots \\ \dots \quad \dots \\ \hline \dots \quad \dots \\ \dots \quad \dots \\ \hline a_{76} \quad a_{77} \end{array} & \begin{array}{c} a_6 \quad a_7 \quad a_8 \\ \dots \quad \dots \quad \dots \\ \dots \quad \dots \quad \dots \\ \hline \dots \quad \dots \quad \dots \\ \dots \quad \dots \quad \dots \\ \hline \dots \quad \dots \quad \dots \\ \dots \quad \dots \quad \dots \\ \hline a_{78} \quad a_{79} \quad a_{80} \end{array} & \begin{array}{c} a_9 \\ a_{18} \\ a_{27} \\ \hline a_{36} \\ a_{45} \\ \hline a_{54} \\ a_{63} \\ a_{70} \\ \hline a_{81} \end{array} \end{array} \right\} a_i$$

$\in L(S_3 \times D_{2,7}); 1 \leq i \leq 81\}$  where  $L$  is a lattice which is as follows:

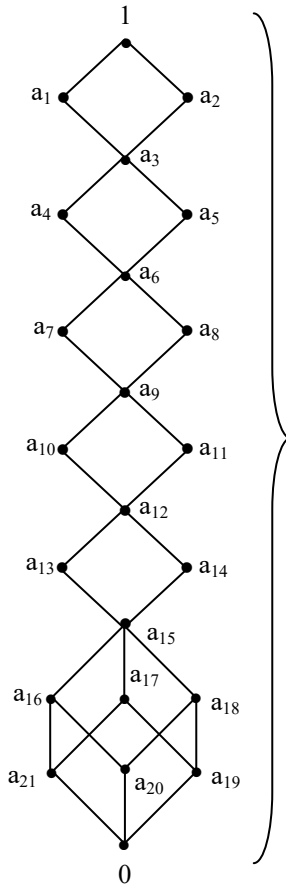



be the subset semiring.

(i) Study questions (i) to (vii) problem 58 for this S.

61. Let  $S = \{\text{Collection of all subsets from the semiring}$

$$P = \left\{ \left( \begin{array}{cccc|ccc|cc|c} a_1 & a_2 & a_3 & a_4 & a_5 & a_6 & a_7 & a_8 & a_9 & a_{10} \\ a_{11} & \dots & \dots & \dots & \dots & \dots & \dots & \dots & \dots & a_{20} \\ a_{21} & \dots & \dots & \dots & \dots & \dots & \dots & \dots & \dots & a_{30} \end{array} \right) \right\} a_i$$

$\in L(S_3 \times D_{2,11}); 1 \leq i \leq 30\}$  where  $L =$

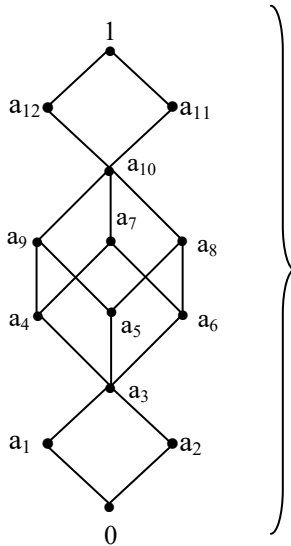

be the subset semiring.

(i) Study questions (i) to (vii) problem 58 for this S.

62. Let  $S = \{\text{Collection of all subsets from the semiring}$

$$M = \left\{ \begin{array}{|c|c|} \hline a_1 & a_2 \\ \hline a_3 & a_4 \\ \hline a_5 & a_6 \\ a_7 & a_8 \\ \hline a_9 & a_{10} \\ a_{11} & a_{12} \\ \hline a_{13} & a_{14} \\ a_{15} & a_{16} \\ \hline a_{17} & a_{18} \\ a_{19} & a_{20} \\ \hline \end{array} \right\}$$

$a_i \in (L_1 \times L_2)D_{2,10}$  where  $L_1 =$

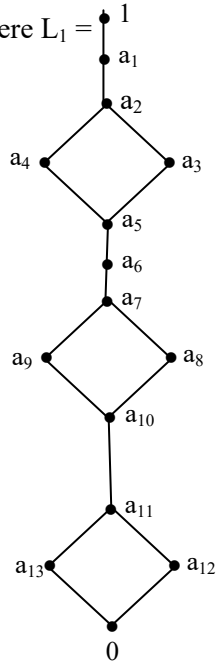

and  $L_2$  is a Boolean algebra of order  $64, 1 \leq i \leq 20\}$  be the subset semiring.

(i) Study questions (i) to (vii) problem 58 for this  $S$ .

63. Let  $S = \{\text{Collection of all subsets from the lattice polynomial semiring } P = \left\{ \sum_{i=0}^{\infty} a_i x^i \mid a_i \in L \text{ where } L = \right.$

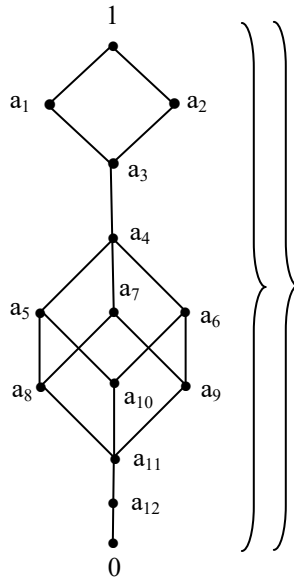

be the subset semiring which is commutative.

- (i) Show  $S$  is of infinite order.
  - (ii) Study questions (i) to (vii) problem 58 for this  $S$ .
63. Let  $S = \{\text{Collection of all subsets from the semiring } P = \left\{ \sum_{i=0}^{\infty} a_i x^i \mid a_i \in LS_5 \text{ where } L \text{ is a Boolean algebra of order } 64\} \}$  be the subset semiring.

Study questions (i) to (vii) problem 58 for this  $S$ .

64. Let  $S = \{\text{Collection of all subsets from the semiring } B = \left\{ \sum_{i=0}^{\infty} a_i x^i \mid a_i \in L (S(3) \times D_{2,5}) \text{ where } L \text{ is a lattice} \right.$

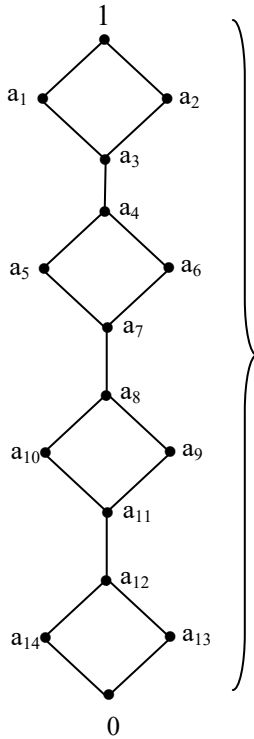

be the subset semiring.

Study questions (i) to (vii) problem 58 for this S.

65. Let  $S = \{\text{Collection of all subsets from the interval semiring } P = \{[a, b] \mid a, b \in \mathbb{Z}^+ \cup \{0\}\}\}$  be the subset semiring.

- (i) Find all subset subsemirings of S which are not subset semiring ideals.
- (ii) Can S be a S-subset semiring?
- (iii) Can S have subset zero divisors?
- (iv) Show S has infinite number of pairs A, B of subset semiring ideals such that  $A \times B = \{[0, 0]\} = (\text{zero of S})$ .

(v) Find all the six interval subset topological semiring spaces  $T_0, T_{\cup}^+, T_{\cup}^{\times}, T_{\cap}^+, T_{\cap}^{\times}$  and  $T_S$  and show  $T_{\cup}^{\times}, T_{\cap}^{\times}$  and  $T_S$  has infinite number of pairs of topological subspaces  $C, D$  such that  $C \times D = \{[0, 0]\} = (\text{zero of } S)$ .

66. Let  $S = \{\text{Collection of all subsets from the interval matrix semiring } M = \{([a_1, b_1], [a_2, b_2], [a_3, b_3]) \mid a_i, b_i \in \langle \mathbb{Q}^+ \cup I \cup \{0\} \rangle, 1 \leq i \leq 3\}\}$  be the subset semiring.

(i) Study questions (i) to (vii) problem 58 for this  $S$ .

(ii) Can  $S$  have subset idempotents?

(iii) Can  $S$  have  $S$ -subset idempotents?

67. Let  $S = \{\text{Collection of all subsets from the interval matrix semiring}$

$$M = \left\{ \left[ \begin{array}{c} [a_1, b_1] \\ [a_2, b_2] \\ [a_3, b_3] \\ [a_4, b_4] \\ [a_5, b_5] \\ [a_6, b_6] \\ [a_7, b_7] \\ [a_8, b_8] \\ [a_9, b_9] \end{array} \right] \mid a_i, b_i \in LA_4 \right.$$

where  $L$  is the lattice given in the following  $L =$

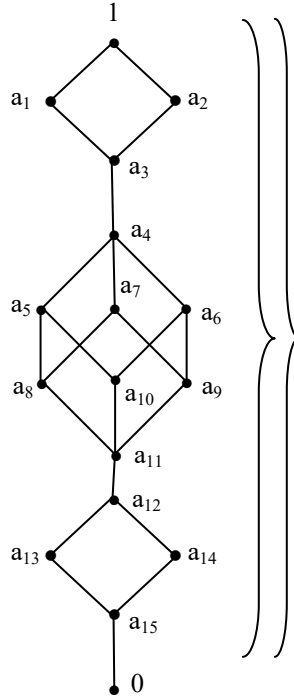

be the subset semiring.

- (i) Study questions (i) to (v) problem 65 for this S.
- (ii) Study questions (i) to (iii) problem 66 for this S.

68. Let  $S = \{\text{Collection of all subsets from the interval matrix}$

$$\text{semiring } M = \left\{ \begin{bmatrix} [a_1, b_1] & [a_2, b_2] & \dots & [a_{10}, b_{10}] \\ [a_{11}, b_{11}] & [a_{12}, b_{12}] & \dots & [a_{20}, b_{20}] \\ [a_{21}, b_{21}] & [a_{22}, b_{22}] & \dots & [a_{30}, b_{30}] \\ [a_{31}, b_{31}] & [a_{32}, b_{32}] & \dots & [a_{40}, b_{40}] \end{bmatrix} \right\} a_i, b_i$$

$\in L (D_{2,7} \times A_5): 1 \leq i \leq 40\}$  be the subset semiring, where L is as in problem 67.

- (i) Study questions (i) to (v) problem 65 for this S.
- (ii) Study questions (i) to (iii) problem 66 for this S.

69. Let  $S = \{\text{Collection of all subsets from the interval matrix}$

$$\text{semiring } P = \left\{ \begin{bmatrix} [a_1, b_1] & [a_2, b_2] & \dots & [a_6, b_6] \\ [a_{11}, b_{11}] & [a_{12}, b_{12}] & \dots & [a_{12}, b_{12}] \\ \vdots & \vdots & \dots & \vdots \\ [a_{31}, b_{31}] & [a_{32}, b_{32}] & \dots & [a_{36}, b_{36}] \end{bmatrix} \right\} a_i, b_i$$

$\in L_1 \times L_2 D_{2,13}$  where  $L_1 =$

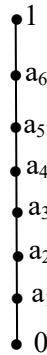

and  $L_2 = \{ 1 \leq i \leq 36 \}$

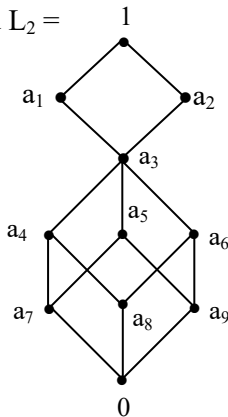

be the subset semiring.

- (i) Study questions (i) to (v) problem 65 for this S.
- (ii) Study questions (i) to (iii) problem 66 for this S.

70. Let  $S = \{\text{Collection of all subsets from the interval polynomial semiring}$

$$P = \left\{ \sum_{i=0}^{\infty} a_i x^i \mid a_i \in L \text{ where } L = \right.$$

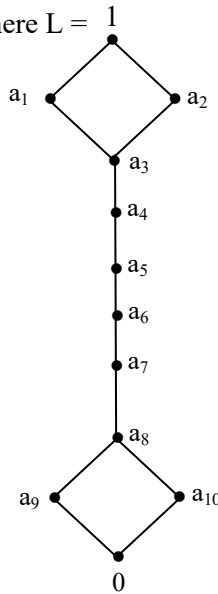

be the subset semiring of infinite order.

- (i) Study questions (i) to (v) problem 65 for this S.
- (ii) Study questions (i) to (iii) problem 66 for this S.

71. Let  $S = \{\text{Collection of all subsets from the interval polynomial semiring}$

$$M = \left\{ \sum_{i=0}^{\infty} [a_i, b_i] x^i \mid a_i, b_i \in LA_6 \text{ where } L = \right.$$



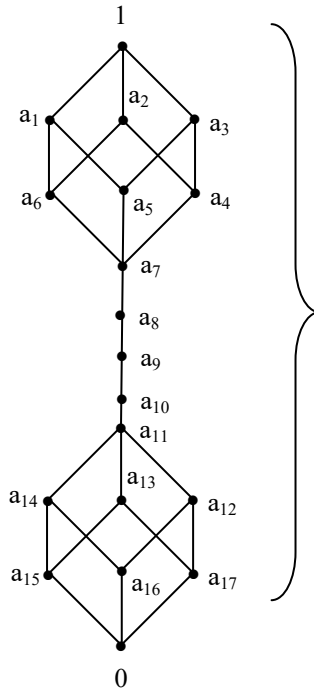

be the subset semiring infinite order.

- (i) Study questions (i) to (v) problem 65 for this S.
- (ii) Study questions (i) to (iii) problem 66 for this S.

72. Let  $S = \{\text{Collection of all subsets from the interval polynomial semiring } M = \left\{ \sum_{i=0}^{\infty} [a_i, b_i]x^i \mid a_i, b_i \in \langle Q \cup I \cup \{0\} \rangle\right\}$  be the subset semiring.

- (i) Show S has infinite number of subset interval polynomial subsemirings which are not ideals.
- (ii) Can S have subset ideal semirings?
- (iii) Prove S has pairs A, B of subsets semiring ideals (subsemirings) such that  $A \times B = \{[0, 0]\}$ .

- (iv) Prove  $T_S$ ,  $T_{\cup}^{\times}$  and  $T_{\cap}^{\times}$  have infinite collection of pairs of subspaces C and D with  $C \times D = \{[0, 0]\}$ .

73. Let  $S = \{\text{Collection of all subsets from the interval polynomial}$

$$P = \left\{ \sum_{i=0}^{\infty} [a_i, b_i] x^i \mid a_i, b_i \in \langle Z \cup I \cup \{0\} \rangle S_6 \right\}$$

be the subset semiring.

- (i) Prove S is non commutative.
- (ii) Find subset semiring right ideal in S which are not subset semiring left ideals of S.
- (iii) Find two sided ideals of S.
- (iv) Study questions (i) to (iv) problem 72 for this S.
- (v) Show the topological semiring spaces  $T_S$ ,  $T_{\cup}^{\times}$  and  $T_{\cap}^{\times}$  are all non commutative.
- (vi) Can the three spaces  $T_S$ ,  $T_{\cup}^{\times}$  and  $T_{\cap}^{\times}$  have commutative subspaces?

74. Let  $S = \{\text{Collection of all subsets from the interval polynomial semiring}$

$$M = \left\{ \sum_{i=0}^{\infty} [a_i, b_i] x^i \mid a_i, b_i \in \langle R \cup I \rangle (S_6 \times A_5) \right\}$$

be the subset semiring.

- (i) Study questions (i) to (vi) problem 73 for this S.

75. Let  $S = \{\text{Collection of all subsets from the interval polynomial semiring}\}$

$$M = \left\{ \sum_{i=0}^{\infty} [a_i, b_i] x^i \mid a_i, b_i \in \langle \mathbb{Q}^+ \cup I \rangle (S(5) \times D_{2,11}) \right\}$$

be the subset semiring.

- (i) Study questions (i) to (vi) problem 73 for this  $S$ .
76. Is it possible to have a subset interval non commutative semiring which has no subset interval non commutative subsemiring?
77. Is it possible to have a subset non commutative semiring which has no subset interval non commutative subsemiring?
78. Is it possible to have a subset semiring which has no subset subsemiring?
79. Is it possible to have a subset non commutative semiring which has all its subset subsemirings to be non commutative?
80. Develop some applications of the six topological spaces  $T_o, T_s, T_{\cup}^+, T_{\cup}^{\times}, T_{\cap}^+$  and  $T_{\cap}^{\times}$  of subset semirings.
81. Find some special and striking features enjoyed by subset semiring topological spaces  $T_o, T_s, T_{\cup}^+, T_{\cup}^{\times}, T_{\cap}^+$  and  $T_{\cap}^{\times}$ .
82. Can an infinite subset semiring have finite subset subsemirings?
83. Can one say if the semiring used is a Boolean algebra of order greater than two the subset semirings will have subset zero divisors?

84. Characterize those subset semirings which has S-subset zero divisors.
85. Characterize those subset semirings which has no subset idempotents.
86. Characterize those subset semirings in which every subset idempotents is a S-subset idempotent.
87. Characterize those subset semirings which has S-subset units.
88. Characterize those subset semirings which has no subset units.

## Chapter Four

# SUBSET SET IDEAL TOPOLOGICAL SEMIRING SPACES

In this chapter we for the first time study the set ideals of a subset semiring over a subset subsemiring as topological spaces. This study is innovative and interesting.

We proceed onto define this new notion and illustrate them with examples.

**DEFINITION 4.1:** *Let  $S = \{\text{Collection of all subsets from a ring } R \text{ (or semiring } P)\}$  be the subset semiring.*

*Let  $A \subseteq R$  (or  $A \subseteq P$ ) be a subring of  $R$  (or a subsemiring of  $P$ ).*

*Let  ${}_A T = \{\text{Collection of all subset set ideals of } S \text{ over the subring } A \text{ of } R \text{ (or over the subsemiring } A \text{ of } P)\}$ .*

*${}_A T$  can be given any of the six topologies  ${}_A T_o$ ,  ${}_A T_S$ ,  ${}_A T_\cup^+$ ,  ${}_A T_\cap^+$ ,  ${}_A T_\cup^\times$  and  ${}_A T_\cap^\times$  and these topologies will be known as subset set ideal semiring topological spaces of  $S$  over the*

*subring or the subsemiring over which the subset semiring S is built.*

We now proceed onto give examples of them.

**Example 4.1:** Let  $S = \{\text{Collection of all subsets from the ring } Z_6\}$  be the subset semiring. The subrings of  $Z_6$  are  $P_1 = \{0, 3\}$  and  $P_2 = \{0, 2, 4\}$ .

The collection of all subset set semiring ideals of  $P_1$  be denoted by  ${}_P T = \{\{0\}, \{0, 3\}, \{0, 2\}, \{0, 4\}, \{0, 2, 4\}, \{0, 2, 3\}, \{0, 3, 4\}, \{0, 3, 2, 4\}, \{0, 2, 3, 1\}, \{0, 2, 4, 3, 1\}, \{0, 3, 4, 1\}, \{0, 3, 1\}, \{0, 1, 5, 3\}, \{0, 5, 3\}, \{0, 5, 3, 2\}, \{0, 5, 4, 3\}$  and so on).

We have the six topological spaces  ${}_P T_o = \{{}_P T \cup \{\phi\}, \cup, \cap\}$ ,  ${}_P T_S = \{{}_P T, +, \times\}$ ,  ${}_P T_\cup^\times = \{{}_P T, \cup, \times\}$ ,  ${}_P T_\cup^+ = \{{}_P T, \cup, +\}$ ,  ${}_P T_\cap^\times = \{{}_P T \cup \{\phi\}, \cap, \times\}$ , and  ${}_P T_\cap^+ = \{{}_P T \cup \{\phi\}, \cap, +\}$  which are set ideal subset semiring topological spaces of S over the subring  $P_1$ .

Let  ${}_P T = \{\text{Collection of all subset set ideals of S over the subring } P_2 = \{0, 2, 4\}\} = \{\{0\}, \{3, 0\}, \{0, 2, 4\}, \{0, 2, 4, 3\}, \{0, 5, 4, 2\}, \{1, 0, 2, 4\}, \{0, 1, 2, 3, 4\}, \{0, 5, 2, 4, 3\}, \{0, 2, 4, 5, 3\}, \{0, 5, 1, 2, 4\}, \{0, 5, 1, 2, 3, 4\}\}$ .

Clearly  ${}_P T_o, {}_P T_S, {}_P T_\cup^\times, {}_P T_\cap^\times, {}_P T_\cup^+$  and  ${}_P T_\cap^+$  are the six subset set semiring ideal topological spaces of S over the subring  $P_2$ .

Thus we have only two sets of topological spaces.

Let  $A = \{0, 2, 4, 3\}$  and  $B = \{0, 1, 2, 5, 4\} \in {}_P T_o$ .

$$\begin{aligned} A \cup B &= \{0, 2, 4, 3\} \cup \{0, 1, 2, 5, 4\} \\ &= \{1, 2, 3, 4, 5, 0\} \end{aligned}$$

and

$$\begin{aligned} A \cap B &= \{0, 2, 4, 3\} \cap \{0, 1, 2, 5, 4\} \\ &= \{0, 2, 4\} \text{ are in } {}_{P_2}T_o. \end{aligned}$$

Now

$$\begin{aligned} A + B &= \{0, 2, 4, 3\} + \{0, 1, 2, 5, 4\} \\ &= \{0, 1, 3, 5, 4, 2\} \end{aligned}$$

and

$$\begin{aligned} A \times B &= \{0, 2, 4, 3\} \times \{0, 1, 2, 5, 4\} \\ &= \{0, 2, 4, 3\} \text{ are in } {}_{P_2}T_s. \end{aligned}$$

$$\begin{aligned} \text{Let } A &= \{0, 2, 4\} \text{ and } B = \{0, 3\} \\ A + B &= \{0, 2, 4, 3, 5, 1\}. \end{aligned}$$

This is the way operations are performed on  ${}_{P_2}T_o$ ,  ${}_{P_2}T_s$ ,  ${}_{P_2}T_o^\times$ ,  ${}_{P_2}T_s^\times$ ,  ${}_{P_2}T_o^+$  and  ${}_{P_2}T_s^+$ . Some of them are distinct and some of them are identical.

**Example 4.2:** Let

$S = \{\text{Collection of all subsets from the ring } Z\}$  be the subset semiring. Clearly  $P_1 = 2Z$  be a subring of  $Z$ .  ${}_{P_1}T = \{\text{Collection of all subset set ideal of } S \text{ over the subring } P_1\}$ ,  $\{\{0\}, 2Z, 3Z, 4Z, 6Z, 5Z, \dots, Z \text{ are all set ideals}\}$ .

It is easily verified spaces  ${}_{P_1}T_o$ ,  ${}_{P_1}T_s$ ,  ${}_{P_1}T_o^\times$ ,  ${}_{P_1}T_s^\times$ ,  ${}_{P_1}T_o^+$  and  ${}_{P_1}T_s^+$  are all subset set ideal semiring topological spaces which are distinct.

Infact  $Z$  has infinite number of subring so  $S$  has infinite number of subset set ideal semiring topological spaces of  $S$ .

**Example 4.3:** Let

$S = \{\text{Collection of all subsets from the ring } Z_{15}\}$  be the subset semiring of the ring  $Z_{15}$ .

The subrings of  $Z_{15}$  are  $P_1 = \{0, 5, 10\}$  and  $P_2 = \{0, 3, 6, 9, 12\}$ .  ${}_P T$  and  ${}_P T$  give way to subset set ideal semiring topological spaces of  $S$  over  $P_1$  and  $P_2$  respectively.

${}_P T = \{\{0\}, \{0, 5, 10\}, \{0, 2, 5, 10\}, \{0, 1, 5, 10\}, \{0, 4, 5, 10\}, \{0, 6, 5, 10\}, \{0, 8, 5, 10\}, \{0, 12, 5, 10\}, \{0, 14, 5, 10\}, \{0, 3, 5, 10\}, \{0, 9, 5, 10\}, \{0, 1, 2, 5, 10\}, \dots, \{0, 2, 1, 3, 4, 5, 6, \dots, 14\}\}$  be the collection of all subset semiring set ideal of  $S$  over the subring  $P_1 = \{0, 5, 10\}$ .

Let  $A = \{0, 2, 5, 10\}$  and  $B = \{0, 13, 5, 10\} \in {}_P T_o$ .

Now

$$\begin{aligned} A \cup B &= \{0, 2, 5, 10\} \cup \{0, 13, 5, 10\} \\ &= \{0, 5, 10, 13, 2\} \text{ and} \end{aligned}$$

$$\begin{aligned} A \cap B &= \{0, 2, 5, 10\} \cap \{0, 13, 5, 10\} \\ &= \{0, 5, 10\} \text{ are in } {}_P T_o. \end{aligned}$$

Consider  $A, B \in {}_P T_S$ .

$$\begin{aligned} A + B &= \{0, 2, 5, 10\} + \{0, 13, 5, 10\} \\ &= \{0, 13, 5, 10, 2, 8, 3, 7, 12\} \end{aligned}$$

$$\begin{aligned} \text{and } A \times B &= \{0, 2, 5, 10\} \times \{0, 13, 5, 10\} \\ &= \{0, 10, 5, 11\} \text{ are in } {}_P T_S. \end{aligned}$$

Clearly  ${}_P T_o$  is different from  ${}_P T_S$  as subset set ideal semiring topological spaces of  $S$  over the subring  $P_1$ .

Let  $A, B \in {}_P T_{\cup}^+$

$$\begin{aligned} A + B &= \{0, 10, 5, 2\} + \{0, 13, 5, 10\} \\ &= \{0, 2, 3, 5, 7, 8, 10, 12, 13\} \end{aligned}$$



and

$$\begin{aligned} A \cup B &= \{0, 10, 5, 2\} \cup \{0, 13, 5, 10\} \\ &= \{0, 10, 5, 13, 2\} \text{ are in } {}_P_1 T_{\cup}^+ . \end{aligned}$$

We see  ${}_P_1 T_{\cup}^+$  is different from  ${}_P_1 T_o$  and  ${}_P_1 T_S$  as subset set ideal semiring topological spaces of S over the subring  $P_1$  of  $Z_{15}$ .

Consider  $A, B \in {}_P_1 T_{\cup}^{\times}$

$$\begin{aligned} A \cup B &= \{0, 2, 5, 10\} \cup \{0, 5, 10, 13\} \\ &= \{0, 5, 10, 2, 13\} \end{aligned}$$

and

$$\begin{aligned} A \times B &= \{0, 2, 5, 10\} \times \{0, 5, 10, 13\} \\ &= \{0, 10, 5, 11\} \text{ are in } {}_P_1 T_{\cup}^{\times} . \end{aligned}$$

We have  ${}_P_1 T_{\cup}^{\times}$  is different from  ${}_P_1 T_o$ ,  ${}_P_1 T_S$  and  ${}_P_1 T_{\cup}^+$  as set subset semiring ideal topological spaces of S over the subring  $P_1$  of  $Z_{15}$ .

Let  $A, B \in {}_P_1 T_{\cap}^+$ .

$$\begin{aligned} A + B &= \{0, 5, 2, 10\} + \{0, 13, 5, 10\} \\ &= \{0, 2, 5, 3, 7, 8, 10, 12, 13\} \end{aligned}$$

and

$$\begin{aligned} A \cap B &= \{0, 5, 2, 10\} \cap \{0, 13, 5, 10\} \\ &= \{0, 5, 10\} \text{ are in } {}_P_1 T_{\cap}^+ . \end{aligned}$$

${}_P_1 T_{\cap}^+$  is different from  ${}_P_1 T_{\cup}^{\times}$ ,  ${}_P_1 T_o$ ,  ${}_P_1 T_S$  and  ${}_P_1 T_{\cup}^+$  as subset set ideal semiring topological spaces of S over the subring  $P_1 = \{0, 5, 10\}$  of  $Z_{15}$ .

Let  $A, B \in {}_{P_1}T_{\cap}^{\times}$ ,

$$\begin{aligned} A \times B &= \{0, 5, 2, 10\} \times \{0, 5, 13, 10\} \\ &= \{0, 5, 10, 11\} \end{aligned}$$

and

$$\begin{aligned} A \cap B &= \{0, 5, 2, 10\} \cap \{0, 5, 13, 10\} \\ &= \{0, 5, 10\} \text{ are in } {}_{P_1}T_{\cap}^{\times}. \end{aligned}$$

${}_{P_1}T_{\cap}^{\times}$  are different from  ${}_{P_1}T_{\cup}^{\times}$ ,  ${}_{P_1}T_o$ ,  ${}_{P_1}T_s$ ,  ${}_{P_1}T_{\cup}^+$  and  ${}_{P_1}T_{\cap}^+$ .

We see all the six subset set of S over  $P_1$  ideal semiring topological spaces are different.

**Example 4.4:** Let  $S = \{\text{Collection of all subsets of the ring } Z_{24}\}$  be the subset semiring. The subring of  $Z_{24}$  are  $\{0, 12\}$ ,  $\{0, 6, 12, 18\}$ ,  $\{0, 4, 8, 12, 16, 20\}$ ,  $\{0, 2, 4, 6, 8, \dots, 22\}$ ,  $\{0, 8, 16\}$ , and  $\{0, 3, 6, 9, 12, 15, 18, 21\}$ .

Thus using these 6 subrings we can have 36 subset set ideal semiring topological subspaces of S over subrings of  $Z_{24}$ .

**Example 4.5:** Let

$S = \{\text{Collection of all subsets from the ring } Z_7\}$  be the subset semiring.  $Z_7$  has no subrings. So S has no subset set ideal topological semiring spaces over the subrings.

We call such subset semirings as subset simple semirings.

**Example 4.6:** Let  $S = \{\text{Collection of all subsets from } Z_{23}\}$  be the subset semiring. S is a subset simple semiring.

**Example 4.7:** Let

$S = \{\text{Collection of all subsets from the semiring } Z_{79}\}$  be the subset semiring. S is a subset simple semiring.

**THEOREM 4.1:** *Let*

$S = \{\text{Collection of all subsets from the ring } Z_p; p \text{ a prime}\}$  be the subset semiring.  $S$  is a subset simple semiring.

Proof follows from the simple fact  $Z_p$  the prime field of characteristic  $p$  has subrings hence the claim.

**Example 4.8:** Let

$S = \{\text{Collection of all subsets from the ring } Z_5S_4\}$  be the subset semiring.  $S$  is not subset simple for  $S$  has subset subsemirings.

**Example 4.9:** Let  $S = \{\text{Collection of all subsets from the ring } Z_7(g_1, g_2) \text{ with } g_1^2 = 0, g_2^2 = g_2 g_1 g_2 = g_2 g_1 = 0\}$  be the subset semiring.  $S$  is not a subset simple semiring for  $Z_7(g_1, g_2)$  has subrings. Hence associated with  $S$  we have subset semiring set ideal topological spaces of all the six types.

**Example 4.10:** Let  $S = \{\text{Collection of all subsets from the ring } Z_4 = \{0, 1, 2, 3\}\}$  be the subset semiring. The only subring in  $Z_4$  is  $\{0, 2\} = P_1$ . The subset set ideals of  $S$  over  $P_1$ .

${}_P T = \{\{0\}, \{0, 2\}, \{0, 1, 2\}, \{0, 3, 2\}, \{0, 1, 3, 2\}\}$  is the collection of all subset set ideals of  $S$  over  $P_1$ .

${}_P T_o, {}_P T_s, {}_P T_\cup, {}_P T_\cap^x, {}_P T_\cup^+$  and  ${}_P T_\cap^+$  are subset ideals of  $S$  over  $P_1$ .

The trees associated with  ${}_P T$  is

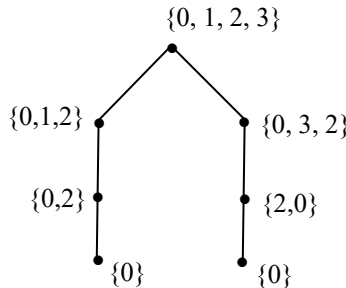

**Example 4.11:** Let

$S = \{\text{Collection of all subsets from the ring } Z_9\}$  be the subset semiring.

The only subring of  $Z_9$  is  $P_1 = \{0, 3, 9\}$ .

${}_1T = \{\text{Collection of all subset set ideals of } S \text{ over the ring } P_1\}$   
 $P_1 = \{0, 3, 6\} = \{\{0\}, \{0, 3, 6\}, \{0, 3\}, \{0, 6\}, \{0, 1, 3, 6\}, \{0, 2, 3, 6\}, \{0, 4, 3, 6\}, \{0, 5, 3, 6\}, \{0, 7, 3, 6\}, \{0, 8, 3, 6\}, \{0, 1, 3, 6, 2\}, \{0, 1, 3, 6, 4\}, \{0, 1, 3, 6, 5\}, \{0, 1, 3, 6, 7\}, \{0, 1, 3, 8, 6\}, \{0, 2, 4, 36\}, \{0, 2, 5, 36\}, \{0, 2, 7, 3, 6\}, \{0, 2, 8, 36\}, \{0, 4, 5, 3, 6\}, \{0, 4, 7, 3, 6\}, \{0, 4, 8, 3, 6\}, \{0, 5, 7, 3, 6\}, \{0, 5, 8, 36\}, \{0, 7, 8, 36\}, \{0, 1, 2, 4, 3, 6\}, \{0, 1, 2, 7, 3, 6\}, \{0, 1, 28, 36\}, \{0, 2, 4, 7, 3, 6\}, \{0, 1, 7, 8, 36\}, \{0, 1, 4, 8, 3, 6\}, \dots, \{0, 1, 2, 3, 4, 5, 6, 7\}\}$  be the subset set semiring ideals of  $S$  over  $P_1$ .

Interested reader can draw the associated tree of the spaces or in particular  ${}_1T$ .

**Example 4.12:** Let

$S = \{\text{Collection of all subsets from the ring } Z_8\}$  be the subset semiring. The subrings of  $Z_8$  are  $P_1 = \{0, 4\}$  and  $P_2 = \{0, 2, 4, 6\}$ .

The subsets ideals set semiring of  $S$  over  $P_1$  is  ${}_1T = \{\{0\}, \{0, 4\}, \{0, 2, 4\}, \{0, 3, 4\}, \{0, 2\}, \{0, 1, 4\}, \{0, 3, 4\}, \{0, 5, 4\}, \{0, 6\}, \{0, 2, 4\}, \{0, 6, 4\}, \{0, 7, 4\}, \dots\}$  be the collection of all subset semiring set ideals of  $S$  over the subring  $P_1$ .

Let  ${}_2T = \{\{0\}, \{0, 2, 4\}, \{0, 4\}, \{0, 6, 4\}, \{0, 2, 6, 4\}, \{0, 1, 6, 2, 4\}, \{0, 3, 2, 4, 6\}, \{0, 5, 2, 6, 4\}, \{0, 7, 2, 6, 4\}, \{0, 2, 4, 1, 3, 6\}, \{0, 2, 1, 6, 4, 5\}, \{0, 1, 2, 4, 6, 7\}, \{0, 3, 5, 2, 6, 4\}, \{0, 3, 7, 2, 6, 4\}, \{0, 5, 7, 2, 6, 4\}, \{0, 1, 3, 5, 2, 6, 4\}, \{0, 1, 5, 7, 2, 6, 4\}, \{0, 1, 3, 7, 2, 6, 4\}, \{0, 357, 264\}, \{0, 1, 2, 3, 4, 5, 6, 7\}\}$  be the collection of all subset semiring set ideals of  $S$  over  $P_2$ .

The tree associated with  $p_2 T$  is

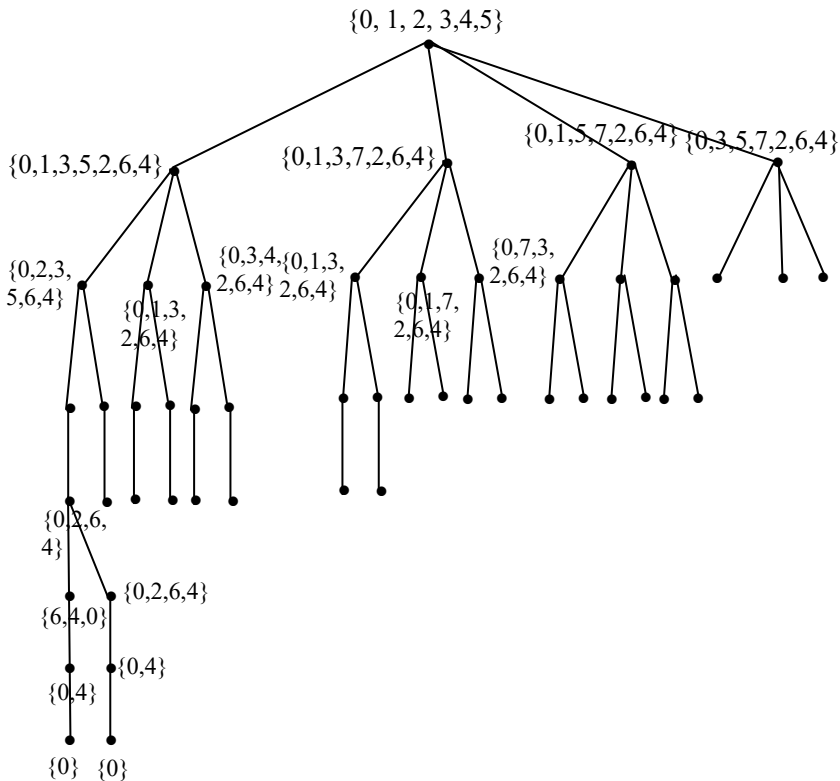

In view of all these examples we have the following theorem.

**THEOREM 4.2:** *Let*

*$S = \{\text{Collection of all subsets from the ring } Z_n\}$  be the subset semiring. If  $Z_n$  has  $t$  subrings associated with  $S$  we have  $6t$  number of subset set ideal topological spaces of  $S$  may be distinct or identical.*

The proof is direct and hence left as an exercise to the reader.

**Example 4.13:** Let

$S = \{\text{Collection of all subsets from ring } Z_{30}\}$  be the subset semiring. The subrings of  $S$  are  $P_1 = \{0, 15\}$ ,  $P_2 = \{0, 10, 20\}$ ,  $P_3 = \{0, 5, 10, 15, 20, 25\}$ ,  $P_4 = \{0, 3, 6, 9, \dots, 27\}$ ,  $P_5 = \{0, 2, 4, 6, \dots, 28\}$  and  $P_6 = \{0, 6, 12, 18, 24\}$  are the subring of  $Z_{30}$ . Associated with these six subrings we have 36 subset set ideal semiring topological spaces of the subrings  $P_1, P_2, \dots, P_6$ .

**Example 4.14:** Let

$S = \{\text{Collection of all subsets from the ring } Z_{45}\}$  be the subset semiring.  $S$  has atleast 24 subset set ideal semiring topological spaces of  $S$  over the subrings of  $Z_{45}$ .

**Example 4.15:** Let

$S = \{\text{Collection of all subsets from the ring } Z\}$  be the subset semiring.  $S$  has infinite number of subset set ideal semiring topological spaces of  $S$  associated with subrings of  $Z$ .

If in the example 4.15;  $Z$  is replaced by  $R$  or  $Z(g)$  or  $\langle Z \cup I \rangle$  or  $Q$  or  $\langle Q \cup I \rangle$  or  $C$  or  $\langle R \cup I \rangle$  or  $\langle C \cup I \rangle$  or  $C(g)$  etc  $S$  it / we get infinite number of subset set ideal semiring topological spaces of  $S$ . All these subset semirings and their related subset set ideal semiring topological spaces of  $S$  over subrings are also commutative.

**Example 4.16:** Let

$S = \{\text{Collection of all subsets from the group ring } Z_7S_4\}$  be the subset semiring. This has subset set ideal semiring topological spaces  ${}_P T_{\cup}^{\times}$ ,  ${}_P T_{\cap}^{\times}$ , and  ${}_P T_S$  to be non commutative over any subring  $P_i$  of  $Z_7S_4$  and all spaces have only finite number of elements in them.

**Example 4.17:** Let

$S = \{\text{Collection of all subsets from the ring } Z_4A_4\}$  be the subset semiring.

$S$  is non commutative so  $S$  has subset set ideal semiring topological spaces over subrings which are non commutative. Clearly  $o(S) < \infty$ .

**Example 4.18:** Let

$S = \{\text{Collection of all subsets from the ring } Z_3D_{2,9}\}$  be the subset semiring. We have subset set ideal topological semiring spaces over subrings which are commutative and some are also non commutative.

**Example 4.19:** Let

$S = \{\text{Collection of all subsets from the ring } R = (Z_6 \times Z_9) (D_{2,7})\}$  be the subset semiring.  $S$  has subset set ideal topological semiring subspaces of  $S$  over subrings of  $R$ . We see  $S$  has subset set ideal topological semiring zero divisors.

**Example 4.20:** Let

$S = \{\text{Collection of all subsets from the ring } R = (Z_9 \times Z_{12} \times Z_{30}) (D_{2,5} \times S_4)\}$  be the subset semiring.  $S$  has subset set ideal semiring topological spaces relative to subrings.  $S$  has subset set ideal semiring topological subspaces in  ${}_P T_{\cup}^{\times}$ ,  ${}_P T_{\cap}^{\times}$ , and  ${}_P T_S$  which are orthogonal or annihilates each other and some of them are non commutative.

**Example 4.21:** Let

$S = \{\text{Collection of all subsets of the ring } ZS_7\}$  be the subset semiring.  $S$  has subset set ideal semiring topological spaces over subring such that  ${}_P T_{\cup}^{\times}$ ,  ${}_P T_{\cap}^{\times}$  and  ${}_P T_S$  are non commutative.

**Example 4.22:** Let

$S = \{\text{Collection of all subsets from the ring } (Z \times Z) (S_3 \times D_{2,5})\}$  be the subset semiring.  $S$  has infinite number of subset set ideal semiring topological spaces which are non commutative and of infinite order.

**Example 4.23:** Let

$S = \{\text{Collection of all subsets from the ring } R = \langle Q \cup I \rangle S_5\}$  be the subset semiring.  $S$  has infinite number of subset set ideal topological semiring spaces of  $S$  over subrings of the ring  $R$ .

**Example 4.24:** Let  $S = \{\text{Collection of all subsets from the ring } R = ((C \cup I) (S_7 \times D_{2,5}))\}$  be the subset semiring.

$S$  has subset set ideal semiring topological spaces over the subrings  $P_i$  on  $R$ . All of them are of infinite order.

**Example 4.25:** Let  $S = \{\text{Collection of all subsets from the ring } P = \{R \times R \times R \times R\} S(5)\}$  be the subset semiring.

$S$  has subset set ideal semiring topological spaces over subrings of  $P$ . All of them are of infinite order.

**Example 4.26:** Let  $S = \{\text{Collection of all subsets from the matrix ring } M = \{(a_1, a_2, a_3, a_4, a_5, a_6) \mid a_i \in Z_6, 1 \leq i \leq 6\}\}$  be the subset semiring.

$S$  has subset set ideal semiring topological spaces over the subrings  $P_1 = \{0, 3\}$  (or  $P_2 = \{0, 2, 4\}$ ).

We see  ${}_P T_{\cup}^{\times}$ ,  ${}_P T_{\cap}^{\times}$  and  ${}_P T_S$  have pairs of subset set ideal semiring topological subspace such that their product is  $\{(0 \ 0 \ 0 \ 0 \ 0 \ 0)\}$ .

**Example 4.27:** Let  $S = \{\text{Collection of all subsets from the ring}$

$$M = \left\{ \begin{bmatrix} a_1 \\ a_2 \\ \vdots \\ a_{12} \end{bmatrix} \mid a_i \in Z_{12}, 1 \leq i \leq 12 \right\}$$

be the subset semiring.  $S$  has subset set ideal semiring topological spaces over any subring of  $Z_{12}$ .

Clearly the subset set ideal topological semirings over subrings of  $Z_{12}$  has pairs of subspaces such that



$$A \times B = \left\{ \begin{bmatrix} 0 \\ 0 \\ 0 \\ \vdots \\ 0 \end{bmatrix} \right\}.$$

**Example 4.28:** Let  $S = \{\text{Collection of all subsets from the matrix ring}\}$

$$M = \left\{ \begin{bmatrix} a_1 & a_2 & \dots & a_{10} \\ a_{11} & a_{12} & \dots & a_{20} \\ a_{21} & a_{22} & \dots & a_{30} \\ a_{31} & a_{32} & \dots & a_{40} \end{bmatrix} \mid a_i \in Z_{12} \times Z_{18}, 1 \leq i \leq 40 \right\}$$

be the subset semiring.  $S$  has subset set ideal semiring topological spaces over subrings of the ring  $\{Z_{12} \times Z_{18}\}$ . Clearly every subset set ideal semiring topological spaces  ${}_{P_i}T_{\cup}^{\times}$ ,  ${}_{P_i}T_{\cup}^{\times}$  and  ${}_{P_i}T_S$  have pairs of subset set ideal semiring topological subspaces  $A$  and  $B$  and

$$A \times B = \left\{ \begin{bmatrix} 0 & 0 & \dots & 0 \\ 0 & 0 & \dots & 0 \\ 0 & 0 & \dots & 0 \\ 0 & 0 & \dots & 0 \end{bmatrix} \right\}.$$

**Example 4.29:** Let  $S = \{\text{Collection of all subsets from the matrix ring}\}$

$$M = \left\{ \begin{bmatrix} a_1 & a_2 & a_3 & a_4 \\ a_5 & a_6 & a_7 & a_8 \\ a_9 & a_{10} & a_{11} & a_{12} \\ a_{13} & a_{14} & a_{15} & a_{16} \end{bmatrix} \mid a_i \in Z_{48}, 1 \leq i \leq 16 \right\}$$

be the subset semiring. Clearly  $S$  has subset semiring topological pairs of subspaces of  ${}_P T_{\cap}^{\times}$ ,  ${}_P T_{\cup}^{\times}$  and  ${}_P T_S$  such that

$$A \times B = \left\{ \begin{bmatrix} 0 & 0 & 0 & 0 \\ 0 & 0 & 0 & 0 \\ 0 & 0 & 0 & 0 \\ 0 & 0 & 0 & 0 \end{bmatrix} \right\}.$$

**Example 4.30:** Let  $S = \{\text{Collection of all subsets from the matrix ring } P = (a_1, a_2, a_3, \dots, a_7) \mid a_i \in Z_6 S_7; 1 \leq i \leq 7\}$  be the subset semiring.  $S$  has subset set ideal semiring topological spaces over the subrings.  ${}_P T_S$ ,  ${}_P T_{\cup}^{\times}$  and  ${}_P T_{\cap}^{\times}$  are subset set ideal semiring topological spaces of  $S$  over the  $P_i$  which are non commutative.

Infact  ${}_P T_{\cup}^{\times}$ ,  ${}_P T_{\cap}^{\times}$  and  ${}_P T_S$  have pairs of subspaces  $A, B$  such that  $A \times B = \{(0 \ 0 \ 0 \ 0 \ 0 \ 0 \ 0)\}$

**Example 4.31:** Let  $S = \{\text{Collection of all subsets from the matrix ring}$

$$M = \left\{ \begin{bmatrix} a_1 & a_2 \\ a_3 & a_4 \\ \vdots & \vdots \\ a_{13} & a_{14} \end{bmatrix} \mid a_i \in Z_5 (D_{2,7} \times S(4)), 1 \leq i \leq 14 \right\}$$

be the subset semiring.  $S$  has several subset semiring set ideal topological space  ${}_P T_{\cup}^{\times}$ ,  ${}_P T_{\cap}^{\times}$  and  ${}_P T_S$  which are non commutative and they have commutative subset set semiring ideal topological subspaces as well as non commutative subset set semiring ideal topological subspaces.

**Example 4.32:** Let  $S = \{\text{Collection of all subsets from the matrix ring}$

$$M = \left\{ \begin{bmatrix} a_1 & a_2 & a_3 & a_4 \\ a_5 & a_6 & a_7 & a_8 \\ a_9 & a_{10} & a_{11} & a_{12} \\ a_{13} & a_{14} & a_{15} & a_{16} \end{bmatrix} \mid a_i \in Z(S_3 \times D_{2,7}); 1 \leq i \leq 16 \right\}$$

be the subset semiring.  $S$  have several subset set ideal semiring topological spaces over the subring  $P_i$ .  ${}_i T_{\cup}^{\times}$ ,  ${}_i T_{\cap}^{\times}$  and  ${}_i T_S$  are commutative.  ${}_i T_{\cup}^{\times}$ ,  ${}_i T_{\cap}^{\times}$  and  ${}_i T_S$  have subset set ideal topological subspace pairs  $A, B$  such that

$$A \times B = \left\{ \begin{bmatrix} 0 & 0 & 0 & 0 \\ 0 & 0 & 0 & 0 \\ 0 & 0 & 0 & 0 \\ 0 & 0 & 0 & 0 \end{bmatrix} \right\}.$$

Now in view of these examples we formulate the following theorem.

**THEOREM 4.3:** *Let  $S = \{ \text{Collection of all subsets from the matrix ring } P \text{ with entries from } R \}$  be the subset semiring.  ${}_i T_o$ ,  ${}_i T_{\cup}^{\times}$ ,  ${}_i T_{\cup}^{+}$ ,  ${}_i T_{\cap}^{\times}$ ,  ${}_i T_{\cap}^{+}$  and  ${}_i T_S$  are subset set ideal semiring topological spaces of  $S$  over the subring  $P_i$  of the ring  $R$  over which it is defined.  ${}_i T_{\cup}^{\times}$ ,  ${}_i T_{\cap}^{\times}$  and  ${}_i T_S$  have pairs of set ideals subset semiring topological subspaces  $A, B$  with  $A \times B = \{(0)\}$ .*

Proof follows from the simple fact that we have matrices such that the product is zero.

**Example 4.33:** Let  $S = \{ \text{Collection of all subsets from the interval ring } P = \{([a_1, b_1], [a_2, b_2], \dots, [a_7, b_7]) \mid a_i, b_i \in Z_{10}; 1 \leq i \leq 7\} \}$  be the subset semiring.  ${}_i T_{\cup}^{\times}$ ,  ${}_i T_{\cup}^{+}$ ,  ${}_i T_{\cap}^{\times}$ ,  ${}_i T_{\cap}^{+}$ ,  ${}_i T_o$  and  ${}_i T_S$  be the subset set ideal interval semiring topological spaces over the subring  $P_i \subseteq Z_{10}$ .

$P_1 T_{\cup}^{\times}$ ,  $P_1 T_{\cap}^{\times}$  and  $P_1 T_S$  have pairs of subset set ideal interval semiring topological subspaces  $A, B$  such that  $A \times B = \{([0, 0], [0, 0], \dots, [0, 0])\}$ .

**Example 4.34:** Let  $S = \{\text{Collection of all subsets from the interval matrix ring}$

$$M = \left\{ \left[ \begin{array}{c} [a_1 b_1] \\ [a_2 b_2] \\ \vdots \\ [a_{10} b_{10}] \end{array} \right] \mid a_i, b_i \in Z_4 \times Z_6; 1 \leq i \leq 10 \right\}$$

be the subset semiring.

$P_1 = Z_4 \times \{0\}$ ,  $P_2 = \{0\} \times Z_6$ ,  $P_3 = \{0, 2\} \times Z_6$ ,  $P_4 = \{0, 2\} \times \{0\}$ ,  $P_5 = \{0, 2\} \times \{0, 3\}$ ,  $P_6 = \{0, 2\} \times \{0, 2, 4\}$ ,  $P_7 = \{0\} \times \{0,3\}$  and  $P_8 = \{0\} \times \{0, 2, 4\}$  be subrings using which the interval matrix subrings can be built. We see the three subset set ideal semiring topological spaces  $T_{\cup}^{\times}$ ,  $T_{\cap}^{\times}$  and  $T_S$  have pairs of subspaces  $A, B$  which are orthogonal that is

$$A \times B = \left\{ \left[ \begin{array}{c} [0,0] \\ [0,0] \\ \vdots \\ [0,0] \end{array} \right] \right\}.$$

**Example 4.35:** Let  $S = \{\text{Collection of all subsets from the interval matrix ring}$

$$M = \left\{ \left[ \begin{array}{cccc} [a_1 b_1] & [a_2 b_2] & \dots & [a_6 b_6] \\ [a_7 b_7] & [a_8 b_8] & \dots & [a_{12} b_{12}] \\ \vdots & \vdots & & \vdots \\ [a_{31} b_{31}] & [a_{32} b_{32}] & \dots & [a_{36} b_{36}] \end{array} \right] \mid a_i, b_i \in Z_{12} \times Z_{15}; \right. \\ \left. 1 \leq i \leq 36 \right\}$$

be the subset interval semiring.

$P_1 = \{\text{Collection of all } 6 \times 6 \text{ interval matrices with entries from the subring } \{0, 6\} \times \{0, 5, 10\} \subseteq Z_{12} \times Z_{15}\}$  be interval subring.  ${}_{P_1}T_{\cup}^{\times}$ ,  ${}_{P_1}T_{\cap}^{\times}$  and  ${}_{P_1}T_S$  are subset set ideal semiring interval topological spaces of S.

We have pairs of subspaces A, B in  ${}_{P_1}T_{\cup}^{\times}$ ,  ${}_{P_1}T_{\cap}^{\times}$  and  ${}_{P_1}T_S$  with  $A \times B = \{(0)\}$ .

**Example 4.36:** Let  $S = \{\text{Collection of all subset from the ring}$

$$M = \left\{ \begin{bmatrix} [a_1 b_1] & [a_2 b_2] & [a_3 b_3] & \dots & [a_9 b_9] \\ [a_{10} b_{10}] & [a_{11} b_{11}] & [a_{12} b_{12}] & \dots & [a_{18} b_{18}] \\ [a_{19} b_{19}] & [a_{20} b_{20}] & [a_{21} b_{21}] & \dots & [a_{27} b_{27}] \\ [a_{28} b_{28}] & [a_{29} b_{29}] & [a_{30} b_{30}] & \dots & [a_{36} b_{36}] \\ [a_{37} b_{37}] & [a_{38} b_{38}] & [a_{39} b_{39}] & \dots & [a_{45} b_{45}] \end{bmatrix} \mid a_i, b_i \in Z_{45}S_6; 1 \leq i \leq 45 \right\}$$

be the subset interval non commutative semiring.

${}_{P_1}T_S$ ,  ${}_{P_1}T_{\cap}^{\times}$  and  ${}_{P_1}T_{\cup}^{\times}$  are subset set ideal semiring interval topological spaces which has subspaces both commutative and non commutative and has pairs of subspaces A, B with

$$A \times B = \left\{ \begin{bmatrix} [0,0] & \dots & [0,0] \\ \vdots & & \vdots \\ [0,0] & \dots & [0,0] \end{bmatrix} \right\}.$$

**Example 4.37:** Let  $S = \{\text{Collection of all subsets from the super matrix ring } M = \{(a_1 \ a_2 \mid a_3 \ a_4 \ a_5 \mid a_6 \ a_7 \ a_8 \ a_9) \mid a_i \in Z_{40}; 1 \leq i \leq 8\}\}$  be the subset super matrix semiring.

M is commutative so all the six set ideal subset semiring topological spaces of S over subring of M are commutative.

**Example 4.38:** Let  $S = \{\text{Collection of all subsets from the super matrix ring } P = \{(a_1 | a_2 a_3 a_4 | a_5 a_6 | a_7 a_8 a_9 | a_{10}) \mid a_i \in Z_{12} (S_3 \times D_{2,7}); 1 \leq i \leq 10\}\}$  be the subset super matrix semiring of P. Clearly the set ideal subset semiring topological spaces  ${}_{P_i} T_S$ ,  ${}_{P_i} T_{\cap}^{\times}$  and  ${}_{P_i} T_{\cup}^{\times}$  are non commutative over the subring  $P_i$  of P.

**Example 4.39:** Let  $S = \{\text{Collection of all subsets from the super matrix ring}$

$$B = \left\{ \left[ \begin{array}{c} a_1 \\ a_2 \\ a_3 \\ a_4 \\ a_5 \\ a_6 \\ a_7 \\ a_8 \end{array} \right] \mid a_i \in Z; 1 \leq i \leq 8 \right\}$$

be the subset semiring. All subset set ideal semiring topological spaces of S over subrings of Z are of infinite order and are commutative.

**Example 4.40:** Let  $S = \{\text{Collection of all subsets from the super matrix ring}$

$$B = \left\{ \left[ \begin{array}{c} a_1 \\ a_2 \\ a_3 \\ a_4 \\ a_5 \\ a_6 \\ a_7 \\ a_8 \\ a_9 \end{array} \right] \mid a_i \in \langle Z \cup I \rangle; 1 \leq i \leq 9 \right\}$$

be the subset semiring.

Clearly the subset semiring set ideal topological spaces of S over the subrings  $P_i$  of  $\langle Z \cup I \rangle S_7$ ,  ${}_{P_i}T_{\cup}^{\times}$ ,  ${}_{P_i}T_{\cap}^{\times}$  and  ${}_{P_i}T_S$  are non commutative and are of infinite order.

**Example 4.41:** Let  $S = \{\text{Collection of all subsets from the super matrix ring}$

$$B = \left\{ \left[ \begin{array}{c|cccc|cc} a_1 & a_2 & a_3 & a_4 & a_5 & a_6 & a_7 \\ a_8 & a_9 & a_{10} & a_{11} & a_{12} & a_{13} & a_{14} \\ \hline a_{15} & \dots & \dots & \dots & \dots & \dots & a_{21} \\ a_{22} & \dots & \dots & \dots & \dots & \dots & a_{28} \\ a_{29} & \dots & \dots & \dots & \dots & \dots & a_{35} \\ \hline a_{36} & \dots & \dots & \dots & \dots & \dots & a_{42} \\ \hline a_{43} & \dots & \dots & \dots & \dots & \dots & a_{49} \end{array} \right] \mid a_i \in Z_{16}; 1 \leq i \leq 49 \} \right\}$$

be the subset semiring. S has subset set ideal semiring topological spaces (all of which are commutative) over subrings of  $Z_{16}$ .

**Example 4.42:** Let  $S = \{\text{Collection of all subsets from the super matrix ring}$

$$B = \left\{ \left[ \begin{array}{c|c|cc} a_1 & a_2 & a_3 & a_4 \\ a_5 & a_6 & a_7 & a_8 \\ a_9 & a_{10} & a_{11} & a_{12} \\ \hline a_{13} & a_{14} & a_{15} & a_{16} \end{array} \right] \mid a_i \in Z_{12}(S_3 \times D_{2,7}); 1 \leq i \leq 16 \} \right\}$$

be the subset semiring set ideal semiring topological spaces over subrings of  $Z_{12}(S_3 \times D_{2,7})$  of which  ${}_{P_i}T_S$ ,  ${}_{P_i}T_{\cup}^{\times}$  and  ${}_{P_i}T_{\cap}^{\times}$  are non commutative.

**Example 4.43:** Let  $S = \{\text{Collection of all subsets from the super matrix ring}$

$$B = \left\{ \left[ \begin{array}{c|cc|cc|c} a_1 & a_2 & a_3 & a_4 & a_5 & a_6 & a_7 & a_8 \\ a_9 & a_{10} & \dots & \dots & \dots & \dots & \dots & a_{16} \\ a_{17} & a_{18} & \dots & \dots & \dots & \dots & \dots & a_{24} \end{array} \right] \mid a_i \in \langle Z \cup I \rangle S_7, \right. \\ \left. 1 \leq i \leq 24 \right\}$$

be the subset super matrix semiring.  $S$  has the three subset set ideal semiring topological spaces,  ${}_P T_S$ ,  ${}_P T_{\cup}^{\times}$  and  ${}_P T_{\cap}^{\times}$  to be non commutative but of infinite order over any subring of  $\langle Z \cup I \rangle S_7$ .

**Example 4.44:** Let  $S = \{\text{Collection of all subsets from the interval super matrix ring } B = \{([a_1 \ b_1] \mid [a_2 \ b_2] \ [a_3 \ b_3] \ [a_4 \ b_4] \mid [a_5 \ b_5]) \mid a_i, b_i \in (Z_{13} \times Z_{16} \times Z_{45}) S_7; 1 \leq i \leq 5\}$  be the subset semiring.  $S$  has  ${}_P T_S$ ,  ${}_P T_{\cup}^{\times}$  and  ${}_P T_{\cap}^{\times}$ , to the subset set ideal semiring topological spaces over the subring  $P_i$  of  $(Z_{13} \times Z_{16} \times Z_{45}) S_7$  which are non commutative and of finite order.

**Example 4.45:** Let  $S = \{\text{Collection of all subsets from the interval super matrix ring}$

$$B = \left\{ \left[ \begin{array}{c|cc|cc|c} a_1 & a_2 & a_3 & a_4 & a_5 \\ a_6 & \dots & \dots & \dots & a_{10} \\ a_{11} & \dots & \dots & \dots & a_{15} \\ \hline a_{16} & \dots & \dots & \dots & a_{20} \\ a_{21} & \dots & \dots & \dots & a_{25} \\ \hline a_{26} & \dots & \dots & \dots & a_{30} \\ a_{31} & \dots & \dots & \dots & a_{35} \\ \hline a_{36} & \dots & \dots & \dots & a_{40} \end{array} \right] \mid a_i \in Z_{10} (S_3 \times D_{2,11}); \right. \\ \left. 1 \leq i \leq 40 \right\}$$



be the subset semiring.  $o(S) < \infty$  and all the three subset set ideal semiring topological spaces  ${}_P T_S$ ,  ${}_P T_U^\times$  and  ${}_P T_\cap^\times$ , are non commutative over the subring  $P_i$  of  $Z_{10} (S_3 \times D_{2,11})$ .

Now we proceed onto give examples of polynomial subset semiring and interval polynomial subset semirings.

**Example 4.46:** Let

$S = \{\text{Collection of all subsets from the polynomial ring } Z_5[x]\}$  be the subset semiring.  $S$  has infinite number or subset set ideal semiring topological spaces over subrings of  $Z_5[x]$ .

**Example 4.47:** Let

$S = \{\text{Collection of all subsets from the ring } Z[x]\}$  be the subset semiring.  $S$  has infinite number of subset set ideal semiring topological spaces over subrings of  $Z[x]$  all of which are all commutative.

**Example 4.48:** Let  $S = \{\text{Collection of all subsets from the ring } R[x] \text{ where } R = Z_{12} D_{2,7}\}$  be the subset semiring.  $S$  has infinite number of subset set ideal semiring topological spaces of which  ${}_P T_S$ ,  ${}_P T_U^\times$  and  ${}_P T_\cap^\times$  are non commutative.

**Example 4.49:** Let  $S = \{\text{Collection of all subsets from the non commutative polynomial ring } R[x] \text{ where } R = \langle Q \cup I \rangle S_5\}$  be the subset semiring.  $S$  has infinite number of subset set ideal semiring topological spaces of which  ${}_P T_S$ ,  ${}_P T_U^\times$  and  ${}_P T_\cap^\times$  are all non commutative and of infinite order.

Now we proceed onto study subset semirings using semirings.

We will illustrate this situation by examples.

**Example 4.50:** Let

$S = \{\text{Collection of all subsets from the semiring } Z^+ \cup \{0\}\}$  be the subset semiring of type II.  $S$  has infinite number of subset

set ideal semiring topological spaces over the subsemirings  $P_i$  of  $Z^+ \cup \{0\}$ .

We have  $nZ^+ \cup \{0\}$ ;  $n \in \mathbb{N}$ ,  $n \neq 1$ , contribute to subsemirings of  $Z^+ \cup \{0\}$ . All these 6 spaces are of infinite cardinality and are commutative.

**Example 4.51:** Let  $S = \{\text{Collection of all subsets from the semiring } \langle Z^+ \cup I \rangle \cup \{0\}\}$  be the subset semiring.  $S$  has infinite number of subset set ideal semiring topological spaces over subsemirings and all of them are commutative as  $S$  is commutative.

**Example 4.52:** Let  $S = \{\text{Collection of all subsets from the semiring } B = (R^+ \cup \{0\}) (g_1 g_2); g_1^2 = 0, g_2^2 = g_2 \text{ with } g_1 g_2 = g_2 g_1 = 0\}$  be the subset semiring.  $S$  has infinite number of subset set ideal semiring topological spaces over subsemirings of  $S$ .

Infact the semiring  $B$  has infinite number of subsemirings.

**Example 4.53:** Let  $S = \{\text{Collection of all subsets from the semiring } B = (Z^+ \cup \{0\})S_3\}$  be the subset semiring.  $S$  has infinite number of subset set ideal semiring topological spaces over subsemiring  $P_i$  of  $B$  all are of infinite order and  ${}_i T_{\cup}^{\times}, {}_i T_{\cap}^{\times}$  and  ${}_i T_S$  are non commutative as topological spaces.

**Example 4.54:** Let  $S = \{\text{Collection of all subsets from the semiring } (\langle R^+ \cup I \rangle \cup \{0\}) \times (D_{2,7} \times S(4))\}$  be the subset semiring.

All subset set ideal semiring topological spaces over subsemiring  $P_i$  are of infinite order and  ${}_i T_{\cup}^{\times}, {}_i T_{\cap}^{\times}$  and  ${}_i T_S$  are non commutative over the subsemiring  $P_i$  of  $(\langle R^+ \cup I \rangle \cup \{0\}) (D_{2,7} \times S(4))$ .

**Example 4.55:** Let  $S = \{\text{Collection of all subsets from the semiring}\}$

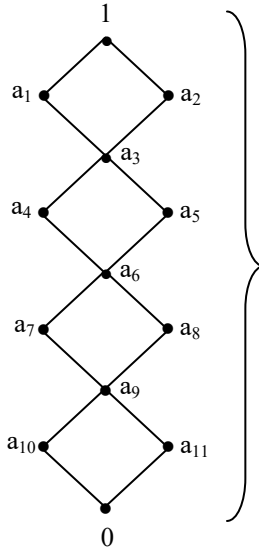

be the subset semiring.

$S$  has only a finite number of subset set ideal semiring topological spaces over the subsemiring  $P_i$  in  $B$ .

**Example 4.56:** Let  $S = \{\text{Collection of all subsets from the semiring } B =$

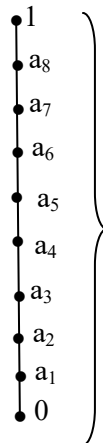

be the subset semiring,  $o(S) < \infty$ .  $S$  has only finite number of subset set ideal semiring topological spaces over subsemirings of  $B$ .

**Example 4.57:** Let  $S = \{\text{Collection of all subsets from the semiring } L =$

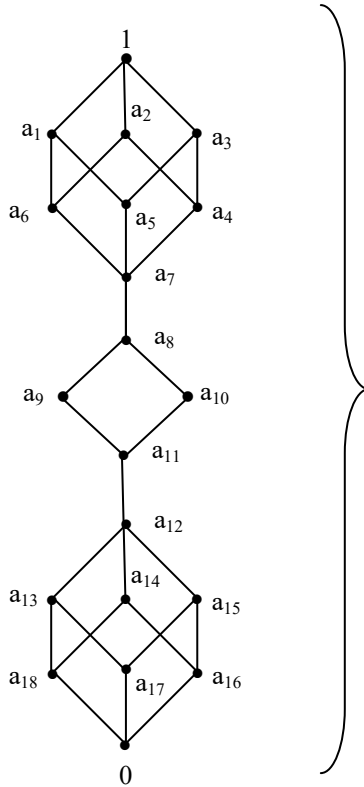

be the subset semiring.

$o(S) < \infty$ . All the six subset set ideal semiring topological spaces over the subsemirings of  $L$  are of finite order and are commutative.

**Example 4.58:** Let  $S = \{\text{Collection of all subsets from the semiring } BS_4 \text{ where } B =$

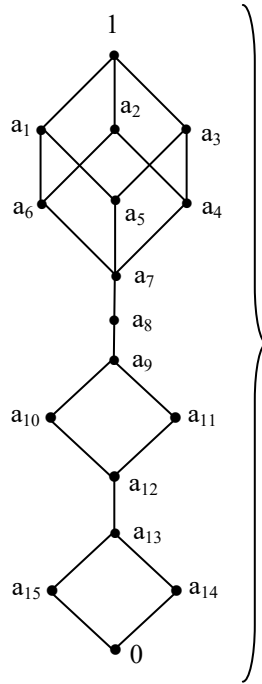

subset semiring.

$o(S) < \infty$  but  $S$  is non commutative.

${}_{P_i} T_S, {}_{P_i} T_{\cup}^{\times}$  and  ${}_{P_i} T_{\cap}^{\times}$  are subset set ideal semiring topological spaces over subsemirings  $P_i$  of  $S$  are non commutative and all of them are of finite order.

**Example 4.59:** Let  $S = \{\text{Collection of all subsets from the lattice group (group semiring) } BD_{2,7} \text{ where } B \text{ is a Boolean algebra of order } 2^7\}$  be the subset semiring;  $o(S) < \infty$ .

All the six set subset ideal semiring topological spaces are of finite order over the subsemirings  $P_i$  of  $BD_{2,7}$  and  ${}_{P_i} T_S, {}_{P_i} T_{\cup}^{\times}$  and  ${}_{P_i} T_{\cap}^{\times}$  are non commutative over  $P_i$ .

**Example 4.60:** Let  $S = \{\text{Collection of all subsets from the semiring } B(S_3 \times D_{2,5}) \text{ where } B =$

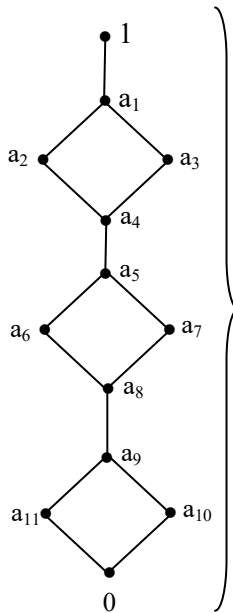

be the subset semiring.

$$o(S) < \infty.$$

$S$  is non commutative and has subset set ideal semiring topological spaces over subsemirings and are of finite order.

**Example 4.61:** Let  $S = \{\text{Collection of all subsets from the matrix semiring } M = \{(a_1, a_2, a_3, a_4, a_5) \mid a_i \in L =$

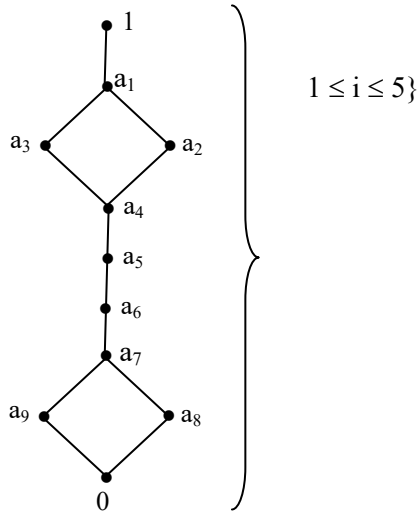

be the subset semiring of finite order.

The subset set ideal semiring topological space over the subsemiring  $P_i$  of  $M$  is of finite order.

Further the topological spaces  ${}_{P_i}T_S, {}_{P_i}T_{\cup}^{\times}$  and  ${}_{P_i}T_{\cap}^{\times}$  have pairs of subspaces  $A, B$  such that  $A \times B = \{(0\ 0\ 0\ 0\ 0)\}$ .

**Example 4.62:** Let  $S = \{\text{Collection of all subsets from the semiring}\}$

$$B = \left\{ \left[ \begin{array}{c} a_1 \\ a_2 \\ a_3 \\ \vdots \\ a_9 \end{array} \right] \mid a_i \in \right.$$

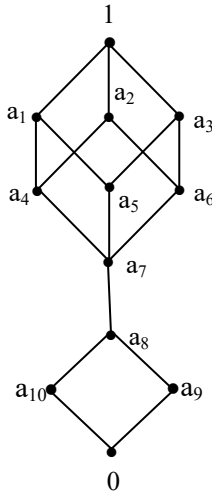

$\{1 \leq i \leq 9\}$  be the subset semiring.  $o(S) < \infty$ .

S has subset set ideal semiring topological spaces over the subsemirings of B.

**Example 4.63:** Let  $S = \{\text{Collection of all subsets from the matrix semiring}$

$$B = \left\{ \left[ \begin{array}{cccc} a_1 & a_2 & \dots & a_7 \\ a_8 & a_9 & \dots & a_{14} \\ a_{15} & a_{16} & \dots & a_{21} \\ a_{22} & a_{23} & \dots & a_{28} \end{array} \right] \mid a_i \in L \text{ a Boolean algebra of order } \right.$$

$2^8 = 256\}$  be the subset semiring.  $o(S) < \infty$ .

S has subset set semiring ideal topological spaces of finite order over the subsemiring  $P_i$  of B.



**Example 4.64:** Let  $S = \{\text{Collection of all subsets from the semiring}\}$

$$M = \left[ \begin{array}{ccccc} a_1 & a_2 & a_3 & a_4 & a_5 \\ a_6 & a_7 & \dots & \dots & a_{10} \\ a_{11} & a_{12} & \dots & \dots & a_{15} \\ a_{16} & a_{17} & \dots & \dots & a_{20} \\ a_{21} & a_{22} & \dots & \dots & a_{25} \end{array} \right] \quad a_i \in L =$$

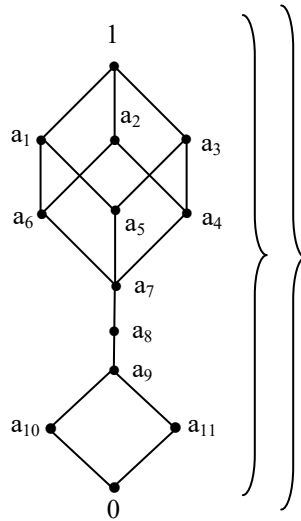

be the subset semiring.  $\alpha(S) < \infty$ ,  $T_{\cup, P_i}^\times$ ,  $T_{\cap, P_i}^\times$  and  $T_{S, P_i}$  be three set subset ideal semiring topological spaces over the subsemiring  $P_i$  of  $B$ .

All these three spaces contain subset topological zero divisors.

**Example 4.65:** Let  $S = \{\text{collection of all subsets from the semiring } M = \{([a_1, b_1], [a_2, b_2], \dots, [a_7, b_7]) \mid a_i, b_i \in L =$

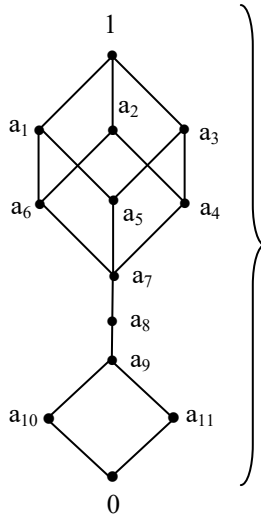

$1 \leq i \leq 7$  be the subset semiring  $\sigma(S) < \infty$ .

The three set ideal subset semiring topological spaces over semirings has topological subset zero divisors.

**Example 4.66:** Let  $S = \{\text{Collection of all subsets from the semiring}\}$

$$M = \left\{ \left[ \begin{array}{c} [a_1, b_1] \\ [a_2, b_2] \\ \vdots \\ [a_{14}, b_{14}] \end{array} \right] \right\} \quad a_i, b_i \in$$

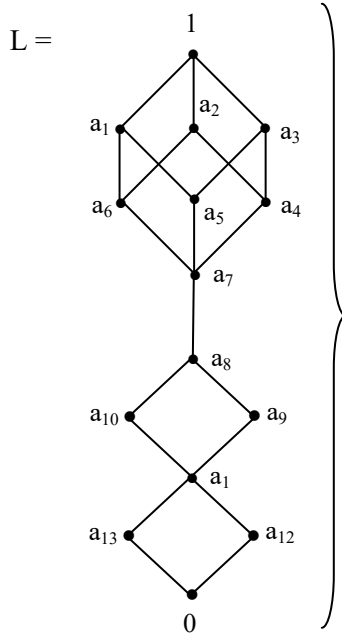

$1 \leq i \leq 14$  be the subset semiring.

We see the six subset ideal semiring topological spaces over the subsemiring of  $M$ .

Further  ${}_i T_{\cup}^{\times}$ ,  ${}_i T_{\cap}^{\times}$  and  ${}_i T_S$  are topological spaces such that they contain pairs of subspaces  $A, B$  such that

$$A \times B = \left\{ \begin{matrix} [[0,0]] \\ [0,0] \\ \vdots \\ [0,0] \end{matrix} \right\}.$$

**Example 4.67:** Let  $S = \{\text{Collection of all subsets from the}$

$$\text{interval semiring } M = \left\{ \begin{bmatrix} [a_1, b_1] & [a_2, b_2] \\ [a_3, b_3] & [a_4, b_4] \\ [a_5, b_5] & [a_6, b_6] \\ [a_7, b_7] & [a_8, b_8] \end{bmatrix} \right\} \mid a_i, b_i \in L =$$

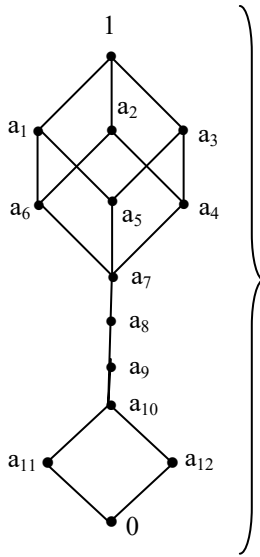

$1 \leq i \leq 8\}$  be the subset semiring  ${}_i T_o, {}_i T_\cup^\times, {}_i T_\cap^\times, {}_i T_\cup^+, {}_i T_\cap^+$  and  ${}_i T_S$  are the six subset set ideal semiring topological spaces over subsemiring  $P_i$  of  $M$ .

${}_i T_S, {}_i T_\cup^\times$  and  ${}_i T_\cap^\times$  are subset set ideal semiring topological spaces which have pair of subspaces  $A, B$  such that

$$A \times B = \left\{ \begin{bmatrix} [0,0] & [0,0] \\ [0,0] & [0,0] \\ [0,0] & [0,0] \\ [0,0] & [0,0] \end{bmatrix} \right\}.$$

**Example 4.68:** Let  $S = \{\text{Collection of all subsets from the}$

$$\text{interval semiring } M = \left\{ \begin{bmatrix} [a_1, b_1] & [a_2, b_2] & \dots & [a_7, b_7] \\ [a_8, b_8] & [a_9, b_9] & & [a_{14}, b_{14}] \\ \vdots & \vdots & & \vdots \\ [a_{43}, b_{43}] & [a_{44}, b_{44}] & \dots & [a_{49}, b_{49}] \end{bmatrix} \right\}_{a_i},$$

$$b_i \in L = \{1 \leq i \leq 49\}$$

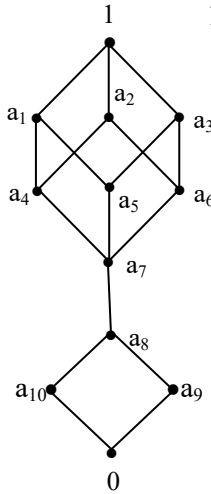

be the subset semiring.

The three set subset ideal semiring topological spaces over the subsemiring  $P_i, P_i T_S, P_i T_{\cup}^{\times}$  and  $P_i T_{\cap}^{\times}$  are such that we have a pair of subspaces  $A, B$  which are such that

$$A \times B = \left\{ \begin{bmatrix} [0,0] & [0,0] & \dots & [0,0] \\ [0,0] & [0,0] & \dots & [0,0] \\ \vdots & \vdots & & \vdots \\ [0,0] & [0,0] & \dots & [0,0] \end{bmatrix} \right\}.$$

These spaces have subset topological zero divisors.

We have also subset semiring which are built using super matrix semirings.

**Example 4.69:** Let  $S = \{\text{Collection of all subsets from the}$

$$\text{super matrix semiring } M = \left\{ \begin{array}{c} [a_1, b_1] \\ [a_2, b_2] \\ [a_3, b_3] \\ [a_4, b_4] \\ [a_5, b_5] \\ [a_6, b_6] \end{array} \right\} \quad a_i, b_i \in$$

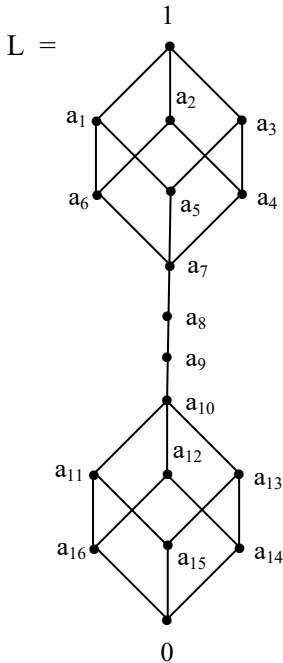

$1 \leq i \leq 6\}$ . Clearly  $o(S) < \infty$ .  $S$  has subset set ideal semiring topological spaces over subsemirings of  $M$  some of them have subset topological zero divisors.

**Example 4.70:** Let  $S = \{\text{Collection of all subsets from the super matrix interval semiring } M = \{([a_1, b_1] \mid [a_2, b_2], [a_3, b_3] \mid [a_4, b_4] [a_5, b_5] [a_6, b_6] \mid [a_7, b_7] [a_8, b_8]) \mid a_i, b_i \in L =$

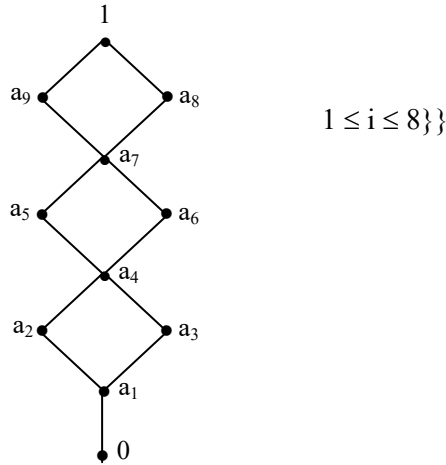

be the subset semiring.

$o(S) < \infty$ . This subset semiring has subset zero divisors and these set ideal subset semiring topological spaces have subset topological zero divisors.

**Example 4.71:** Let  $S = \{\text{Collection of all subsets from the super interval matrix semiring}$

$M =$

$$\left\{ \begin{array}{c|c|c|c|c|c} [a_1, b_1] & [a_2, b_2] & [a_3, b_3] & [a_4, b_4] & [a_5, b_5] & [a_6, b_6] \\ [a_7, b_7] & [a_8, b_8] & \dots & \dots & \dots & [a_{16}, b_{16}] \\ \hline [a_{17}, b_{17}] & [a_{18}, b_{18}] & \dots & \dots & \dots & [a_{24}, b_{24}] \\ \hline [a_{25}, b_{25}] & [a_{26}, b_{26}] & \dots & \dots & \dots & [a_{30}, b_{30}] \\ \hline [a_{31}, b_{31}] & [a_{32}, b_{32}] & \dots & \dots & \dots & [a_{36}, b_{36}] \\ \hline [a_{37}, b_{37}] & [a_{38}, b_{38}] & \dots & \dots & \dots & [a_{42}, b_{42}] \\ \hline [a_{43}, b_{43}] & [a_{44}, b_{44}] & \dots & \dots & \dots & [a_{49}, b_{49}] \end{array} \right\}$$

$a_i, b_i \in L$  a Boolean algebra of order  $2^5$ ;  $1 \leq i \leq 49$  be the subset semiring.  $o(S) < \infty$ .  $S$  has subset zero divisors and subset idempotents.

Now we give examples of non commutative interval subset semirings.

**Example 4.72:** Let  $S = \{\text{Collection of all subsets from the semiring}$

$$M = \left\{ \begin{bmatrix} [a_1, b_1] & [a_2, b_2] & \dots & [a_{10}, b_{10}] \\ [a_{11}, b_{11}] & [a_{12}, b_{12}] & \dots & [a_{20}, b_{20}] \\ [a_{21}, b_{21}] & [a_{22}, b_{22}] & \dots & [a_{30}, b_{30}] \\ [a_{31}, b_{31}] & [a_{32}, b_{32}] & \dots & [a_{40}, b_{40}] \\ [a_{41}, b_{41}] & [a_{42}, b_{42}] & \dots & [a_{50}, b_{50}] \end{bmatrix} \right\} a_i, b_i \in LS_3;$$

$L$  is Boolean algebra of order  $2^6$  be the subset semiring.  $S$  is non commutative and  $o(S) < \infty$ .

The three topological spaces  ${}_P T_S, {}_P T_U^\times$  and  ${}_P T_\cap^\times$  are non commutative.

**Example 4.73:** Let  $S = \{\text{Collection of all subsets from the semiring } L(S_4 \times D_{2,7})\}$ ;  $L$  a Boolean algebra of order  $2^5$ , be the subset semiring.

$S$  has non commutative set ideal subset semiring topological spaces over subsemirings of  $L(S_4 \times D_{2,7})$ .

**Example 4.74:** Let  $S = \{\text{Collection of all subsets from the semiring } (L_1 \times L_2)A_5$  where



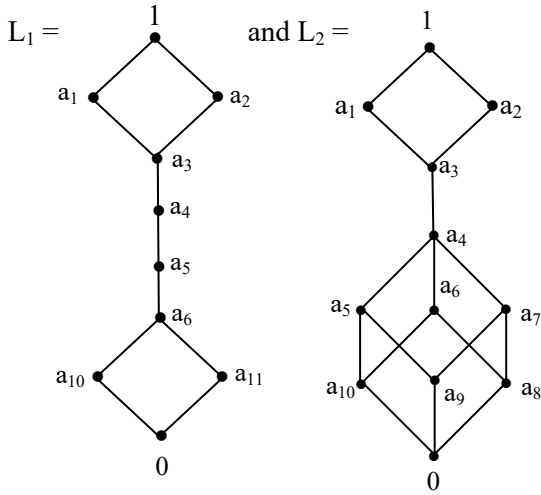

be the subset semiring which is non commutative.

**Example 4.75:** Let  $S = \{\text{Collection of all subsets from the semiring } L(S_7 \times D_{2,5} \times A_{10})\}$  where  $L$  is the lattice

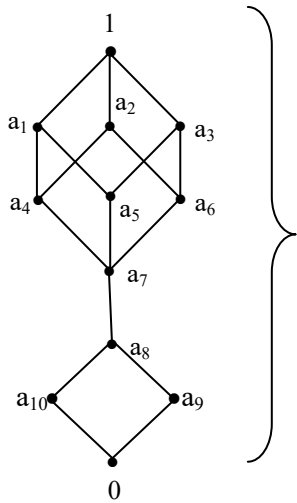

$S$  is a finite non commutative subset semiring.

S has subset zero divisors. The set subset ideal topological semiring spaces over subsemirings have subset topological zero divisors.

**Example 4.76:** Let  $S = \{\text{Collection of all subsets from the semiring } LS(3) \text{ where } L =$

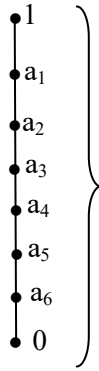

the subset semiring.  $o(S) < \infty$ .

S is a non commutative subset semiring.

The three subset set ideal semiring topological spaces  ${}_{P_1}T_0$ ,  ${}_{P_1}T_{\cup}^{\times}$  and  ${}_{P_1}T_{\cap}^{\times}$  are non commutative over the subsemiring  $P_1$  of  $LS(3)$ .

These topological spaces contain subset idempotents and has no subset topological zero divisors.

**Example 4.77:** Let  $S = \{\text{Collection of all subsets from the semiring } (L_1 \times L_2) S_7 \text{ where } L_1 \text{ is a Boolean algebra of order } 2^5 \text{ and } L_2 \text{ is the following lattice}$

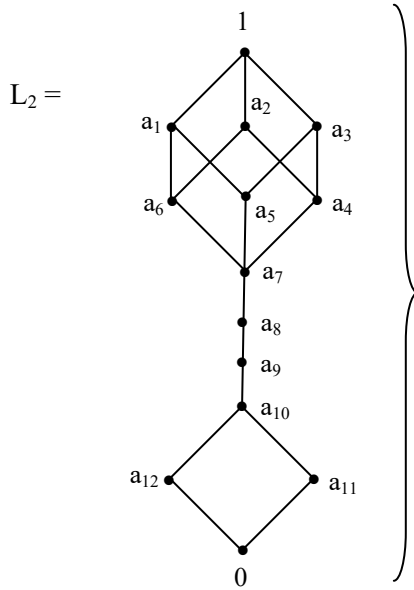

be the subset semiring;  $o(S) < \infty$ .

S has subset zero divisors. S is non commutative.

S has non commutative subset set ideal semiring topological spaces of finite order.

**Example 4.78:** Let  $S = \{\text{Collection of all subsets from the semiring } M = L(S(4) \times D_{2,5})\}$  be the subset semiring where  $L =$

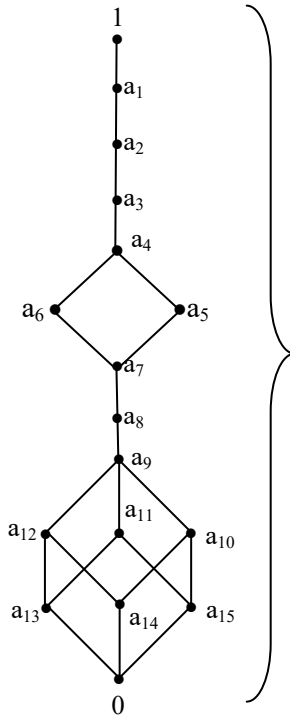

$\sigma(S) < \infty$  and  $S$  is non commutative.

$S$  has subset zero divisors and subset idempotents.

Thus the subset set ideal topological spaces of  $S$  has subset topological zero divisors.

**Example 4.79:** Let  $S = \{\text{Collection of all subsets from the } (L_1 \times L_2 \times L_3) (S(4) \times D_{2,7}); \text{ where}$

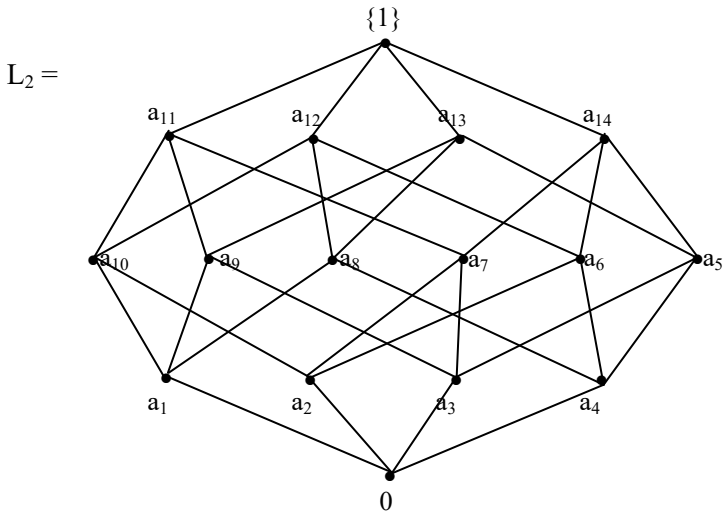
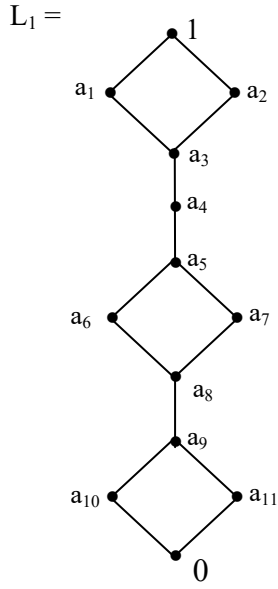

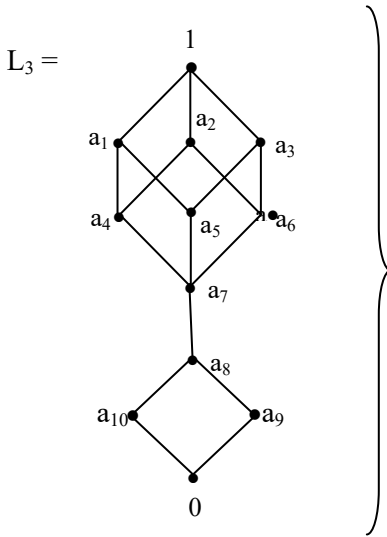

be the subset semiring;  $o(S) < \infty$ .  $S$  has subset zero divisors.

Now we proceed onto describe interval subset semirings of type II using interval semirings.

**Example 4.80:** Let  $S = \{\text{Collection of all subsets from the interval lattice } M = \{[a, b] \mid a, b \in L =$

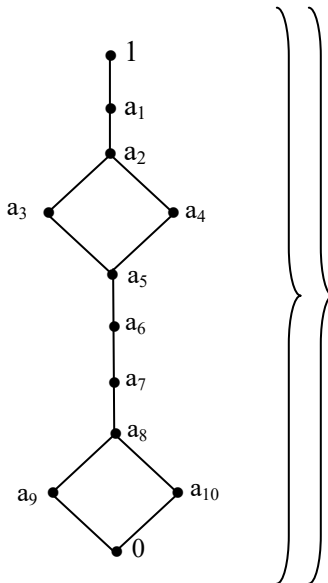

be the interval semiring.  $o(S) < \infty$ . Clearly  $S$  has subset set ideal topological semiring spaces over subsemirings  $P_i$  of  $M$  given by  ${}_{P_i}T_o, {}_{P_i}T_{\cup}^{\times}, {}_{P_i}T_{\cap}^{\times}, {}_{P_i}T_{\cup}^+, {}_{P_i}T_{\cap}^+$  and  ${}_{P_i}T_S$ .

We see all the six spaces are distinct and  ${}_{P_i}T_{\cup}^{\times}, {}_{P_i}T_{\cap}^{\times}$  and  ${}_{P_i}T_S$  have pairs of subspaces  $A, B$  such that  $A \times B = \{[0, 0]\}$ . Also these three spaces have subset interval topological zero divisors which are of finite in number.

**Example 4.81:** Let  $S = \{\text{Collection of all subsets from the interval semiring } M = \{[a_i, b_i] \mid a_i, b_i \in LS(3) \text{ where } L =$

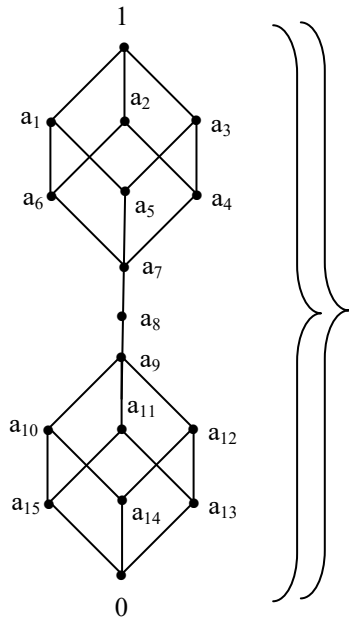

be the subset semiring.  $S$  is non commutative.

We see the subset ideal semiring topological spaces are of finite order and  ${}_{P_i}T_S, {}_{P_i}T_{\cup}^{\times}$  and  ${}_{P_i}T_{\cap}^{\times}$  are of finite order and non commutative. Also all these three spaces have pairs of subspaces  $A, B$  with  $A \times B = \{[0, 0]\}$  and these three spaces have subset topological zero divisors.

**Example 4.82:** Let  $S = \{\text{Collection of all subsets from the interval matrix semiring } M = \{([a_1, b_1], [a_2, b_2], [a_3, b_3], [a_4, b_4], [a_5, b_5]) \mid a_i, b_i \in L \text{ where } L =$

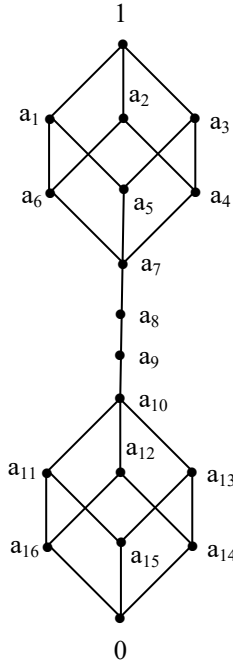

$1 \leq i \leq 5\}$  be the subset interval semiring.  $S$  has subset idempotents and subset zero divisors.

Further if  $P_i$  is any interval subset subsemiring of  $M$  then the three topological spaces  ${}_P T_S, {}_P T_{\cup}^{\times}$  and  ${}_P T_{\cap}^{\times}$  have pairs of subspaces  $A, B$  with  $A \times B = \{([0, 0], [0, 0], [0, 0], [0, 0], [0, 0])\}$ . However  ${}_P T_{\cup}^{\times}, {}_P T_{\cap}^{\times}$  and  ${}_P T_S$  contain subset topological zero divisors.

Further  $o({}_P T_{\cup}^{\times}), o({}_P T_{\cap}^{\times})$  and  $o({}_P T_S)$  are finite.

**Example 4.83:** Let  $S = \{\text{Collection of all subsets from the semiring } M = \{([a_1, b_1], [a_2, b_2] \dots, [a_{10}, b_{10}]) \mid a_i, b_i \in LS_5 \text{ where } L =$



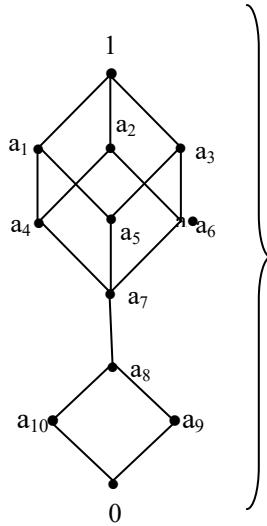

$1 \leq i \leq 10$  be the subset interval semiring. Clearly  $o(S) < \infty$  and  $S$  is a non commutative interval subset semiring.

Now if  $P_i$  is interval subsemiring of the semiring  $LS(5)$  then  ${}_i T_{\cup}^{\times}$ ,  ${}_i T_{\cap}^{\times}$  and  ${}_i T_S$  are of finite order and are non commutative.

These three subset set ideal interval semiring topological spaces have pairs of subspaces  $A, B$  with  $A \times B = \{([0, 0], [0, 0], [0, 0], \dots, [0, 0])\}$ . Also these three spaces have subset interval topological zero divisors.

**Example 4.84:** Let  $S = \{\text{Collection of all subsets from the semiring}\}$

$$M = \left\{ \begin{bmatrix} [a_1, b_1] \\ [a_2, b_2] \\ \vdots \\ [a_{12}, b_{12}] \end{bmatrix} \mid a_i, b_i \in L = \right.$$

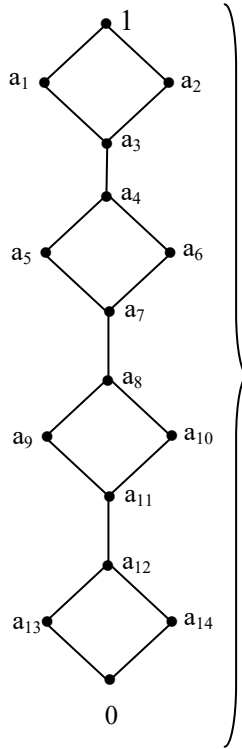

$1 \leq i \leq 12\}$  be the subset semiring.

$S$  has subset set ideal interval semiring topological spaces over subsemiring  $P_i$  of  $L$ .  ${}_i T_{\cup}^{\times}$ ,  ${}_i T_{\cap}^{\times}$  and  ${}_i T_S$  are all of finite order commutative and have subset topological zero divisors subset idempotents.

**Example 4.85:** Let  $S = \{\text{Collection of all subsets from the interval semiring } M = \{[a, b] \mid a, b \in LS_3 \times D_{2,11} \text{ where } L \text{ is a Boolean algebra of order } 2^6\}\}$  be the subset semiring.  $o(S) < \infty$ .  $S$  is non commutative.  $S$  has subset zero divisors as well as subset topological zero divisors. Infact the spaces  ${}_i T_{\cup}^{\times}$ ,  ${}_i T_{\cap}^{\times}$  and  ${}_i T_S$ ; the set subset ideal topological semiring spaces have pairs of subspaces  $A, B$  such that  $A \times B = \{[0, 0]\}$ .

**Example 4.86:** Let  $S = \{\text{Collection of all subsets form the}$

interval matrix semiring  $M = \left\{ \begin{bmatrix} [a_1, b_1] \\ [a_2, b_2] \\ \vdots \\ [a_{12}, b_{12}] \end{bmatrix} \mid a_i, b_i \in LS(4); 1 \leq i \right.$

$\leq 12$  where  $L =$

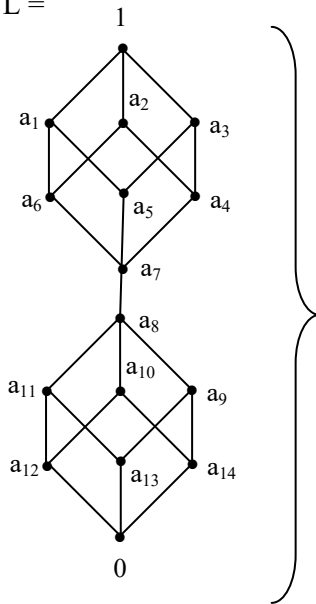

the subset semiring.  $o(S) < \infty$ .  $S$  is non commutative.  $S$  has subset zero divisors. Also  $S$  has subset idempotents. The set ideal subset topological semiring spaces  ${}_P T_{\cup}^{\times}$ ,  ${}_P T_{\cap}^{\times}$  and  ${}_P T_S^{\times}$  have pairs of subspaces  $A, B$  such that

$$A \times B = \left\{ \begin{bmatrix} [0, 0] \\ [0, 0] \\ \vdots \\ [0, 0] \end{bmatrix} \right\}.$$

**Example 4.87:** Let  $S = \{\text{Collection of all subsets form the interval matrix semiring}\}$

$$M = \left\{ \begin{bmatrix} [a_1, b_1] & [a_2, b_2] & [a_3, b_3] \\ [a_4, b_4] & [a_5, b_5] & [a_6, b_6] \\ \vdots & \vdots & \vdots \\ [a_{28}, b_{28}] & [a_{29}, b_{29}] & [a_{30}, b_{30}] \end{bmatrix} \right\} \text{ where } a_i, b_i \in LS_7$$

where  $L =$

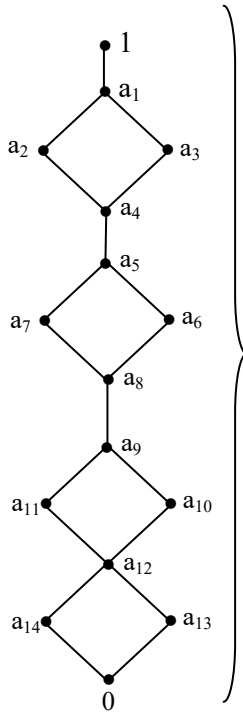

be the subset semiring.  $o(S) < \infty$ .  $S$  is non commutative and  $S$  has subset zero divisors and topological subset zero divisors.

**Example 4.88:** Let  $S = \{\text{Collection of all subsets from the interval matrix semiring}\}$

$$M = \left\{ \left[ \begin{array}{cccc} [a_1, b_1] & [a_2, b_2] & [a_3, b_3] & [a_4, b_4] \\ \vdots & \vdots & \vdots & \vdots \\ [a_{13}, b_{13}] & [a_{14}, b_{14}] & [a_{15}, b_{15}] & [a_{16}, b_{16}] \end{array} \right] \mid a_i, b_i \in LD_{2,13} \right\}$$

where  $L =$

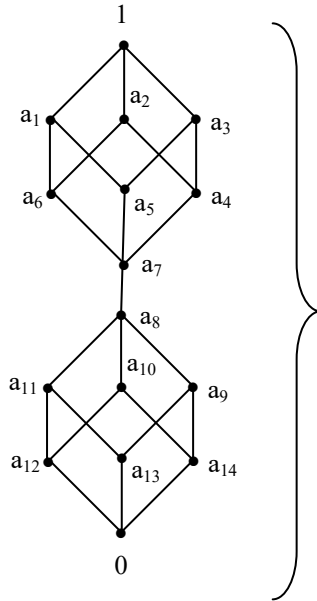

be the subset semiring  $o(S) < \infty$ .  ${}_P T_{\cup}^{\times}$ ,  ${}_P T_{\cap}^{\times}$  and  ${}_P T_S$  have subset topological spaces which has subset topological zero divisors.

**Example 4.89:** Let  $S = \{ \text{Collection of all subsets from the super interval matrix semiring } M = \{ ([a_1, b_1] \mid [a_2, b_2] \mid [a_3, b_3] \mid [a_4, b_4]) \mid a_i, b_i \in L (S_3 \times D_{2,7}); 1 \leq i \leq 4, L \text{ is a chain lattice } C_{10} \} \}$  be the subset semiring.  $o(S) < \infty$ .

Inview of all these we state the following theorem.

**THEOREM 4.4:** *Let*

$S = \{\text{Collection of all subsets from the interval semiring}\}$  be the subset semiring

(i)  $S$  has subset zero divisors and subset topological zero divisors. (ii)  ${}_P T_{\cup}^{\times}$ ,  ${}_P T_{\cap}^{\times}$  and  ${}_P T_S$  have pairs of subset set ideal semiring topological subspaces  $A, B$  with  $A \times B = \{([0, 0])\}$ .

The proof is direct and hence left as an exercise to the reader.

We now proceed onto propose the following problem for the reader.

**Problems:**

1. Obtain some special and interesting results about the six subset set ideal semiring topological spaces over a subring of a ring.
2. Characterize those rings in which atleast three of the six topological spaces are identical.
3. Does there exist a ring for which all the six topological spaces are identical?
4. Find conditions on the ring so that all the six topological spaces are distinct.
5. Let  $S = \{\text{Collection of all subsets from the ring } Z_{12}\}$  be the subset semiring.
  - (i) Find  $o(S)$ .
  - (ii) Find all subset set ideal semiring special topological spaces;  ${}_P T_o$ ,  ${}_P T_{\cup}^{\times}$ ,  ${}_P T_{\cap}^{\times}$ ,  ${}_P T_{\cup}^{+}$ ,  ${}_P T_{\cap}^{+}$  and  ${}_P T_S$  over a subring  $P_1 \subseteq Z_{12}$ .

- (iii) Find all set ideal subset semiring topological zero divisors of  $S$ .
6. Let  $S = \{\text{Collection of all subsets from the ring } Z_{19}\}$  be the subset semiring.
- (i) Study questions (i) and (ii) of problem 5 for this  $S$ .
  - (ii) Can  $S$  have subset zero divisors?
  - (iii) Is  $S$  a subset semifield?

7. Let  $S = \{\text{Collection of all subsets from the ring } M = Z_{15} \times Z_{46}\}$  be the subset semiring.

Study questions (i) and (iii) of problem 6 for this  $S$ .

8. What are the special features enjoyed by the subset interval semiring built using interval semiring?
9. Let  $S = \{\text{Collection of all subsets from the ring } Z_5S_7\}$  be the subset semiring.
- (i) Find  $o(S)$ .
  - (ii) Find all the six subset set ideal semiring topological spaces over subrings.
  - (iii) Show  $S$  is non commutative.
  - (iv) Prove the set ideal subset semiring topological spaces  ${}_P_i T_S$ ,  ${}_P_i T_\cup^\times$  and  ${}_P_i T_\cap^\times$  are non commutative space over  $P_i$  the subring of  $M$ .
  - (v) Find all subset set ideal semiring topological subspaces of  ${}_P_i T_S$ ,  ${}_P_i T_\cup^\times$  and  ${}_P_i T_\cap^\times$  which are commutative over the subring  $P_i$ .
  - (vi) Does  ${}_P_i T_S$ ,  ${}_P_i T_\cup^\times$  and  ${}_P_i T_\cap^\times$  have subset topological zero divisors?
  - (vii) Can  ${}_P_i T_S$ ,  ${}_P_i T_\cup^\times$  and  ${}_P_i T_\cap^\times$  have pairs of subset set ideal semiring subspaces  $A$ ,  $B$  such that  $A \times B = \{(0)\}$ .

10. Let  $S = \{\text{Collection of all subsets from the ring } Z_{40}D_{2,8}\}$  be the subset semiring of type I.

Study questions (i) and (vii) of problem 9 for this S.

11. Let  $S = \{\text{Collection of all subsets from the ring } (Z_{12} \times Z_{35}) (S(4) \times (D_{2,5}))\}$  be the subset semiring.

Study questions (i) and (vii) of problem 9 for this S.

12. Let  $S = \{\text{Collection of all subsets from the matrix ring } M = \{(a_1, a_2, a_3, \dots, a_{12}) \mid a_i \in Z_{48} D_{2,8}; 1 \leq i \leq 12\}\}$  be the subset semiring.

Study questions (i) and (vii) of problem 9 for this S.

13. Let  $S = \{\text{Collection of all subsets from the matrix ring}$

$$M = \left\{ \left[ \begin{array}{c} a_1 \\ a_2 \\ \vdots \\ a_9 \end{array} \right] \mid a_i \in Z_{19}, A_5; 1 \leq i \leq 9 \right\} \text{ be the subset}$$

semiring of type I.

Study questions (i) and (vii) of problem 9 for this S.

14. Let  $S = \{\text{Collection of all subsets from the matrix ring}$

$$M = \left\{ \left[ \begin{array}{cccc} a_1 & a_2 & \dots & a_{10} \\ a_{11} & a_{12} & \dots & a_{20} \\ a_{21} & a_{22} & \dots & a_{30} \\ a_{31} & a_{32} & \dots & a_{40} \end{array} \right] \mid a_i \in (Z_{10} \times Z_{51}) S_3,$$

$$1 \leq i \leq 40 \}$$



be the subset semiring.

Study questions (i) and (vii) of problem 9 for this S.

15. Let  $S = \{\text{Collection of all subsets from the matrix ring}$

$$M = \left\{ \left[ \begin{array}{cccc} a_1 & a_2 & \dots & a_5 \\ a_6 & a_7 & \dots & a_{10} \\ a_{11} & a_{12} & \dots & a_{15} \\ a_{16} & a_{17} & \dots & a_{20} \\ a_{21} & a_{22} & \dots & a_{25} \end{array} \right] \mid a_i \in (\mathbb{Z}_{11} \times \mathbb{Z}_7) S_7, 1 \leq i \leq 25 \right\}$$

be the subset semiring of type I.

Study questions (i) and (vii) of problem 9 for this S.

16. Let  $S = \{\text{Collection of all subsets from the super matrix}$

$$\text{ring } M = \left\{ \left[ \begin{array}{c} a_1 \\ a_2 \\ a_3 \\ a_4 \\ a_5 \\ a_6 \\ a_7 \\ a_8 \\ a_9 \\ a_{10} \\ a_{11} \end{array} \right] \mid a_i \in \mathbb{Z}_{25} (D_{2,7} \times A_5); 1 \leq i \leq 11 \right\} \text{ be a}$$

subset semiring of type I.

Study questions (i) and (vii) of problem 9 for this S.

17. Let  $S = \{\text{Collection of all subsets from the super matrix ring } M = \{(a_1 \mid a_2 \ a_3 \mid a_4 \ a_5 \ a_6 \mid a_7 \ a_8 \mid a_9) \mid a_i \in Z_5 (A_5 \times D_{2,11}); 1 \leq i \leq 9\}\}$  be the subset semiring of type I.

Study questions (i) and (vii) of problem 9 for this S.

18. Let  $S = \{\text{Collection of all subsets from the super matrix}$

$$M = \left\{ \left[ \begin{array}{cc|cc|c|cc|c} a_1 & a_2 & a_3 & a_4 & a_5 & a_6 & a_7 & a_8 \\ a_9 & a_{10} & \dots & \dots & \dots & \dots & \dots & a_{16} \\ a_{17} & a_{18} & \dots & \dots & \dots & \dots & \dots & a_{24} \\ a_{25} & a_{26} & \dots & \dots & \dots & \dots & \dots & a_{32} \\ a_{33} & a_{34} & \dots & \dots & \dots & \dots & \dots & a_{40} \end{array} \right] \mid a_i \in Z_{15} \right\}$$

$(A_4 \times D_{2,11}); 1 \leq i \leq 40\}$  be the subset semiring.

Study questions (i) and (vii) of problem 9 for this S.

19. Let  $S = \{\text{Collection of all subsets from the ring } R\}$  be the subset semiring.

- (i) Find the subset semiring set ideal topological spaces  ${}_P_i T_o, {}_P_i T_\cup^\times, {}_P_i T_\cap^\times, {}_P_i T_\cup^+, {}_P_i T_\cap^+$  and  ${}_P_i T_S$  over the subrings  $P_i$  of  $R$ .
- (ii) Find subspaces of the topological spaces given in (i).
- (iii) Show these spaces have subset topological zero divisors.
- (iv) Prove all the topological spaces are commutative.
- (v) Show on  $S$  we can have infinite number of set ideal subset semiring topological spaces defined over the subrings.

20. Let  $S = \{\text{Collection of all subsets from the ring } \langle Q \cup I \rangle\}$  be the subset semiring.

Study questions (i) and (v) of problem 19 for this S.

21. Let  $S = \{\text{Collection of all subsets from the ring } \langle C \cup I \rangle S_3\}$  be the subset semiring.

- (i) Study questions (i) and (v) of problem 19 for this  $S$ .
- (ii) Prove  $S$  is non commutative.
- (iii) Prove the set ideal subset semiring topological spaces  ${}_P_i T_S, {}_P_i T_{\cup}^{\times}$  and  ${}_P_i T_{\cap}^{\times}$  over the subring  $P_i$  of  $\langle C \cup I \rangle S_3$  are non commutative.

22. Let  $S = \{\text{Collection of all subsets from the ring } (Z \times Z \times Z)S_7\}$  be the subset semiring.

- (i) Study questions (i) and (v) of problem 19 for this  $S$ .
- (ii) Prove  ${}_P_i T_S, {}_P_i T_{\cup}^{\times}$  and  ${}_P_i T_{\cap}^{\times}$  has pairs of subspaces  $A, B$  such that  $A \times B = \{(0)\}$ .

23. Let  $S = \{\text{Collection of all subsets from the ring } M = \{(a_1, a_2, \dots, a_9) \mid a_i \in \langle Z \cup I \rangle D_{2,11}, 1 \leq i \leq 9\}\}$  be the subset semiring.

Study questions (i) and (ii) of problem 22 for this  $S$ .

24. Let  $S = \{\text{Collection of all subsets from the matrix ring}$

$$M = \left\{ \left[ \begin{array}{c} a_1 \\ a_2 \\ a_3 \\ \vdots \\ a_{11} \\ a_{12} \end{array} \right] \mid a_i \in ZS_{11}; 1 \leq i \leq 12 \right\} \text{ be the subset}$$

semiring.

Study questions (i) and (ii) of problem 22 for this  $S$ .



27. Let  $S = \{\text{Collection of all subsets from the super matrix}$

$$\text{ring } M = \left\{ \left[ \begin{array}{cccc|cc} a_1 & a_2 & a_3 & a_4 & a_5 & a_6 \\ a_7 & \dots & \dots & \dots & \dots & a_{12} \\ a_{13} & \dots & \dots & \dots & \dots & a_{18} \\ a_{19} & \dots & \dots & \dots & \dots & a_{24} \\ \hline a_{25} & \dots & \dots & \dots & \dots & a_{30} \\ a_{31} & \dots & \dots & \dots & \dots & a_{36} \end{array} \right] \right\} \quad a_i \in \langle \mathbb{Z} \cup I \rangle$$

$(g_1, g_2, g_3) S_7; 1 \leq i \leq 36; g_1^2 = 0, g_2^2 = g_2, g_3^2 = -g_3, g_i g_j = g_j g_i = 0, 1 \leq i, j \leq 3\}$  be the subset semiring.

Study questions (i) and (iii) of problem 26 for this  $S$ .

28. Let  $S = \{\text{Collection of all subsets from the interval ring } M = \{([a_1, b_1], [a_2, b_2], \dots, [a_9, b_9]) \mid a_i, b_i \in \mathbb{Z}S_3 \times D_{2,11}; 1 \leq i \leq 9\}\}$  be the subset semiring.

Study questions (i) and (iii) of problem 26 for this  $S$ .

29. Let  $S = \{\text{Collection of all subsets from the interval ring}$

$$M = \left\{ \left[ \begin{array}{cccc} [a_1, b_1] & [a_2, b_2] & \dots & [a_7, b_7] \\ [a_8, b_8] & [a_9, b_9] & \dots & [a_{14}, b_{14}] \\ [a_{15}, b_{15}] & [a_{16}, b_{16}] & \dots & [a_{21}, b_{21}] \end{array} \right] \right\} \quad a_i, b_i \in (\mathbb{Z} \times \mathbb{Z}$$

$\times \mathbb{Z}) S(5), 1 \leq i \leq 21\}$  be the subset semiring.

Study questions (i) and (iii) of problem 26 for this  $S$ .

30. Let  $S = \{\text{Collection of all subsets from the interval matrix}$

$$\text{ring } M = \left\{ \begin{bmatrix} [a_1, b_1] & [a_2, b_2] & \dots & [a_8, b_9] \\ [a_9, b_9] & [a_{10}, b_{10}] & \dots & [a_{16}, b_{16}] \\ [a_{17}, b_{17}] & [a_{18}, b_{18}] & \dots & [a_{24}, b_{24}] \\ [a_{25}, b_{25}] & [a_{26}, b_{26}] & \dots & [a_{32}, b_{32}] \\ [a_{33}, b_{33}] & [a_{34}, b_{34}] & \dots & [a_{40}, b_{40}] \\ [a_{41}, b_{41}] & [a_{42}, b_{42}] & \dots & [a_{48}, b_{48}] \\ [a_{49}, b_{49}] & [a_{50}, b_{50}] & \dots & [a_{56}, b_{56}] \\ [a_{57}, b_{57}] & [a_{58}, b_{58}] & \dots & [a_{64}, b_{64}] \end{bmatrix} \right\} a_i, b_i \in$$

$\langle C \cup I \rangle (S_7 \times D_{2,8} \times A_{11})\}$  be the subset semiring.

Study questions (i) and (iii) of problem 26 for this  $S$ .

31. Let  $S = \{\text{Collection of all subsets from the polynomial ring } R[x], R \text{ reals}\}$  be the subset semiring.

- (i) Show  $S$  has no subset zero divisors.
- (ii) Is  $S$  commutative?
- (iii) Show  $S$  has infinite number of subset set ideal topological semiring subspaces.
- (iv) Prove  $R[x]$  has infinite number of subrings.

32. Let  $S = \{\text{Collection of all subsets from the ring } \langle R \cup I \rangle[x]\}$  be the subset semiring.

Study questions (i) and (iv) of problem 31 for this  $S$ .

33. Let  $S = \{\text{Collection of all subsets from the ring } R[x_1, x_2, x_3] \mid x_i x_j = x_j x_i = i \neq j, 1 \leq i, j \leq 3\}$  be the subset semiring.

Study questions (i) and (iv) of problem 31 for this  $S$ .

34. Let  $S = \{\text{Collection of all subsets from the ring}$

$$M = \left\{ \sum_{i=0}^{\infty} [a_i, b_i] x^i \mid a_i, b_i \in \langle C \cup I \rangle \right\}$$

be the subset semiring.

- (i) Prove  $S$  has subset zero divisors.
- (ii) Study questions (i) and (iv) of problem 31 for this  $S$ .

35. Let  $S = \{\text{Collection of all subsets from the interval polynomial ring } R = \langle C \cup I \rangle \times \langle C \cup I \rangle (x_1, x_2)\}$

- (i) Study questions (i) and (ii) of problem 34 for this  $S$ .

36. Let  $S = \{\text{Collection of all subsets from the groupring } \langle R \cup I \rangle S_7 \times A_4\}$  be the subset semiring.

Study questions (i) and (ii) of problem 34 for this  $S$ .

37. Let  $S = \{\text{Collection of all subsets from the interval matrix}$

$$M = \left\{ \sum_{i=0}^{\infty} [a_i, b_i] x^i \mid a_i, b_i \in RS(5) \right\}$$

be the subset semiring.

Study questions (i) and (ii) of problem 34 for this  $S$ .

38. Let  $S = \{\text{Collection of all subsets from the semiring } L =$

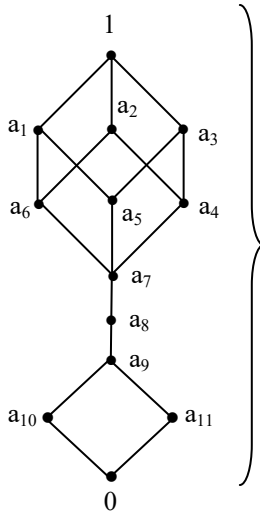

be the subset semiring of type II.

- (i) Find  $o(S)$ .
- (ii) Find all subsemirings of  $L$ .
- (iii) Find all set ideal subset semiring topological spaces of  $S$ .
- (iv) Prove  $S$  has subset idempotents.
- (v) Prove  $S$  has subset zero divisors.

39. Let  $S = \{\text{Collection of all subsets from the semiring } LS_7$  where  $L$  is as follows:



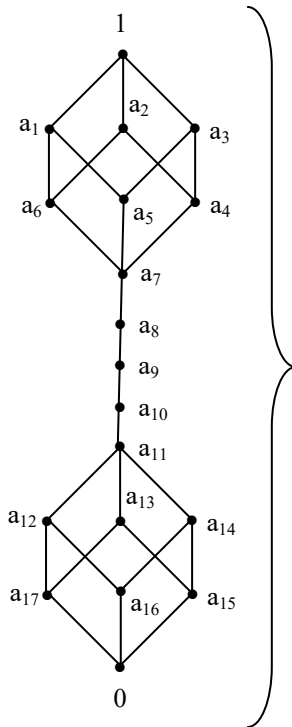

be the subset semiring.

- (i) Study questions (i) and (v) of problem 38 for this  $S$ .
- (ii) Prove the topological spaces  ${}_p T_S$ ,  ${}_p T_{\cup}^{\times}$  and  ${}_p T_{\cap}^{\times}$  are non commutative in general.

40. Let  $S = \{\text{Collection of all subsets from the semiring } L_1 \times L_2, \text{ where}$

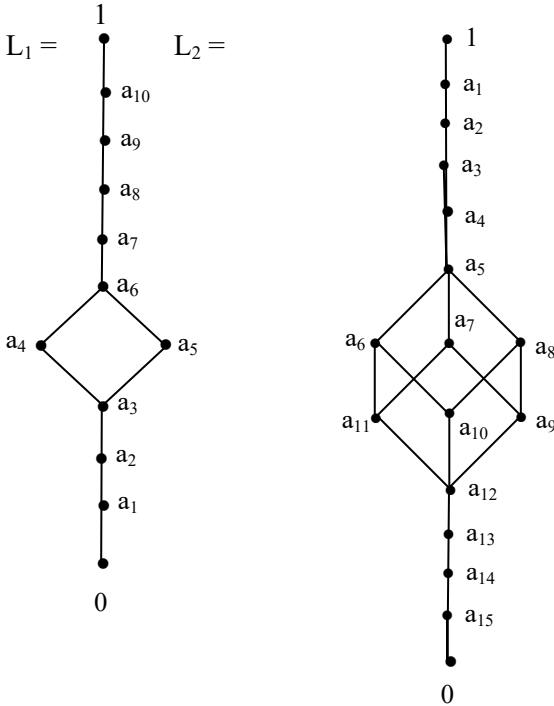

be the subset semiring of type II.

Study questions (i) and (v) of problem 38 for this S.

41. Let  $S = \{\text{Collection of all subsets from the semiring } LS(5) \text{ where } L \text{ is a Boolean algebra of order } 32\}$  be the subset semiring of type II.

- (i) Study questions (i) and (v) of problem 38 for this S.
- (ii) Prove S is non commutative.

42. Let  $S = \{\text{Collection of all subsets from the semiring } M = \{(a_1, a_2, \dots, a_6) \mid a_i \in L, \text{ where } L \text{ is a lattice}\}$

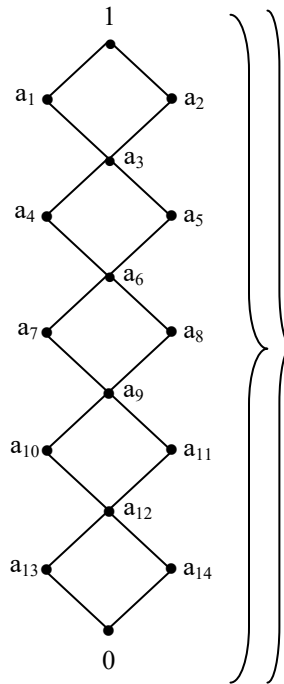

be the subset semiring of type II.

Study questions (i) and (v) of problem 38 for this  $S$ .

43. Let  $S = \{\text{Collection of all subsets from the semiring}$

$$M = \left\{ \left[ \begin{array}{c} a_1 \\ a_2 \\ \vdots \\ a_{10} \end{array} \right] \mid a_i \in L \right\}$$

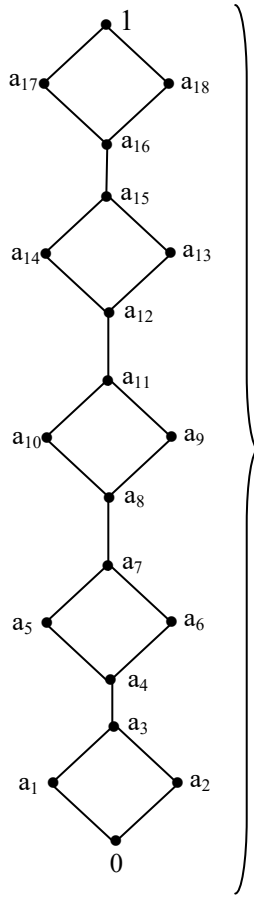

where  $1 \leq i \leq 10$  be the subset semiring.

Study questions (i) and (v) of problem 38 for this S.

44. Let  $S = \{\text{Collection of all subsets from the semiring } M =$

$$\left\{ \begin{bmatrix} a_1 & a_2 & \dots & a_{10} \\ a_{11} & a_{12} & \dots & a_{20} \\ a_{21} & a_{22} & \dots & a_{30} \\ a_{31} & a_{32} & \dots & a_{40} \end{bmatrix} \right\} \quad a_i \in L, L \text{ a Boolean algebra of}$$

order 64;  $1 \leq i \leq 40$  be the subset semiring.

Study questions (i) and (v) of problem 38 for this S.

45. Let  $S = \{\text{Collection of all subsets from the semiring}$

$$M = \left\{ \begin{bmatrix} a_1 & a_5 & a_9 & a_{13} \\ a_2 & a_6 & a_{10} & a_{14} \\ a_3 & a_7 & a_{11} & a_{15} \\ a_4 & a_8 & a_{12} & a_{16} \end{bmatrix} \right\} \quad a_i \in LS_4 \text{ where}$$

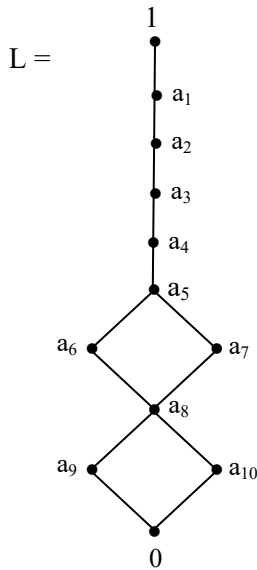

$1 \leq i \leq 16\}}\}$  be the subset semiring.

- (i) Study questions (i) and (v) of problem 38 for this S.
- (ii) Prove S is commutative.
- (iii) Prove the topological subset spaces,  ${}_P T_{\cup}^{\times}$ ,  ${}_P T_{\cap}^{\times}$  and  ${}_P T_S$  are non commutative.
- (iv) Find atleast two subset topological subspace of  ${}_P T_{\cup}^{\times}$ ,  ${}_P T_{\cap}^{\times}$  and  ${}_P T_S$  .

46. Let  $S = \{\text{Collection of all subsets from the semiring}\}$

$$M = \left\{ \begin{array}{ccc} \hline a_1 & a_2 & a_3 \\ a_4 & a_5 & a_6 \\ a_7 & a_8 & a_9 \\ \hline a_{10} & a_{11} & a_{12} \\ a_{13} & a_{14} & a_{15} \\ a_{16} & a_{17} & a_{18} \\ \hline \end{array} \right\} \quad a_i \in L(S(5) \times D_{2,7},$$

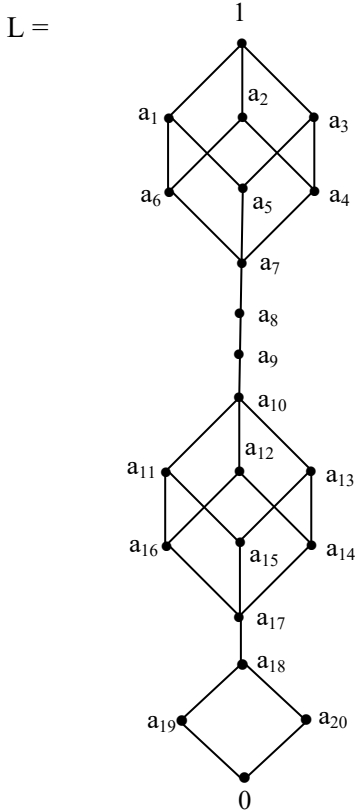

$1 \leq i \leq 18\}}\}$  be the subset semiring.

- (i) Study questions (i) and (v) of problem 38 for this S.
- (ii) Prove  ${}_P T_{\cup}^{\times}$ ,  ${}_P T_{\cap}^{\times}$  and  ${}_P T_S$  are all non commutative set ideal subset topological spaces of S over the subsemiring  $P_i$  of  $L(S(5) \times D_{2,7})$ .

47. Let  $S = \{\text{Collection of all subsets from the semiring } M = \{(a_1 | a_2 a_3 | a_4 a_5 a_6 | a_7 a_8 a_9) \mid \text{where } a_i \in L(S(4) \times D_{2,7}); 1 \leq i \leq 9\}\}$  be the subset semiring (L is a chain lattice  $C_{20}$ ).

- (i) Study questions (i) and (v) of problem 38 for this S.
- (ii) Prove S is non commutative.

48. Let  $S = \{\text{Collection of all subsets from the super matrix}$

$$\text{semiring } M = \left\{ \begin{bmatrix} a_1 \\ a_2 \\ a_3 \\ a_4 \\ a_5 \\ a_6 \\ a_7 \\ a_8 \\ a_9 \\ a_{10} \\ a_{11} \\ a_{12} \\ a_{13} \end{bmatrix} \mid a_i \in (L_1 \times L_2) D_{2,11} \right.$$

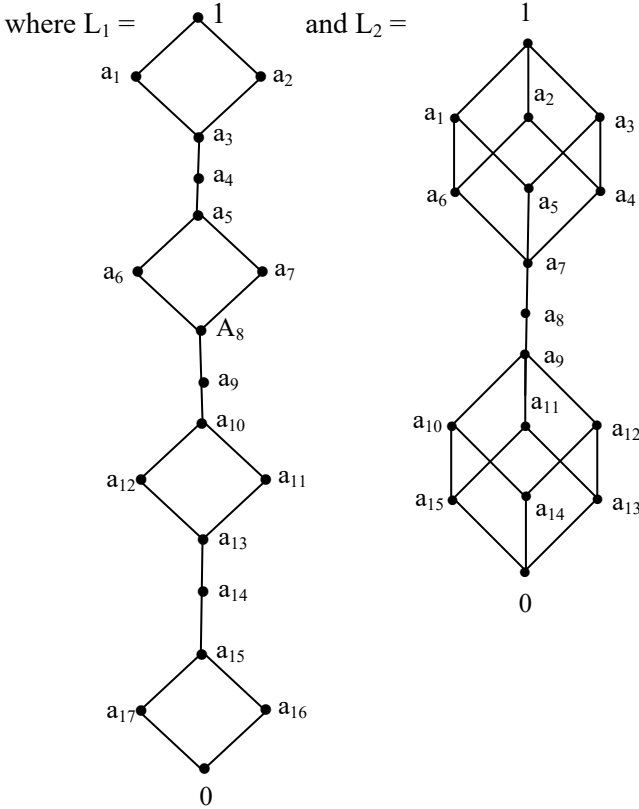

$1 \leq i \leq 13\}}\}$  be the subset semiring.

- (i) Study questions (i) and (v) of problem 38 for this S.
- (ii) Is S commutative?

49. Let  $S = \{\text{Collection of all subsets from the interval matrix semiring } M = \{([a_1, b_1], [a_2, b_2], [a_3, b_3], \dots, [a_{10}, b_{10}]) \mid a_i, b_i \in L(S_3 \times D_{2,7}); 1 \leq i \leq 10\}\}$  be the subset semiring.

- (i) Study questions (i) and (v) of problem 38 for this S.



- (ii) Prove S is non commutative.
- (iii) Prove S has subset topological zero divisors.
- (iv) Show  $T_{\cup}^{\times}$ ,  $T_{\cap}^{\times}$  and  $T_S$  has pairs of subspaces A, B with  $A \times B = \{([0, 0], [0, 0], \dots, [0, 0])\}$ .

50. Let  $S = \{\text{Collection of all subsets from the interval matrix semiring}$

$$M = \left\{ \begin{bmatrix} [a_1, b_1] & [a_2, b_2] & \dots & [a_{12}, b_{12}] \\ [a_{13}, b_{13}] & [a_{14}, b_{14}] & \dots & [a_{24}, b_{24}] \\ [a_{25}, b_{25}] & [a_{26}, b_{26}] & \dots & [a_{36}, b_{36}] \\ [a_{37}, b_{37}] & [a_{38}, b_{38}] & \dots & [a_{48}, b_{48}] \\ [a_{49}, b_{49}] & [a_{50}, b_{50}] & \dots & [a_{60}, b_{60}] \\ [a_{61}, b_{61}] & [a_{62}, b_{62}] & \dots & [a_{72}, b_{72}] \end{bmatrix} \right\} \quad a_i, b_i \in$$

$L(D_{2,13} \times S_8); L = C_{15}$  a chain lattice,  $1 \leq i \leq 72\}$  be the subset semiring.

Study questions (i) and (iv) of problem 49 for this S.

51. Let  $S = \{\text{Collection of all subsets from the semiring}$

$$M = \left\{ \sum_{i=0}^{\infty} [a_i, b_i] x^i \mid a_i, b_i \in LS(5) \text{ where } L \text{ is the lattice} \right.$$

given in the following

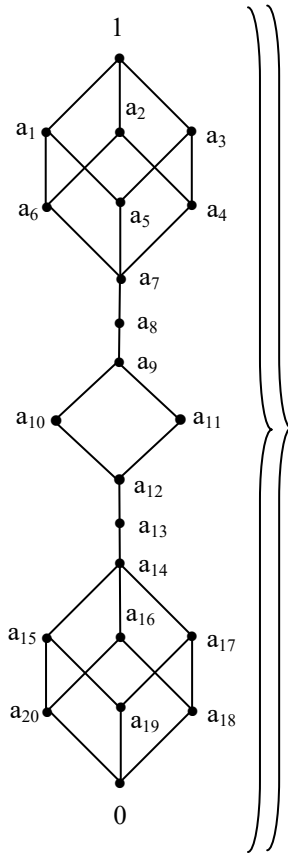

be the subset semiring.

- (i) Study questions (i) and (iv) of problem 49 for this  $S$ .
- (ii) Can  $S$  have infinite number of subset set ideal topological semiring spaces over the subsemiring of  $M$ ?
- (iii) Can  $S$  have infinite number of commutative subset set ideal semiring topological spaces over subsemiring of  $M$ ?
- (iv) Can  $M$  have infinite number of non commutative subsemiring?

52. Let  $S = \{\text{Collection of all subsets from the interval polynomial semiring } M = \left\{ \sum_{i=0}^{\infty} [a_i, b_i]x^i \mid a_i, b_i \in LD_{2,11} \right\}$  where  $L =$

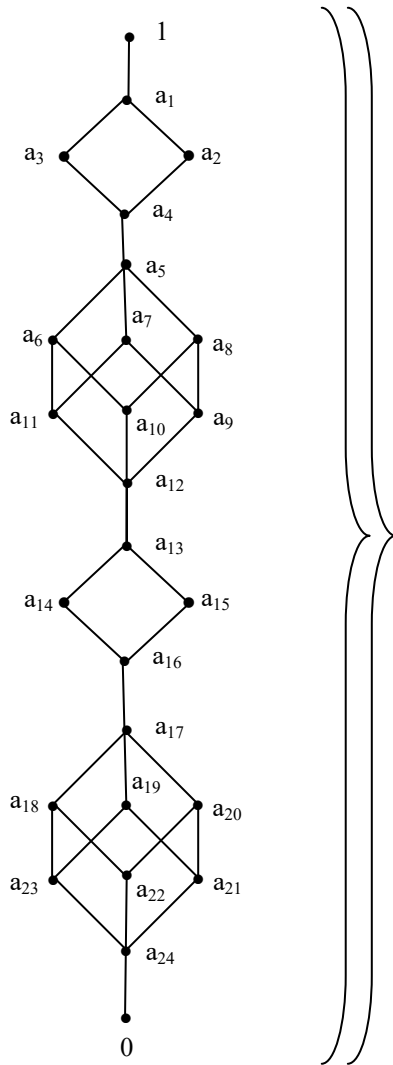

be the subset semiring.

Study questions (i) and (iv) of problem 49 for this S.

53. Obtain some special and interesting features enjoyed by finite subset interval semirings of type II.
54. Does there exist subset interval semiring which has no subset zero divisors?
55. Can one prove all interval subset semirings will have subset zero divisors?
56. Prove the trees related with the finite set ideal subset semiring topological spaces  ${}_{P_i}T_o$ ,  ${}_{P_i}T_{\cup}^{\times}$ ,  ${}_{P_i}T_{\cap}^{\times}$ ,  ${}_{P_i}T_{\cup}^+$ ,  ${}_{P_i}T_{\cap}^+$  and  ${}_{P_i}T_S$  over the subsemiring (or subring) can find applications in data mining.
57. Find all the trees associated with the set ideal subsets semiring topological spaces subset semiring  $S = \{\text{Collection of all subsets from the ring } Z_5D_{2,7}\}$  over subrings of  $Z_5D_{2,7}$ .
58. Find all trees associated with the subset set ideal semiring topological spaces  ${}_{P_i}T_o$ ,  ${}_{P_i}T_{\cup}^{\times}$ ,  ${}_{P_i}T_{\cap}^{\times}$ ,  ${}_{P_i}T_{\cup}^+$ ,  ${}_{P_i}T_{\cap}^+$  and  ${}_{P_i}T_S$  over the subsemiring  $P_i$  of  $LS_3$  where  $L =$

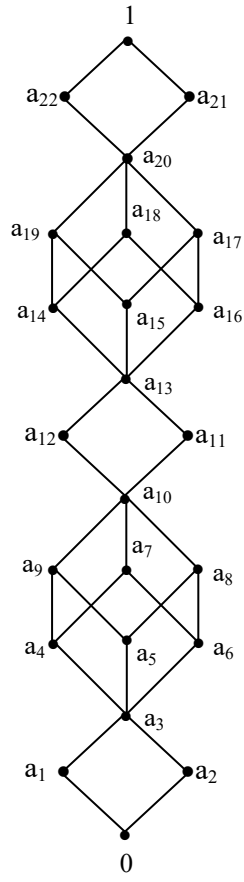

- 59. Find the basic sets of the spaces in problem 58.
- 60. Find the basic sets of the spaces in problem 57.
- 61. Let  $S = \{\text{Collection of all subsets from the semiring } Z_{12}D_{2,5}\}$  be the subset semiring of type I.

Find all subset set ideal semiring topological spaces of  $S$  over  $P_i$ , subring of  $Z_{12}D_{2,5}$  and find all the trees associated with them.

62. Let  $S = \{ \text{Collection of all subsets from the semiring } LS_3 \text{ where } L =$

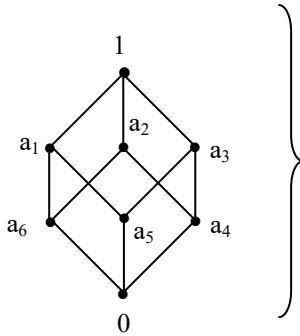

be the subset semiring of type II.

- (i) Find all subset set ideal semiring topological spaces of  $S$  over the subsemiring  $P_i$  of  $LS_3$  and their associated trees.
63. If  $L$  in problem 62  $LS_3$  is replaced by  $Z_8$  so that  $Z_8S_3$  is a ring find all subset set ideal semiring topological spaces of that  $S$  and the trees related with them.

Compare both the trees associated with the spaces in problem 62 and the spaces in problem 63.

## FURTHER READING

1. Birkhoff. G, *Lattice theory*, 2<sup>nd</sup> Edition, Amer-Math Soc. Providence RI 1948.
2. Birkhoff. G., and Maclane, S.S., *A Brief Survey of Modern Algebra*, New York, The Macmillan and Co. (1965).
3. Bruck, R.H., *A Survey of binary systems*, Berlin Springer Verlag, (1958).
4. Castillo, J., *The Smarandache Semigroup*, International Conference on Combinatorial Methods in Mathematics, II Meeting of the project 'Algebra, Geometria e Combinatoria', Faculdade de Ciencias da Universidade do Porto, Portugal, 9-11 July 1998.
5. Padilla, R., *Smarandache Algebraic Structures*, Smarandache Notions Journal, USA, Vol.9, No. 1-2, 36-38, (1998).
6. R.Lidl and G. Pilz, *Applied Abstract Algebra*, Springer Verlag, (1984).
7. Smarandache, Florentin, *Neutrosophic Logic, A Generalization of the Fuzzy Logic*,  
<http://gallup.unm.edu/~smarandache/NeutLog.txt>
8. Smarandache, Florentin, *Special Algebraic Structures, in Collected Papers III*, Abaddaba, Oradea, 78-81, 2000.
9. Sze Tsen Hu, *Elements of General Topology*, Holden Day Inc, 1970.
10. Vasantha Kandasamy, W.B., *Smarandache Rings*, American Research Press, Rehoboth, 2002.
11. Vasantha Kandasamy, W.B., *Smarandache Semigroups*, American Research Press, Rehoboth, 2002.

12. Vasantha Kandasamy, W.B., *Smarandache Semirings, Semifields and Semivector spaces*, American Research Press, Rehoboth, 2002.
13. Vasantha Kandasamy, W.B., and Smarandache, Florentin, *Fuzzy Interval Matrices, Neutrosophic Interval Matrices and their Applications*, Hexis, Phoenix, 2006.
14. Vasantha Kandasamy, W.B. and Florentin Smarandache, *Neutrosophic Rings*, Hexis, Arizona, 2006.
15. Vasantha Kandasamy, W.B. and Florentin Smarandache, *Set Linear Algebra and Set Fuzzy Linear Algebra*, InfoLearnQuest, Phoenix, 2008.
16. Vasantha Kandasamy, W.B. and Florentin Smarandache, *Finite Neutrosophic Complex Numbers*, Zip Publishing, Ohio, 2011.
17. Vasantha Kandasamy, W.B. and Florentin Smarandache, *Dual Numbers*, Zip Publishing, Ohio, 2012.
18. Vasantha Kandasamy, W.B. and Florentin Smarandache, *Natural Product  $\times_n$  on matrices*, Zip Publishing, Ohio, 2012.
19. Vasantha Kandasamy, W.B. and Florentin Smarandache, *Quasi Set Topological Vector Subspaces*, Educational Publisher Inc, Ohio, 2012.
20. Vasantha Kandasamy, W.B. and Florentin Smarandache, *Set Ideal Topological Spaces*, Zip Publishing, Ohio, 2012.
21. Vasantha Kandasamy, W.B. and Florentin Smarandache, *Special dual like numbers and lattices*, Zip Publishing, Ohio, 2012.
22. Vasantha Kandasamy, W.B. and Florentin Smarandache, *Algebraic Structures using Subsets*, Educational Publisher Inc, Ohio, 2013.
23. Vasantha Kandasamy, W.B. and Florentin Smarandache, *Subset Polynomial Semirings and Subset Matrix Semirings*, Educational Publisher Inc, Ohio, 2013.



# INDEX

## A

Annihilating subspaces, 107-9

## G

Group subset semigroup topological subspaces, 43-7

## N

Non commutative subset set ideal topological spaces of  
semigroups, 48-53

## S

Set ideal subset topological semiring spaces, 7-8

Smarandache subset semigroup topological spaces, 37-43

Special subset topological spaces, 7-11

Special type of topological spaces of a subset semigroup, 9-15

Standard (or usual) type of topological spaces of a subset  
semigroup, 9-12

Subset ring semiring topological spaces, 67-75

Subset semigroups, 7-9

Subset semiring of type I, 65-9

Subset semiring of type II, 95-9

Subset semiring ring topological subspaces, 80-9

Subset semiring topological spaces of type II, 96-9

Subset semirings, 7-12

Subset set ideal semiring topological spaces over subsemirings,  
159-68

Subset set ideal semiring topological spaces, 159-78

Subset subsemiring topological spaces, 116-9

Subset topological zero divisors, 12-4

## ABOUT THE AUTHORS

**Dr.W.B.Vasantha Kandasamy** is a Professor in the Department of Mathematics, Indian Institute of Technology Madras, Chennai. In the past decade she has guided 13 Ph.D. scholars in the different fields of non-associative algebras, algebraic coding theory, transportation theory, fuzzy groups, and applications of fuzzy theory of the problems faced in chemical industries and cement industries. She has to her credit 646 research papers. She has guided over 100 M.Sc. and M.Tech. projects. She has worked in collaboration projects with the Indian Space Research Organization and with the Tamil Nadu State AIDS Control Society. She is presently working on a research project funded by the Board of Research in Nuclear Sciences, Government of India. This is her 88<sup>th</sup> book.

On India's 60th Independence Day, Dr.Vasantha was conferred the Kalpana Chawla Award for Courage and Daring Enterprise by the State Government of Tamil Nadu in recognition of her sustained fight for social justice in the Indian Institute of Technology (IIT) Madras and for her contribution to mathematics. The award, instituted in the memory of Indian-American astronaut Kalpana Chawla who died aboard Space Shuttle Columbia, carried a cash prize of five lakh rupees (the highest prize-money for any Indian award) and a gold medal.

She can be contacted at [vasanthakandasamy@gmail.com](mailto:vasanthakandasamy@gmail.com)

Web Site: [http://mat.iitm.ac.in/home/wbv/public\\_html/](http://mat.iitm.ac.in/home/wbv/public_html/)

or <http://www.vasantha.in>

---

**Dr. Florentin Smarandache** is a Professor of Mathematics at the University of New Mexico in USA. He published over 75 books and 200 articles and notes in mathematics, physics, philosophy, psychology, rebus, literature. In mathematics his research is in number theory, non-Euclidean geometry, synthetic geometry, algebraic structures, statistics, neutrosophic logic and set (generalizations of fuzzy logic and set respectively), neutrosophic probability (generalization of classical and imprecise probability). Also, small contributions to nuclear and particle physics, information fusion, neutrosophy (a generalization of dialectics), law of sensations and stimuli, etc. He got the 2010 Telesio-Galilei Academy of Science Gold Medal, Adjunct Professor (equivalent to Doctor Honoris Causa) of Beijing Jiaotong University in 2011, and 2011 Romanian Academy Award for Technical Science (the highest in the country). Dr. W. B. Vasantha Kandasamy and Dr. Florentin Smarandache got the 2012 New Mexico-Arizona and 2011 New Mexico Book Award for Algebraic Structures. He can be contacted at [smarand@unm.edu](mailto:smarand@unm.edu)

**Special type of subset topological spaces introduced by the authors pave way for topological spaces which basically inherit the algebraic structure from which the subsets are taken. This study is new and happens to be a mixture of algebra and topology.**

US \$35.00

**Educational  
Publisher Inc.**

ISBN 9781599732435



9 781599 732435

90000 >

