



11-27-2012

## Compression Transmission Collar for Fastening

David LeCronier

Patrick Atkinson  
patkinso@kettering.edu

Follow this and additional works at: [https://digitalcommons.kettering.edu/mech\\_eng\\_patents](https://digitalcommons.kettering.edu/mech_eng_patents)



Part of the [Mechanical Engineering Commons](#)

---

### Recommended Citation

LeCronier, David and Atkinson, Patrick, "Compression Transmission Collar for Fastening" (2012).  
*Mechanical Engineering Patents*. 22.  
[https://digitalcommons.kettering.edu/mech\\_eng\\_patents/22](https://digitalcommons.kettering.edu/mech_eng_patents/22)

This Patent is brought to you for free and open access by the Mechanical Engineering at Digital Commons @ Kettering University. It has been accepted for inclusion in Mechanical Engineering Patents by an authorized administrator of Digital Commons @ Kettering University. For more information, please contact [digitalcommons@kettering.edu](mailto:digitalcommons@kettering.edu).



US008317789B2

(12) **United States Patent**  
**LeCronier et al.**

(10) **Patent No.:** **US 8,317,789 B2**  
(45) **Date of Patent:** **Nov. 27, 2012**

(54) **COMPRESSION TRANSMISSION COLLAR FOR FASTENING**

1,709,933 A 11/1928 Loutrel  
1,691,444 A 4/1929 Cowan  
5,433,567 A 7/1995 Ito  
7,695,226 B2 4/2010 March et al.  
2004/0147930 A1 7/2004 Zander

(75) Inventors: **David LeCronier**, Oxford, MI (US);  
**Patrick Atkinson**, Grand Blanc, MI (US)

FOREIGN PATENT DOCUMENTS

(73) Assignee: **Kettering University**, Flint, MI (US)

GB 1337688 A 11/1973

(\*) Notice: Subject to any disclaimer, the term of this patent is extended or adjusted under 35 U.S.C. 154(b) by 68 days.

OTHER PUBLICATIONS

International Search Report dated Jan. 19, 2012, 4 pages.

(21) Appl. No.: **12/901,728**

Primary Examiner — Ellen C Hammond

(22) Filed: **Oct. 11, 2010**

(74) Attorney, Agent, or Firm — Dickinson Wright, PLLC

(65) **Prior Publication Data**

US 2012/0089175 A1 Apr. 12, 2012

(57) **ABSTRACT**

(51) **Int. Cl.**  
**A61B 17/72** (2006.01)

A compression transmission collar apparatus (20) for implantation into a bone (22) with a hole (28) having a hole wall (32) comprising an intramedullary nail (34) defining a bore (40) and a threaded fastener (42) and a compression transmission collar (58) including an exterior face (64) and a top edge (60) and a bottom edge (62) and a first end (70) intersecting the top edge (60) at an acute angle ( $\alpha_1$ ) and the bottom edge (62) at an obtuse angle ( $\alpha_2$ ) and a second end (72) intersecting the top edge (60) at an obtuse angle ( $\alpha_2$ ) and the bottom edge (62) at an acute angle ( $\alpha_1$ ) and the first end (70) partially overlapping and opposing the second end (72) to define a slit (74) such that applying a compressional load to the top edge (60) causes the first end (70) to slide relative to and along the second end (72) causing the compression transmission collar (58) to compress axially and expand radially pressing the exterior face (64) against the hole wall (32).

(52) **U.S. Cl.** ..... **606/64**

(58) **Field of Classification Search** ..... 606/60,  
606/62-68, 105

See application file for complete search history.

(56) **References Cited**

U.S. PATENT DOCUMENTS

859,054 A 7/1907 Fischer  
903,109 A 11/1908 Ross  
1,655,018 A 1/1928 Loutrel

**9 Claims, 7 Drawing Sheets**

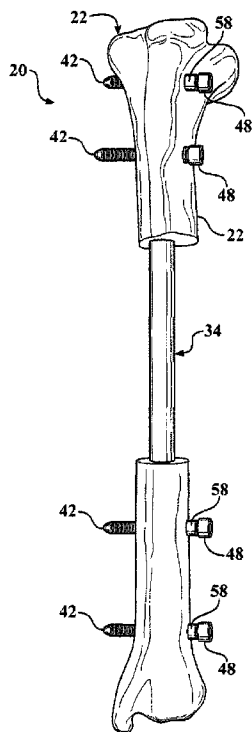

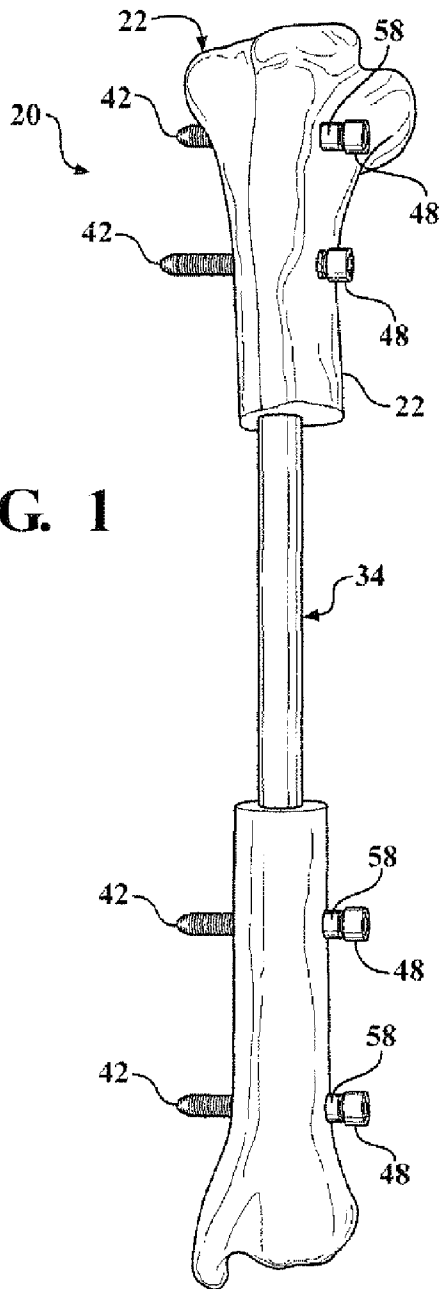

FIG. 1

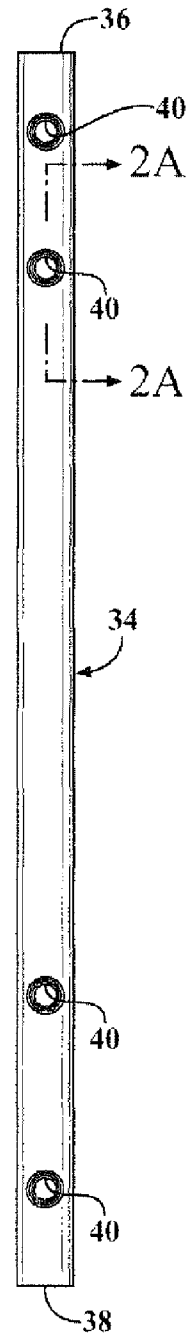

FIG. 2

FIG. 2A

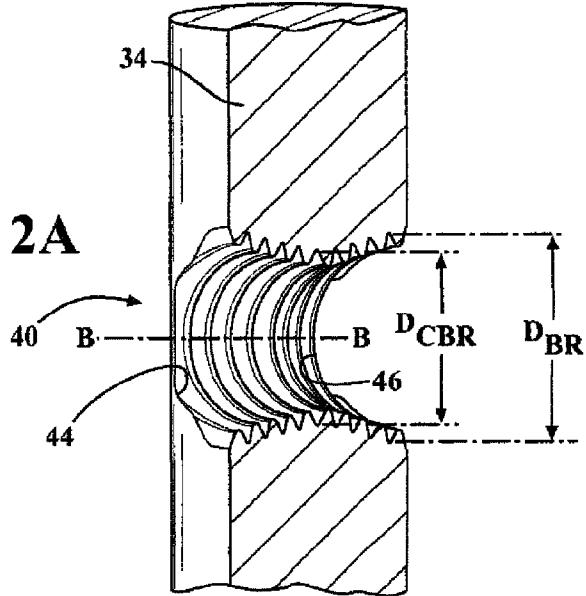

FIG. 3

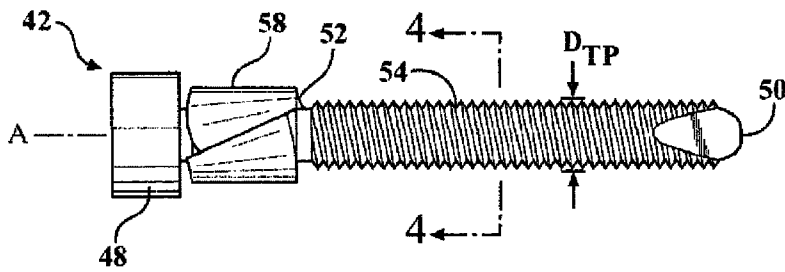
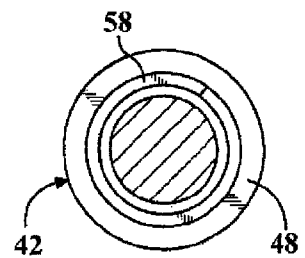

FIG. 4







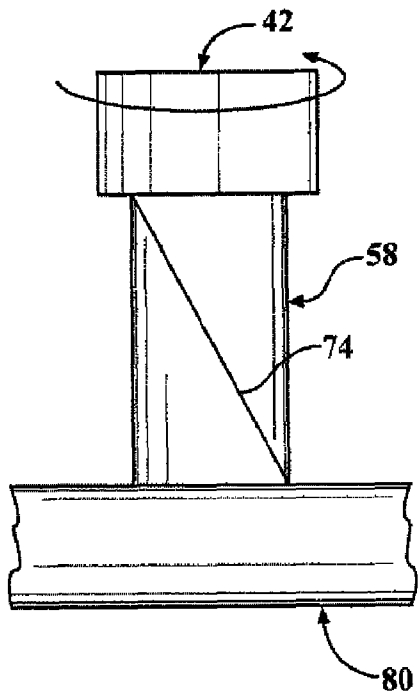

FIG. 9A

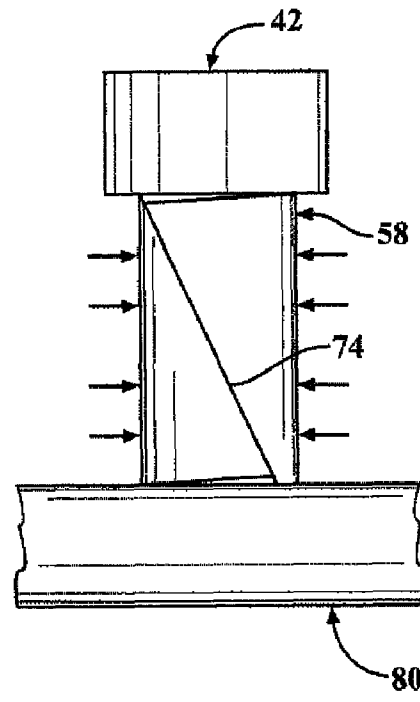

FIG. 9B

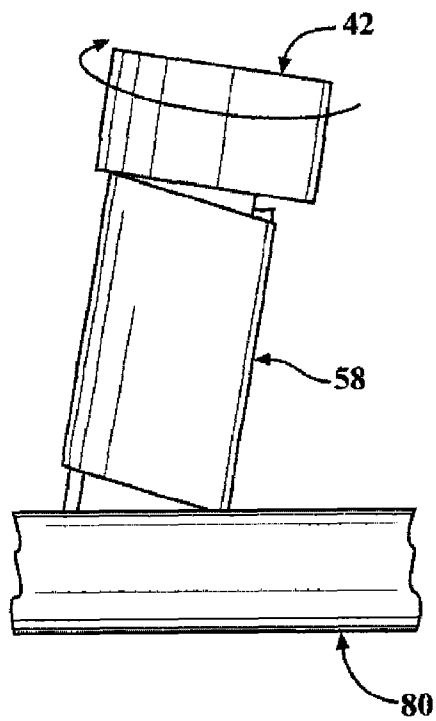

FIG. 10A

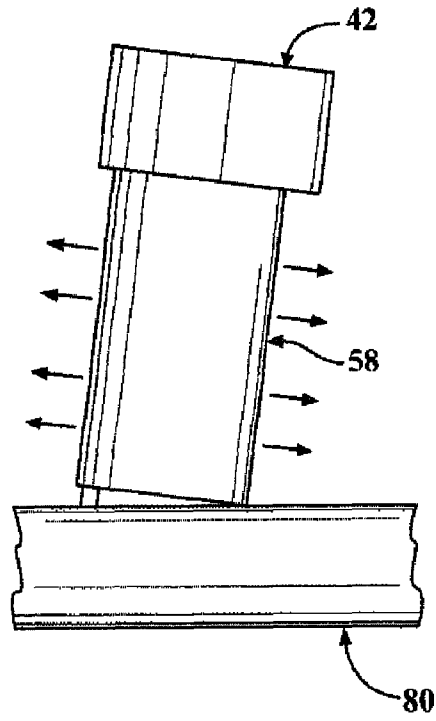

FIG. 10B

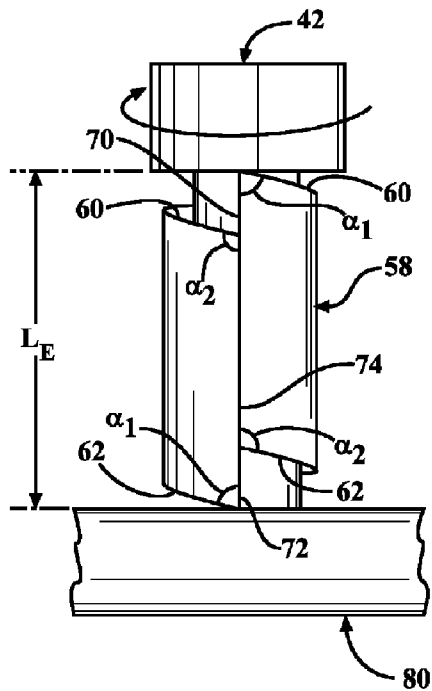

FIG. 11A

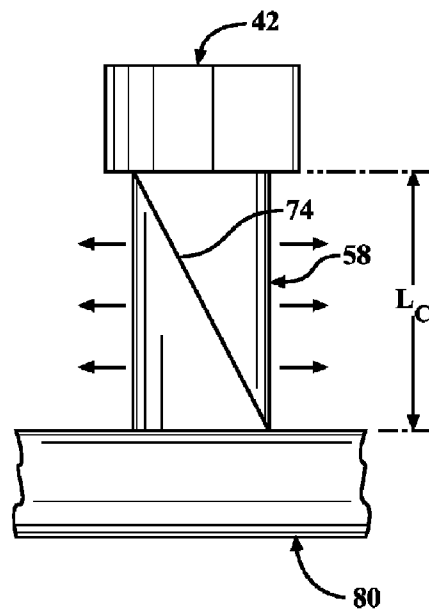

FIG. 11B

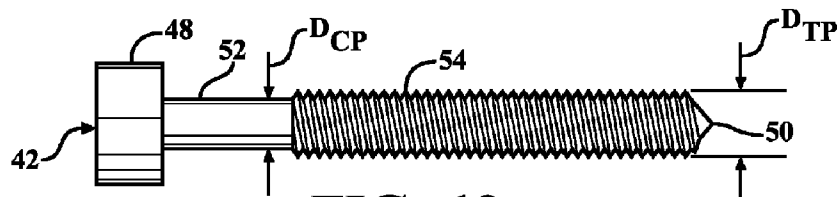

FIG. 12

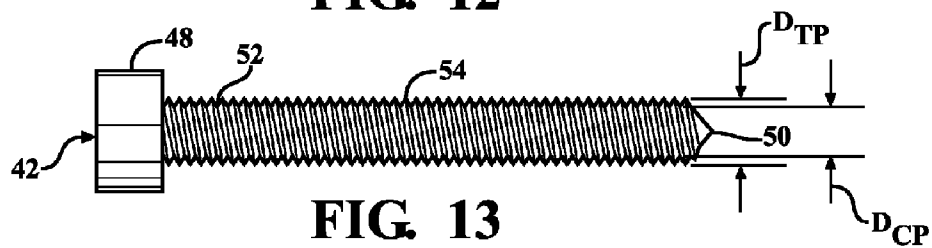

FIG. 13

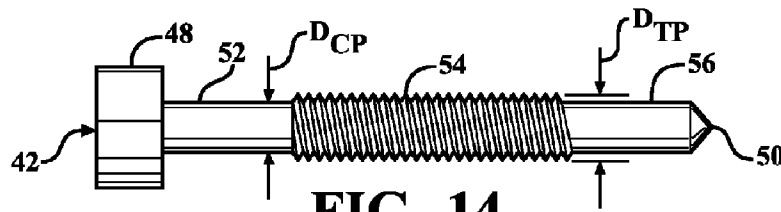

FIG. 14



FIG. 15A

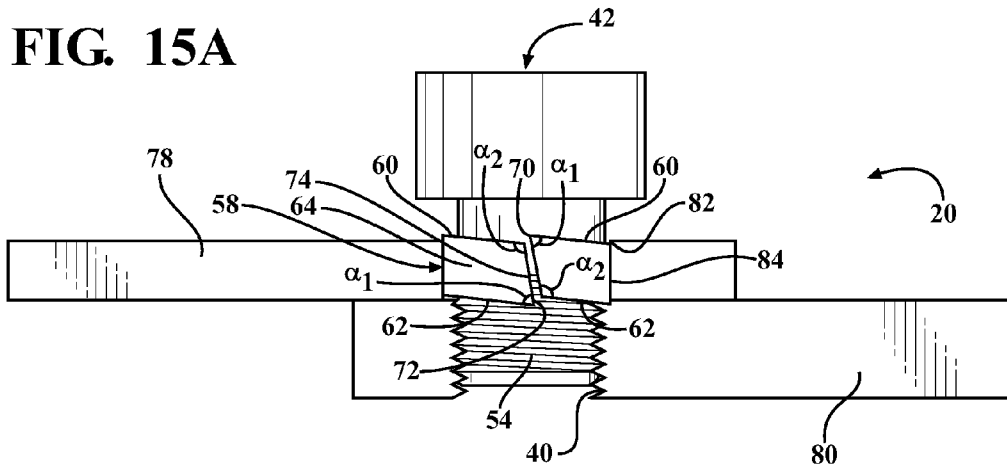

FIG. 15B

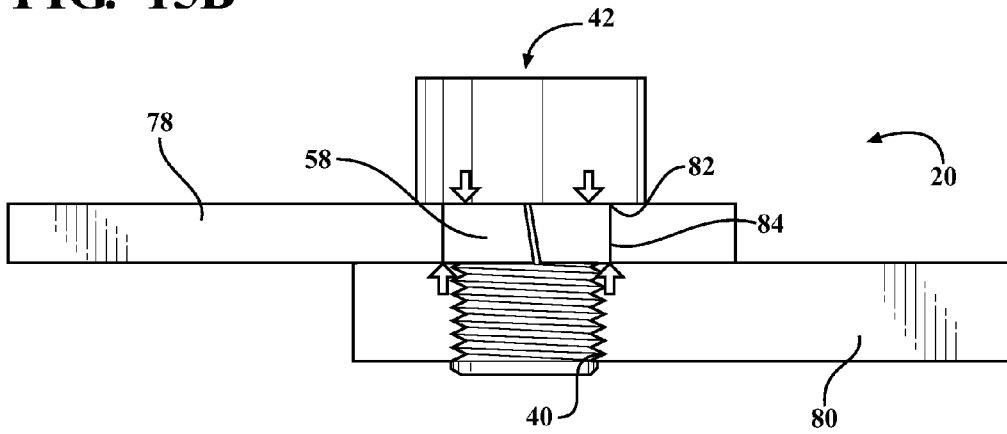
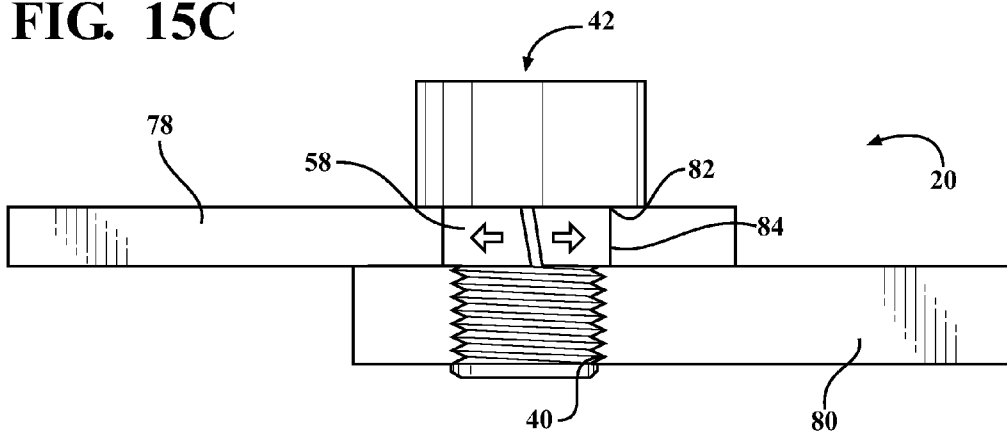

FIG. 15C



## COMPRESSION TRANSMISSION COLLAR FOR FASTENING

### STATEMENT REGARDING FEDERALLY SPONSORED RESEARCH

This invention was made with Government support under contract numbers W81XWH0720119 and W81XWH1120128 awarded by the United States Army Medical Research Acquisition Activity. The Government has certain rights in this invention.

### BACKGROUND OF THE INVENTION

#### 1. Field of the Invention

The subject invention generally relates to a compression transmission collar apparatus for fastening two members. The subject invention is specifically applicable to a compression transmission collar apparatus that is implantable into bone for use in treating bone fractures by skeletal fixation medical procedures.

#### 2. Description of the Prior Art

Skeletal fixation is a well known type of medical procedure for treating bone fractures. The skeletal fixation procedures known in the art typically call for the use of fasteners to fixate, or fasten, the ends of the fractured bone to one another. Accordingly, the fasteners and other related hardware used in typical skeletal fixation procedures are analogous to the fasteners and other related hardware used in other applications such as carpentry, construction, and assembly.

U.S. Patent Application No. 12/818,395 to LeCronier et al. teaches an easily implantable and stable nail-fastener apparatus for skeletal fixation including an intramedullary nail for insertion into the medullary canal of a bone. The intramedullary nail defines a threaded bore extending transverse to the intramedullary nail. A threaded fastener including a threaded portion extending transversely to the intramedullary nail threadedly engages the bore of the intramedullary nail. A compression transmission collar of annular shape having an exterior face and a top edge is provided for receiving a compressional load from the threaded fastener and transmitting the compressional load to the intramedullary nail. When simplified to the more general field of fasteners, the bone essentially comprises a first member defining a hole having a hole wall and the intramedullary nail comprises a second member defining a threaded bore. A threaded fastener then is provided to threadedly engage the bore and fixate the first member to the second member. Lastly, a compression transmission collar of annular shape is provided to transmit the compressional load of the fastener to at least one of the fastened members.

One compression transmission collar well known in the art of fasteners and related hardware is the helical lock washer. Expired U.S. Pat. No. 1,655,018 to Loutrel teaches a compression spring washer for use with fasteners. The Loutrel design discloses a helical shaped washer having a top edge and a bottom edge and a first end and a second end defining a slit. The top edge is designed to contact the threaded fastener for receiving a compressional load from the threaded fastener and the bottom edge is design to contact and transmit the compressional load to one of the fastened members. Finally, due to the helical shape of the Loutrel design, the compression spring washer has an extended length and a compressed length.

A problem with the compression transmission collars known in the art, such as the helical lock washer, is that the compressional load received by the compression transmission collar is transmitted axially to the surface of the fastened

member surrounding the hole or the bore. Axial transmission of the compressional load in close proximity to the hole or bore is particularly problematic where at least one of the fastened members is a brittle or easily deformable material. In such cases, the axial transmission of the compressional load can easily cause the material to break, crack, or deform because it has already been weakened by the presence of the hole or bore. This problem is especially significant in skeletal fixation procedures because they involve the repair of an already fractured bone which is a brittle material. Accordingly, there remains a need for a compression transmission collar that provides for the fastening of two members but does not transmit a compressional load to one of the fastened members in the axial direction.

### SUMMARY OF THE INVENTION

The subject invention provides for a compression transmission collar including an exterior face having an exterior diameter providing at least partial insertion of the compression transmission collar into the hole of the first member. The bottom edge of the compression transmission collar contacts the second member for transmitting the compressional load to the second member. The first end of the compression transmission collar intersects the top edge at an acute angle and the bottom edge at an obtuse angle. The second end of the compression transmission collar intersects the top edge at an obtuse angle and the bottom edge at an acute angle. Accordingly, the first end at least partially overlaps and opposes the second end to define the slit in the compression transmission collar. In response to the application of a compressional load to the top edge of the compression transmission collar, the first end slides relative to and along the second end causing the compression transmission collar to expand radially and compress axially between the extended length and the compressed length. The radial expansion of the compression transmission collar presses the exterior face of the compression transmission collar against the hole wall of the first member to securely fasten the first member to the threaded fastener and the second member.

By providing a compression transmission collar that expands in response to the application of a compressional load, the subject invention solves the problem associated with using fasteners that apply a compressional load in the axial direction in close proximity to a hole or bore in applications where at least one of the fastened members is of a brittle or easily deformable material. The expansion of the compression transmission collar allows for the fastening of the members without applying a compressional load to the first member and thereby avoids the risk of breaking, cracking, or deforming the first member. Accordingly, the subject invention is particularly useful in applications where at least the first member is of a brittle or easily deformable material such as glass, ceramic, rubber, polymers, and crystalline materials. Given the brittle characteristics of bone, the subject invention is especially useful in the field of skeletal fixation where preserving the integrity of the fastened members is vital for successful treatment of a fractured bone.

### BRIEF DESCRIPTION OF THE DRAWINGS

Other advantages of the present invention will be readily appreciated, as the same becomes better understood by reference to the following detailed description when considered in connection with the accompanying drawings wherein:

FIG. 1 is a side perspective view of the complete compression transmission collar apparatus implanted in the bone;

3

FIG. 2 is a front view of the intramedullary nail;

FIG. 2A is an enlarged perspective view taken along line 2A-2A of FIG. 2 illustrating the bore of the intramedullary nail;

FIG. 3 is a side view of the threaded fastener and the compression transmission collar;

FIG. 4 is an enlarged cross-sectional view taken along line 4-4 of FIG. 3 illustrating the threaded fastener and the compression transmission collar;

FIG. 5 is an enlarged horizontal fragmentary cross-sectional view of a portion of FIG. 1 illustrating the compression transmission collar apparatus wherein the threaded fastener is installed parallel to the bore axis;

FIG. 6 is an enlarged horizontal fragmentary cross-sectional view of a portion of FIG. 1 illustrating the compression transmission collar apparatus wherein the threaded fastener is installed at an oblique angle relative to the bore axis;

FIG. 7A is a side view of a first embodiment of the compression transmission collar wherein the slit is further defined by a gap having a gap distance equal to zero;

FIG. 7B is an end view of the compression transmission collar of FIG. 7A;

FIG. 8A is a side view of a second embodiment of the compression transmission collar wherein the slit is further defined by a gap having a gap distance greater than zero;

FIG. 8B is an enlarged fragmentary view of a portion of FIG. 8A illustrating the gap of the compression transmission collar;

FIG. 9A is a side view of the threaded fastener, a portion of the second member, and the compression transmission collar in an axially compressed state;

FIG. 9B is a side view of the threaded fastener, a portion of the second member, and the compression transmission collar in an axially extended state wherein the radial contraction of the compression transmission collar is shown;

FIG. 10A is a side view of the threaded fastener, a portion of the second member, and the compression transmission collar in an axially extended state wherein the threaded fastener is installed at an oblique angle to the second member;

FIG. 10B is a side view of the threaded fastener, a portion of the second member, and the compression transmission collar in an axially compressed state wherein the threaded fastener is installed at an oblique angle to the second member and the radial expansion of the compression transmission collar is shown;

FIG. 11A is a side view of the threaded fastener, a portion of the second member, and the compression transmission collar in an axially extended state wherein the threaded fastener is installed at a perpendicular angle to the second member;

FIG. 11B is a side view of the threaded fastener, a portion of the second member, and the compression transmission collar in an axially compressed state wherein the threaded fastener is installed at a perpendicular angle to the second member and the radial expansion of the compression transmission collar is shown;

FIG. 12 is a side view of a threaded fastener including a threaded portion adjacent a compression portion being unthreaded;

FIG. 13 is a side view of a threaded fastener including a threaded portion adjacent a compression portion being threaded;

FIG. 14 is a side view of a threaded fastener including a threaded portion disposed between a compression portion being unthreaded and an unthreaded portion adjacent the end;

FIG. 15A is a side view looking transparently through the first member and the second member showing the installation

4

of the threaded fastener and the compression transmission collar wherein the threaded fastener is engaging the bore of the second member and the compression transmission member is still in an axially extended state;

FIG. 15B is a side view looking transparently through the first member and the second member showing the installation of the threaded fastener and the compression transmission collar wherein the threaded fastener is applying a compressional load to the top edge of the compression transmission collar and the compression transmission collar is compressing axially and expanding radially; and

FIG. 15C is a side view looking transparently through the first member and the second member showing the installation of the threaded fastener and the compression transmission collar wherein the compression transmission collar is in an axially compressed state and has expanded radially so that the exterior face of the compression transmission collar is pressed against the hole wall of the first member.

#### DETAILED DESCRIPTION OF THE ENABLING EMBODIMENTS

Referring to the Figures, wherein like numerals indicate corresponding parts throughout the several views, a compression transmission collar apparatus 20 is generally shown for implantation into a bone 22 during a skeletal fixation medical procedure. The bone 22 includes a medullary canal 24 surrounded by cortex 26. The bone 22 also includes a near cortex hole 28 and a far cortex hole 30 located in the cortex 26. The near cortex hole 28 has a near cortex hole diameter ( $D_{NC}$ ) and a near cortex hole wall 32. The far cortex hole 30 has a far cortex hole diameter ( $D_{FC}$ ). The near cortex hole 28 and the far cortex hole 30 are positioned on opposing sides of the medullary canal 24 with the near cortex hole diameter ( $D_{NC}$ ) being greater than the far cortex hole diameter ( $D_{FC}$ ) although the present invention is not limited to this configuration. It is envisioned that the compression transmission collar apparatus 20 of the present invention may be used in a configuration lacking a far cortex hole 30 altogether.

The compression transmission collar apparatus 20 further includes an intramedullary nail 34 for insertion into the medullary canal 24 of the bone 22. The intramedullary nail 34 extends between a top end 36 and a bottom end 38. The intramedullary nail 34 defines a bore 40 extending transverse to the intramedullary nail 34 for receiving a threaded fastener 42. Accordingly, the bore 40 may extend at a right angle or an oblique angle to the intramedullary nail 34. The bore 40 is threaded and has a bore axis (B) extending between a near opening 44 and a far opening 46 transverse to the intramedullary nail 34. The bore 40 also has a bore diameter ( $D_{BR}$ ) including a central bore diameter ( $D_{CBR}$ ) equal in diameter to the far cortex hole diameter ( $D_{FC}$ ). The central bore diameter ( $D_{CBR}$ ) is disposed centrally between the near opening 44 and the far opening 46 of the bore 40. As shown in FIG. 2A, the bore diameter ( $D_{BR}$ ) increases from the central bore diameter ( $D_{CBR}$ ) to the near opening 44 and from the central bore diameter ( $D_{CBR}$ ) to the far opening 46. Accordingly, the bore 40 defined by the intramedullary nail 34 has a hyperboloid shape although a traditional cylindrically shaped bore 40 could alternatively be used. However, as shown in FIG. 6, the hyperboloid shape of the bore 40 is advantageous because it allows the threaded fastener 42 to be mounted at a variety of angles in relation to the bore axis (B). This advantage is especially important during skeletal fixation medical procedures because doctors often do not have the ability or time to assure perpendicular mounting.

5

The threaded fastener **42** extends along a fastener axis (A) between a head **48** and an end **50**. The threaded fastener **42** further includes a compression portion **52** and a threaded portion **54** and an unthreaded portion **56** adjacent to the end **50**. The compression portion **52** does not engage the threads of the bore **40** and so the compression portion **52** may be threaded or unthreaded. The compression portion **52** has a compression portion diameter ( $D_{CP}$ ) that is smaller than or equal to the threaded portion diameter ( $D_{TP}$ ). The threaded portion **54** has a threaded portion diameter ( $D_{TP}$ ) that is equal to the central bore diameter ( $D_{CBR}$ ). Where the configuration includes a far cortex hole **30**, the far cortex hole diameter ( $D_{FC}$ ) may be equal to the central bore diameter ( $D_{CBR}$ ) and the threaded portion diameter ( $D_{TP}$ ). The use of a threaded fastener **42** including only a threaded portion **54** running from the head **48** to the end **50** is also contemplated by the present invention. The threaded fastener **42** extends through the intramedullary nail **34** and the far cortex hole **30** so as to extend transversely to the intramedullary nail **34** for threadedly engaging the bore **40**. In a configuration absent the far cortex hole **30**, the fastener extends only through the intramedullary nail **34**. By threadedly engaging the bore **40**, the threaded fastener **42** applies a compressional load to the intramedullary nail **34** and fixates the intramedullary nail **34** within the medullary canal **24** of the bone **22**.

The compression transmission collar apparatus **20** further includes a compression transmission collar **58** of annular shape having a top edge **60** and a bottom edge **62**. The top edge **60** contacts the head **48** of the threaded fastener **42** for receiving the compressional load from the threaded fastener **42**. The bottom edge **62** contacts the intramedullary nail **34** for transmitting the compressional load to the intramedullary nail **34**. The compression transmission collar **58** also has an exterior face **64** having an exterior diameter ( $D_E$ ) and an interior face **66** having an interior diameter ( $D_I$ ). The interior diameter ( $D_I$ ) is greater than the compression portion diameter ( $D_{CP}$ ) of the fastener. The interior face **66** of the compression transmission collar **58** defines an interior space **68** for providing space at least partially about the threaded fastener **42** for allowing the fastener axis (A) to be variously disposed relative to the interior space **68**. Accordingly, the compression transmission collar **58** transmits the compressional load of the threaded fastener **42** to the intramedullary nail **34** during fixation.

The compression transmission collar **58** further includes a first end **70** and a second end **72**. As shown in FIG. **8A**, **11A**, and **15A**, the first end **70** intersects the top edge **60** at an acute angle  $\alpha_1$  and the bottom edge **62** at an obtuse angle  $\alpha_2$ . The second end **72** intersects the top edge **60** at an obtuse angle  $\alpha_2$  and the bottom edge **62** at an acute angle  $\alpha_1$ . The first end **70** partially overlaps and opposes the second end **72** to define a slit **74** such that applying the compressional load to the top edge **60** causes the first end **70** to slide relative to and along the second end **72**. Accordingly, the application of the compressional load to the top edge **60** of the compression transmission collar **58** causes the compression transmission collar **58** to compress axially between the extended length ( $L_E$ ) and the compressed length ( $L_C$ ). The axial compression of the compression transmission collar **58** corresponds to a radial expansion of the compression transmission collar **58**. In other words, as the compression transmission collar **58** is axially compressed, the circumference of the compression transmission collar **58** increases. Thus, the exterior face **64** of the compression transmission collar **58** is pressed against the near cortex hole wall **32** in response to the radial expansion of the compression transmission collar **58** caused by the application of the compressional load. The pressure exerted by the

6

exterior face **64** of the compression transmission collar **58** against the near cortex hole wall **32** fastens the threaded fastener **42** and the intramedullary nail **34** to the bone **22** and prevents movement of the compression transmission collar **58** relative to the near cortex hole **28**.

The compression transmission collar **58** is made of a resilient material so that the compression transmission collar **58** expands axially and contracts radially in response to removal of the compressional load. The resilient material may be but is not limited to a metal, a metal alloy, a rubber, or a polymer. Obviously, other materials may be employed and their use is envisioned by the present invention.

As shown in FIGS. **7A** and **8A**, in one embodiment of the present invention, the compression transmission collar **58** extends in a helical path between the first end **70** and the second end **72** when the compression transmission collar **58** is at the extended length ( $L_E$ ). The present invention is not limited to this embodiment as the use of a compression transmission collar **58** that does not extend in a helical path between the first end **70** and the second end **72** is also envisioned. Also shown in FIGS. **7A** and **8A**, the exterior face **64** of the compression transmission collar **58** is generally trapezoidal in shape. The present invention alternatively envisions use of a compression transmission collar **58** including an exterior face **64** having a non-trapezoidal shape.

The slit **74** in the compression transmission collar **58** is further defined by a gap **76** having a gap distance ( $L_G$ ). The gap distance ( $L_G$ ) equals the tangential distance between the first end **70** and the second end **72**. In one embodiment of the present invention, as shown in FIG. **8A**, the gap distance ( $L_G$ ) is greater than zero when the compression transmission collar **58** is at the extended length ( $L_E$ ). In this embodiment, the first end **70** and the second end **72** close the gap **76** such that the gap distance ( $L_G$ ) becomes equal to zero in response to the application of the compressional load to the top edge **60** of the compression transmission collar **58**. Thus, in this embodiment, the first end **70** is spaced from the second end **72** by the gap **76** before the application of the compressional force and after the removal of the compressional force. In another embodiment of the present invention, as shown in FIG. **7A**, the slit **74** is further defined by a gap **76** having a gap distance ( $L_G$ ) equal to zero. In this embodiment, the first end **70** and the second end **72** remain in contact with one another before, during, and after the application of the compressional load.

The present invention also includes a method of skeletal fixation wherein the intramedullary nail **34** is fastened to the bone **22**. The method proceeds with the step of creating a bore **40** including threads in the intramedullary nail **34** extending transverse to the intramedullary nail **34** and inserting the intramedullary nail **34** into the medullary canal **24** of the bone **22**. The method further includes the steps of forming the near cortex hole **28** in the cortex **26** of the bone **22** in radially overlapping relationship to the bore **40** of the intramedullary nail **34** and similarly forming the far cortex hole **30** in the cortex **26** of the bone **22** in radially overlapping relationship to the bore **40** of the intramedullary nail **34**. The method also includes the steps of inserting the compression transmission collar **58** into the near cortex hole **28** and inserting the threaded fastener **42** through the compression transmission collar **58** and into the bore **40** of the intramedullary nail **34**. The method additionally includes the steps of applying torque to the head **48** of the threaded fastener **42** for threadedly engaging and advancing the threaded fastener **42** through the bore **40** of the intramedullary nail **34** and the far cortex hole **30** for applying compressional load to the top edge **60** of the compression transmission collar **58** to compress the compression transmission collar **58** axially between the extended

length ( $L_E$ ) and the compressed length ( $L_C$ ). The axial compression is accomplished by sliding the first end **70** of the compression transmission collar **58** relative to and along the second end **72** of the compression transmission collar **58** and results in the radial expansion of the compression transmission collar **58** within the near cortex hole **28**. The method proceeds with the step of removing torque from the head **48** of the threaded fastener **42** in response to compressing the compression transmission collar **58** to the compressed length ( $L_C$ ). A hard stop is felt by the operator in response to the compression transmission collar **58** reaching the compressed length ( $L_C$ ) to notify the operator to remove the torque from the head **48** of the threaded fastener **42**. The hard stop feature thus helps prevent the undertightening or overtightening of the threaded fastener **42**. This feature is especially advantageous during skeletal fixation medical procedures where time is limited and improper tightening cannot be easily corrected later because it quickly and positively notifies the doctor that he or she has properly installed and tightened the threaded fastener **42**.

The present invention also more generally relates to fastening structures for use outside of a skeletal fixation medical procedure. A compression transmission collar apparatus **20** for fastening two members **78, 80** is shown generally in FIGS. **15A-C**. The compression transmission collar apparatus **20** includes a first member **78** defining a hole **82** having a hole wall **84** and a second member **80** defining a bore **40** that is threaded. The compression transmission collar apparatus **20** further includes a compression transmission collar **58** of annular shape and a threaded fastener **42** having a threaded portion **54** for threadedly engaging the bore **40**. The compression transmission collar **58** has a top edge **60**, a bottom edge **62**, and an exterior face **64**. The top edge **60** contacts the threaded fastener **42** for receiving a compressional load from the threaded fastener **42**. The compression transmission collar **58** has an extended length ( $L_E$ ) and a compressed length ( $L_C$ ). The extended length ( $L_E$ ) equals the distance between the top edge **60** and the bottom edge **62** of the compression transmission collar **58** before the compressional force has been applied or after the compressional force has been removed. The compressed length ( $L_C$ ) equals the final or steady state distance between the top edge **60** and the bottom edge **62** of the compression transmission collar **58** after the compressional force has been applied but before the compressional force has been removed. The compression transmission collar **58** further includes a first end **70** and a second end **72** defining a slit **74**.

The exterior face **64** has an exterior diameter ( $D_E$ ) providing at least partial insertion of the compression transmission collar **58** into the hole **82** of the first member **78**. This allows the bottom edge **62** to contact the second member **80** for transmitting the compressional load to the second member **80**. The first end **70** intersects the top edge **60** at an acute angle  $\alpha_1$  and the bottom edge **62** at an obtuse angle  $\alpha_2$ . The second end **72** intersects the top edge **60** at an obtuse angle  $\alpha_2$  and the bottom edge **62** at an acute angle  $\alpha_1$ . The first end **70** at least partially overlaps and opposes the second end **72** to define the slit **74** such that applying the compressional load to the top edge **60** causes the first end **70** to slide relative to and along the second end **72**. Accordingly, the application of the compressional load to the top edge **60** of the compression transmission collar **58** causes the compression transmission collar **58** to compress axially between the extended length ( $L_E$ ) and the compressed length ( $L_C$ ). The axial compression of the compression transmission collar **58** corresponds to a radial expansion of the compression transmission collar **58**. In other words, as the compression transmission collar **58** is axially

compressed, the circumference of the compression transmission collar **58** increases. Thus, the exterior face **64** of the compression transmission collar **58** is pressed against the hole wall **84** of the first member **78** in response to the radial expansion of the compression transmission collar **58** caused by the application of the compressional load. The pressure exerted by the exterior face **64** of the compression transmission collar **58** against the hole wall **84** acts to fasten the threaded fastener **42** and the second member **80** to the first member **78** and prevents movement of the compression transmission collar **58** relative to the hole **82** in the first member **78**.

Obviously, many modifications and variations of the present invention are possible in light of the above teachings and may be practiced otherwise than as specifically described while within the scope of the appended claims.

What is claimed is:

1. A compression transmission collar apparatus for implantation into a bone including the medullary canal surrounded by the cortex and a near cortex hole having a near cortex hole wall comprising:

an intramedullary nail for insertion into the medullary canal in the bone surrounded by the cortex, said intramedullary nail defining a bore extending transverse to said intramedullary nail and being threaded,

a threaded fastener including a threaded portion extending transversely to said intramedullary nail for threadedly engaging said bore,

a compression transmission collar of annular shape having an exterior face and a top edge for receiving a compressional load from said threaded fastener and a bottom edge for transmitting said compressional load to said intramedullary nail, and

said compression transmission collar having an extended length ( $L_E$ ) and a compressed length ( $L_C$ ) and including a first end intersecting said top edge at an acute angle and said bottom edge at an obtuse angle and a second end intersecting said top edge at an obtuse angle and said bottom edge at an acute angle and said first end partially overlapping and opposing said second end to define a slit such that applying said compressional load to said top edge causes said first end to slide relative to and along said second end causing said compression transmission collar to compress axially between said extended length ( $L_E$ ) and said compressed length ( $L_C$ ) and expand radially for pressing said exterior face against the near cortex hole wall to fasten the bone to said threaded fastener and said intramedullary nail.

2. An apparatus as set forth in claim 1 wherein said compression transmission collar extends in a helical path between said first end and said second end in said extended length ( $L_E$ ).

3. An apparatus as set forth in claim 1 wherein said compression transmission collar is of a resilient material for expanding axially and contracting radially in response to removing said compressional load from said top edge of said compression transmission collar.

4. An apparatus as set forth in claim 1 wherein said slit is further defined by a gap having a gap distance ( $L_G$ ) greater than zero and said first end and said second end close said gap with said gap distance ( $L_G$ ) equal to zero in response to applying said compressional load to said top edge of said compression transmission collar.

5. An apparatus as set forth in claim 1 wherein said slit is further defined by a gap having a gap distance ( $L_G$ ) equal to zero.

6. A compression transmission collar apparatus for implantation into a bone including the medullary canal surrounded

by the cortex and a near cortex hole having a near cortex hole diameter and a near cortex hole wall and a far cortex hole having a far cortex hole diameter ( $D_{FC}$ ) and with the near cortex hole diameter ( $D_{NC}$ ) being greater than the far cortex hole diameter ( $D_{FC}$ ) comprising;

an intramedullary nail for insertion into the medullary canal in the bone surrounded by the cortex, said intramedullary nail extending between a top end and a bottom end and defining a bore extending transverse to said intramedullary nail and being threaded and having a bore axis (B) extending between a near opening and a far opening transverse to said intramedullary nail and having a bore diameter ( $D_{BR}$ ) including a central bore diameter ( $D_{CBR}$ ) equal in diameter to the far cortex hole diameter ( $D_{FC}$ ) and being disposed centrally between said near opening and said far opening of said bore and increasing from said central bore diameter ( $D_{CBR}$ ) to said near opening and from said central bore diameter ( $D_{CBR}$ ) to said far opening,

a threaded fastener including a head and an end with a compression portion and a threaded portion and an unthreaded portion adjacent to said end extending along a fastener axis therebetween for extending through said intramedullary nail and the far cortex hole so as to extend transversely to said intramedullary nail for threadedly engaging said bore and applying a compressional load to said intramedullary nail for fixating said intramedullary nail within the medullary canal and said compression portion being unthreaded between said head and said threaded portion and having a compression portion diameter ( $D_{CP}$ ) and said threaded portion having a threaded portion diameter ( $D_{TP}$ ) larger than or equal to said compression portion diameter ( $D_{CP}$ ) and equal to the far cortex hole diameter ( $D_{FC}$ ) and said central bore diameter ( $D_{CBR}$ ) for extending through the near cortex hole and the far cortex hole with both holes radially overlapping said bore, and said threaded portion threadedly engaging said bore,

a compression transmission collar of annular shape having a top edge being in contact with said head of said threaded fastener for receiving said compressional load from said threaded fastener and a bottom edge being in contact with said intramedullary nail for transmitting said compressional load to said intramedullary nail and an exterior face having an exterior diameter ( $D_E$ ) and an interior face having an interior diameter ( $D_I$ ) being greater than said compression portion diameter ( $D_{CP}$ ) of said fastener and defining an interior space for providing space at least partially about said threaded fastener for allowing said fastener axis (A) to be variously disposed relative to said interior space for transmitting said compressional load of said threaded fastener to said intramedullary nail during fixation for contacting the near cortex hole to prevent movement of said compression transmission collar relative to the near cortex hole, and

said compression transmission collar having an extended length ( $L_E$ ) and a compressed length ( $L_C$ ) and a first end intersecting said top edge at an acute angle and said

bottom edge at an obtuse angle and a second end intersecting said top edge at an obtuse angle and said bottom edge at an acute angle and said first end partially overlapping and opposing said second end to define a slit such that applying said compressional load to said top edge causes said first end to slide relative to and along said second end causing said compression transmission collar to compress axially between said extended length ( $L_E$ ) and said compressed length ( $L_C$ ) and expand radially for pressing said exterior face against the near cortex hole wall to fasten the bone to said threaded fastener and said intramedullary nail, and

said compression transmission collar being of a resilient material for expanding axially and contracting radially in response to removing said compressional load, and said compression transmission collar extending in a helical path between said first end and said second end in said extended length ( $L_E$ ).

7. A compression transmission collar apparatus for fastening two members comprising;

a first member defining a hole having a hole wall, a second member defining a bore being threaded, a threaded fastener including a threaded portion for threadedly engaging said bore, and

a compression transmission collar of annular shape having a top edge being in contact with said threaded fastener for receiving a compressional load from said threaded fastener and a bottom edge and a first end and a second end defining a slit and an extended length ( $L_E$ ) and a compressed length ( $L_C$ ) and an exterior face,

said exterior face having an exterior diameter ( $D_E$ ) providing at least partial insertion of said compression transmission collar into said hole and said bottom edge being in contact with said second member for transmitting said compressional load to said second member and said first end intersecting said top edge at an acute angle and said bottom edge at an obtuse angle and said second end intersecting said top edge at an obtuse angle and said bottom edge at an acute angle and said first end at least partially overlapping and opposing said second end to define said slit such that applying said compressional load to said top edge causes said first end to slide relative to and along said second end causing said compression transmission collar to compress axially between said extended length ( $L_E$ ) and said compressed length ( $L_C$ ) and expand radially pressing said exterior face against said hole wall for fastening said first member to said threaded fastener and said second member.

8. A compression transmission collar apparatus as set forth in claim 7 wherein said slit of said compression transmission collar is the only slit in said compression transmission collar.

9. A compression transmission collar apparatus as set forth in claim 8 wherein said slit of said compression transmission collar extends continuously from said top edge to said bottom edge and said exterior diameter ( $D_E$ ) of said compression transmission collar is constant from said top edge to said bottom edge when said compression transmission collar is at said compressed length ( $L_C$ ).