

# Multi-loop Control Systems of Compensators for Powerful Sounding Pulses Generators

Elena Levon

Department of radioelectronics  
National Technical University "Kharkiv Polytechnic Institute"  
Kharkiv, Ukraine  
[elena\\_levon@ukr.net](mailto:elena_levon@ukr.net)

**Abstract**— Construction principles of multi-loop control systems of compensators for powerful sounding pulses generators are presented. A method for controlling a compensating system using fuzzy logic and forecast control ideas is described. Proposed compensating system is able to solve different problems: reactive power compensation, harmonic elimination. The system is based on a combination of a thyristor compensator and an active power filter. Some practical results with Matlab-Simulink are presented to check the proposed control performance.

**Keywords**— power electronics; reactive power control; active power filter; thyristor binary compensator; dynamic responses

## I. INTRODUCTION

System analysis of power quality supply, analysis and development of power theories, analysis of compensation systems of total power inactive components showed the construction possibility of multi-functional compensators of inactive components of total power, which are able to suppress high current harmonics that are consumed by load from power network; to compensate reactive component of network current fundamental harmonic; to symmetrize currents in phases of three-phase circuit; to suppress zero sequence currents. Such devices require the creation of effective construction principles of digital multi-loop control systems.

Currently two-channel compensator had been developed and it is based on the principle of a two-channel structure in the power circuit. The power circuit of the device is the compensated controlled rectifier that consists of the low and the high frequency channels. The power circuit is shown in [1, 6]. The control system of compensator is based on modern power theories, fuzzy logic and forecast control ideas. Control algorithms of dual channel compensator and control software in real time are considered in [2-5].

Fuzzy logic implementation is becoming increasingly important, and finds applications in diverse areas of current interest, such as control, pattern recognition, robotics, and other decision making applications. Fuzzy decision process offer a significant advantage over crisp decision process which is the ability to process different levels of truth instead of only 1 or 0 levels. Fuzzy logic does not require precise inputs, it is inherently robust, and can process any reasonable number of inputs but system complexity increases rapidly with more inputs and outputs. Distributed processors would probably be easier to implement. Simple, plain-language IF X AND Y

THEN Z rules are used to describe the desired system response in terms of linguistic variables rather than mathematical formulas. The number of rules is dependent on the number of inputs, outputs, and the designer's control response goals.

## II. COMPENSATORS CONTROL PRINCIPLES

Matlab-model of a two-channel semiconductor compensator with digital forecasted control system is shown in Fig. 1.

The model includes GTO bridge of the low frequency channel with load inductance, voltage inverter, capacity C with the diode group, fuzzy controller and the pulses distribution block. A load of compensator is the powerful sounding pulses generator, described in [5, 6].

The low frequency channel can be presented by two gating groups of lockable thyristors bridge and single-purpose thyristor bridge connected in parallel. The current flow through the reactor is provided by bridge on the lockable thyristors or on the single-purpose thyristor bridge. It depends on the sign of the reactive power on the compensator input. The proposed algorithm in [1, 2] assumes control of the reactive power sign and, when it changes, ensures current transfer from one to another rectifier.

A method for designing a fuzzy controller in the control system of compensation inactive components of the total power device is described in [3, 4]. Fuzzy controller implements a fuzzy inference procedure and makes it possible to obtain the required values of regulated and controlled process parameters, namely controls the amplitude level of selected mains current harmonic  $k_i$  and brings it to the required value. This can be achieved by varying the voltage on the capacitor of the inverter  $U_c$  by control signals  $U_{c\_ref}$  of additional output control circuit [3]. In the proposed control system based on fuzzy logic fuzzy controller input signals and output control actions are considered as linguistic variables, qualitatively characterized by the term-sets.

Each term is considered as a fuzzy set, and formalized using the membership function. Formation of the control action performed on the basis of linguistic control rules that establish means of natural language communication between the states of a dynamic system and manage the impact of the converter control system [2].

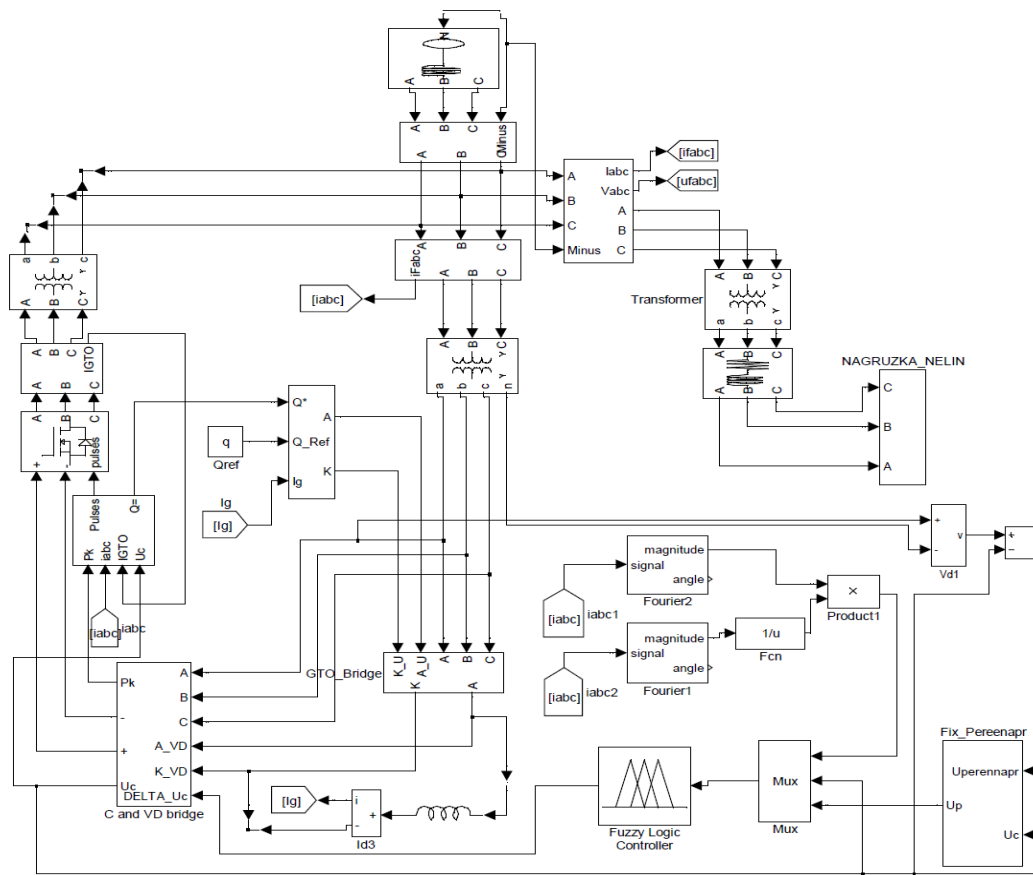

Fig. 1 Matlab-model of a two-channel semiconductor compensator

Hardware realization of fuzzy microcontroller fuzzy-controller can be done using special-purpose microcontrollers. As a special-purpose microcontroller with hardware support for fuzzy logic was selected microcontroller 68HC12 from Motorola.

The design process begins by associating fuzzy sets with the input and output variables. These fuzzy sets are described by type of membership functions. These fuzzy set values are labeled. The shape of the membership functions are, in general, trapezoids that may have no top (triangles) or may have no vertical sides. A functional diagram of a fuzzy-controller is shown in the following figure.

The fuzzy controller in Fig. 2 shown below consists of three parts: the fuzzification of inputs, the processing of rules, and the defuzzification of the output. The inputs to a fuzzy controller are assigned to the fuzzy variables with a degree of membership given by the membership functions. After applying all of the fuzzy rules to a given set of input variables, the output will belong to more than one fuzzy set with different weights.

The weighted output fuzzy sets are combined in a manner and described in [3] and then a centroid defuzzification process is used to obtain a single crisp output value.

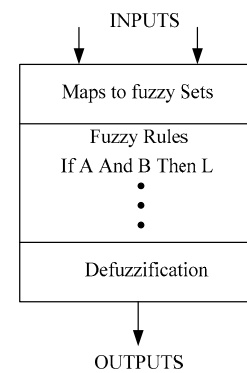

Fig. 2. Functional Diagram of a Fuzzy Controller

The system structure identifies the fuzzy logic inference flow from the input variables to the output variables. The fuzzification in the input interfaces translates analog inputs into fuzzy values. The fuzzy inference takes place in rule blocks which contain the linguistic control rules. The outputs of these rule blocks are linguistic variables. The defuzzification in the output interfaces translates them into analog variables.

III. SIMULATION RESULTS

The dependence of the amplitudes of the higher harmonics of the line current  $I_{Gi}$  and the level of voltage switching surges  $U_p$  on storage capacitor is shown in Fig. 3 [2].

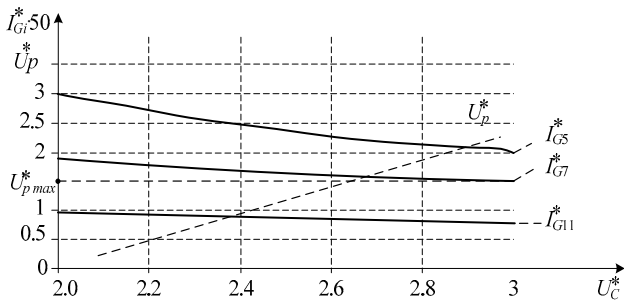

Fig. 3. The dependence of the amplitudes of the higher harmonics of the line current and the level of voltage switching surges on storage capacitor

Received dependences showed necessity for the regulator settings within a certain range. The regulator setting was carried out in Fuzzy Tech.

A structure of the fuzzy logic system in Fuzzy Tech is shown in Fig.4. The following figure shows the whole structure of this fuzzy system including input interfaces, rule blocks and output interfaces. The connecting lines symbolize the data flow. The appearance of interface Fuzzy Tech project in debug mode is shown in Fig. 5.

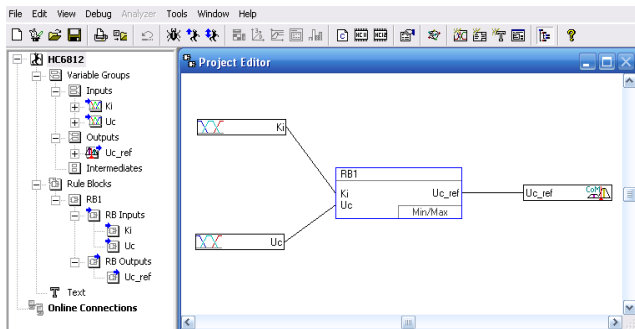

Fig. 4. Structure of the Fuzzy Logic System

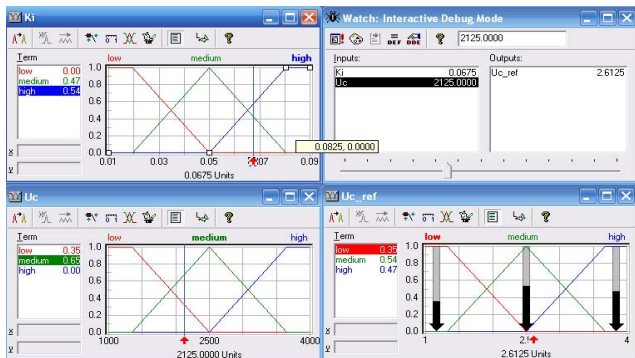

Fig. 5. The appearance of interface Fuzzy Tech project

View graphic table editor of fuzzy inference system is shown in Fig. 6. View of three-dimensional surface editor of fuzzy inference system is shown in Fig. 7.

#	IF	THEN	DoS	Uc_ref
1	low	low	1.00	medium
2	low	medium	1.00	low
3	low	high	1.00	high
4	medium	low	1.00	medium
5	medium	medium	1.00	high
6	medium	high	1.00	high
7	high	low	1.00	low
8	high	medium	1.00	medium
9	high	high	1.00	high
10				
11				
12				
13				

Fig. 6. Table editor window block rules Fuzzy Tech fuzzy inference system

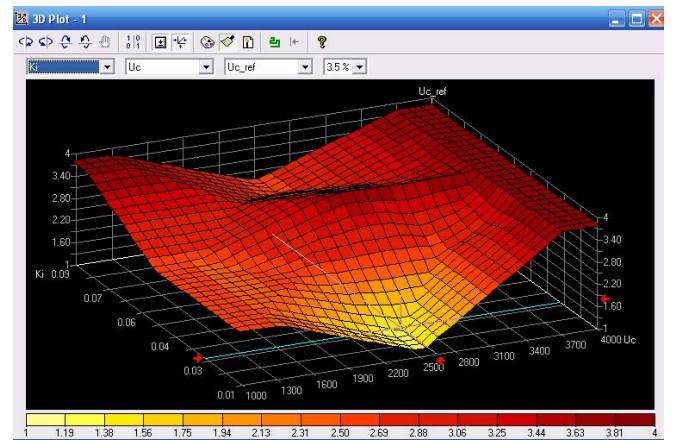

Fig. 7. View of three-dimensional surface editor of fuzzy inference system

Software implementation of fuzzy-control loop mains current harmonics in Assembler and C language is realized in [4]. Fuzzy Tech code editor is based on fuzzy logic microcontroller Motorola 68HC12. The 68HC12 is a high-speed, 16-bit processing unit that has a programming model identical to that of the industry standard M68HC11 CPU. The 68HC12 instruction set is a proper superset of the M68HC11 instruction set, and M68HC11 source code is accepted by 68HC12 assemblers with no changes. The 68HC12 has full 16-bit data paths and can perform arithmetic operations up to 20 bits wide for high-speed math. An instruction queue buffers program information so the CPU has immediate access to at least three bytes of machine code at the start of every instruction.

Energy characteristics of generator including reactive power  $Q$  and a power factor  $k$  when the compensator is connected are shown in Fig. 8.

Fig. 9 demonstrates changing of the current harmonics amplitudes  $I_m$  that are generated by the generator to the mains supply.

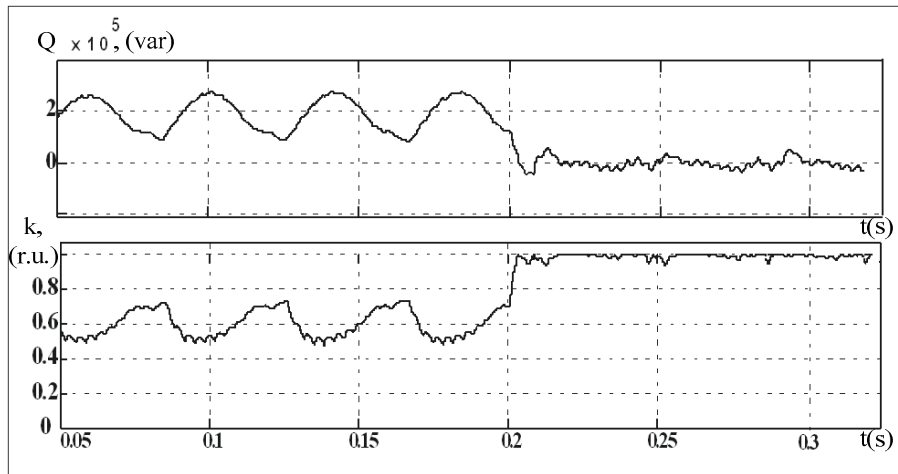

Fig. 8. Energy characteristics of generator

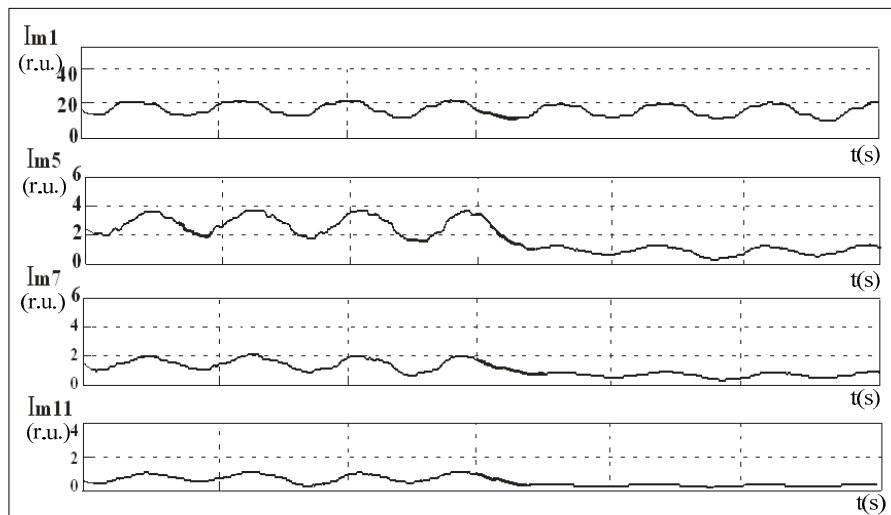

Fig. 9. Changing the current amplitudes of the harmonics generated by the generator to the mains supply

#### IV. CONCLUSION

The simulation results confirmed the effectiveness of the proposed multi-loop control system of compensators for powerful sounding pulses generators. Due to series of microcontrollers 68HC12, which has dedicated instructions for programming and implementation of fuzzy logic it has become easy to write a smaller code which can overcome the memory constraints of earlier versions of microcontrollers. The Fuzzy Tech design software has made it very easy to design a control system using fuzzy logic. This design approach using fuzzy logic is practically feasible and many other applications are open venues for further research and future work.

#### REFERENCES

- [1] I. F. Domnin, E. A. Kaida, "Dinamicheskie harakteristiki dvuhmostovogo nizkochastotnogo kanala kompensatora neaktivnoi moshnosti," *Tekhnichna electrodynamika*, Kiev, IEDNANU, P.4., Tematchnui vup., 2009, pp. 63-67.
- [2] I. F. Domnin, E. A. Kaida, "Mnogokonturnaya Sistema upravleniya philtrokompensiruyushim ustroystvom," *Tekhnichna electrodynamika*, Kiev, IEDNANU, P. 2., Tematchnui vup., 2010, pp.44-47.
- [3] E. A. Kaida, "Nechetkoe regulirovanie ustroystvom kompensacii neaktivnyh sostavlyayushih polnoi moshnosti," *Tekhnichna electrodynamika*, Kiev, IEDNANU, P.1., Tematchnui vup., 2011, pp.184-188.
- [4] I. F. Domnin, E. A. Levon, V.P. Severin, "Optimizaciya parametrov cifrovogo nechetkogo regulyatora," *Tekhnichna electrodynamika*, Kharkiv: NTU«KHPH», P.2, Tematchnui vup., 2012, pp.91-94.
- [5] I. F. Domnin, E. A. Levon, V. V. Varvyanskaya, "Fuzzy logic based control system of converter for powerful sounding pulses generator," *Visnik Nacionalnogo tehnicnogo universitetu «Kharkivskiy politehnicnuy institut»*, Kharkov: NTU«KHPH», № 47 (1089), 2014, pp. 22-27.
- [6] O. O. Levon. *Napivprovodnikovuy dvokanalnuy regulyovanyu kompensator neaktivnyh skladovuh povnoi potugnosti: diss... Ph.D.:* 05.09.12, Levon Olena Oleksandrovna, Kharkiv, 2015, 200 pp..