

Beyond Technology

Children's Voices and Digital Realities at School

Helena Björk
Andrew Doyle
Eva Hartell
Riikka Hohti
Mathias Mose Olesen
Kathrin Otrell-Cass
Bjarne Poulsen
Olli Rekonen
Katariina Stenberg
&
children from
Denmark, Sweden
and Finland

Contents

1	Introduction	4
2	Smart with phones on museum visits	6
3	Science is like solving puzzles	10
4	Introducing micro:bit in the Swedish primary school	14
5	Classroom life with smartphones	18
6	About the pressure of managing instant messaging	22
7	What parents should know about children's use of smartphones?	24
8	The children's smartphone manifesto	28
9	Final thoughts	32
10	About the Authors	34
	References	36

Beyond Technology
Children's Voices and Digital Realities at School

Authors: Helena Björk, Andrew Doyle, Eva Hartell, Riikka Hohti, Mathias Mose Olesen,
Kathrin Otrell-Cass, Bjarne Poulsen, Olli Rekonen & Katariina Stenberg

© Aalborg University Denmark
ISBN: 978-87-93058-64-4 (PRINT)
ISBN: 978-87-93058-65-1 (E-PUB)



About this project, book and us

This book describes the findings of the research project 'Beyond Technology' funded by Nordplus Junior (<http://www.beyondtechnology.eu>).

The project was collaboratively carried out in three countries, Denmark, Sweden and Finland by students, teachers and researchers from Sofiendalskolen, Aalborg, Denmark together with Aalborg University, Ribbybergskolan, Haninge, Sweden together with KTH Royal Institute of Technology, Stockholm, Sweden and Viikki University Training School, Helsinki together with Helsinki University, Finland.

The aim of the project was twofold: First, we wanted to identify the practices, and appropriateness of use when primary school students use 'Bring Your Own Device' (BYOD) technology at school. Such technology could include any kind of smart technology (phones, tablets), but also cameras, digital watches and any applications that such devices may be using to access information or collect data. Second, we were interested how school-owned technology is used to connect with such devices including if they are used to collect information from students.

Our intention was to examine those practices in three country settings, to see if there are differences or similarities in practices, including those to do with trusting the handling of information with technology. We wanted to explore what it means for teachers and students at school especially when students bring their own technology (computers, phones) to school. The project involved networking and collaborative explorations of teachers, students and researchers. It resulted in the production of a variety of material resources that are publicly shared about our impressions of the opportunities and challenges of working with digital devices at school.

The aim to bring together different knowledges and practices across three Nordic countries, as well as across groups of students, teachers, researchers and families, proved a fruitful one. We noticed that pedagogical practices have to be understood in context. This means that all the participating countries had common issues, hopes, concerns and practical experiences concerning technology in classrooms, but there were also differences. Different cultures, learning environments, habits and routines all influence technology use in classrooms. The picture of student-owned technology in schools is not only rosy, rather, the potentials and promises often come with challenges.

In this book we are presenting stories that emerged from our joint work. We hope that they can be of relevance to other teachers, teacher educators, researchers or adults with an interest in how technology impacts on young people's lives.

The stories we identified to share in this book:

- Technology use and integration by teachers in school (chapters 3 and 4)
- Mobile phones in young people's lives (chapters 5,6,7 and 8)
- Technology on the go (chapter 2)

Each story represents an insight and experiences from one country's context, however we believe that those practices are relevant across country contexts.

Background to the research that was conducted in this project

This project was first and foremost about networking and exchange of experiences. However, we also conducted research and our approach has been shaped by socio-cultural and socio-material/posthumanist theories (see for example Taylor & Hughes, 2016). Using those frameworks means that we examine learning as a social process that is shaped by the coming together of people, communities, materials, ideas, environments and spaces. With a particular interest in the technology in classrooms, the project used ethnographic – anthropological methodologies. The specific methods varied across the different research teams, but our collected data included interviews, document analysis and classroom observations where we kept field notes, video and audio recordings. A big focus in our project was the collaboration with teachers, students and at times their parents. In our analysis we examined this information often jointly with teachers and students to zoom in and out from the macro to the meso and down to the micro level of analysis. Our joint discussions across the country contexts allowed us to be reflective of our own practices and receive valuable feedback from each other.

By
Helena Björk
&
Eva Hartell

The mobile phones' being or not being in the classroom / teaching seems to be a contemporary issue that teachers across the world are struggling with. This chapter gives an example where we have tried to include the mobile phones as a learning resource but did not succeed so well to begin with, but had the opportunity to reconsider and succeeded better later on.

These classic issues, how, what, and why have once again gained attention with the entry of mobile phones into children and adults' everyday lives, as these have also affected what happens in schools. Over the past three years, we have had several discussions in class about how we use the Internet and our mobile phones in a good and safe way, but also how it can be used as an asset in teaching. In the beginning of 2016 we had a mobile ban in our school. Our school had barely a few digital devices for pupils to use and it is not allowed to ask pupils (not even those who have) to bring their own digital devices (e.g. computers or iPads) as schools seem to be able to do in other countries. This together made it, to say the least, very difficult to, for example, search for information online or document by photographs. This was resolved by doing it together in full class or that allowing students to use their own mobile phones however, the documentation was mainly handled by the teacher. Most pupils had their own mobile phones however, not all of them brought them to school on an everyday basis.

First attempt - a visit to the Medieval Museum

After a brief introductory overview of Medieval times, that gave the students an overview of the era in order to awaken their interest, they were divided into groups in a particular subject area, e.g. girls' everyday life situation or food in the Middle Ages. The groups would gather facts and present it to their classmates. The theme included a visit to the Medieval Museum in Stockholm, where they would gather information about their subject and they were encouraged to use their mobile phones to document the visit. This was the first time we encouraged students to use mobile phones during a study visit.

Once at the museum, we once again had a brief review to repeat what they were supposed to do and what the purpose was. Despite careful preparations, we noticed quite quickly that several groups had difficulties focusing on the task. The students seemed to be in a hurry.

When we were back at school and the students were starting to work, the students soon discovered that their photos were more or less useless (Figure 1). Their expectations, like those of us adults, was that mobile phones



would be a great help, but it turned out to be completely the opposite. The students had taken **lots** of photographs without directly knowing what they were photographing. The disappointment among the students was great.

"It started with the class being divided into groups that together would go around collecting information about the Middle Ages using mobiles. The problem was that many of us did not stop and read the information, resulting in that almost everyone just ran around and took pictures of every sign they could find. The groups were split and the pictures were blurry and almost impossible to recognise. When we got back to school we had to find the information online instead."

Ellinor, 10 years

"It went like this because I didn't check the pictures after I took them so some became blurry and therefore they were difficult to read the text on."

Stefan, 10 years

Afterwards, it is easy to say how we might have done it better but we thought we had prepared ourselves well.

We discussed together how they could do this differently. The pupils were both wise and thoughtful, and had clever suggestions on what could be done to improve the study visit. Fortunately we got the opportunity just a short while after at a study visit of 100 innovations at the National Museum of Science and Technology, in Stockholm.

Second attempt – The National Museum of Science and Technology

At the museum groups of students were asked to select an innovation and find out information and then present it to the class. Again, they were allowed to document their research with their mobile phones.

Before the visit we discussed what had gone wrong in the previous museum visit (at the Medieval Museum) and what was important to consider this time round. Students suggested the following:

- designate a person who takes photos and notes
- discuss in the group what should be documented / photographed
- check the image after it has been taken so that the quality is good enough
- maintain focus on the task

This study visit went much better. The students were more focused and could carry out the task in a much more satisfactory way. Almost all groups were satisfied with their work and everyone could use the information they collected for their work when they got back to school.

„It went better this time, when only one person took the photos instead of all of us.“

Algot

“It went really well at The National Museum of Science and Technology. We chose very carefully what to photograph in order to get what we needed/wanted.“

Kendra

“It is important to not photograph other people, for either they do not want to be involved or perhaps they are not allowed to be photographed. It is also important to focus on what you are supposed to do in order to make sure that you have something to write or work with when you return back to class.“

Tove

The examples above are about including mobile phones as tools for study visits, but it is really about more than that. Although pupils are used to handling their mobile phone, this does not mean that they know how to handle them as a learning resource. A lot has happened during this three-year project, inside and outside of school. For example, we have increased the amount of digital devices at the school and these digital tools are used more in instruction than they were when the project started. Mobile phones have grown to be a part of everyday life and many young people today are aware of both pros and cons when using mobile phones in different ways at home and at school. However, the teacher plays an important role in promoting this, and the pupils know that.



erkingens av...
i Stock...
tegg i tillverkningen av glödlampor med glöd-
volfram. Glödlampor fick sitt genombrott
10 och 1920 talet, tack vare volfram-
malampans första fabrik startade 1931
vhamnen i Stockholm. År 1947 var den
rsta glödlampsfabrik med 1350
en produktion på 50 000 lampor.

of light bulbs at Lumalampan
holm, 1940s (TM21528)
the manufacture of light bulbs
of tungsten. The light bulb
gh in about the 1910s, thanks
nt.

By
Bjarne Poulsen,
Mathias Mose Olesen &
Kathrin Otrel-Cass

... AND THIS IS ABOUT HOW DIGITAL TECHNOLOGY COULD FIT IN

Tool - and information competencies

Science investigations require that students make use of tools and various kinds of resources. Those materials support and shape the nature of what can be investigated and what experiences students may have. Our reflections in the following examples are based on teaching inquiry-based science and opening the classroom up to allow students to use various digital technologies, some being selected by the teachers and others by the students themselves.

Understanding search engines

When students search for information on the internet, they typically use major search engines such as google.com and bing.com. These search engines provide an overview of what already exists on the internet for those who need it. However, there are some challenges associated with information searching in general and the smart use of digital technologies.

Students need to be taught to be critical about the origin of information that these engines identify and whether the information found is valid, trustworthy, and up to date. Students need to be able to figure out whether the information that is retrieved goes deep enough, to help answer more detailed questions. Once the validity and reliability of the information is established, students have to figure out if the information they found is useful for the context they are investigating. This is also a challenge in an analog information search, but due to the convenience of search engines and the need to find specific answers, it is very important not to overlook those steps.

Another increasingly important aspect to being competent in searching online for information is the ability to recognise that there are financial interests of different groups and companies who appear in the search results. Sponsored websites are typically high on the search results. Websites also produce metadata, and key terms to ensure they are being found. Cookies and other legal (and sometimes illegal) spyware tracks where information is retrieved and creates, over time, very specific user profiles that remember e.g. gender, age and interests. So what is being found through search engines may be a result of technology outsmarting smart children.

In our 8th grade astronomy teaching program, some students were interested in how a gyroscope works. While they were searching they were presented with a trailer for a movie ("the fidget spinner movie"). They may have been profiled, recognised, and commercially targeted with information that was not at all relevant to their investigation on astronomy or gyroscopes.

... AND THIS IS ABOUT HOW DIGITAL TECHNOLOGY COULD FIT IN

Padlet for working together

The padlet (padlet.com) is a virtual 'bulletin board' that is well-suited for participatory learning, focusing on already existing knowledge and inviting the students' own ideas and knowledge. Combining a constructivist learning approach with the puzzle analogy shows the meaningfulness of using the padlet. Existing knowledge is verbalised and made visible through writing, pictures, or links online and these posts prompt new knowledge to emerge when students read the input of others. There may not necessarily be a logic in the formulated and visible posts, but they can disrupt existing student thinking and prompt new ideas that can lead to the restructuring of knowledge. Seemingly disorganised pieces of ideas will gradually fall into place.

When generating ideas, whims and differences in perspectives from a group and the group must be able to see and partly be inspired by each other's contributions, the digital message board Padlet can be appropriate.

The padlet allows for anonymity and this can be a good idea when initial ideas are collected. What is important for an initial collection of ideas is that the input is visible to others instantaneously. This can then lead to a whole cascade of ideas. No contributions are sorted out in the first place and there is room for the lopsided whim, which suddenly unfolds completely different angles on a challenge. There are no priorities in the incidents and the contributor with few innings does not stand out from her with many. Quantity does not necessarily mean quality. The tool allows you to arrange and organize whims according to different principles and logical levels. The paddle works on-line and can be used by people sitting in the same room or separately and over long distances.

The padlet is accessible from both smartphone, tablet, PC, or chromebook and as such is independent of which device is available.

Ideas for the padlet can be introduced simultaneously while being in class or at home and the padlet can be stored and processed later. One disadvantage may be that silly ideas and posts are not sorted out, but appear with other contributions and may cause confusion. The permanency factor of online posts is a good thing to discuss with students since this not only affects posts for school activities but any kind of online interaction.

Thinking through simulations

Inquiry based science education (IBSE) is a pedagogy that prioritises the learning process and the learning product. This means it is not only about learning how to ask questions but also about learning about how knowledge is created, validated, and communicated. This is typically achieved when students get a chance to conduct their own science investigations. However, doing 'real' explorations is often a challenge (time/space/safety). Computer simulations can be used to complement what can be done by students in class or in the field and have the advantage that (depending on the type of simulation that is available) students can ask "what if" questions since they typically include a number of selected variables that can be changed or modified.

In our classroom observations the students found computer simulations on the internet. They then went to show it to their teacher to ensure the simulation tool would be the 'correct' one to use in support of their investigation. So teachers and students were experimenting and exploring the simulation together to find out what can be learned.

Curriculums differ in different contexts however, programming is present in many countries. Programming was introduced as core-content in the Swedish technology subject in 2018 (SNAE, 2018), and the teacher may decide on how to interpret and enact it in the classroom. It is acknowledged that teachers do not often have the content expertise or confidence in teaching 'new' topics as they are assigned to the curriculum. This chapter reports on a brief intervention in a Swedish classroom, which is intended to support teachers in bridging the gap to teach programming in primary school.

Introducing programming and micro:bit

The introduction of programming as part of the Technology subject has been surrounded by many questions and considerations such as the content of programming and how it should be taught including scaffolding and progression.

This short project was undertaken with one teacher and her class of 25, 12 year-olds, and two researchers. Micro:bit (Fig. 1) was chosen as an appropriate resource to introduce the topic as it was originally designed to encourage children of this age to get actively engaged instead of being consumers of digital media. Developed by the BBC in the UK, the device and associated online platform has been adopted in many countries. The software is open-source, and accessible via their website without logins which facilitates its compliance in schools with GDPR. (Find out more here <https://microbit.org>)

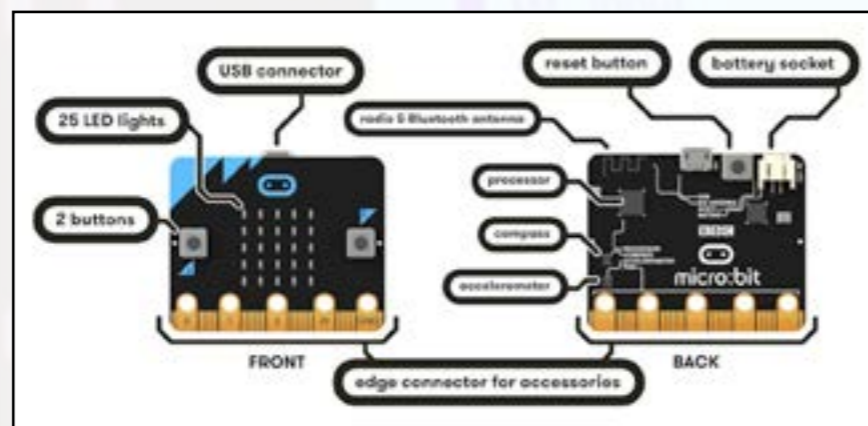

Figure 1 – Micro:bit

The first lesson focused on introducing programming, concepts like input-process-output, and software and hardware. Followed by a discussion on *what is programming and what is programmed?* This led the lesson towards

the online interface where after a brief introduction to the workspace and output area, pupils were led step-by-step through a simple activity –using the LED's to write their name. The objective here was to get all pupils familiar with the interface, and to show how then can program their virtual device. At the end of the lesson, the teacher and pupils were shown the on-line support materials and tutorials. Prior to the following lesson pupils were asked to explore other possibilities. In this introductory lesson the team decided not to introduce the physical resource.

The second activity began with a recap, where the pupils were asked to recreate the previous activity with some guidance. Subsequently, the class observed the development of a rock-paper-scissors game (Fig. 2), and spent some time recreating the code.

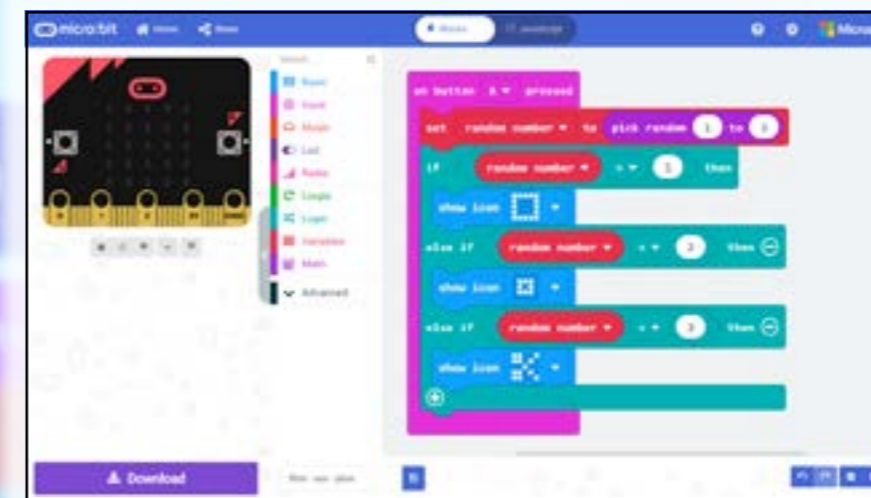

Figure 2 – Schematic of rock-paper-scissors game

Observations

The exemplar developed by the instructor was provided for learners to follow. In instances where some pupils completed the task before others, they were asked to explore modifications to the code (e.g. adapt it to assign a Hogwarts house). After all pupils had completed the initial activity, they were given the individual micro:bit devices and the transfer of code from the online software to the hardware was demonstrated. This was found to be a bit more challenging than the programming itself, especially for some of the pupils.

Pupils then explored for about one hour by themselves, where troubleshooting and problem solving started "to come in handy" (pupil comment). Explorations

Figure 3
Pupils Troubleshooting



moved beyond proof reading the code to troubleshooting the hardware, even as simple as connecting the battery and placement of the pedometer (Fig. 3).

These enquiry approaches grew gradually into a more exploration phase, and resulted in the developed of an assignment where pupils were given asked to design a device to measure something. On a subsequent visit the Research team were amazed by their progress and creativity. It was apparent that pupils catch on really easily and were able to design impressive “solutions” that also functioned as learning resources for their peers.

The following quote from a pupil (12 years old) captures the exploration activity:

I followed the instructions from the website to program it to measure steps. Then I was going to program one of the buttons to restart the step counter. But then I discovered that there was already such a button. This save a lot of time so I decided to program a love meter that really only selects a number between 0 and 100. Then I programmed the micro:bit to function as both at the same time.

As with much of technological activity, open and closed lesson activities complement each other. However, not every student does this and that is the challenge.

The research team were surprised how fast the pupils engaged in the activities. The structure of initially closed tasks followed by more permeable activities required more exploration and careful monitoring and guidance. Skogh (2001) argues that pupils require opportunities to engage with technology to gain the courage to try; thus, multiple opportunities to experiment are important factors in the learning process. This entangled relationship between opportunities and the courage to try technology is important, especially in the early years of schooling, emphasising that these opportunities should not just be provided in later years.

Conclusion

Schools should stimulate pupils' creativity, curiosity, and self-confidence, as well as their desire to translate ideas into action and solve problems. Pupils should have the opportunity to take initiatives and assume responsibility, and to develop their ability to work both independently and together with others. (SNAE, 2018, p. 8). Problem solving where to place the pedometer, to find the best location (Fig. 3), or collectively deciding on the max distance between communication devices and still receive messages are good examples of where pupils were given the opportunity to explore. This is not proposing to leave them learn by discovery. The pedagogical design provided for some basics in programming (the micro:bit) and opportunities to explore their ideas, with support from peers and scaffolding from their teacher and the research team.

From visiting this classroom, it was apparent that the culture of exploration is not a result of the micro:bit activity, but the classroom environment fostered by the teacher in partnership with the pupils for a long period of time. Different pupils have developed these skills to different “levels” and were supported by demonstrating them in different contexts. Emphasis should be drawn to the role that the teacher in fostering these varying applications. In this case study, the teacher facilitated collaborative work and peer critique and review. The value of individual contributions and abilities were apparent. One student in particular that has severe reading challenges was able to troubleshoot code like no one else in the class, they were also the foremost problem solver in the block programming in the group. In this particular activity we could see that some pupils were offered with opportunities to ‘take a step forward’ and they got the opportunity to show more of their true self, in these programming tasks.

We hope we have been able to show and encourage you to dare to provide your students with opportunities to learn in a subject area where you might not feel totally in control of, such as programming. The goal here was not to develop programmers, but using the technology to facilitate learners’ engagement with problems, and peers.



By
Riikka Hohi
&
Katariina Stenberg

Smartphones are present in current classrooms in many ways

Spending time in a 5th grade classroom, we observed smartphones slipping in and out of pockets, hiding between the pages of notebooks and being fiddled with during lessons – with or without permission. Phones gather people around them and play music to accompany crafts lesson. They are used for making videos for history lesson tasks, where pupils fetch facts and images that are later displayed using the document camera in front of the classroom. Smartphones open up new forces inside the familiar classroom space. Social media content, gaming, and all kinds of suggestions and dreams mix and mingle with the social and pedagogical layers of the classroom in a fraction of a second.

In Finland, the government announced a so-called digital leap, which maintains that every student should have guaranteed access to state-of-the-art digital devices. The digital leap however, has proceeded differently in various municipalities and schools, and in practice, pedagogies largely lean on those devices that are the easiest to find in classrooms, namely the smartphones that the pupils come to school with.

Our group of four Finnish researchers and teachers has been examining the change taking place in classrooms in connection with the use of smartphones as a complex and holistic shift. Specifically, we have been interested in the question, how does the “digital leap” look like from the point of view of its main characters; children, and young people.

How do phones fit in the school?

The familiar sight; a young person immersed in their phone, is always somewhat mysterious. Where are they actually when ‘being on their phones’? When a student has a smartphone, the connection to the Internet usually follows as a rule. One 13 year old pondered about this networked existence, reflecting how it would feel to be without a phone, saying that he would be as good as ‘a not living person’.

Commonly, technologies as parts of education are regarded as *means* to achieve pre-set rational goals. However, we have come to see that digital activity is never *merely* digital activity. With smartphones, new kinds of relations enter the school, and the school itself is less and less disconnected from the outside world. As the students visit their phones, the phones also visit the students, and global networks, ideas, commercial and political actors, and numerous modes of social interaction visit the students with them.

Contemporary Finnish school is loaded with history, which still bears traces of industrial-era ideas of efficacy of production and synchronization. In schools, few places are suitable for ‘hanging on the phone’. This is why smartphone-child-assemblages often can be detected in *between-spaces*, such as under the staircases or corridors. Smartphones are also often visited in *between-times*, such as the transitions between two lessons. The open-endedness that characterizes smartphone use is often in tension with the structures of the school.

The smartphone is a dear thing

The phone is a dear thing for the young people. Many 5th graders are very particular about how they use various covers, colors, stickers, and gadgets to decorate their phone and to make it distinctively *theirs*. When we looked at the photos and videos taken in the classroom, the power of smartphones as part of the classroom practice becomes visible. They glow in the dark, they invite people around them, and they bend bodies towards them and

are literally alive with sounds, vibrations, and signals. The phone even defines what clothes to wear, as the jeans and the jackets have to have pockets in which to transport the phone. Close to the body, customized as one's own, the phone is almost like a body part that belongs to oneself as naturally as the eyes or the hands.

Bodily existence with the phone can be a very personal and intimate experience. It could be described as companionship, in which the human and the phone share biographies and memories. In conversation, the children described their phone as their closest friends or their soulmates. The question, how would you cope without your phone, was met with hesitance: How do you wake up in the morning in the first place? How do you keep contact with your friends? How do you listen to music? How do you orientate yourself in places you have not visited before? How do you remember anything? The wide scope of these ponderings startled us. The message needs to be taken seriously; phones really matter to their young users.

The smartphone moves bodies and feelings

A load of affects flow through smartphones and their accompanying networks. An affect refers to a feeling or movement that can be felt individually, but also pre-personally across individuals, relations, and between-spaces. Affects can be thought as forces that can occupy, attach, move, and generate things and bodies. Affects help us to examine phenomena in regard with what makes them powerful and contagious.

Smartphones operate as points of connection to many kinds of affective media content. They create 'epidemics' which become visible as dance moves, sayings, bodily gestures, habits, and melodies being hummed. Both boredom and pleasure feature in smartphone use. But just as adults, children and young people also have ambiguous feelings about their smartphone use. When the teacher of the class, after several warnings, collected the phones in a box for the lessons, the 5th grade students responded with a surprising relief, almost gratitude.

Children know the meaning of addiction. On one hand, checking the phone means a moment of relaxation for them, on the other; the browsing often does not feel that relaxing after all. There are all kinds of commercial intentions behind the design of smart devices, which means that getting rid of networks of intensified relations of dependence can be really difficult.

We are in this together

Along with the official digital leap, there has been another, wilder kind of digital leap – or, as we have come to think of it, dance – going on in Finnish schools for some time. Its devices travel between the school and home in the pockets of the pupils. Why is it important to look at the use of smart devices in schools with an understanding of complexity? With mobile and wearable smart technology, parents, teachers, and students have to deal with a genuinely new phenomenon. Not only affects and relationalities change, but also the conceptions of time and place, social interaction, identity, and reality become unsettled and unstable.

The open-ended relationality accompanying pupils' own smartphones cannot be fully controlled; therefore it is often labeled as chaotic from the viewpoint of schools. Negotiations concerning smartphone use are now at the core of educational practices. Criticality is needed, but too simplified, instrumental notions tend to polarize power relations. One example of such simplified concepts is 'screen time', as digitality today is entangled in almost everything that makes people 'living': maintaining friendships, hobbies, cooking, and so on. Furthermore, there is no need for black-and-white approaches that view children either solely through risk, as vulnerable and in need of protection, or as unproblematic digital natives from birth on.

We propose listening to children and encountering their digitally entangled worlds. The issues with digitality, ultimately, concern both adults and children. What is worth to pursue, to a better quality of life, continues to be a relevant question.

By
Olli Rekonen

last seen today at 15:14

I have been conducting research on how the children of one sixth grade class at a primary school in Helsinki use their mobile phones to maintain and manage their social relations. The data for my study has been collected through focus group interviews with the students of the class. In this text, I will present one of my findings.

In light of the interview material I collected, it seems that children feel under pressure to respond to messages on their mobile phones immediately in order to take care of their social relations. The following interview excerpt shows this rather well. In it, one of the interviewed girls, whom I will refer to here as Sanni, says that others may become very angry with her if she does not answer to a WhatsApp message that she has received. In a case like this, she has acted against the norm that expects her to reply to a received message with a message of her own as soon as possible. If she doesn't do this, the friend who sent the message may frown upon her. In other words, WhatsApp sets up a norm of "you've seen the message, now answer" and puts pressure on Sanni to answer.

This is something that could not have happened to this extent before messaging apps like WhatsApp. This is because these kinds of applications show users whether recipients have seen messages or not and when they have last been online. In the excerpt below, Sanni talks about wanting to sometimes read messages without revealing this kind of information about her to the sender of the message. She does this by purposefully reading messages without opening the WhatsApp application itself to not reveal that she has seen the message. She does this so that the sender of the message would think that she hasn't seen the message yet. It could be argued that Sanni's thoughts convey a desire to sometimes take a break from the pressures of constant communication and contact that smartphones facilitate. Sanni was not the only one in the class to talk about this kind of pressure and describe different ways to take a break from it.

Sanni: *Usually if someone sends me a message and I don't want to talk to them I won't even go look at the messages. Because when I open my phone I get to this view where it shows the messages anyway. So, then I check what they had to say from there and if their thing isn't important, I don't even go to WhatsApp itself to look at it because then they would know that I've seen it...*

lina: *You can turn that mode off!*

Sanni: *... and if they see that I've seen it, they might get furious at me because I'm not answering. That's why I sometimes don't open the app to go see these messages.*

(To ensure the children's anonymity, I have not used their real names in this excerpt)

lina's comment on Sanni's thoughts reveals how the features of modern smartphones also make it possible to sidestep these pressures if this is what one wants to do. By adjusting the options of the app, it is indeed possible to use WhatsApp without revealing information on when one has last been online and whether one has seen a message or not. However, if this mode of sharing information is turned off, one cannot see this information on the WhatsApp profiles of others either.

What is the value in pointing these things out, though? After all, reciprocity has likely always been a part of the relations and communication between human beings. I would, however, stress the fact that technology hasn't always determined how the pressures of having to answer others play out in practice as strongly as it does today. Nowadays, a bigger part of communication than ever before operates through different technological devices. Of these the smartphone is the most prominent. Therefore, these kinds of issues are important to point out, research further and talk about with children and adults alike. Because the use of apps like WhatsApp has become such a central part of the lives of many children, it's important to dive deeper into their own views on how they use phones instead of just concentrating on adults' views on kids' phone use and its problems. Many children are far more aware of how they use their phones than we may think and it's not only the fun and games provided by phones that they have on their mind.

"On your smartphone you have to take action on the matters that come through then and there."

The presence of smartphones in children's worlds is a relatively recent phenomenon and is cause for wonderings and anguish for many parents. What limits should be set? How can they be controlled? How much must one know about the world in which their child lives? Parents can feel like the "bad cop" who acts as an appellant, or distributor of orders, and prohibitions, while the child's role is to obey or disobey commands of uncomprehending parents.

Inspired by this phenomenon, we decided to arrange a meeting for the fifth grade students and their parents. First, we assembled the pupils and asked for their thoughts on the question: „What should the adults know about the use of your smartphones?“ From the pupils' thoughts, three themes emerged: importance, confidence, and privacy.

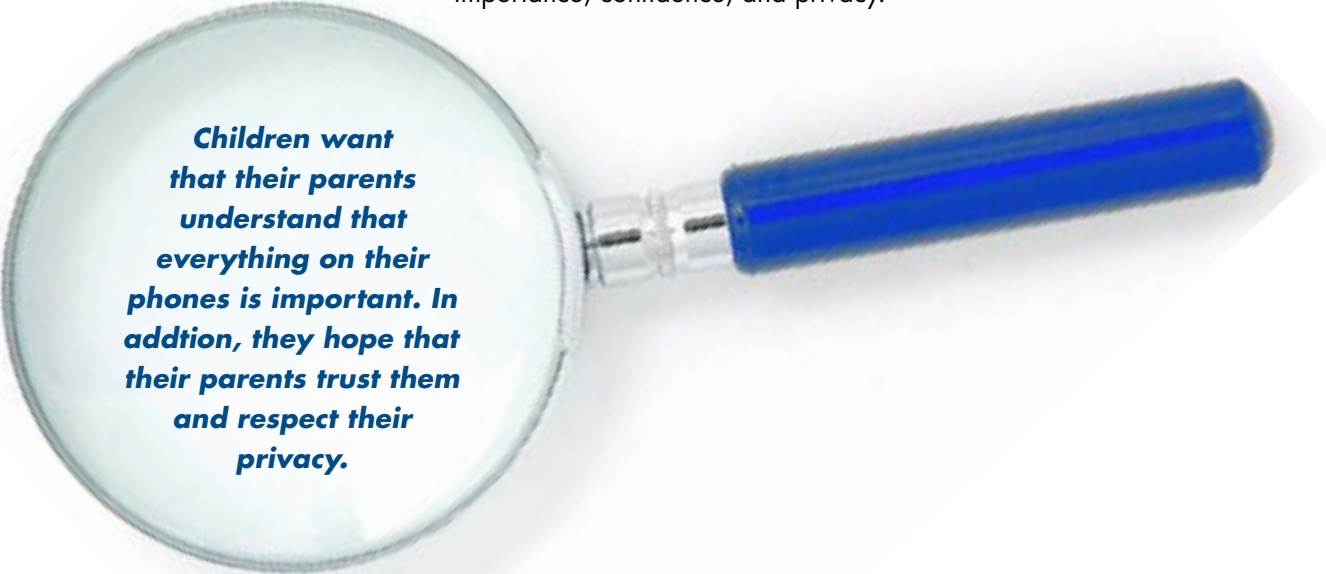

Children want that their parents understand that everything on their phones is important. In addition, they hope that their parents trust them and respect their privacy.

What did the children say?

1. Parents have to understand that everything on the smartphone is important

Many adults are worried about the fact that their child spends too much time on their smartphone. Adults may think that the „right“ life is one that is separate from the smartphones, and that the time that has been used for them takes away from time spent on better activities. The pupils want parents to know that life takes place through their smartphone, here and now. Many announcements come through the telephone and they have to be answered immediately. Messages may contain important issues and to address them, one has to look and respond to them. The messages have to be answered

By
Katariina Stenberg
&
Riikka Hohti

because the sender of the message can see if a message has been read. The parents do not understand that by interrupting, they interrupt something essential. With a smartphone, the issues need to be reacted to when they take place. Now, it is a question of the interaction, and about human relations. It is a question of important matters.

2. Parents should learn to trust their children

The children are annoyed by the adults' lack of confidence. Parents constantly ask their children who they are talking with. "With whom do you talk, in Facetime?" Or then the adults will imagine that whenever the child is with their mobile, he is playing a game. Parents want to know everything. Parents need to understand that children know what they are doing. It is a question of having confidence in children.

3. Parents have to understand that the smartphone is a private matter

Parents need to understand that children have a private life which also takes place through the smartphone. Social media is not a place in which children want to keep company with adults. It is not correct that the parents follow their children's activities on social media. It would be stressful if the mother were, for example, on Snapchat with the ability to see what is happening in their child's social life. It is a question of respect for their privacy.

How did the parents respond?

We then invited parents and the students to meet at the school to present the three themes to their parents. The parents were given the opportunity to respond to it. Their reactions to the theme one "Parents have to understand that the matters (we are dealing with through our smartphones) are important" emphasised that there is no need for the child to be constantly available. Parents wanted their children to understand that the world will not fall apart if one cannot give an immediate answer to messages. It is not a horrible thing. Parents wished their children realised this for themselves instead of the adult having to explain it to them. The liking and the marking of friends in social media also should not play too important a part in life. FOMO – the "fear of missing out" something important – cannot govern life. What is at stake is the courage needed to take control of one's own time.

In response to theme two, „Parents have to trust that the children know what they are doing“, parents brought up a concern about the limitless world. Social media is a window too many possibilities, but also to problematic issues and temptations. How can one know who is really behind their online pseudonym? If you get in the wrong company, fateful consequences may follow. Parents have a concern about the “double life” in which children can slip into. Therefore, it is the adults’ task to know what children do on social media. It is important to have open conversations between parents and children.

To the third theme, “The adults have to understand that the smartphone is a private matter“, the parents were asked about the role of social media in the lives of their children as well as families as a whole: Does it direct their actions too much? Should families do more together without digital devices or without social media? The adults understand that the smartphone brings and creates social protection, yet the children do not need to be alone. The parents’ task is to protect their children. The parents’ task is to make sure that their children get enough sleep. It is the parents’ task to ensure that their children can study and participate properly in activities. It is the parents’ task to make sure that social media does not lead to poor use of the children’s money. It is a question of life management and of security.



Parents wish that their children had the courage to be also without their smartphones and communicate with their parents about their phones.

The third round

Since only six students presented the three themes to the parents, another discussion was organised with the class where the responses of the parents were presented. We were enthused and waited for the students’ replies to the matters presented by the parents. Our objective was to create a genuine dialogue between the students and their parents; to build bridges instead of the setting up walls and to look for the joint solutions. However, the discussion lasted only about ten minutes. The students were not interested in the subject

at all. They were not interested in the thoughts of their parents. This made us wonder but we were also excited about the students’ attitudes. According to students, social media and smartphones are their “friends and their soul mates”, and a part of the being in their every-day world. The children look at their world through the ownership of smartphones and there is no need for a bigger discussion. The subject bored the children and they did not express a need to stay with the matter any longer.

Finally

In our discussions, In our discussion with the children we did not resolve the tension between parents and their children’s practices using their phones.. For the students, their life with smartphones is self-evident and clear. There is nothing to talk about with their parents. They just need the parents respect their privacy; children need no boundaries but should be simply trusted. Parents, for one, pointed out that the children should have the courage to spend more time without smartphones and learn life management instead. In addition, the parents felt that the children should communicate with them for building the shared trust.

In the contemporary world, the role of the police is given to the parents and thus they see themselves as the bottleneck between the children and their world. Is there any solution to be found, so that there would not be any boundaries between the children, smartphones, and the parents? In our opinion, this is a complex issue and we must avoid polarisation and oversimplification. It is important to understand the manifold character of the phenomenon instead of looking for clear answers.

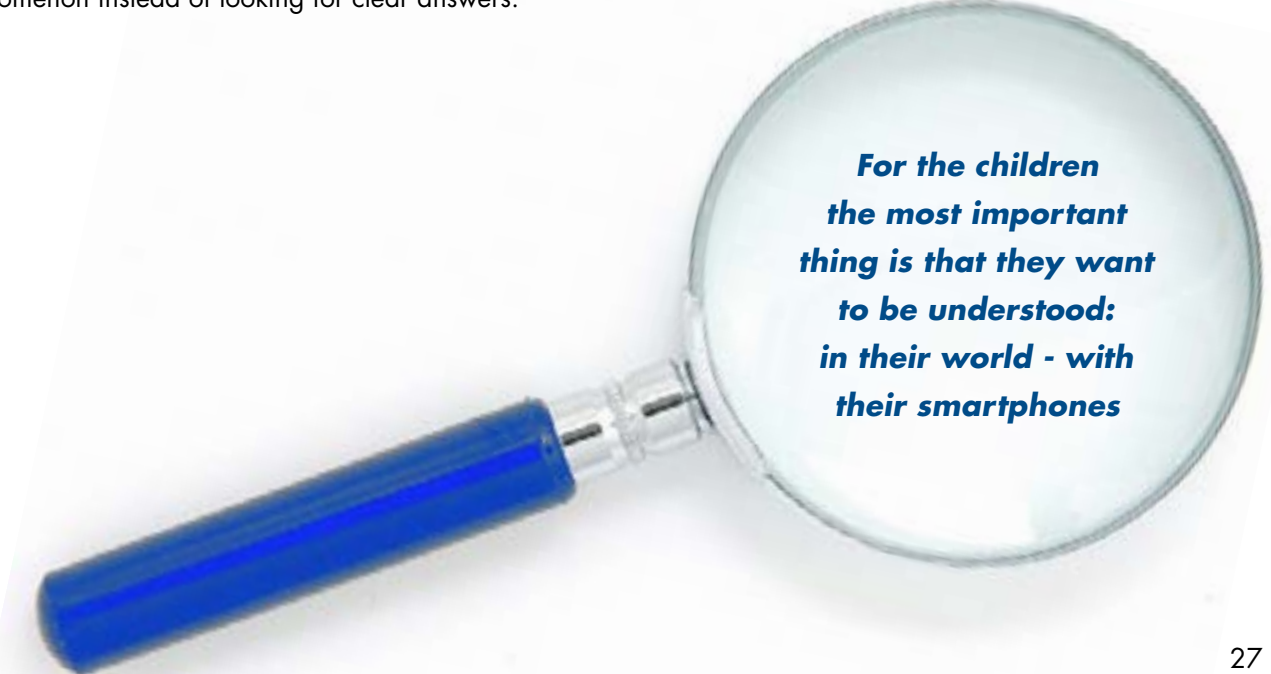

For the children the most important thing is that they want to be understood: in their world - with their smartphones

By Class 9.z
at Sofiendalskole
with Mathias Mose
Olesen, Bjarne Poulsen &
Kathrin Otrel-Cass

We asked the children at Sofiendalskole to share their thoughts about their lives with smartphones. Through process of telling the teachers and researchers, the teachers and researchers retelling the class what they thought they understood, and the class adjusting those thoughts we produced the **children's smartphone manifesto**.

Part 1 LIVING IN A WORLD OF SMARTPHONES

1. Why we depend on our phones

We have become addicted to checking our phones. Maybe this is due to poor self-control, but since phones are with us all the time, they impact on how our lives are organised and, on our wellbeing, (e.g. at night when we are receiving messages). However, it is not the smartphone that is addictive, but the apps or websites that we use through them, including social media like Facebook, Snapchat, or Instagram. Video or online games are designed to make one come back, day after day. Notifications and reminders to look at, or respond to, interfere with our lives. We must take more control over the technologies we use. Most phones have "do not disturb" or "flight mode" functions to stop interruptions. The high chance of dependence on the phone's applications means that we learn about their powers, familiarise ourselves with functionality and, take charge and manage how this technology interferes with our lives.

2. Why we are getting used to being bored

We get quickly bored without our smartphones. We have become used to the tools on our phones on long journeys because they provide us with entertainment, and this means that we can also get bored without our phones easily. This has led to a phenomenon: today's young people are bored, not only occasionally, but usually. Since the smartphone can do so many things, they are a hit among many young people when they travel, have to wait, or want to spend time by themselves. But you can also get bored with your phone and we have become used to being bored.

3. Why it is so important to learn about smartphone functionality

It is really important to understand what functionalities phones actually include and if they are actually needed. The function we call "phone" is the least used part, but it is often why we buy phones since it seems important to be able to receive calls and call if you are in an emergency. Many functions we have on our phones are unknown to us since we switch between different brands and new phones are constantly appearing with new features. Software updates create new opportunities for using phones for new things (including that companies can find out more about the things we are doing). Many important functions are overlooked if you do not use them in your everyday life. If older people have never had a smartphone or only

very simple ones, they could use the help of young people to find out about functionality and help selecting phones for younger children.

4. Why using a smartphone has to do with maturity

Since smartphones give access to many different applications with different features and functionalities, we should take great care with the age of the user. Younger children may need 'light' phones with less functionality. This means that parents and adults need to familiarise themselves properly with the functions on the smartphones their children have and perhaps lock parts of the smartphone functionalities and this is specifically with the use of social media apps — also since some of them have age restrictions. This is important because young people are communicating through those platforms, not only with friends, but with unknown strangers and other entities entirely. Parents need to think and talk about their child's maturity and be aware that there is still a risk that things can go wrong.

5. Why it is important that everyone takes responsibility

Smartphones are powerful tools. Parents and adults have to take responsibility to understand what these tools can do. Parents should teach their children that phones can be used for special and important things (sending messages or making calls). It is necessary to learn how to download apps and search on the internet and it is necessary to supervise younger children when they use different apps. Parents must decide when a young child is ready to get a smartphone and talk about how to use it. This should be an essential parenting skill. Ethics and good manners must be given priority. Most children will learn very quickly how to use smartphones, but it is harder to learn about good behaviour and the right conduct with phones. Parents and adults must think about their own actions when using smartphones.

Part 2 SMARTPHONES AT SCHOOL

6. Why we need to pay attention to attention

Smartphones bombard us with messages from our friends, from games, or other groups who try and get in touch with us. When our phones are on us in class, they can disturb our attention for a long time. Incoming messages or 'snaps' tempt us to look at what has come in and focus our attention on other things. We do not even need to look at our phones; the notifications, alerts, and vibrations focus our thoughts on answering friends or taking a look and make us temporarily unreachable. We need to be more in control in order to not let the phone take our attention. We have to take active steps, for instance by turning the notifications off, putting the phone in a bag or out of sight, turning it on silent, or turning it off all together.

7. Bring your own device and ownership

Most young people come to school with their smartphones and sometimes are even expected to have them available for doing specific kinds of schoolwork. It is important to think about ownership of smartphones at school. It is a bad idea to take smartphones away from students because they will continue to think about their phones, and this means that they will concentrate less on the task at hand. It is better to talk to children at school so that they can decide with their teachers how to manage when smartphones can be used and when they should stay out of sight.

8. Why we should consider using smartphones for e-learning

Many school tasks are digital, and homework can be done anywhere and at any time, including using a smartphone. Useful features like calculators, photo or video cameras, or special apps can support classroom teaching. Smartphones are a great help for students with learning challenges like dyslexia. During easy tasks, you can listen to music on headphones (only if it does not disturb other students). You can do things quicker, e.g. taking pictures of work on the black/white or smartboard if there is not enough time to take notes, to help to remember things from class. Sensors on smartphone can collect interesting data for learning. Smartphones can be used like a Swiss Army knife for learning. But teachers can do the same: instead of students, teachers can take pictures and share them with students, especially if students do not have their phone on them or have not got a phone at all.

9. Why we need to think about how to handle our data

When children use their phones in school, their data or information can be collected by the teacher or the school. It can be good if children and their teachers decide what information to use to help them learn better. But, information is also collected by companies or people we do not know, or know about (search engines), who may want to sell something or use information about children without their knowledge or without the power to say no. Our data should belong to us!

10. Smart phones – smart kids – smart teachers

Children know a lot about smartphone apps that are not educational, and it can be useful if parents or teachers ask children for their advice on how to handle those apps. However, when smartphones are used for schoolwork, we often do not know those apps or how to use them (outside of calculators or cameras). This is when teachers have to show and explain about the functionality of those tools. You cannot expect children to know this just because they are young.

A pedagogy that considers the digital realities in young people's lives

Digital technologies are here to stay. They have impacted on everyone's lives in good and bad ways and young people are no exemption. The speed at which technologies will be developing requires from us that we have a very open and frank discussions with each other, including teachers, students, parents and the wider community. So we can talk about concerns, hopes and the possible consequences to do with digital technology in schools.

What we learned in this project was that the joint explorations between teachers, students, parents and researchers helped us to understand how practices at school are impacted by the use or non-use of digital technology. With our special focus on Bring-Your-Own-Devices (BYODs), such as smartphones, we also learned the importance to respect for each other's standpoints.

We have witnessed great opportunities for integrating digital technology, that can add something positive to young people's learning experiences and that require that teachers and parents have to become more open minded towards the opportunities that those devices can present to the learning experiences.

We also had very critical discussions about the negative side effects that can be experienced, especially when it comes to how smartphones impact on the wellbeing of young people and the responsibilities that we all have to take in addressing those side effects.

In this project we have learned about the educational system and working conditions for teachers and students in Sweden, Finland and Denmark and that we share similar challenges

Digital technologies are here to stay. So, it is up to us as communities to get together and manage the challenges and opportunities. We need to continue to investigate how educational partnerships between students, parents, teachers and researchers can operate to achieve such ambitions. What we have learned is that this is only possible if everyone is being given a voice.

Helena Björk works as a teacher for the younger years (ages 9-13 years) at Ribbybergsskolan, Sweden. She teaches all theoretical subjects but has a particular focus on Swedish, society orientated subjects and English. For three years now, she has been assigned developing the school's work on ICT as a teacher.

Andrew Doyle is a Doctoral Student in the Department of Learning in Engineering Sciences at KTH Royal Institute of Technology. His doctoral research focuses on the relationship between policy and practice in different technology education contexts. He is also interested in the philosophy of technology and the role of technology education for society.

Eva Hartell, PhD, STEM teacher in the area of classroom formative assessment. She has been very fortunate to work together with teachers, schools, and municipalities conducting practice-based research in Sweden and internationally. Currently based in Haninge municipality and at KTH Royal Institute of Technology. Her interest is to develop instruction in order to bridge teaching and learning in K-12 STEM classrooms.

Riikka Hohti, PhD, has worked as a musician, a class teacher and a teacher educator. She is currently postdoctoral researcher at the Faculty of Education, University of Helsinki, where her research interests include childhood and digitality, child-animal relations, multispecies inquiry, feminist posthumanist methodologies and care.

Mathias Mose Olesen, is a school teacher at Sofiendalskolen, Aalborg, Denmark. He teaches science and maths in the last three years of the mandatory school system. He has a big interest in using digital technology to support the understanding of science and mathematical subjects, e.g. the use of visualisations and simulations of planet interaction in space.

Kathrin Otrell-Cass, PhD, is Professor mso in science & technology education at Aalborg University and Professor in innovation in teaching and learning at the University of Graz, Austria. Her research interests include digital visual anthropology and digital culture and data-related practices. A strong focus in her work is the collaboration with teachers and students in science and technology classrooms.

Bjarne Poulsen, is a science teacher at Sofiendalskolen, Aalborg, Denmark for students from grade 7 to grade 9. He holds a PD in science advisory. His special interest in teaching is interdisciplinarity and the use and integration of technology in teaching.

Olli Rekonen is a masters student at the Faculty of Social Sciences in University of Helsinki, Finland and has done his master's thesis as a part of this project. The thesis concentrates on the effects smartphones have on social cohesion among school children. His research interests focus around the relationship between technology and children's everyday life.

Katariina Stenberg, PhD, is a university lecturer at the Faculty of Educational Sciences in University of Helsinki, Finland and has been a teacher in this project at Viikki training school, Helsinki. Her research interests include teacher education, teacher identity, reflection and theory-practice relationship. She is also interested in participatory pedagogy and dialogic pedagogy.

This book represents also the voices of children from Denmark, Sweden and Finland we were allowed to work with and a big thanks goes to them.

References



From left to right:

Kathrin Otrell-Cass, Katariina Stenberg, Bjarne Poulsen, Riikka Hohti, Mathias Mose Olesen, Eva Hartell, Helena Björk
Olli Rekonen, Andrew Doyle

Beyond Technology (2019, September 19). Retrieved from <http://www.beyondtechnology.eu>

Micro:bit (2019, September 19). Retrieved from <https://microbit.org>

Otrell-Cass K., Renken M., Peffer M., Girault I., Chiocarriello A. (2016) Inquiry-Based Science Education and Problem-Based Learning: Motivations, Objectives, and Challenges Relevant to Computer Simulations. In: Simulations as Scaffolds in Science Education. SpringerBriefs in Educational Communications and Technology. Springer, Cham

Skogh, I.-B. (2001). Teknikens värld - flickors värld : en studie av yngre flickors möte med teknik i hem och skola. Stockholm: HLS förlag.

SNAE The Swedish National Agency for Education. (2018). Curriculum for the compulsory school, preschool class and school-age educare 2011 (rev 2018) (2018th ed.). Stockholm, Sweden: Statens skolverk. Retrieved from <https://www.skolverket.se/publikationer?id=3984>

Taylor, C. & Hughes, C. (2016). Posthuman Research Practices in Education. Springer Palgrave MacMillan.