

PAPER • OPEN ACCESS

Artificial Neural Network versus Linear Models Forecasting Doha Stock Market

To cite this article: Adil Yousif and Faiz Elfaki 2017 *J. Phys.: Conf. Ser.* **949** 012014

View the [article online](#) for updates and enhancements.

Related content

- [Model forecasting of phase composition of electrolytic alloys Co-Ni-Mn \(part 1\)](#)
V V Schmidt and I G Zhikhareva
- [Qatar opens science park](#)
- [Combined deterministic – stochastic forecasting of monthly river flows for water management](#)
E Peksova Szolgayova, R Vyleta, J Szolgay et al.



IOP | ebooks™

Bringing you innovative digital publishing with leading voices
to create your essential collection of books in STEM research.

Start exploring the collection - download the first chapter of
every title for free.

Artificial Neural Network versus Linear Models Forecasting Doha Stock Market

Adil Yousif¹ and Faiz Elfaki²

^{1,2} Department of Mathematics, Statistics and Physics, College of Arts and Science, Qatar University, P.O. Box 2713, Doha, Qatar.

E-mail : ¹ aeyousif@qu.edu.qa ; ² felfaki@qu.edu.qa

Abstract. The purpose of this study is to determine the instability of Doha stock market and develop forecasting models. Linear time series models are used and compared with a nonlinear Artificial Neural Network (ANN) namely Multilayer Perceptron (MLP) Technique. It aims to establish the best useful model based on daily and monthly data which are collected from Qatar exchange for the period starting from January 2007 to January 2015. Proposed models are for the general index of Qatar stock exchange and also for the usages in other several sectors. With the help of these models, Doha stock market index and other various sectors were predicted. The study was conducted by using various time series techniques to study and analyze data trend in producing appropriate results. After applying several models, such as: Quadratic trend model, double exponential smoothing model, and ARIMA, it was concluded that ARIMA (2,2) was the most suitable linear model for the daily general index. However, ANN model was found to be more accurate than time series models.

1. Introduction

The stock market is instrumental in measuring the strength or weakness of a country's economy. In Arab countries, Egyptians took the initiative to set up a stock market in the 18th century, which is one of the oldest stock markets in the world. In gulf region, the oldest stock market was established in Kuwait in 1962 [1]. Over the course of the next few decades, other Gulf countries also progressed economically resulting in the establishment of stock markets in countries like the United Arab Emirates, Oman, and Qatar.

For over a decade, Qatar worked hard to overcome the challenges, and over the next 15 years, it was able to build a competitive Liquefied Natural Gas (LNG) value chain that was able to reach the global market [2]. It was also successful in scaling up, integrating downstream, and built its reputation as a reliable and flexible partner and supplier. By the end of the last decade, Qatar directed its attention to the opportunities in converting lean gas into clean-burning gas-to-liquid fuels (GTLs) and it succeeded tremendously. Qatar is now the largest exporter of LNG and GTLs in the world with a supply chain that spans the entire globe [2].

The Qatari government adopted a policy that aims to diversify income resources and evolving economic infrastructures. Specifically, the government extended the exploration projects in oil and gas sectors and offered many incentives that appeal to foreign investors to perform similar projects. With its strong and open economy, the government of Qatar is determined to establish international standards and practices [3]. Besides infrastructure, there are many opportunities in the financial sector as Qatar aims to be a regional hub for foreign financial institutions. Local and foreign investors can



avail the option of investing in Qatar Exchange, the country's stock market, which keeps a list of brokerage companies that facilitate business in Qatar for those looking to trade directly, thereby Qatar is currently experiencing in benefitting from the economic boom.

In Qatar, the stock market was established in 1995 under law no 14. After two years, in 1997, trade started with 17 listed companies and five brokerage firms. Work began with manual management of the trading floor. In August 1998, it was shifted to the central registration system. Within the next two years, the state of Qatar became the first country in the Gulf area to have the linkage with companies through the internet. At the same time, all manual trading systems were cancelled and trading became electronic. In 2002, it established its own website in the Internet and allowed investors to sell shares on the same day. After one year, the market was moved to a new building. By 2005, it allowed non-Qataris to invest in shares with a rate not exceeding 25% of the shares traded in the market. Then in 2006, both of the regular and irregular markets became integrated. In 2007, Qatar Exchange took membership of the World Federation of Exchanges (WFE). By 2009, Qatar witnessed a massive transformation into a world-class stock market when it signed a strategic partnership agreement with New York Stock Exchange (NYSE) Euronext.

As of now, 43 companies are listed for trading on Qatar exchange which are divided by seven sectors. The biggest sector is Bank Sector, which includes 12 joint-stock companies. Other sectors are: Service sector and consumer goods with eight joint-stock company, Industry includes 8 joint-stock companies, Insurance sector with 5 joint-stock companies, Transport sector includes 3 joint-stock companies, Real estate sector contains 4 joint-stock companies, and the smallest sector is telecommunications that includes 2 joint-stock companies.

Today, Qatar stock market has its own policy and legal power on this Exchange. The underlying vision of Qatar exchange is to support Qatar's economy by allowing the investors with a chance to trade fairly and efficiently. Qatar exchange is a part of Qatar's national strategy and to be global, it has signed an agreement with NYSE Euronext and renamed the market as Qatar exchange. It helps Qatar to be an important financial center in the gulf region. Finally, this initiative makes Qatar an attractive market, locally and regionally, for investors.

2. Neural Network

Predicting the stock market returns accurately can be a very challenging task in no small part because of the highly nonlinear nature of the financial time series [4]. Numerous studies have proven the existence of non-linearity in the financial markets. One very affective method to uncover this relationship is neural networks. Unfortunately, most of these studies failed to consider any alternative forecasting techniques. The also failed to determine the relevance of input variables, or consider the performance of the models under different trading strategies [5]. During the last few years, a number of hybrid models and neural network models were proposed for obtaining accurate prediction of the results in order to outperform the traditional linear and nonlinear approaches. This paper will evaluate the efficiency of neural network models which are known to be dynamic and effective in stock-market predictions [6]. Artificial Neural Networks have become the subject of interest of researches and studies in the last few years and are being applied successfully across a wide range of problem domains, such as: engineering, finance, geology, physics, and medicine. There have been many attempts to define neural networks formally. Artificial Neural Network can offer a valid approximation of a vast class of nonlinear process [7]. Researchers also added that, "*the most significant advantage of the ANN models over the classes of linear models is that ANNs are universal approximators that can approximate a large class of functions with high degree of accuracy*". In a recent research, it is stated that ANN models either control or at least resist the limitations of traditional forecasting models, including misspecification, biased outliers, and assumption of linearity [8].

Multilayer Perceptron (MLP) procedure yields a predictive model for one or more dependent (target) variables based on the values of the predictor variables. MLP is a widely used approach in regression-type problems. An MLP network consists of three layers: input layer, hidden layer, and output layer as shown in Figure 2. Neuron sums up the values of inputs parameters according to their assigned weights, and adds a bias. By applying the transfer function, values of the outputs would be determined. The number of neurons in the input layer is determined based on the number of input parameters [9]. MLP network is a function of one or more predictors (also referred to as independent variables or inputs) that minimizes the prediction error of one or more target variables (also referred to as outputs).

3. Data of the Study

Data for this study were obtained from Qatar exchange from January 2007 up to January 2015. Data were divided into two parts; the first part is used to identify a suitable time series model (January 2007 – December 2014) and the second part is used for model validation (January 2015).

Date: Date format for daily index is: Year, Month, Day; YYYY/MM/DD

Index Closing Value: The closing price represents the most up-to-date valuation of a security until trading resumes again the next trading day.

Figure 1 shows an increasing trend which reached its high peak at index 360 and dropped to the lowest point in between the year of 2007 and the beginning of 2009. This happened because of the global financial crisis which affected the stock markets all over the world. After that, the graph seems to be increasing with linear trend.

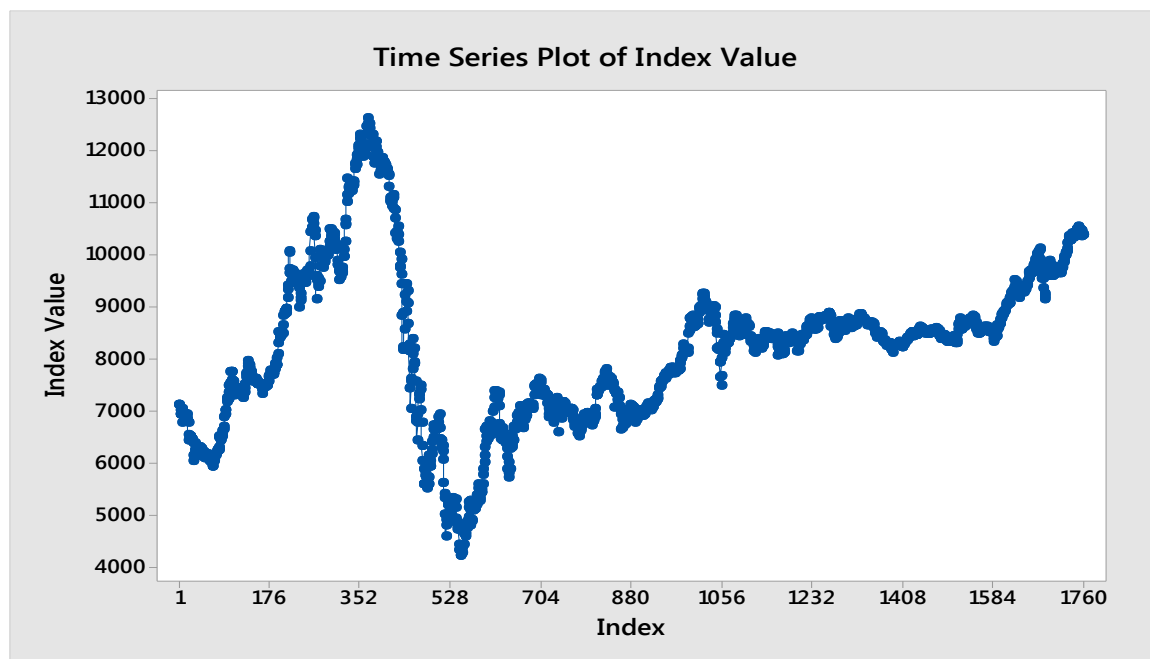

Figure 1. Daily Index Closing Value

4. Methodology

Two main methods were used for building a predictive model for the stock market data in the State of Qatar. Three time series models were utilized, namely: Trend model, Holt's Trend corrected models, and Box and Jenkins Autoregressive Moving Average (ARIMA) model. On the other hand, Artificial Neural Network which is one of none linear techniques was used.

4.1 Time Series Techniques

As the time series plot shows an increasing trend, several time series models were used. The Quadratic Trend technique was used, presented in equation (1), to investigate the trend of data.

$$Y_t = \beta_0 + \beta_1 t + \beta_2 t^2 \quad (1)$$

On the other hand the plot shows breakthrough in the level, which indicates parameters are not constant. So, Holt's Trend Exponential Smoothing Technique was also used for forecasting, as presented in equation (2) and (3).

$$L_t = \alpha \frac{Y_t}{S_{t-s}} + (1 - \alpha)(L_{t-1} + b_{t-1}) \quad (2)$$

$$b_t = \beta(L_t + L_{t-1}) + (1 - \beta)b_{t-1} \quad (3)$$

Equation (4) presents None-seasonal Autoregressive Moving Average (ARIMA) Technique which was also used as a mean linear stochastic model for forecasting.

$$Z_t = \delta + \varphi_1 z_{t-1} + \varphi_2 z_{t-2} + \dots + \varphi_p z_{t-p} + a_t - \theta_1 a_{t-1} - \theta_2 a_{t-2} - \dots - \theta_q a_{t-q} \quad (4)$$

4.2 Artificial Neural Network

Network model, which is used in this study, has a single hidden layer that contains n nodes. The model has feed-forward functionality. Linear neuron activation function of the network model is presented in equation (5).

$$y_{t+h} = \alpha_0 + \sum_{j=1}^n w_j g(\alpha_0 + \sum_{i=1}^p w_i y_{t+h}) + \sum_{i=1}^p \beta_i y_{t-i} + \epsilon_{t+h} \quad (5)$$

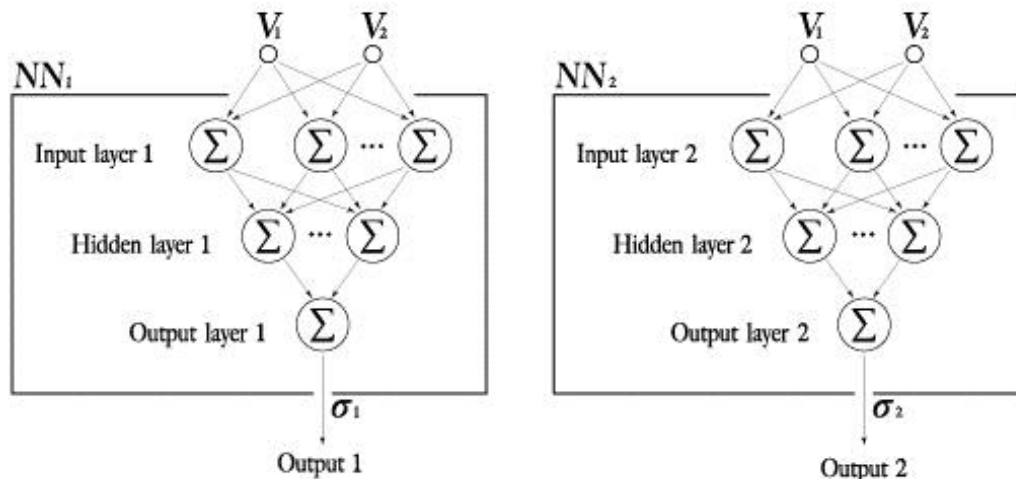

Figure 2. The Multilayer Perceptron (MLP) procedure.

5. Data Analysis and Discussion

Analysis of data for this study was performed via three linear time series models, which are: Trend model, Holt's corrected trend model, and Nonseasonal Box and Jenkins model (ARIMA). As a nonlinear model, Multilayer Perceptron (MLP) from Artificial Neural Network was also used. Among the linear models, ARIMA of order (2, 2) was identified as the most appropriate model with root mean square error (RMSE) as 287.97 as shown in Table 1. The Ljung Box Chi square statistic, as well as the

residual autocorrelation and residual partial autocorrelation were used to test the adequacy of ARIMA model.

Table 1. The Root Mean Square Error (RMSE) of the four models.

Model	RMSE
Quadratic Trend Model	42.19
Holt's Trend Model	26.31
ARIMA (2,2)	16.97
ANNW	3.01

On the other hand, when MLP was implemented using the hyperbolic tangent as a hidden layer activation function, the mean squares error was found as 82.3, the average overall relative error was obtained as 0.668, and the relative error for scale dependents was generated as 0.824. Table 2 displays the actual observation results for ten days which was observed after the period of the collected data and their corresponding point forecasts for ARIMA and ANN models.

Table 2. Comparison of the Forecasts for ARIMA and ANN models.

Day	Observed	ARIMA Model Forecast	ANNW Forecast
1	10526.95	10394.69	10458.17
2	10475.39	10383.96	10399.35
3	10468.59	10373.23	10406.84
4	10402.77	10362.51	10408.9
5	10453.15	10351.78	10477.88
6	10498.45	10341.05	10467.25
7	10462.54	10330.33	10409.01
8	10391.17	10319.6	10412.93
9	10360.02	10208.87	10317.48
10	10526.95	10394.69	10500.17

As it can be seen clearly in figure 3, Artificial Neural Network provided a better forecasting than linear time series models. On the other hand, ARIMA model appears to be the most suitable time series model followed by Holt's Trend model.

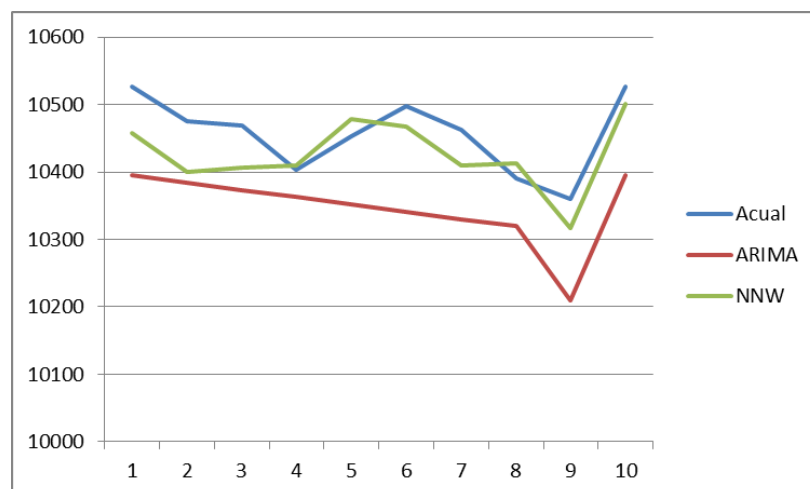

Figure 3. Comparison between Actual, ARIMA, and ANN models.

6. Summary and Conclusion

Qatar's stock market is a rapidly growing market which is due to the tremendous economic growth in the country [10]. As more and more companies are joining to the stock market, the number of investors increases as well. Therefore, it is essential that the investors should have an idea about the future of their investments. This future prediction can be done by modeling the data through several techniques.

This study analyzed the general closing index for the Qatar stock market from January 2007 to December 2016, as there was a drop in the time series because of the world's financial crisis in 2008-2009. Therefore, it was suggested by various similar studies, such as: studies on Saudi stock market and Johannesburg's stock market, to use data which are available after the crisis.

As the stock market is a highly fluctuating market, it is more appropriate to study the general closing index by analyzing data in daily basis. Based on time series plots, share prices for Doha stock market is continuously increasing and it was found that the data acquired a quadratic trend as it had the lowest mean absolute deviation (MAD) and mean square deviation (MSD). Holts' trend model, i.e. Double exponential smoothing model and ARIMA were applied and it was concluded that ARIMA (2,2) was the most suitable time series model for the daily general index. However, when Artificial Neural Network was applied, it shows a better forecasting than linear time series models.

References

- [1] Al-Loughani, N., & Chappell, D. (2001). Modelling the day-of-the-week effect in the Kuwait Stock Exchange: a nonlinear GARCH representation. *Applied Financial Economics*, 11(4), 353-359.
- [2] Ibrahim, I., & Harrigan, F. (2012). Qatar's economy: Past, present and future. *QScience Connect*, (2012), 9.
- [3] <http://qatarhelplinegroup.com/business-opportunities-in-qatar/>
- [4] Qiu, M., Song, Y., & Akagi, F. (2016). Application of artificial neural network for the prediction of stock market returns: The case of the Japanese stock market. *Chaos, Solitons & Fractals*, 85, 1-7.
- [5] Enke, D., & Thawornwong, S. (2005). The use of data mining and neural networks for forecasting stock market returns. *Expert Systems with applications*, 29(4), 927-940.
- [6] Guresen, E., Kayakutlu, G., & Daim, T. U. (2011). Using artificial neural network models in stock market index prediction. *Expert Systems with Applications*, 38(8), 10389-10397.
- [7] Babikir, A., & Mwambi, H. (2014, July). A factor—Artificial neural network model for time series forecasting: The case of South Africa. In *Neural Networks (IJCNN), 2014 International Joint Conference on* (pp. 838-844). IEEE.
- [8] Hill, T., O'Connor, M., & Remus, W. (1996). Neural network models for time series forecasts. *Management science*, 42(7), 1082-1092.
- [9] Moghaddam, A. H., Moghaddam, M. H., & Esfandyari, M. (2016). Stock market index prediction using artificial neural network. *Journal of Economics, Finance and Administrative Science*, 21(41), 89-93.
- [10] Sullivan, A., & Sheffrin, S. M. (2003). *Economics: Principles in action*. Upper Saddle River, New Jersey 07458: Pearson Prentice Hall.