



## Environmental Application with Multi Sensor Network

Ade Silvia Handayani<sup>1</sup>, Nyayu Latifah Husni<sup>1</sup>, Siti Nurmaini<sup>2</sup>, Rosmalinda Permatasari<sup>3</sup>

<sup>1</sup>*Department of Electrical Engineering Politeknik Negeri Sriwijaya*

<sup>2</sup>*Intelligence System Research Group, Faculty of Computer Science, Universitas Sriwijaya*

<sup>3</sup>*Department of Civil Universitas Tridinanti Palembang*

\*Correspondence: [nyayu\\_latifah@polsri.ac.id](mailto:nyayu_latifah@polsri.ac.id)

### ABSTRACT

This paper aimed to monitor temperature, humidity, and CO gas level using environmental application with multi sensor network (MSN). This system was applied in real life and real time, to be able to obtain data and information through mobile devices and other on internet network. In this research, environmental application is monitored remotely using displays on the web and sensors as device. This research obtained data in outdoor and indoor parking area also with obstacles and without obstacles, so it obtained the results from each of the different environmental conditions.

**Keywords:** Wireless Sensor Network, Environmental Monitoring, Web, Data Communication System, GPS.

### 1. INTRODUCTION

The technology of sensor such as embedded systems, wireless communications, distributed processing and wireless sensor applications have contributed in development Multi Sensors Network (MSN) recently [1]. A multi sensor network is type of wireless network. Basically, it consists a collection of tiny devices are called sensor node. Sensors node are multi-functional sensors that are small and can communicate in short range [2][3]. MSN can communicate between one node and other nodes wirelessly. Communication systems that are carried out wirelessly can communicate with each other to a network [4]. To be able to receive and send information to users according to the desired characteristics. Information characteristics that can be received and sent by the MSN such as information about environmental conditions.

MSN is able to receive information about the environment that is supported by intelligent devices automatically to optimize task schedules in real-time[5]. The real-time tasks carried out by MSN have great potential for various fields of application such as tracking military targets and supervision[6], natural disaster assistance[7], biomedical health monitoring[8][9], and exploration of monitoring of hazardous environmental conditions and seismic sensing[10]. Environmental application with multi sensor network consists of multiple many sensor nodes in a wireless communication-based environment. In environmental condition monitoring applications, Vishal Garg and Mukul Jhamb use MSN in disaster response and environmental monitors with localization techniques for sensor nodes in 2D locations[11]. However, in this case, researchers did not apply the localization technique to sensor nodes in 3D rooms because maintenance in 3D rooms was more

expensive and the algorithm calculation was more increased compared to localization in 2D sites.

The utilization of MSN in environmental monitoring was also delivered by Alan Mainwaring et al. in gathering information collected from animal habitat[12]. This research designed applications that function to identify important areas of further work in data sampling, communication, network retaking, and health monitoring. But the power used in the operating system is only enough to operate for six months. The operating system on the MSN is also implemented by Prachi Sharma in the environmental monitoring system. The operating system is run in real time to monitor water quality, soil moisture quality and monitor environmental conditions on volcanoes[13]. But it does not prove that the data produced is accurate because this research did not use algorithms or decision-making methods so that data in monitoring environmental conditions becomes less accurate.

The development of MSN in monitoring environmental conditions can provide solutions to problems in disaster-prone areas and areas that have a high level of vulnerability to disaster risk. Therefore, warnings need to be given regarding information on environmental conditions, such as conditions of air temperature, air humidity, CO gas levels and rainfall intensity. So that it can provide an appropriate response to environmental conditions that occur.

In this study, a monitoring system device was created that aims to monitor the sending and receiving of information regarding environmental conditions with distance as a parameter. The advantage of this technique is a monitoring system device designed to get a good distance through the results of sending and receiving information about the environmental conditions obtained at the MSN. This monitoring system can work optimally and allow the data obtained to be more accurate with the appearance of the website. It also can detect the location or location of sensor nodes using GPS (Global positioning system). GPS is one of the most successful positioning systems in the outside environment [14]. In this case, the GPS is used in the environmental monitoring system to determine the position of the sensor nodes scattered in several locations in the environment. Users can know the environmental conditions displayed on the website remotely using a website that is more friendly and simple and can display a lot of information such as the location or location of sensor nodes.

Information about environmental conditions and the location of sensor nodes are designed with a software system developed with the main module and fuzzy logic. The main module is used for sensor node and GSM communication. While Fuzzy Logic is used as a control in making decisions on monitoring systems on environmental conditions so that the data obtained becomes more accurate.

## **2. STUDY OF LITERATURE**

### **2.1. WIRELESS SENSOR NETWORK (WSN)**

Wireless Sensor Network (WSN) is an autonomous device that is specifically distributed using sensors in monitoring physical or environmental conditions such as temperature, sound, vibration, pressure, movement in different locations [15]. Cooperatively, WSN passes data through the network to the main network or Base



Station, which is the location where data can be observed and analyzed and act as an interface between the user and the network. WSN as an interface between users and networks in various fields that are used to monitor system. In paper [16], Goran Martinović showed research that can control micro-climate conditions based on zones, detect objects based on temperature maps and the minimum energy released. However, this research has not provided comparative results of measurements from various climates. In [17], Patricia Morreale utilized WSN as monitoring system for monitoring the temperature, humidity, air pressure, and sunlight with real time monitoring. Overall, the monitoring performance has been positive. However, this study does not prove that the system has an expansion of functionality for reading time. WSN is also implemented by Alan Mainwaring [12] to season monitoring. WSN can provide data on insights about climate and seasonal activities, humidity and constant air temperatures. Monitoring is carried out in real time and continuously on season variables. It can help people improve the quality of knowledge about the current season's activities. The design also includes the implementation of all necessary network services and data can also be accessed remotely. In paper [18], WSN to monitor the environment in the greenhouse, temperature, humidity and the intensity of the lights around the greenhouse environment. Continuous monitoring can increase the production of plants with better quality and be able to detect fire in the event of a fire in the area of the greenhouse environment. WSN in the environmental monitoring system has also been successfully implemented by previous researchers as showed in the table 1.

TABLE 1.  
Previous Research

No	References	Parameter	Method	Advantages
1	[15]	CO2; Temperature; Humidity.	Data Transmission (USART); Fuzzy Logic	Real Time; Portable; Low resource; Success for monitoring CO2 concentration
2	[16]	Green networking; Humidity; Temperature; Air pressure; Sunlight.	Mesh network; Prediction algorithm WINS; network operations.	Real time; Historical pattern; Overall the performance of the prediction model has been positive.
3	[17]	Greenhouse microclimate; Environmental controller.	Bug algorithm; RSSI signal propagating model; Fuzzy Analytic Hierarchy Process (FAHP).	Control climate micro conditions based on zones; Detect objects based on temperature maps; The minimum energy released.
4	[10]	Volcano activity; Raw-data seismic and acoustic signals; Base station; Onset time in waves during an earthquake.	Volcano monitoring; Signal in network processing algorithm; Fusing Model; Divide and conquer strategy; Fast	Near and real time; Continue; Quality of Signal high- fidelity

**Ade Silvia Handayani, Nyayu Latifah Husni, Siti Nurmaini, Rosmalinda Permatasari**  
**Environmental Application with Multi Sensor Network**

5	[18]	Behavior control; Communication channel; Virtual entity.		flourier transform. Dual swarm system WSN & MMR; Received signal strength indication (RSSI).	Multi system agent; Dynamic and complex system; Easy to interpret the collective behavior of MMR and WSN without any modification of swarm.
6	[19]	Greenhouse environmental; temperature; humidity the intensity of the lights around.		SMS; Topology.	increase production of plants with better quality; able to detect fire.
7	[12]	Habitat		Hierarchical network; Operating of the grid; System behavior; Data archiving; SQL database.	Data provides insight into climate and seasonal activities; Constant humidity and temperature; Energy is clear for all services.
8	[20]	Monitoring water quality; Monitoring the quality of soil moisture; Monitoring volcano condition	Water	Protocol BMAC	Open source Freeware; WSN operating system; Using a camera for shooting at the WSN location.
9	[21]	climate; Greenhouse production. Temperature; Humidity		Event based system; Simulink toolbox; Level crossing sampling.	Resolve greenhouse climate problems, satisfying results in climate monitoring and saving costs.
10	[22]	agriculture environment; microclimate.		Measuring agent; Microsoft SQL; RSSI.	Universal microclimate environment controls are stable; Fast adaptive control in a variety of conditions Successfully implemented with a mobile robot; Low cost; Fast response; Low maintenance; Real time.

Basically, the network in WSN communication is enabled in industry or other applications where the application has difficulty installing wireless networks. The areas of WSN use are pollution monitoring systems in the environment, fire detection systems, habitat monitoring areas, traffic monitoring, and other conditions [20]. WSN was also built from several sensor nodes scattered in the monitoring area. Sensor nodes are equipped with sensing and counting devices, radio wave transmitters and power components. Sensor nodes are often not only responsible for data collection, but also for network analysis and the combination of sensor data. Sensor nodes communicate not only with each other but also with base stations using wireless radio that allows disseminating sensor data to processing,

visualization, analysis and remote storage systems. The capabilities of sensor nodes in WSN vary greatly, one of which is the node can monitor a phenomenon.

## 2.2. MULTI SENSOR NETWORK (MSN)

Multi-Sensor Network (MSN) is a new technology by utilizing several sensors and the Wireless Sensor Network (WSN) in one device. The collected signals are transmitted to the monitoring center, which uses intelligent computers to automatically manage distributed resources and optimize task schedules in real time [21]. This system can produce data about automatically censored objects [22]. The tasks carried out by network sensors in real time can be applied to real life such as in disaster response, communication, transportation, factory automation, in the military field for battlefield surveillance, habitat monitoring, health applications, tracking targets, environmental monitors and others [23][24][25]. In the application of environmental monitoring, it will produce the quality of temperature, humidity, CO<sub>2</sub>, pressure, shift, and climatic conditions where the working system can be accessed through the internet both browser and mobile devices [15].

Sensor networks with WSN applications on environmental monitoring have been carried out by several experts who have proven that WSN is able to monitor the environment properly. According to [4], WSN has important applications such as remote monitoring and target tracking environments. These sensors equipped with a wireless interface that can communicate with each other to networks. WSN design is very dependent on the application and must consider factors such as the environment, application design goals, costs, hardware, and system constraints [26][27].

On MSN, the characteristics are the same thing as WSN [28][29], to enable WSN applications using sensor technology, various tasks can be broadly clarified in three groups; first is system. Each sensor node is an individual system. development of new platforms, operating systems, and schema storage is needed to support different application software on the sensor system [30]. Second is the communication protocol that allows communication between applications and sensors [31]. This allows communication between sensor nodes. The last is services developed to improve applications and improve system performance and network efficiency [27].

MSN applications can be classified into two categories: monitoring and tracking. Monitor application included indoor / outdoor environment monitoring [32], health and welfare monitoring [33], power monitoring, factory and process automation. Track applications including track objects, animals, humans and vehicles. Although it has been widely tested on the indoor environment [14], but there is no implementation of the MSN system in the indoor parking area.

The design of the MSN platform must handle challenges in energy efficiency, costs and application requirements [34]. This requires optimization of both hardware and software to make MSN efficient. Hardware includes using small sensor nodes while low-cost, software problems such as network life, toughness, self-regulation, security, fault tolerance, and middleware. Application requirements vary in terms of computing, storage, and user interfaces and as a result, there is no single platform that can be applied to all applications.

### **2.3. FUZZY LOGIC**

Fuzzy logic is a multi-value logic obtained from a collection of fuzzy theories with human reasoning that ranges from 'almost certain' to 'very impossible'. The membership value of fuzzy logic variables is not only 0 and 1 but can range between 0 and 1 [35]. Fuzzy logic can handle information that results from computational perceptions and cognitions which are uncertain, imprecise, unclear, partly true, or without sharp boundaries. It possible to include human decisions that are unclear in computing problems. Computational methods based on fuzzy logic can be used in developing intelligent systems for decision making, identification, pattern recognition, optimization, and control. Many applications implemented the fuzzy logic in many areas [36], including modeling and control [37][38], time series [39][40], and data mining [41].

### **2.4. DATA COMMUNICATION**

Data communication is the process of sending information between two points using binary code through the transmission channel. switching devices can occur between computers with computers, computers with terminals or computers with devices [42]. Data communication is a combination of telecommunications techniques with data processing techniques. The purpose of data communication is to enable the transmission of large amounts of data and efficiently, without errors from one place to another.

In this research, data transmission utilized the SIM900A GSM / GPRS core IC communication module. This module supports dual band communication at 900/1800 MHz (GSM900 and GSM1800) so it is flexible to be used with SIM cards from various cellular telephone operators in Indonesia. GSM operators operating in dual band 900 MHz and 1800 MHz frequencies. This module has been installed on a breakout board (the core module is packed in a Surface Mounted Device packaging) with a standard header pin of 0.1 "(2.54 mm) to facilitate use.

### **2.5. GPS APPLICATION IN MSN**

The Wireless Sensor Network expands the ability to monitor and control the physical world. The availability of low power wireless communication allows the distribution of densely distributed sensor networks for a variety of biological and environmental monitoring applications, from sea to land and atmospheric contexts. Network sensors can collaborate and collect large amounts of sensing data to provide continuous and solid observation of biological, environmental and artificial systems [43].

In this sensor network system, a node is needed to be able to find the location or position of these nodes in various environments and on different distance scales. This is called localization but is very important for many applications from very large network devices. In context-aware applications, localization allows the selection of the right device and can support useful coordination between devices. GPS solves localization problems in outdoor environments for these sensor nodes. However, for large networks of very small, low-cost, and low power devices, practical considerations such as size, form factor, cost and power constraints of the

node block the use of GPS on all nodes. This study used a simple connectivity-based localization method for such devices in an unrestricted external environment. It utilized the data communication capabilities of the GSM modules that are attached to this device. A few sensor nodes in the network serve as reference points and transmit data.

GPS is the most successful positioning system in the outside environment. However, poor satellite signal coverage for the indoor environment decreases its accuracy and makes it unsuitable for estimating indoor locations [14]. GPS determinate to be able to find out the position of the node that is scattered in the environment requires a GPS that functions to receive signals sent from GPS satellites. The position is changed to a point in the form of latitude and longitude coordinates of the position of the sensor node at a location then on the screen on an electronic map.

### 3. DESIGN OF TOOLS

In this study, the development of making devices using MSN is divided into two parts; hardware and software design. Designing sensor nodes begins with making a block diagram of the sensor node as a whole. Block Diagram is one of the most important parts in designing a tool, because from this circuit diagram block can be known how the whole circuit works. So that the entire block of the circuit diagram will produce a system that can be used.

#### 3.1. SENSOR NODE DESIGN

Designing sensor nodes begins with making a block diagram of the sensor node. Overall, the sensor node block diagram is shown in Figure 1.

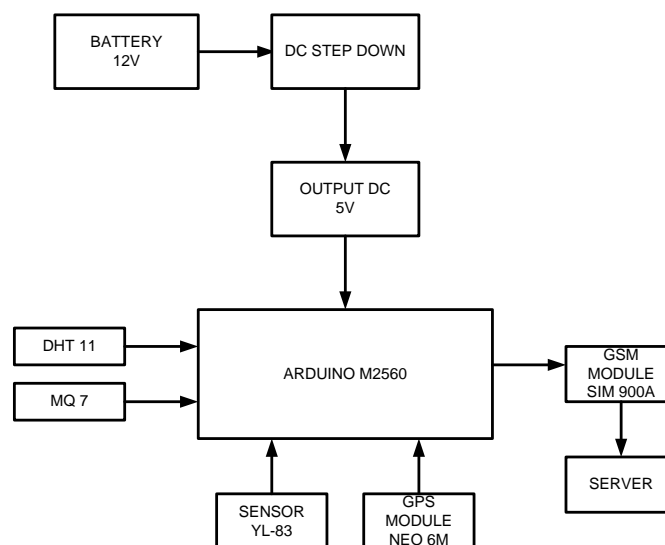

FIGURE 1. Diagram block sensor node design

The design of sensor nodes used the GSM SIM900A module as communication from the sensor node to the server. The server as data storage in the form of estimates of environmental conditions generated from sensor nodes connected to weather sensors such as rain sensors, air humidity sensors and carbon monoxide gas sensors. In the design of localization systems using GPS modules that are designed to determine the position or location of the sensor nodes. The function of access point as a connection to the server, and the sensor node as monitoring. In a monitoring system, the sensor nodes retrieve data through a server that is connected to an access point and then the data will be displayed in graphical form where the data comes from the sensor node via GSM SIM900A communication.

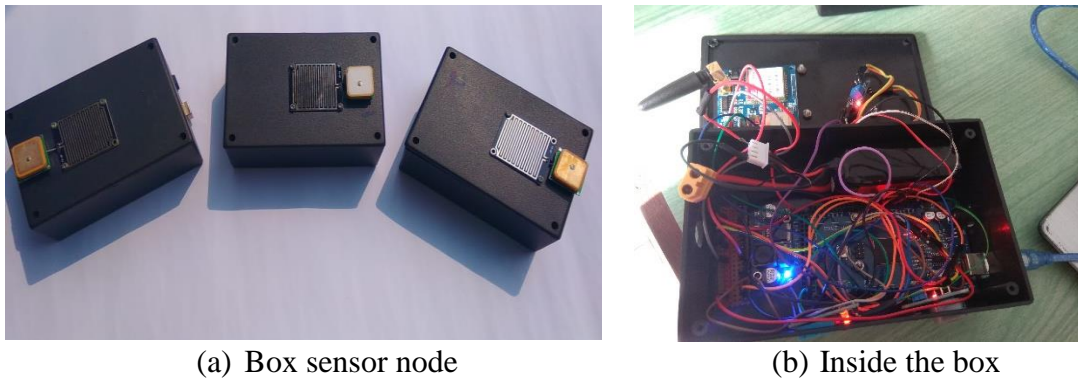

FIGURE 2. Sensor node

### 3.2. SENSOR NETWORK

Network sensors are designed with the main modules used for sensor node communication and for GSM communication and fuzzy logic. Fuzzy logic method is used as a control in making decisions related to the surrounding environment conditions based on sensor nodes and weather sensors utilized. The monitoring system is designed to be able to know the state of the environment in real time from sensor nodes and be able to control the temperature and humidity conditions, gas monoxide levels and rainfall intensity based on sensor nodes scattered at several points in the environment. Sensor Network monitoring system flowchart is shown in Figure 3.



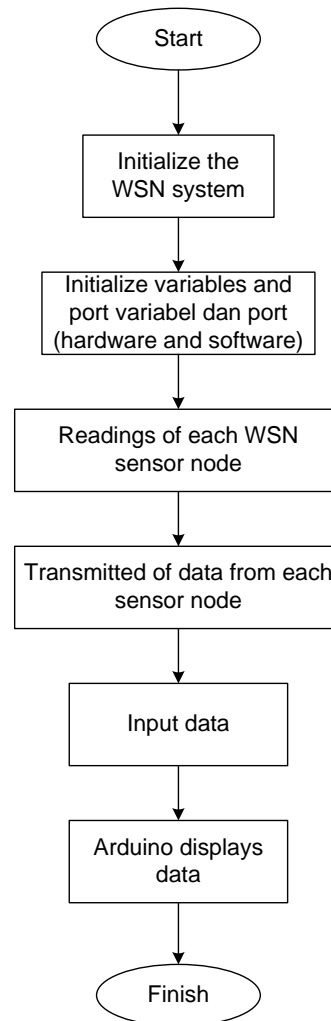

FIGURE 3. Sensor network flowchart

Data communication systems in network sensors are designed to send and receive data on each node. Communication systems are designed to sensor nodes can provide results in the form of position data and distance that has been obtained and sent through the server so that it can be read on the computer. In this case, the data communication system used GSM SIM900A which is used to send and receive data at each sensor node, so that the sensor nodes can provide results in the form of data that has been obtained and sent through the server so that it can be read on the computer.

### 3.3. MSN PERFORMANCE IN THE ENVIRONMENTAL MONITORING SYSTEM

Application of environmental monitoring system based on WSN technology with Fuzzy Logic method using weather sensors, GPS and GSM SIM 900A modules developed because the operating system used is open source. This application was made to monitor the environment around the WSN using Fuzzy Logic method for

decision making. It based on environmental conditions of temperature and humidity conditions, CO gas levels and rainfall intensity and GPS for determining position estimation on the sensor node from one position to position others in one location so that they can find out the information data and the position or location of the sensor nodes that will be displayed on the website.

In this research, WSN would be given several sensor nodes to determine the location of the position to be headed. All initial positions have been marked and determined through a monitoring system application as a reference for measuring the level of accuracy during execution on the WSN. As long as the WSN monitors the environment, the results of monitoring would appear with a better level of mobility, making it easier for settings in the monitoring system.

## **4. RESULT AND DISCUSSION**

### **4.1. ENVIRONMENTAL CONDITIONS IN THE ENVIRONMENTAL MONITORING SYSTEM**

Environmental monitoring system application has the ability to monitor existing environmental conditions in real time and determine the position estimation of sensor nodes in a location. The monitoring results would be displayed in the form of graphs and points of latitude and longitude coordinates of sensor nodes that have been integrated with the Fuzzy Logic method and GPS module used data communication from the GSM SIM 900A Module. In this case, the sensor node will send information about environmental conditions such as air temperature, humidity and CO gas levels. The monitoring results that have been read and sent by sensor nodes are able to be integrated on the website display so as to produce information and data as shown.

From Figures 4, 5, and 6, node 1 and node 3 are placed in outdoor parking area. The values of temperature and humidity at both locations are detected using the DHT11 sensor. Node 1 and Node 3 detected the same temperature value, which is 29°C. The humidity value detected by Node 1 is 38% - 39%. The humidity value at Node 3 is 56% - 39%. While the temperature value in Node 2 which is placed in the indoor parking area is 29°C with the humidity value is 41% - 48%.



**FIGURE 4. Temperature Monitoring**

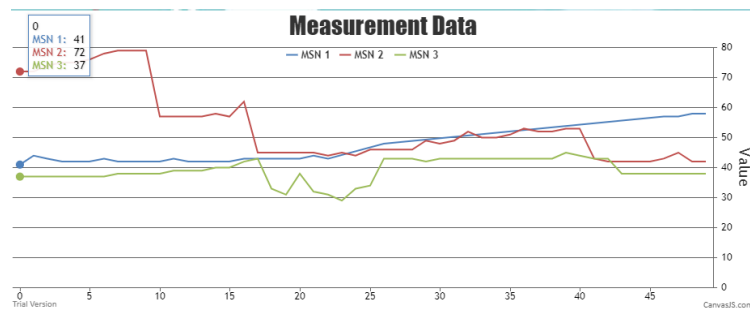

FIGURE 5. Humidity Monitoring

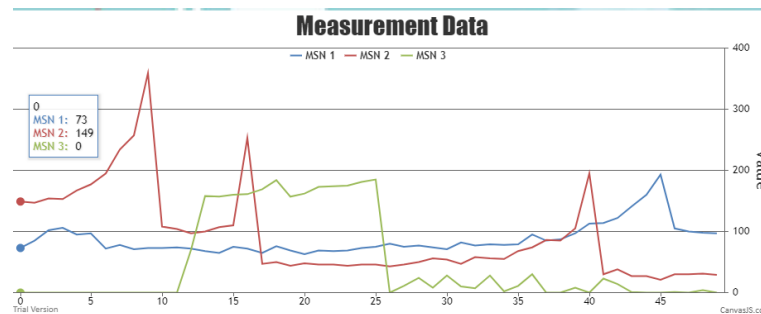

FIGURE 6. Gas Monitoring

Changes that affect the value of temperature and humidity in each place in the environment are the high and low places. The lower position of a device in a place or environment, the air temperature will be higher. The longer sun brightens the earth the higher temperature of the earth's surface and the movement of wind in an environment. The higher wind speed will accelerate the removal of moisture that billows in the air.

While in Figure 6 and 7, it displayed information about the gas state in the environment. Gas levels in the environment are detected by the MQ7 sensor and placed on outdoor parking area. The CO gas value obtained from node 1 is 40 ppm-68 ppm. Whereas Node 2 is placed indoor parking area with value of CO gas content obtained is 30 ppm-42 ppm. The gas level value at node 3 in another outdoor parking area is 20 ppm-30 ppm. In this case, the gas level in an environment is influenced by the number of vehicles and incomplete combustion. From the combustion process, vehicle fuel will cause high CO gas. This often occurs in the combustion process of motor vehicles, especially if the combustion process is incomplete.

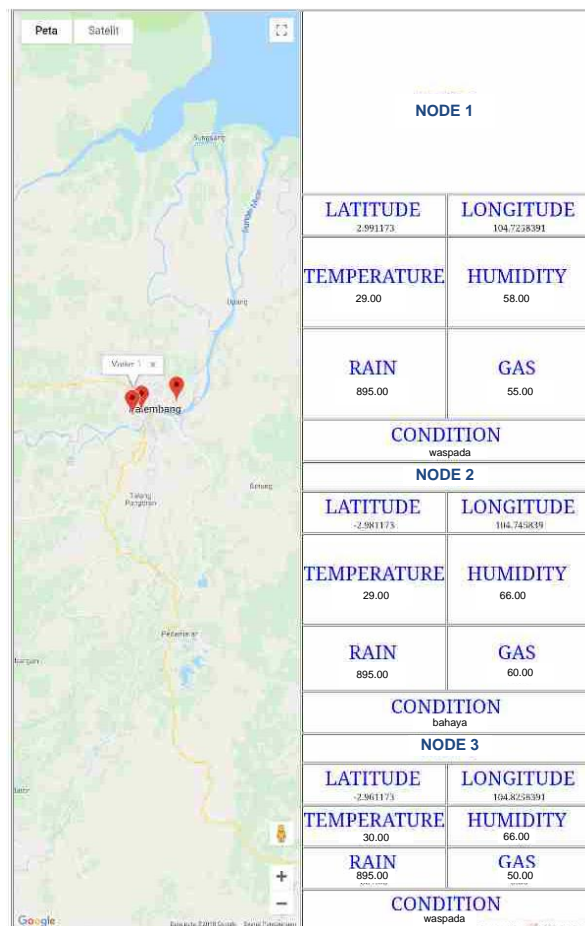

FIGURE 7. WEB Monitoring

#### 4.2. DATA COMMUNICATION RESULTS ON THE GSM 900A SIM MODULE

In this research, parameters used are the distance for sending data and the completeness of the data received from the node. At a distance of 1-100 m without obstacles, 1700 data is sent well without any interference as in table 2. It would be happened because the speed of data access from each node has no obstacles such as buildings, vehicles etc. which cause pulses of data sent to each node sent very well. The speed of access to data sent and received will be more efficient and accurate without any obstacles between the node and the server.

TABLE 2.  
Distance 1-100m without obstacle

Distance	Node 1	Node 2	Node 3
20 m	Sent	Sent	Sent
40 m	Sent	Sent	Sent
60 m	Sent	Sent	Sent
80 m	Sent	Sent	Sent
100 m	Sent	Sent	Sent

TABLE 3.  
Distance 1-100m with obstacle

Distance	Node 1	Node 2	Node 3
20 m	Sent	Sent	Sent
40 m	Sent	Sent	Sent
60 m	Not Sent	Not Sent	Not Sent
80 m	Not Sent	Not Sent	Not Sent
100 m	Not Sent	Not Sent	Not Sent

In sending data with obstacles, the data sent is only 700 data from a distance of 1-40 m. The results of sending data are due to obstructions such as buildings, vehicles etc. As in table 3, where the data pulses that are being sent to the server are absorbed or reflected by a barrier so that the connection between the node and the server is blocked.

#### 4.1. DATA OF NODE IN OUTDOOR

The first data analysis was carried out in the outdoor parking area of the Electrical Engineering building, Sriwijaya State Polytechnic. Data collection was carried out on 2019-04-29 from 03:42:10 to 03:48:15 with 100 data received. There are 3 nodes placed on the front entrance parking spread out. At node 1 and node 2 the data showed that the delay range is 10-20 seconds, but for node 3 the data shows that the delay range of more than 60 seconds is slightly different from the program that has been made which is 20 seconds because the signal on node 3 is blocked by the vehicle which is parked in the building and produces average air quality is relatively moderate as in the ISPU table, which is 50-100ppm.

TABLE 4.  
Data of Node in Outdoor Parking Area

No.	Time	Node	Temperature (°C)	Humidity (%)	Gas (ppm)
1.	03:42:10	1	32	61	171
2.	03:42:22	2	33	54	227
3.	03:42:28	3	33	61	89
4.	03:42:45	1	32	61	168
5.	03:42:57	2	33	54	226
6.	03:43:01	3	33	60	113
7.	03:43:09	1	32	61	179
8.	03:43:21	2	33	53	224
9.	03:43:56	3	32	62	75
10.	03:44:02	1	32	60	166
11.	03:44:08	2	33	53	225
12.	03:44:19	3	32	62	69
13.	03:44:22	1	32	59	154

Changes in data transmission each time and each distance are caused by the speed of data access sent from different nodes to servers. Each node has the same

provider type but these nodes are spread in different places. The closer the node is to the BTS, the faster the data sending connection will be. The decrease in data transmission occurs because of the delay and throughput which causes the signal speed to vary, so the data arrived at the receiver with a different time.

#### **4.2. DATA OF NODE IN INDOOR**

The second data analysis was carried out in indoor parking area of the Sriwijaya State Polytechnic Public Facilities. Data collection was carried out on 29-04-2019 from 11:33:27 to 11:43:04 with 100 data received. Node 1 and node 2 placed at the top and node 3 placed at the ground of the parking area. In node 1 and 2 the data showed that the delay range is 4-8 seconds, while at node 3 the data shows that the delay range is 50 seconds because the internet connection is unstabled and blocked by the building, which made the data in node 3 delay quite a lot and produce the average air quality is relatively moderate as in the ISPU table which is 50-100ppm (see Table 5).

**TABLE 5.**  
**Data of Node in Indoor Parking Area**

No.	Time	Node	Temperature (°C)	Humidity (%)	Gas (ppm)
1.	11:33:27	1	32	36	234
2.	11:33:31	2	31	53	122
3.	11:33:40	3	32	43	123
4.	11:33:44	1	32	53	121
5.	11:34:01	2	33	36	234
6.	11:34:05	3	33	44	118
7.	11:34:19	1	32	53	144
8.	11:34:42	2	33	36	226
9.	11:34:43	3	33	36	234
10.	11:34:50	1	32	53	246
11.	11:34:03	2	33	36	144
12.	11:35:06	3	32	53	121
13.	11:35:08	1	32	47	127

Data analysis at third location was carried out in the indoor parking area of the Sriwijaya State Polytechnic Public Facilities. The indoor parking area caused only a few data obtained from each node. It because there are obstacles at that location. The obstacles caused the data sent and received on the server to be slightly hampered, because when the data sent to the server passes through the obstacles, there are some datas that have been hitted and absorbed by the obstacles.

#### **5. CONCLUSION**

This paper can be concluded that the longer the irradiation of sunlight to earth, the higher the air temperature is obtained so that the temperature at the outdoor parking area is higher than the indoor parking area. The humidity level that occurs in the indoor parking area is higher than the outdoor parking area because the low air

temperature slows evaporation of water so that the water vapor contained in the place is extremely. The CO gas level is obtained from the number of vehicles in the location. The many of vehicles, the higher the intensity of rainfall and CO gas levels in the area. The process of sending data in a location without obstacles is sent and received properly without interference. More effective and efficient data transmission causes the data obtained to be more accurate. However, the process of sending data in a location with obstacles is blocked due to the existence of a building that limits the sending of data between nodes and servers. The inhibition of sending data to the server is caused by the presence of delay, throughput and absorption or collision of data on the obstacles. So that the data that is read is still not accurate.

## REFERENCES

- [1] M. F. Othman and K. Shazali, "Wireless sensor network applications: A study in environment monitoring system," *Procedia Eng.*, vol. 41, pp. 1204–1210, 2012.
- [2] K. Sarammal and R. A. Roseline, "A Review: Wireless Sensor Networks and Its Application, Platforms, Standards and Tools," *Int. J. Comput. Trends Technol.*, vol. 4, no. 8, pp. 2905–2911, 2013.
- [3] P. Y. Dattatraya and J. Agarkhed, "A Review on Various Issues and Applications in Wireless Sensor Networks," *Int. J. Sci. Res.*, vol. 4, no. 11, pp. 2518–2522, 2015.
- [4] J. Yick, B. Mukherjee, and D. Ghosal, "Wireless sensor network survey," *Comput. Networks*, vol. 52, no. 12, pp. 2292–2330, 2008.
- [5] W. Li and W. Shen, "Journal of Network and Computer Applications Swarm behavior control of mobile multi-robots with wireless sensor networks," *J. Netw. Comput. Appl.*, vol. 34, no. 4, pp. 1398–1407, 2011.
- [6] G. Simon *et al.*, "Sensor network-based countersniper system," p. 1, 2005.
- [7] M. Castillo-Effen, D. H. Quintela, R. Jordan, W. Westhoff, and W. Moreno, "Wireless sensor networks for flash-flood alerting," pp. 142–146, 2005.
- [8] GaoT1, "Vital Signs Monitoring and Patient Tracking Over a Wireless Network (outra vers {ã}o)," vol. 27, no. 1, 2005.
- [9] K. Lorincz, D. J. Malan, T. R. F. Fulford-jones, A. Clavel, M. Welsh, and S. Moulton, "Sensor Networks for," *Ieee Cs*, 2004.
- [10] G. Werner-Allen *et al.*, "Deploying a wireless sensor network on an active volcano," *IEEE Internet Comput.*, vol. 10, no. 2, pp. 18–25, 2006.
- [11] V. Garg and M. Jhamb, "A Review of Wireless Sensor Network on Localization Techniques," *Int. J. Eng. Trends Technol.*, vol. 4, no. April, pp. 1049–1053, 2013.
- [12] A. Mainwaring, J. Polastre, R. Szewczyk, and D. Culler, "Wireless Sensor Network fot Habitat Monitoring.pdf."
- [13] A. Ramos, F. Riquelme, and F. Garcia, "Wireless Sensor Networks for Environmental Monitoring in Precision Viticulture," *Csbe-Scgab.Ca*, pp. 1–9, 2010.
- [14] H. Liu, S. Member, H. Darabi, P. Banerjee, and J. Liu, "Survey of Wireless Indoor Positioning Techniques and Systems," vol. 37, no. 6, pp. 1067–1080,

- 2007.
- [15] N. Habibie *et al.*, “CO 2 Monitoring System for Prototype of Building Air Quality Management Using,” vol. 2, no. December, pp. 49–60, 2016.
  - [16] P. Morreale, F. Qi, and P. Croft, “A Green Wireless Sensor Network for Environmental Monitoring and Risk Identification,” vol. x, no. x, 2010.
  - [17] G. Martinović and J. Simon, “Greenhouse microclimatic environment controlled by a mobile measuring station,” *NJAS - Wageningen J. Life Sci.*, vol. 70, pp. 61–70, 2014.
  - [18] W. Li and W. Shen, “Swarm behavior control of mobile multi-robots with wireless sensor networks,” *J. Netw. Comput. Appl.*, vol. 34, no. 4, pp. 1398–1407, 2011.
  - [19] S. U. Zagade and R. S. Kawitkar, “Wireless Sensor Network for Greenhouse,” vol. 2, no. 3, pp. 130–133, 2012.
  - [20] P. Sharma, “Wireless Sensor Networks for Environmental Monitoring,” pp. 3–4, 2010.
  - [21] A. Pawlowski, J. L. Guzmán, F. Rodríguez, M. Berenguel, J. S. And, and S. Dormido, “Study of event-based sampling techniques and their influence on greenhouse climate control with Wireless Sensors Network,” *Intech*, vol. i, no. tourism, p. 13, 2016.
  - [22] S. János and G. Martinović, “WSN Implementation in the Greenhouse Environment Using Mobile Measuring Station,” vol. 1, no. 1, pp. 41–48, 2010.
  - [23] A. Rodi??, D. Kati??, and G. Mester, “Ambient intelligent robot-sensor networks for environmental surveillance and remote sensing,” *SISY 2009 - 7th Int. Symp. Intell. Syst. Informatics*, pp. 39–44, 2009.
  - [24] T. S. Hong, D. Nakhaeinia, and B. Karasfi, “Application of Fuzzy Logic in Mobile Robot Navigation.”
  - [25] “A\_Comprehensive\_Study\_on\_Glowworm\_Swarm.”
  - [26] A. Ali, Y. Ming, S. Chakraborty, and S. Iram, “A comprehensive survey on real-time applications of WSN,” *Futur. Internet*, vol. 9, no. 4, 2017.
  - [27] L. A. Zadeh, “Soft computing and fuzzy logic,” *IEEE Softw.*, vol. 11, no. 6, pp. 48–56, 1994.
  - [28] S. Nurmaini, “Low-cost robotic sensor networks platform for air quality monitoring,” *WIT Trans. Built Environ.*, vol. 145, no. April 2014, pp. 461–468, 2014.
  - [29] J. H. Ryu, M. Irfan, and A. Reyaz, “A Review on Sensor Network Issues and Robotics,” *J. Sensors*, vol. 2015, pp. 1–14, 2015.
  - [30] G. S. Sara and D. Sridharan, “Routing in mobile wireless sensor network: A survey,” *Telecommun. Syst.*, vol. 57, no. 1, pp. 51–79, 2014.
  - [31] S. János, G. Martinović, and I. Matijevics, “WSN implementation in the greenhouse environment using mobile measuring station,” *Int. J. Electr. Comput. Eng. Syst.*, vol. 1, no. 1, pp. 37–44, 2010.
  - [32] W. V. Shi, “Sensors Applied in Healthcare Environments,” *J. Comput. Commun.*, vol. 04, no. 05, pp. 99–106, 2016.
  - [33] M. Al-Obaidy and A. Ayesh, “Energy efficient algorithm for swarmed sensors networks,” *Sustain. Comput. Informatics Syst.*, vol. 5, pp. 54–63, 2015.
  - [34] V. Novák, I. Perfilieva, and J. Močkoř, “Mathematical Principles of Fuzzy Logic,” *Math. Princ. Fuzzy Log.*, vol. 517, no. 0, p. 6221, 2011.





- [35] A. Meylani et al., “Different Types of Fuzzy Logic in Obstacles Avoidance of Mobile Robot,” Proc. 2018 Int. Conf. Electr. Eng. Comput. Sci. ICECOS 2018, vol. 17, pp. 93–100, 2019.
- [36] S. Nurmaini, Saparudin, B. Tutuko, and P. Aditya Putra, “Pattern recognition approach for swarm robots reactive control with fuzzy-kohonen networks and particle swarm optimization algorithm,” J. Telecommun. Electron. Comput. Eng., vol. 8, no. 3, 2016.
- [37] E. Hashemi, M. Ghaffari Jadidi, and N. Ghaffari Jadidi, “Model-based Pifuzzy control of four-wheeled omni-directional mobile robots,” Rob. Auton. Syst., vol. 59, no. 11, pp. 930–942, 2011.
- [38] J. Aladi, C. Wagner, and J. Garibaldi, “Type-1 or Interval Type-2 Fuzzy Logic Systems-On the Relationship of the Amount of Uncertainty and FOU Size,” Fuzzy Syst. (FUZZ-IEEE), IEEE Int. Conf., pp. 1–8, 2014.
- [39] P. Dostál, “Forecasting of Time Series with Fuzzy Logic,” Adv. Intell. Syst. Comput., vol. 210, pp. 155–161, 2013.
- [40] D. W. D. Wu, J. M. Mendel, and J. J. J. Joo, “Linguistic summarization using IF-THEN rules,” Fuzzy Syst. (FUZZ), 2010 IEEE Int. Conf., no. 213, 2010.
- [41] R. K. Ramachandran and S. Berman, “The Effect of Communication Topology on Scalar Field Estimation by Networked Robotic Swarms,” pp. 3886–3893, 2017.
- [42] N. Bulusu, J. Heidemann, and D. Estrin, “GPS-less low cost outdoor localization for very small devices. IEEE Personal Communications, 7(5),” IEEE Pers. Commun. Mag., vol. 7, no. 5, pp. 28–34, 2000.