

University of Nebraska - Lincoln

DigitalCommons@University of Nebraska - Lincoln

Nebraska Tractor Tests

Tractor Test and Power Museum, The Lester F. Larsen

2017

Tractor Test 2174: John Deere 9620RX Diesel

Nebraska Tractor Test Laboratory

Follow this and additional works at: <https://digitalcommons.unl.edu/tractormuseumlit>



Part of the [Energy Systems Commons](#), [History of Science, Technology, and Medicine Commons](#), [Other Mechanical Engineering Commons](#), [Physical Sciences and Mathematics Commons](#), [Science and Mathematics Education Commons](#), and the [United States History Commons](#)

This Article is brought to you for free and open access by the Tractor Test and Power Museum, The Lester F. Larsen at DigitalCommons@University of Nebraska - Lincoln. It has been accepted for inclusion in Nebraska Tractor Tests by an authorized administrator of DigitalCommons@University of Nebraska - Lincoln.

NEBRASKA OECD TRACTOR TEST 2174-SUMMARY 1088

JOHN DEERE 9620RX DIESEL

18 SPEED

POWER TAKE-OFF PERFORMANCE

Power HP (kW)	Crank shaft speed rpm	Diesel Consumption		D.E.F. Consumption		Mean Atmospheric Conditions
		Gal/hr (l/h)	lb/hp.hr (kg/kW.h)	Hp.hr/gal (kW/h/l)	Gal/hr (l/h)	
MAXIMUM POWER AND FUEL CONSUMPTION						
SEE NOTE 3 - PAGE 2						
Rated Engine Speed—(PTO speed—1109 rpm)						
315.14 (235.00)	2099	19.39 (73.40)	0.431 (0.262)	16.25 (3.20)	0.93 (3.54)	Fuel used during active exhaust regeneration-2.75 gal (10.42 l) (see note 2, p.2)
Standard Power Take-off Speed(1000 rpm)						
344.75 (257.08)	1895	19.84 (75.11)	0.403 (0.245)	17.38 (3.42)	0.91 (3.44)	
Maximum Power (1 hour)						
357.89 (266.88)	1650	19.39 (73.38)	0.379 (0.231)	18.46 (3.64)	0.97 (3.67)	

VARYING POWER AND FUEL CONSUMPTION

315.14 (235.00)	2099	19.39 (73.40)	0.431 (0.262)	16.25 (3.20)	0.93 (3.54)	Air temperature
274.04 (204.35)	2149	17.89 (67.73)	0.457 (0.278)	15.32 (3.02)	0.89 (3.37)	74°F (24°C)
205.64 (153.35)	2150	14.62 (55.35)	0.498 (0.303)	14.06 (2.77)	0.74 (2.80)	Relative humidity
137.38 (102.44)	2150	11.64 (44.06)	0.593 (0.361)	11.80 (2.32)	0.57 (2.16)	56%
68.50 (51.08)	2150	8.85 (33.49)	0.905 (0.550)	7.74 (1.53)	0.33 (1.25)	Barometer
1.30 (0.97)	2150	6.33 (23.96)	34.033 (20.702)	0.21 (0.04)	0.20 (0.76)	28.68" Hg (97.12 kPa)

Maximum Torque - 1174 lb-ft (1592 Nm) at 1550 rpm

Maximum Torque Rise -48.9%

Torque rise at 1679 engine rpm -42%

Power increase at 1650 engine rpm -13.6%

DRAWBAR PERFORMANCE (Unballasted) FUEL CONSUMPTION CHARACTERISTICS

Power Hp (kW)	Drawbar pull lbs (kN)	Speed mph (km/h)	Crank- shaft speed rpm	Slip %	Fuel Consumption lb/hp.hr (kg/kW.h)	D.E.F. Consumption Hp.hr/gal (kW/h/l)	D.E.F. Consumption lb/hp.hr (kg/kW.h)	Temp. °F (°C) cool- ing med	Air dry bulb	Barom. inch Hg (kPa)
Power at Rated Engine Speed—7th Gear- Manual mode										
494.32 (368.61)	37737 (167.86)	4.91 (7.90)	2100	4.6	0.451 (0.274)	15.54 (3.06)	0.017 (0.010)	212 (100)	54 (12)	28.88 (97.80)
75% of Pull at Rated Engine Speed—7th Gear- Manual mode										
390.52 (291.21)	28295 (125.86)	5.18 (8.33)	2173	2.7	0.457 (0.278)	15.33 (3.02)	0.022 (0.013)	210 (99)	72 (22)	28.84 (97.66)
50% of Pull at Rated Engine Speed—7th Gear- Manual mode										
267.79 (199.69)	18846 (83.83)	5.33 (8.58)	2201	1.2	0.493 (0.300)	14.20 (2.80)	0.031 (0.019)	206 (97)	74 (23)	28.83 (97.63)
75% of Pull at Reduced Engine Speed—5.3 mph (8.6 km/h)-Auto mode										
390.67 (291.32)	28401 (126.33)	5.16 (8.30)	1584	2.7	0.414 (0.252)	16.90 (3.33)	0.024 (0.015)	208 (98)	72 (22)	28.85 (97.70)
50% of Pull at Reduced Engine Speed—5.3 mph (8.6 km/h)-Auto mode										
268.39 (200.13)	18763 (83.46)	5.36 (8.63)	1318	1.2	0.421 (0.256)	16.65 (3.28)	0.027 (0.016)	205 (96)	75 (24)	28.81 (97.56)

Location of tests: Nebraska Tractor Test Laboratory, University of Nebraska, Lincoln, Nebraska 68583-0832

Dates of tests: April 12 - 19, 2017

Manufacturer: John Deere Tractor Works, 3500 East Donald St., P.O. Box 270, Waterloo Ia, 50704-0270

CONSUMABLE Fluids, OIL and TIME: Fuel No. 2 Diesel **Specific gravity converted to 60°/60°F (15°/15°C)** 0.8411 **Fuel weight** 7.003 lbs/gal (0.839 kg/l) **Diesel Exhaust Fluid (DEF)** 32% aqueous urea solution **DEF weight** 9.071 lbs/gal (1.087 kg/l) **Oil SAE 10W-30 API service classification** CJ-4 **Transmission, hydraulic and final drive lubricant** John Deere Hy-Gard fluid **Total time engine was operated:** 26.5 hours

ENGINE: Make Cummins Diesel **Type** six cylinder vertical with turbocharger, air to air aftercooler and D.E.F. (diesel exhaust fluid) exhaust treatment **Serial No.** *79941414* **Crankshaft** lengthwise **Rated engine speed** 2100 **Bore and stroke** 5.394" x 6.654" (137.0 mm x 169.0 mm) **Compression ratio** 17.2 to 1 **Displacement** 912 cu in (14948 ml) **Starting system** 12 volt **Lubrication** pressure **Air cleaner** two paper elements and aspirator **Oil filter** one full flow cartridge **Oil cooler** engine coolant heat exchanger for crankcase oil, radiator for transmission/hydraulic oil also feeding front and rear axles **Fuel filter** two paper cartridges **Fuel cooler** radiator for returned fuel **Exhaust** DOC (diesel oxidation catalyst), SCR (selective catalyst reduction) and regenerative DPF (diesel particulate filter) integrated within a vertical muffler **Cooling medium temperature control** thermostat and variable speed fan

ENGINE OPERATING PARAMETERS: Fuel rate: Stationary PTO operation (395 engine hp) 137.3 - 148.8 lb/h (62.3 - 67.5 kg/h), Drawbar operations (620 engine hp) 209.9 - 226.6 lb/h (95.2 - 102.8 kg/h) **High idle:** 2215 - 2265 rpm (2125 - 2175 rpm with PTO engaged) **Turbo boost:** (620 engine hp) nominal 26.1 - 30.0 psi (180 - 207 kPa) as measured 28.5 psi (197 kPa)

CHASSIS: Type 4WD with rubber tracks **Serial No.** *1RW9620RKG8P01552* **Track width** rear 88.0" (2235 mm) front 88.0" (2235 mm) **Wheelbase** 163.5" (4154 mm) **Length of track on ground** 72.4" (1839 mm) **Hydraulic control system** direct engine drive **Transmission** selective gear fixed ratio with full range operator controlled power shift **Nominal travel speeds mph (km/h)** first 2.50 (4.03) second 3.08 (4.96) third 3.41 (5.48) fourth 3.81 (6.13) fifth 4.19 (6.75) sixth 4.69 (7.55) seventh 5.18 (8.34) eighth 5.76 (9.27) ninth 6.38 (10.27) tenth 7.09 (11.41) eleventh 7.84 (12.61) twelfth 8.71 (14.02) thirteenth 9.64 (15.52) fourteenth 10.73 (17.26)

DRAWBAR PERFORMANCE
(Unballasted at 2100 engine rpm, Manual mode)

MAXIMUM POWER IN SELECTED GEARS

Power Hp (kW)	Drawbar pull lbs (kN)	Speed mph (km/h)	Crank- shaft speed rpm	Slip %	Fuel Consumption lb/hp.hr (kg/kW.h)	Hp.hr/gal (kW.h/l)	D.E.F Consumption lb/hp.hr (kg/kW.h)	Temp. °F(°C) cool- ing med	Air dry bulb	Barom. inch Hg (kPa)
					2nd Gear					
353.88 (263.88)	48485 (215.67)	2.74 (4.41)	2103	10.8	0.490 (0.298)	14.29 (2.82)	0.025 (0.015)	207 (97)	60 (16)	28.90 (97.87)
					3rd Gear					
383.56 (286.02)	47364 (210.68)	3.04 (4.89)	2099	10.2	0.474 (0.288)	14.77 (2.91)	0.024 (0.014)	207 (97)	63 (17)	28.88 (97.80)
					4th Gear					
410.02 (305.75)	44772 (199.16)	3.44 (5.53)	2099	9.0	0.471 (0.286)	14.88 (2.93)	0.022 (0.014)	210 (99)	65 (19)	28.90 (97.87)
					5th Gear					
438.43 (326.93)	42782 (190.30)	3.84 (6.18)	2100	7.5	0.464 (0.282)	15.09 (2.97)	0.019 (0.012)	211 (99)	69 (20)	28.87 (97.77)
					6th Gear					
479.04 (357.22)	41350 (183.93)	4.35 (6.99)	2100	6.8	0.462 (0.281)	15.15 (2.98)	0.016 (0.010)	211 (99)	65 (19)	28.88 (97.80)
					7th Gear					
494.32 (368.61)	37737 (167.86)	4.91 (7.90)	2100	4.6	0.451 (0.274)	15.54 (3.06)	0.017 (0.010)	212 (100)	54 (12)	28.88 (97.80)
					8th Gear					
499.81 (372.71)	33999 (151.24)	5.52 (8.88)	2100	3.7	0.439 (0.267)	15.97 (3.15)	0.016 (0.010)	211 (99)	53 (12)	28.87 (97.77)
					9th Gear					
497.14 (370.72)	30287 (134.72)	6.16 (9.91)	2100	2.9	0.445 (0.271)	15.72 (3.10)	0.016 (0.010)	211 (99)	53 (12)	28.88 (97.80)
					10th Gear					
499.35 (372.37)	27210 (121.04)	6.88 (11.07)	2100	2.3	0.446 (0.272)	15.69 (3.09)	0.017 (0.011)	211 (99)	52 (11)	28.92 (97.93)
					11th Gear					
498.74 (371.91)	24481 (108.90)	7.64 (12.30)	2099	1.8	0.447 (0.272)	15.67 (3.09)	0.017 (0.010)	211 (99)	54 (12)	28.90 (97.87)
					12th Gear					
500.61 (373.30)	22014 (97.92)	8.53 (13.72)	2099	1.4	0.444 (0.270)	15.79 (3.11)	0.017 (0.010)	212 (100)	54 (12)	28.90 (97.87)

fifteenth 13.26 (21.34) sixteenth 16.32 (26.26) seventeenth 20.04 (32.25) eighteenth 24.67 (39.70) reverse 2.50 (4.03), 3.41 (5.48), 3.81 (6.13), 5.18 (8.34), 5.76 (9.27), 7.84 (12.61) **Clutch** wet multiple disc hydraulically actuated by foot pedal **Brakes** wet multiple disc hydraulically actuated by foot pedal **Steering** hydrostatic and articulated **Power take-off** 1000 rpm at 1895 engine rpm **Unladen tractor mass** 57570lb (26113 kg)

REPAIRS AND ADJUSTMENTS: No repairs or adjustments.

NOTE 1: This tractor has a driveline protection system that limits the maximum engine torque in gears 1 through 5.

NOTE 2. The manufacturer declares that the average time between active regenerations is 60 hours.

NOTE 3. In stationary PTO operation, this model operates in a derated power mode. With stationary PTO operation, using FieldCruise™, an isochronous governor is utilized. All PTO tests were conducted with FieldCruise™ engaged.

REMARKS: All test results were determined from observed data obtained in accordance with official OECD, SAE and Nebraska test procedures. The performance figures on this summary were taken from a test conducted under the OECD Code 2 test procedure.

We, the undersigned, certify that this is a true and correct report of official Tractor Test No. **2174**, Nebraska Summary 1088, June 12, 2017.

Roger M. Hoy
Director

M.F. Kocher
P.J. Jasa
S.K. Pitla
Board of Tractor Test Engineers

TRACTOR SOUND LEVEL WITH CAB

dB(A)

At no load in 6th gear	72.3
Transport speed-no load-18th gear	75.0
Bystander in 17th gear	90.4

TRACKS AND WEIGHT

Rear tracks - no & size
Front tracks - no & size
Height of drawbar
Static weight with operator- Rear
- Front
- Total

Tested Without Ballast

2 x 30.0 in (760 mm)
2 x 30.0 in (760 mm)
21.0 in (545 mm)
25680 lb (11648 kg)
32065 lb (14544 kg)
57745 lb (26192 kg)

DRAWBAR PERFORMANCE
UNBALLASTED - AUTO MODE
(Loads based on 2100 engine rpm manual mode performance runs)
DRAWBAR POWER AT SELECTED TRAVEL SPEEDS

Power Hp (kW)	Drawbar pull lbs (kN)	Speed mph (km/h)	Crank- shaft speed rpm	Slip %	Fuel Consumption		D.E.F. Consumption	Temp. °F (°C)		Barom. inch Hg (kPa)
					lb/hp.hr (kg/kW.h)	Hp.hr/gal (kW.h/l)	lb/hp.hr (kg/kW.h)	cool- ing med	Air dry bulb	
4.7 mph (7.6 km/h)										
479.45 (357.52)	40995 (182.35)	4.39 (7.07)	1724	6.4	0.424 (0.258)	16.52 (3.25)	0.020 (0.012)	210 (99)	67 (19)	28.88 (97.80)
5.2 mph (8.4 km/h)										
495.59 (369.56)	37526 (166.92)	4.96 (7.97)	1719	4.6	0.420 (0.255)	16.68 (3.29)	0.022 (0.013)	212 (100)	54 (12)	28.90 (97.87)
5.7 mph (9.2 km/h)										
497.75 (371.17)	34142 (151.87)	5.47 (8.80)	1694	3.8	0.407 (0.248)	17.21 (3.39)	0.021 (0.013)	209 (98)	53 (12)	28.89 (97.83)
6.3 mph (10.2 km/h)										
496.24 (370.04)	30416 (135.29)	6.12 (9.85)	1699	2.8	0.409 (0.249)	17.13 (3.37)	0.021 (0.013)	209 (98)	53 (12)	28.90 (97.87)
7.1 mph (11.4 km/h)										
499.40 (372.40)	27195 (120.97)	6.89 (11.08)	1708	2.2	0.406 (0.247)	17.24 (3.40)	0.022 (0.013)	209 (98)	52 (11)	28.91 (97.90)
7.8 mph (12.6 km/h)										
497.91 (371.29)	24435 (108.69)	7.64 (12.30)	1705	1.8	0.407 (0.248)	17.21 (3.39)	0.021 (0.013)	210 (99)	54 (13)	28.89 (97.83)
8.7 mph (14.0 km/h)										
499.27 (372.30)	21981 (97.77)	8.52 (13.71)	1704	1.5	0.410 (0.250)	17.07 (3.36)	0.022 (0.013)	212 (100)	53 (12)	28.88 (97.80)

DRAWBAR PERFORMANCE
(Unballasted at 1800 ENGINE RPM, Manual mode)
MAXIMUM POWER IN SELECTED GEARS

Power Hp (kW)	Drawbar pull lbs (kN)	Speed mph (km/h)	Crank- shaft speed rpm	Slip %	Fuel Consumption lb/hp.hr (kg/kW.h)	Hp.hr/gal (kW.h/l)	D.E.F Consumption lb/hp.hr (kg/kW.h)	Temp.°F(°C) cool- ing med	Air dry bulb	Barom. inch Hg (kPa)	
360.23 (268.62)	53349 (237.31)	2.53 (4.07)	2024	14.0	2nd Gear 0.499 (0.304)		14.03 (2.76)	0.025 (0.015)	207 (97)	56 (13)	28.92 (97.93)
386.78 (288.42)	49823 (221.62)	2.91 (4.68)	2059	12.3	3rd Gear 0.482 (0.293)		14.52 (2.86)	0.024 (0.014)	208 (98)	64 (18)	28.90 (97.87)
418.85 (312.34)	48537 (215.90)	3.24 (5.21)	2032	11.7	4th Gear 0.476 (0.289)		14.72 (2.90)	0.022 (0.013)	209 (98)	65 (18)	28.89 (97.83)
442.92 (330.29)	46690 (207.69)	3.56 (5.73)	2024	10.9	5th Gear 0.475 (0.289)		14.73 (2.90)	0.022 (0.013)	212 (100)	66 (19)	28.88 (97.80)
486.38 (362.69)	45742 (203.47)	3.99 (6.42)	2003	9.9	6th Gear 0.473 (0.288)		14.81 (2.92)	0.019 (0.011)	213 (100)	66 (19)	28.88 (97.80)
509.60 (380.01)	44387 (197.44)	4.31 (6.93)	1935	9.2	7th Gear 0.460 (0.280)		15.24 (3.00)	0.021 (0.013)	215 (101)	66 (19)	28.89 (97.83)
529.51 (394.86)	42179 (187.62)	4.71 (7.58)	1858	7.0	8th Gear 0.442 (0.269)		15.84 (3.12)	0.019 (0.012)	213 (101)	64 (18)	28.87 (97.77)
533.81 (398.06)	38977 (173.38)	5.14 (8.27)	1800	5.4	9th Gear 0.433 (0.263)		16.18 (3.19)	0.020 (0.012)	212 (100)	57 (14)	28.89 (97.83)
540.61 (403.13)	35111 (156.18)	5.78 (9.29)	1800	4.4	10th Gear 0.426 (0.259)		16.44 (3.24)	0.020 (0.012)	212 (100)	56 (13)	28.88 (97.80)
543.50 (405.29)	31649 (140.78)	6.44 (10.36)	1800	3.5	11th Gear 0.423 (0.258)		16.54 (3.26)	0.020 (0.012)	212 (100)	54 (12)	28.88 (97.80)
549.55 (409.80)	28573 (127.10)	7.21 (11.60)	1800	2.8	12th Gear 0.420 (0.255)		16.69 (3.29)	0.020 (0.012)	212 (100)	59 (15)	28.87 (97.77)
542.70 (404.69)	25346 (112.74)	8.03 (12.92)	1799	2.2	13th Gear 0.424 (0.258)		16.53 (3.26)	0.021 (0.013)	212 (100)	59 (15)	28.87 (97.77)

Lugging ability in 11th gear

Crankshaft speed rpm	2101	2000	1899	1799	1700	1600	1401	1101
Pull-lbs (kN)	24421 (108.63)	27051 (120.33)	29600 (131.67)	31589 (140.51)	33339 (148.30)	34610 (153.95)	34278 (152.47)	28149 (125.21)
Increase in pull%	0	11	21	29	37	42	40	15
Power-Hp (kW)	496.87 (370.52)	520.96 (388.48)	539.09 (402.00)	542.69 (404.68)	538.12 (401.27)	524.15 (390.85)	454.91 (339.22)	298.05 (222.26)
Speed-mpH (km/h)	7.63 (12.28)	7.23 (11.63)	6.83 (10.99)	6.44 (10.36)	6.05 (9.74)	5.68 (9.14)	4.98 (8.01)	3.97 (6.39)
Slip %	2.1	2.7	2.9	3.4	4.0	4.3	4.1	2.7

HYDRAULIC PERFORMANCE

CATEGORY: 4N/4

Quick Attach: Yes

OECD Static test

Maximum force exerted through whole range:

Category 4N lift cylinders
15648 lbs(69.6 kN) (1 x 90 mm and 1x100 mm)
20965 lbs(93.3 kN) (2 x 110 mm)

Category 4
15501 lbs(69.0 kN) (1 x 90 mm and 1x100 mm)
20527 lbs(91.3 kN) (2 x 110 mm)

Base pump Tandem pump
three outlet sets combined

i) Sustained pressure at compensator cutoff:

2901 psi (200 bar) 2933 psi (202 bar)

ii) Pump delivery rate at minimum pressure and rated engine speed:

60.0 GPM (227.3 l/min) 56.9 GPM (215.4 l/min)

Combined flow:

116.9 GPM (442.7 l/min)

iii) Pump delivery rate at maximum

hydraulic power:

60.5 GPM (229.2 l/min) 57.2 GPM (216.5 l/min)

Delivery pressure:

2500 psi (172 bar) 2403 psi (166 bar)

Power:

88.3 HP (65.9 kW) 80.2 HP (59.8 kW)

single outlet set

3/4" couplers 1/2" couplers

i) Sustained pressure at compensator cutoff:

2856 psi (197 bar) 2887 psi (199 bar)

ii) Pump delivery rate at minimum pressure and rated engine speed:

43.1 GPM (163.2 l/min) 37.2 GPM (141.0 l/min)

iii) Pump delivery rate at maximum

hydraulic power:

42.5 GPM (160.9 l/min) 35.7 GPM (135.0 l/min)

Delivery pressure:

2226 psi (153 bar) 2204 psi (152 bar)

Power:

55.2 HP (41.2 kW) 45.9 HP (34.2 kW)

Category 4N

inch mm

	inch	mm	inch	mm
A	30.7	780	29.9	760
B	19.7	500	19.7	500
C	34.8	885	34.8	885
D	28.7	730	28.7	730
E	18.7	475	18.7	475
F	12.5	318	12.5	318
G	33.1	842	33.1	842
*G'	19.5	495	19.5	495
H	2.2	57	2.2	57
I	28.8	733	28.8	733
J	20.6	524	20.6	524
K	30.9	785	30.9	785
L	52.8	1342	52.8	1342
*L'	58.7	1491	59.6	1515
M	14.7	374	14.7	374
N	45.6	1159	45.6	1159
O	9.0	230	9.0	230
P	47.6	1210	47.6	1210
Q	40.6	1032	40.4	1027
R	49.6	1260	48.6	1260

*G' to undercarriage pivot point

*L' to Quick Attach ends

HITCH DIMENSIONS AS TESTED—NO LOAD

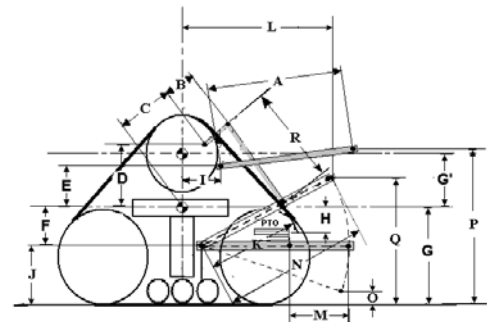

JOHN DEERE 9620RX DIESEL