

An Algorithm of Setting the Weights of a Neural Network Controller

Dmitro P. Kucherov and Volodimir N. Dikhtyarenko
National Aviation University, Kiev, Ukraine
Email: d_kucherov@ukr.net, vosha@i.ua

Andrei M. Kozub
National University of Defence of Ukraine, Kiev, Ukraine
Email: kozubtanja@rambler.ru

Abstract—The paper considers a novel method of setting a neural networks controller that takes part in the control of a dynamic plant with unknown parameters. The uncertainties are usually overcome by using sliding mode for controller with a switching input signal. Consequently, as a result the obtained system not sufficiently reliable by reason of high frequency switching control signal and long processing time. To remove this deficiency, the paper considers the neural network controller that is set by means of its learning based on the results of the latest testing. The characteristic feature of the algorithm is its ability to fix the faulty control situations introduced into the learning algorithm, thus giving it the properties of self-learning. The suggested algorithm provides the control quasi-optimality on time and accuracy in controlling a dynamic object. Finally, numerical examples are presented to demonstrate system efficiency for developed method

Index Terms—control system, synthesis algorithm, neural network, switching element

I. INTRODUCTION

Creating control systems with a neural networks controller in the control loop for controlling dynamic objects has been widely used recently. The major advantage of such systems is their ability to provide the required quality of control under varying operating conditions or varying parameters of the object caused by varying load on the actuators of the system. Such operating conditions may occur in aircraft control devices, robotics, nuclear reactors, etc.

The control system with neural network controller is a sort of information-control system which includes computing devices, controllers, actuators, and other items that can be used for automatic control of a dynamic object whose mathematical model can be represented by a system of differential equations.

The most common requirements to a control system are accuracy and time of task execution by the object under control. These parameters depend essentially on the payload, actuator and control methods that are used, as well as on the operating conditions.

There are methods based on the full information about the actuator and load parameters, and adaptive approaches which enable the system to operate when its parameters vary in a wide range or allow lack of a priori information about these parameters that is the most common case. The sharp change of parameters and disturbances misbalances the control system, which operates quite well under average designed conditions, and the goal of control may not be attained at the same time. Pre-eminently in such cases the adaptive approaches should be used

An approach based on constructing neural network controller can be referred to these approaches. It provides correction of the controller parameters in order to optimize its performance under current operating conditions. The advantages of this type of control can be the lack of a reference model, the ability to operate with the perturbing effects of different nature and ease of technical implementation. In this regard, the problem of synthesis of dynamic plant neural network control in the condition of parametric variation of the actuator, load and disturbing factors is seen as relevant.

Known approaches of the adaptive systems implementation are based on the methods of adaptive systems constructing, such as methods of constructing extreme and neural network systems. The feasibility of using a particular method of system construction is determined by the characteristics of the control plant and its operation's conditions. Thus, in the case of extreme dependence of the object parameters of the control signal and continuous parametric variation of the equipment, it is possible to use extreme methods of control. In those systems where extreme performance is not detected, it is advisable to use methods that are based on the principles of regulation by the neural network.

II. PREVIOUS RESEARCH

In contrast to classical approaches to creating high accuracy control systems that is based on the theory of invariance and optimality and considered in [1], whose main task is to achieve the minimum error on an arbitrary

time interval, we will show the problem with an additional constraint to the system's operation time.

Most of the development in this area related to the construction of the loop controller with neural networks [2]-[7], based on the results of [8], [9], that show the performance of Adaline (Adaptive linear neuron) system for control of dynamic plants. Adaline system consists of amplifiers with variable transmission coefficients (weights, tuning parameters) that are configured during the operation, and the signal adder. The main idea of the parameter vector correction is based on results of the latest test and their application to the reference function of the Adaline system's decision block. By comparing the results obtained and the expected responses the decision about parameter vector correction is made. The main disadvantage of this method is duration and accuracy of input operation by dynamic plant after setting. The setting method is essentially based on the differences that exist in the decision function of the reference model and Adaline system. The presence of these differences defines the magnitude and direction of change of weights of weight coefficient change. On the other hand, it is necessary to carry out a small correction step that determines the duration of the whole process of setting to ensure the accuracy settings. This adjustment is made to parameters of the learning model, which does not include real dynamic properties of the control plant in the operating conditions. Thus, if the parameters differ from the reference model of the dynamic system, the desired accuracy and performance will not be achieved.

In [2], Adaline system is used for control of a nuclear reactor. The control unit consists of neural network controller and PID - controller as a reference model. PID-controller is used as a reference model to configure neural network controller (executed on the principles of system's Adaline construction building). PID controller's output data that in accordance with neural network controller's operation algorithm change its weight parameters is used to adjust the weight parameters of the neural network controller. When the reaction neural networks controller becomes the same as the output of PID-controller, PID-controller is off.

A low speed of weight parameters setting and the lack of both accuracy and speed of the proposed control system, in which the PID controller is used as a reference model for setting the controller with network, should be considered as disadvantages of this approach. The accuracy and speed of the system are considerably determined by the quality performance of PID controller and influence the speed of controller setting which requires time for learning.

The paper [3] shows the strategy for managing direct adaptation of the neural network for nonlinear systems with unknown parameters such as regression. It is assumed that the system is trained by minimizing the output values of the neural model. For systems with variable structure [4] assumes the use of a sliding mode to enhance the sustainable operation control system.

The method that allows creating and maintaining a predefined sliding motion in the phase space by adjusting

the parameters of the Adaline-type controller is considered in [5].

An algorithm with on-line training by fuzzy-neural networks of Takagi-Sugeno-Kang type with a scalar output offered in [6].

As it is shown in [7], in neural network control of dynamic plant it is possible to eliminate the need to use the sliding mode, which results not only in prolonging of the control process, but also provides a gentle treatment of the executive control at the expense of minimizing the number of switching control signal.

The purpose of this paper is a synthesis of algorithm for weight parameters setting of neural network controllers in the control loop of the dynamic plant possessing adequate indicators of the accuracy and speed in the absence of a reference model.

III. PROBLEM FORMULATION

The dynamic plant that described by a differential equation in the form is considered [10], [11]

$$\dot{x}(t) = Ax(t) + bu(t), \quad (1)$$

where $x(t) \in R^n$ - a vector of state variables, $u(t)$ - the control signal, and A - $n \times n$ matrix, and b - n -dimensional vector, i.e.

$$A = \begin{pmatrix} 0 & 1 & \dots & 0 \\ 0 & 0 & \dots & 0 \\ 0 & 0 & \dots & 1 \\ a_{n1} & a_{n2} & \dots & a_{nn} \end{pmatrix}, \quad b = \begin{pmatrix} 0 \\ 0 \\ \dots \\ k \end{pmatrix} \quad (2)$$

In (2), the coefficients $a_{n1}, a_{n2}, \dots, a_{nm}, k$ - defined by the parameters of the system that are unknown to the designer of the system. It is only assumed that the system (1), (2) doesn't have complex roots and the coefficients $a_{n1}, a_{n2}, \dots, a_{nm}, k$ may be in intervals

$$\underline{a}_{ni} \leq a_{ni} \leq \bar{a}_{ni}, \quad \underline{k} \leq k \leq \bar{k} \quad (3)$$

The boundaries $\underline{a}_{ni}, \bar{a}_{ni}, \underline{k}, \bar{k}$ are considered known.

It is also known that to the moment that associated with the start of the system, i.e. when $t=0$, the object is in a state $x(0)$. It is assumed that the state measurement is made of low-noise sensors, or they may be estimated with sufficient accuracy. The goal is to move the object from an initial state $x(0)$ to the final $x(t_k)$ for the minimum time $T \in [0, t_k]$.

IV. SIMULATION OF THE CONTROL ALGORITHM

In accordance with the requirements of the task, and introducing the assumption of known parameters, we assume that the control algorithm has to ensure optimal operation of the system over time due to the use of the control signal form $u(t) = \{+U, -U\}$, and its switching at some point of time, with the number of control intervals defined by the well-known theorem of n - intervals [12], [13]. We assume that in the conditions of the problem with uncertain parameters, the system has a close

operation mode, and the number of switching control signal should not significantly exceed n .

The operation mode of the system, having the number of switching control signal close to the optimum and providing the required quality control will be called quasi-optimal. In this case, the sliding mode control of a dynamic system is not provided.

As in [2, 3] controller according c_0 and $\Delta(t)$, $\dot{x}(t)$ calculates the value of a decision function $F(c, X(t))$, where $X(t)$ - a vector whose components are determined by a digital code of signals $\Delta(t) = x_3(t) - x(t)$ and $\dot{x}(t)$. A function $\text{sign } F(c, X(t))$ defines the sign of the control signal $u(t)$, which is formed by a switching element, namely

$$u(t) = \begin{cases} +U, & \text{if } F(c, X(t)) > 0, \\ -U, & \text{if } F(c, X(t)) < 0, \\ u(t-0), & \text{if } F(c, X(t)) = 0. \end{cases} \quad (4)$$

The switching element changes the voltage value from $+U$ to $-U$ and vice versa at the entrance of a dynamic plant by the law (4). In (4) the value of the manipulated variable $u(t)$ also remains equal to the previous value when the phase point is on the surface of the switching, that is, when $F(c, X(t)) = 0$. The function $F(c, X(t)) = 0$ in the phase space interpreted geometrically as surface switching, Fig. 1, which divides the phase space into sub-surface of opposite signs. Fig. 1 notations e_1, e_2, e_3 - phase space, U_+ - control action of the positive sign, U_- - control action of the negative sign, O - origin.

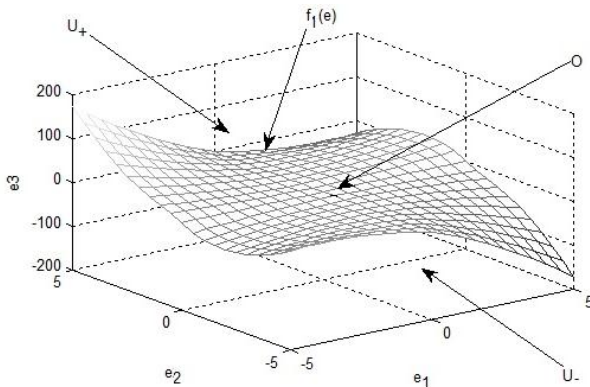

Figure 1. A view of function $F(\cdot)$ in space e_1, e_2, e_3 .

The signal $u(t)$ causes the object to move in the direction to reduce the error $\Delta(t)$, which corresponds to the position of the point O on Fig. 1.

The main difficulty of the approach is to determine the form of the function $F(\cdot)$. If you know the exact form of the mathematical model (1), (2) and $n \leq 3$, the function $F(\cdot)$ is obtained in an analytical form. In other cases, the function $F(\cdot)$ should either simplify the mathematical model of the process control, or build it as a linear model in relation to the measured coordinates $X(t)$.

While organizing the computational process, the effect of a finite precision should be eliminated, that manifests itself in an endless loop control in a neighbourhood of the origin. Eliminating of these cycles leads to the need to

introduce some of Ω_y in a neighbourhood of the origin, where the action of the control law (4) is stopped, we will be called the reachable area.

Uncertainty of object parameters (1), (2) implies an arbitrary set of weighting coefficients c the function $F(\cdot)$, which may lead to the following performance situations in the system:

1) *Sliding mode*

2) *Self-oscillation mode*

3) *ingress of an object in the range of permissible errors $|\Delta_i(t)| \leq \Delta^*$ in the required number of operations N^* control action $u(t)$.*

The first two situations are wrong, the latter is desirable.

The difference between error situations is performed by means of logic based on counting the number of switching of the switch-element and measuring error signal $\Delta(t)$. If the result of counting the number of switching fixed effect change in the control of high frequency, i.e. $N \gg N^*$, and the error signal $\Delta(t)$ decreases in magnitude, but its sign relative to Δ^* does not change, the situation 1 is recognized, that is, the control system operates in a sliding mode.

If along with the change of the sign of the control action there occurs the change of the sign of the error signal $\Delta(t)$ relative to Δ^* , then the situation 2 is recognized – the mode of oscillations.

Correction of weighting coefficients should be provided on a single-layer perception learning rule

$$c_i = c_{i-1} - X_i(t) \text{sign} \Delta_{i-1} \quad (5)$$

wherein $X_i(t)$ - value of the phase point in the first switch moment, c_{i-1} - weight on the $(i-1)$ -th step of setting, Δ_i - error correction value, and the function $\text{sign}(\cdot)$ look as follows

$$\text{sign}(l) = \begin{cases} +1, & \text{if } l > 0, \\ -1, & \text{if } l < 0, \\ 0, & \text{if } l = 0. \end{cases} \quad (6)$$

Select $X_i(t)$ and Δ_i substantially affect the convergence of the learning process. In order to increase the speed of convergence to the correct solution is proposed to fix the coordinate values of $\Delta(t)$ and $\dot{x}(t)$ the first switch. Then the calculation of weighting coefficients c_i will occur not on output values, and only on the values of recorded coordinates.

Rule (5) is valid whenever the conditions which are optimal to the object mode are not met, that is, the conditions of $N \leq N^*$ and $\Delta \leq \Delta^*$ are not executed. The system execution may be terminated if the operation conditions are the $N \leq N^*$ and $\Delta \leq \Delta^*$.

In the case where one of erroneous situations is recognized, you should not wait until the system stops and final values of the state vector that are in the area of permissible error $\Delta^* \in \Omega_m$ because the information for the correction of the calculator is available, that is, the number N and X_1 , are already known. So when an

erroneous situation is detected the system can be stopped and brought to the initial state for next testing.

Thus, the algorithm of the system operation assumes that each test counts the number of sign change control signal and recording the system error and the information is used in (5) if the test results are different from those expected.

V. THE IMPLEMENTATION OF THE CONTROL SYSTEM

The approach for control dynamic plant that described in this paper can be implemented using the device, which

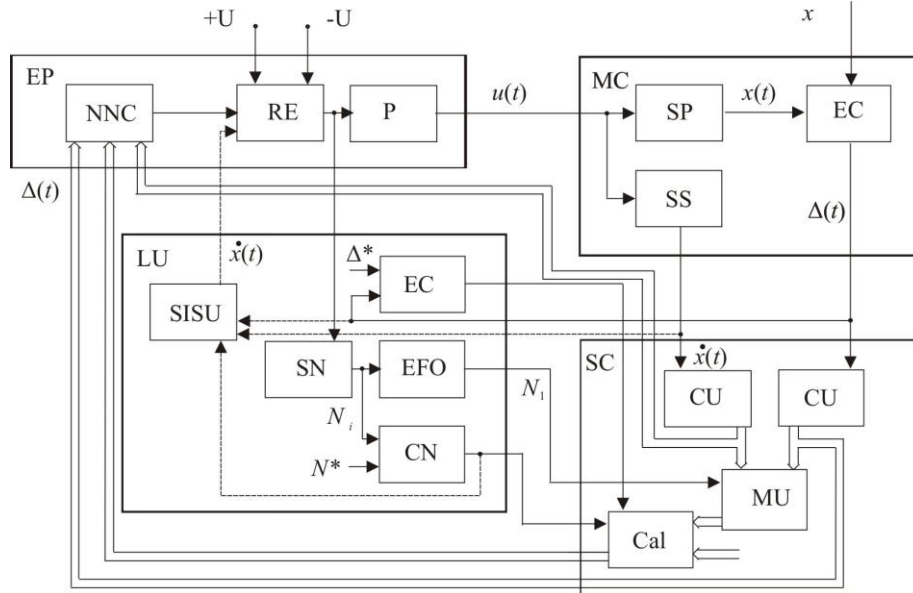

Figure 2. The structure of the control system with neural network

The operation of returning an object to its initial state $X(0)$ is implemented by stop block and the initial setting unit into which the information comes from the error calculator, the speed sensor and the switching number comparator. The output signal of this unit operates on a relay element which establishes a dynamic object on an initial state meanwhile the phase vector becomes equal to the initial value $X(t)=X(0)$. The device, which provides the implementation of the approach of weighting coefficient setting of "Adaline" system when controlling the dynamic object, operates in the following way. Before start the control system (see Fig. 2) for plant that is in the initial state $x(0)$, sets the allowable error value N^* and the exact value of the minimum number of operations N^* . Arbitrary values of weighting coefficients of the neural controller c_0 are also set. At the entrance of the system x_i is offered for testing.

The time t when the control acts on the system is considered as the initial, i.e. $t=0$. Since then the calculation of errors on position and velocity of the load with the help of the position and speed sensors and error calculator is performed. Their values are supplied to encoding units that convert the current values of position and velocity errors of object load into a digital code. This code is supplied to the signal inputs of $\Delta(t)$ i $\dot{x}(t)$ of the

control system. The inputs of the weighting coefficients c_i of the neural controller receive c_0 values from the calculator.

VI. SIMULATION OF THE BASIC PROPERTIES OF THE ALGORITHM

To model the setting system and study the basic properties of the algorithm the simulation of the object's dynamics (1) was conducted, where the matrix A and vector b look as follows

$$A = \begin{pmatrix} 0 & 1 \\ a_{21} & a_{22} \end{pmatrix}, \quad b = \begin{pmatrix} 0 \\ k \end{pmatrix} \quad (7)$$

In this case, the matrix elements a_{21} , a_{22} , k in accordance to the experimental conditions considered as unknown. Function $F(\cdot)$ for the object (1), (7) has the form

$$F(c, X(t)) = c_1 \Delta(t) + c_2 \dot{x}(t)$$

The simulation results of the proposed algorithm are shown in Fig. 3-7. Thus Fig. 3, 4 show the initial mismatch weights neural controller c_1 , c_2 in the direction of increasing, which leads to "sliding" mode dynamic plant, where Fig. 3 corresponds the sliding mode dynamic

object in the phase plane and Fig. 4 show the same mode in the time plane. In case, if detuning initial weights neural controller c_1, c_2 are in the direction of decreasing coefficients then it leads to the self-oscillations mode (see Fig. 5, 6), where Fig. 5 corresponds self-oscillation mode of the dynamic object in the phase plane and Fig. 6 show the same mode in the time plane. In Fig. 3-8 introduce the notation $\Delta(t)$ – error signal, $\dot{x}(t)$ - velocity signal, $u(t)$ - control signal.

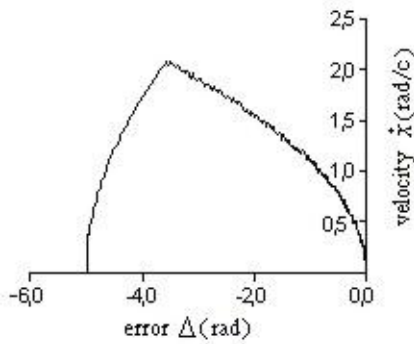

Figure 3. The sliding mode dynamic object in the phase plane

At the end of the setting process the quasi-optimal speed control process is obtained (see Fig. 7). Comparison of sliding mode (see Fig. 3) with the optimal (see Fig. 8) allows us to estimate the loss in duration of the sliding mode; in this case it is 29 %. At the same time, the quasi-optimal operating mode, which is obtained after the process of setting, loses out only 3% to the optimal mode. It was spent five iterations of the initial detuning of weighting coefficients of 100% on learning process of neural controller for investigated dynamic plant (see Fig. 9).

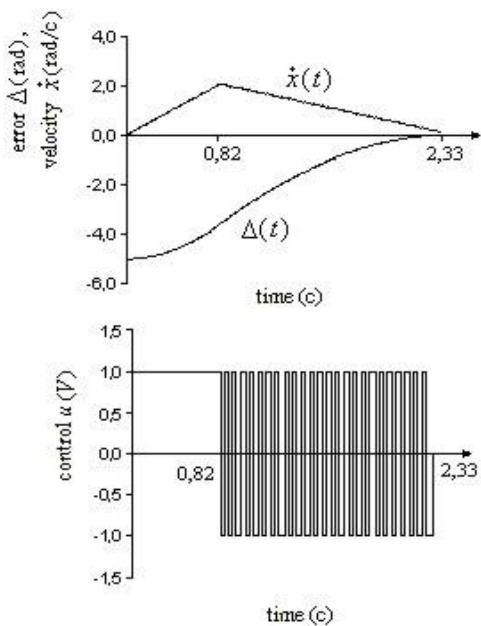

Figure 4. Signals $\Delta(t)$, $\dot{x}(t)$, and $u(t)$ of the dynamic object in the time plane with the sliding mode

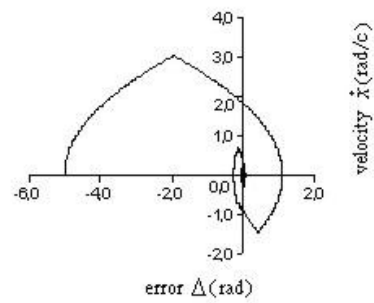

Figure 5. Self-oscillation mode of the dynamic object in the phase plane

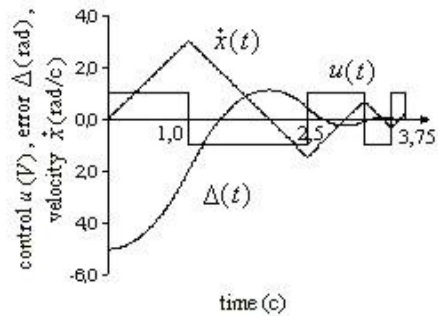

Figure 6. The $\Delta(t)$, $\dot{x}(t)$ and $u(t)$ signals of the dynamic object in the time plane at an oscillatory mode

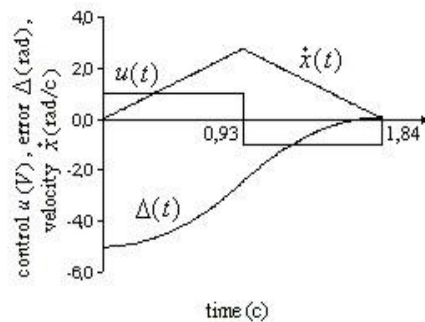

Figure 7. The $\Delta(t)$, $\dot{x}(t)$ and $u(t)$ signals of the dynamic object in quasi-optimal mode

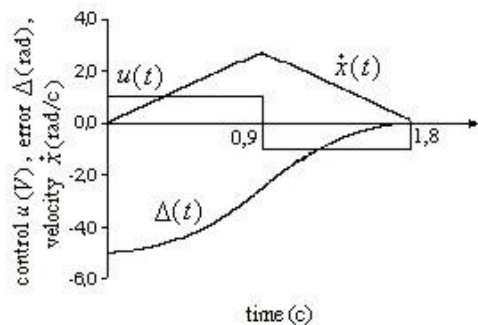

Figure 8. Signals $\Delta(t)$, $\dot{x}(t)$ and $u(t)$ of the dynamic object in the optimal mode

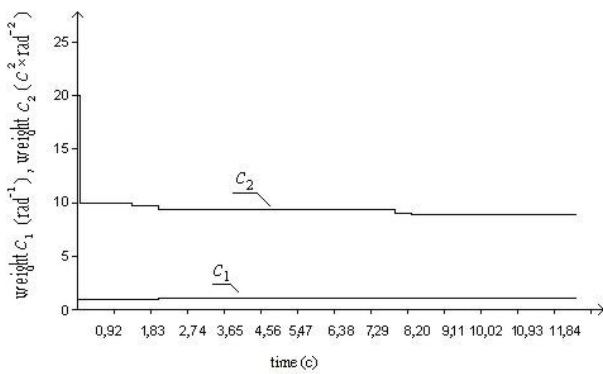

Figure 9. Correction controller coefficients c_i with neural network in training

VII. CONCLUSION

Improving the efficiency of the weighting coefficients setting of "Adaline" system for control of the dynamic object in the algorithm, which is offered in comparison with known one, implies that the accuracy of task performance with minimal time spent is achieved and duration of setting the neural network controller is reduced by monitoring the number of switching operations and use of the learning point - the point of the first change of control signal. Thus the information for learning the controller with neural network is taken by the current switching line $F(c, X(t))$, which is built at each step of learning. This setting algorithm has the best performance characteristics and additional opportunity to be trained during the system operation if the parameters of the object are changed. In case of a permanent task, you can significantly reduce the learning time of the neural controller by identifying erroneous situations and early correction of weighting coefficients of the neural network controller.

ACKNOWLEDGMENT

Authors thank both the authorities of National Aviation University and National University of Defence of Ukraine for their support during the preparation of this paper.

REFERENCES

- [1] D. P. Kucherov, "Two approaches to the problem of synthesis of high-precision servo-systems: invariance and optimality," *Journal of Automation and Information Science*, vol. 31, pp. 45-54, no. 6, 1999.
- [2] M. Ashour and A. Aboshosha, "Adaptive neural control of NPR," in *Proc. AI Azhar Engineering Fifth International Conference AEIC-97*, Cairo, Egypt, vol. 21, no. 3, December 19-22, 1997, pp. 876-880.
- [3] J. R. Noriega and H. Wang, "A direct adaptive neural network control for unknown nonlinear system and its application," *IEEE Trans. Neural Networks*, vol. 9, pp. 27-34, Jan. 1998.
- [4] K. S. Narendra, "Identification and control of dynamical systems using neural networks," *IEEE Trans. Neural networks*, vol. 1, pp. 4-27, December 2002.
- [5] M. O. Efe, "A novel error critic for variable structure control with an ADALINE," *Trans. of the Institute of Measurement and Control*, vol. 24, pp. 403-415, September 2002.
- [6] A. V. Topalov, O. Kaynak, N. G. Shakev, and S. K. Hong, "Sliding mode algorithm for online learning in fuzzy rule-based neural networks," in *Proc. 17th IFAC World Congress*, vol.17, no 1, 2008, pp. 12793-12798.
- [7] D. P. Kucherov, "A method of adjustment of weighting coefficients of "Adaline" in the control dynamic systems," *Ukraine Patent No. 81997*, February 25, 2008.
- [8] B. Widrow, G. F. Groner, M. J. Hu, F. W. Smith, D. Specht, L. R. Talbert, "Practical application for adaptive data processing systems," *WESCON Techn. Papers*, No 7, 11/4, 1963.
- [9] Y. Z. Tsyppkin, *Adaptation and Learning in Automatic Systems*, New York: Academ. Press, 1971, ch. IV.
- [10] M. Kaylon, "Design of continuous time controllers having almost minimum time response," *Transactions of the ASME*, vol. 124, pp. 252-260, June 2002.
- [11] L. Y. Pao and G. F. Franklin, "Proximate time-optimal control of third-order servomechanisms," *IEEE Transactions on Automatic Control*, vol. 38, pp. 560-580, no. 4, 1993.
- [12] A. A. Feldbaum, *Optimal Control System*, New York: Academ. Press, 1965, pp. 452.
- [13] M. Athans and P. L. Falb, *Optimal Control*, New York: McGRAW-HILL Book Company, 1966, ch. 6.



Dmitro P. Kucherov was born in Mariupol, Ukraine. He graduated from the Kiev Higher Military Engineering Radiotechnical School of Air Defence Troops, Ukraine, in 1986 and both radiotechnical engineering and Ph.D. degrees in electrical engineering in Kiev Higher Military Radiotechnical School of Air Defence Troops in 1986 and 1995, respectively. He was given the doctor's degree (Doctor of Engineering) in 2009 by Central

Research Institute of Armament of Armed Forces of Ukraine. Since 2012 he has been a professor at Computer Control Systems Department at National Aviation University, Ukraine. He is the author and co-author of two textbooks on computer power supply and the book *Method of Synthesis of Adaptive Terminal Control System*. His current teaching and research interests are in the area of adaptive control, pattern recognizing in automatic control, robot control, planning, programming and image processing. Dr. Kucherov is a member of Special Council of Central Research Institute of Armament of Ukrainian Armed Forces.



Andrei M. Kozub was born in Kiev, Ukraine. He graduated from the Kharkov Nuclear Missile College of Ukraine in 1988 and received a specialty on software of automated control systems and a qualification of engineer and mathematician. He completed postgraduate studies at the Kiev Institute of Air Force in 2001 and received Ph.D. in 2002. His thesis is devoted to technical issues of building guidance system of aircraft guided

missiles. In 2003 he was given the academic rank of a senior researcher and graduated from the National Defence Academy of Ukraine in 2004. He is a co-author of two textbooks on remote sensing of the Earth and spacecraft control of dual-use. His current teaching and research interests are in the area of space systems, devices of opto-electronic surveillance, aerospace monitoring, optimizing, complexation, efficiency, geoinformation systems, pattern recognition and remote sensing. A. Kozub is an associate professor in the area of usage of space systems and GIS software in the National University of Defence of Ukraine since 2012.



Volodimir M. Dikhtyarenko was born in Kiev, Ukraine. He graduated from Kiev Institute of Communication of the Ukrainian State Academy of Communication and received a degree of specialist in the field of automatic telecommunication in 1997. For more than 10 years he had been working as an electronics engineer at the National Communications Service Centre «UKRTELEKOM». He is an author and co-

author of 4 patents in the area of UAV. His scientific interests are in the area of Linux system and network safety. From Kiev institute of communication of the Ukrainian state academy of communication and received degree of specialist on automatic telecommunication in 1997.

More than 10 years he worked as the electronics engineer in National Communications Service Centre «UKRTELEKOM» V. Dikhtyarenko is the engineer of the 1-th category of National Aviation University since 2011.