

GEOGRAPHIC DISTRIBUTION OF GENETIC VARIATION IN TEN SPECIES

OF NORTH AMERICAN FOREST BIRDS:

ISLAND ENDEMISM AND TRANSCONTINENTAL RANGES

By

Carrie M. Topp

RECOMMENDED:

Christina L. Bennett  
[Signature]  
[Signature]  
Advisory Committee Chair

Richard D. Boone  
Chair, Department of Biology and Wildlife

APPROVED:

[Signature]  
Dean, College of Natural Science and Mathematics

[Signature]  
Dean of the Graduate School

Apr 7, 2008  
Date

GEOGRAPHIC DISTRIBUTION OF GENETIC VARIATION IN TEN SPECIES  
OF NORTH AMERICAN FOREST BIRDS:  
ISLAND ENDEMISM AND TRANSCONTINENTAL RANGES

A  
THESIS

Presented to the Faculty  
of the University of Alaska Fairbanks

in Partial Fulfillment of the Requirements

For the Degree of

MASTER OF SCIENCE

By

Carrie M. Topp, B.A.

Fairbanks, Alaska

May 2008

BIOSCI  
QL  
677.79  
F67  
T67  
2008

BIOSCIENCES LIBRARY  
UNIVERSITY OF ALASKA FAIRBANKS

**RASMUSON LIBRARY**  
UNIVERSITY OF ALASKA-FAIRBANKS

## ABSTRACT

Comparative genetic studies of geographically co-occurring species can lend insight into current and historic relationships among populations and species. This enables examination of similarities and differences among species and provides information about historic processes leading to current genetic and geographic distributions. I used this approach to study two different types of avian co-distribution: island endemism and transcontinental ranges.

The Queen Charlotte Islands (QCI), Canada, have many endemic subspecies; historically it may have been a glacial refugium. I used genetic analyses to determine subspecies uniqueness and to identify units of conservation for five species, four with endemic QCI subspecies. I found that QCI populations were genetically differentiated from mainland populations, although each species had a different isolation history, and that QCI is an important area for avian conservation and management.

East-to-west genetic splits across North America are seen in vertebrates and may be the result of Pleistocene glacial cycles. Five migratory thrushes successfully colonized northern North America. They have overlapping transcontinental ranges and similar ecological niches in woodland communities. I used genetics to determine how these thrushes established continent-wide ranges. Despite their ecological and distributional similarities these five thrush species had different patterns of colonization across North America.

## TABLE OF CONTENTS

	Page
SIGNATURE PAGE.....	i
TITLE PAGE.....	ii
ABSTRACT.....	iii
TABLE OF CONTENTS.....	iv
LIST OF FIGURES.....	viii
LIST OF TABLES.....	viii
LIST OF APPENDICES.....	viii
ACKNOWLEDGMENTS.....	ix
INTRODUCTION.....	1
LITERATURE CITED.....	3
CHAPTER 1 GENETIC PATTERNS OF DIFFERENTIATION AMONG FIVE LANDBIRD SPECIES FROM THE QUEEN CHARLOTTE ISLANDS, BRITISH COLUMBIA.....	5
1.1 ABSTRACT .....	5
1.2 INTRODUCTION .....	6
1.3 METHODS.....	10
<i>Sampling</i> .....	10
<i>Mitochondrial DNA</i> .....	11
<i>Phylogenetic analyses</i> .....	12

	Page
<i>Population structure and differentiation</i> .....	13
<i>Divergence levels</i> .....	14
1.4 RESULTS.....	15
<i>Haplotype variation and networks</i> .....	15
<i>Phylogenetic patterns</i> .....	17
<i>Genetic differentiation</i> .....	19
<i>Divergence levels</i> .....	20
1.5 DISCUSSION.....	21
<i>Differentiation</i> .....	21
<i>Patterns across species</i> .....	24
<i>Conservation and management</i> .....	26
1.6 ACKNOWLEDGEMENTS.....	28
1.7 LITERATURE CITED.....	29
FIGURES.....	40
TABLES .....	43
APPENDIX 1.....	45
CHAPTER 2 HOW MIGRATORY THRUSHES CONQUERED NORTHERN NORTH AMERICA: A COMMUNITY GENETICS APPROACH.....	46
2.1 ABSTRACT .....	46

	Page
2.2 INTRODUCTION.....	47
2.3 METHODS.....	50
<i>Sampling and mtDNA sequencing</i> .....	50
<i>Summary statistics and haplotype networks</i> .....	51
<i>Phylogenetic analysis</i> .....	52
<i>Historic population changes</i> .....	53
<i>Coalescent analyses</i> .....	54
<i>Testing divergence hypotheses</i> .....	55
2.4 RESULTS.....	57
<i>Genetic variation</i> .....	57
<i>Phylogenetic patterns</i> .....	58
<i>Historic population changes</i> .....	59
<i>Coalescent analyses</i> .....	59
<i>Testing divergence hypotheses</i> .....	61
2.5 DISCUSSION.....	62
<i>Colonization of North America</i> .....	62
<i>Patterns shared with other vertebrates</i> .....	64
<i>Divergences among thrushes</i> .....	67
<i>Conclusion</i> .....	69
2.6 ACKNOWLEDGEMENTS.....	69
2.7 LITERATURE CITED.....	70

	Page
FIGURES.....	81
TABLES.....	86
APPENDIX 2.....	88
CONCLUSIONS.....	89
<i>Island endemics</i> .....	89
<i>Transcontinental ranges</i> .....	89

## LIST OF FIGURES

	Page
Fig. 1.1 General sample locations.....	40
Fig. 1.2 Haplotype networks.....	41
Fig. 1.3 50% majority rule consensus trees for all five species.....	42
Fig. 2.1 Maps of species breeding ranges with sample location shown.....	81
Fig. 2.2 Statistical parsimony networks showing haplotype relationships.....	82
Fig. 2.3 Phylograms of deep divergences.....	83
Fig. 2.4 Divergence time in years before present.....	84
Fig. 2.5 msBayes posterior probability graphs of $\Psi$ (Psi).....	85

## LIST OF TABLES

	Page
Table 1.1 Population pairwise $F_{st}$ values (above) and $P$ -values (below).....	43
Table 1.2 Analysis of molecular variance (AMOVA).....	44
Table 2.1 Measures of genetic diversity and historical population size.....	86
Table 2.2 IM values and divergence time converted to years for $t$ and TMRCA.....	87

## LIST OF APPENDICES

	Page
APPENDIX 1.....	45
APPENDIX 2.....	88



## ACKNOWLEDGMENTS

There are a large number of people that helped and supported me through my graduate research. The individual chapters include acknowledgements for specific help with each project. However there are a few people I would like to give special thanks to. Thank you Jeffery Peters and Trina Roberts for always taking time to answer my questions when I stopped by your office. Thanks to Michael Hickerson and Naoki Takebayashi for endless help and advice on using their program msBayes before it was in a user friendly format. I would not have been able to run my data through msBayes without their help. It was a truly exciting experience working with them on such a new analysis program. Thank you to my committee members: Eduardo Wilner for always reminding me to relax and get more sleep, Christin Pruett for showing me around the molecular lab and all her helpful discussions and pertinent questions, and to my advisor, Kevin Winker, for his endless enthusiasm for research and his confidence that I could get the job done even when I had my doubts. I also want to thank my friends and family for their constant support. And lastly I want to thank my husband Roger, whose love and patience kept me going.

## INTRODUCTION

Comparative genetic studies of geographically co-occurring species can be used to evaluate current and historic relationships among populations and species and can be a useful tool for conservation and understanding evolutionary and ecological histories (Avice 2000). Genetic and geographic patterns may be especially pronounced in northern regions where past glacial activity may have caused separation over long periods of time (Hewitt 1996, Avice 2000, Griswold and Baker 2002). My thesis focuses on using the mitochondrial gene cytochrome *b* (*cyt b*) to examine two different northern bird assemblages. I chose *cyt b* because it is a well-studied gene with a relatively constant rate of evolution that has proven to be useful in many intraspecific population-level studies (Moore and DeFilippis 1997, Avice 2000).

Both of these northern bird assemblages are interesting because they currently occur in areas that were mostly covered in ice during the last glacial maxima (Pielou 1991). Thus, it is possible that the co-occurring species may share histories of divergence or colonization. One of the avian assemblages most likely had a history of isolation in a glacial refugium, causing members of the community to become genetically and phenotypically different. The other assemblage occurs across northern North America and consists of species that may have been split by glacial cycles. Both of these avian assemblages may also contain species that expanded recently into their current ranges as glaciers receded. My research examines some of these historical and evolutionary

processes, but also studies current population relationships that might be important for conservation.

In Chapter 1, I examined several species of co-occurring birds with phenotypically described endemic subspecies on the Queen Charlotte Islands, British Columbia (QCI). QCI has many endemic species across a variety of different taxa, suggesting that it may have been a glacial refugium (Warner et al. 1982, Cowan 1989, Pielou 1991, Cook et al. 2006). I compared phenotypically-described endemic avian subspecies from QCI to mainland populations using genetic analyses to evaluate subspecies uniqueness, conservation units, and management implications.

In Chapter 2, I examined five migratory North American thrush species with cross-continental ranges. Many vertebrate studies indicate that species have east-to-west genetic splits across North America that may be the result of glacial cycles during the Pleistocene or earlier (Pielou 1991, Arbogast and Kenagy 2001, Weir and Schluter 2004). These five thrushes successfully colonized North America at high latitudes. Their breeding ranges are mostly or partly overlapping, they have similar ecological niches in northern woodland communities, and as each other's closest relatives there is probably some interspecific competition. I used population genetics to determine how these five similar, but independent, lineages successfully colonized North America continent-wide to become integral members of northern forest communities.

## LITERATURE CITED

- Arbogast, B. S., and G. J. Kenagy. 2001. Comparative phylogeography as an integrative approach to historical biogeography. *Journal of Biogeography* 28:819-825.
- Avice, J. C. 2000. *Phylogeography: The History and Formation of Species*. Harvard University Press, Cambridge, Massachusetts.
- Cook, J. A., N. G. Dawson, and S. O. MacDonald. 2006. Conservation of highly fragmented systems: the north temperate Alexander Archipelago. *Biological Conservation* 133:1-15.
- Cowan, I. M. 1989. Birds and Mammals on the Queen Charlotte Islands. Pages 175-186 in *The Outer Shores* (G. G. E. Scudder and N. Gessler, Eds.). Queen Charlotte Islands Museum Press, Skidgate, Queen Charlotte, British Columbia.
- Griswold, C. K., and A. J. Baker. 2002. Time to the most recent common ancestor and divergence times of populations of common chaffinches (*Fringilla coelebs*) in Europe and North Africa: Insights into Pleistocene refugia and current levels of migration. *Evolution* 56:143-153.
- Hewitt, G. M. 1996. Some genetic consequences of ice ages, and their role in divergence and speciation. *Biological Journal of the Linnean Society* 58:247-276.

- Moore, W. W., and V. R. DeFilippis. 1997. The window of taxonomic resolution for phylogenies based on mitochondrial cytochrome *b*. Pages 84-115 in *Avian Molecular Evolution and Systematics* (D. P. Mindell, Ed.). Academic Press, San Diego, California
- Pielou, E. C. 1991. *After the Ice Age: the Return of Life to Glaciated North America*. University of Chicago Press, Illinois.
- Warner, B. G., R. W. Mathews, and J. C. Clague. 1982. Ice-free conditions on the Queen Charlotte Islands, British Columbia, at the height of the late Wisconsin glaciation. *Science* 218:675-677.
- Weir, J. T. and D. Schluter. 2004. Ice sheets promote speciation in boreal birds. *Proceedings of the Royal Society of London, Series B, Biological Sciences* 271:1881-1887.

## CHAPTER 1

GENETIC PATTERNS OF DIFFERENTIATION AMONG FIVE LANDBIRD SPECIES FROM THE QUEEN CHARLOTTE ISLANDS, BRITISH COLUMBIA<sup>1</sup>

1.1 ABSTRACT.— The Queen Charlotte Islands (QCI), British Columbia, have many putative endemic avian subspecies. We evaluated four species— Northern Saw-whet Owl (*Aegolius acadicus*), Hairy Woodpecker (*Picoides villosus*), Steller's Jay (*Cyanocitta stelleri*), and Pine Grosbeak (*Pinicola enucleator*), each with a phenotypically described endemic subspecies from QCI—for uniqueness, conservation concern, and management. The Chestnut-backed Chickadee (*Poecile rufescens*), with no endemic subspecies from QCI, was included for comparison. We hypothesized that the four endemics would have similar phylogeographic patterns of genetic divergence and coalescence between QCI and possible source populations, because they may share a glacial-refugium history. Cytochrome *b* was sequenced for all species from Alaska, Washington, and QCI. The four species with endemic phenotypes from QCI had significant genetic divergence from nearby conspecific populations, though variation in divergence times indicated varying colonization histories. Given the corroboration between morphological and genetic evidence for derived

---

<sup>1</sup> Topp, C. M., and K. Winker. (in press) Genetic patterns of differentiation among five landbird species from the Queen Charlotte Islands, British Columbia. *The Auk*.

populations from QCI, the four endemic subspecies exhibit hallmarks of being evolutionarily significant units (ESUs) and, at the least, should be considered separate management units (MUs), distinct population segments (DPSs), or designatable units (DUs). This is reflected in existing subspecific nomenclature, which our genetic results support. Chestnut-backed Chickadees had genetic differentiation in southeast Alaska as a separate MU but no significant differentiation in QCI. Our results indicate that QCI has been an important area for the generation of avian diversity below the species level and that it is an important area for the conservation and management of birds in northwestern North America.

Key words: conservation, mtDNA, endemism, Haida Gwaii, phylogeography, Queen Charlotte Islands, subspecies.

## 1.2 INTRODUCTION

A high percentage of extinctions occurs on islands, so the taxonomic validity of island endemics, their distributions, and their histories should be a priority both for an understanding of lineage history and for regional management and conservation (BirdLife International 2000, Mayr and Diamond 2001, Cook et al. 2006).

Phylogeographic structure may be particularly pronounced in northern areas affected by past glaciations that caused the separation of populations over evolutionary time

(Hewitt 1996, Avise 2000, Griswold and Baker 2002). Genetic studies of isolated populations and taxonomic subspecies can be useful for understanding the process of speciation and for determining which populations are evolutionarily significant units (ESUs) and, thus, important for the conservation of biodiversity (Moritz 1994, Avise 2000, Cook and MacDonald 2001). Comparative phylogeography is often used to seek genetic patterns across taxa with similar geographic ranges and can provide insight into the processes and areas generating biodiversity and the regional importance of such areas for conservation (Avise 1994, 2000; Bermingham and Moritz 1998; Moritz and Faith 1998; Cook et al. 2001; Calsbeek et al. 2003).

An important area of within-species biodiversity on the northwest Pacific coast of North America is the Queen Charlotte Islands (QCI, or Haida Gwaii), located ~80 km from the coast of mainland British Columbia and about 50–70 km from the two closest islands of the Alexander Archipelago in southeast Alaska. British Columbia and southeast Alaska were mostly covered with ice during the Wisconsin glaciation, but it has been suggested that there was either a refugium or multiple refugia near QCI that isolated populations and caused differentiation from mainland populations in many taxa (e.g., Warner et al. 1982, Heusser 1989, Pielou 1991, Hetherington et al. 2004, Lacourse et al. 2005, Cook et al. 2006). Endemic species and subspecies described from QCI include plants (Ogilvie 1989), insects (Kavanaugh 1989, Clarke et al. 2001), fish (Moodie and Reimchen 1976, O'Reilly et al. 1993), birds (American Ornithologists' Union [AOU] 1957, Cowan 1989, Sealy 1998), and mammals (Cowan 1989). There are



also regional patterns of species with genetically distinct clades or named endemic subspecies with ranges that include QCI and southeast Alaska or coastal Canada; examples include ermine (*Mustela erminea*; Fleming and Cook 2002) and Northern Goshawks (*Accipiter gentilis*; Sonsthagen et al. 2004). Described phenotypic endemism, coupled with the glacial history of the region, make QCI and southeast Alaska a potentially important area for the generation of biodiversity at high latitudes. Given the importance of this region for forestry and the often dramatic effects that timber harvest has on habitat availability for endemic, forest-dependent lineages, these areas are also important from a regional management and conservation perspective (Cook et al. 2006).

Here, we examine the phylogeography of five regionally codistributed, forest-dependent avian species from QCI to determine whether there is a genetic pattern of differentiation as suggested by subspecific (i.e., phenotypic) endemism and to bring genetic data to bear on regional issues of management and conservation. We asked three main questions: (1) Do avian populations of endemic sedentary subspecies from QCI show genetic differentiation from other regional populations? (2) Are patterns of phylogeographic differentiation and coalescence similar among species? And (3) do genetic data indicate that these areas are important for conservation and management? Specifically, we examined populations of Northern Saw-whet Owls (*Aegolius acadicus*), Hairy Woodpeckers (*Picoides villosus*), Steller's Jays (*Cyanocitta stelleri*), and Pine Grosbeaks (*Pinicola enucleator*). We chose these species because they are forest-dependent and have putative subspecific (i.e., phenotypic) endemism in the

region of QCI, and because the endemic populations are nonmigratory (AOU 1957, Cowan 1989, Sealy 1998). Furthermore, we corroborated the phenotypic characters on which the attribution of subspecific endemism was based by reference to the same specimens used to study the population genetics. We also included Chestnut-backed Chickadees (*Poecile rufescens*) for comparative purposes, because they have no described phenotypic endemism in the study region (AOU 1957).

We sequenced the mitochondrial gene cytochrome *b* (*cyt b*) and compared patterns of genetic differentiation within and among these five species. We hypothesized that the four species with phenotypically described endemism from QCI would have similar phylogeographic structure, patterns of genetic divergence, and coalescent properties. Conversely, the Chestnut-backed Chickadee, with no described endemism in the region, is a natural control and would probably not share patterns of differentiation with endemics or have much phylogeographic structure.

Mitochondrial sequence data have little bearing on the validity of phenotypically described subspecies because the predominantly silent substitutions of mitochondrial DNA (mtDNA) variation at the intraspecific level are expected to be decoupled from differentiation resulting from selection on phenotype (e.g., Bulgin et al. 2003, Mumme et al. 2006). However, subspecific variation does suggest underlying genetic differentiation, and mitochondrial genetic data can help us understand some of the deeper evolutionary history of intraspecific variation. It can also be valuable for genetic diagnoses of populations and regions that warrant special management or conservation

attention (Moritz 1994; Avise 2000; Cook et al. 2001, 2006; Phillimore and Owens 2006).

### 1.3 METHODS

*Sampling.*—We included four landbird species with phenotypic endemism from QCI in the study: Northern Saw-whet Owl and its QCI endemic, *A. a. brooksi*; Hairy Woodpecker and its QCI endemic, *P. v. picoideus*; Steller's Jay and its QCI endemic, *C. s. carlottae*; and Pine Grosbeak and its QCI endemic, *P. e. carlottae* (AOU 1957, Cowan 1989, Sealy 1998). The Chestnut-backed Chickadee was used for comparison. All these species are nonmigratory except the nominate Northern Saw-whet Owl, and *A. a. brooksi* is nonmigratory (Sealy 1998). Cytochrome *b* was used because it is a well-studied gene with a fairly constant rate of evolution and has proved useful in many intraspecific population-level studies (Moore and DeFilippis 1997, Avise 2000). Voucher specimens are listed in the Appendix 1.

For each species comparison, we used three main sample regions: Alaska, Washington–Oregon, and QCI (Fig. 1.1). Although these are political units, they make biological sense in the context of the northwest Pacific coastal distributions of these species. The Washington–Oregon region covers coastal mainland populations south of QCI. Alaska does not, at first, seem to be a single region, given its large size; however, most Alaska specimens were from the continuous southern coastal area between mountain ranges and the ocean that shares a glacial history and matches the Alaska distributions for all these species except Pine Grosbeaks and Hairy Woodpeckers, which

are also found in the interior (Pielou 1991, Cannings 1993, Greene et al. 1998, Adkisson 1999, Dahlsten et al. 2002, Jackson et al. 2002). We included a single Hairy Woodpecker from Minnesota and several from interior Alaska to increase sample size in this species; the Minnesota sample was not used in statistical population comparisons.

*Mitochondrial DNA.*—Total genomic DNA was extracted from muscle tissue following Glenn (1997) or DNeasy DNA purification kit protocols (Qiagen, Valencia, California). DNA was amplified for most or all of cytochrome *b* using the following forward and reverse primers: L0-25 (5'-ATGGCCCCAAACATCCGAAAGTCTC-3') and H1117 (5'-GGGTGCTTGCTAT TGGGAGTAGGACGAGG-3') for Northern Saw-whet Owls (971 base pairs [bp]); L14841 (Helm-Bychowski and Cracraft 1993) and H16065 (Kocher et al. 1989) for Hairy Woodpeckers, Steller's Jays, and Chestnut-backed Chickadees (1,045 bp); and L14851 (Kornegay et al. 1993) and H16064 (Harshman 1996) for Pine Grosbeaks (1,143 bp). Primer numbers correspond to *cyt-b* nucleotide positions in the chicken, *Gallus gallus domesticus* (Desjardins and Morais 1990). All amplifications were performed using *Taq* DNA Polymerase with buffer B (Promega Corporation, Madison, Wisconsin) and standard polymerase chain reaction (PCR) protocols (Hillis et al. 1996). Samples were purified with PEG precipitation and cycle-sequenced using Big Dye Terminator 3.1 (Applied Biosystems, Foster City, California). The amplified cycle-sequenced product was cleaned using sephadex

purification columns and sequenced in both directions using standard protocols on an ABI 373 or 3100 automated sequencer (Applied Biosystems).

Mitochondrial sequence data were edited, aligned, and checked for stop codons indicative of nonfunctional nuclear copies using SEQUENCHER, version 4.1 (Gene Codes, Ann Arbor, Michigan). We then blasted sequence data on NCBI GenBank to ensure that the closest matches were avian *cyt b*. Using DNASP, version 3.99.5 (Rozas and Rozas 1999), sequences were examined for haplotype variation, variable base pairs, fixed differences in populations, and number of segregating sites (S). Unrooted median-joining networks were constructed for each species in NETWORK, version 4.2.0.2 (Bandelt et al. 1999; [www.fluxus-engineering.com](http://www.fluxus-engineering.com)). For comparison, statistical-parsimony networks were made with TCS 1.21 (Clement et al. 2000). We also imported sequences into PAUP\*, version 4.0b10 (Swofford 2001), and made unrooted parsimony networks for each species and mapped mutations and ambiguity circles onto them by hand. These three methods were used to find the most parsimonious haplotype networks.

*Phylogenetic analyses.*—The best-fit maximum-likelihood (ML) model of molecular evolution for each species was selected using ML scores from PAUP\* and Akaike's information criterion (AIC) for model selection as implemented in MODELTEST, version 3.06 (Posada and Crandall 1998, Posada and Buckley 2004). Maximum-likelihood analyses with heuristic search algorithm, 100 random additions, and TBR branch-swapping were used to reconstruct phylogenetic relationships among

individuals in PAUP\*, using the selected best-fit models of evolution. Bootstrap support was evaluated by resampling each data matrix 1,000 times (Felsenstein 1985). Trees were rooted with outgroup taxa thought to be closely related. The outgroup sequences were acquired from GenBank or from University of Alaska Museum specimens (GenBank accession numbers available on request).

Bayesian analyses using the same MODELTEST parameters for each species were conducted using MRBAYES, version 3.1 (Huelsenbeck and Ronquist 2001, Ronquist and Huelsenbeck 2003, Altekar et al. 2004). Four independent runs starting from random trees were used for each species to ensure that the Markov chain converged on the optimal likelihood value. Trees were sampled every 10,000 generations, and the analyses were run for 8 million generations. All trees sampled before the Markov chain plateaued were discarded (the “burn-in”), and remaining trees were used to approximate posterior probabilities for each phylogeny (Huelsenbeck and Ronquist 2001). Trees were then imported into PAUP\*, where majority-rule consensus trees were made with the posterior probabilities of each clade recorded as the percentage of that clade occurring among all the sampled trees (Huelsenbeck and Ronquist 2001).

*Population structure and differentiation.*—Population differentiation was investigated with population pairwise  $F_{st}$  estimates from haplotype frequencies using ARLEQUIN, version 2.0 (Schneider et al. 2000). Significance of  $P$  values was determined after sequential Bonferroni corrections. To examine population structure, we used Nei’s average population pairwise comparisons to test for differentiation

between sample regions and to compare QCI and all other samples, again in ARLEQUIN. Homogeneity of mtDNA haplotype distributions within and among populations was assessed using analysis of molecular variance (AMOVA), implemented in ARLEQUIN.

*Divergence levels.*—An estimate of QCI population-divergence time was calculated for each species using 1.6% (Fleischer et al. 1998) to 2% (Shields and Wilson 1987) sequence divergence per million years. This calculation used net number of nucleotide substitutions per site between QCI and all other populations as calculated in DNASP.

To test the hypothesis of simultaneous divergence or colonization times among species from QCI, we used MSBAYES (Hickerson et al. 2006). This program uses an approximate Bayesian computational (ABC) framework that tests for simultaneous divergence across multiple codistributed taxon pairs using a hierarchical model that incorporates intrinsic variation such as ancestral coalescence and among-taxon demographic histories (Hickerson et al. 2006). This method allows for the simultaneous estimation of three hyper-parameters that characterize the mean ( $E[\tau]$ ), variability ( $\Omega$ ), and number of separate divergence events ( $\Psi$ ) across multiple population pairs (Hickerson et al. 2006). The ABC method obtains these estimates by simulating data and their summary statistics from the joint prior distribution under a model and then sampling from the resulting joint posterior distribution using probabilities based on the similarity between the summary statistic vector for observed versus simulated data (Hickerson et al. 2006).

We ran two million simulations in MSBAYES using the following starting parameters for the upper and lower bounds of prior distributions:  $\theta$  lower = 0.5 (default),  $\theta$  upper = 10.0 (based on the highest  $\pi_W$  from observed summary statistics as recommended by Hickerson et al. [2006]),  $\tau$  upper = 10.0 (based on relatively recent divergence in the past 1 million years), migration rate upper = 10.0 (some migration is possible), recombination rate upper = 0.0 (mtDNA has no recombination), and ancestral population size upper = 0.5 (default). We report joint posterior estimates based on the summary statistic vector **D** that includes the twenty summary statistics ( $\pi_{net}$ ,  $\pi$ ,  $\theta_W$ ,  $\text{Var}[\pi-\theta_W]$  per taxon pair) and a tolerance of 0.001, which yielded estimates based on 2,000 draws from the joint posterior, given that there were two million simulated draws from the joint prior.

#### 1.4 RESULTS

*Haplotype variation and networks.*—The five species exhibited varying degrees of intraspecific genetic diversity, with a range of 3–22 haplotypes within each species (Fig. 1.2). Segregating sites (S) for each species varied accordingly: 2 in Northern Saw-whet Owls, 20 in Hairy Woodpeckers, 20 in Steller’s Jays, 37 in Pine Grosbeaks, and 8 in Chestnut-backed Chickadees. Most nucleotide mutations for all species were third-position synonymous changes. The four regionally polytypic species had one to seven haplotypes that were found only from QCI (not shared with other locations), though the haplotype networks showed phylogeographic patterns that were different for each species (Fig. 1.2).



Haplotype networks made with TCS and NETWORK were almost identical, except for one ambiguity loop in the Steller's Jay network that was not seen with TCS (not shown). However, neither program produced the shortest possible networks across all five species when compared with nucleotide mutations. Northern Saw-whet Owl and Chestnut-backed Chickadee relationships were identical under all methods. Steller's Jays were also very similar. Pine Grosbeaks and Hairy Woodpeckers had larger haplotype divergences that may have interfered with the programs' abilities to find the shortest networks, adding two to three more steps than necessary (not shown). To visualize the most parsimonious networks with relationship ambiguities for all species, we mapped mutations and ambiguity loops onto networks by hand (Fig. 1.2).

The endemic population of *A. a. brooksi* from QCI had a single haplotype that differed by one fixed base pair from all other haplotypes (Fig. 1.2a). Similarly, Hairy Woodpeckers of the endemic population *P. v. picoides* from QCI had one fixed base pair that differed from all the other specimens (Fig. 1.2b). The woodpecker network had two distinct groups that were separated by at least six mutations (Fig. 1.2b). Each of these groups included individuals from Washington. The QCI Steller's Jay population (*C. s. carlottae*) did not share haplotypes with any other population (Fig. 1.2c). However, five birds from Alaska shared one base-pair difference with QCI that differentiated this group from Washington specimens and the other six Alaska birds (Figs. 1.2c and 1.3c).

Six of seven Pine Grosbeak haplotypes from QCI (all birds phenotypically identified as *P. e. carlottae*) shared three fixed mutations and four more almost-exclusive mutations that were each shared with one of three Alaska individuals (not apparent in the network; some mutations are mapped multiple times because haplotypes are very divergent; Fig. 1.2). The seventh haplotype from QCI occurred in one bird (also identified as *P. e. carlottae*) that was in a separate group that included one Washington and three Alaska birds; this group was separate from the QCI and Washington–Alaska groups by three exclusive base-pair changes (Fig. 1.2d). All QCI Pine Grosbeak haplotypes had another mutation that was shared with four Alaska and one Washington individual (Fig. 1.2d).

In contrast to the other species, 6 of 10 Chestnut-backed Chickadees from QCI shared a common haplotype with 5 individuals from Alaska (Fig. 1.2e). Chickadees also had 1 fixed difference in a group of 11 southeast-Alaska individuals from Ketchikan and Hyder (Figs. 1.1e and 1.2e).

*Phylogenetic patterns.*—The best-fit ML models inferred with MODELTEST were used in reconstructing phylogenetic trees for each species: F81 for Northern Saw-whet Owls, K81uf for Hairy Woodpeckers, TrN+I for Steller’s Jays and Pine Grosbeaks, and HKY for Chestnut-backed Chickadees (Posada and Crandall 1998). Maximum-likelihood trees reconstructed using *cyt-b* sequence data with 1,000 bootstrap replicates showed the same topology as the Bayesian majority-rule consensus trees (Fig. 1.3). For all species, a 100,000-generation burn-in was sufficient to sample the Markov chain

after it reached a plateau. Therefore, 791 trees were used from across 8 million generations to build majority-rule consensus trees for each species.

The Northern Saw-whet Owl phylogeny had one clade that exclusively included individuals of *A. a. brooksi* from QCI and was supported by a posterior probability of 0.87; the other owls were not significantly differentiated (Fig. 1.3a).

Hairy Woodpeckers had geographically distinct clades with posterior probabilities of 0.98 and higher (Fig. 1.3b). One of these clades included the QCI birds, and another was dominated by interior-Alaska birds (Fig. 1.3b). All the southeast-Alaska individuals, two Washington individuals, and the one Minnesota individual were related to the interior-Alaska-dominated clade (Fig. 1.3b). Three Washington individuals were more closely associated with the QCI clade (Fig. 1.3b).

Steller's Jays also showed geographic structure. Five Alaska individuals (three Prince of Wales Island, one Auke Bay, and one south-central) occurred in a strongly supported clade with all the QCI birds (Fig. 1.3c). Another well-supported clade consisted of two Auke Bay specimens, but the third Auke Bay specimen was in the QCI clade (Fig. 1.3c). Southeast-Alaska specimens from Prince of Wales Island and Ketchikan were different; the Prince of Wales Island birds clustered with QCI, and all the Ketchikan birds grouped with Washington (Fig. 1.3c).

Pine Grosbeaks had the most structure and complexity. The QCI individuals were paraphyletic, but most were in a single clade with a posterior probability of 0.96 (Fig. 1.3d). One QCI individual occurred in another well-supported clade that included three

southeast-Alaska specimens and one from Washington (Fig. 1.3d). One of the latter was phenotypically identified by plumage and measurements as *P. e. carlottae*, the putative endemic QCI subspecies (UAM 6758), as was the specimen in this clade from QCI (UAM 9265). This result was unexpected but was verified by re-cutting, re-extracting, and re-sequencing these samples. Bayesian and ML trees also had a south-central-Alaska specimen (UAM 13086) as sister to the QCI population of *P. e. carlottae* (Fig. 1.3d). This specimen has been identified by phenotype as an Alaska subspecies, *P. e. leucura*.

Chestnut-backed Chickadees showed less geographic structure than the other species. One of the two most strongly supported clades, each with a posterior probability of 0.98, included four Washington individuals and the single specimen from Oregon (another Washington bird was not in this clade; Fig. 1.3e). The other clade included two QCI individuals. The 11 southeast-Alaska individuals from Ketchikan and Hyder formed a clade with a posterior probability of 0.85 (Figs. 1.1e and 1.3e).

*Genetic differentiation.*—Population pairwise  $F_{st}$ -values were used to estimate differentiation between populations (Table 1.1). Northern Saw-whet Owls showed significant differentiation between QCI and all other populations, with  $F_{st}$ -values of 0.9–1.0. The Washington and Alaska owl populations were not significantly differentiated (Table 1.1). Hairy Woodpeckers exhibited nonsignificant differentiation between QCI and other populations, despite substantial phylogeographic structure, likely because our small sample size reduced the power to detect differentiation (Table

1.1 and Fig. 1.3b). Steller's Jays had significant  $F_{st}$ -values between all population pairs except Washington and Alaska (Table 1.1). Pine Grosbeaks showed significant differentiation between QCI and Alaska and between QCI and all other specimens combined (Table 1.1). The lack of significant differentiation between QCI and Washington is probably attributable to our small sample size from Washington, given that there was pronounced phylogenetic differentiation (Table 1.1 and Fig. 1.3d). Chestnut-backed Chickadees had similar  $F_{st}$ -values across all population pairs and significant  $P$  values after Bonferroni corrections, except for the Alaska-versus-QCI comparison (Table 1.1). Nei's population pairwise differences using haplotype frequencies (not shown) had similar results.

Analysis of molecular variance within and between populations was conducted to determine how total genetic variation was partitioned among populations within each of the five species (Table 1.2). Northern Saw-whet Owl was the only species that showed a higher percentage of variation among populations than within populations; in the other species, >68% of total genetic variation occurred within populations (Table 1.2).

*Divergence levels.*—Rough estimates of divergence time for each species between QCI and other populations were as follows: 51,500–64,375 years before present (ybp) for Northern Saw-whet Owls, 281,500–351,875 ybp for Hairy Woodpeckers, 46,500–58,125 ybp for Steller's Jays, 243,500–304,375 ybp for Pine Grosbeaks, and 14,500–18,125 ybp for Chestnut-backed Chickadees.

Estimates calculated in MSBAYES for the ratio of variance to mean divergence times ( $\Omega = 0.521$ , 95% quantiles: 0.045–5.711) and the number of divergence times across taxon pairs ( $\Psi = 4.68$ , 95% quantiles: 1.126–5.000) did not support a history of simultaneous divergence or colonization of QCI populations of the five species in the study. Whereas  $\Omega = 0$  is expected for a set of species pairs with one divergence event, the probable number of divergence events across all species in the present study was very close to five, or one for each species.

### 1.5 DISCUSSION

The four species with putative phenotypic endemism in QCI populations, Northern Saw-whet Owl, Hairy Woodpecker, Steller's Jay, and Pine Grosbeak, all showed genetic differentiation when QCI was compared with other nearby populations using *cyt-b* sequence data (Figs. 1.2 and 1.3). These genetic data support the endemic subspecies originally described from phenotypic differences. However, these species do not share the same phylogeographic pattern in the QCI region, which suggests different divergence times and colonization histories and, possibly, different levels of conservation concern for taxa with QCI endemism (Figs. 1.2 and 1.3).

*Differentiation.*—Results indicate that the putative endemic QCI subspecies *A. a. brooksi* has significant genetic differentiation in addition to phenotypic and behavioral differentiation restricted to QCI (Sealy 1998, Committee on the Status of Endangered Wildlife in Canada [COSEWIC] 2006). Phylogenetic analyses indicate substantial separation of QCI Hairy Woodpeckers, but  $F_{st}$ -values were not significant (Figs. 1.2 and

1.3, Table 1.1). This observed variation in support of QCI differentiation between analytical methods was probably a result of low sample size, though coastal versus interior differentiation (Figs. 1.1b, 1.2b, and 1.3b) may also have contributed. This species proved difficult to obtain in numbers from any of our study areas and warrants more work with increased sampling (Fig. 1.1b). Despite our small sample size from QCI, it seems that this population is genetically different from other populations.

The relationships found in Steller's Jays may indicate (1) some level of relatively recent gene flow from QCI into southeast Alaska after a history of separation or (2) a recently separated population in QCI that shares ancestral haplotypes with Prince of Wales Island. Either recent movement or incomplete lineage-sorting might explain why strong phylogeographic differentiation was not observed in the Bayesian or ML trees outside of the clade containing all QCI individuals (Fig. 1.3c). At the present time, QCI Steller's Jays appear to represent a genetically and phenotypically distinct population. Supporting this conclusion, a recent study with larger sample sizes and more loci found high levels of differentiation in QCI populations of this species (Burg et al. 2005).

The unexpected clade found in Pine Grosbeaks (Fig. 1.3d), with two phenotypically identified *P. e. carlottae* having divergent ("non-QCI") haplotypes, suggests that gene flow, incomplete lineage sorting, or both are occurring between QCI and other populations. The fact that one of these birds was from mainland Alaska suggests that gene flow is occurring from QCI to the mainland (AOU 1957). The relationship between the south-central-Alaska individual and the main QCI clade (Fig. 1.3d) also

suggests gene flow or incomplete lineage-sorting between Alaska and QCI populations. Uneven sampling may have affected results because we were only able to obtain three samples from Washington. The complex genetic relationships of Pine Grosbeaks in our study region warrant further research with larger samples sizes, more extensive sampling, and additional loci to disentangle gene flow from lineage sorting as factors affecting the genetic isolation of the QCI population. However, our results indicate that Pine Grosbeaks from QCI are significantly divergent in phenotype and genotype from other conspecific populations.

The observed differentiation among populations of Chestnut-backed Chickadees may be attributable to isolation by distance; this species does not migrate and has very limited movements. Our results support significant genetic differentiation in lower southeast Alaska and between Washington and both QCI and Alaska populations. The most central, and possibly ancestral, haplotype included individuals from south-central Alaska, QCI, and northern southeast Alaska (Fig. 1.2e), which suggests possible colonization into southeast Alaska from a larger source population. This is tentative, because we have few samples from Washington and Oregon and none from mainland British Columbia.

A recent microsatellite study of Chestnut-backed Chickadees in the same region found high levels of allelic variation in all populations (Burg et al. 2006), which is consistent with our AMOVA analysis and significant  $F_{st}$  results found using *cyt b*. Burg et al. (2006) also found distinct genetic differentiation in northern southeast Alaska and



QCI, which is not congruent with our mitochondrial results showing differentiation in southern southeast Alaska. Differences in mutation rates and lineage-sorting between the mitochondrial and nuclear marker systems used in Burg et al. (2006) and the present study probably contributed to these observed differences.

*Patterns across species.*—Genetic patterns of these codistributed species in the QCI region seem to differ in several details, while also—among those with phenotypically-based QCI endemics—sharing QCI-related genetic differentiation. The haplotype networks and phylogenetic trees showed that genetic haplotype diversity varies greatly among these species (Figs. 1.2 and 1.3). The Northern Saw-whet Owl had low genetic diversity, three haplotypes separated by single base-pair changes, but clear differentiation of the QCI population (Figs. 1.2a and 1.3a). In comparison, Hairy Woodpeckers and Pine Grosbeaks had many more haplotypes (12 and 22, respectively) within and among populations than Northern Saw-whet Owls, and they had more complex genetic structure and relationships, with more base-pair differences between haplotypes (Figs. 1.2 and 1.3). Steller's Jays also had high genetic diversity (17 haplotypes), but the genetic relationships showed less structure and distance than, for example, Hairy Woodpeckers, and the phylogenetic tree did not have complete genetic separation of the QCI subspecies *C. s. carlottae*, even though haplotypes were not shared between QCI and other populations (Figs. 1.2c and 1.3c). Chestnut-backed Chickadees had more genetic variation than Saw-whet Owls but had very few mutations between haplotypes when compared with Hairy Woodpeckers and Pine Grosbeaks.

In agreement with variation in levels of genetic divergence, rough estimates of divergence times based on an assumed avian *cyt-b* clock (Shields and Wilson 1987, Fleischer et al. 1998) suggested multiple different divergence events among these species. On the basis of these date ranges, all the QCI populations of these species appear to have diverged before the end of the last glacial maximum at ~13,000 ybp, except perhaps the Chestnut-backed Chickadee (Sutherland Brown 1968, Pielou 1991, Hetherington et al. 2004). These findings provide some support for divergence in a glacial refugium in or near QCI for the endemic populations, as opposed to divergence following postglacial colonization; however, these divergence estimates are far from exact (Lovette 2004).

The test of simultaneous divergence of QCI populations using MSBAYES agreed with our other findings that among these species, the QCI populations most likely did not diverge simultaneously but at as many as five different times. Observed differences in divergence patterns and haplotype variation among these species are probably attributable to different colonization histories, gene flow, and lineage sorting, but the overlying outcome of the present study is that the species with phenotypically described subspecific endemism from QCI also have significant genetic differentiation of those populations (Maddison and Knowles 2006).

These results are given with the caveat that sampling effects may play some role in the among-species variance in the genetic differentiation observed from QCI. We were unable to sample mainland British Columbia, and these species have wider ranges

across North America that we did not sample. Resolution of refugial locations, contemporary levels of gene flow, vicariant histories, and directions of colonization will require increased sampling: numerically, geographically, and with more genetic markers.

*Conservation and management.*—For conservation and management efforts in southeast Alaska and QCI, the present study provides genetic evidence for population-level divergence among four avian species with endemic subspecies based on phenotypic differentiation (“QCI endemics”) and also for one species without such recognized phenotypic endemism (Chestnut-backed Chickadees in southeast Alaska). Patterns of genetic endemism in this region are correlated with phenotypic (subspecific) endemism and are concentrated in QCI. The QCI endemics seem to be on independent evolutionary trajectories compared with mainland populations and are consistent with the high levels of endemism seen among other taxa from QCI (AOU 1957, Moodie and Reimchen 1976, Cowan 1989, Kavanaugh 1989, Ogilvie 1989, O’Reilly et al. 1993, Sealy 1998, Clarke et al. 2001). Isolation in QCI has generated avian diversity below the species level that has been recognized phenotypically and that has genetic corroboration; this diversity should be managed and conserved.

Since scientists first determined the need for defining intraspecific units for effective conservation management, the concepts and unit criteria have been highly debated, and there is still no consensus (Moritz 2002, Green 2005). Four units are often used to define populations for conservation management and evolutionary importance.

(1) “Evolutionarily significant unit” (ESU) has been given several proposed definitions, but all the definitions agree that an ESU includes populations that are significantly distinct from other populations on the basis of correlation between more than one type of data, usually including genetic data or distinct adaptive variation (Ryder 1986, Waples 1991, Moritz 1994). (2) “Management unit” (MU) is a population with significant divergence of allele frequencies at nuclear or mitochondrial loci, regardless of the phylogenetic distinctiveness of the alleles (Moritz 1994). (3) “Distinct population segment” (DPS) is a population that is morphologically or genetically distinct (U.S. Department of the Interior and U.S. Department of Commerce 1996). And (4) “designatable units” (DUs) below the species level may be defined with any of the following criteria: named subspecies or variety, genetically distinct unit, major range disjunction with no gene flow, or biogeographically distinct units that inhabit different ecogeographic regions (COSEWIC 2005, Green 2005). Evolutionarily significant units focus on historical population structure, mtDNA phylogenies, and long-term conservation (Moritz 2002). Management units are concerned with current population structure, allele frequencies, and short-term management (Moritz 1994). The DPS is a politically engendered biological unit used for making conservation or management policy in the United States of America and may or may not be the same as the other categories. Similarly, DUs are politically engendered biological units used by COSEWIC for status assessment (COSEWIC 2005, Green 2005). We used these

general descriptions to describe distinct intraspecific units for the five species in the present study.

Given the corroboration of morphological and genetic evidence for derived populations from QCI, the four endemic subspecies of Northern Saw-whet Owls, Hairy Woodpeckers, Pine Grosbeaks, and Steller's Jays seem to exhibit hallmarks of being ESUs, are clearly all DPSs and DUs, and should be considered separate MUs (Ryder 1986, Moritz 1994, U.S. Department of the Interior and U.S. Department of Commerce 1996, COSEWIC 2005, Green 2005). This is reflected in existing subspecific nomenclature, with which our genetic results are concordant. On the basis of genetic data, Chestnut-backed Chickadees in lower southeast Alaska also represent a DPS and a separate MU. These results indicate that QCI has been an important area for the generation of avian diversity below the species level and that it is an important area for bird conservation and management in northwestern North America.

#### 1.6 ACKNOWLEDGMENTS

This project was supported by the University of Alaska Museum (UAM); the National Science Foundation, through an Experimental Program to Stimulate Competitive Research (EPSCoR) genomics fellowship awarded to C.M.T.; the W. Alton Jones Foundation; the Collins Alaska Trust; and Ralph Seekins. Genetic samples were supplied by UAM, the University of Washington Burke Museum, S. G. Sealy, and R. M. Zink. Thanks to S. G. Sealy, G. M. Spellman, C. L. Pruett, T. M. Boucher, D. D.

Gibson, J. M. Maley, T. M. Braile, A. B. Johnson, R. W. Dickerman, and S. Heintz for technical assistance and field sampling and to S. G. Sealy for comments on an early draft. Thanks also to two anonymous reviewers and R. T. Brumfield for helpful suggestions on the manuscript and to M. J. Hickerson and Naoki Takebayashi for assistance and guidance with MSBAYES.

#### 1.7 LITERATURE CITED

- Adkisson, C. S. 1999. Pine Grosbeak (*Pinicola enucleator*). In *The Birds of North America*, no. 456 (A. Poole and F. Gill, Eds.). Birds of North America, Philadelphia.
- Altekar, G., S. Dwarkadas, J. P. Huelsenbeck, and F. Ronquist. 2004. Parallel metropolis coupled Markov chain Monte Carlo for Bayesian phylogenetic inference. *Bioinformatics* 20:407–415.
- American Ornithologists' Union. 1957. *Check-list of North American Birds*, 5th ed. American Ornithologists' Union, Washington, D.C.
- Avice, J. C. 1994. *Molecular Markers, Natural History, and Evolution*. Chapman and Hall, New York.
- Avice, J. C. 2000. *Phylogeography: The History and Formation of Species*. Harvard University Press, Cambridge, Massachusetts.
- Bandelt, H.-J., P. Forster, and A. Röhl. 1999. Median-joining networks for inferring intraspecific phylogenies. *Molecular Biology and Evolution* 16:37–48.

- Bermingham, E., and C. Moritz. 1998. Comparative phylogeography: Concepts and applications. *Molecular Ecology* 7:367–369.
- BirdLife International. 2000. *Threatened Birds of the World*. Lynx Edicions, Barcelona, Spain, and BirdLife International, Cambridge, United Kingdom.
- Bulgin, N. L., H. L. Gibbs, P. Vickery, and A. J. Baker. 2003. Ancestral polymorphisms in genetic markers obscure detection of evolutionarily distinct populations in the endangered Florida Grasshopper Sparrow (*Ammodramus savannarum floridanus*). *Molecular Ecology* 12:831–844.
- Burg, T. M., A. J. Gaston, K. Winker, and V. L. Friesen. 2005. Rapid divergence and postglacial colonization in western North American Steller's Jays (*Cyanocitta stelleri*). *Molecular Ecology* 14:3745–3755.
- Burg, T. M., A. J. Gaston, K. Winker, and V. L. Friesen. 2006. Effects of Pleistocene glaciations on population structure of North American Chestnut-backed Chickadees. *Molecular Ecology* 15:2409–2419.
- Calsbeek, R., J. N. Thompson, and J. E. Richardson. 2003. Patterns of molecular evolution and diversification in a biodiversity hotspot: The California Floristic Province. *Molecular Ecology* 12:1021–1029.
- Cannings, R. J. 1993. Northern Saw-whet Owl (*Aegolius acadicus*). In *The Birds of North America*, no. 42 (A. Poole and F. Gill, Eds.). Academy of Natural Sciences, Philadelphia, and American Ornithologists' Union, Washington, D.C.

- Clarke, T. E., D. B. Levin, D. H. Kavanaugh, and T. E. Reimchen. 2001. Rapid evolution in the *Nebria gregaria* group (Coleoptera: Carabidae) and the paleogeography of the Queen Charlotte Islands. *Evolution* 55:1408–1418.
- Clement, M., D. Posada, and K. A. Crandall. 2000. TCS: A computer program to estimate gene genealogies. *Molecular Ecology* 9:1657–1659.
- Committee on the Status of Endangered Wildlife in Canada. 2005. Guidelines for recognizing designatable units below the species level (Appendix F5 in the COSEWIC O&P Manual). Committee on the Status of Endangered Wildlife in Canada, Ottawa, Ontario. [Online.] Available at [www.dfo-mpo.gc.ca/csas/Csas/Schedule-Horraire/Details/2005/11\\_Nov/COSEWIC\\_DU\\_guidelines\\_EN.pdf](http://www.dfo-mpo.gc.ca/csas/Csas/Schedule-Horraire/Details/2005/11_Nov/COSEWIC_DU_guidelines_EN.pdf).
- Committee on the Status of Endangered Wildlife in Canada. 2006. COSEWIC assessment and status report on the Northern Saw-whet Owl *brooksi* subspecies *Aegolius acadicus brooksi* in Canada. Committee on the Status of Endangered Wildlife in Canada, Ottawa, Ontario.
- Cook, J. A., A. L. Bidlack, C. J. Conroy, J. R. Demboski, M. A. Fleming, A. M. Runck, K. D. Stone, and S. O. MacDonald. 2001. A phylogeographic perspective on endemism in the Alexander Archipelago of southeast Alaska. *Biological Conservation* 97:215–227.



- Cook, J. A., N. G. Dawson, and S. O. MacDonald. 2006. Conservation of highly fragmented systems: The north temperate Alexander Archipelago. *Biological Conservation* 133:1–15.
- Cook, J. A., and S. O. MacDonald. 2001. Should endemism be a focus of conservation efforts along the North Pacific Coast of North America? *Biological Conservation* 97:207–213.
- Cowan, I. M. 1989. Birds and Mammals on the Queen Charlotte Islands. Pages 175–186 *in* The Outer Shores (G. G. E. Scudder and N. Gessler, Eds.). Queen Charlotte Islands Museum Press, Skidgate, Queen Charlotte, British Columbia.
- Dahlsten, D. L., L. A. Brennan, D. A. McCallum, and S. L. L. Gaunt. 2002. Chestnut-backed Chickadee (*Poecile rufescens*). *In* The Birds of North America, no. 689 (A. Poole and F. Gill, Eds.). Birds of North America, Philadelphia.
- Desjardins, P., and R. Morais. 1990. Sequence and gene organization of the chicken mitochondrial genome: A novel gene order in higher vertebrates. *Journal of Molecular Biology* 212:599–634.
- Felsenstein, J. 1985. Confidence limits on phylogenies: An approach using the bootstrap. *Evolution* 39:783–791.
- Fleischer, R. C., C. E. McIntosh, C. L. Tarr. 1998. Evolution on a volcanic conveyor belt: Using phylogeographic reconstructions and K-Ar-based ages of the Hawaiian Islands to estimate molecular evolutionary rates. *Molecular Ecology* 7:533–545.

- Fleming, M. A., and J. A. Cook. 2002. Phylogeography of endemic ermine (*Mustela erminea*) in southeast Alaska. *Molecular Ecology* 11:795–807.
- Glenn, T. C. 1997. Genetic bottlenecks in long-lived vertebrates: Mitochondrial and microsatellite DNA variation in American alligators and Whooping Cranes. Ph.D. dissertation, University of Maryland, College Park.
- Green, D. M. 2005. Designatable units for status assessment of endangered species. *Conservation Biology* 19:1813–1820.
- Greene, E., W. Davison, and V. R. Muehter. 1998. Steller's Jay (*Cyanocitta stelleri*). In *The Birds of North America*, no. 343 (A. Poole and F. Gill, Eds.). Academy of Natural Sciences, Philadelphia, and American Ornithologists' Union, Washington, D.C.
- Griswold, C. K., and A. J. Baker. 2002. Time to the most recent common ancestor and divergence times of populations of Common Chaffinches (*Fringilla coelebs*) in Europe and North Africa: Insights into Pleistocene refugia and current levels of migration. *Evolution* 56:143–153.
- Harshman, J. 1996. Phylogeny, evolutionary rates, and ducks. Ph.D. dissertation, University of Chicago, Chicago, Illinois.
- Helm-Bychowski, K., and J. Cracraft. 1993. Recovering phylogenetic signal from DNA sequences: Relationships within the corvine assemblage (class Aves) as inferred from complete sequences of mitochondrial DNA cytochrome-*b* gene. *Molecular Biology and Evolution* 10:1196–1214.

- Hetherington, R., J. V. Barrie, R. G. B. Reid, R. MacLeod, and D. J. Smith. 2004. Paleogeography, glacially induced crustal displacement, and late Quaternary coastlines on the continental shelf of British Columbia, Canada. *Quaternary Science Reviews* 23:295–318.
- Heusser, C. J. 1989. North Pacific coastal refugia—The Queen Charlotte Islands in perspective. Pages 91–106 *in* *The Outer Shores* (G. G. E. Scudder and N. Gessler, Eds.). Queen Charlotte Islands Museum Press, Skidgate, Queen Charlotte, British Columbia.
- Hewitt, G. M. 1996. Some genetic consequences of ice ages, and their role in divergence and speciation. *Biological Journal of the Linnean Society* 58:247–276.
- Hickerson, M. J., E. A. Stahl, and H. A. Lessios. 2006. Test for simultaneous divergence using approximate Bayesian computation. *Evolution* 60:2435–2453.
- Hillis, D. M., C. Moritz, and B. K. Mable, Eds. 1996. *Molecular Systematics*, 2nd ed. Sinauer Associates, Sunderland, Massachusetts.
- Huelsenbeck, J. P., and F. Ronquist. 2001. MRBAYES: Bayesian inference of phylogenetic trees. *Bioinformatics* 17:754–755.
- Jackson, J. A., H. R. Ouellet, and B. J. S. Jackson. 2002. Hairy Woodpecker (*Picoides villosus*). *In* *The Birds of North America*, no 702 (A. Poole and F. Gill, Eds.). Birds of North America, Philadelphia.

- Kavanaugh, D. H. 1989. The ground-beetle (Coleoptera: Carabidae) fauna of the Queen Charlotte Islands: Its composition, affinities, and origins. Pages 131–146 in *The Outer Shores* (G. G. E. Scudder and N. Gessler, Eds.). Queen Charlotte Islands Museum Press, Skidgate, Queen Charlotte, British Columbia.
- Kocher, T. D., W. K. Thomas, A. Meyer, S. V. Edwards, S. Pääbo, F. X. Villablanca, and A. C. Wilson. 1989. Dynamics of mitochondrial DNA evolution in animals: Amplification and sequencing with conserved primers. *Proceedings of the National Academy of Sciences USA* 86:6196–6200.
- Kornegay, J. R., T. D. Kocher, L. A. Williams, and A. C. Wilson. 1993. Pathways of lysozyme evolution inferred from the sequences of cytochrome *b* in birds. *Journal of Molecular Evolution* 37:367–379.
- Lacourse, T., R. W. Mathewes, and D. W. Fedje. 2005. Late-glacial vegetation dynamics of the Queen Charlotte Islands and adjacent continental shelf, British Columbia, Canada. *Palaeogeography, Palaeoclimatology, Palaeoecology* 226:36–57.
- Lovette, I. J. 2004. Mitochondrial dating and mixed support for the “2% rule” in birds. *Auk* 121:1–6.
- Maddison, W. P., and L. L. Knowles. 2006. Inferring phylogeny despite incomplete lineage sorting. *Systematic Biology* 55:21–30.
- Mayr, E., and J. Diamond. 2001. *The Birds of Northern Melanesia: Speciation, Ecology, and Biogeography*. Oxford University Press, New York.

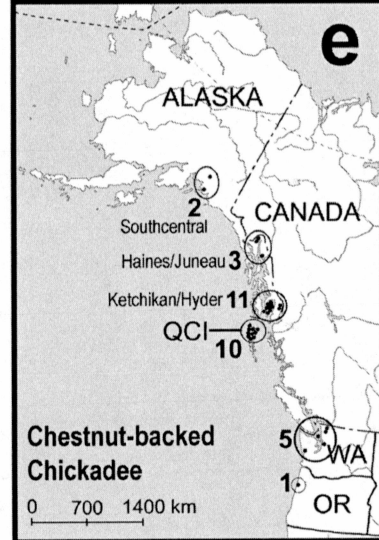
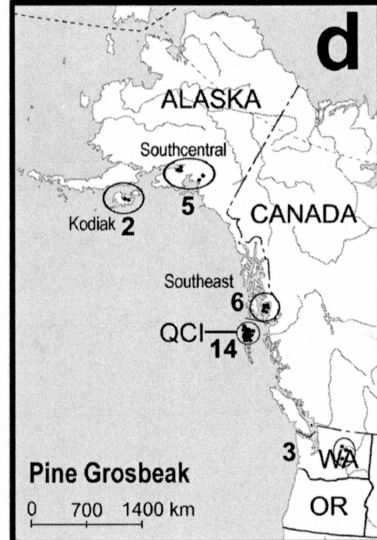
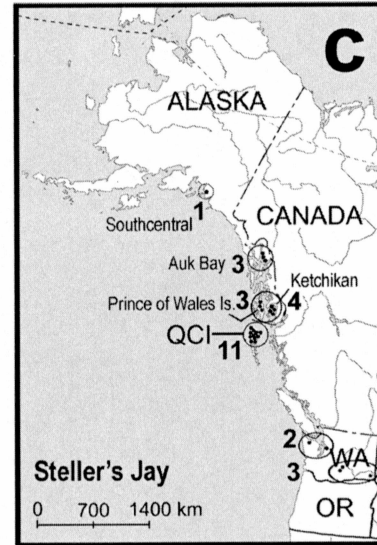
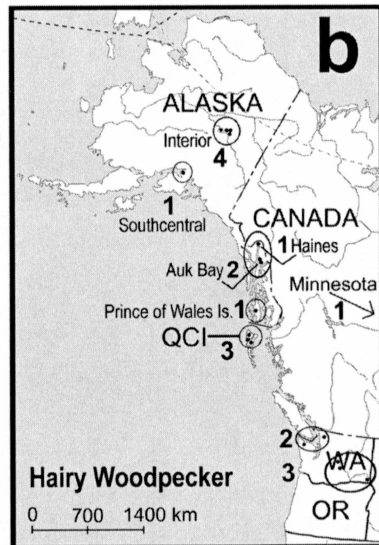
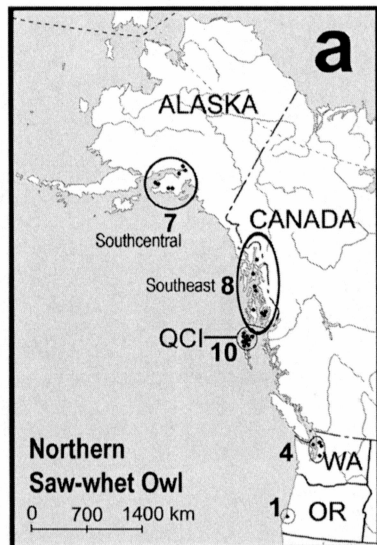
- Moodie, G. E. E., and T. E. Reimchen. 1976. Glacial refugia, endemism, and stickleback populations of the Queen Charlotte Islands, British Columbia. *Canadian Field-Naturalist* 90:471–474.
- Moore, W. S., and V. R. DeFilippis. 1997. The window of taxonomic resolution for phylogenies based on mitochondrial cytochrome *b*. Pages 84–119 in *Avian Molecular Evolution and Systematics* (D. P. Mindell, Ed.). Academic Press, San Diego, California.
- Moritz, C. 1994. Defining ‘evolutionarily significant units’ for conservation. *Trends in Ecology & Evolution* 9:373–375.
- Moritz, C. 2002. Strategies to protect biological diversity and the evolutionary processes that sustain it. *Systematic Biology* 51:238–254.
- Moritz, C., and D. P. Faith. 1998. Comparative phylogeography and the identification of genetically divergent areas for conservation. *Molecular Ecology* 7:419–429.
- Mumme, R. L., M. L. Galatowitsch, P. G. Jabłoński, T. M. Stawarczyk, and J. P. Cygan. 2006. Evolutionary significance of geographic variation in a plumage-based foraging adaptation: An experimental test in the Slate-throated Redstart (*Myioborus miniatus*). *Evolution* 60:1086–1097.
- Ogilvie, R. T. 1989. Disjunct vascular flora of northwestern Vancouver Island in relation to Queen Charlotte Islands’ endemism and Pacific coast refugia. Pages 127–130 in *The Outer Shores* (G. G. E. Scudder and N. Gessler, Eds.). Queen Charlotte Islands Museum Press, Skidgate, Queen Charlotte, British Columbia.

- O'Reilly, P., T. E. Reimchen, R. Beech, and C. Strobeck. 1993. Mitochondrial DNA in *Gasterosteus* and Pleistocene glacial refugium on the Queen Charlotte Islands, British Columbia. *Evolution* 47:678–684.
- Phillimore, A. B., and I. P. F. Owens. 2006. Are subspecies useful in evolutionary and conservation biology? *Proceedings of the Royal Society of London, Series B.* 273:1049–1053.
- Pielou, E. C. 1991. *After the Ice Age: The Return of Life to Glaciated North America.* University of Chicago Press, Chicago, Illinois.
- Posada, D., and T. R. Buckley. 2004. Model selection and model averaging in phylogenetics: Advantages of Akaike information criterion and Bayesian approaches over likelihood ratio tests. *Systematic Biology* 53:793–808.
- Posada, D., and K. A. Crandall. 1998. MODELTEST: Testing the model of DNA substitution. *Bioinformatics* 14:817–818.
- Ronquist, F., and J. P. Huelsenbeck. 2003. MRBAYES 3: Bayesian phylogenetic inference under mixed models. *Bioinformatics* 19:1572–1574.
- Rozas, J., and R. Rozas. 1999. DNASP version 3: An integrated program for molecular population genetics and molecular evolution analysis. *Bioinformatics* 15:174–175.
- Ryder, O. A. 1986. Species conservation and systematics: The dilemma of subspecies. *Trends in Ecology & Evolution* 1:9–10.

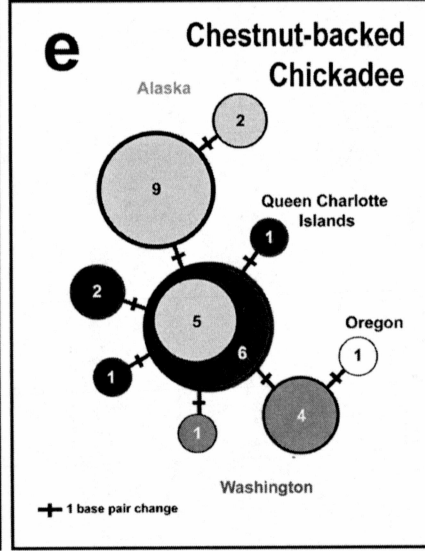
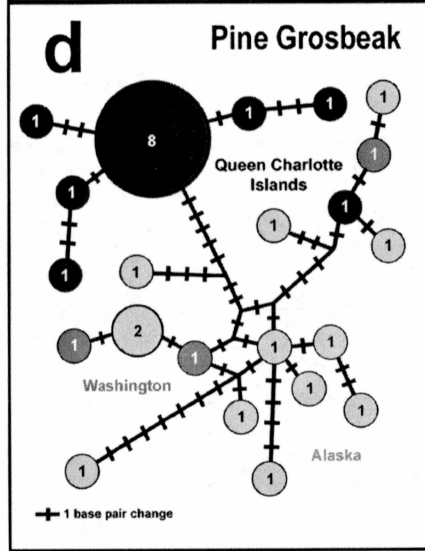
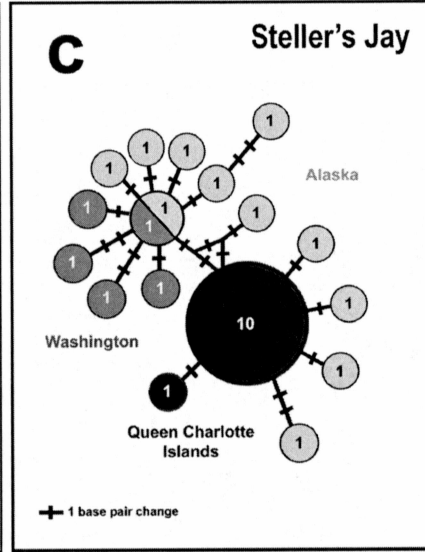
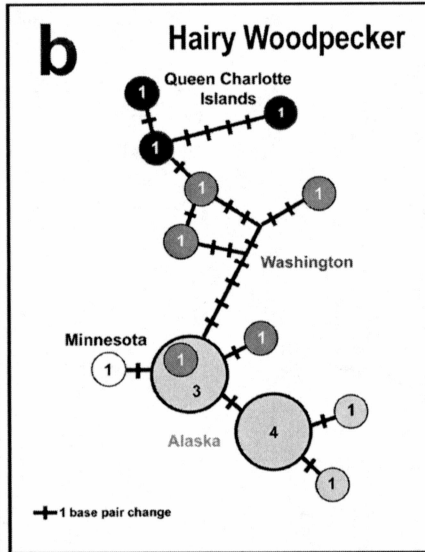
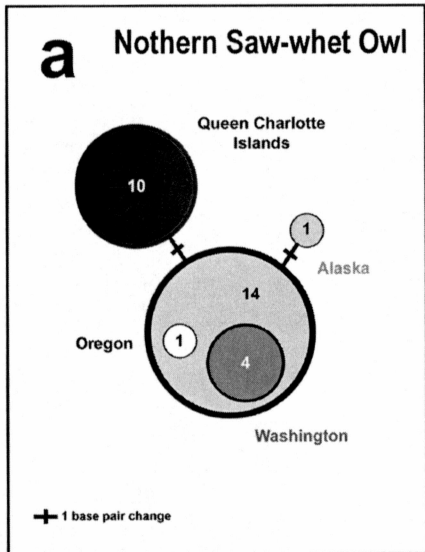
- Schneider, S., D. Roessli, and L. Excoffier. 2000. ARLEQUIN: A Software for Population Genetics Data Analysis, version 2.000. Genetics and Biometry Laboratory, University of Geneva, Geneva, Switzerland.
- Sealy, S. G. 1998. The subspecies of the Northern Saw-whet Owl on the Queen Charlotte Islands: An island endemic and a nonbreeding visitant. *Western Birds* 29:21–28.
- Shields, G. F., and A. C. Wilson. 1987. Calibration of mitochondrial DNA evolution in geese. *Journal of Molecular Evolution* 24:212–217.
- Sonsthagen, S. A., S. L. Talbot, and C. M. White. 2004. Gene flow and genetic characterization of Northern Goshawks breeding in Utah. *Condor* 106:826–836.
- Sutherland Brown, A. 1968. Geology of the Queen Charlotte Islands, British Columbia. British Columbia Department of Mines and Petroleum Resources Bulletin, no. 54.
- Swofford, D. L. 2001. PAUP\*: Phylogenetic Analysis Using Parsimony (\*and Other Methods), version 4.0b10. Sinauer Associates, Sunderland, Massachusetts.
- U.S. Department of the Interior and U.S. Department of Commerce. 1996. Policy regarding the recognition of distinct vertebrate population segments under the endangered species act. *Federal Register* 61:4722–4725.
- Waples, R. S. 1991. Pacific salmon, *Oncorhynchus* spp. and the definition of "species" under the Endangered Species Act. *Marine Fisheries Review* 53:11–22.

Warner, B. G., R. W. Mathewes, and J. J. Clague. 1982. Ice-free conditions on the Queen Charlotte Islands, British Columbia, at the height of the late Wisconsin glaciation. *Science* 218:675–677

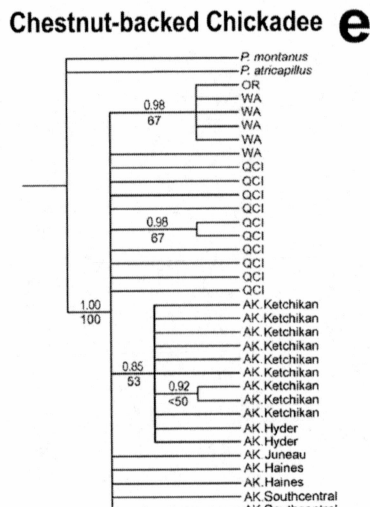
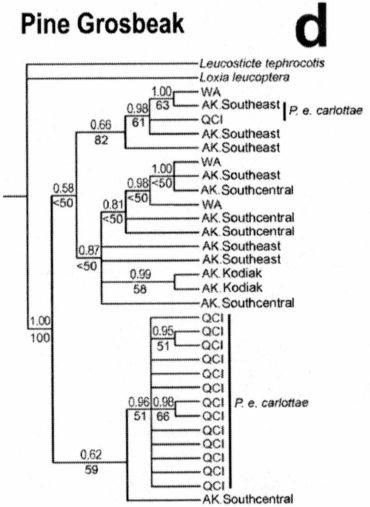
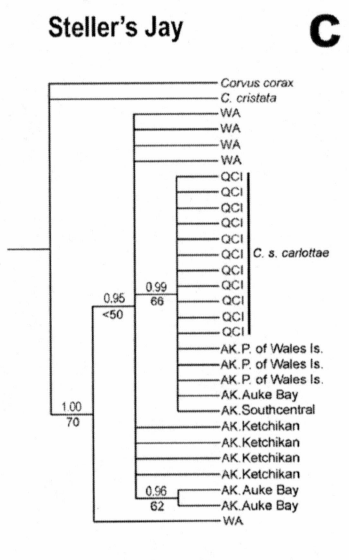
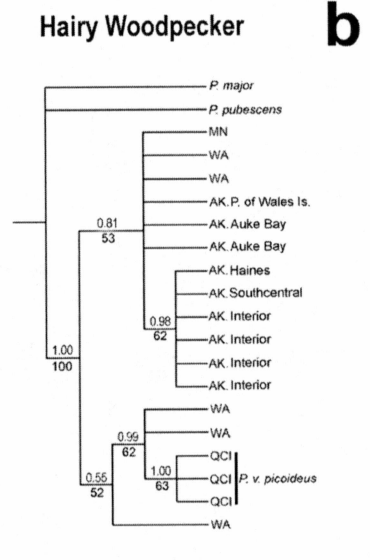
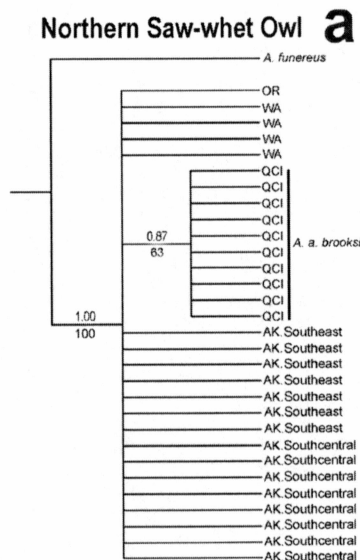




**Fig. 1.1** General sample locations are shown with large circles. Numbers equal sample size within each circle. Black dots indicate approximate locations of individuals and help show sample density in each area.



**Fig. 1.2** Haplotype networks showing the relationships of haplotypes and the number of individuals with each haplotype. Colors indicate sample locations. Black = QCI, Light gray = AK, Dark gray = WA, and White = OR or MN. The size of each circle is proportional to the number of individuals with each haplotype. The length of connecting lines is proportional to the number of base pair differences between haplotypes.



**Fig. 1.3** 50% majority rule consensus trees for all five species. Bayesian and maximum likelihood trees had the same topologies. Numbers above branches are Bayesian posterior probabilities. Numbers below branches are maximum likelihood bootstrap support from 1,000 replications. Sample locations are AK= Alaska, QCI = The Queen Charlotte Is., WA = Washington, OR = Oregon, MN = Minnesota. Subspecies are indicated only where they are important to the discussion.

TABLE 1.1 Population pairwise  $F_{st}$  values (above) and  $P$ -values (below). Values in bold are significant  $P$ -values for  $F_{st}$  with experimentwise  $\alpha = 0.05$  after Bonferroni corrections.

Species	WA: AK	QCI: WA	QCI: AK	QCI: Not QCI
N. Saw-whet Owl	-0.099	1.000	0.920	0.933
	0.991+-0.003	<b>0.000+-0.000</b>	<b>0.000+-0.000</b>	<b>0.000+-0.000</b>
Hairy Woodpecker	0.078	0.000	0.163	0.075
	0.099+-0.025	0.991+-0.003	0.144+-0.031	0.324+-0.051
Steller's Jay	-0.019	0.498	0.389	0.359
	0.991+-0.003	<b>0.000+-0.000</b>	<b>0.000+-0.000</b>	<b>0.000+-0.000</b>
Pine Grosbeak	0.008	0.212	0.008	0.155
	0.671+-0.005	0.122+-0.004	<b>0.001+-0.000</b>	<b>0.001+-0.000</b>
Chestnut-backed Chickadee	0.395	0.374	0.231	0.172
	<b>0.000+-0.000</b>	<b>0.000+-0.000</b>	0.018+-0.018	<b>0.009+-0.009</b>

TABLE 1.2 Analysis of molecular variance (AMOVA) among and within populations for all five species. These numbers are the percent of total genetic variation explained by among-population versus within-population variation.

Species	Among populations	Within populations
Northern Saw-whet Owl	90.96%	9.04%
Hairy Woodpecker	9.06%	90.94%
Steller's Jay	30.47%	69.53%
Pine Grosbeak	14.56%	85.44%
Chestnut-backed Chickadee	31.64%	68.36%

## APPENDIX 1

Voucher numbers and GenBank accessions.

Species	Museum <sup>a</sup>	Catalog numbers	GenBank accession
<i>Aegolius acadicus</i>	UAM	5488, 5851, 6500, 6501, 6901, 6904, 8989-90, 9180-81, 13949, 13996, 14940, 17882-83, 17957, 19042, 19474, 19479, 19481-85, 10153-54.	EU075383-EU075412
	UWBM	C. D. Spaw 5022, 67021, 67190, 68205.	
<i>Picoides villosus</i>	UAM	6994, 7579, 9378, 11035, 11540-41, 13077, 14017, 14096-97, 15188-89, 17705.	EU075502-EU075519
	UWBM	50088, 59091, 62606, 62629, 62643.	
<i>Cyanocitta stelleri</i>	UAM	6046-48, 8507-09, 8878, 8986, 8961, 9292-93, 10099, 10138, 10173, 10199, 11199, 11711, 12435, 12444, 13138, 13498, 13929.	EU075413-EU075439
	UWBM	43187, 58632, 59042, 62608, 63692.	
<i>Pinicola enucleator</i>	UAM	6479, 6483, 6649, 6737, 6745, 6758, 8501-04, 8532, 8794, 9264-66, 10157, 10174-75, 11040, 11285-86, 11287, 11653, 13086, 15182, 17958-59.	EU075440-EU075469
	UWBM	D. R. Froehlich 176, 60576, 60608.	
<i>Poecile rufescens</i>	UAM	6494, 8365-69, 11162, 11203, 11315-16, 11537, 13158-59, 15109-10, 15396, 15421, 17563, 17576, 17706-07, 17746, 17884, 17961-64.	EU075470-EU075501
	UWBM	47924, 62616, 62642, 63698, 71208.	

<sup>a</sup> University of Alaska Museum; University of Washington Burke Museum.

## CHAPTER 2

HOW MIGRATORY THRUSHES CONQUERED NORTHERN NORTH AMERICA:  
A COMMUNITY GENETICS APPROACH<sup>2</sup>

2.1 ABSTRACT.—Five thrush species (Turdidae) successfully colonized North America at high latitudes: Hermit Thrush (*Catharus guttatus*), Swainson's Thrush (*C. ustulatus*), Gray-cheeked Thrush (*C. minimus*), Veery (*C. fuscescens*), and American Robin (*Turdus migratorius*). These species have overlapping, cross-continental breeding ranges and similar ecological niches in northern woodland communities. They have mutualistic relationships with these woodlands (as insectivores and seed-dispersing frugivores) and, as each others' closest relatives, may be interspecific competitors. Population genetics can inform us about how these five similar lineages successfully colonized northern North America to become integral members of high-latitude forest communities (this type of study is termed community genetics). Given their similarities, did all five thrush species colonize North America in the same way? We sequenced mitochondrial cytochrome *b* to assess genetic structure and coalescence of lineages across the continent with samples from northwestern and northeastern North America. We also sought signals of historic population expansion. Results

---

<sup>2</sup>Topp, C. M., C. L. Pruett, K. G. McCracken, and K. Winker (in preparation). How migratory thrushes conquered North America: a community genetics approach. *Molecular Ecology*.

indicated that there are at least two patterns of successful colonization among these five species. Hermit and Swainson's thrushes had deep divergences between continental (occurring across most of northern North America) and Pacific clades (occurring along the Pacific coast), probably reflecting shared historic vicariance. The other three species had shallow phylogenies between eastern and western sampling locations. However, coalescent analyses of eastern and western divergences indicated that among these species as many as five divergence events occurred. Divergence *within* both Hermit and Swainson's thrushes resembled divergence *between* Gray-cheeked Thrush and Veery and probably occurred during a similar period. Historic population expansion was found in Gray-cheeked Thrushes and Pacific and continental clades of Hermit and Swainson's thrushes. We conclude that these five thrush species, despite their ecological similarities, colonized North America in different ways.

Key words: approximate Bayesian computation, community genetics, cytochrome *b*, mtDNA, North American thrushes, msBayes, Turdidae.

## 2.2 INTRODUCTION

It has been suggested that the North American avifauna is a composite of species with different colonization and isolation histories because multiple phylogeographic



patterns are seen in many currently co-distributed species (Zink 1996, Avise 2000, Carstens et al. 2005). However, closely related and ecologically similar species may be more tightly associated with each other over time compared to groups of co-occurring species that are ecologically varied (Richman and Price 1992, Webb 2000, Webb et al. 2002, Lovette and Hochachka 2006).

In this study we examined five migratory thrush species with breeding ranges across North America: Hermit Thrush (*Catharus guttatus*), Swainson's Thrush (*C. ustulatus*), Gray-cheeked Thrush (*C. minimus*), Veery (*C. fuscescens*), and American Robin (*Turdus migratorius*). Their breeding ranges are mostly or partly overlapping (Fig. 2.1), and the species are members of the same northern woodland bird assemblages (Jones and Donovan 1996, AOU 1998, Sallabanks and James 1999, Mack and Yong 2000, Lowther et al. 2001, Maskoff 2005). They are each others' closest relatives in these communities, excluding Bicknell's Thrush (*C. bicknelli*), which we did not include because it has a small breeding range only on the eastern side of the continent (AOU 1998, Rimmer et al. 2001, Klicka et al. 2004, Winker and Pruett 2006).

The five species chosen for this study occur in a variety of woodlands and fill – on a community scale – similar niches as forest mutualists (insectivores, seasonal frugivores, and seed dispersers); they are likely to be each others' closest competitors in these communities (Bent 1949, Jones and Donovan 1996, Sallabanks and James 1999, Mack and Yong 2000, Lowther et al. 2001, Maskoff 2005). Population genetics paired with the known ecology of these species can inform us about how these five similar but

independent lineages successfully colonized North America to become integral members of high-latitude forest communities. This combination of ecology and population genetics is sometimes termed community genetics (Antonovics 1992, Agrawal 2003).

Because of the close evolutionary history, ecological similarity, and trans-continental colonization success of these five species, we hypothesized that they might share similar colonization patterns and histories across northern North America. Did these five thrush species conquer North America in the same way? Many transcontinental vertebrate species and species complexes have a pattern of mtDNA genetic divergence across North America, with a split between a western coastal lineage and an eastern lineage (Milot et al. 2000, Omland et al. 2000, Arbogast and Kenagy 2001, Kimura et al. 2002, Peters et al. 2005, Ruegg and Smith 2002). This pattern has largely been regarded as a result of Pleistocene glacial cycles and the accompanying climatic and ecological changes (Pielou 1991, Arbogast and Kenagy 2001, Weir and Schluter 2004).

Given this pattern of western versus eastern mtDNA genetic breaks seen in several North American vertebrates, our hypothesis of a shared pattern of continental colonization among these similar thrushes can be expanded to include an expectation that the shared pattern may be one of 'divide-and-conquer,' i.e., eastern and western genetic clades may be involved in the transcontinental conquering of North America by these thrushes. Specifically, we asked three questions: (1) Did these five ecologically

similar, co-distributed thrush species colonize North America in the same way, showing similar patterns of expansion? (2) Is there a pattern of genetic divergence between eastern and western populations, as suggested by other vertebrate studies? (3) Do coalescent events, such as lineage divergence, between eastern and western populations occur at similar times, and do these match historic glacial events?

### 2.3 METHODS

*Sampling and mtDNA sequencing.*— The five migratory North American thrush species in this study represent all of the thrushes that are distributed across North America at high latitudes, where they have mostly or partly overlapping breeding ranges (Fig. 2.1). Our study design was to sample thrush assemblages on each side of the continent to understand continental-scale patterns; finding finer-scale phenomena such as where contact zones might be located between possible eastern versus western clades was not one of our goals. The mtDNA gene cytochrome *b* was sequenced because it is a well-studied gene with a fairly constant rate of evolution and has proven useful in many phylogeographic and population genetic studies (Moore and DeFilippis 1997, Avise 2000).

For comparisons across the continent of North America we used two main sample regions along the northern coasts: Eastern = Nova Scotia (NvSc) and Newfoundland (Newf), Canada; and Western = interior Alaska (AK); Southeast Alaska (SE AK); Hyder, Alaska (Hyder); Queen Charlotte Islands, Canada (QCI); and Washington state

(WA; Fig. 2.1). Specimen voucher numbers and GenBank accession numbers are listed in Appendix 2.

Total genomic DNA was extracted from muscle tissue following Glenn (1997) or DNeasy DNA purification kit protocols (Qiagen, Valencia, California). DNA was amplified for most or all of cytochrome *b* using the reverse primer H16064 (Harshman 1996) and the following forward primers: L14703 (C. Huddleston pers. comm.) for Hermit Thrush and Gray-cheeked Thrush (1,143 bp); L14841 (Kocher et al. 1989) for Veery (1,045 bp); and L1650ND5 (Winker and Pruett 2006) for Swainson's Thrush (1,094 bp) and American Robin (1,143 bp). All amplifications were performed using *Taq* DNA Polymerase with buffer B (Promega Corporation, Madison, WI) and standard polymerase chain reaction (PCR) protocols (Hillis et al. 1996). Samples were purified with PEG precipitation and cycle sequenced using Big Dye Terminator 3.1 (Applied Biosystems Inc., Foster City, CA). The amplified cycle-sequenced product was cleaned using sephadex purification columns and sequenced in both directions using standard protocols on an ABI 373, 3100, or 3130*xl* automated sequencer (Applied Biosystems Inc., Foster City, CA). Sequences are available upon request from the author.

*Summary statistics and haplotype networks.*—Mitochondrial sequence data were edited, aligned, and checked for stop codons indicative of nonfunctional nuclear copies using Sequencher 4.7 (Gene Codes Corp., Ann Arbor, MI). Sequence data were blasted on GenBank to ensure that the closest matches were avian mitochondrial cytochrome *b*. Using DnaSP version 4.20.2 (<http://www.ub.es/dnasp/>; Rozas et al. 2003), sequences

were examined for variable base pairs, haplotype variation (H), segregating sites (S), haplotype diversity (h), and nucleotide diversity per site ( $\pi$ ). Statistical parsimony networks were made with TCS 1.21 (<http://darwin.uvigo.es/software/tcs/html>; Clement et al. 2000) to visualize haplotype relationships.

*Phylogenetic analysis.*— Based on preliminary analyses, we noted that a pattern of deep divergence within Hermit and Swainson's thrushes appeared to be similar in pattern and possibly in divergence time to that occurring between Gray-cheeked Thrush and Veery. Therefore, separately from our within-species analyses of eastern and western populations, we also conducted analyses to understand this apparently similar historic divergence event.

The best-fit maximum-likelihood (ML) model of molecular evolution for each species was selected using ML scores from PAUP\* 4.0b10 (Swofford 2001) and the Akaike Information Criterion (AIC) for model selection as implemented in Modeltest 3.6 (<http://darwin.uvigo.es/software/modeltest.html>; Posada and Crandall 1998, Posada and Buckley 2004). The best-fit maximum likelihood models were used in reconstructing phylogenetic trees for each species: HKY, American Robin and Gray-cheeked Thrush; TrN, Veery and combination of Gray-cheeked Thrush and Veery; TrN+I, Hermit Thrush; and K81uf+I, Swainson's Thrush (Posada and Crandall 1998).

These models were implemented to reconstruct phylogenetic trees for each species in MrBayes 3.1.2 (<http://mrbayes.csit.fsu.edu>; Huelsenbeck and Ronquist 2001, Ronquist and Huelsenbeck 2003, Altekar et al. 2004). Trees were rooted with closely

related outgroup taxa; outgroup sequences were acquired from GenBank or from UA Museum specimens (GenBank accession numbers available upon request). Four independent runs starting from random trees were used for each species to ensure that the Markov chain converged on the optimal likelihood value. Trees were sampled every 10,000 generations, and the analyses were run for 8 million generations. All trees sampled before the Markov chain plateaued were discarded (the burnin), and remaining trees were used to approximate posterior probabilities for each phylogeny (Huelsenbeck and Ronquist 2001). A burnin of 100,000 generations was sufficient in all species. The remaining 791 trees were then imported into PAUP\* 4.0b10 (Swofford 2001), where 50% majority rule consensus trees were made with the posterior probabilities of each clade recorded as the percentage of that clade occurring among all the sampled trees (Huelsenbeck and Ronquist 2001).

*Historic population changes.*— $R_2$  and Fu's  $F_s$  statistics, as implemented in DnaSP 4.20.2 (Rozas et al. 2003, Romis-Onsins and Rozas 2002), were used to assess past changes in population size. We chose  $R_2$  and Fu's  $F_s$  because they are more powerful tests than statistics based on mismatch distributions, and  $R_2$  is also better for small sample sizes (Romis-Onsins and Rozas 2002). The probability of our results under a model of constant population size was determined in DnaSP version 4.20.2 (Rozas et al. 2003) with 1,000 coalescent simulations based on observed  $\theta$  ( $2N_e\mu$ ) per gene, where  $N_e$  is the effective population size and  $\mu$  is the mutation rate per sequence per generation.

*Coalescent analyses.*—To estimate divergence times we used the coalescent program Isolation with Migration (IM version 10.10.07; [http://lifesci.rutgers.edu/~heylab/Heylab Software.htm](http://lifesci.rutgers.edu/~heylab/Heylab%20Software.htm); Hey and Nielsen 2004), which uses a Markov chain Monte Carlo (MCMC) approach. IM incorporates effective population sizes and migration rates while simultaneously estimating divergence time. Using IM we estimated the time of divergence ( $t$ ) between eastern and western populations and the time to most recent common ancestor (TMRCA). These parameters were scaled to the neutral mutation rate, making it possible to directly compare results between species. We compared  $t$ -values among the five species to examine coalescent patterns between eastern and western populations. To determine whether divergence dates *within* Hermit and Swainson's thrushes were similar to the divergence *between* Gray-cheeked Thrushes and Veeries we compared estimates of TMRCA.

To make a rough estimate of the timing of divergences, we converted  $t$ -values and TMRCA-values from IM to time in years using the estimated mutation rate of about 2% divergence per million years for mtDNA in birds (Hey and Nielsen 2004, Lovette 2004). This estimate is imprecise, but it enables us to roughly date the historic contexts of these divergences (Ho et al. 2005, Pereira and Baker 2006).

At least three runs were performed in IM for each species: an initial run to estimate appropriate priors and then two additional independent runs with identical conditions but different random number seeds to check for convergence. The runs with the highest effective sample sizes (ESS) were chosen to report results.

To set an upper prior for  $t$ , we assumed that the time since divergence could not be older than TMRCA, and we used the upper 95% confidence value from preliminary runs to set the upper bound for  $t$  in each species (Peters et al. 2007). We ran IM for a different number of total steps for each data set based on preliminary runs to ensure that the lowest ESS values were at least 500 (Hey and Nielson 2004): Hermit and Swainson's thrushes were run with 15,000,000 steps; Gray-cheeked Thrushes, Veeries, and American Robins were run using 10,000,000 steps; Gray-cheeked Thrushes and Veeries combined as one dataset were run for 20,000,000 steps. For all species we used a burnin of 1,000,000 steps.

*Testing divergence hypotheses.*—To test the hypothesis of simultaneous divergence or colonization times across North America, we used msBayes (<http://www.msBayes.sourceforge.net/>; Hickerson et al. 2006, 2007). This program uses an approximate Bayesian computational (ABC) framework that tests for simultaneous divergence across multiple co-distributed taxon pairs (taxon pair = taxon with two populations) using a hierarchical model that incorporates intrinsic variation such as ancestral coalescence and among-taxon demographic histories (Hickerson et al. 2006, 2007). This method allows for the simultaneous estimation of three hyper-parameters that characterize the mean ( $E[\tau]$ ), variability ( $\Omega$ ), and number of separate divergence events ( $\Psi$ ) across multiple population pairs (Hickerson et al. 2006, 2007). ABC obtains these estimates by simulating data and their summary statistics from the joint prior distribution under a model and then sampling from the resulting joint posterior distribution using



probabilities based on the similarity between the summary statistic vector for the observed versus the simulated data (Hickerson et al. 2006, 2007). These methods are effective even with population sample sizes of five or less (Hickerson et al. 2007).

We examined two data sets with msBayes: (1) the five thrush taxa with eastern and western populations, and (2) a three 'taxon' set of Hermit Thrush and Swainson's Thrush clades and Gray-cheeked Thrushes and Veeries combined. The three 'taxon' set was based on the observation that the pattern of deep divergence within Hermit and Swainson's thrushes appeared to be similar to the divergence between Gray-cheeked Thrushes and Veeries. The divergent clades within Hermit and Swainson's thrushes did not perfectly match eastern and western sampling locations, so for this three 'taxon' analysis we used the clades labeled continental and Pacific, based on sample locations. More details are given in Results.

We ran two million simulations in msBayes using the following starting parameters for the upper and lower bounds of prior distributions:  $\theta$  lower = 0.5 (default),  $\theta$  upper = 20.0 for the five taxa data set, and  $\theta$  upper = 5.0 for the three 'taxon' data set (based on the highest  $\pi_{\mathcal{N}}$  from observed summary statistics as recommended by Hickerson et al. 2006),  $\tau$  upper = 10.0 for the five taxa data set, and  $\tau$  upper = 15.0 for the three 'taxon' data set (based on relatively recent divergence in the last 1 or 1.5 million years), migration rate upper = 10.0 (some migration is possible), recombination rate upper = 0.0 (mtDNA has no recombination), and ancestral population size upper = 0.5 (default). We report joint posterior estimates based on the summary statistic vector  $\mathbf{D}$  that

includes 13 summary statistics ( $\pi$ ,  $\pi_{net}$ ,  $\pi_b$ ,  $\pi_w$ ,  $\pi_{w1}$ ,  $\pi_{w2}$ ,  $\theta_W$ ,  $\theta_{W1}$ ,  $\theta_{W2}$ , Tajima's  $D$ ,  $\text{Var}[\pi-\theta_W]$ ,  $\text{Var}[\pi-\theta_W]_1$ ,  $\text{Var}[\pi-\theta_W]_2$ ) per taxon pair. We sampled the posterior distribution with a tolerance of 0.0005 and 0.00025, which yielded estimates based on 1000 and 500 draws from the joint posterior, given that there were two million simulated draws from the joint prior. Results are presented using a tolerance of 0.00025, because this sampling parameter showed better resolution in the posterior probability density graph (peaks were more cleanly shaped), although results were very similar for both tolerance levels.

## 2.4 RESULTS

*Genetic variation.*—The five thrush species had varying degrees of intraspecific genetic diversity, with the lowest number of haplotypes being 5 and the highest number 24 (Table 2.1). The number of segregating sites ( $S$ ), haplotype diversity ( $h$ ), and nucleotide diversity per site ( $\pi$ ) varied accordingly for each species (Table 2.1) with most species showing high values. For all five species, more than 50% of the nucleotide substitutions were third position synonymous changes.

Statistical parsimony networks showed two broad haplotype and phylogenetic patterns among these five species (Fig. 2.2). Hermit and Swainson's thrushes had two deeply divergent lineages separated by 21 and 14 nucleotide differences, respectively (we will hereafter refer to them as continental, primarily from eastern and interior Alaska locations, and Pacific clades, primarily from southeast Alaska), whereas Gray-checked Thrushes, Veeries, and American Robins showed no differences greater than

two nucleotide substitutions between closest haplotypes (Fig. 2.2). However, each species had a slightly different pattern of relationships between eastern and western sampled haplotypes, and the two species with divergent lineages (Hermit and Swainson's thrushes) had haplotype occurrences from both the continental and Pacific clades in western populations (Fig. 2.2). In both species, individuals from Hyder, Alaska possessed haplotypes from both sides of these deep divergences, suggesting a zone of contact between continental and Pacific populations (Fig. 2.2a and 2.2b). The continental Hermit Thrush clade included one individual from Hyder and all the Washington, interior Alaska, and eastern individuals, whereas the Pacific clade had the majority of the Hyder and all of the QCI individuals (Fig. 2.2a). The continental Swainson's Thrush clade contained five individuals from Hyder and all of the eastern individuals, and the Pacific clade had all the QCI and WA individuals and the remaining four Hyder birds (Fig. 2.2b).

*Phylogenetic patterns.*—The same two general patterns observed among the five species' haplotype networks (Fig. 2.2) were also observed in the Bayesian phylogenetic trees: Hermit and Swainson's thrushes had two divergent lineages with high posterior probabilities, and the other species had much less structure (Fig. 2.2 and 2.3). A Bayesian tree of the relationship between the Gray-cheeked Thrush and the Veery also had high posterior probabilities for nodes associated with the species-level split (Fig. 2.3). The Bayesian phylogram of Gray-cheeked Thrushes and Veeries combined

showed how similar their pattern of divergence was to the within-species divergences observed in Hermit and Swainson's thrushes (Fig. 2.3).

*Historic population changes.*—The two statistics,  $R_2$  and Fu's  $F_s$ , had similar results under a model of constant population size, and where they differed we refer to the  $R_2$  results because this is a more reliable statistic for small sample sizes (Romis-Onsins and Rozas 2002; Table 2.1). Significant deviations from constant population size (a signal of recent rapid population expansion) were indicated for a combined analysis of Gray-cheeked Thrush sampling locations and its western population, the eastern population of Swainson's Thrushes, and both the continental and Pacific clades of Hermit and Swainson's thrushes (Table 2.1). Only the Gray-cheeked Thrush had a significant signal of recent rapid population expansion for an entire species (Table 2.1). Veeries and American Robins did not differ significantly from a model of historic population stability in any of their populations (Table 2.1). The eastern population of American Robins, all Hermit Thrushes combined, and the western population of Hermit Thrushes had very high probabilities ( $P > 0.94$ ) of observed  $R_2$  values under a model of historic population stability (Table 2.1).

*Coalescent analyses.*—IM analyses showed strongly unimodal posterior distributions for  $t$  and TMRCA for all thrushes. Both the Hermit Thrush and American Robin divergences between eastern and western populations had posterior distributions of  $t$  with tails that did not approach zero, effectively making our upper 95% confidence intervals infinity; however they also had clearly defined unimodal peaks. Changing the

priors made little difference (not shown). In both cases we used the upper 95% confidence value estimated for TMRCA to set an upper bound on  $t$  because we assumed  $t$  could not be greater than TMRCA (Fig. 2.4). The Hermit Thrush posterior distribution for  $t$  clearly peaked over a range similar to the other species' eastern-versus-western population  $t$ -values, and the distribution values that went to infinity were flat but very close to zero (not shown). This result for the Hermit Thrush suggests that the eastern population diverged recently, within the last 100,000 years before present (ybp), from the western population (all individuals sampled from the west of North America regardless of clade). However, given other evidence, such as the Hyder-region contact zone and likelihood of gene flow, we cannot rule out the possibility that this divergence occurred much earlier ( $\leq 1.5$  million ybp; Table 2.2, Fig. 2.4).

Confidence intervals for TMRCA and  $t$  broadly overlapped in American Robins and Veeries. These species also exhibited little genetic structure, and eastern and western individuals shared haplotypes, suggesting little or no divergence across the continent (Table 2.2, Figs. 2.2 and 2.4). Gray-cheeked Thrushes had a TMRCA date with 95% confidence interval that overlapped the confidence intervals of  $t$  (Fig. 2.4), and eastern and western populations did not share haplotypes. This indicates an older divergence event between eastern and western Gray-cheeked Thrushes than in the American Robin or the Veery (Figs. 2.2 and 2.4). Hermit and Swainson's thrushes showed deep divergences (TMRCA = 1.03 million ybp and 750,000 ybp, respectively) between continental and Pacific clades, but continental clade haplotypes were found in eastern

and western populations, resulting in a shallow divergence ( $t = 70,000$  ybp and  $60,000$  ybp, respectively) between the two sides of the continent (Table 2.2, Figs. 2.2 and 2.4). These results parallel results from our other analyses for these two species. The TMRCA 95% confidence interval ( $490,000 - 925,000$  ybp) between the Gray-cheeked Thrush and Veery overlapped the TMRCA 95% confidence intervals for divergence between continental and Pacific clades within the Hermit Thrush ( $720,000$  ybp –  $1.5$  million ybp) and within Swainson's Thrush ( $500,000$  ybp –  $1.14$  million ybp), which also parallels our other results (Table 2.2, Figs. 2.3 and 2.4).

*Testing divergence hypotheses.*—For the five thrush species, the ratio of variance to mean divergence time was  $\Omega = 2.15$  (95% quantiles =  $0.94-6.56$ ), which indicated multiple divergence events as estimated in msBayes ( $\Omega = 0$  is expected for a set of population pairs with one divergence event). The number of divergence times across the five taxon pairs was five on the density graph (Fig. 2.5), with the highest point twice as high as all other values; however, there was a medium density flat line across the other values that was slightly higher (around a mode of  $\Psi = 2.36$ ; 95% quantiles =  $1.00-5.00$ ). This means that we can reject the hypothesis of one divergence event and that five is most likely, although there is a possibility that anywhere from two to five divergence events occurred. These results thus do not support a similar pattern of transcontinental colonization of North America for the five thrush species.

Estimates of homogeneity in divergence times for the three 'taxon' dataset of Hermit Thrush, Swainson's Thrush, and Gray-cheeked Thrushes and Veeries combined

yielded a ratio of variance to mean divergence times of  $\Omega = 0.00$  (95% quantiles = 0.00-2.56) and a value for the number of divergence times across taxon pairs of  $\Psi = 1.02$  (95% quantiles = 1.00-2.86), which supports a history of simultaneous divergence between these relatively deep splits (Fig. 2.5).

## 2.5 DISCUSSION

Two primary patterns of continental colonization were found among these five North American thrush species: a shallow divergence between eastern and western populations of Gray-cheeked Thrushes, Veeries, and American Robins, and a relatively deep divergence in Hermit and Swainson's thrushes (Figs. 2.1 and 2.4). These five thrush species also appeared to have five significantly different coalescence events between eastern and western populations. On the other hand, the relatively deep divergences between continental and Pacific clades *within* Hermit and Swainson's thrushes seemed to share a coalescence time with the split *between* the Gray-cheeked Thrush and the Veery (Fig. 2.3). These results indicate that despite their ecological similarity these five thrush species colonized North America in more than one way, with individual, species-level differences and two broad continental patterns.

*Colonization of North America.*—We hypothesized that thrush species with similar ecology would share a pattern of east to west splits in mtDNA as has been shown in other species. However, this pattern was not shared among the five species in our study. Veeries and American Robins had little structure between eastern and western populations (Fig. 2.2d and e). Gray-cheeked Thrushes had no shared haplotypes

between eastern and western populations, but few mutations separated these populations (Fig. 2.2c). These species most likely spread across the continent to their current ranges from single ancestral populations maintained through at least the last glacial maximum.

Hermit and Swainson's thrushes had relatively deep divergences between continental and Pacific clades (Fig. 2.2a and b). These splits did not match exactly with the sampled eastern and western populations; however, this divergence is similar to patterns reported in other studies (Arbogast and Kenagy 2001, Ruegg and Smith 2002, Weir and Schluter 2004). Previous population genetic research on Swainson's Thrushes found mtDNA sequence divergence between Pacific coastal and continental populations with a tension zone of secondary contact between them (Ruegg and Smith 2002, Ruegg et al. 2006, Ruegg 2008). This indicates that Swainson's and Hermit thrushes were likely split into two populations during historic vicariant events and were isolated from one another throughout much of the Pleistocene. After the last glacial maximum, they expanded across the continent into their current ranges and came into secondary contact (Fig. 2.4).

Because all avian species at higher latitudes are expected to have undergone postglacial population expansions, we expected to see relatively low values of  $R_2$  and Fu's  $F_s$  indicating these expansions (Hewitt 1996). However, some populations in our study showed a signal of population stability (Table 2.1). This may partly be due to sampling error due to small sample sizes (e.g., eastern population of the Gray-cheeked Thrush) and the relatively deep splits within species and shared haplotypes in the western populations of Hermit and Swainson's thrushes (Fig. 2.2a and b).



The eastern Swainson's Thrush population had a signal of recent rapid expansion, while the western population did not (Table 2.1). This is consistent with the findings of Ruegg and Smith (2002) whose results showed expansion in continental populations of Swainson's Thrush but not in western coastal populations. This pattern has also been observed in other avian studies (Milot et al. 2000, Peters et al. 2005). However, at the clade, rather than population, scale, our results had both continental and Pacific clades of Swainson's Thrush showing strong signals of expansion, as did both the Hermit Thrush clades (Table 2.1). The continental Swainson's Thrush and Hermit Thrush clades did have lower negative  $F_s$  statistics than the Pacific clades, supporting the possibility that continental clades may have had greater expansion than Pacific clades (Table 2.1).

Gray-cheeked Thrush as a species had a signal of expansion (Table 2.1), as would be expected by a spread across northern North America from a common ancestral population after glacial recession from the last glacial maximum (Fig. 2.1; QEN 1997).

American Robins and Veeries had no signal of population expansion. As the southernmost breeding members of this assemblage, it is possible that populations of these species did not expand significantly following the last glacial maximum.

*Patterns shared with other vertebrates.*—Several other transcontinentally distributed North American bird species exhibit mitochondrial lineage breaks between the northwest coast and lineages found in the rest of their North American range: Yellow Warbler, *Dendroica petechia* (Milot et al. 2000); Common Raven, *Corvus corax*

(Omland et al. 2000); Wilson's Warbler, *Wilsonia pusilla* (Kimura et al. 2002); and Wood Duck, *Aix sponsa* (Peters et al. 2005). This pattern also occurs in some transcontinentally distributed North American mammal species and in mammal and bird species complexes (Arbogast and Kenagy 2001, Weir and Schluter 2004): black bear, *Ursus americanus* (Wooding and Ward 1997, Stone and Cook 2000); northern flying squirrel, *Glaucomys sabrinus* (Arbogast 1999a); tree squirrels, *Tamiasciurus* species (Arbogast et al. 2001); American Martin, *Martes americana* (Demboski et al. 1999); and red-backed voles, *Clethrionomys* species (Arbogast 1999b). These western-versus-eastern patterns of differentiation are widely considered to be the result of glacial history and corresponding climatic and ecological changes over time (Pielou 1991; Arbogast and Kenagy 2001, Weir and Schluter 2004, Ruegg et al. 2006).

The patterns of divergence found within Hermit and Swainson's thrushes between eastern and western populations and the deep divergence between Pacific coastal and continental clades parallel the results of these other studies (Table 2.2, Figs. 2.2 and 2.4). East-versus-west population divergences ( $t$ ) (as opposed to clade-level differences) in all five North American thrush species were relatively shallow, with all species most likely diverging in the last 150,000 years before present (ybp), which was similar to dates determined for east-versus-west splits between populations of Yellow Warblers (100,000-7,000 ybp; Milot et al. 2000), Wilson's Warblers (62,500-33,654 ybp; Kimura et al. 2002), and Wood Ducks (124,000-10,000 ybp; Peters et al. 2005; Table 2.2, Fig. 2.4).

The relatively deep splits between clades within Hermit and Swainson's thrushes and the split between the Gray-cheeked Thrush and Veery (TMRCA) had much larger 95% confidence intervals than the shallow, population-level divergence events, but generally appeared to occur within the last 1.5 million to 400,000 thousand years (Table 2.2, Figs. 2.3 and 2.4). These divergence levels are similar to those found between Pacific coastal and continental clades in Common Ravens (2 million ybp; Omland et al. 2000), black bears (1.8 million ybp; Wooding and Ward 1997), and northern flying squirrels (1.3 million to 750,000 thousand ybp; Arbogast 1999a). Similar to our results, Outlaw et al. (2003) dated the divergence between the Gray-cheeked Thrush and Veery to a range of 507,000 to 213,000 ybp, which overlaps the lower end of our 95% confidence interval for divergence between these two species.

Our estimate of divergence time (TMRCA) between the continental and Pacific clades in Swainson's Thrush is much older than that estimated by Ruegg and Smith (2002), who estimated the time of divergence between these two groups as 10,000 ybp. Differences in time estimates could be due to using different genes and therefore different estimates of mutation rate. However, Ruegg and Smith (2002) used the mitochondrial control region with an estimated divergence rate of 14.8% per million years, which is a much higher mutation rate than is usually assumed for passerines (Marshall and Baker 1997, Bensch et al. 1999, Griswold and Baker 2002, Bulgin et al. 2003, Perez-Tris et al. 2004, Davis et al. 2006). Thus we feel that they underestimated the divergence time between clades in Swainson's Thrushes.

*Divergences among thrushes.*—When we compared eastern and western population divergences among these five thrush species, the divergence dates ( $t$ ) all occurred within the last 300,000 years (Table 2.2, Fig. 2.4). However, our analysis of these five species indicated that there was more than one and maybe as many as five different divergence or vicariance events for the five thrush species (Table 2.1, Fig. 2.4). It thus seems quite possible (Fig. 2.5) that each species had its own unique history of colonization across North America even though they inhabit similar or identical northern communities.

At a deeper level, when we examined the relatively deep events of cladogenesis in our datasets, the continental and Pacific clade splits within Hermit and Swainson's thrushes and the divergence between the Gray-cheeked Thrush and Veery occurred during a similar time interval (Table 2.2, Figs. 2.3 and 2.4). This suggests a shared divergence period within Hermit and Swainson's thrushes and between the Gray-cheeked Thrush and Veery.

It is now generally agreed that glacial cycling in the Pleistocene created much of the observed interspecific and sister-species level divergence in many songbird species, especially in the northern hemisphere (Avise and Walker 1998, Johnson and Cicero 2004, Weir and Schluter 2004, Lovette 2005). Our results indicate that divergence events apparent in some thrush species also probably occurred within the Pleistocene (Table 2.2, Fig. 2.4). Paleocological data suggest that forest habitat may have been present in North America to the east and west just south of the last glacial maximum's

southern expanse, while the center of the continent was grassland and desert (Pielou 1991, Crowley 1995, QEN 1997). For forest-dependant species this could have been a significant barrier to gene flow and may have isolated them into forest refugia. When the glaciers receded to the north, species could expand into their current ranges (Pielou 1991, Weir and Schluter 2004, Ruegg et al. 2006). This description of the last glacial maximum and expansion into new ranges may describe recently diverged species or populations. However, older glacial cycles in the Pliocene and the early- to mid-Pleistocene may have affected populations and species in similar ways, and thus created patterns such as those seen in the deeply divergent clades within Hermit and Swainson's thrushes and between the Gray-cheeked Thrush and Veery.

Weir and Schluter (2004) found that many bird species complexes in boreal regions diverged into east (taiga) and west (pacific coast) clades about  $1.2 (\pm 0.10)$  million ybp. Because ice sheets did not form a single ice mass until the second half of the Pleistocene, it is likely that long periods of boreal fragmentation into eastern and western regions occurred during the early- to mid-Pleistocene (1.8-0.8 million ybp) when glaciers began to increase (Barendregt and Irving 1998, Weir and Schluter 2004). The 95% confidence interval for estimated dates of divergence (TMRCA) between clades in Hermit and Swainson's thrushes and between the Gray-cheeked Thrush and Veery overlap this period. Contemporary gene flow between Hermit and Swainson's thrush clades (e.g., in Hyder, Alaska) and their relative lack of phenotypic differentiation as opposed to Gray-cheeked Thrushes and Veeries, suggest that these

two lineages within each species did not sufficiently differentiate during previous separation to achieve reproductive isolation and full speciation.

*Conclusion.*—From the perspective of community genetics, these five North American thrushes became widespread members of northern forests in different ways. Multiple factors, from the local, ecological level (e.g., competition), to regional, evolutionary levels (e.g., climatic and glacial changes), were likely involved in producing the current cross-continental ranges observed in these five ecologically similar North American thrushes. It is of interest that there are species-level patterns but that two overriding patterns are also evident — i.e., a lack of homogeneity at one organizational level (five separate divergence levels within species is most probable) with evidence of concordance around two general patterns at another, among-species level. This suggests that the processes that brought about these present assemblages are neither fixed, causing all species to have the same continental colonization pattern, nor completely stochastic, in that there are two patterns of divergence.

## 2.6 ACKNOWLEDGMENTS

This project was supported by the University of Alaska Museum and an anonymous donor. Genetic samples were supplied by the University of Alaska Museum and the University of Washington Burke Museum. Thanks to K. Winker, R. W. Dickerman, D. D. Gibson, A. B. Johnson, and T. M. Braile for technical assistance and field sampling. Thanks also to J. L. Peters and T. Roberts for consultation and to M. J. Hickerson and

Naoki Takebayashi for assistance and guidance on using msBayes. For preliminary lab work I thank K. G. McCracken, C. Barger, and C. L. Pruett. For helpful comments and discussion I thank C. L. Pruett, E. Wilner, and K. Winker.

## 2.7 LITERATURE CITED

- Altekar, G., S. Dwarkadas, J. P. Huelsenbeck, and F. Ronquist. 2004. Parallel Metropolis-coupled Markov chain Monte Carlo for Bayesian phylogenetic inference. *Bioinformatics* 20:407-415.
- Agrawal, A. A. 2003. Community genetics: new insights into community ecology by integrating population genetics. *Ecology* 84: 543-544.
- American Ornithologist's Union (AOU). 1998. Check-list of North American Birds, 7th ed. American Ornithologist's Union, Washington, D.C.
- Antonovics, J. 1992. Toward community genetics. Pages 426-429 in *Plant resistance to herbivores and pathogens: ecology, evolution, and genetics* (R. S. Fritz and E. L. Simms, Eds.). University of Chicago Press, Chicago, Illinois, USA.
- Arbogast, B. S. 1999a. Mitochondrial DNA phylogeography of the New World flying squirrels (*Glaucomys*): implication for Pleistocene biogeography. *Journal of Mammalogy* 80:142-155.
- Arbogast, B. S., 1999b. Comparative phylogeography of North American boreal mammals. Ph.D. dissertation, Wake Forest University, Winston-Salem, NC, USA.

- Arbogast, B. S., R. A. Browne, and P. D. Weigl. 2001. Evolutionary genetics and Pleistocene biogeography of North American tree squirrels (*Tamiasciurus*). *Journal of Mammalogy* 82:302-319.
- Arbogast, B. S., and G. J. Kenagy. 2001. Comparative phylogeography as an integrative approach to historical biogeography. *Journal of Biogeography* 28:819-825.
- Avise, J. C. 2000. *Phylogeography: The History and Formation of Species*. Harvard University Press, Cambridge, Massachusetts.
- Avise, J. C., and D. Walker. 1998. Pleistocene phylogeographic effects on avian populations and the speciation process. *Proceedings of the Royal Society of London Series B, Biological Sciences* 265:457-463.
- Barendregt, R. W., and E. Irving. 1998. Changes in the extent of North American ice sheets during the late Cenozoic. *Canadian Journal of Earth Science* 35:504-509.
- Bensch, S., T. Andersson, and S. Akesson. 1999. Morphological and molecular variation across a migratory divide in willow warblers, *Phylloscopus trochilus*. *Evolution* 53:1925-1935.
- Bent, A. C. 1949. *Life histories of North American thrushes, kinglets and their allies*. Smithsonian Institution, United States National Museum Bulletin 196.
- Bulgin, N. L., H. L. Gibbs, P. Vickery, and A. J. Baker. 2003. Ancestral polymorphisms in genetic markers obscure detection of evolutionarily distinct populations in the endangered Florida grasshopper sparrow (*Ammodramus savannarum floridanus*). *Molecular Ecology* 12:831-844.



Carstens, B. C., S. J. Brunsfeld, J. R. Demboski, J. M. Good, and J. Sullivan. 2005.

Investigating the evolutionary history of the Pacific Northwest mesic forest ecosystem: hypothesis testing within a comparative phylogeographic framework. *Evolution* 59:1639-1652.

Clement, M., D. Posada and K. A. Crandall. 2000. TCS: a computer program to

estimate gene genealogies. *Molecular Ecology* 9:1657-1660.

Crowley, T. J. 1995. Ice-age terrestrial carbon changes revisited. *Global*

*Biogeochemical Cycles* 9:377-389.

Davis, L. A., E. H. Roalson, K. L. Cornell, K. D. McClanahan, and M. S. Webster.

2006. Genetic divergence and migration patterns in North American passerine bird: implications for evolution and conservation. *Molecular Ecology* 15:2141-2152.

Demboski, J. R., K. D. Stone, and J. A. Cook. 1999. Further perspectives on the Haida

Gwaii glacial refugium. *Evolution* 53:2008-2010.

Glenn, T. 1997. Genetic bottlenecks in long-lived vertebrates: Mitochondrial and

microsatellite DNA variation in American alligators and whooping cranes. Ph.D. dissertation, University of Maryland, College Park.

Griswold, C. K., and A. J. Baker. 2002. Time to the most recent common ancestor and

divergence times of populations of common chaffinches (*Fringilla coelebs*) in Europe and North Africa: insights into Pleistocene refugia and current levels of migration. *Evolution* 56:143-153.

- Harshman, J. 1996. Phylogeny, evolutionary rates, and ducks. Ph.D. dissertation, University of Chicago, Chicago Illinois.
- Hewitt, G. M. 1996. Some genetic consequences of ice ages, and their role in divergence and speciation. *Biological Journal of the Linnean Society* 58:247-276.
- Hey, J. and R. Nielsen. 2004. Multilocus methods for estimating population sizes, migration rates and divergence time, with applications to the divergence of *Drosophila pseudoobscura* and *D. persimilis*. *Genetics* 167:747-760.
- Hickerson, M. J., E. A. Stahl, and H. A. Lessios. 2006. Test for simultaneous divergence using approximate Bayesian computation. *Evolution* 60:2435-2453.
- Hickerson, M. J., E. A. Stahl, and N. Takebayashi. 2007. MsBayes: Pipeline for testing comparative phylogeographic histories using hierarchical approximate Bayesian computation. *BioMed Central Bioinformatics* 8:268. Available from: <http://www.biomedcentral.com/1471-2105/8/268>.
- Hillis, D. M., C. Moritz, B. K. Mable. 1996. *Molecular Systematics*, 2nd ed. Sinauer Associates, Inc., Sunderland, Massachusetts.
- Ho, S. Y. W., M. J. Phillips, A. Cooper, and A. J. Drummond. 2005. Time Dependency of molecular rate estimates and systematic overestimation of recent divergence times. *Molecular Biology and Evolution* 22:1561-1568.
- Huelsenbeck, J. P., and F. Ronquist. 2001. MRBAYES: Bayesian inferences of phylogenetic trees. *Bioinformatics* 17:754-755.

- Johnson, N. K., and C. Cicero. 2004. New mitochondrial DNA data affirm the importance of Pleistocene speciation in North American birds. *Evolution* 58:1122-1130.
- Jones, P. W., and T. M. Donovan. 1996. Hermit Thrush (*Catharus guttatus*). In *The Birds of North America Online*, no. 261(A. Poole, Ed.). Ithaca: Cornell Lab of Ornithology; Retrieved from *The Birds of North America Online*: <http://bna.birds.cornell.edu/bna/species/261>.
- Kimura, M., S. M. Clegg, I. J. Lovette, D. J. Holder, D. J. Girman, B. Mila, P. Wade, and T. B. Smith. 2002. Phylogeographical approaches to assessing demographic connectivity between breeding and overwintering regions in a Nearctic-Neotropical warbler (*Wilsonia pusilla*). *Molecular Ecology* 11:1605-1616.
- Klicka, J., G. Voelker, and G. M. Spellman. 2004. A molecular phylogenetic analysis of the "true thrushes" (Aves: Turdinae). *Molecular Phylogenetics and Evolution* 34:486-500.
- Kocher, T. D., W. K. Thomas, A. Meyer, S. V. Edwards, S. Pääbo, F. X. Villablanca, and A. C. Wilson. 1989. Dynamics of mitochondrial DNA evolution in animals: amplification and sequencing with conserved primers. *Proceedings of the National Academy of Sciences USA* 86:6196-6200.
- Lovette, I. J. 2004. Mitochondrial dating and mixed support for the "2% rule" in birds. *Auk* 121:1-6.

- Lovette., I. J. 2005. Glacial cycles and the tempo of avian speciation. *Trends in Ecology and Evolution* 20:57-59.
- Lovette, I. J., and W. M. Hochachka. 2006. Simultaneous effects of phylogenetic niche conservatism and competition on avian community structure. *Ecology* 87:S14-S28.
- Lowther, P. E., C. C. Rimmer, B. Kessel, S. L. Johnson, and W. G. Ellison. 2001. Gray-cheeked Thrush (*Catharus minimus*). In *The Birds of North America Online*, no. 591 (A. Poole, Ed.). Ithaca: Cornell Lab of Ornithology; Retrieved from *The Birds of North America Online*: <http://bna.birds.cornell.edu/bna/species/591>.
- Mack, D. E., and W. Yong. 2000. Swainson's Thrush (*Catharus ustulatus*). In *The Birds of North American Online*, no. 540 (A. Poole, Ed.). Ithaca: Cornell Lab of Ornithology; Retrieved from *The Birds of North America Online*: <http://bna.birds.cornell.edu/bna/species/540>.
- Marshall, H. D., and A. J. Baker. 1997. Structural conservation and variation in the mitochondrial control region of fringilline finches (*Fringilla* spp.) and greenfinch (*Carduelis chloris*). *Molecular Biology and Evolution* 14:173-184.
- Maskoff, W. 2005. Veery (*Catharus fuscescens*). In *The Birds of North America Online*, no. 142 (A. Poole, Ed.). Ithaca: Cornell Lab of Ornithology; Retrieved from *The Birds of North America Online*: <http://bna.birds.cornell.edu/bna/species/142>.

- Milot, E., H. L. Gibbs, K. A. Hobson. 2000. Phylogeography and genetic structure of northern populations of the yellow warbler (*Dendroica petechia*). *Molecular Ecology* 9:667-681.
- Moore, W. W., and V. R. DeFilippis. 1997. The window of taxonomic resolution for phylogenies based on mitochondrial cytochrome *b*. Pages 84-115 in *Avian Molecular Evolution and Systematics* (D. P. Mindell, Ed.). Academic Press, San Diego, California.
- Omland, K. E., C. L. Tarr, W. I. Boarman, J. M. Marzluff, and R. C. Fleisher. 2000. Cryptic genetic variation and paraphyly in ravens. *Proceedings of the Royal Society of London, Series B, Biological Sciences* 267:2475-2482.
- Outlaw, D. C., G. Voelker, B. Mila, and D. J. Girman. 2003. Evolution of long-distance migration in and historical biogeography of *Catharus* thrushes: a molecular phylogenetic approach. *Auk* 120:299-310.
- Pereira, S. L. and A. J. Baker. 2006. A Mitogenomic timescale for birds detects variable phylogenetic rates of molecular evolution and refutes the standard molecular clock. *Molecular Biology and Evolution* 23:1731-1740.
- Perez-Tris, J., S. Bensch, R. Carbonell, A. J. Helbig, and J. L. Telleria. 2004. Historical diversification of migration patterns in a passerine bird. *Evolution* 58:1819-1832.

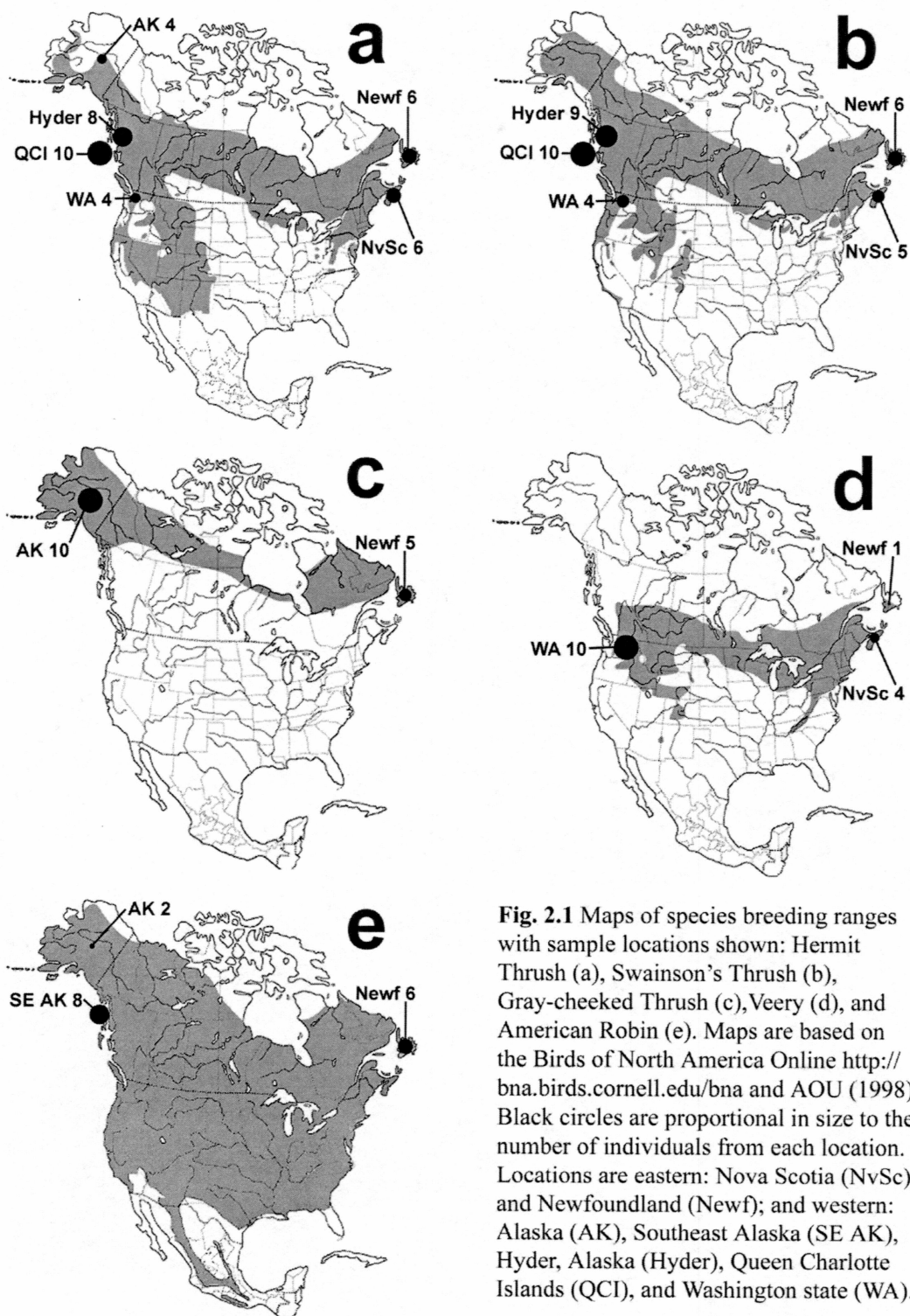
- Peters, J. L., W. Gretes, and K. E. Omland. 2005. Late Pleistocene divergence between eastern and western populations of wood ducks (*Aix sponsa*) inferred by the 'isolation with migration' coalescent method. *Molecular Ecology* 14:3407-3418.
- Peters, J. L., Y. Zhuravlev, I. Fefelov, A. Logie, and K. E. Omland. 2007. Nuclear loci and coalescent methods support ancient hybridization as cause of mitochondrial paraphyly between Gadwall and Falcated Duck (*Anas* spp.). *Evolution* 61:1992-2006.
- Pielou, E. C. 1991. *After the Ice Age: the Return of Life to Glaciated North America*. University of Chicago Press, Illinois.
- Posada, D., and T. R. Buckley. 2004. Model selection and model averaging in phylogenetics: advantages of Akaike Information Criterion and Bayesian approaches over likelihood ratio tests. *Systematic Biology* 53:793-808.
- Posada, D., and K. A. Crandall. 1998. Modeltest: Testing the model of DNA substitution. *Bioinformatics* 14:817-818.
- Quaternary Environments Network (QEN). 1997. Review and atlas of palaeovegetation: preliminary land ecosystem maps of the world since the last glacial maximum (J. M. Adams and H. Faure Eds.). Oak Ridge National Laboratory, TN, USA. Available from: <http://www.esd.ornl.gov/projects/qen/adams1.html>.
- Richman, A. D., and T. Price. 1992. Evolution of ecological differences in the Old World leaf warblers. *Nature* 355:817-821.

- Rimmer, C. C., K. P. McFarland, W. G. Ellison, and J. E. Goetz. 2001. Bicknell's Thrush (*Catharus bicknelli*). In The Birds of North America Online, no. 592 (A. Poole, Ed.). Ithaca: Cornell Lab of Ornithology; Retrieved from The Birds of North America Online: <http://bna.birds.cornell.edu/bna/species/592>.
- Romis-Onsins, S. E., and J. Rozas. 2002. Statistical properties of neutrality tests against population growth. *Molecular Biology and Evolution* 19:2092-2100.
- Ronquist, F., and J. P. Huelsenbeck. 2003. MRBAYES 3: Bayesian phylogenetic inference under mixed models. *Bioinformatics* 19:1572-1574.
- Rozas, J., J. C. Sanchez-DelBarrio, X. Messeguer and R. Rozas. 2003. DnaSP, DNA polymorphism analyses by the coalescent and other methods. *Bioinformatics* 19:2496-2497.
- Ruegg, K. C. 2008. Genetic, morphological, and ecological characterization of a hybrid zone that spans a migratory divide. *Evolution* 62:452-466.
- Ruegg, K. C., R. J. Hijmans, and C. Moritz. 2006. Climate change and the origin of migratory pathways in the Swainson's Thrush (*Catharus ustulatus*). *Journal of Biogeography* 33:1172-1182.
- Ruegg, K. C., and T. B. Smith. 2002. Not as the crow flies: A historical explanation for circuitous migration in the Swainson's Thrush (*Catharus ustulatus*). *Proceedings of the Royal Society of London, Series B, Biological Sciences* 269:1375-1381.

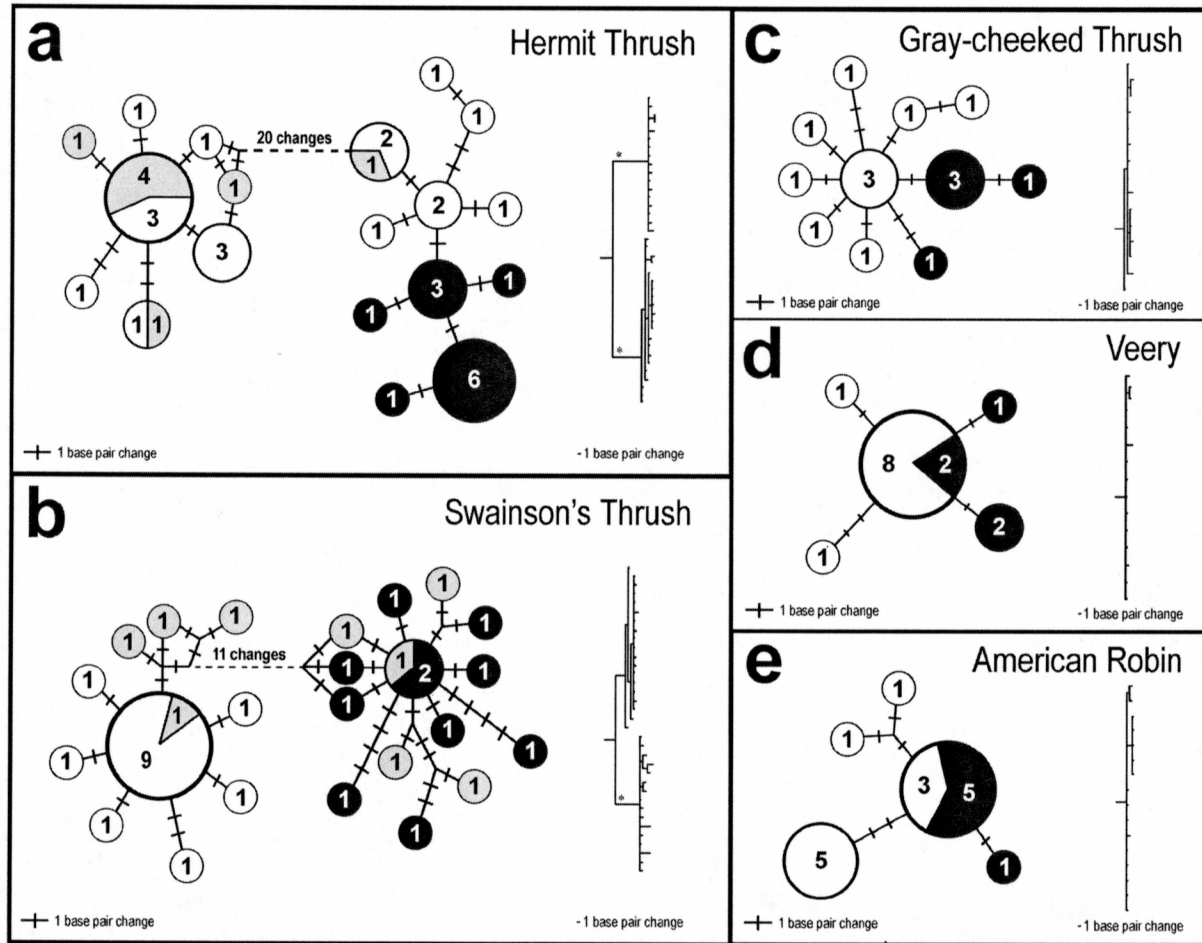
- Sallabanks, R., and F. C. James. 1999. American Robin (*Turdus migratorius*). In The Birds of North America Online, no. 462 (A. Poole, Ed.). Ithaca: Cornell Lab of Ornithology; Retrieved from The Birds of North America Online: <http://bna.birds.cornell.edu/bna/species/462>.
- Stone, K. D., and J. A. Cook. 2000. Phylogeography of black bears (*Ursus americanus*) of the Pacific Northwest. *Canadian Journal of Zoology* 78:1218-1223.
- Swofford, D. L. 2001. PAUP\*: phylogenetic analysis using parsimony (\* and other methods), ver. 4.0b10. Sinauer Associates Inc., Sunderland, MA.
- Webb, C. O. 2000. Exploring the phylogenetic structure of ecological communities: an example from rain forest trees. *American Naturalist* 156:145-155.
- Webb, C. O., D. D. Ackerly, M. A. McPeck, and M. J. Donoghue. 2002. Phylogenies and community ecology. *Annual Reviews in Ecology and Systematics* 33:475-505.
- Weir, J. T. and D. Schluter. 2004. Ice sheets promote speciation in boreal birds. *Proceedings of the Royal Society of London. Series B, Biological Sciences* 271:1881-1887.
- Winker, K., and C. L. Pruett. 2006. Seasonal migration, speciation, and morphological convergence in the genus *Catharus* (Turdidae). *Auk* 123:1052-1068.
- Wooding, S. and R. Ward. 1997. Phylogeography and Pleistocene evolution in the North American black bear. *Molecular Biology and Evolution* 14:1096-1105.



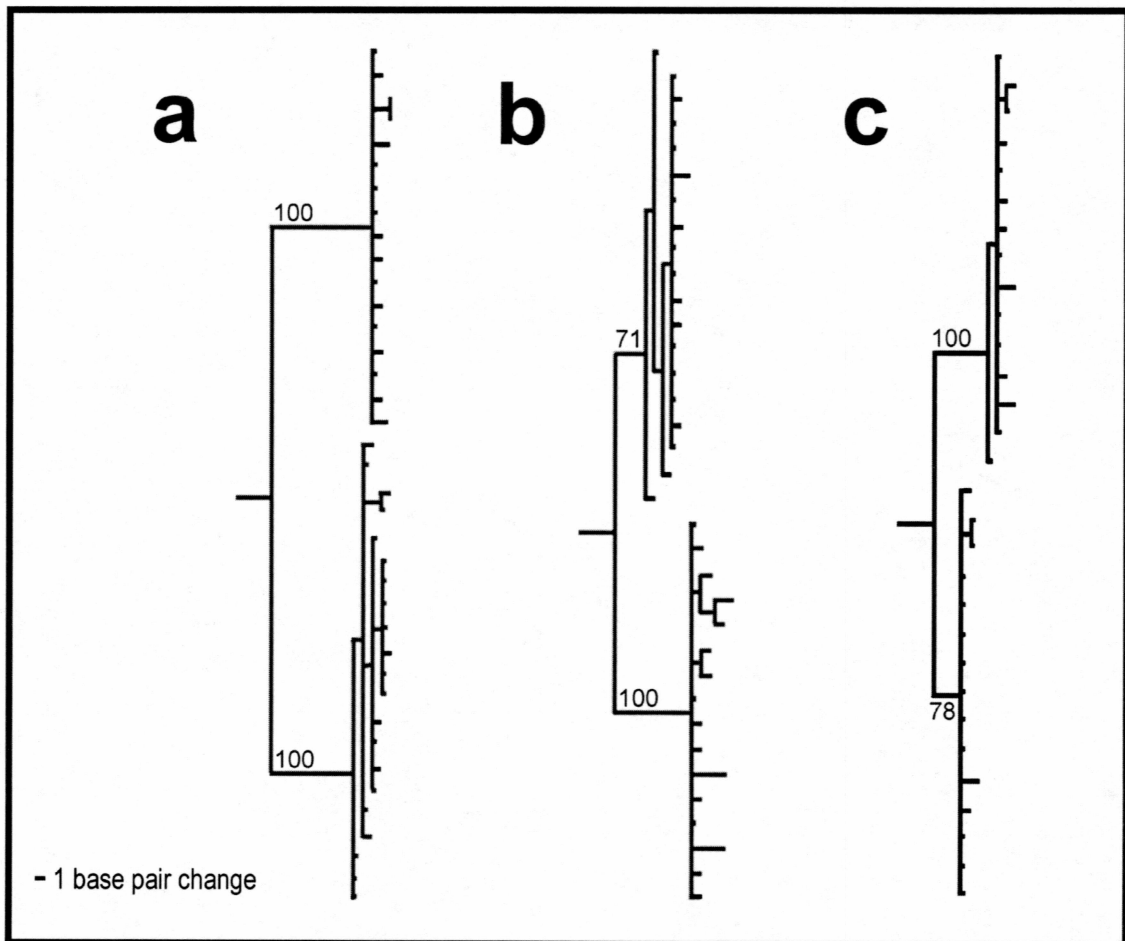
Zink, R. M. 1996. Comparative phylogeography of North American birds. *Evolution* 50:308-317.



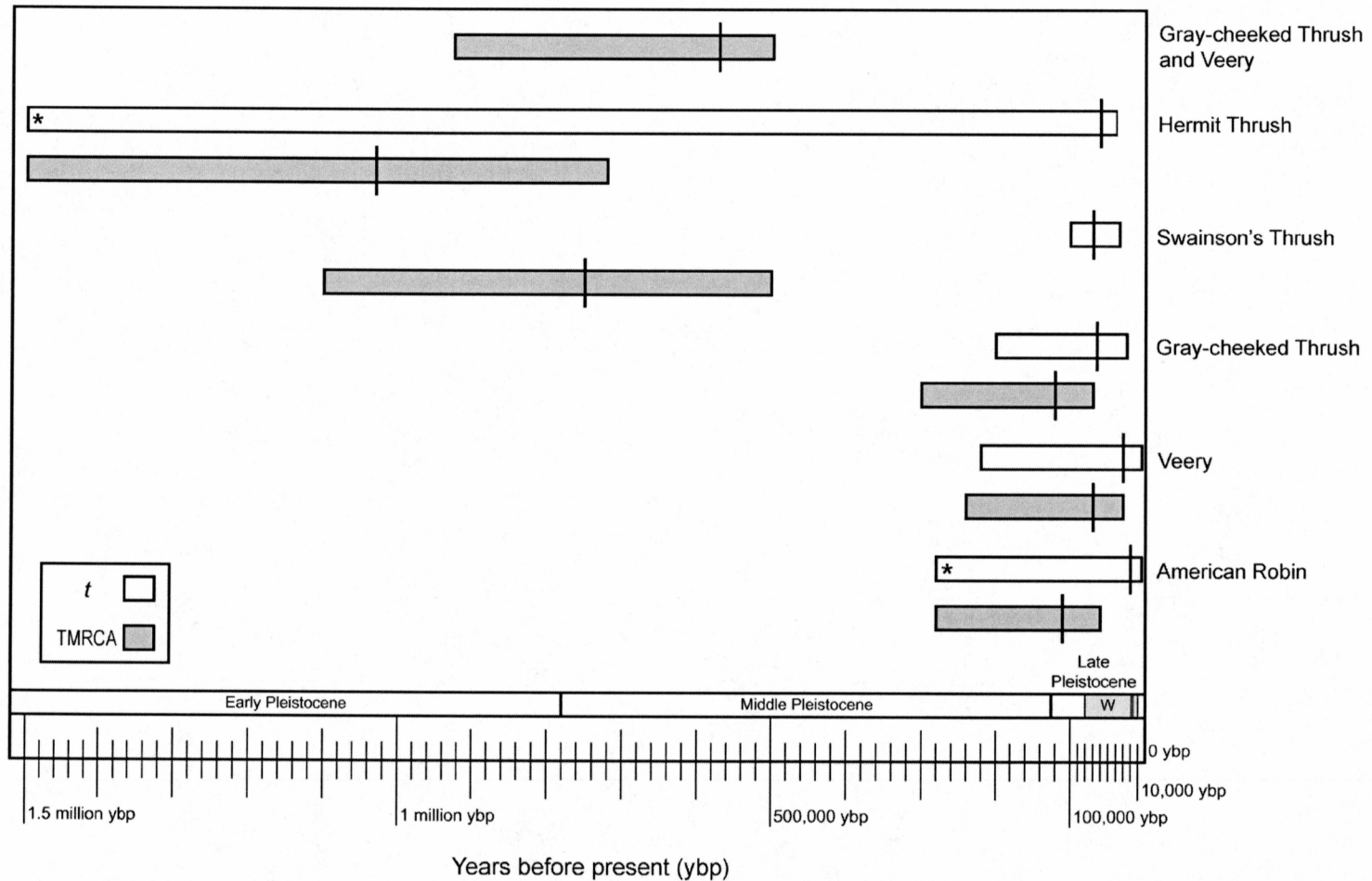
**Fig. 2.1** Maps of species breeding ranges with sample locations shown: Hermit Thrush (a), Swainson's Thrush (b), Gray-cheeked Thrush (c), Veery (d), and American Robin (e). Maps are based on the Birds of North America Online <http://bna.birds.cornell.edu/bna> and AOU (1998). Black circles are proportional in size to the number of individuals from each location. Locations are eastern: Nova Scotia (NvSc), and Newfoundland (Newf); and western: Alaska (AK), Southeast Alaska (SE AK), Hyder, Alaska (Hyder), Queen Charlotte Islands (QCI), and Washington state (WA).



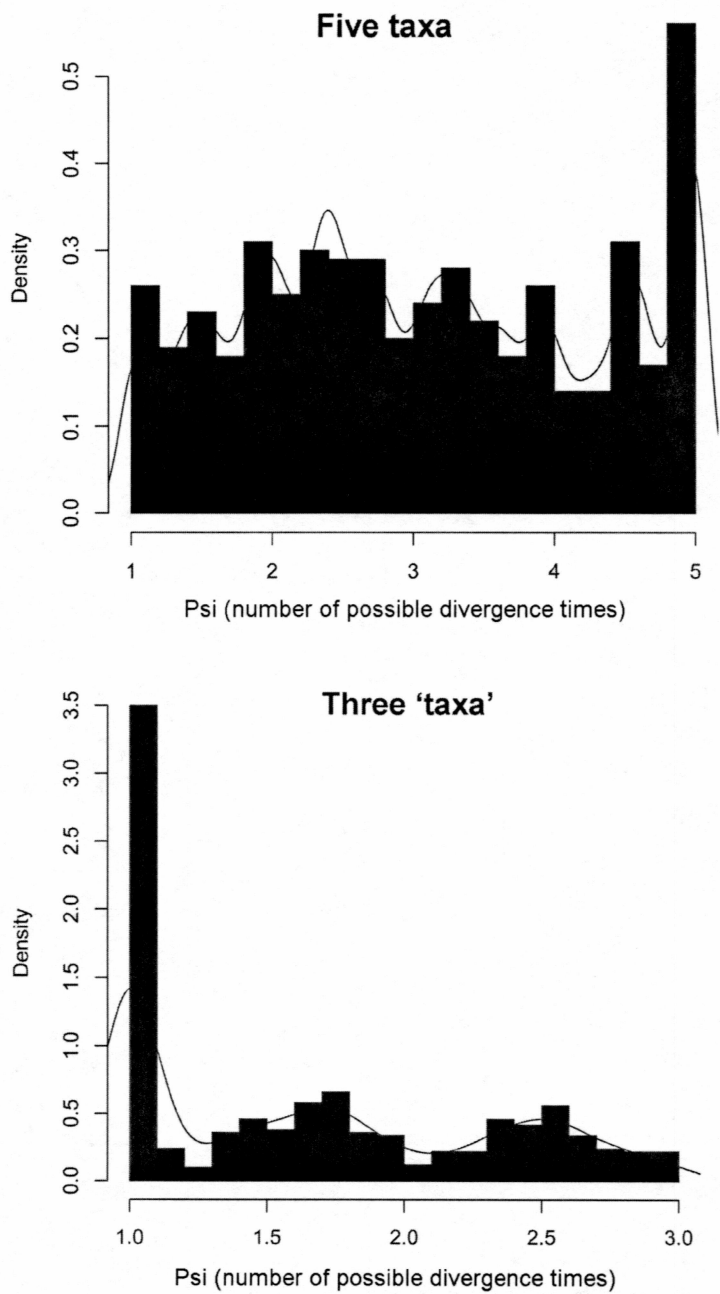
**Fig. 2.2** Statistical parsimony networks showing haplotype relationships and the number of individuals with each haplotype. Shading indicates general sampling areas in North America; black = eastern, white = western, and gray = Hyder, Alaska. The size of each circle is proportional to the number of individuals with each haplotype. The length of connecting lines is proportional to the number of base pair differences between haplotypes. The phylograms on the right are sized proportionally to each other. Phylogeographically important nodes with Bayesian posterior probabilities of 1.0 are shown with an asterisk.



**Fig. 2.3** Phylograms of deep divergences: Hermit Thrush (a), Swainson's Thrush (b), and Gray-cheeked Thrush (top clade) and Veery (bottom clade) combined (c). Hermit Thrush and Swainson's Thrush clades are Pacific (top) and continental (bottom). Phylogeographically important nodes have Bayesian posterior probabilities next to them.



**Fig. 2.4** Divergence time in years before present converted from smoothed IM values of divergence times with 95% confidence intervals for  $t$  (white bars) and TMRCA (gray bars), assuming 2% sequence divergence per million years for *cyt b* in passerines. Along the bottom is a geological time scale showing different segments of the Pleistocene and the Wisconsin glacial period (W). The last glacial maximum (~18,000 ybp) is shown with a thick line within the late Wisconsin. An asterisk indicates that the upper 95% confidence value was used from TMRCA (see methods).



**Fig. 2.5** msBayes posterior probability graphs of  $\Psi$  (Psi) for the five taxon data set (all five thrush species east-west populations) and the three 'taxon' data set (Hermit Thrush and Swainson's Thrush clades, and Gray-cheeked Thrushes and Veeries combined).

TABLE 2.1 Measures of genetic diversity and historical population size analyses calculated in DnaSP v.4.20.2 (Rozas et al. 2003) for each species total, eastern and western populations, and continental and Pacific clades in species with deep divergences. Measures of diversity are: n = sample number, H = number of haplotypes, S = segregating sites, h = haplotype diversity, and  $\pi$  (per site) = nucleotide diversity.  $R_2$  and Fu's  $F_s$  were used to measure historical population changes. 1,000 coalescent simulations were used to determine the probability of our results under a model of constant population size. Significant results are shown in bold ( $P < 0.05$ ).

Species	n	H	S	h	(SD)	$\pi$ (per site)	(SD)	$R_2$	P ( $R_2$ )	Fu's $F_s$	P (Fu's $F_s$ )
Hermit Thrush	38	19	37	0.93	( $\pm 0.02$ )	0.0118	( $\pm 0.0005$ )	0.18	0.977	-0.06	0.556
East	12	5	4	0.73	( $\pm 0.11$ )	0.0009	( $\pm 0.0002$ )	0.13	0.258	-1.82	0.050
West	26	14	33	0.81	( $\pm 0.04$ )	0.0105	( $\pm 0.0013$ )	0.18	0.943	0.48	0.594
Continental clade	21	11	11	0.90	( $\pm 0.05$ )	0.0019	( $\pm 0.0003$ )	<b>0.08</b>	<b>0.032</b>	<b>-5.34</b>	<b>0.003</b>
Pacific clade	17	8	8	0.82	( $\pm 0.08$ )	0.0013	( $\pm 0.0003$ )	<b>0.09</b>	<b>0.017</b>	<b>-3.73</b>	<b>0.003</b>
Swainson's Thrush	35	24	42	0.92	( $\pm 0.04$ )	0.0088	( $\pm 0.0005$ )	0.10	0.367	<b>-6.92</b>	<b>0.031</b>
East	11	10	19	0.98	( $\pm 0.05$ )	0.0032	( $\pm 0.0007$ )	<b>0.08</b>	<b>0.000</b>	<b>-6.12</b>	<b>0.002</b>
West	24	15	32	0.84	( $\pm 0.08$ )	0.0063	( $\pm 0.0015$ )	0.09	0.154	-3.03	0.115
Continental clade	16	14	24	0.98	( $\pm 0.04$ )	0.0032	( $\pm 0.0006$ )	<b>0.05</b>	<b>0.000</b>	<b>10.21</b>	<b>0.000</b>
Pacific clade	19	10	12	0.74	( $\pm 0.11$ )	0.0014	( $\pm 0.0004$ )	<b>0.06</b>	<b>0.000</b>	<b>-6.28</b>	<b>0.000</b>
Gray-cheeked Thrush	15	11	12	0.94	( $\pm 0.05$ )	0.0018	( $\pm 0.0003$ )	<b>0.07</b>	<b>0.000</b>	<b>-8.11</b>	<b>0.000</b>
East	5	3	4	0.70	( $\pm 0.22$ )	0.0014	( $\pm 0.0006$ )	0.29	0.543	0.28	0.552
West	10	8	8	0.93	( $\pm 0.08$ )	0.0015	( $\pm 0.0003$ )	<b>0.09</b>	<b>0.000</b>	<b>-5.63</b>	<b>0.000</b>
Veery	15	5	5	0.56	( $\pm 0.14$ )	0.0008	( $\pm 0.0003$ )	0.12	0.126	<b>-2.17</b>	<b>0.025</b>
East	5	3	2	0.80	( $\pm 0.16$ )	0.0010	( $\pm 0.0003$ )	0.25	0.331	-0.48	0.236
West	10	3	3	0.38	( $\pm 0.18$ )	0.0006	( $\pm 0.0003$ )	0.21	0.489	-0.46	0.159
American Robin	16	5	6	0.68	( $\pm 0.09$ )	0.0013	( $\pm 0.0003$ )	0.12	0.105	-0.37	0.417
East	6	2	1	0.33	( $\pm 0.22$ )	0.0003	( $\pm 0.0002$ )	0.37	1.000	0.00	0.534
West	10	4	5	0.71	( $\pm 0.12$ )	0.0016	( $\pm 0.0004$ )	0.17	0.296	0.44	0.606

TABLE 2.2 IM values and divergence time converted to years for  $t$  and TMRCA. Top rows are smoothed IM values and 95% confidence intervals scaled to the neutral mutation rate of divergence time ( $t$ ) between eastern and western samples in each species and the time to most recent common ancestor (TMRCA; divergence for clades). Bottom rows are IM values converted to time in years (T) assuming 2% sequence divergence per million years where the mutation rate ( $\mu$ ) is  $1 \times 10^{-8}$  substitutions/site/lineage/year and  $T = L t/\mu$ , where  $L$  = the length of the sequence in base pairs. Numbers in bold are the biologically important divergence measure for each species in describing continent-wide divergence.

Species	$t$	95% low – high	TMRCA	95% low – high
Hermit Thrush	0.65 56,430	0.44 – na* 38,373 – na*	<b>11.79</b> <b>1,031,601</b>	<b>8.26 – 17.12</b> <b>722,240 – 1,498,023</b>
Swainson's Thrush	0.72 65,841	0.39 – 1.67 35,384 – 152,733	<b>8.23</b> <b>752,002</b>	<b>5.44 – 12.50</b> <b>496,810 – 1,142,934</b>
Gray-cheeked Thrush	<b>0.74</b> <b>65,092</b>	<b>0.31 – 2.48</b> <b>27,017 – 216,833</b>	1.37 119,528	0.79 – 3.12 68,714 – 273,123
Veery	<b>0.34</b> <b>32,651</b>	<b>0.08 – 2.30</b> <b>7,291 – 220,450</b>	0.73 69,971	0.34 – 2.51 32,536 – 240,191
American Robin	<b>0.19</b> <b>16,807</b>	<b>0.09 – 3.30</b> <b>8,180 – na*</b>	1.31 114,304	0.62 – 3.25 54,514 – 284,296
Gray-cheeked Thrush and Veery	na	na	<b>5.99</b> <b>572,967</b>	<b>5.11 – 9.66</b> <b>489,234 – 924,641</b>

\* The high 95% confidence values were used from TMRCA because the upper distribution tails for  $t$  did not approach zero.



## APPENDIX 2

Voucher numbers and GenBank accessions.

Species	Museum <sup>a</sup>	Catalog numbers	GenBank accession
<i>Catharus guttatus</i>	UAM	7322, 7564, 9989-93, 9995-8, 10108, 13235, 13415, 14351, 17601, 19819, 19821-2, 19824-6, 20779, 24436-8, 24440-2, 24444-8.	EU619718-EU619755
	UWBM	43131, 62639-40, 74551.	
<i>Catharus ustulatus</i>	UAM	7323, 7523, 7525, 7538, 7540, 7570, 9978-85, 13411, 19829-42, 19844.	EU619756-EU619790
	UWBM	43114, 74064, G. K. Davis 220, G. S. Bergsma 40, W. C. Webb 14.	
<i>Catharus minimus</i>	UAM	7440, 7457-8, 7596, 8965, 12984, 13208, 13405-7, 13410, 14546, 14669, 17814, 19812.	EU619791-EU619805
<i>Catharus fuscescens</i>	UAM	13414, 13416, 19845-7.	EU619806-EU619820
	UWBM	62067-8, 62071, 62073, 62078, 62083-4, 62136, 62144, 62151.	
<i>Turdus migratorius</i>	UAM	7232-3, 14912-3, 13466, 13951, 14128, 14825, 14889, 14938, 24415-20.	EU619821-EU619836

<sup>a</sup> University of Alaska Museum; University of Washington Burke Museum.

## CONCLUSIONS

This research focused on using comparative genetic studies of geographically co-distributed species to evaluate current and historic relationships among northern avian populations and species. Results were expected to help determine conservation implications and to understand aspects of the evolutionary and ecological histories of these avian assemblages. This comparative genetic approach was used to examine two different types of co-distributed bird species: island endemics and thrush species with transcontinental ranges.

*Island endemics.*—I found that phenotypically-described subspecies on the Queen Charlotte Islands (QCI) were genetically unique from mainland populations, and they represented evolutionarily significant units (ESUs). Although the overall pattern showed island divergence from mainland populations, each species had a different divergence time, suggesting independent histories. Results imply that QCI has been an important area for the generation of avian biodiversity below the species level and that it is an important area for the conservation and management of birds in northwestern North America.

*Transcontinental ranges.*—Results indicated that there were at least two patterns of colonization among these five ecologically similar North American thrush species. Even though there were two overall patterns of divergence, I found that there may have been as many as five significantly different divergence events among these five species. It is likely that multiple factors, from local ecology and competition to regional climatic and glacial histories, played a role in determining the current ranges of these five North

American thrushes. I concluded that despite their ecological and distributional similarities, these five thrush species colonized North America in different ways, resulting in individual, species-level differences and two broad continental patterns.