

# Mathematical Model of Power Supply System for Remotely Operated Underwater Vehicle with DC Power Transmission Line and Load Voltage Feedback

Vadim Chekh

Department of Static and Frequency Converters,  
Research Institute of Automation and Electromechanics of Tomsk State University of Control Systems and Radioelectronics,  
Tomsk, Russia  
chekh1993@gmail.com

Danil Lyapunov

Reliability Sector,  
Research Institute of Automation and Electromechanics of Tomsk State University of Control Systems and Radioelectronics,  
Division for Power and Electrical Engineering,  
National Research Tomsk Polytechnic University  
Tomsk, Russia  
lyapunov@tpu.ru

Alexandra Pravikova

Reliability Sector,  
Research Institute of Automation and Electromechanics of Tomsk State University of Control Systems and Radioelectronics,  
Tomsk, Russia  
bezruchenko@niiiaem.tomsk.ru

**Abstract**—The paper deals with a mathematical model of the closed loop power supply system for a remotely operated underwater vehicle with a DC transmission line via a rope-cable and the load voltage feedback. The state-space method is used to develop the mathematical model. Using differential equations in the form of Cauchy alleviates significantly the mathematical description. The results for both simulation and mathematical models of the closed loop system are compared, thus, confirming the adequacy of mathematical description and prospects for further application in the design of a versatile tool for calculating and adjusting the parameters of the control system for the power supply system under study.

**Keywords**—mathematical model, power supply system, remotely operated underwater vehicle, DC power transmission line, load voltage feedback, PI controller

## I. INTRODUCTION

Currently, the use of remotely operated underwater vehicles (ROV) contributes significantly to the development of the oil and gas exploration and production industry in the shelf zones. Moreover, carrying out various underwater works in the seas, oceans and inland waters such as hydrographic and biological researches is an up-to-date demand. Likewise, providing rescue and search operations on sunken objects is a fruitful topic for underwater engineers and scientists. The ROV performance is largely determined by the power supply system (PSS).

According to the review of PSS versions for ROV of a research type [1], the transfer of DC energy over a cable-cable results in a reduction of the weight and size of the underwater part. That is due to the absence of a transformer and voltage converters within the subsea equipment.

The open-loop model of the PSS is considered in [2]. We will use this model to develop a closed-loop model of the PSS to ensure the stable load voltage within  $\pm 10\%$  around its nominal value, and to provide appropriate dynamic performance of the system.

The purpose of the present paper is to develop a mathematical model of PSS for ROV with DC power transmission line over a rope-cable and a load voltage feedback.

## II. BLOCK DIAGRAM OF POWER SUPPLY SYSTEM

The adopted block diagram of the PSS for ROV is portrayed in Fig. 1.

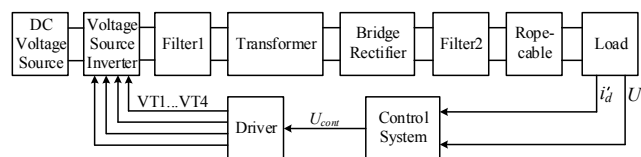

Fig. 1. Block diagram of the closed-loop power supply system.

Accepted designations:  $i_d'$  and  $U_d'$  are the reduced to the primary winding of the transformer load current and voltage, accordingly;  $U_{cont}$  is the output signal of the voltage controller; VT1...VT4 are control signals to drive the gates of the VSI transistors.

The diagram a DC voltage source connected to a voltage source inverter (VSI) with an output filter (Filter1). The output voltage of the filter is applied to the primary winding of the step-up transformer. The secondary winding of the transformer is linked to a single-phase bridge rectifier with its output filter (Filter2), providing the high voltage applied to the load via a rope-cable.

The basic principles of each PSS block operation are considered in detail in [3].

To enable the feedback we need to provide a set of equations for the power part of the PSS depicted in Fig. 2.

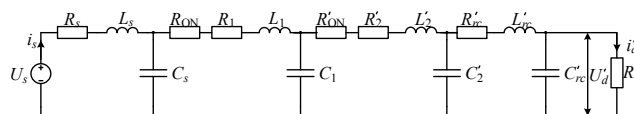

Fig. 2. Equivalent electric circuit of the power supply system.

Accepted designations:  $U_s$  and  $i_s$  are DC source voltage and current, accordingly;  $R_s$ ,  $L_s$ , and  $C_s$  are the resistance, inductance and capacitance of the DC source circuit, accordingly;  $R_{ON}$  and  $R'_{ON}$  are the equivalent on-state resistance of the VSI and the bridge rectifier, accordingly;  $R_1$ ,  $L_1$  and  $C_1$  are

the resistance, inductance and capacitance of the VSI output filter, accordingly;  $R_2'$ ,  $L_2'$  and  $C_2'$  are the resistance, inductance and capacitance of the rectifier output filter, accordingly;  $R_{rc}$ ,  $L_{rc}$  and  $C_{rc}$  are the resistance, inductance and capacitance of the rope-cable, accordingly;  $R_d'$  is the load resistance; the prime mark related to the parameters and values reduced to the primary winding of the transformer.

### III. MATHEMATICAL DESCRIPTION OF THE POWER SUPPLY

A set differential equation for the input circuit of the voltage source inverter (Fig. 2) can be written in the following form:

$$\begin{aligned} \frac{dU_{C_s}(t)}{dt} &= \frac{1}{C_s} \cdot (i_s(t) - i_{in}(t)), \\ \frac{di_s(t)}{dt} &= \frac{1}{L_s} \cdot (E - R_s \cdot i_s(t) - U_{C_s}(t)), \end{aligned} \quad (1)$$

where  $U_{C_s}(t)$  is the voltage on the input circuit capacitor  $C_s$ ,  $i_s(t)$  is the current of the voltage source. The VSI input current  $i_{in}(t)$  is defined by the expression:

$$i_{in}(t) = K_m(\xi) \cdot i_{tr1}(t), \quad (2)$$

where  $i_{tr1}(t)$  is the primary current of the transformer,  $K_m(\xi)$  is the switching function for the VSI, the difference function  $\xi$  is defined by the difference between the reference signal  $U_{ref}(t)$  and the sawtooth time-base voltage  $U_{st}(t)$ :

$$\xi = U_{ref}(t) - U_{st}(t). \quad (3)$$

The output VSI voltage represents the primary voltage of the transformer  $U_{tr1}(t)$  and is described by the following relationship:

$$U_{tr1}(t) = K_m(\xi) \cdot U_{C_s}(t). \quad (4)$$

Within the framework of this paper we neglect the leakage resistances and inductances of the transformer and represent it as an ideal component with the transformation ratio  $K_{tr}$ .

The input current of the rectifier represents the secondary current of the transformer expressing by the formula:

$$i'_{r2}(t) = (K_{1,3} - K_{2,4}) \cdot i'_2, \quad (5)$$

where  $i'_2$  is the output current of the rectifier reduced to the primary winding,  $K_{1,3}$  and  $K_{2,4}$  are the switching functions of the rectifier.

All the issues concerning the control signal formation in the control system under study are considered in [4].

For the output filter of the rectifier the differential equation are as follows:

$$\begin{aligned} U'_{C_2}(t) &= \frac{K_{tr}^2}{C_2'} \cdot (i'_2(t) - i'_{rc}(t)); \\ i'_2(t) &= \frac{1}{L_2' \cdot K_{tr}^2} \cdot (U'_2(t) - U'_{C_2}(t)), \end{aligned} \quad (6)$$

Where  $U'_2(t)$ ,  $U'_{C_2}(t)$ ,  $i'_2(t)$  and  $i'_{rc}(t)$  are reduced to the primary winding output voltages of the rectifier and its output filter, the output current of the rectifier and the current in the rope-cable, accordingly.

The electrical balance equations for the rope-cable acquire the following form:

$$\begin{aligned} \frac{dU'_d(t)}{dt} &= \frac{K_{tr}^2}{C_{rc}} \cdot (i'_{rc}(t) - i'_d(t)), \\ i'_d(t) &= U'_d(t) / (R_d \cdot K_{tr}^2), \\ \frac{di'_{rc}(t)}{dt} &= \frac{1}{L_{rc} \cdot K_{tr}^2} \cdot (U'_{C_2}(t) - R_{rc} \cdot K_{tr}^2 \cdot i'_{rc}(t) - U'_d(t)), \end{aligned} \quad (7)$$

where  $U'_d(t)$  and  $i'_d(t)$  are reduced to the primary windings load voltage and current, accordingly,  $C_{rc}$  and  $L_{rc}$  are the capacitance and inductance of the rope-cable, accordingly,  $R_d$  is the load resistance.

### IV. SIMULATION OF THE POWER SUPPLY

To simulate the model of the PSS with closed loop structure we used both Matlab Simulink 2013b to create a simulation model and Matlab programming to create a mathematical model. Thus, we confirmed the adequacy of the model under development since both aforementioned variants are completely identical.

Using the Matlab Simulink software for developing the simulation model represents a versatile tool to develop both the power circuit and control system in a single file [6]. Whereas programming in C++ language directly [7] using Matlab C++Builder block gives the opportunity to create a program suitable for the PSS controller.

Listing 1 provides the parameter of the PSS and its PI-controller tuned optimally [8] to ensure 1000 V across the load within the error band <1%.

Listing 1

```
//Circuit parameters
Rs=0.0083; Ls=0.001; Cs=0.005; R2=0.54; L2=0.0015;
C2=0.0006; Rrc=23.334; Lrc=0.017; Crc=0.001; Ktr=0.1217;
Rd=30.638;
//Feedback and controller parameters
k_fbv=0.000355; Kp=301.6; Ki=33478.41;
```

Fig. 3 demonstrates the simulation model in Matlab Simulink obtained using S-Function block *contr*.

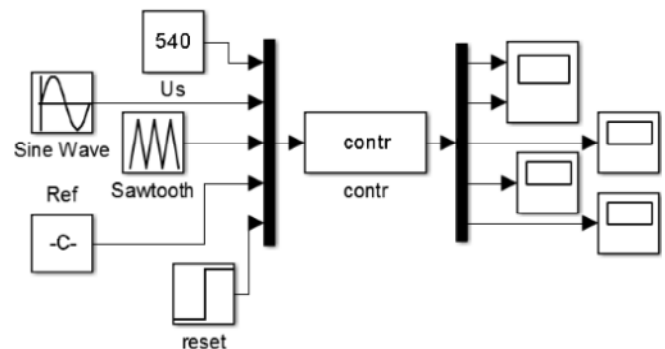

Fig. 3. Simulation model in Matlab Simulink using S-Function.

The software is written in C++ language and solves the set of equations (1)–(7). Here we note that the reference signal, sine wave signal, sawtooth signal, and DC source voltage are obtained directly from Simulink blocks (Fig. 3). This could also be provided within the C++ file *contr.c*. To provide the

appropriate model convergence we used Euler method for solving the differential equations with the step size  $dt=0.000001$ .

We obtained the transient response plot of the output voltage of the PSS applying a step reference at the input  $U_{ref}=0.9$  (Fig. 4).

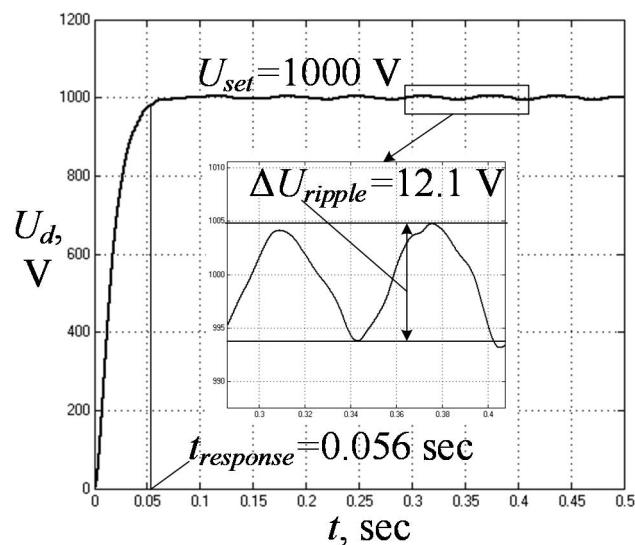

Fig. 4. Transient response plot for the closed-loop power supply system.

Accepted designations:  $U_d$  is the load voltage;  $U_{set}$  is the steady state value of the load voltage;  $\Delta U_{ripple}$  is the ripple amplitude of the load voltage;  $t_{response}$  is the response time.

#### CONCLUSION

Therefore, the mathematical model of PSS for ROV allows investigating both static and dynamic performance of the system under development. Using load voltage feedback along with the controller ensures the output voltage of 1000 V

within the prescribed error band  $\pm 1\%$  as well as the optimal response time. This model will presumably be taken as a basis for the development of an adaptive system that would take into account possible parameter changes during the PSS operation. This will serve as a versatile tool for calculating and adjusting the parameters of the control system. Moreover, the model created will allow investigating all the operating modes of the PSS as well as the effect of the load on the power supply.

#### ACKNOWLEDGMENT

This research was carried out with support of project No. 8.8184.2017/8.9 at Research Institute of Automation and Electromechanics, Tomsk State University of Control Systems and Radioelectronics.

#### REFERENCES

- [1] R. Christ, R. Wernly, The ROV Manual: A User Guide for Observation-Class Remotely Operated Vehicles, Elsevier Ltd, 2007.
- [2] V. Rulevskiy, V. Chekh, V. Shurygin, and A. Pravikova. "Voltage Stabilizer in Power Supply of Underwater Vehicle," IOP Conference Series: Materials Science and Engineering, 327(2), 022018, 2018.
- [3] M. Rashid, Power Electronics Handbook, Elsevier, 2018.
- [4] A. Kobzev, G. Mikhailchenko, A. Andriyanov, and S. Mikhailchenko. Non-linear Dynamics of Semiconductor Converters. Tomsk: TUSUR, 2007.
- [5] R. Dorf, R. Bishop, Modern Control Systems, Pearson Education Limited, 2014.
- [6] S. German-Galkin, Virtual Laboratory of Semiconductor Systems in Matlab Simulink. Moscow, 2013.
- [7] R. Shaffer, Fundamentals of Power Electronics with Matlab. Charles River Media, Boston, Massachusetts, 2007.
- [8] V. Rulevskiy, V. Chekh, V. Bukreev, R. Mescheryakov, "The Power Supply of a Deep-sea Vehicle with HVDC Transmission by Strength-power Communications Cable," Bulletin of the South Federal University, Technical Sciences, V. 1 (195), 2018, pp. 155–167.