

Singapore Management University

Institutional Knowledge at Singapore Management University

Research Collection School of Social Sciences

School of Social Sciences

1-2020

Mitigation of a prospective association between early language delay at toddlerhood and ADHD among bilingual preschoolers: Evidence from the GUSTO Cohort

Shaun K. Y. GOH

National University of Singapore

Hwajin YANG

Singapore Management University, hjyang@smu.edu.sg

Stella TSOTSI

Agency for Science and Technology Research

Anqi QIU

National University of Singapore

Yap-Seng CHONG

Agency for Science and Technology Research

Follow this and additional works at: https://ink.library.smu.edu.sg/soss_research

See next page for additional authors



Part of the [Applied Behavior Analysis Commons](#), and the [Child Psychology Commons](#)

Citation

GOH, Shaun K. Y., YANG, Hwajin, TSOTSI, Stella, QIU, Anqi, CHONG, Yap-Seng, TAN, Kok Hian, SHEK, Lynette, Broekman, Birit F. P., & Rifkin-Graboi, Anne.(2020). Mitigation of a prospective association between early language delay at toddlerhood and ADHD among bilingual preschoolers: Evidence from the GUSTO Cohort. *Journal of Abnormal Child Psychology*, 48, 511-523.

Available at: https://ink.library.smu.edu.sg/soss_research/3104

This Journal Article is brought to you for free and open access by the School of Social Sciences at Institutional Knowledge at Singapore Management University. It has been accepted for inclusion in Research Collection School of Social Sciences by an authorized administrator of Institutional Knowledge at Singapore Management University. For more information, please email library@smu.edu.sg.

Author

Shaun K. Y. GOH, Hwajin YANG, Stella TSOTSI, Anqi QIU, Yap-Seng CHONG, Kok Hian TAN, Lynette SHEK, Birit F. P. Broekman, and Anne Rifkin-Graboi

Mitigation of a Prospective Association Between Early Language Delay at Toddlerhood and ADHD Among Bilingual Preschoolers: Evidence from the GUSTO Cohort

Shaun K. Y. Goh¹, Hwajin Yang², Stella Tsotsi³, Anqi Qiu^{1,3}, Yap-Seng Chong^{3,4}, Kok Hian Tan⁵, Lynette Shek Pei-Chi^{3,6}, Birit F. P. Broekman³ & Anne Rifkin-Graboi³

Published in Journal of Abnormal Child Psychology, 2020, volume 48, pp. 511–523

<https://doi.org/10.1007/s10802-019-00607-5>

Creative Commons Attribution-Noncommercial-No Derivative Works 4.0 License

Abstract

There is accumulating evidence of a prospective relation between early language problems and ADHD, a disorder associated with deficits in executive functioning. However, little is known regarding this link among bilingual children. Here, we investigate whether (i) the prediction from language to ADHD may be lower among bilinguals, and (ii) explore if this moderation can be explained by differential executive functioning ability. Utilising a prospective sample of 408 South-East Asian toddlers, bilingual exposure as a moderator of the link between language delay at 24 months to ADHD intermediate diagnosis at 54 months was first examined with an interaction model. Next, structural equation mediated moderation models examined if the proposed moderation could be explained by executive function measures of Snack Delay and Dimensional Change Card Sort (DCCS) task, when children were 41 months. Results indicate that higher levels of bilingual exposure moderated the prospective risk of language delay to ADHD diagnosis (Predominantly single-language exposed OR = 6.37; $p = .011$; Predominantly dual-language exposed OR = 0.30, $p = .156$). Thus, language delay associated with ADHD among toddlers predominantly exposed to one but not two languages. However, this could not be explained by differential executive functioning, as this moderation was not mediated by performance on Snack Delay or DCCS. Unexpectedly, bilingual exposure associated with ADHD among toddlers of typical language development. Possible explanations, including variation in the degree of social stigma and persistence of language delay between bilingual and monolingual children, and bilingualism as an additional cognitive load for ADHD, are discussed.

Keywords: Language delay, Bilingualism, Attention deficit hyperactivity disorder, Executive functioning

Author Note: Shaun K.Y.Goh, Stella Tsotsi, and Anne Rifkin-Graboi are now at the Centre for Research in Child Development, Office of Educational Research, National Institute of Education, Nanyang Technological University

Anne Rifkin-Graboi anne.rifkin@nie.edu.sg

1 Department of Biomedical Engineering, National University of Singapore, 21 Lower Kent Ridge Rd, 119077 Singapore, Singapore

2 School of Social Sciences, Singapore Management University, Victoria St, 188065 Singapore, Singapore

3 Singapore Institute for Clinical Sciences, Agency for Science and Technology Research (A*STAR), Brenner Centre for Molecular Medicine, 30 Medical Drive, Singapore, Singapore

4 Department of Obstetrics & Gynaecology, Yong Loo Lin School of Medicine, National University of Singapore, National University Health System, 21 Lower Kent Ridge Rd, Singapore, Singapore

5 KK Women's and Children's Hospital, 100 Bukit Timah Rd, Singapore, Singapore

6 Department of Paediatrics, Yong Loo Lin School of Medicine, National University of Singapore, National University Health System, 21 Lower Kent Ridge Rd, Singapore, Singapore

There is accumulating evidence that a marked difficulty in expressive and/or receptive language ability in the absence of an obvious cause such as a sensory, intellectual or cognitive impairment increases the risk and severity of later ADHD. For example, a recent meta-analysis (Yew and O’Kearney 2013) reported that the presence of a language impairment was prospectively associated with increased risk and severity of ADHD problems in childhood and early adolescence. Indeed, a recent longitudinal study (Yew and O’Kearney 2017) reported that 439 children from the age of four identified with early language difficulties, in the absence of hearing impairment, intellectual disability and autism spectrum disorder, showed persistently elevated trajectories of inattention and hyperactivity till the age of twelve. Similar, but less specific associations, have also been observed in children of younger ages. For example, language-based interventions, administered with children between 24 and 42 months, have been found effective in reducing externalizing behaviors (e.g. Curtis et al. 2019). Such work, then, further suggests that language problems may be a risk for attentional difficulties, in young children, however as externalizing behaviors encompass both attentional and aggressive problems, additional work focusing on young children is needed.

Moreover, little is known regarding the nature of the link between language and ADHD among bilinguals, despite estimates of a greater number of bilinguals than monolinguals across the world’s populations (Grosjean 2015). Bilinguals, like their monolingual counterparts, are afflicted with language problems, inattention and hyperactivity (Toppelberg et al. 2002). We aim to address these gaps by examining the relation between language delay and attentional problems across both bilingual and monolingual toddlers. We also explore whether any differences are due to variation in executive functioning performance as past research indicates links between executive functioning and bilingualism (Bialystok 2015; Green and Abutalebi 2013; but also see Paap et al. 2015) as well as between executive functioning and ADHD (Pauli-Pott and Becker 2011; Willcutt et al. 2005). In fact, conceptual models (e.g. Adaptive Control Hypothesis; Green and Abutalebi 2013) posit that bilingual environments foster executive functioning. Because comparatively low executive functioning may play a role in ADHD (Barkley 1997), any such enhancement of executive functioning may be likely to improve attentional outcomes.

We are aware of only one group (Toppelberg et al. 2002, 2006) that has published work investigating the relation of language and attentional problems among bilinguals. Latino children and adolescents from an outpatient clinic, exposed to both English and Spanish, were administered a comprehensive battery of expressive and receptive language abilities in both the English and Spanish languages. Higher language proficiency was moderately correlated with lower severity of attentional problems. These relations are unlikely to have been due to ASD, hearing impairment, or non-verbal IQ, as these potential confounds were taken into account either within the exclusion criteria or via the selection of covariates. Despite the importance of this research, more studies are needed to understand the developmental process which underlying the link during early childhood.

Links Between Language Proficiency, Executive Function and ADHD

Influential proposals have conceptualized executive function (EF) as a unitary top-down system which regulates visual and phonological components of memory (central executive system; Baddeley 2003), a fractionable system with behavioural inhibition as a ‘core’ component (Barkley 1997), or as involving multiple processes of inhibition, interference control, working memory and cognitive flexibility (Diamond 2014). Still, there is consensus that EF involves components of shifting, updating and inhibition (Miyake et al. 2000).

Language plays an important role in directing behavior and goals, as well as in the understanding and expression of emotions necessary for regulation. For example, oral language in the form of self-directed utterances is proposed (Barkley 1997; Petersen et al. 2013) to allow for the description and analysis of external stimuli, which ultimately leads to the eventual formulation of goals and plans in-order to guide behavior. Not surprisingly then, a recent meta-analysis (Pauls and Archibald 2016) conducted across 34

studies found that children with language impairment scored lower than typical language controls on multiple EF measures. Compared to typical language controls, language impaired children were reported to have lower scores of -0.27 SD for set shifting tasks and -0.54 SD for inhibitory tasks. Findings did not differ between verbally and non-verbally based inhibitory tasks, arguing against the possibility that the association between language impairment and executive functioning was a spurious correlation merely due to the language demands of the tasks.

Language has also been found to contribute to executive functioning among very young children. Kuhn et al. (2016) in a large multi-site prospective study reported that a composite of expressive language and social communication at either age two or three significantly predicted a latent factor of EF tasks of shifting, updating and inhibition at age four. Also reported are findings of the contribution of language even in preverbal stages, as shown by a significant path of parental report of toddler use of communicative gestures, to language and, finally to EF at ages 2, 3 and 4 respectively. Together, these studies highlight the close link between language ability and EF during infancy and early childhood.

Likewise, much work suggests that those with ADHD face deficits across multiple domains of executive function. Although behavioural inhibition, or the ability to suppress a behavioral response, is classically thought to be the 'core' ADHD deficit (Barkley 1997), a large meta-analysis (Willcutt et al. 2005; $d = .51$ to $.69$) of 83 studies among 6700 adults found medium-sized effects of ADHD across 12 tasks of executive functioning beyond just inhibition, such as shifting and updating.

Similar to what is observed in adults, difficulties in multiple aspects of executive functioning have been found related to attentional problems in children. Pauli-Pott and Becker (2011) conducted a meta-analysis of studies which related various aspects of executive function to ADHD among preschoolers aged three to six. Small to medium sized effects of $r = .22$ to $.38$ were found across domains of shifting and inhibition to ADHD. For instance, in one of the larger studies considered by the aforementioned meta-analysis, Sonuga-Barke et al. (2003) reported that ADHD symptoms were predicted by two factors of executive function. Unsurprisingly, the first was comprised of 'standard' measures of EF such as shifting and updating (e.g. Miyake et al. 2000). Still, a second factor that also predicted ADHD was comprised of two measures of inhibition in emotionally salient contexts, one of which was a 'snack delay' measure of the extent to which children were able to wait for a signal to retrieve a cookie placed in a transparent cup. Similarly, in a study of 926 preschoolers (Willoughby et al. 2011), Snack Delay performance was not only correlated with ADHD symptoms, but predicted ADHD symptoms over and above a latent factor of other measures of EF. Recent empirical work among older children is consistent with the few preschool studies ($n = 3$; Pauli-Pott and Becker 2011) linking shifting with ADHD. Kofler et al. (2018) found that children aged 8 to 13 who met diagnostic criteria for ADHD showed moderately poorer performance on set shifting tasks such as number-colour. Children were presented pairs of numbers and clicked on the larger or smaller number depending on the colour of the numbers. Overall, 38% of this sample performed at the level of impairment on executive functioning tasks involving rule/set shifting while 89% did so on at least one domain of executive functioning.

Despite these documented associations between language ability and EF, and EF and attentional problems, to our knowledge only one study has simultaneously investigated a pathway between these links. Petersen et al. (2015) reported that the expressive and receptive language abilities of 159 2 ½ year olds predicted attention problems one year later. Crucially, this relationship was significantly mediated by performance on tasks requiring set shifting or the inhibition of a highly-learned rule (e.g., green is the color of grass; white is the color of snow) in- order to respond using a conflicting rule (e.g., select white when you see grass; select green).

These findings report linkages between low language proficiency, executive function, and attentional problems. Low executive function is a known risk factor for ADHD, and studies of children with language

impairment indicate that low language ability also associates with both executive function and ADHD. These findings are consistent with the idea that there are multiple risk factors (e.g., low cognition, male sex, and complications in labour (Russell et al. 2014; Silva et al. 2014)) for ADHD in toddlerhood. However, little is known about potentially protective factors. Below, we consider whether bilingualism may serve as one such protective factor.

Low Language Proficiency and the ‘Bilingual Advantage’

Executive function abilities may also be influenced by bilingualism. Bilinguals are proposed to inhibit distracting mental information from one language while selecting information from the other language (Bialystok 2015; Bialystok et al. 2012), allowing for extensive practice of executive functions of cognitive inhibition, set shifting, and/or the management of “conflict”. In support of this argument are reports of bilingual children outperforming monolingual children on switch tasks. For example, Carlson and Meltzoff (2008) reported better performance among children exposed to two languages from birth on a composite of executive functioning measures which included the Dimensional Change Card Sort Task (DCCS; Zelazo 2006) in a sample of 50 Spanish-English monolingual and bilingual 6 year old children. In the DCCS, children are sequentially shown bivalent cards. The cards differ along two dimensions (i.e. colour and shape). Children may be shown cards with a picture of either “Red-Boat” or “Blue-Car.” Initially, children are asked to match cards to one of two different target cards (e.g., “Red-Car” or “Blue-Boat”), according to one dimension. They are then asked to match test to target cards according to the other dimension. Children presumably suppress the first sorting rule, as it is impossible to sort by both rules at the same time without making mistakes (e.g. when sorting by color, a “red-boat” should be matched to a “Red-Car”; when sorting by shape, the “red-boat” should be matched to the “Blue-Boat”). Authors therefore similarly attribute the “bilingual advantage” in studies of rule suppression and selection to the increased experience bilinguals have in switching between languages in every-day life (e.g. (Bialystok and Martin 2004; Carlson and Meltzoff 2008).

It follows, then, that bilingual children with low language proficiency could be expected to have fewer opportunities than do bilingual children with high language proficiency, to practice rule suppression and selection in every-day language usage. As such, bilingually exposed children with language delay might be expected to have less of an “bilingual advantage in executive function” compared to bilingual children of average or higher language proficiency. Indeed, bilingual children with language impairment, who scored lower than the 10th percentile on standardized tests in both languages ($n = 15$), performed poorer on an executive functioning task assessing the ability to attend to central rather than peripheral and conflicting stimuli (i.e., the Flanker), as compared to bilingual children with typical language development matched for socio-economic status and age (Engel de Abreu et al. 2014). Likewise, Iluz-Cohen and Walters (2012) reported poorer performance on measures of cognitive inhibition and shifting (i.e. embedded figures, card sort) for English-Hebrew bilingual preschoolers who scored within cut-offs in clinical ranges on language assessments in both languages.

Nonetheless, bilingual children with low language proficiency will still have, by definition, greater exposure to a second language relative to monolingual low language proficiency counterparts. Thus, they may still be expected to possess some advantage in executive functioning as compared to their monolingual peers. Recent work finds that ‘exposure’ alone may influence executive functioning, among toddlers with little or no practice in the usage of language. Poulin-Dubois et al. (2011) classified 63 two-year old English-French infants as either bilingual or monolingual based on the percentage of exposure to language(s). Similar to findings among older children, bilingual infants were more accurate on the shape-stroop task, which requires the suppression of highly-learned information, though significant differences were not observed on all measures testing cognitive inhibition or other aspects of executive functioning. Moreover, seven month old infants (Kovács and Mehler 2009) who were exposed to two languages on a daily basis were found to be more accurate on a switch task. Specifically, during pre-switch, infants were repeatedly exposed to audio cues followed by a visual stimuli that always appeared on the same side of the screen. During post-switch, the visual stimuli appeared on the opposite side of the screen as compared to pre-switch. Bilingual toddlers were

more accurate in the direction of their anticipatory looks during post-switch than monolingual toddlers ($n = 20$ respectively). This finding was replicated across two new samples of seven month old infants with variations to the paradigm such as the use of visual as opposed to auditory cues.

Current Study

In sum, the current work addresses gaps in the understanding of ADHD, namely the association of low language proficiency during toddlerhood and ADHD during preschool, and the role that monolingual/bilingual language exposure plays. This study leverages on the wide variation present in bilingualism in Singapore, a city-state in South East Asia where the majority of its residents identify as bilingual (Singapore Department of Statistics 2011). English is the language of instruction in schools and the language used by large bodies such as the Government. Three languages, i.e., Mandarin, Melayu Bahasa, and Tamil, are recognized as official languages. At school age, as primarily determined by their ethnicity, children are required to take one of these three mother-tongue languages.

As it is possible that bilingual advantages in executive functioning are present from a preverbal age, we hypothesise that the prospective risk of low language proficiency to ADHD is lower among bilinguals. As the exact mechanisms remain unclear, we examine if bilingual exposure (i) exerts protection equally across varying levels of a toddler's proficiency in language (i.e. as a main effect) as suggested by findings among toddlers; or (ii) unequally, where protection is reduced for toddlers with low language proficiency (i.e. a moderation effect of language delay x bilingual exposure) who may not switch between languages as frequently as do their higher proficient bilingual peers. At this age, low proficiency is more commonly referred to as language delay. We also explore whether this pattern of moderation can be explained by differential performance on multiple facets of executive functioning. To further increase the robustness of this study, we utilised direct laboratory based assessments such as the DCCS and Snack Delay tasks for executive functioning, and applied stringent cut-offs. For example, children were required to meet both symptom criteria and functional impairment to meet a positive diagnosis indicative of ADHD. Moreover, given associations between ADHD, behavioural and language problems, oppositional defiance disorder diagnosis was included as an additional covariate.

Methods

Participants

Mother-toddler dyads were part of the longitudinal study 'Growing up in Singapore Towards Healthy Outcomes' (GUSTO; Soh et al. 2014) designed to investigate multiple aspects of Southeast Asian children's physical, emotional, and cognitive well-being. Our analyses utilise data collected from children at the 24, 42 and 54 month time points and parental reports collected throughout the ongoing study. To ensure adequate statistical power across ethnicities, the GUSTO study from which this sub-sample is derived from oversampled for ethnic minorities. Census data from Singapore, where this study was conducted suggests similar rates of bilingualism across ethnicities (Singapore Department of Statistics 2011). Nonetheless, there may be variation in study variables by ethnicity, and is thus included as a covariate in all models.

Of the 514 toddlers administered the Bayley Scales of Infant and Toddler Development (BSID-III; Bayley 2006), 21 did not complete (e.g. due to fussiness). See the online supplement for a flowchart regarding the application of exclusion criteria. In brief, toddlers ($n = 52$) with conditions that may impinge upon classification of language delay were excluded. This included non-mutually exclusive criteria of (i) low cognitive raw scores of $>2SD$ below sample means on either BSID-III cognitive scale or on Kaufman Brief Intelligence Test (Kaufman and Kaufman 2004) non-verbal matrices administered at 2 and 4.5 years respectively ($n = 29$); (ii) children reported to have engaged health professionals over Autism Spectrum Disorder (ASD; $n = 3$) and a further subset who scored above cut-off on a screen of ASD ($n = 12$; Quantitative Checklist for Autism in Toddlers; Allison et al. 2008) (iii) children reported by parents to have relevant

medical concerns (Epilepsy = 7; Traumatic Brain Injury = 1; Hearing Difficulties = 2). Further exclusions due to borderline language status and trilingualism, explained in ‘measures’, resulted in 408 toddlers for inclusion in the current work. Approval from National Health Care Group Domain Specific Review Board (D/09/021 and 2014/00414) and SingHealth Centralized Institutional Review Board (2009/280/D) was obtained, with informed written consent from each participant.

Measures

Language Delay

Toddlers were classified with regard to language delay based on their expressive and receptive BSID-III language subscale factor scores. The administration, adaptations for use across this multilingual sample, and factor score model free of possibly biased items are reported elsewhere (Goh et al. 2017). In brief, the BSID-III was administered at a 24-month-old toddler home visit. Six examiners who spoke two or more study relevant languages were trained by the head psychologist from Singapore’s KK Hospital’s pediatric unit on the administering and scoring of the BSID-III. Items were adapted to Chinese, Bahasa Melayu, and Tamil equivalents. In accordance with the administrative procedure at KK Hospital, examiners first determined the child’s dominant language by (i) observing the child’s language use via period of unstructured interaction and (ii) asking parents. Examiners had the option to readminister items in the child’s non-dominant language if they judged the child might not have understood the item in his/her dominant language. Examiners also accepted equivalent responses in a dominant language, a mix, or entirely in a nondominant language (e.g. give ball, bagi ball and bagi bola). Examiners estimated the % of language each BSID-III was administered in. Overall, they estimated that 48.5% of the BSID-IIIs were administered fully in one language (66.2% English, 24.7% Mandarin, 6.1% Malay, 3.0% Tamil). In contrast, 51.5% of the BSID-III’s were substantially administered in more than one language. In 58.1% of these 51.5% cases, the primary language (>50% of test) was in English, in 13.8% cases it was Mandarin, in 21.0% it was Bahasa Melayu, and in 6.7% cases it was Tamil.

BSID-III language items were subjected to a further psychometric evaluation (Differential Item Functioning; Goh et al. 2017) with those found to show bias removed. Bias was shown by 5 items where over and above latent language ability, the extent of exposure to either English or Bilingual backgrounds predicted performance on receptive items 18, 19 and 22 and expressive items 24 and 26. After removal of these items, language subscales now uniformly passed fit indices and good reliability in the range to detect language delay ($\alpha > 0.8$ when standardized language scores = -2.6 to -0.8 SD). Crucially, language scores were not associated with bilingual or non-English exposure. Similar to previous classifications of bilingual language proficiencies (Collins et al. 2014), toddlers who scored < -1.25 SD on expressive or receptive subscales were classified as language delayed while those who scored > -1 SD on expressive and receptive subscales were classified as having typical language development. Toddlers ($n = 24$) who fell were below -1 SD but were still above -1.25 SD could not be clearly classified as showing low language proficiency. As they were insufficient to provide statistical power as a subgroup on their own, these children were excluded from subsequent analysis.

Bilingual exposure

This is scored as the exposure in the language heard less frequently by the child (i) Caregivers were asked “Consider your baby’s whole life, up till the time that he/she was 24 months. When you, your spouse and everybody else in your baby’s life talked to him/her, what percentage of each language was spoken to him/her?” (ii) The input of caregivers in each language was thus reported (e.g. 51% English, 49% Mandarin, all scores sum to 100%). (iii) The less frequently heard language was utilised as a score of bilingual exposure. For example, a monolingual with 100% Language 1 and 0% Language 2 would receive the minimum score of 0. A balanced bilingual with 50% Language 1 and 50% Language 2 would receive the maximum score of 50. (iv) Toddlers ($n = 10$) with $>10\%$ exposure on three or more languages were considered as trilinguals and excluded. As multi-lingualism may not show the same relations to executive functioning as does bilingualism

(Brito et al. 2014), such toddlers present a possible source of unwanted variability in this study on possible effects of bilingualism.

Executive Functioning

The DCCS (Zelazo 2006) and Snack delay (Kochanska et al. 1996) tasks were administered in the children's preferred language as part of a battery of laboratory tasks by bilingual examiners when the GUSTO toddlers were 42 months of age. For the DCCS, examiners first explained and demonstrated how to sort two bivalent colour-food cards into two trays according to the color rule. Next, six pre-switch trials were conducted, where toddlers were verbally reminded of the colour rule and card label before each trial (e.g. This is the colour game. This is a red one. Where does it go?). Similarly, post-switch consisted of six trials. Toddlers were told the new 'food' rule and how to sort according to it, at the start of the block of trials (i.e. not the 'colour' game but now we play the 'food game', the cake ones go here). Children ($n = 21$) with $<75\%$ accuracy on pre-switch trials were dropped due to comprehension concerns. Consistent with the protocol (Zelazo 2006) of this task, those who scored $>75\%$ correct on post-switch trials were grouped as 'Pass', while all other toddlers were grouped as 'Fail'.

In Snack delay, the child was instructed to place both hands flat on a mat and wait for the experimenter to ring a bell before retrieving a snack (colorful chocolates, or small snack foods in case of allergy or if mother objected to sugar) placed under a transparent plastic cup positioned 5 cm away. Two practice trials were conducted followed by four test trials with delay intervals of 10s, 20s, 30, and 15 s. The bell was only pressed when the delay interval for that trial had passed. This task was video-recorded and scored by one of three independent raters according to the task author's protocol (Kochanska et al. 1996). The ability of the child to resist reaching out for the bell or the stimulus was scored from 1 to 7 and up to 2 additional points could be given if the child had maintained both hands on the mat throughout the task. The final score was averaged across all four trials with intra-class correlations of .96 across 14% of the video tapes.

ADHD

The Diagnostic Interview Schedule for Young Children (DISC-YC; Fisher and Lucas 2006), a computer-assisted interview, was administered during a 54-month old centre visit. The DISC-YC is a highly structured clinical interview keyed to DSM-IV and ICD-10 and is meant for use among caregivers of children aged 3 to 8. Though verified official translations of the DISC-YC in Mandarin, Bahasa Melayu and Tamil would have been ideal, they do not exist, and were instead forward and backward translated locally for the GUSTO cohort. The DISC-YC was administered predominantly in English (82.7%) or Mandarin (14.2%), by bilingual university graduates trained to do so in the caregiver's preferred language. A test-retest correlation of .67 has been previously reported (Lavigne et al. 2009) for this ADHD subscale. On a similar DISC-IV ADHD subscale administered to older Chinese children, a good inter-rater kappa reliability of .81 was reported (Ho et al. 2005). 'ADHD diagnosis' was coded for children who met diagnostic criteria and were positively endorsed on at least one of six impairment questions. 'No ADHD diagnosis' was coded for children who did not meet ADHD symptom criteria, or met ADHD symptom criteria but showed no impairment. These computer-generated classifications which are indicative of ADHD were further verified by a Psychiatrist, who, in keeping with DSM diagnostic procedures and criteria, reviewed each case considering the number, duration, and severity of symptoms present across situations before assigning the ADHD category.

Socio-economic Status

Mother's highest level of education ("1" = Primary, "2" = Secondary, "3" = Tertiary, "4" = University, "5" = Post-graduate) was recorded at 26 weeks pregnancy and utilised as a continuous measure of socio-economic status (SES). Maternal education is a known predictor of language and commonly utilised as an indicator of socio-economic status in studies of ADHD. Russell et al. (2016) in a recent meta-analysis between the association of ADHD and measures of SES reported overlapping 95% Cis of the estimates of

maternal education, versus other single and other multi-variable measures of SES. Maternal education is thus utilised here to index SES.

Statistical Analysis

Missing data was handled through multiple imputation, a method which is more robust than complete case analysis, which requires additional assumptions beyond data to be missing at random to be unbiased (MAR; Graham 2009). Auxiliary variables which either were related to the outcome or possible mechanisms of missingness were included, to better meet MAR assumptions. Twenty multiply imputed datasets were generated in SPSS v25 utilising fully conditional specification, which allows for linear regression to be used for continuous variables and logistic regression for categorical variables. See online supplement S2 for further details.

First, a two-way moderation model with mean-centered language delay and bilingual exposure as predictors was specified in SPSS v25. Logistic regression was utilised to simultaneously investigate main and interactive effects of bilingualism and language delay on the categorical outcome of ADHD diagnosis. This model was then adjusted to include possible confounds of gender, DISC-YC diagnosis of oppositional defiance disorder, socio-economic status, cognitive ability, age and ethnicity as covariates. The least biased ‘just another variable’ approach was utilised (Seaman et al. 2012) where the interaction term was calculated prior to multiple imputation in the moderation model. Significant interactions which survived adjustment were subsequently decomposed utilising syntax developed for simple slope decompositions with multiply imputed data (Enders et al. 2014).

A mediated moderation model (Preacher et al. 2007) builds on the aforementioned moderation model by including measures of executive functioning in additional mediation paths (Fig. 2). DCCS and Snack delay were included as mediators in paths leading from the main and interaction terms of language delay X bilingual exposure to ADHD. This model was run with Mplus version 7.4. As the mediated effect was anticipated to be non-normal, bootstrap with 1000 redraws via the maximum likelihood estimator was utilised. Paths with categorical variables of the DCCS and ADHD diagnosis were estimated through logit link functions. No fit indices are available as numerical integration is required to estimate this model (Muthén and Muthén 2017). The ‘just another variable’ approach was not possible for the statistical test of mediated moderation model as the model indirect MOD command requires the interaction to be equivalent to the product term. Thus, an ‘impute then transform’ approach was utilised (Seaman et al. 2012).

Results

Table 1 multiply imputed results indicate that language delayed toddlers were on average slightly younger, had a larger percentage of boys, from lower SES families, had lower cognitive scores, and poorer performance on snack delay. These differences are consistent with demographic and cognitive findings of children with language difficulties (St Clair et al. 2019; Yew and O’Kearney 2017). With the exception of Snack Delay which we test as a mediator, significant variables are included as covariates to adjust for their possible confounding influence. Zero-order correlations are reported in online supplement S1.

Table 1 Descriptives for language delayed and typical language toddlers based on multiply imputed data

	Language delay (LD; <i>n</i> = 74)		Typical language (TLD; <i>n</i> = 334)		Test statistic	<i>p</i> value
	Mean/%	SE/Count	Mean/%	SE/Count		
<i>Demographics</i>						
Age (days)	730.16	2.01	736.23	1.02	-6.07 ^b	.010
Gender(Boys)	67.6%	50	49.1%	164	-0.77 ^c	.005
Ethnicity ^a (Chinese, Malay, Indian)	56.8%;29.7%; 13.5%	42;22;10	57.1%; 24.6%; 17.3%	191;82;58	1.17 ^d	.558
SES	2.80	0.10	3.18	0.05	-0.38 ^b	.001
<i>Study Variables</i>						
Bilingual exposure scores	28.02	2.59	25.01	0.92	3.00 ^b	.248
Cognitive Scores	95.41	0.88	106.02	0.66	-10.61 ^b	.000
ODD intermediate diagnosis	20.9%	15.5	30.5%	101.9	-0.51 ^c	.125
ADHD intermediate diagnosis	18.5%	13.7	17.5%	58.6	0.06 ^c	.861
Passed DCCS	29.2%	21.6	34.9%	116.6	-0.40 ^c	.530
Snack Delay	7.57	0.20	8.04	0.08	-0.47 ^b	.010

^a Based on complete case analysis of *n* = 405 as the multiply imputed version of this variable was dummy coded into 2 variables and thus could not be analysed as a single outcome variable

^b linear regression unstd beta for continuous outcomes

^c logistic regression unstd beta for binary categorical outcomes

^d chi-square for nominal categorical outcome with 2 degrees of freedom

Moderation Models: Do Higher Levels of Exposure to Bilingual Language Environment Mitigate the Association of Language Delay to ADHD

Table 2 presents the main and two-way interactions of language delay and bilingual exposure to ADHD status 2 ½ years later. Language delay x bilingual exposure predicted ADHD in the unadjusted model [OR = 0.92 (0.85, 0.99), *p* = .027]. This continued to hold when adjusted for multiple covariates of gender, SES, ODD diagnosis, ethnicity, age and cognitive scores [OR = 2.24 (1.13, 4.45), *p* = .022]. As there are no agreed upon cut-offs for defining a bilingual or monolingual across studies, we decompose this interaction by utilising conventional -1 SD (10.2%), 0 SD (25.6%) and + 1 SD (40.4%) simple slope values of bilingual exposure. These correspond to toddlers predominantly exposed to a single language (90–10); a moderate exposure to two language (74–26), and predominantly to two language (60–40).

Table 2 Moderation and mediated moderation models of language delay and bilingual exposure on ADHD diagnosis

	Unstandardised Beta (SE)	Odds ratio (95% CI)	p value
<i>Model 1a: Unadjusted moderation (n = 408)</i>			
Language delay status	0.01 (0.39)	1.02 (0.47, 2.19)	.971
Bilingual Exposure	0.00 (0.01)	1.00 (0.98, 1.03)	.758
Language delay status x Bilingual Exposure	-0.09 (0.04)	0.92 (0.85, 0.99)	.027
<i>Model 1b: Adjusted moderation (n = 408)</i>			
Language delay status	0.33 (0.46)	1.39 (0.56, 3.45)	.476
Bilingual Exposure	0.01 (0.01)	1.01 (0.99, 1.04)	.364
Language delay status x Bilingual Exposure	-0.10 (0.04)	0.91 (0.84, 0.98)	.017
Gender	-0.61 (0.34)	0.55 (0.28, 1.07)	.078
Socioeconomic Status	0.27 (0.22)	1.31 (0.86, 2.00)	.209
Ethnicity Dummy Code 1	0.14 (0.45)	1.15 (0.47, 2.80)	.757
Ethnicity Dummy Code 2	-0.87 (0.57)	0.42 (0.14, 1.29)	.130
Age	0.01 (0.01)	1.00 (0.99, 1.02)	.514
Oppositional Defiance Disorder	0.81 (0.35)	2.24 (1.13, 4.45)	.022
Cognitive Scores	0.01 (0.01)	1.01 (0.99, 1.04)	.372
<i>Model 2: Adjusted mediated moderation (n = 408)</i>			
<i>Indirect effect of LDxBE → DCCS → ADHD</i>			
At -1SD Bilingual Exposure	0.00 (0.01) ^a	1.01 ^b	.859
At 0SD Bilingual Exposure	0.00 (0.01) ^a	1.00 ^b	.916
At +1SD Bilingual Exposure	0.00 (0.01) ^a	1.00 ^b	.935
<i>Indirect effect of LDxBE → Snack Delay → ADHD</i>			
At -1SD Bilingual Exposure	0.02 (0.02) ^a	1.09 ^b	.421
At 0SD Bilingual Exposure	0.01 (0.01) ^a	1.07 ^b	.376
At +1SD Bilingual Exposure	0.01 (0.01) ^a	1.05 ^b	.556

^a Estimates and standard errors of total natural indirect effects as reported in MPLUS

^b 95% CIs are not reported as they cannot be calculated with bootstraps in multiple imputation in MPLUS

As shown in Fig. 1, language delay predicted an increased probability of receiving a diagnosis of ADHD only for toddlers predominantly exposed to a single language [OR = 6.37 (1.55, 26.10), $p = .011$]. To further confirm this pattern of results where an association appears to be only found among relatively monolingual but not relatively bilingual toddlers, we further examined the association at scores which correspond to the minimum and maximum of 0% and 50% level of bilingual exposure, where toddlers can be considered ‘de facto monolinguals (0-100)’ and ‘balanced bilinguals (50-50)’. The same pattern of results held, where language delay predicted an increased probability of ADHD only among de facto monolinguals (0–100) [OR = 17.52 (2.12, 144.51), $p = .008$] but not among balanced bilinguals (50–50) [OR = 0.12 (0.01, 1.25), $p = .076$]. See online supplement for plots. Finally, among the typical language group, increasing levels of bilingual exposure associated with a higher probability of ADHD [OR = 1.03 (1.00, 1.06), $p = .047$]; whereas among the language delay group, this relation may be present in the opposite direction as increasing levels of bilingual exposure were marginally associated with lower probabilities of ADHD [OR = 0.93 (0.87, 1.01), $p = .072$].

Fig. 1: Plot of significant language delay x bilingual exposure interaction to probability of ADHD diagnosis adjusted by gender, SES, ethnicity, cognitive scores, age and ODD diagnosis with annotations for p-values of tests of simple slopes. Note : PSL = Predominantly single language exposure; MTL = Moderate two language exposure; PTL = Predominantly two language exposure. a $p = .476$, OR = 1.39 [0.56, 3.45]; b $p = .156$, OR = 0.30 [0.06, 1.59]; c $p = .072$, OR = 0.93 [0.87,1.01].

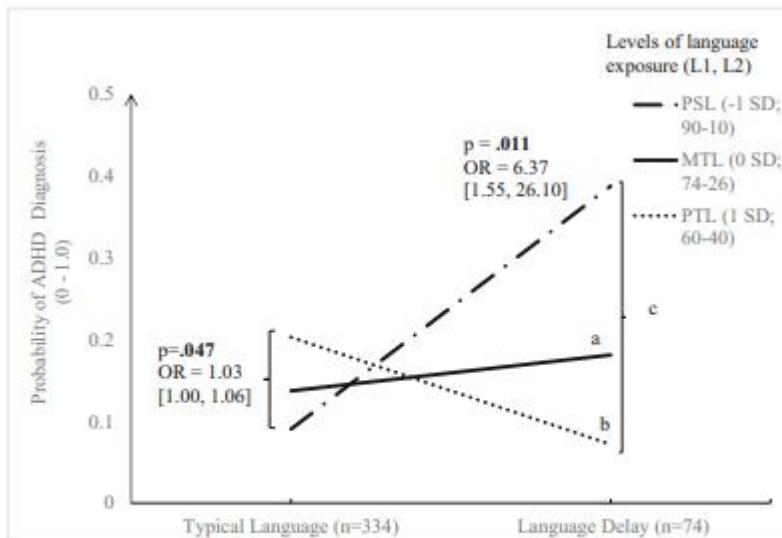

Note : PSL = Predominantly single language exposure; MTL = Moderate two language exposure; PTL = Predominantly two language exposure. ^a $p = .476$, OR = 1.39 [0.56, 3.45]; ^b $p = .156$, OR = 0.30 [0.06, 1.59]; ^c $p = .072$, OR = 0.93 [0.87,1.01].

Mediated Moderation Models: Is Executive Functioning the Mediating Link between Language Delay in Interaction with Bilingualism on ADHD Diagnosis

Figure 2 presents the path diagram of the mediated moderation model. Results indicate that the indirect effect of language delay X bilingual exposure to ADHD, via the DCCS or Snack-Delay, were not significant. Indeed, the indirect effect of language delay to ADHD diagnosis via either of the executive functioning measures of DCCS or Snack Delay, when probed at the levels of bilingual exposure previously used to probe the significant interaction, continued to not show significance (i.e. -1, 0, +1 SD, see Table 2). It is possible that this lack of indirect effect may be due to a relatively higher degree of measurement error present in multiply imputed DCCS values. Multiple imputation assigns values to all individuals with missing data, even children who would potentially have had valid missing values due to poor performance on DCCS pre-switch. Still, indirect effects remained null in analysis restricted to only children who attempted and passed pre-switch (see supplement S3). Finally, the direct effect of language delay X bilingual exposure to ADHD diagnosis continued to remain significant ($b = -0.10$, OR = 0.90, $p = .026$).

Fig. 2: Path diagram of adjusted moderated mediation SEM models ($n = 408$) with unstandardised beta and odds ratio coefficients for continuous and categorical outcomes except for paths pertaining to covariate adjustments for clarity. Note: LD = Language Delay Status, Bil = Bilingual Exposure Score, DCCS = Dimensional Change Card Sort, SD = Snack Delay, ADHD = ADHD diagnosis, Covariates = Gender, SES, ODD diagnosis, Ethnicity, Age, Cognitive Scores

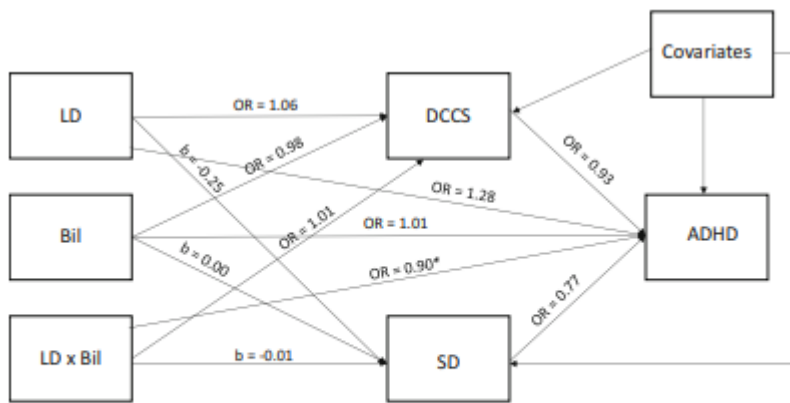

Note: LD = Language Delay Status, Bil = Bilingual Exposure Score, DCCS = Dimensional Change Card Sort, SD = Snack Delay, ADHD = ADHD diagnosis, Covariates = Gender, SES, ODD diagnosis, Ethnicity, Age, Cognitive Scores

Discussion

This study is the first to investigate low language proficiency and its prospective relations to ADHD across toddlers varying in levels of bilingual exposure. In this community sample ($n = 408$), the relation of language delay to ADHD was dependent on bilingualism. Only among toddlers exposed to a single language, did language delayed toddlers show a higher odds of ADHD compared to typical language counterparts 2 ½ years later. These results continued to hold after adjustment for multiple covariates including SES, gender, cognitive ability, ethnicity, age and ODD diagnosis.

We observed language delay to be prospectively associated with an increased odds of ADHD, though only among toddlers who were exposed to a single language. Thus, we cautiously suggest that early language delay may be a risk factor for ADHD among monolingual toddlers, consistent with some (Petersen et al. 2015), but not all (Rescorla et al. 2007), work concerning prospective relations between language delay and attention problems. Differences with some past findings (e.g. Rescorla et al. 2007) may have arisen for one of two reasons. First, in contrast to past research, our use of a fully structured diagnostic schedule affords greater specificity to symptoms of ADHD. In addition, some of the inconsistency in past research may have been due to the unwitting inclusion of children from bilingual backgrounds. Here, we actively assessed bilingualism, and so our results may better capture the “true” relation between language delay and ADHD in monolingual (and, separately, bilingual) children. Still, these single language exposed toddlers, living in a predominately bilingual country, may differ from their monolingual counterparts in monolingual societies. Moreover, analyses did not adjust for initial levels of inattention or hyperactivity, warranting caution and the need for replication.

Higher bilingual exposure afforded protection with regard to ADHD where the pattern of moderation indicated a ‘blunting’ of the elevated association of language delay to ADHD diagnosis. Existing recommendations, originating from studies investigating bilingualism and language impairment (Kay-Raining Bird et al. 2016), state that bilingual toddlers should not, defacto, be advised to ‘drop’ one language, as bilingualism does not necessarily lead to greater impairment. Our findings, if replicated, extend the evidence base for these recommendations to ADHD, as well as their applicability to clinicians such as psychologists and/or pediatricians working with young children with language delay suspected of ADHD from bilingual backgrounds.

Still, it would be premature to recommend exposure to or the teaching of a second language to monolingual language-delayed children in the hopes that it would reduce ADHD. Learning a second language is not an effortless process for children with typical language development, let alone children with language delay/of

low language proficiency. Another alternative that may be considered is executive functioning training. Indeed, a recent study (Vugs et al. 2017) reported language impaired children had improvements in attentional control following such training. Yet, our results do not suggest that executive functioning at 3.5 predicts ADHD at 4.5. As expanded upon below, the mechanism through which bilingualism moderates ADHD diagnosis and symptoms remains unclear.

In keeping with our hypothesis, language delay in toddlers even at maximal levels of ‘balanced bilinguals’ did not associate with ADHD. Unexpectedly, the protective/moderating effect of bilingual exposure could not be accounted for by executive functioning. This is clearly shown by the null results of the indirect effects of language delay to either Snack Delay performance or DCCS accuracy to ADHD outcomes, at -1 , 0 and $+1$ SD levels of bilingual exposure. This is unlike a previous study (Petersen et al. 2015), which found the relation between language ability and symptoms of inattention/ hyperactivity among toddlers, to be significantly mediated by a task requiring the inhibition of highly learned rules.

Also unexpected was that higher levels of bilingual exposure were found to associate with the presence of ADHD among typical language toddlers. This finding is not entirely unprecedented as emerging evidence on bilingualism suggests it is a possible additional cognitive load for ADHD. Among adults, Bialystok et al. (2017) reported that monolingual undergraduates with a clinical diagnosis of ADHD outperformed their bilingual counterparts on a task of response inhibition, a stop signal task. This task requires the participant to inhibit their previous response pattern to press a button on the keyboard upon hearing ‘stop’, and like other tasks here is a task of executive function which associates with ADHD (Willcutt et al. 2005). This possibility of bilingual exposure as a cognitive load is also consistent with the small, but significant effect of bilingual exposure associating with the DCCS in the overall sample ($r = -0.21$). We thus explored this possibility further by conducting a post-hoc analysis of the indirect effect of bilingual exposure \rightarrow executive function \rightarrow ADHD (Online Supplement S4). However, the aforementioned indirect effect was not significant in a sample restricted to only typical language toddlers.

Both these findings, of bilingual exposure mitigating the risk of language delay to ADHD, and its association with ADHD among typical language children, could not be explained by executive functions in the current study. These discrepant findings may have to do with possible specificity in effects of executive functions. Bialystok et al. (2017) reported findings with the Stop Signal Task, which specifically measures response inhibition. Although this overlaps with the DCCS and Snack Delay, the former is typically considered a measure of shifting (Miyake et al. 2000) and the latter requires the inhibition of reward seeking behavior. Moreover, in the previous study which reported mediation of language \rightarrow executive function \rightarrow ADHD (Petersen et al. 2015), cognitive measures in addition to executive function, such as working memory or self-directed speech, may have been measured. This is especially so for one of their three measures, the ‘Grass/Snow’ task. Children touch a green square when told ‘snow’ and a white square when told ‘grass’. In contrast, in our research, experimenters labeled the relevant card dimension (e.g. this is a cake one, where does it go?) in the DCCS and repeated task instructions in Snack Delay (e.g. ‘wait until I ring the bell... before you reach for the snack’) before each trial. Thus, within our study, participants may have used comparatively less self-directed speech to resolve conflicting information. Finally, the expected pass rates on the DCCS of 29.2 to 34.9% (see Table 1) appear slightly lower than the average pass rate of 36% estimated across 37 studies of similarly aged children (Landry et al. 2017). Taken together, then, an association may have arisen had we utilized the exact same executive functioning tasks and/or assessed the mediational path in older Singaporean children. Future research should examine whether factors of age and task specificity can account for differential associations between bilingualism, executive function, and ADHD among typical and language delayed children.

In the current research, only the children with language delay, but not children with typical language development, were buffered from ADHD outcomes by increased bilingual exposure. This is contrary to prior work (Engel de Abreu et al. 2014) which suggests a bilingual advantage in executive functioning among

typical language children as they are also expected to have practice in thinking in and using two languages. This pattern of moderation, coupled with null indirect effects through measures of executive functioning, leads us to consider the possibility of non-cognitive mechanisms in post-hoc hypotheses of ‘accommodation’ and ‘transience’.

This sample is from a society where bilingualism is the norm (Singapore Department of Statistics 2011), and is encouraged by governmental policy. Parents may be exposed to beliefs that bilingual exposed children take longer to develop language skills, despite ultimately catching-up with monolingual peers. Therefore, parents may be more accommodating of language delay among bilinguals (Gupta and Chandler 1993) than their monolingual counterparts. As adults have been shown to have negative perceptions of language impaired children (Shimko et al. 2019), a more accommodating parental perception among bilingual children with language delay may allow them to interact and socialise with peers and adults free from the negative label of a language delay. Such normative interaction may in turn assist in the development of self-regulatory and attentional abilities (Moriguchi 2014), reducing risk of ADHD as compared to monolingual children with language delay. Future work, then, should directly collect information on children’s exposure to social stigma as a potential mediator of the association between language delay and ADHD.

It may also be that language delays among bilinguals are more transient, such that any detrimental effects of language delay on ADHD are minimised for bilinguals. For example, a recent study (Collins et al. 2014) reports that only 28.3% of sequential bilinguals with low proficiency at school entry continued in this category two years later. Still, language delay may not be as transient among simultaneous bilinguals exposed to both languages from a young age (Kay-Raining Bird et al. 2016) such as in this sample. No study to date has compared the persistence of language delay across differing bilingual backgrounds and future studies may do so in relation to symptoms of ADHD.

Although bilingualism is a multi-faceted construct, at this age of two, commonly measured aspects of bilingualism such as reading and writing bilingual proficiency have yet to develop. Thus, consistent with studies of bilingual toddlers, this study defines bilingualism through a single measure of bilingual language exposure (e.g. Brito et al. 2014; Byers-Heinlein et al. 2017; DeAnda et al. 2016; Hoff et al. 2012). Still, verbal language at this age is developing and its proficiency could be further incorporated into future research. Such future work may also shed light upon why, in our current investigation of exposure (and not ability), we did not observe expectable relations between bilingualism and executive functioning.

Measures used in the study were comprehensive as they spanned both parent and child report and involved direct laboratory based assessments. Still, these involved categorical measures of continuous constructs such as language proficiency, executive function, and problems of inattention and hyperactivity. Yet, our sample is larger than existing studies and guards against low power. Also, the fidelity of assessment measures may be impinged upon due to their use among a multilingual Southeast Asian population. Still, measures were forward and backward translated, and administered by bilingual speakers of Southeast Asian nationality. In the case of language delay, its measure was subjected to psychometric validity testing which further reduced bias (Goh et al. 2017). Thus, this study represents a strong first estimate of the relation and mechanisms between language delay and ADHD among a predominately bilingual population.

In conclusion, bilingual exposure was observed to moderate the prospective association between language delay and ADHD, as this was only present for toddlers exposed to one language. However, this finding could not be explained by an expectable ‘bilingual advantage’ as differential performance on measures of executive functioning including DCCS and Snack Delay was not observed. Moreover, only among children with typical language development did bilingual exposure associate with an increased odds of ADHD diagnosis. Future studies investigating post hoc hypotheses on the role of bilingualism as an additional cognitive load for

ADHD among children with typically developing language, and as masking social stigma or increasing the transience of language delay, are needed.

Acknowledgments This research is supported by the Singapore National Research Foundation under its Translational and Clinical Research (TCR) Flagship Programme and administered by the Singapore Ministry of Health's National Medical Research Council (NMRC), SingaporeNMRC/TCR/004-NUS/2008; NMRC/TCR/012-NUHS/2014; NMRC/CBRG/0039/2013; BMRC-SPF 2013/002 and Singapore MOE 2012-T2-2-130. Additional funding is provided by the Singapore Institute for Clinical Sciences, Agency for Science Technology and Research (A*STAR), Singapore.

The GUSTO study group includes Allan Sheppard, Amutha Chinnadurai, Anne Eng Neo Goh, Anne Rifkin-Graboi, Anqi Qiu, Arijit Biswas, Bee Wah Lee, Birit F.P. Broekman, Boon Long Quah, Borys Shuter, Chai Kiat Chng, Cheryl Ngo, Choon Looi Bong, Christiani Jeyakumar Henry, Claudia Chi, Cornelia Yin Ing Chee, Yam Thiam Daniel Goh, Doris Fok, E Shyong Tai, Elaine Tham, Elaine Quah Phaik Ling, Evelyn Chung Ning Law, Evelyn Xiu Ling Loo, Fabian Yap, Falk Mueller-Riemenschneider, George Seow Heong Yeo, Helen Chen, Heng Hao Tan, Hugo P S van Bever, Iliana Magiati, Inez Bik Yun Wong, Ivy Yee-Man Lau, Izzuddin Bin Mohd Aris, Jeevesh Kapur, Jenny L. Richmond, Jerry Kok Yen Chan, Joanna D. Holbrook, Joanne Yoong, Joao N. Ferreira., Jonathan Tze Liang Choo, Jonathan Y. Bernard, Joshua J. Gooley, Keith M. Godfrey, Kenneth Kwek, Kok Hian Tan, Krishnamoorthy Niduvaje, Kuan Jin Lee, Leher Singh, Lieng Hsi Ling, Lin Lin Su, Ling-Wei Chen, Lourdes Mary Daniel, Lynette P Shek, Marielle V. Fortier, Mark Hanson, Mary Foong-Fong Chong, Mary Rauff, Mei Chien Chua, Melvin Khee-Shing Leow, Michael Meaney, Mya Thway Tint, Neerja Karnani, Ngee Lek, Oon Hoe Teoh, P. C. Wong, Paulin Tay Straughan, Peter D. Gluckman, Pratibha Agarwal, Queenie Ling Jun Li, Rob M. van Dam, Salome A. Rebello, Seang-Mei Saw, See Ling Loy, S. Sendhil Velan, Seng Bin Ang, Shang Chee Chong, Sharon Ng, Shiao-Yng Chan, Shirong Cai, Shu-E Soh, Sok Bee Lim, Stella Tsotsi, Chin-Ying Stephen Hsu, Sue Anne Toh, Swee Chye Quek, Victor Samuel Rajadurai, Walter Stunkel, Wayne Cutfield, Wee Meng Han, Wei Wei Pang, Yap-Seng Chong, Yin Bun Cheung, Yiong Huak Chan and Yung Seng Lee.

Compliance with Ethical Standards

Conflict of Interest: The author's declare that they have no conflict of interest.

Ethical Approval: All procedures performed in studies involving human participants were in accordance with the ethical standards of the institutional and/or national research committee and with the 1964 Helsinki declaration and its later amendments or comparable ethical standards.

Informed Consent: Informed consent was obtained from all individual participants included in the study.

References

- Allison, C., Baron-Cohen, S., Wheelwright, S., Charman, T., Richler, J., Pasco, G., & Brayne, C. (2008). The Q-CHAT (Quantitative Checklist for Autism in Toddlers): A normally distributed quantitative measure of autistic traits at 18–24 months of age: Preliminary report. *Journal of Autism and Developmental Disorders*, 38(8), 1414–1425.
- Baddeley, A. (2003). Working memory and language: An overview. *Journal of Communication Disorders*, 36(3), 189–208. [https://doi.org/10.1016/S0021-9924\(03\)00019-4](https://doi.org/10.1016/S0021-9924(03)00019-4).
- Barkley, R. A. (1997). Behavioral inhibition, sustained attention, and executive functions: Constructing a unifying theory of ADHD. *Psychological Bulletin*, 121(1), 65–94. <https://doi.org/10.1037/0033-2909.121.1.65>.
- Bayley, N. (2006). *Bayley scales of infant and toddler development: Administration manual*. Harcourt Assessment.
- Bialystok, E. (2015). Bilingualism and the development of executive function: The role of attention. *Child Development Perspectives*, 9(2), 117–121. <https://doi.org/10.1111/cdep.12116>.

- Bialystok, E., Craik, F. I. M., & Luk, G. (2012). Bilingualism: Consequences for mind and brain. *Trends in Cognitive Sciences*, 16(4), 240–250. <https://doi.org/10.1016/j.tics.2012.03.001>.
- Bialystok, E., Hawrylewicz, K., Wiseheart, M., & Toplak, M. (2017). Interaction of bilingualism and attention-deficit/hyperactivity disorder in young adults. *Bilingualism: Language and Cognition*, 20(03), 588–601. <https://doi.org/10.1017/S1366728915000887>.
- Bialystok, E., & Martin, M. M. (2004). Attention and inhibition in bilingual children: Evidence from the dimensional change card sort task. *Developmental Science*, 7(3), 325–339. <https://doi.org/10.1111/j.1467-7687.2004.00351.x>.
- Brito, N. H., Sebastián-Gallés, N., & Barr, R. (2014). Differences in language exposure and its effects on memory flexibility in monolingual, bilingual, and trilingual infants. *Bilingualism: Language and Cognition* (November 2015), 1–13. <https://doi.org/10.1017/S1366728914000789>.
- Byers-Heinlein, K., Morin-Lessard, E., & Lew-Williams, C. (2017). Bilingual infants control their languages as they listen. *Proceedings of the National Academy of Sciences*, 114(34), 9032–9037.
- Carlson, S. M., & Meltzoff, A. N. (2008). Bilingual experience and executive functioning in young children. *Developmental Science*, 11(2), 282–298. <https://doi.org/10.1111/j.1467-7687.2008.00675.x>.
- Collins, B. A., O'Connor, E. E., Suárez-Orozco, C., Nieto-Castañón, A., & Toppelberg, C. O. (2014). Dual language profiles of Latino children of immigrants: Stability and change over the early school years. *Applied PsychoLinguistics*, 35(3), 581–620. <https://doi.org/10.1017/S0142716412000513>.
- Curtis, P. R., Kaiser, A. P., Estabrook, R., & Roberts, M. Y. (2019). The longitudinal effects of early language intervention on children's problem behaviors. *Child Development*, 90(2), 576–592.
- DeAnda, S., Bosch, L., Poulin-Dubois, D., Zesiger, P., & Friend, M. (2016). The language exposure assessment tool: Quantifying language exposure in infants and children. *Journal of Speech, Language, and Hearing Research*, 59(6), 1346–1356.
- Diamond, A. (2014). Executive functions. *Annual Review of Clinical Psychology*, 64, 135–168. <https://doi.org/10.1146/annurev-psych113011-143750>.
- Enders, C. K., Baraldi, A. N., & Cham, H. (2014). Estimating interaction effects with incomplete predictor variables. *Psychological Methods*, 19(1), 39–55.
- Engel de Abreu, P. M. J., Cruz-Santos, A., & Puglisi, M. L. (2014). Specific language impairment in language-minority children from low-income families. *International Journal of Language & Communication Disorders*, 49(6), 736–747. <https://doi.org/10.1111/1460-6984.12107>.
- Fisher, P., & Lucas, C. (2006). *Diagnostic interview schedule for children (DISC-IV)-young child*. New York: Columbia University.
- Goh, S. K. Y., Tham, E. K. H., Magiati, I., Sim, L., Sanmugam, S., Qiu, A., et al. (2017). Analysis of item-level Bias in the Bayley-III language subscales: The validity and utility of standardized language assessment in a multilingual setting. *Journal of Speech, Language, and Hearing Research*, 60(9), 2663–2671.
- Graham, J. W. (2009). Missing data analysis: Making it work in the real world. *Annual Review of Psychology*, 60, 549–576. <https://doi.org/10.1146/annurev.psych.58.110405.085530>.
- Green, D. W., & Abutalebi, J. (2013). Language control in bilinguals: The adaptive control hypothesis. *Journal of Cognitive Psychology*, 25(5), 515–530. <https://doi.org/10.1080/20445911.2013.796377>.
- Grosjean, F. (2015). *Bilingual: Life and reality*. Cambridge: Harvard University Press. <https://doi.org/10.4159/9780674056459>.
- Gupta, A. F., & Chandler, H. (1993). Paediatric speech and language therapy referral in Singapore: Implications for multilingual language disability. *European Journal of Disorders of Communication*, 7, 311–317.
- Ho, T., Leung, P. W., Lee, C., Tang, C., Hung, S., Kwong, S., Lucas, C. P., Lieh-Mak, F., & Shaffer, D. (2005). Test-retest reliability of the Chinese version of the diagnostic interview schedule for children version

- 4 (DISC-IV). *Journal of Child Psychology and Psychiatry*, 46(10), 1135–1138. <https://doi.org/10.1111/j.1469-7610.2005.01435.x>.
- Hoff, E., Core, C., Place, S., Rumiche, R., Señor, M., & Parra, M. (2012). Dual language exposure and early bilingual development. *Journal of Child Language*, 39(1), 1–27. <https://doi.org/10.1017/S0305000910000759>.
- Iluz-Cohen, P., & Walters, J. (2012). Telling stories in two languages: Narratives of bilingual preschool children with typical and impaired language. *Bilingualism: Language and Cognition*, 15(01), 58–74. <https://doi.org/10.1017/S1366728911000538>.
- Kaufman, A., & Kaufman, N. L. (2004). *Kaufman brief intelligence test* (2nd ed.). Bloomington, MN: Pearson.
- Kay-Raining Bird, E., Genesee, F., & Verhoeven, L. (2016). Bilingualism in children with developmental disorders: A narrative review. *Journal of Communication Disorders*, 63, 1–14. <https://doi.org/10.1016/j.jcomdis.2016.07.003>.
- Kochanska, G., Murray, K., Jacques, T. Y., Koenig, A. L., & Vandegest, K. A. (1996). Inhibitory control in young children and its role in emerging internalization. *Child Development*, 67(2), 490–507. <https://doi.org/10.1111/j.1467-8624.1996.tb01747.x>.
- Kofler, M. J., Irwin, L. N., Soto, E. F., Groves, N. B., Harmon, S. L., & Sarver, D. E. (2018). Executive functioning heterogeneity in pediatric ADHD. *Journal of Abnormal Child Psychology*, 47, 273–286. <https://doi.org/10.1007/s10802-018-0438-2>.
- Kovács, A. M., & Mehler, J. (2009). Cognitive gains in 7-month-old bilingual infants. *Proceedings of the National Academy of Sciences of the United States of America*, 106(16), 6556–6560. <https://doi.org/10.1073/pnas.0811323106>.
- Kuhn, L. J., Willoughby, M. T., Vernon-Feagans, L., Blair, C. B., Cox, M., Blair, C., et al. (2016). The contribution of children’s timespecific and longitudinal expressive language skills on developmental trajectories of executive function. *Journal of Experimental Child Psychology*, 148, 20–34. <https://doi.org/10.1016/j.jecp.2016.03.008>.
- Landry, O., Al-Taie, S., & Franklin, A. (2017). 3-year-olds’ perseveration on the DCCS explained: A meta-analysis. *Journal of Cognition and Development*, 18(4), 419–440.
- Lavigne, J. V., LeBailly, S. A., Hopkins, J., Gouze, K. R., & Binns, H. J. (2009). The prevalence of ADHD, ODD, depression, and anxiety in a community sample of 4-year-olds. *Journal of Clinical Child & Adolescent Psychology*, 38(3), 315–328. Retrieved from <http://www.tandfonline.com/doi/abs/10.1080/15374410902851382>.
- Miyake, A., Friedman, N. P., Emerson, M. J., Witzki, A. H., Howerter, A., & Wager, T. D. (2000). The Unity and Diversity of executive functions and their contributions to complex “frontal lobe” tasks: A latent variable analysis. *Cognitive Psychology*, 41(1), 49–100. <https://doi.org/10.1006/cogp.1999.0734>.
- Moriguchi, Y. (2014). The early development of executive function and its relation to social interaction: A brief review. *Frontiers in Psychology*, 5(April), 388. <https://doi.org/10.3389/fpsyg.2014.00388>.
- Muthén, L. K., & Muthén, B. O. (2017). *Mplus User’s guide*. Eighth edition. Los Angeles, CA: Muthén & Muthén. <https://doi.org/10.1111/j.1600-0447.2011.01711.x>.
- Paap, K. R., Johnson, H. A., & Sawi, O. (2015). Bilingual advantages in executive functioning either do not exist or are restricted to very specific and undetermined circumstances. *Cortex; a Journal Devoted to the Study of the Nervous System and Behavior*, 69, 265–278. <https://doi.org/10.1016/j.cortex.2015.04.014>.
- Pauli-Pott, U., & Becker, K. (2011). Neuropsychological basic deficits in preschoolers at risk for ADHD: A meta-analysis. *Clinical Psychology Review*, 31(4), 626–637. <https://doi.org/10.1016/j.cpr.2011.02.005>.
- Pauls, L. J., & Archibald, L. M. D. (2016). Executive functions in children with specific language impairment: A meta-analysis. *Journal of Speech Language and Hearing Research*, 59(5), 1074. https://doi.org/10.1044/2016_JSLHR-L-15-0174.

- Petersen, I. T., Bates, J. E., D'Onofrio, B. M., Coyne, C. A., Lansford, J. E., Dodge, K. A., et al. (2013). Language ability predicts the development of behavior problems in children. *Journal of Abnormal Psychology, 122*(2), 542–557. <https://doi.org/10.1037/a0031963>.
- Petersen, I. T., Bates, J. E., & Staples, A. D. (2015). The role of language ability and self-regulation in the development of inattentive-hyperactive behavior problems. *Development and Psychopathology, 27*(1), 221–237. <https://doi.org/10.1017/S0954579414000698>.
- Poulin-Dubois, D., Blaye, A., Coutya, J., & Bialystok, E. (2011). The effects of bilingualism on toddlers' executive functioning. *Journal of Experimental Child Psychology, 108*(3), 567–579. <https://doi.org/10.1016/j.jecp.2010.10.009>.
- Preacher, K. J., Rucker, D. D., & Hayes, A. F. (2007). Addressing moderated mediation hypotheses: Theory, methods, and prescriptions. *Multivariate Behavioral Research, 42*(1), 185–211. <https://doi.org/10.1080/00273170701341316>.
- Rescorla, L., Ross, G. S., & McClure, S. (2007). Language delay and behavioral/emotional problems in toddlers: Findings from two developmental clinics. *Journal of Speech Language and Hearing Research, 50*(4), 1063. [https://doi.org/10.1044/1092-4388\(2007/074\)](https://doi.org/10.1044/1092-4388(2007/074)).
- Russell, A. E., Ford, T., Williams, R., & Russell, G. (2016). The association between socioeconomic disadvantage and attention deficit/hyperactivity disorder (ADHD): A systematic review. *Child Psychiatry & Human Development, 47*(3), 440–458. <https://doi.org/10.1007/s10578-015-0578-3>.
- Russell, G., Rodgers, L. R., Ukoumunne, O. C., & Ford, T. (2014). Prevalence of parent-reported ASD and ADHD in the UK: Findings from the millennium cohort study. *Journal of Autism and Developmental Disorders, 44*(1), 31–40.
- Seaman, S. R., Bartlett, J. W., & White, I. R. (2012). Multiple imputation of missing covariates with non-linear effects and interactions: An evaluation of statistical methods. *BMC Medical Research Methodology, 12*, 46. <https://doi.org/10.1186/1471-2288-12-46>.
- Shimko, A., Redmond, S., Ludlow, A., & Ash, A. (2019). Exploring gender as a potential source of bias in adult judgments of children with specific language impairment and attention-deficit/hyperactivity disorder. *Journal of communication disorders*. Advance online publication. <https://doi.org/10.1016/j.jcomdis.2019.105910>.
- Silva, D., Colvin, L., Hagemann, E., & Bower, C. (2014). Environmental risk factors by gender associated with attention-deficit/hyperactivity disorder. *Pediatrics, 133*(1), e14–e22.
- Singapore Department of Statistics. (2011). Census of population 2010 statistical release 1. Demographic Characteristics, Education, Language and Religion. Retrieved from <http://www.singstat.gov.sg/pubn/popn/C2010sr1/cop2010sr1.pdf%5Cnpapers2://publication/uuid/3AF0BC06-396F-43FA-99BA-737E2C60A951>
- Soh, S.-E., Tint, M. T., Gluckman, P. D., Godfrey, K. M., Rifkin-Graboi, A., Chan, Y. H., et al. (2014). Cohort profile: Growing up in Singapore towards healthy outcomes (GUSTO) birth cohort study. *International Journal of Epidemiology, 43*(5), 1401–1409. <https://doi.org/10.1093/ije/dyt125>.
- Sonuga-Barke, E. J. S., Dalen, L., & Remington, B. (2003). Do executive deficits and delay aversion make independent contributions to preschool attention-deficit/hyperactivity disorder symptoms? *Journal of the American Academy of Child & Adolescent Psychiatry, 42*(11), 1335–1342. <https://doi.org/10.1097/01.chi.0000087564.34977.21>.
- St Clair, M. C., Forrest, C. L., Yew, S. G. K., & Gibson, J. L. (2019). Early risk factors and emotional difficulties in children at risk of developmental language disorder: A population cohort study. *Journal of Speech, Language, and Hearing Research, 62*(8), 2750–2771.
- Toppelberg, C. O., Medrano, L., Peña Morgens, L., & Nieto-Castañon, A. (2002). Bilingual children referred for psychiatric services: Associations of language disorders, language skills, and psychopathology. *Journal of the American Academy of Child and Adolescent Psychiatry, 41*(6), 712–722. Retrieved from <http://www.ncbi.nlm.nih.gov/pubmed/12049446>

- Toppelberg, C. O., Nieto-Castañon, A., & Hauser, S. T. (2006). Bilingual children: Cross-sectional relations of psychiatric syndrome severity and dual language proficiency. *Harvard Review of Psychiatry*, 14(1), 15–29.
- Vugs, B., Knoors, H., Cuperus, J., Hendriks, M., & Verhoeven, L. (2017). Executive function training in children with SLI: A pilot study. *Child Language Teaching and Therapy*, 33(1), 47–66. <https://doi.org/10.1177/0265659016667772>.
- Willcutt, E., Doyle, A., Nigg, J., Faraone, S., & Pennington, B. (2005). Validity of the executive function theory of attention-deficit/hyperactivity disorder: A meta-analytic review. *Biological Psychiatry*, 57(11), 1336–1346. <https://doi.org/10.1016/j.biopsych.2005.02.006>.
- Willoughby, M., Kupersmidt, J., Voegler-Lee, M., & Bryant, D. (2011). Contributions of hot and cool self-regulation to preschool disruptive behavior and academic achievement. *Developmental Neuropsychology*. <https://doi.org/10.1080/87565641.2010.549980>.
- Yew, S. G. K., & O’Kearney, R. (2013). Emotional and behavioural outcomes later in childhood and adolescence for children with specific language impairments: Meta-analyses of controlled prospective studies. *Journal of Child Psychology and Psychiatry, and Allied Disciplines*, 54(5), 516–524. <https://doi.org/10.1111/jcpp.12009>.
- Yew, S. G. K., & O’Kearney, R. (2017). Language difficulty at school entry and the trajectories of hyperactivity-inattention problems from ages 4 to 11: Evidence from a population-representative cohort study. *Journal of Abnormal Child Psychology*, 45(6), 1105–1118. <https://doi.org/10.1007/s10802-016-0241-x>.
- Zelazo, P. D. (2006). The dimensional change card Sort (DCCS): A method of assessing executive function in children. *Nature Protocols*, 1(1), 297–301. <https://doi.org/10.1038/nprot.2006.46>