

Back Propagation Neural Network Experiment on Team Matchmaking MOBA game

^{1,2}Evawaty Tanuar

¹Computer Science Department,
School of Computer Science,

²BINUS Graduate Program – Doctor
of Computer Science,
Bina Nusantara University
Jakarta, Indonesia 11480
etanuar@binus.edu

Bahtiar Saleh Abbas

Computer Science Department,
BINUS Graduate Program – Doctor
of Computer Science,
Bina Nusantara University
Jakarta, Indonesia 11480
bahtiars@binus.edu

Agung Trisetiyarso

Computer Science Department,
BINUS Graduate Program – Doctor
of Computer Science,
Bina Nusantara University
Jakarta, Indonesia 11480
atrisetiyarso@binus.edu

Chul-Ho Kang

Computer Science Department,
BINUS Graduate Program – Doctor
of Computer Science,
Bina Nusantara University
Jakarta, Indonesia 11480
chkang5136@kw.ac.kr

Ford Lumban Gaol

Computer Science Department,
BINUS Graduate Program – Doctor
of Computer Science,
Bina Nusantara University
Jakarta, Indonesia 11480
fgaol@binus.edu

^{2,3}Wayan Suparta

²BINUS Graduate Program – Doctor
of Computer Science,
Bina Nusantara University
Jakarta, Indonesia 11480
³Department of Electrical
Engineering,
Sanata Dharma University
Yogyakarta, Indonesia 55282
drwaynesparta@gmail.com

Abstract—Backpropagation is one of the famous method for learning, Implementing Backpropagation techniques in games is part of AI in game. This paper aim to analyzed the best team composition in a Moba Game type in learning using neural network. Mobile Legend: Bang Bang is one of MOBA game for mobile phone. In this experiment, the 2 hidden layers back-propagation neural network algorithm is used to analyze the Mobile Legend game. 5000 training steps was done to reach the stability. This also a way of learning to find the best composition in a team played. Research in area AI and game is very wide and open, a huge opportunity to be explore in future. The objective of this research is to produce the good combination of team which can be resulted in a greater winning chance.

Keywords—back propagation; neural network; AI learning; game; matchmaking

I. INTRODUCTION

Neural network is one of the techniques for learning. Since it first introduced in 1943 by McCulloch and Pitts, neural network was used in several different areas for learning and prediction. A lot of research been done using this method, range from predicting financial, tourism demand and a lot of simulation tools was built to support research using neural network for learning and prediction.

Most of the developer and player focus on the graphical and playable features. The learning and decision side somehow is ignored. The challenges in AI in game are the time allocation for developing AI rather that graphics, the games always change over the time[1]. The rich of data and environment in

game is interested to be learn. Learn about the model also can increase the knowledge and the chance to win a game, also can be implemented as part of the Artificial Intelligence.

II. BACKGROUND

A. Neural Network

Neural network also known as parallel distributed processing, neural computation, it models the brain activity as the basic idea. Inspired by Neuroscience, it contains network of brain cells call neuron. It can calculate corresponding desire input to targeted output[2].

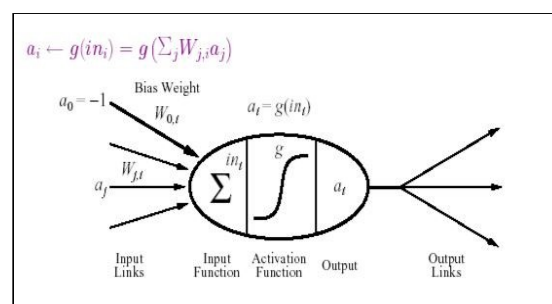

Fig. 1. Model of a Neuron (Russel & Norvey)

Method in Neural Network usually used to know as Feed Forward Method. The process starts from the beginning continue to the next neuron until the output. The formula used are show is the fig 1[3]. First layer usually is the Input Layer,

continue with the Hidden Layers (minimal 1 layer), and the last layer is the Output Layer or for result. Each layer at least contains one or more node and neuron to connect the node.

B. Back Propagation Algorithm

Back Propagation Algorithm follow the feed forward network rules, which have been improved with two main characteristics. The first is the activation function of the hidden unit, and the second is the gradient of the activation function[4].

In short, the neural networks learning procedures are:

- Calculate the values or output units, observed the difference between computed and expected output values
- Start from output layer, moved to hidden layer, propagate and update the weight between the two layers.

Repeat those steps until the desired result or network converges, means that the difference between the expected and the forecast output are in an acceptable range. So, basically it consist of two phases, a forward and a backward pass[5].

Input vectors corresponding to target vector also can be added with bias. Bias is a sigmoid layer are able for approximating the function. There are different methods in deciding the number of neurons, try and error method, rule of thumb, simple method, two phase method and sequential orthogonal approach[6]. From the experiments, can be concluded that if the number of hidden layers increase, the accuracy also increases, but ne network became more complex.

C. MOBA Game – Mobile Legend

MOBA – Multiplayer Online Battle Arena is a sub-genre of the classic Real Time Strategy (RTS) type game. The different is that in this type of gameplay, there is no base construction and players only control on one character[8]. Two teams are fighting to destroy the base of opponent which is at the end of the maps.

The most famous game in this genre is DotA (Defense of the Ancients), by Valve, or Warcraft III: Reign of Chaos, The Frozen Throne, and lately there is Mobile Legend: Bang Bang in Android platform. This genre is the type that eSport tournament very famous about lately. This game mostly played by 2 teams, where each team consists of 5 players with different type of hero. It this why that team matchmaking is important in this type of game.

In Mobile Legend, there are 53 heroes that categorized in 6 types: tank, fighter, assassin, mage, marksman, and support. Also, there are 11 heroes that categorized between 2 types.

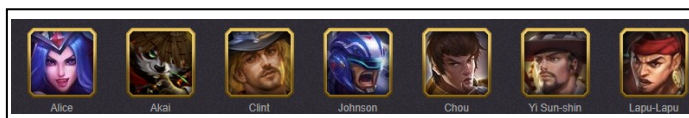

Fig. 2. Some of the heroes in Mobile legend



Fig. 3. Maps of Mobile legend (www.mobilelegends.com)

Typically, the maps of MOBA games shows in fig 3. Two different compete to destroy the opponents.

III. METHODOLOGY

In this research, experiment on Mobile Legend game is conducted to analyze the effectiveness composition of team in the game. The type of the battle are classic and ranked only.

56 team compositions gathered from ranked and classic type competition to be used as data training and testing. Using Neural applet Version 4.3.8, written by Kevin O'neill, et.all from University of British at Columbia[9].

Input is the 6 different types of the heroes, calculated from the type of heroes used by the team, 1 for each hero. For those heroes that in between type, 0.5 was given for each type. For winning team, score 1 for the output, and for the losing team, the output was 0.

Several tests been done. This application using the back-propagation learning algorithms.

IV. EXPERIMENT

A. Experiment Data

To be able to do learning and testing, the data is important. 56 data from 28 games was retrieved from different player with the random possibility method where from player in classic and ranked genre. From the data collected, each type in the team are scored as the definition of character by mobilelegend.com. The average scores for each type of hero that frequently used are:

- Tank: 0.519231
- Fighter: 1.2211

- Assassin: 0.9807
- Mage: 0.84615
- Marksman: 1.3365
- Support: 0.076
- Winning: 0.5

It means that most of the player prefer more on fighter and marksman type hero rather than other. 20 % of the data being used as testing data in this learning experiment.

B. Experiment Process

This research will analyze the 6 – 6 – 3 – 1 formation. 6 input nodes, 2 hidden layers with 6 nodes in the first layer and 3 nodes for the second layers, and 1 node as the result. The result is for predicting the winning or losing possibility. The first one is without bias and second experiment with bias.

These two figures below show the random initialization for 2 different experiments. Fig 4 is the neural network initialization without Bias node and in Fig 5, neural network with Bias node.

C. Experiment Result

For each experiment, 5000 times steps training have been done. The experiment result shows the predictive correction can reach to 90% in the without Bias model compare to with Bias model only reach 86%.

TABLE I. 5000 TRAINING RESULT

Result	Without Bias	With Bias
Training Error	2.3445	3.8542
Test Error	1.2604	1.9656
Predictive Correctly	90%	86%
Predictive Incorrectly	10%	14%

Even that the prediction training error and test error is better from the without Bias model, but the Bias model more stable after the 1000 training compare to without Bias. Shows in the figure below.

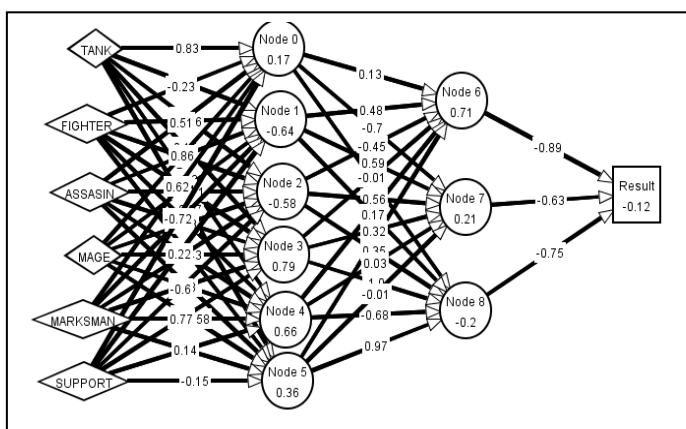

Fig. 4. Neural Network Initialization

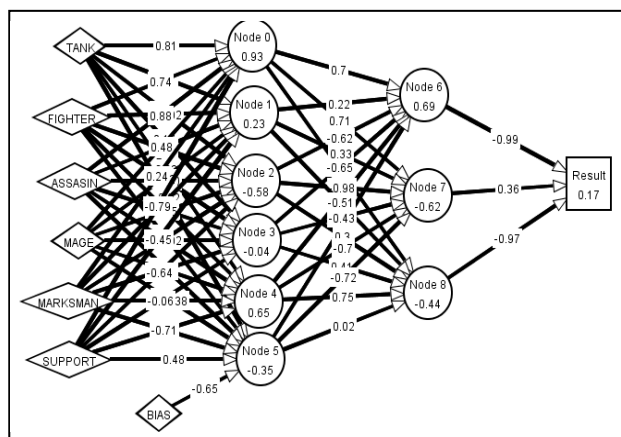

Fig. 5. Neural Network With Bias Initialization

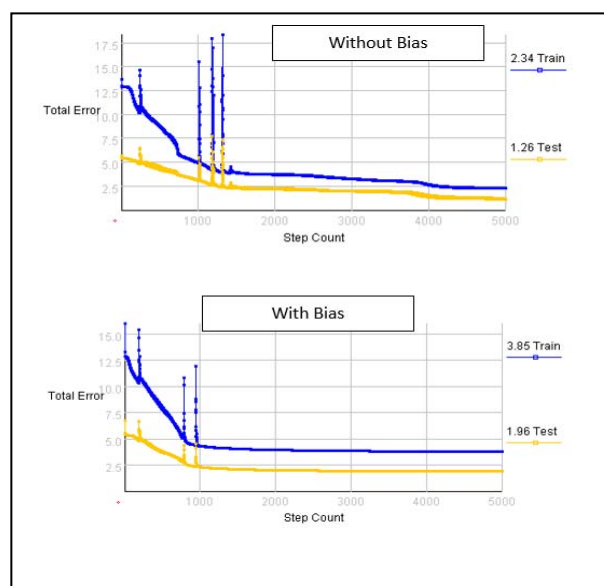

Fig. 6. Result comparison in grafic

D. Team Matching Result

Used the best backpropagation learning result, 90% on experiment 1, the base result calculated as below.

TABLE II. BASE RESULT FOR TYPE IN A TEAM

Tank	Fighter	Assassin	Mage	MM	Support	Result
5	0	0	0	0	0	0.99840
0	5	0	0	0	0	0.00100
0	0	5	0	0	0	0.00070
0	0	0	5	0	0	0.01160
0	0	0	0	5	0	0.86230
0	0	0	0	0	5	0.00000

The type of heroes that influence much in the team are tank and marksman type. Meaning that a team full of support definitely will lose.

126 combinations created from 6 types of heroes with maximum score 3 for each type. The results are categorized as in table III. Only 23 combinations out of 126 results in possibility larger than 0.99% winning chance. Also, only 31 combinations will have a chance to win.

TABLE III. POSSIBILITY TEAM COMBINATION

BP Result	Total Result	Percentage
> 0.9	23	18.25%
> 0.8	28	22.22%
> 0.5	31	24.60%
0	13	10.32%

TABLE IV. BEST TEAM COMBINATION

Tank	Fighter	Assassin	Mage	MM	Support	Result
2	1	1	1	0	0	1
1	2	1	0	1	0	0.9996
0	1	2	1	1	0	0.9997
3	1	0	0	1	0	0.9998

The best team combination as the result from this experiment can be seen in table IV. Another conclusion are:

- Support more than 1 in a team will lose
- 2 tanks in a team will have a bigger chance to win

V. CONCLUSION

This research successfully tested a back-propagation algorithm on the artificial neural network which can be used to predict the best team composition for the Mobile Legend: Bang Bang - MOBA game. From the experiments results, shows that only 24.6% of combination have more that 50% chance to win. It shows that how important to know the team combination as part of a strategy to win a game. In addition, it is necessary to collect more data and be analyzed to understand the components capabilities in order to increase the chances of winning.

From this research can proceed to model the best compositions heroes compete with other formations. This information will capable to improve AI's ability to have a greater chance of winning a game. Also in further research, more data can be gathered and analyzed to have a better understanding the component that able to improve the winning chance. It is true that human or the player ability also impact in the game, but AI in game will only learn from something that can be calculated.

AI in game, neural network, learning and decision making have a huge possibility to be a research area in future.

REFERENCES

- [1] A. S, S. L. H, and P. Gonz, "Game AI for a Turn-based Strategy Game with Plan Adaptation and Ontology-based retrieval," Proceeding DIMEA '08 Proc. 3rd Int. Conf. Digit. Interact. Media Entertain. Arts, no. 642882, pp. 295–302, 2008.
- [2] A. D. Dongare, R. R. Kharde, and A. D. Kachare, "Introduction to Artificial Neural Network," Int. J. Eng. Innov. Technol., vol. 2, no. 1, pp. 189–194, 2012.
- [3] P. Russel, Stuart; Norvey, Artificial intelligence: a modern approach. 2009.
- [4] R. Law, "Back-propagation learning in improving the accuracy of neural network-based tourism demand forecasting," Tour. Manag., vol. 21, pp. 331–340, 2000.
- [5] A. Goyal, G. K. Walia, and S. Kaur, "IMPLEMENTATION OF BACK PROPAGATION ALGORITHM," Int. J. Inf. Technol. Knowl. Manag., vol. 5, no. 2, pp. 429–431, 2012.
- [6] F. S. Panchal and M. Panchal, "Review on Methods of Selecting Number of Hidden Nodes in Artificial Neural Network," Int. J. Comput. Sci. Mob. Comput., vol. 311, no. 11, pp. 455–464, 2014.
- [7] S. V. Kolwankar, "Evolutionary Artificial Intelligence for MOBA / Action-RTS Games using Genetic Algorithms," Int. J. Comput. Appl., pp. 29–31, 2012.
- [8] <https://www.mobilelegends.com/>
- [9] <http://aispace.org>