

Implementation and Testing of Dynamic and Flexible Platoons in Urban Areas

Schindler, Julian¹; Dariani, Reza¹;
Rondinone, Michele²; Walter, Thomas²

¹German Aerospace Center (DLR), Institute of Transportation Systems,
Lilienthalplatz 7, 38108 Braunschweig, Germany

²Hyundai Motor Europe Technical Center GmbH (HMETC), Germany

Tel.: +49 531 295 3510

Fax: +49 531 295 3402

julian.schindler@DLR.de

Abstract

A new way of platooning in urban areas has been presented on the AAET conference last year [1]. The theoretical approach of linking Cooperative Adaptive Cruise Control (C-ACC) to state-machine based platoon coordination has been discussed, which has been developed within the European H2020 project MAVEN (Managing Automated Vehicles Enhances Network, [2]). This approach leads to a maximum of flexibility and a dynamic platoon behavior allowing to cope with the complex situations occurring under urban conditions. Special attention of this development laid on the inclusion of communication – inside the platoon and to possible new members (V2V) and between infrastructure and the platoon (V2I and I2V) to allow coordinated movements through signalized intersections.

During the last year, the theoretical approach has been put into praxis. Several steps had to be taken to reach the goal of driving on public roads in the end. First, simulations had to be performed. Then, an approach based on augmented reality has been chosen to test different scenarios on test tracks without the need of equipping several vehicles with the required hardware for C-ACC-platooning. Afterwards, more real components (traffic lights, other platooning vehicles) were added, until finally test runs could be performed on the public roads of the Tostmannplatz in Braunschweig, which is part of the Application platform for Intelligent Mobility (AIM, [3]).

This paper shows the different test setups and approaches and describes early results of the tests.

Keywords: Urban Platooning, C-ACC, hierarchical traffic management, augmented reality testing

Introduction

Efficiency of traffic systems is a key factor for future mobility. This is especially true for urban road networks in growing cities with the demand of reaching every part of the city in a comfortable and fast way. As the number of vehicles and especially cars is growing in urban areas, new concepts have to be developed to ensure better efficiency. Special focus is needed for the bottlenecks of urban areas: the intersections. The European H2020 project MAVEN is working on such concepts. By using new technologies like vehicle automation, communication and interaction with traffic lights, intersections are transformed into communication hubs, where the needs of all traffic participants are aggregated and the most efficient way to proceed is calculated in a hierarchical way. Signal plans are optimized, and hints for smoother travelling (i.e. lane and speed advices) are given to the vehicles.

A key feature for enhancing efficiency in urban networks is the creation of flexible and dynamic urban platoons of vehicles, which can travel with small distances and depart at each intersection at the same time, enhancing the throughput of each intersection. This concept has been presented on the last year's AAET conference [1], also showing the conceptual differences between highway and urban platooning. Within the project MAVEN, this concept has been put into reality during the last year, leading to fully functional prototypes in Q1/2019, which are going to show the whole system behaviour of an adaptive green light optimal speed advisory (AGLOSA), combined with lane advices and platooning vehicles on the Tostmannplatz intersection located in Braunschweig, Germany.

The prototypes have been developed step by step; starting from basic ideas preliminary tested in simulation environments and finally brought to reality in a set of three test vehicles of Hyundai and DLR able to drive automated on public roads. As communication is the key for urban platooning, a lot effort was put into message set definitions and communication testing. But since the MAVEN project dealt with new algorithms in vehicles and the road side, it was quite challenging to test the complex interactions of all sub systems. Not only automated vehicles on urban roads needed to be developed, which would have been a challenge on its own, but also the interaction schemes of vehicles between each other and between

infrastructure and vehicles. In addition, the future traffic systems will be mixed, having automated but also manual driven vehicles on the road at the same time, requiring different means of interaction and coordination.

To cope with this complexity, several milestones had to be reached and several integration meetings on test tracks and later on public roads took place to allow testing of the components. But it turned out that these kinds of tests will not be enough to cover the complexity of real urban traffic with all of its dimensions in the limited time of the project with its limited resources. Therefore, new testing procedures needed to be developed.

This paper gives an overview on the testing procedures used during the last year until now. After briefly describing the vehicle software architecture and software modules and communication schemes, an overview on Hardware in the Loop (HiL) simulation tests of the communication and the platooning is given. Afterwards, the setup of the vehicles and the test tracks are described, presenting also parts of the platoon related test track testing. This chapter is followed by a chapter on augmented reality testing which allows to get more realistic and complex scenarios on test tracks without endangering the test drivers and vehicles. Finally, the first public road tests are shown and an outlook on the upcoming tests is given.

General vehicle software architecture and V2X protocols

All MAVEN automated vehicles follow a common basic software architecture (“AD software”), composed of interfaces to the sensors and to a high definition map, a sensor data fusion, and modules for trajectory planning and vehicle control, as shown in Figure 1. In addition, a common module “Platoon Logic”, which is handling all platoon related procedures and information, e.g. the process of platoon forming and of platoon breaking in case other vehicles need to change lane to the lane of the platoon, is attached to the AD software. While the AD software differs in implementation between DLR and Hyundai vehicles, the Platoon Logic has been implemented as a common library for both.

In detail, the Platoon Logic includes a set of state machines, which is briefly shown in Figure 2 and has been explained in detail in [1] and [4]. These state machines handle the general platoon state (like “want to form” or “in a platoon”), a forming state (like “currently forming” a platoon), the communication state of platoon related V2X

messages (“sending P(latoon)CAM”) and a state machine responsible for the gap size, the AD software has to keep.

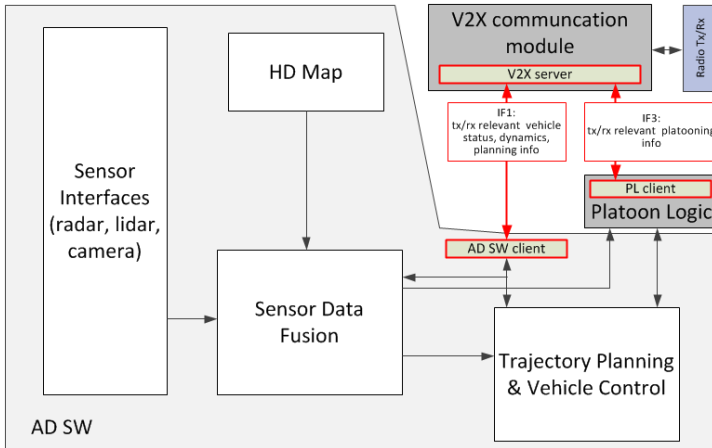

Figure 1: General AD Software modules and MAVEN V2X system integration scheme

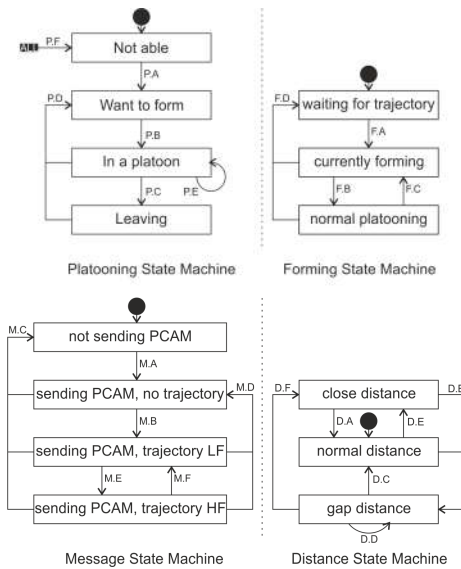

Figure 2: The four different state machines used for platooning

A cooperative system like the one designed in MAVEN needs to have a special focus on communication aspects, as communication is the key to cooperation.

As described in [5], the MAVEN vehicles support transmission and reception of extensions of standard ETSI ITS Cooperative Awareness Messages [6] to implement the platooning use cases. These CAMs are transmitted on parallel radio channels in the 5.9GHz band:

- 1) Extended CAM on SCH0: carries information (planned route, acceleration/braking capability, etc.) for CAVs to detect opportunities to initialize a platoon [1]. This information is contained in an optional special vehicle container called `MAVENAutomatedVehicleContainer`
- 2) Extended CAM on SCHx: carries needed information to manage and control platoons of MAVEN CAVs in a distributed manner [1]. In this CAM, an `AutomatedVehicleContainerHighFrequency` is always included to carry important information that CAVs consider for controlling and executing close-following driving. The `AutomatedVehicleContainerLowFrequency` is included every n messages, mostly with information reflecting the platooning state machine running at each vehicle and used for distributed platoon management. The suitable generation rate for these CAMs as well as the best value for the parameter n (see above) are currently object of investigation in MAVEN. Here, simulations are performed in order to quantify MAVEN platooning performance by varying values of design parameters.

For generation and handling of these CAM messages the DLR and Hyundai vehicles adopt the V2X system integration scheme depicted in Figure 1 before. In general, the V2X communication module has been extended with a software application capable to communicate with external modules for the exchange of specific data structures used for reception and transmission of V2X messages. These data structures are exchanged via UDP socket connections over dedicated interfaces as described in the MAVEN Deliverable 5.1 [7]. In this context, the V2X communication module acts always as a server for the clients implemented in the external modules. The data structures and the adopted interfaces are defined in a specific header file and used as a common reference for proprietary

implementations at all vehicles. Figure 1 also shows the interfacing with the AD SW implemented at either the Hyundai or DLR vehicles, and with the Platoon logic.

Over the interface IF1_AD2V2X, the AD SW continuously provides the V2X communication module with data needed to be V2V exchanged in order to detect opportunities for initializing or joining a platoon. This data is used by the V2X module for populating CAMs on SCH0, namely:

- 1) Standard CAM info (CAV reference position, speed, heading, driving direction, longitudinal acceleration, etc.)
- 2) Lane position
- 3) Acceleration/deceleration capability
- 4) Desired speed range for platooning
- 5) Planned route of intersections to cross
- 6) Planned route at intersection

Over IF1_V2X2AD the AD SW receives the data relative to CAMs on SCH0 received by other CAVs and used by the AD SW sensor fusion modules to increase the environmental awareness of the ego vehicle, namely:

- 1) Standard CAM info (CAV reference position, speed, heading, driving direction, longitudinal acceleration, etc.)

Over IF3_V2X2PL, the Platoon logic receives data structures relative to CAMs received from other CAVs on both SCH0 and SCHx. These structures are needed for the platooning state machine to check the conditions for platoon initialization and state changes (e.g. presence of vehicle behind/ahead with similar route/speed/acceleration capability, platoon ID, Platoon followers and state machine flags (see above)). These structures include, per each remote CAV:

- 1) Standard CAM info (CAV reference position, speed, heading, driving direction, longitudinal acceleration, etc.)
- 2) Lane position
- 3) Acceleration capability
- 4) Desired speed range for platooning
- 5) Planned Route of intersections to cross
- 6) Planned route at intersection (ingress/egress lanes and signal group for planned maneuver at next intersection)
- 7) Platoon identifier
- 8) Local followers in the platoon
- 9) Planned path
- 10) Planned lane
- 11) Platoon state machine flags (as described above)

- 12) Emergency Flag (as described in [1], in case the platoon needs to handle an emergency situation urgently)
- 13) Able to platoon

IF3_PL2V2X is used when the Platoon Logic wants to activate the V2V transmission of CAMs on the SCHx (e.g. the conditions are met to initialize a platoon between two CAVs). In this case it starts providing the following data to the V2X module:

- 1) Platoon identifier
- 2) Local followers in the platoon
- 3) Planned path
- 4) Planned lane
- 5) Platoon state machine flags (as described above)
- 6) Emergency flag

Moreover, IF3_PL2V2X is used to advertise the ability of a vehicle to drive in a platoon. This info is received by the V2X module and transmitted in a CAM on the SCH0 CAMs:

- 1) Able to platoon

Preliminary Simulation Testing

As a starting point, the AD software and the Platoon Logic had to be developed and tested in simulation. At DLR, the AD software which is used in the DLR vehicles was already implemented in the software framework Dominion [8], so that all basic underlying components (environment perception, trajectory planning, controller, etc.) could be preliminary tested in software simulation runs. As input, all simulation tests have been performed using the original high definition maps of the test tracks used for real world testing later on. This ensured highest transferability of results, esp. when looking at the quite complex road topology of the Tostmannplatz intersection, which includes several stop lines and merging areas.

The Platoon Logic library and rudimentary applications for sending and receiving V2X messages in a lossless way have also been implemented and connected to the Dominion environment.

While simulating single vehicle behaviour is comparably simple, simulating the interaction of several vehicles, vehicle automations, infrastructure behaviour and communications turned out to be a challenging task, as it requires several modules which run in parallel and influence each other.

At DLR, this was achieved by first doing individual module tests, and then by combining the modules for each automated vehicle. By

following the MoSAIC approach [8] several automated vehicles could be simulated in the same virtual environment, creating the ability of testing the interaction between the different entities.

After performing first successful tests of the entire simulation network, simulations have been enriched by hardware-in-the-loop (HiL) tests: Each simulated automated vehicle (up to three vehicles in the tests) has been connected to a real Cohda MK5 V2X unit (see Figure 3). By following this approach, the correct interaction between the vehicles using the original communication protocols shown above could be tested.

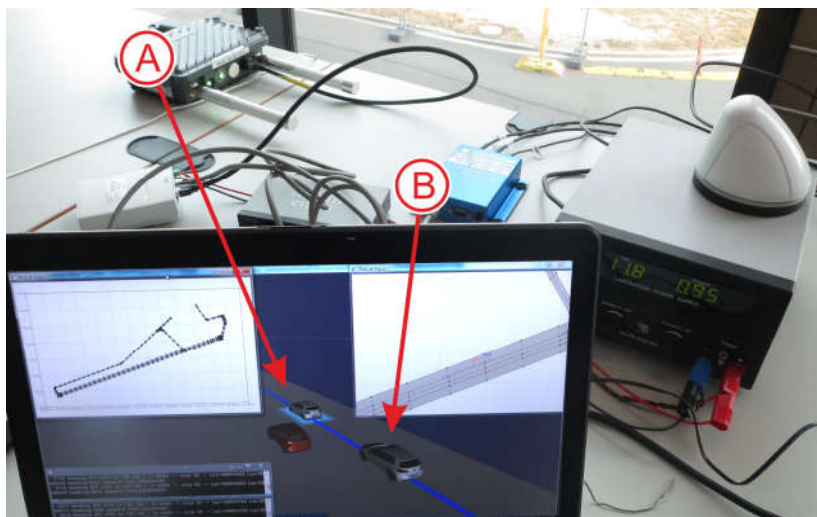

Figure 3: HiL test of Platoon Logic using two Cohda MK5 units (one RSU (A) for the leading vehicle, one OBU (B) for the following). The functionality of RSU and OBU is equal in this test.

From Simulation to Real World Testing on Test Tracks

While the simulation and HiL testing continued, first integration steps into the real world had been done. The following subchapters first show the architecture of the used automated vehicles. Then, the test tracks used for testing the vehicles are introduced. This chapter is concluded by showing details on some of the test runs.

The Hyundai Ioniq test vehicle

The Hyundai vehicle used for testing is a series Ioniq vehicle enhanced with sensors and computing equipment that are not experimental samples but either already installed in series vehicles, or are close to be. This setup is composed by the following sensors:

On-board sensors:

- 1x Ibeo front + 1x Ibeo rear LiDAR + fusion unit
- 1x Mobileye front camera
- 4x Aptiv SRR4 corner radars 1x Aptiv MRR3 front radar + fusion unit

Cooperative sensors:

- 1x Cohda Wireless MK5 OBU (V2X communication module)

Vehicle Localization:

- 1x OXTS DGPS receiver

Moreover, the Hyundai vehicle uses the following automated driving function computing units to host AD function logic:

- 2x ADLINK automotive grade PCs

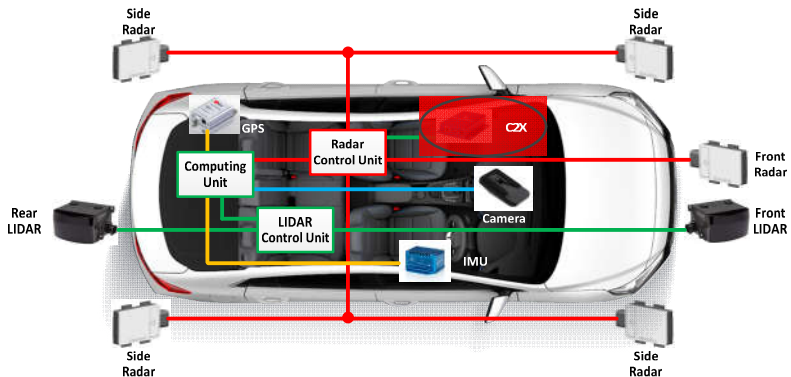

Figure 4: Hyundai Ioniq setup

For easing the understanding of the integration, a basic overview of the Hyundai automated driving software framework implementation (AD SW) running on the AD computing unit is given in the figure below. As it can be seen, the perception system includes a sensor fusion (SF) module collecting inputs from the individual sensors (including the V2X communication module), and provides a

consolidated representation of the environment to the Guidance, Navigation and Control module (GNC). The guidance and control module is devoted to compute the planned trajectory and vehicle control. In this block, the Decision Making Module (DMM) implements maneuver feasibility decisions by cross-checking information about the intended route, obstacle-related threats in the drivable region, and lane and/or speed advices possibly received by the Infrastructure via V2X. As such the DMM is used to drive deceleration/stopping and lane change decisions and hence has an impact on the path and motion and control computation executed by the other modules of the GNC system. Finally, the Platoon Logic module is exactly the same as implemented in the DLR vehicles. It takes inputs by the sensor fusion, vehicle state estimator and path planning module to populate the platooning information to be V2X exchanged with other vehicles. At the same time, it receives similar information via V2X by other cars, and applies it for state machine logic operations, which in turn produces outputs injected in the path planning as well as in updated V2X information.

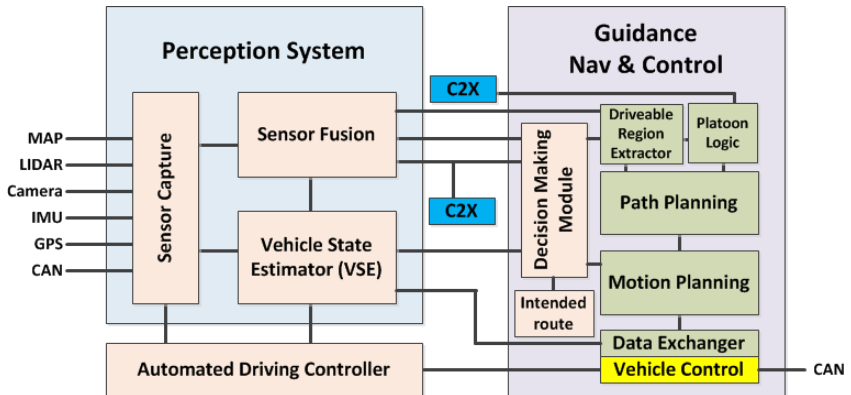

Figure 5: AD software of the Hyundai Ioniq

The DLR test vehicles

Within MAVEN, DLR uses two of its research vehicles for integration and testing. These are a full electric Volkswagen eGolf firming under the name FASCarE and a hybrid Volkswagen Passat GTE firming under the name ViewCar2. Both vehicles have a common platform consisting of a set of sensors (see Figure 6), three automotive PCs and a DSpace Autobox.

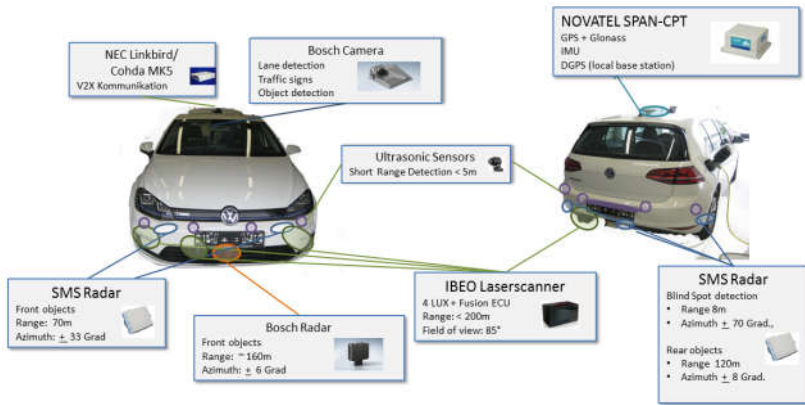

Figure 6: Sensor setup at the FASCarE

As shown in Figure 7, the AD software architecture of the DLR vehicles is quite similar to the one used at the Hyundai vehicle, although modules have partially different name and it is implemented using the Dominion middleware instead. This allows that nearly all software components are unchanged between simulation and test vehicle [8]. Another important difference is that also virtual objects can be fed into the sensor data fusion. This allows augmented reality testing, which is described later on in this paper. Other major differences are located inside the different modules. The DLR vehicles e.g. use a trajectory planner based on optimal control [4].

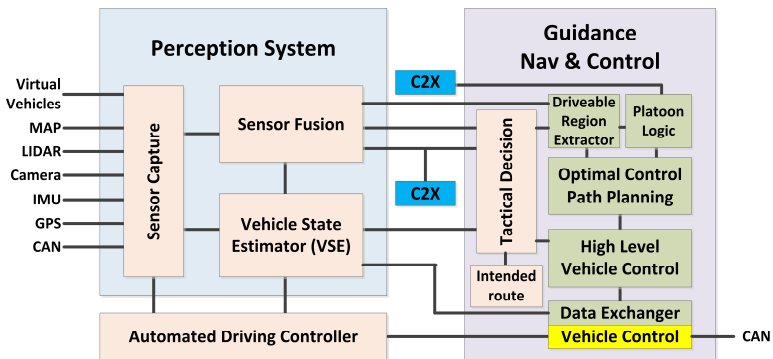

Figure 7: AD software of the DLR vehicles

Test tracks

As the vehicle automation has been implemented at DLR and Hyundai separately, it has been tested on local test tracks individually. DLR uses two test tracks. On the one hand, the DLR grounds in Braunschweig are used for preliminary testing of prototypes. The test ground has an urban character, with all of its positive and negative side effects (buildings, but also pedestrians and parking vehicles). If needed, parts of the grounds can be closed. On the other hand, the test track in Peine-Eddesse, a small closed airfield located between Braunschweig and Hannover, is used for extensive vehicle function testing. This test track allows maximum flexibility, as it has room for testing in different driving speeds and under a fully controlled environment. The runway is used to test vehicle behavior in various different road layouts, which can be set up easily.

DLR owns a mobile traffic light combined with a V2X Road side Unit (RSU) which can be placed on both test tracks if needed.

Another test track, Griesheim Airfield, is used by Hyundai to do similar testing, but is also used for combined testing of Hyundai and DLR vehicles, e.g. initial platooning-related tests involving the DLR and Hyundai vehicles have been taken place at the Griesheim Airfield test site on a closed track. The Griesheim test track is a former military airport, now managed by the Technical University of Darmstadt. It is composed by a runway of approximately 1.2 km and a taxiway of almost the same length.

Testing activity for urban platooning

The testing activities on test tracks started with simple lane following automated driving. The scenarios have been made more and more complex by adding several parts step by step. At first, the mobile traffic light has been placed on the DLR grounds sending out Signal Phase and Timing (SPaT) and MAP extended messages following the newest standard. The vehicles now were able to use the included Green Light Optimal Speed Advisory (GLOSA), leading to an optimal arrival at the intersection (Figure 8). In MAVEN, the GLOSA has been enhanced in a way that the traffic light phases have dynamic durations, taking into account the traffic demand on the intersection. The demand is determined by using induction loops on the track and by receiving the Cooperative Awareness Messages (CAM) sent out by the vehicles [9]. This procedure, called AGLOSA [10], is allowing to take platoons into account while planning the

phases, e.g. by letting them pass without the need of splitting up at a red light.

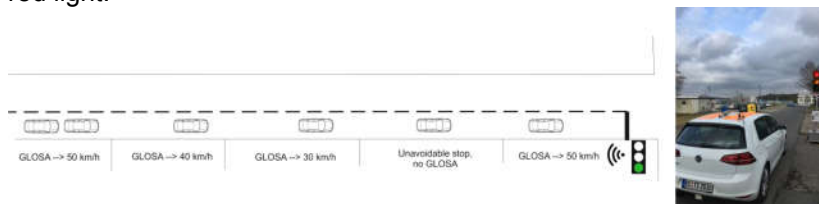

Figure 8: Green Light Optimal Speed Advisory (GLOSA) with mobile traffic light at DLR grounds in Braunschweig

An additional benefit of measuring the traffic on the road is that the traffic light knows about possible queues on each lane at the stop lines. The AGLOSA algorithm of MAVEN takes these queues into account to generate lane advices for the upcoming traffic. For this purpose, a Lane Advice Message (LAM, created in MAVEN [9]) is sent out by the RSU, guiding vehicles individually to the optimal lane to be used at the intersection. The generation of LAMs at the intersection in AGLOSA also takes possible platoon membership into account, avoiding unnecessary platoon splitting.

The combination of speed and lane advices has been tested in Peine-Eddesse intensively.

As third step, the platooning itself (communication and platoon logic) has been tested. After doing first tests with DLR vehicles at DLR grounds, the next step was to perform tests with Hyundai and DLR vehicles together. On the one hand, this step is challenging because of the different vehicle automations implemented, resulting in different individual behaviour. On the other hand, such tests reveal several details which need to be taken into account when planning general approaches.

The initial Hyundai and DLR platooning tests taking place in Griesheim have had the objective of verifying the whole end-to-end communication chain used for platooning initialization and involving the AD SW, platoon logic, and V2X communication modules at two test vehicles. During the tests the vehicles were driving along a pre-defined route between points (A) and (B) shown in Figure 9 below, transmitting the CAMs with MAVEN extensions.



Figure 9: Griesheim test track with route for initial platooning tests

A schematic representation of these tests is depicted in Figure 10. The DLR vehicle drives behind the Hyundai one over the stretch A to B. At each vehicle, the AD SW is configured to transmit the same planned maneuver/route information over the UDP IF1_AD2V2X interface (both vehicles are heading towards a virtual intersection at point B). Moreover, the platooning logic running at both vehicles is configured to indicate the ability for platooning over the UDP IF3_PL2V2X interface. With this configuration, the test verifies that the following three steps are executed correctly (please also refer to Figure 10):

- 1) the AD SW at the DLR car sends its status, dynamics and maneuver/route planning data over IF1_AD2V2X and its ability to platoon over the UDP IF3_PL2V2X interface to the V2X communication module. The V2X module accordingly populates CAMs on the SCH0. These CAMs are received by the Hyundai vehicle's V2X module. The V2X module forwards the IF3_V2X2PL data to the Hyundai platoon logic as well as the IF1_V2X2AD data to the AD SW via UDP communication.

- 2) the platoon logic at the Hyundai car identifies a matching between the maneuver/route data received and its own data. Also, it learns that the DLR vehicle is able to platoon. As the DLR car is detected to be behind at a valid distance to initiate a platoon, then CAMs transmissions on SCHx for platooning management and control can be initiated. For this purpose, the Platoon logic on the Hyundai car starts sending platooning data over the UDP IF3_PL2V2X interface. This data is received by the V2X module, which starts transmitting CAMs on the SCHx in addition to those transmitted on the SCH0.

Both CAM types are received by the DLR vehicle. The receiving V2X module forwards the received Hyundai car's maneuver/route plans and platooning information over the UDP IF3_V2X2PL interface to the platoon logic.

3) the platoon logic on the DLR car processes all the received information and acknowledges the initialization of the platoon by starting transmitting its own platooning information over the UDP IF3_PL2V2X interface. This information is received by the V2X communication module that starts transmitting CAMs on the SCHx on the DLR car as well. The CAMs are received by the Hyundai vehicle: from this moment on the platoon is formed and get controlled thanks to the exchanged V2V information.

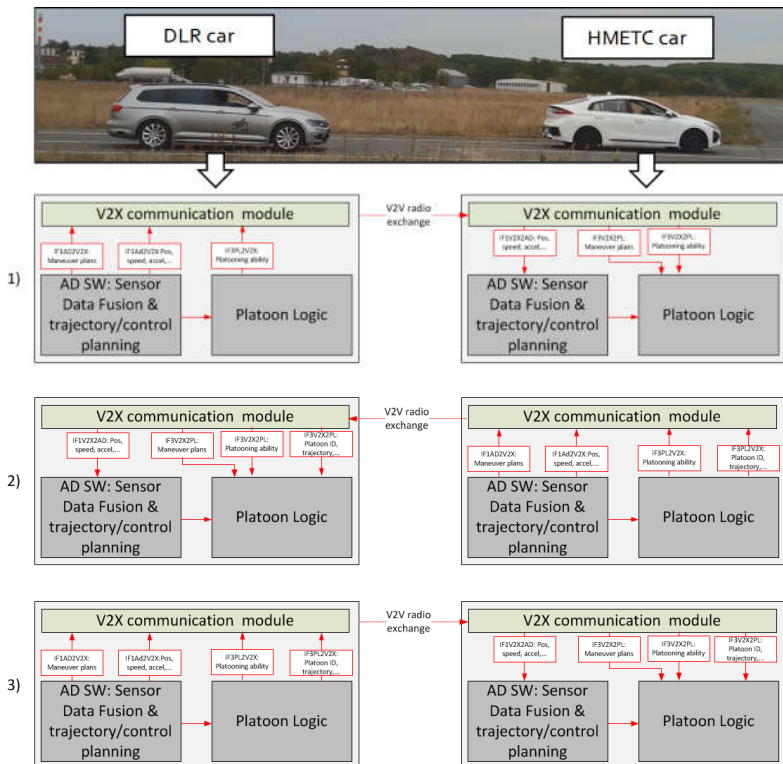

Figure 10: Schematic V2X interaction during platoon tests in Griesheim

Augmented reality for increased complexity testing

As it is quite a large step from testing in a controlled environment on test tracks to testing on public roads with all the possibilities which may occur, it has been decided to have one intermediary step: The enriching of test track scenarios with augmented reality components. Basically, there are two different parts of the test track scenarios which need to be enriched. On the one hand, there is the road layout, which is much more complex in public real world scenarios than the original road layout of the runways on the available test tracks in Eddesse and Griesheim. On the other hand, the number and behaviour of other road users makes a big difference. To cope with both, we first set up a new virtual test track layout, which resembles the layout of the public roads which will be used later on, the Tostmannplatz and the AIM Research Intersection in Braunschweig, see Figure 11. The challenge thereby was to be as close to reality, by only using the available space of the test track. As result, the original road layout has been straightened, and not needed directions of the intersections have been removed. Nevertheless, the layout still includes the various merging areas, turning lanes and other specialities of the real world track.



Figure 11: Virtual test track in Peine-Eddesse

When performing the tests, the virtual test track is only available virtually, i.e. localization on the track can only be done by using differential GPS and the virtual test track as high definition map input to the vehicle automation. If needed, the corresponding lane markings or points of interest can be painted or marked with traffic cones on the test track. This has been done e.g. with outer road borders or stop lines of the traffic lights.

For the MAVEN tests of the interaction with the traffic light in terms of (A)GLOSA, a real traffic light and RSU has been placed on the road at the given position indicated in Figure 11. This traffic light was sending out MAP messages via V2X including the virtual lane layout. Also, SPaT messages were sent including the current phase of the lights and speed advices.

By using the virtual map and the V2X messages, real test vehicles were able to drive on the virtual lanes and follow the speed advices accordingly.

As a next step, virtual road users were introduced. As long as there is only one real test vehicle, this is a simple task. Since the Dominion software used for the vehicle automation is equal in simulators and test vehicles, several applications for producing traffic in a simulated environment were already available. Therefore, only three small modules had to be implemented, as shown in Figure 12:

- 1) The real vehicle had to be placed in the virtual world, so that other road users are able to take it into account while driving around. This has been achieved by simply forwarding the differential GPS position to a simulated vehicle.
- 2) Also the signal phase of the real traffic light has to be included in the simulation, so that simulated vehicles also stop when the real traffic light turns red. This has been achieved by using the SPaT message content and linking it to stop lines available for the simulated vehicles.
- 3) The test vehicle itself needs to take the simulated vehicles into account while planning its trajectories. This has been achieved by adding a “virtual sensor” to the sensor data fusion which forwards the virtual obstacles to the vehicle automation (see Figure 7 earlier in this paper).

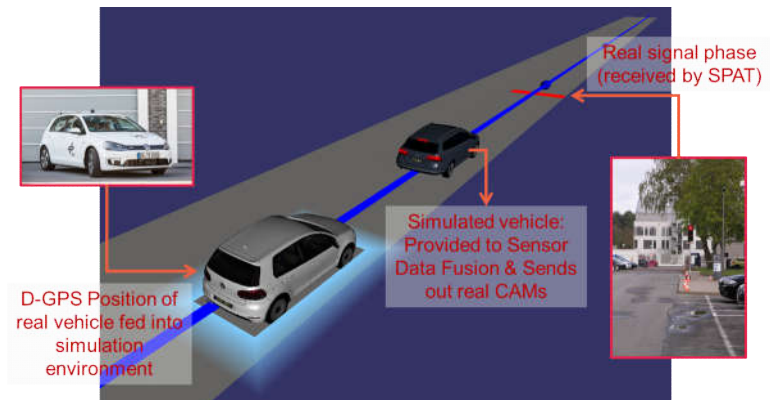

Figure 12: Combining real and virtual components on test tracks.

By using these three modules, several difficult scenarios could be tested like vehicles braking sharply or changing lanes with short

notice without harming the test drivers. But for MAVEN, it still was not enough, as platoons needed to be tested as well. For this purpose, two more difficult steps had to be taken. On the one hand, vehicles had to be added virtually which were also able to platoon and which will form a platoon with the real vehicles. This step was achieved by running two vehicle automations physically in one test vehicle. One is controlling the real car, the other one a virtual car. To be as close as possible to reality, both cars were not communicating via the simulation environment but via V2X. This has been achieved by placing a second V2X On Board Unit (OBU) in the test vehicle, which is using the virtual car position and platoon states for sending. This OBU was communicating with the real test vehicle. In addition, this OBU was receiving the CAMs from the real vehicle and was therefore able to place the real vehicle in its simulated world, allowing to react to it and to build a platoon.

The second step was to use more than one real test vehicle in the tests with augmented reality. This is a very challenging step, as the virtual test environment has to be synchronized in all test vehicles. The synchronization of traffic lights is a simple task, as the traffic light information is sent as broadcast SPaT and received on all test vehicles (since it is a flat airport area, range of V2X messages is not problematic). Other road users are a different story. For MAVEN it has been decided that one test vehicle is acting as simulation server, where the traffic simulation software is running and the virtual road users are created. Then, one OBU was used to send out Cooperative Awareness Messages (CAM) of all of the virtual vehicles. All other test vehicles now were able to receive all of the CAMs. This input has been used as further input to the sensor data fusion, creating objects only based on the CAM position data. By following this way, the virtual vehicles could be used as surrounding road users at several real test vehicles and complex platoon behaviour could be tested as well.

Public road testing

After performing several tests on test tracks with and without augmented reality, the vehicles have been ready for doing tests on public roads. Public road testing also starts with more simple test cases – complexity was raised step by step.

The first tests were dealing with individual vehicle automations able to follow lanes, taking into account surrounding traffic and handling traffic lights. Therefore, Hyundai and DLR performed independent

tests on the Tostmannplatz in Braunschweig training the AD SW planning and control modules to adapt the ego speed to the one dynamically suggested by the AGLOSA traffic light controller running at the Tostmannplatz signalized intersection. For this purpose a preliminary task was the collection/recording of traffic light's phase/timing and speed information transmitted by the Tostmannplatz RSU via V2X SPaT/MAP messages. Figure 13 shows a picture of the Hyundai car during these recording sessions. The V2X communication module converts SPaT and MAP messages into a data structure suitable for the AD SW module needs in terms of GLOSA handling. These data structures are forwarded to the AD SW via UDP over the already mentioned IF1_V2X2AD interface and logged. These recordings represent the dynamic evolution of the traffic light phases and speed advices over a given time window and can be replayed by the AD SW as an additional emulated input for the vehicle automation. The speed adaptation of the automation system has been successfully verified for different combinations of vehicle distances from the stop line and GLOSA recording.



Figure 13: Hyundai tests at the Tostmannplatz in Braunschweig

As next step, platooning is tested on the Tostmannplatz. Therefore, the Hyundai and DLR vehicles interact to build platoons and follow the advices of the traffic light. These tests are scheduled for January and February 2019 and are therefore not done at the point of writing, but results will be available partly at the conference.

Summary and outlook

This paper presented an overview on the test activities done in the MAVEN project to bring urban platooning to public roads. It has been showed that intensive testing on test tracks is a mandatory step, and that augmented reality approaches help to reduce the gap between artificial and controlled test track environments and the complex real life on public roads. As the MAVEN project is still ongoing not all results could be shown already in this paper. Especially the final platoon test results on public roads are not available at the time of writing, but will most likely be presented at the AAET conference.

Acknowledgement

This paper was prepared thanks to project MAVEN (www.maven-its.eu).



This project has received funding from the European Union's Horizon 2020 research and innovation programme under the Grant Agreement No. 690727.

References

- [1] Schindler, J., Dariani, R., Rondinone, M., Walter, T. (2018). Dynamic and Flexible Platooning in Urban Areas, AAET Automatisiertes und vernetztes Fahren, 14.-15. März 2018, Braunschweig, Deutschland
- [2] Vreeswijk, J., Pribyl, O., Hoadley, S. (2017). Managing automated vehicles enhances network. Paper TP0843. In Proceedings: The 12th European Congress on Intelligent Transport Systems. Strasbourg.
- [3] Frankiewicz, T., Burmeister, A. (2017) *AIM reference track - test site for V2X communication systems and cooperative ITS services*. Journal of Large-Scale Research Facilities JLSRF, 3 (A106). DOI: 10.17815/jlsrf-3-145 ISSN 2364-091X
- [4] MAVEN deliverable 3.1: "Detailed concepts for cooperative manoeuvre and trajectory planning and for in-vehicle cooperative environment perception", December 2018.
- [5] Rondinone, M., Walter, T., Blokpoel, R., Schindler, J. (2018) "V2X Communications for Infrastructure-Assisted Automated Driving," 2018 IEEE 19th International Symposium on "A

- World of Wireless, Mobile and Multimedia Networks" (WoWMoM)*, Chania, 2018, pp. 14-19.doi: 10.1109/WoWMoM.2018.8449775
- [6] ETSI EN 302 637-2 Intelligent Transport Systems (ITS); Vehicular Communications; *Basic Set of Applications; Part 2: Specification of Cooperative Awareness Basic Service*, V1.3.2 (2014-11)
- [7] MAVEN deliverable MAVEN Deliverable 5.1, "V2X communications for infrastructure-assisted automated driving", Feb 2018
- [8] Lorenz, T., Baumann, M., Jaschke, K., Köster, F. (2011) *A Modular and Scalable Application Platform for Testing and Evaluating Its Components*. 20th IEEE International Workshops on Enabling Technologies: Infrastructure for Collaborative Enterprises. IEEE Computer Society Conference Publishing Services (CPS). ISBN 978-0-7695-4410-6.
- [9] MAVEN deliverable 4.1: "Cooperative adaptive traffic light with automated vehicles", January 2018
- [10] Erdmann, J. (2013) *Combining Adaptive Junction Control with Simultaneous Green-Light-Optimal-Speed-Advisory*. WiVeC 2013, 2.-3. June 2013, Dresden, Germany. ISBN 978-1-4673-6335-8