



University of Nebraska - Lincoln

DigitalCommons@University of Nebraska - Lincoln

Architectural Engineering -- Faculty Publications

Architectural Engineering and Construction,
Durham School of

2019

METHOD OF MONITORING CHARGE CONDITION OF HEAT PUMP SYSTEM

Fadi M. Alsaleem

Gregg M. Hemmelgarn

Follow this and additional works at: <https://digitalcommons.unl.edu/archengfacpub>



Part of the [Architectural Engineering Commons](#), [Construction Engineering Commons](#), [Environmental Design Commons](#), and the [Other Engineering Commons](#)

This Article is brought to you for free and open access by the Architectural Engineering and Construction, Durham School of at DigitalCommons@University of Nebraska - Lincoln. It has been accepted for inclusion in Architectural Engineering -- Faculty Publications by an authorized administrator of DigitalCommons@University of Nebraska - Lincoln.



US010443863B2

(12) **United States Patent**
Alsalem et al.

(10) **Patent No.:** **US 10,443,863 B2**
(45) **Date of Patent:** ***Oct. 15, 2019**

(54) **METHOD OF MONITORING CHARGE CONDITION OF HEAT PUMP SYSTEM**

(56) **References Cited**

(71) Applicant: **Emerson Climate Technologies, Inc.**,
Sidney, OH (US)

U.S. PATENT DOCUMENTS
2,054,542 A 9/1936 Hoelle
2,296,822 A 9/1942 Wolfert
(Continued)

(72) Inventors: **Fadi M. Alsalem**, Omaha, NE (US);
Gregg M. Hemmelgarn, Yorkshire, OH (US)

FOREIGN PATENT DOCUMENTS

(73) Assignee: **Emerson Climate Technologies, Inc.**,
Sidney, OH (US)

CA 1147440 A1 5/1983
CA 1151265 A1 8/1983
(Continued)

(*) Notice: Subject to any disclaimer, the term of this patent is extended or adjusted under 35 U.S.C. 154(b) by 0 days.

OTHER PUBLICATIONS

This patent is subject to a terminal disclaimer.

"A Practical Example of a Building's Automatic Control," cited in First Office Action from the Patent Office of the People's Republic of China dated Jun. 29, 2007, regarding Application No. 200510005907.8, including translation by CCPIT Patent and Trademark Law Office.

(21) Appl. No.: **16/113,271**

(22) Filed: **Aug. 27, 2018**

(Continued)

(65) **Prior Publication Data**

US 2018/0363926 A1 Dec. 20, 2018

Related U.S. Application Data

(60) Division of application No. 14/607,782, filed on Jan. 28, 2015, now Pat. No. 10,060,636, which is a (Continued)

(57) **ABSTRACT**

A heat-pump circuit may include an indoor heat exchanger, an outdoor heat exchanger, a compressor adapted to circulate a working fluid between the indoor and outdoor heat exchangers, and an expansion device disposed between the indoor and outdoor heat exchangers. A monitor for the heat-pump system may include a return-air temperature sensor, a supply-air temperature sensor, and a processor. The return-air temperature sensor may be adapted to measure a first air temperature of air upstream of the indoor heat exchanger. The supply-air temperature sensor may be adapted to measure a second air temperature of air downstream of the indoor heat exchanger. The processor may be in communication with the return-air temperature sensor and the supply-air temperature sensor. The processor may be programmed to determine a working-fluid-charge condition (Continued)

(51) **Int. Cl.**
F24D 19/10 (2006.01)
F25B 49/00 (2006.01)
F25B 13/00 (2006.01)

(52) **U.S. Cl.**
CPC **F24D 19/1087** (2013.01); **F25B 49/00** (2013.01); **F25B 49/005** (2013.01); (Continued)

(58) **Field of Classification Search**
CPC F25B 2500/22; F25B 2500/23; F25B 2500/24; F25B 2700/21172; F25B 2700/21173; F25B 2700/04 (Continued)

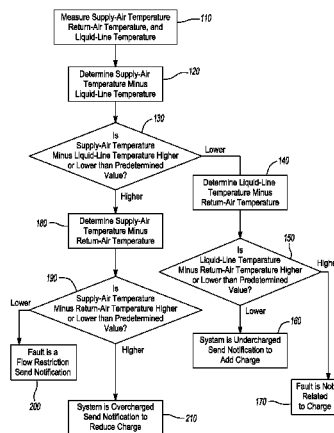

of the heat-pump system based on the first and second air temperatures.

7 Claims, 2 Drawing Sheets

Related U.S. Application Data

continuation of application No. 14/244,967, filed on Apr. 4, 2014, now Pat. No. 9,765,979.

(60) Provisional application No. 61/808,688, filed on Apr. 5, 2013.

(52) **U.S. Cl.**
 CPC **H05K 999/99** (2013.01); *F24D 2220/042* (2013.01); *F25B 13/00* (2013.01); *F25B 2500/22* (2013.01); *F25B 2500/23* (2013.01); *F25B 2500/24* (2013.01); *F25B 2700/2106* (2013.01); *F25B 2700/21161* (2013.01); *F25B 2700/21163* (2013.01); *F25B 2700/21172* (2013.01); *F25B 2700/21173* (2013.01)

(58) **Field of Classification Search**
 USPC 165/11.1, 288-293; 62/126, 129
 See application file for complete search history.

(56) **References Cited**

U.S. PATENT DOCUMENTS

| | | | | | | | |
|-----------|---|---------|----------------|-----------|---|---------|-------------------|
| 2,631,050 | A | 3/1953 | Haerberlein | 4,018,584 | A | 4/1977 | Mullen |
| 2,804,839 | A | 9/1957 | Hallinan | 4,019,172 | A | 4/1977 | Srodes |
| 2,961,606 | A | 11/1960 | Mead | 4,024,725 | A | 5/1977 | Uchida et al. |
| 2,962,702 | A | 11/1960 | Derr et al. | 4,027,289 | A | 5/1977 | Toman |
| 2,978,879 | A | 4/1961 | Heidorn | 4,034,570 | A | 7/1977 | Anderson et al. |
| 3,027,865 | A | 4/1962 | Kautz et al. | 4,038,061 | A | 7/1977 | Anderson et al. |
| 3,047,696 | A | 7/1962 | Heidorn | 4,045,973 | A | 9/1977 | Anderson et al. |
| 3,082,951 | A | 3/1963 | Kayan | 4,046,532 | A | 9/1977 | Nelson |
| 3,107,843 | A | 10/1963 | Finn | RE29,450 | E | 10/1977 | Goldsby et al. |
| 3,170,304 | A | 2/1965 | Hale | 4,060,716 | A | 11/1977 | Pekrul et al. |
| 3,232,519 | A | 2/1966 | Long | 4,066,869 | A | 1/1978 | Apaloo et al. |
| 3,278,111 | A | 10/1966 | Parker | 4,090,248 | A | 5/1978 | Swanson et al. |
| 3,327,197 | A | 6/1967 | Marquis | 4,102,150 | A | 7/1978 | Kountz |
| 3,339,164 | A | 8/1967 | Landis et al. | 4,102,394 | A | 7/1978 | Botts |
| 3,400,374 | A | 9/1968 | Schumann | 4,104,888 | A | 8/1978 | Reedy et al. |
| 3,513,662 | A | 5/1970 | Golber | 4,105,063 | A | 8/1978 | Bergt |
| 3,581,281 | A | 5/1971 | Martin et al. | 4,112,703 | A | 9/1978 | Kountz |
| 3,585,451 | A | 6/1971 | Day, III | 4,132,086 | A | 1/1979 | Kountz |
| 3,653,783 | A | 4/1972 | Sauder | 4,136,730 | A | 1/1979 | Kinsey |
| 3,660,718 | A | 5/1972 | Pinckaers | 4,137,057 | A | 1/1979 | Piet et al. |
| 3,665,339 | A | 5/1972 | Liu | 4,137,725 | A | 2/1979 | Martin |
| 3,665,399 | A | 5/1972 | Zehr et al. | 4,142,375 | A | 3/1979 | Abe et al. |
| 3,680,324 | A | 8/1972 | Garland | 4,143,707 | A | 3/1979 | Lewis et al. |
| 3,697,953 | A | 10/1972 | Schoenwitz | 4,146,085 | A | 3/1979 | Wills |
| 3,707,851 | A | 1/1973 | McAshan, Jr. | RE29,966 | E | 4/1979 | Nussbaum |
| 3,729,949 | A | 5/1973 | Talbot | 4,151,725 | A | 5/1979 | Kountz et al. |
| 3,735,377 | A | 5/1973 | Kaufman | 4,153,003 | A | 5/1979 | Willis |
| 3,742,302 | A | 6/1973 | Neill | 4,156,350 | A | 5/1979 | Elliott et al. |
| 3,742,303 | A | 6/1973 | Dageford | 4,161,106 | A | 7/1979 | Savage et al. |
| 3,767,328 | A | 10/1973 | Ladusaw | 4,165,619 | A | 8/1979 | Girard |
| 3,777,240 | A | 12/1973 | Neill | 4,171,622 | A | 10/1979 | Yamaguchi et al. |
| 3,783,681 | A | 1/1974 | Hirt et al. | 4,173,871 | A | 11/1979 | Brooks |
| 3,820,074 | A | 6/1974 | Toman | 4,178,988 | A | 12/1979 | Cann et al. |
| 3,882,305 | A | 5/1975 | Johnstone | RE30,242 | E | 4/1980 | del Toro et al. |
| 3,924,972 | A | 12/1975 | Szymaszek | 4,197,717 | A | 4/1980 | Schumacher |
| 3,927,712 | A | 12/1975 | Nakayama | 4,205,381 | A | 5/1980 | Games et al. |
| 3,935,519 | A | 1/1976 | Pfarrer et al. | 4,209,994 | A | 7/1980 | Mueller et al. |
| 3,950,962 | A | 4/1976 | Odashima | 4,211,089 | A | 7/1980 | Mueller et al. |
| 3,960,011 | A | 6/1976 | Renz et al. | 4,217,761 | A | 8/1980 | Cornaire et al. |
| 3,978,382 | A | 8/1976 | Pfarrer et al. | 4,220,010 | A | 9/1980 | Mueller et al. |
| 3,998,068 | A | 12/1976 | Chirnside | 4,227,862 | A | 10/1980 | Andrew et al. |
| 4,006,460 | A | 2/1977 | Hewitt et al. | 4,232,530 | A | 11/1980 | Mueller |
| 4,014,182 | A | 3/1977 | Granryd | 4,233,818 | A | 11/1980 | Lastinger |
| | | | | 4,236,379 | A | 12/1980 | Mueller |
| | | | | 4,244,182 | A | 1/1981 | Behr |
| | | | | 4,246,763 | A | 1/1981 | Mueller et al. |
| | | | | 4,248,051 | A | 2/1981 | Darcy et al. |
| | | | | 4,251,988 | A | 2/1981 | Allard et al. |
| | | | | 4,257,795 | A | 3/1981 | Shaw |
| | | | | 4,259,847 | A | 4/1981 | Pearse, Jr. |
| | | | | 4,267,702 | A | 5/1981 | Houk |
| | | | | 4,270,174 | A | 5/1981 | Karlin et al. |
| | | | | 4,271,898 | A | 6/1981 | Freeman |
| | | | | 4,281,358 | A | 7/1981 | Plouffe et al. |
| | | | | 4,284,849 | A | 8/1981 | Anderson et al. |
| | | | | 4,286,438 | A | 9/1981 | Clarke |
| | | | | 4,290,480 | A | 9/1981 | Sulkowski |
| | | | | 4,296,727 | A | 10/1981 | Bryan |
| | | | | 4,301,660 | A | 11/1981 | Mueller et al. |
| | | | | 4,306,293 | A | 12/1981 | Marathe |
| | | | | 4,307,775 | A | 12/1981 | Saunders et al. |
| | | | | 4,308,725 | A | 1/1982 | Chiyoda |
| | | | | 4,311,188 | A | 1/1982 | Kojima et al. |
| | | | | 4,319,461 | A | 3/1982 | Shaw |
| | | | | 4,321,529 | A | 3/1982 | Simmonds et al. |
| | | | | 4,325,223 | A | 4/1982 | Cantley |
| | | | | 4,328,678 | A | 5/1982 | Kono et al. |
| | | | | 4,328,680 | A | 5/1982 | Stamp, Jr. et al. |
| | | | | 4,333,316 | A | 6/1982 | Stamp, Jr. et al. |
| | | | | 4,333,317 | A | 6/1982 | Sawyer |
| | | | | 4,336,001 | A | 6/1982 | Andrew et al. |
| | | | | 4,338,790 | A | 7/1982 | Saunders et al. |
| | | | | 4,338,791 | A | 7/1982 | Stamp, Jr. et al. |
| | | | | 4,345,162 | A | 8/1982 | Hammer et al. |
| | | | | 4,346,755 | A | 8/1982 | Alley et al. |
| | | | | 4,350,021 | A | 9/1982 | Lundstrom |
| | | | | 4,350,023 | A | 9/1982 | Kuwabara et al. |
| | | | | 4,351,163 | A | 9/1982 | Johannsen |
| | | | | 4,356,703 | A | 11/1982 | Vogel |

(56)

References Cited

U.S. PATENT DOCUMENTS

| | | | | | | | |
|-----------|---|-----------|---------------------------------------|-----------|---|---------|-------------------------|
| 4,361,273 | A | 11/1982 | Levine et al. | 4,539,820 | A | 9/1985 | Zinsmeyer |
| 4,365,983 | A | 12/1982 | Abraham et al. | 4,540,040 | A | 9/1985 | Fukumoto et al. |
| 4,370,098 | A | 1/1983 | McClain et al. | 4,545,210 | A | 10/1985 | Lord |
| 4,372,119 | A | 2/1983 | Gillbrand et al. | 4,545,214 | A | 10/1985 | Kinoshita |
| 4,376,926 | A | 3/1983 | Senor | 4,548,549 | A | 10/1985 | Murphy et al. |
| 4,381,549 | A | 4/1983 | Stamp, Jr. et al. | 4,549,403 | A | 10/1985 | Lord et al. |
| 4,382,367 | A | 5/1983 | Roberts | 4,549,404 | A | 10/1985 | Lord |
| 4,384,462 | A | 5/1983 | Overman et al. | 4,550,770 | A | 11/1985 | Nussdorfer et al. |
| 4,387,368 | A | 6/1983 | Day, III et al. | 4,553,400 | A | 11/1985 | Branz |
| 4,387,578 | A | 6/1983 | Paddock | 4,555,057 | A | 11/1985 | Foster |
| 4,390,058 | A | 6/1983 | Otake et al. | 4,555,910 | A | 12/1985 | Sturges |
| 4,390,321 | A | 6/1983 | Langlois et al. | 4,557,317 | A | 12/1985 | Harmon, Jr. |
| 4,390,922 | A | 6/1983 | Pelliccia | 4,558,181 | A | 12/1985 | Blanchard et al. |
| 4,395,886 | A | 8/1983 | Mayer | 4,561,260 | A | 12/1985 | Nishi et al. |
| 4,395,887 | A | 8/1983 | Sweetman | 4,563,624 | A | 1/1986 | Yu |
| 4,399,548 | A | 8/1983 | Castleberry | 4,563,877 | A | 1/1986 | Harnish |
| 4,402,054 | A | 8/1983 | Osborne et al. | 4,563,878 | A | 1/1986 | Baglione |
| 4,406,133 | A | 9/1983 | Saunders et al. | 4,567,733 | A | 2/1986 | Mecozzi |
| 4,407,138 | A | 10/1983 | Mueller | 4,568,909 | A | 2/1986 | Whynacht |
| 4,408,660 | A | 10/1983 | Sutou et al. | 4,574,871 | A | 3/1986 | Parkinson et al. |
| 4,412,788 | A | 11/1983 | Shaw et al. | 4,575,318 | A | 3/1986 | Blain |
| 4,415,896 | A | 11/1983 | Allgood | 4,577,977 | A | 3/1986 | Pejsa |
| 4,418,388 | A | 11/1983 | Allgor et al. | 4,580,947 | A | 4/1986 | Shibata et al. |
| 4,420,947 | A | 12/1983 | Yoshino | 4,583,373 | A | 4/1986 | Shaw |
| 4,425,010 | A | 1/1984 | Bryant et al. | 4,589,060 | A | 5/1986 | Zinsmeyer |
| 4,429,578 | A | 2/1984 | Darrel et al. | 4,593,367 | A | 6/1986 | Slack et al. |
| 4,432,232 | A | 2/1984 | Brantley et al. | 4,598,764 | A | 7/1986 | Beckey |
| 4,434,390 | A | 2/1984 | Elms | 4,602,484 | A | 7/1986 | Bendikson |
| 4,441,329 | A | 4/1984 | Dawley | 4,603,556 | A | 8/1986 | Suefuji et al. |
| 4,448,038 | A | 5/1984 | Barbier | 4,604,036 | A | 8/1986 | Sutou et al. |
| 4,449,375 | A | 5/1984 | Briccetti | 4,611,470 | A | 9/1986 | Enstrom |
| 4,451,929 | A | 5/1984 | Yoshida | 4,612,775 | A | 9/1986 | Branz et al. |
| 4,460,123 | A | 7/1984 | Beverly | 4,614,089 | A | 9/1986 | Dorsey |
| 4,463,571 | A | 8/1984 | Wiggs | 4,617,804 | A | 10/1986 | Fukushima et al. |
| 4,463,574 | A | 8/1984 | Spethmann et al. | 4,620,286 | A | 10/1986 | Smith et al. |
| 4,463,576 | A | 8/1984 | Burnett et al. | 4,620,424 | A | 11/1986 | Tanaka et al. |
| 4,465,229 | A | 8/1984 | Kompelien | 4,621,502 | A | 11/1986 | Ibrahim et al. |
| 4,467,230 | A | 8/1984 | Rovinsky | 4,626,753 | A | 12/1986 | Letterman |
| 4,467,385 | A | 8/1984 | Bandoli et al. | 4,627,245 | A | 12/1986 | Levine |
| 4,467,613 | A | 8/1984 | Behr et al. | 4,627,483 | A | 12/1986 | Harshbarger, III et al. |
| 4,470,092 | A | 9/1984 | Lombardi | 4,627,484 | A | 12/1986 | Harshbarger, Jr. et al. |
| 4,470,266 | A | 9/1984 | Briccetti et al. | 4,630,572 | A | 12/1986 | Evans |
| 4,474,024 | A | 10/1984 | Eplett et al. | 4,630,670 | A | 12/1986 | Wellman et al. |
| 4,474,542 | A | 10/1984 | Kato et al. | 4,642,034 | A | 2/1987 | Terauchi |
| 4,479,389 | A | 10/1984 | Anderson, III et al. | 4,642,782 | A | 2/1987 | Kemper et al. |
| 4,484,452 | A | * 11/1984 | Houser, Jr. F25B 13/00 62/149 | 4,644,479 | A | 2/1987 | Kemper et al. |
| 4,489,551 | A | 12/1984 | Watanabe et al. | 4,646,532 | A | 3/1987 | Nose |
| 4,490,986 | A | 1/1985 | Paddock | 4,648,044 | A | 3/1987 | Hardy et al. |
| 4,494,383 | A | 1/1985 | Nagatomo et al. | 4,649,515 | A | 3/1987 | Thompson et al. |
| 4,495,779 | A | 1/1985 | Tanaka et al. | 4,649,710 | A | 3/1987 | Inoue et al. |
| 4,496,296 | A | 1/1985 | Arai et al. | 4,653,280 | A | 3/1987 | Hansen et al. |
| 4,497,031 | A | 1/1985 | Froehling et al. | 4,653,285 | A | 3/1987 | Pohl |
| 4,498,310 | A | 2/1985 | Lmanishi et al. | 4,655,688 | A | 4/1987 | Bohn et al. |
| 4,499,739 | A | 2/1985 | Matsuoka et al. | 4,660,386 | A | 4/1987 | Hansen et al. |
| 4,502,084 | A | 2/1985 | Hannett | 4,662,184 | A | 5/1987 | Pohl et al. |
| 4,502,833 | A | 3/1985 | Hibino et al. | 4,674,292 | A | 6/1987 | Ohya et al. |
| 4,502,842 | A | 3/1985 | Currier et al. | 4,677,830 | A | 7/1987 | Sumikawa et al. |
| 4,502,843 | A | 3/1985 | Martin | 4,680,940 | A | 7/1987 | Vaughn |
| 4,505,125 | A | 3/1985 | Baglione | 4,682,473 | A | 7/1987 | Rogers, III |
| 4,506,518 | A | 3/1985 | Yoshikawa et al. | 4,684,060 | A | 8/1987 | Adams et al. |
| 4,507,934 | A | 4/1985 | Tanaka et al. | 4,685,615 | A | 8/1987 | Hart |
| 4,510,547 | A | 4/1985 | Rudich, Jr. | 4,686,835 | A | 8/1987 | Alsenz |
| 4,510,576 | A | 4/1985 | MacArthur et al. | 4,689,967 | A | 9/1987 | Han et al. |
| 4,512,161 | A | 4/1985 | Logan et al. | 4,697,431 | A | 10/1987 | Alsenz |
| 4,516,407 | A | 5/1985 | Watabe | 4,698,978 | A | 10/1987 | Jones |
| 4,517,468 | A | 5/1985 | Kemper et al. | 4,698,981 | A | 10/1987 | Kaneko et al. |
| 4,520,674 | A | 6/1985 | Canada et al. | 4,701,824 | A | 10/1987 | Beggs et al. |
| 4,523,435 | A | 6/1985 | Lord | 4,703,325 | A | 10/1987 | Chamberlin et al. |
| 4,523,436 | A | 6/1985 | Schedel et al. | 4,706,152 | A | 11/1987 | DeFilippis et al. |
| 4,527,247 | A | 7/1985 | Kaiser et al. | 4,706,469 | A | 11/1987 | Oguni et al. |
| 4,527,399 | A | 7/1985 | Lord | 4,712,648 | A | 12/1987 | Mattes et al. |
| 4,535,607 | A | 8/1985 | Mount | 4,713,717 | A | 12/1987 | Pejouhy et al. |
| 4,538,420 | A | 9/1985 | Nelson | 4,715,190 | A | 12/1987 | Han et al. |
| 4,538,422 | A | 9/1985 | Mount et al. | 4,715,792 | A | 12/1987 | Nishizawa et al. |
| | | | | 4,716,582 | A | 12/1987 | Blanchard et al. |
| | | | | 4,716,957 | A | 1/1988 | Thompson et al. |
| | | | | 4,720,980 | A | 1/1988 | Howland |
| | | | | 4,722,018 | A | 1/1988 | Pohl |
| | | | | 4,722,019 | A | 1/1988 | Pohl |

(56)

References Cited

U.S. PATENT DOCUMENTS

| | | | | | | | |
|-----------|---|---------|----------------------|-----------|---|---------|--------------------|
| 4,724,678 | A | 2/1988 | Pohl | 4,928,750 | A | 5/1990 | Nurczyk |
| 4,735,054 | A | 4/1988 | Beckey | 4,932,588 | A | 6/1990 | Fedter et al. |
| 4,735,060 | A | 4/1988 | Alsenz | 4,939,909 | A | 7/1990 | Tsuchiyama et al. |
| 4,744,223 | A | 5/1988 | Umezū | 4,943,003 | A | 7/1990 | Shimizu et al. |
| 4,745,765 | A | 5/1988 | Pettitt | 4,944,160 | A | 7/1990 | Malone et al. |
| 4,745,766 | A | 5/1988 | Bahr | 4,945,491 | A | 7/1990 | Rishel |
| 4,745,767 | A | 5/1988 | Ohya et al. | 4,948,040 | A | 8/1990 | Kobayashi et al. |
| 4,750,332 | A | 6/1988 | Jenski et al. | 4,949,550 | A | 8/1990 | Hanson |
| 4,750,672 | A | 6/1988 | Beckey et al. | 4,953,784 | A | 9/1990 | Yasufuku et al. |
| 4,751,501 | A | 6/1988 | Gut | 4,959,970 | A | 10/1990 | Meckler |
| 4,751,825 | A | 6/1988 | Voorhis et al. | 4,964,060 | A | 10/1990 | Hartsog |
| 4,754,410 | A | 6/1988 | Leech et al. | 4,964,125 | A | 10/1990 | Kim |
| 4,755,957 | A | 7/1988 | White et al. | 4,966,006 | A | 10/1990 | Thuesen et al. |
| 4,765,150 | A | 8/1988 | Persem | 4,967,567 | A | 11/1990 | Proctor et al. |
| 4,768,346 | A | 9/1988 | Mathur | 4,970,496 | A | 11/1990 | Kirkpatrick |
| 4,768,348 | A | 9/1988 | Noguchi | 4,974,427 | A | 12/1990 | Diab |
| 4,783,752 | A | 11/1988 | Kaplan et al. | 4,974,665 | A | 12/1990 | Zillner, Jr. |
| 4,787,213 | A | 11/1988 | Gras et al. | 4,975,024 | A | 12/1990 | Heckel |
| 4,790,142 | A | 12/1988 | Beckey | 4,977,751 | A | 12/1990 | Hanson |
| 4,796,142 | A | 1/1989 | Libert | 4,985,857 | A | 1/1991 | Bajpai et al. |
| 4,796,466 | A | 1/1989 | Farmer | 4,987,748 | A | 1/1991 | Meckler |
| 4,798,055 | A | 1/1989 | Murray et al. | 4,990,057 | A | 2/1991 | Rollins |
| 4,805,118 | A | 2/1989 | Rishel | 4,990,893 | A | 2/1991 | Kiluk |
| 4,807,445 | A | 2/1989 | Matsuoka et al. | 4,991,770 | A | 2/1991 | Bird et al. |
| 4,820,130 | A | 4/1989 | Eber et al. | 5,000,009 | A | 3/1991 | Clanin |
| 4,829,779 | A | 5/1989 | Munson et al. | 5,005,365 | A | 4/1991 | Lynch |
| 4,831,560 | A | 5/1989 | Zaleski | 5,009,074 | A | 4/1991 | Goubeaux et al. |
| 4,831,832 | A | 5/1989 | Alsenz | 5,009,075 | A | 4/1991 | Okoren |
| 4,831,833 | A | 5/1989 | Duenes et al. | 5,009,076 | A | 4/1991 | Winslow |
| 4,835,706 | A | 5/1989 | Asahi | 5,012,629 | A | 5/1991 | Rehman et al. |
| 4,835,980 | A | 6/1989 | Oyanagi et al. | 5,018,357 | A | 5/1991 | Livingstone et al. |
| 4,838,037 | A | 6/1989 | Wood | 5,018,665 | A | 5/1991 | Sulmone |
| 4,841,734 | A | 6/1989 | Torrence | RE33,620 | E | 6/1991 | Persem |
| 4,843,575 | A | 6/1989 | Crane | 5,022,234 | A | 6/1991 | Goubeaux et al. |
| 4,845,956 | A | 7/1989 | Berntsen et al. | 5,039,009 | A | 8/1991 | Baldwin et al. |
| 4,848,099 | A | 7/1989 | Beckey et al. | 5,042,264 | A | 8/1991 | Dudley |
| 4,848,100 | A | 7/1989 | Barthel et al. | 5,051,720 | A | 9/1991 | Kittirutsunetorn |
| 4,850,198 | A | 7/1989 | Helt et al. | 5,054,294 | A | 10/1991 | Dudley |
| 4,850,204 | A | 7/1989 | Bos et al. | 5,056,036 | A | 10/1991 | Van Bork |
| 4,852,363 | A | 8/1989 | Kampf et al. | 5,056,329 | A | 10/1991 | Wilkinson |
| 4,853,693 | A | 8/1989 | Eaton-Williams | 5,058,388 | A | 10/1991 | Shaw et al. |
| 4,856,286 | A | 8/1989 | Sulfstede et al. | 5,062,278 | A | 11/1991 | Sugiyama |
| 4,858,676 | A | 8/1989 | Bolfik et al. | 5,065,593 | A | 11/1991 | Dudley et al. |
| 4,866,635 | A | 9/1989 | Kahn et al. | 5,067,099 | A | 11/1991 | McCown et al. |
| 4,866,944 | A | 9/1989 | Yamazaki | RE33,775 | E | 12/1991 | Behr et al. |
| 4,869,073 | A | 9/1989 | Kawai et al. | 5,070,468 | A | 12/1991 | Niinomi et al. |
| 4,873,836 | A | 10/1989 | Thompson | 5,071,065 | A | 12/1991 | Aalto et al. |
| 4,875,589 | A | 10/1989 | Lacey et al. | 5,073,091 | A | 12/1991 | Burgess et al. |
| 4,877,382 | A | 10/1989 | Caillat et al. | 5,073,862 | A | 12/1991 | Carlson |
| 4,878,355 | A | 11/1989 | Beckey et al. | 5,076,067 | A | 12/1991 | Prenger et al. |
| 4,881,184 | A | 11/1989 | Abegg, III et al. | 5,076,494 | A | 12/1991 | Ripka |
| 4,882,747 | A | 11/1989 | Williams | 5,077,983 | A | 1/1992 | Dudley |
| 4,882,908 | A | 11/1989 | White | 5,083,438 | A | 1/1992 | McMullin |
| 4,884,412 | A | 12/1989 | Sellers et al. | 5,086,385 | A | 2/1992 | Launey et al. |
| 4,885,707 | A | 12/1989 | Nichol et al. | 5,088,297 | A | 2/1992 | Maruyama et al. |
| 4,885,914 | A | 12/1989 | Pearman | 5,094,086 | A | 3/1992 | Shyu |
| 4,887,436 | A | 12/1989 | Enomoto et al. | 5,095,712 | A | 3/1992 | Narreau |
| 4,887,857 | A | 12/1989 | VanOmmeren | 5,095,715 | A | 3/1992 | Dudley |
| 4,889,280 | A | 12/1989 | Grald et al. | 5,099,654 | A | 3/1992 | Baruschke et al. |
| 4,893,480 | A | 1/1990 | Matsui et al. | 5,102,316 | A | 4/1992 | Caillat et al. |
| 4,899,551 | A | 2/1990 | Weintraub | 5,103,391 | A | 4/1992 | Barrett |
| 4,903,500 | A | 2/1990 | Hanson | 5,107,500 | A | 4/1992 | Wakamoto et al. |
| 4,903,759 | A | 2/1990 | Lapeyrouse | 5,109,222 | A | 4/1992 | Welty |
| 4,904,993 | A | 2/1990 | Sato | 5,109,676 | A | 5/1992 | Waters et al. |
| 4,909,041 | A | 3/1990 | Jones | 5,109,700 | A | 5/1992 | Hicho |
| 4,909,076 | A | 3/1990 | Busch et al. | 5,109,916 | A | 5/1992 | Thompson |
| 4,910,966 | A | 3/1990 | Levine et al. | 5,115,406 | A | 5/1992 | Zatezalo et al. |
| 4,913,625 | A | 4/1990 | Gerlowski | 5,115,643 | A | 5/1992 | Hayata et al. |
| 4,916,633 | A | 4/1990 | Tychonievich et al. | 5,115,644 | A | 5/1992 | Alsenz |
| 4,916,909 | A | 4/1990 | Mathur et al. | 5,115,967 | A | 5/1992 | Wedekind |
| 4,916,912 | A | 4/1990 | Levine et al. | 5,118,260 | A | 6/1992 | Fraser, Jr. |
| 4,918,690 | A | 4/1990 | Markkula, Jr. et al. | 5,119,466 | A | 6/1992 | Suzuki |
| 4,918,932 | A | 4/1990 | Gustafson et al. | 5,119,637 | A | 6/1992 | Bard et al. |
| 4,924,404 | A | 5/1990 | Reinke, Jr. | 5,121,610 | A | 6/1992 | Atkinson et al. |
| 4,924,418 | A | 5/1990 | Bachman et al. | 5,123,017 | A | 6/1992 | Simpkins et al. |
| | | | | 5,123,252 | A | 6/1992 | Hanson |
| | | | | 5,123,253 | A | 6/1992 | Hanson et al. |
| | | | | 5,123,255 | A | 6/1992 | Ohizumi |
| | | | | 5,125,067 | A | 6/1992 | Erdman |

(56)

References Cited

U.S. PATENT DOCUMENTS

| | | | | | |
|-------------|---------|--------------------|-------------|---------|---------------------|
| RE34,001 E | 7/1992 | Wrobel | 5,381,669 A | 1/1995 | Bahel et al. |
| 5,127,232 A | 7/1992 | Paige et al. | 5,381,692 A | 1/1995 | Winslow et al. |
| 5,131,237 A | 7/1992 | Valbjorn | 5,388,176 A | 2/1995 | Dykstra et al. |
| 5,136,855 A | 8/1992 | Lenarduzzi | 5,395,042 A | 3/1995 | Riley et al. |
| 5,140,394 A | 8/1992 | Cobb, III et al. | 5,410,230 A | 4/1995 | Bessler et al. |
| 5,141,407 A | 8/1992 | Ramsey et al. | 5,414,792 A | 5/1995 | Shorey |
| 5,142,877 A | 9/1992 | Shimizu | 5,415,008 A | 5/1995 | Bessler |
| 5,150,584 A | 9/1992 | Tomasov et al. | 5,416,781 A | 5/1995 | Ruiz |
| 5,156,539 A | 10/1992 | Anderson et al. | 5,423,190 A | 6/1995 | Friedland |
| 5,167,494 A | 12/1992 | Inagaki et al. | 5,423,192 A | 6/1995 | Young et al. |
| 5,170,935 A | 12/1992 | Federspiel et al. | 5,426,952 A | 6/1995 | Bessler |
| 5,170,936 A | 12/1992 | Kubo et al. | 5,431,026 A | 7/1995 | Jaster |
| 5,181,389 A | 1/1993 | Hanson et al. | 5,432,500 A | 7/1995 | Scripps |
| 5,186,014 A | 2/1993 | Runk | 5,435,145 A | 7/1995 | Jaster |
| 5,197,666 A | 3/1993 | Wedekind | 5,435,148 A | 7/1995 | Sandofsky et al. |
| 5,199,855 A | 4/1993 | Nakajima et al. | 5,440,890 A | 8/1995 | Bahel et al. |
| 5,200,872 A | 4/1993 | D'Entremont et al. | 5,440,891 A | 8/1995 | Hindmon, Jr. et al. |
| 5,200,987 A | 4/1993 | Gray | 5,440,895 A | 8/1995 | Bahel et al. |
| 5,201,862 A | 4/1993 | Pettitt | 5,446,677 A | 8/1995 | Jensen et al. |
| 5,203,178 A | 4/1993 | Shyu | 5,450,359 A | 9/1995 | Sharma et al. |
| 5,203,179 A | 4/1993 | Powell | 5,452,291 A | 9/1995 | Eisenhandler et al. |
| 5,209,076 A | 5/1993 | Kauffman et al. | 5,454,229 A | 10/1995 | Hanson et al. |
| 5,209,400 A | 5/1993 | Winslow et al. | 5,457,965 A | 10/1995 | Blair et al. |
| 5,219,041 A | 6/1993 | Greve | 5,460,006 A | 10/1995 | Torimitsu |
| 5,224,354 A | 7/1993 | Ito et al. | 5,467,011 A | 11/1995 | Hunt |
| 5,224,835 A | 7/1993 | Oltman | 5,467,264 A | 11/1995 | Rauch et al. |
| 5,226,472 A | 7/1993 | Benevelli et al. | 5,469,045 A | 11/1995 | Dove et al. |
| 5,228,300 A | 7/1993 | Shim | 5,475,986 A | 12/1995 | Bahel et al. |
| 5,228,304 A | 7/1993 | Ryan | 5,478,212 A | 12/1995 | Sakai et al. |
| 5,228,307 A | 7/1993 | Koce | 5,481,481 A | 1/1996 | Frey et al. |
| 5,230,223 A | 7/1993 | Hullar et al. | 5,481,884 A | 1/1996 | Scoccia |
| 5,231,844 A | 8/1993 | Park | 5,483,141 A | 1/1996 | Uesugi |
| 5,233,841 A | 8/1993 | Jyrek | 5,491,978 A | 2/1996 | Young et al. |
| 5,235,526 A | 8/1993 | Saffell | 5,495,722 A | 3/1996 | Manson et al. |
| 5,237,830 A | 8/1993 | Grant | 5,499,512 A | 3/1996 | Jurewicz et al. |
| 5,241,664 A | 8/1993 | Ohba et al. | 5,509,786 A | 4/1996 | Mizutani et al. |
| 5,241,833 A | 9/1993 | Ohkoshi | 5,511,387 A | 4/1996 | Tinsler |
| 5,243,827 A | 9/1993 | Hagita et al. | 5,512,883 A | 4/1996 | Lane, Jr. |
| 5,243,829 A | 9/1993 | Bessler | 5,515,267 A | 5/1996 | Alsenz |
| 5,245,833 A | 9/1993 | Mei et al. | 5,515,692 A | 5/1996 | Sterber et al. |
| 5,248,244 A | 9/1993 | Ho et al. | 5,519,301 A | 5/1996 | Yoshida et al. |
| 5,251,453 A | 10/1993 | Stanke et al. | 5,519,337 A | 5/1996 | Casada |
| 5,251,454 A | 10/1993 | Yoon | 5,528,908 A | 6/1996 | Bahel et al. |
| 5,255,977 A | 10/1993 | Eimer et al. | 5,532,534 A | 7/1996 | Baker et al. |
| 5,257,506 A | 11/1993 | DeWolf et al. | 5,533,347 A | 7/1996 | Ott et al. |
| 5,262,704 A | 11/1993 | Farr | 5,535,136 A | 7/1996 | Standifer |
| 5,265,434 A | 11/1993 | Alsenz | 5,535,597 A | 7/1996 | An |
| 5,269,458 A | 12/1993 | Sol | 5,546,015 A | 8/1996 | Okabe |
| 5,271,556 A | 12/1993 | Helt et al. | 5,546,073 A | 8/1996 | Duff et al. |
| 5,274,571 A | 12/1993 | Hesse et al. | 5,546,756 A | 8/1996 | Ali |
| 5,276,630 A | 1/1994 | Baldwin et al. | 5,546,757 A | 8/1996 | Whipple, III |
| 5,279,458 A | 1/1994 | DeWolf et al. | 5,548,966 A | 8/1996 | Tinsler |
| 5,282,728 A | 2/1994 | Swain | 5,555,195 A | 9/1996 | Jensen et al. |
| 5,284,026 A | 2/1994 | Powell | 5,562,426 A | 10/1996 | Watanabe et al. |
| 5,285,646 A | 2/1994 | TaeDuk | 5,563,490 A | 10/1996 | Kawaguchi et al. |
| 5,289,362 A | 2/1994 | Liebl et al. | 5,564,280 A | 10/1996 | Schilling et al. |
| 5,290,154 A | 3/1994 | Kotlarek et al. | 5,566,084 A | 10/1996 | Cmar |
| 5,291,752 A | 3/1994 | Alvarez et al. | 5,570,085 A | 10/1996 | Bertsch |
| 5,299,504 A | 4/1994 | Abele | 5,570,258 A | 10/1996 | Manning |
| 5,303,112 A | 4/1994 | Zulaski et al. | 5,572,643 A | 11/1996 | Judson |
| 5,303,560 A | 4/1994 | Hanson et al. | 5,577,905 A | 11/1996 | Momber et al. |
| 5,311,451 A | 5/1994 | Barrett | 5,579,648 A | 12/1996 | Hanson et al. |
| 5,311,562 A | 5/1994 | Palusamy et al. | 5,581,229 A | 12/1996 | Hunt |
| 5,316,448 A | 5/1994 | Ziegler et al. | 5,586,445 A | 12/1996 | Bessler |
| 5,320,506 A | 6/1994 | Fogt | 5,586,446 A | 12/1996 | Torimitsu |
| 5,333,460 A | 8/1994 | Lewis et al. | 5,590,830 A | 1/1997 | Kettler et al. |
| 5,335,507 A | 8/1994 | Powell | 5,592,058 A | 1/1997 | Archer et al. |
| 5,336,058 A | 8/1994 | Yokoyama | 5,592,824 A | 1/1997 | Sogabe et al. |
| 5,337,576 A | 8/1994 | Dorfman et al. | 5,596,507 A | 1/1997 | Jones et al. |
| 5,347,476 A | 9/1994 | McBean, Sr. | 5,600,960 A | 2/1997 | Schwedler et al. |
| 5,351,037 A | 9/1994 | Martell et al. | 5,602,749 A | 2/1997 | Vosburgh |
| 5,362,206 A | 11/1994 | Westerman et al. | 5,602,757 A | 2/1997 | Haseley et al. |
| 5,362,211 A | 11/1994 | Iizuka et al. | 5,602,761 A | 2/1997 | Spoerre et al. |
| 5,368,446 A | 11/1994 | Rode | 5,610,339 A | 3/1997 | Haseley et al. |
| 5,369,958 A | 12/1994 | Kasai et al. | 5,611,674 A | 3/1997 | Bass et al. |
| | | | 5,613,841 A | 3/1997 | Bass et al. |
| | | | 5,615,071 A | 3/1997 | Higashikata et al. |
| | | | 5,616,829 A | 4/1997 | Balaschak et al. |
| | | | 5,623,834 A | 4/1997 | Bahel et al. |

(56)

References Cited

U.S. PATENT DOCUMENTS

| | | | | | | | |
|-----------|---|----------|-----------------------------------|-----------|---|---------|-----------------------|
| 5,628,201 | A | 5/1997 | Bahel et al. | 5,926,103 | A | 7/1999 | Petite |
| 5,630,325 | A | 5/1997 | Bahel et al. | 5,926,531 | A | 7/1999 | Petite |
| 5,635,896 | A | 6/1997 | Tinsley et al. | 5,930,773 | A | 7/1999 | Crooks et al. |
| 5,641,270 | A | 6/1997 | Sgourakes et al. | 5,934,087 | A | 8/1999 | Watanabe et al. |
| 5,643,482 | A | 7/1997 | Sandelman et al. | 5,939,974 | A | 8/1999 | Heagle et al. |
| 5,650,936 | A | 7/1997 | Loucks et al. | 5,946,922 | A | 9/1999 | Viard et al. |
| 5,651,263 | A | * 7/1997 | Nonaka F25B 9/006 62/205 | 5,947,693 | A | 9/1999 | Yang |
| 5,655,379 | A | 8/1997 | Jaster et al. | 5,947,701 | A | 9/1999 | Hugenroth |
| 5,655,380 | A | 8/1997 | Calton | 5,949,677 | A | 9/1999 | Ho |
| 5,656,765 | A | 8/1997 | Gray | 5,950,443 | A | 9/1999 | Meyer et al. |
| 5,656,767 | A | 8/1997 | Garvey, III et al. | 5,953,490 | A | 9/1999 | Wiklund et al. |
| 5,666,815 | A | 9/1997 | Aloise | 5,956,658 | A | 9/1999 | McMahon |
| 5,682,949 | A | 11/1997 | Ratcliffe et al. | 5,971,712 | A | 10/1999 | Kann |
| 5,684,463 | A | 11/1997 | Diercks et al. | 5,975,854 | A | 11/1999 | Culp, III et al. |
| 5,689,963 | A | 11/1997 | Bahel et al. | 5,984,645 | A | 11/1999 | Cummings |
| 5,691,692 | A | 11/1997 | Herbstritt | 5,986,571 | A | 11/1999 | Flick |
| 5,694,010 | A | 12/1997 | Oomura et al. | 5,987,903 | A | 11/1999 | Bathla |
| 5,696,501 | A | 12/1997 | Ouellette et al. | 5,988,986 | A | 11/1999 | Brinken et al. |
| 5,699,670 | A | 12/1997 | Jurewicz et al. | 5,995,347 | A | 11/1999 | Rudd et al. |
| 5,706,007 | A | 1/1998 | Fragnito et al. | 5,995,351 | A | 11/1999 | Katsumata et al. |
| 5,707,210 | A | 1/1998 | Ramsey et al. | 6,006,142 | A | 12/1999 | Seem et al. |
| 5,711,785 | A | 1/1998 | Maxwell | 6,006,171 | A | 12/1999 | Vines et al. |
| 5,713,724 | A | 2/1998 | Centers et al. | 6,011,368 | A | 1/2000 | Kalpathi et al. |
| 5,714,931 | A | 2/1998 | Petite et al. | 6,013,108 | A | 1/2000 | Karolys et al. |
| 5,715,704 | A | 2/1998 | Cholkeri et al. | 6,017,192 | A | 1/2000 | Clack et al. |
| 5,718,822 | A | 2/1998 | Richter | 6,020,702 | A | 2/2000 | Farr |
| 5,724,571 | A | 3/1998 | Woods | 6,023,420 | A | 2/2000 | McCormick et al. |
| 5,729,474 | A | 3/1998 | Hildebrand et al. | 6,026,651 | A | 2/2000 | Sandelman |
| 5,737,931 | A | 4/1998 | Ueno et al. | 6,028,522 | A | 2/2000 | Petite |
| 5,741,120 | A | 4/1998 | Bass et al. | 6,035,653 | A | 3/2000 | Itoh et al. |
| 5,743,109 | A | 4/1998 | Schulak | 6,035,661 | A | 3/2000 | Sunaga et al. |
| 5,745,114 | A | 4/1998 | King et al. | 6,038,871 | A | 3/2000 | Gutierrez et al. |
| 5,749,238 | A | 5/1998 | Schmidt | 6,041,605 | A | 3/2000 | Heinrichs |
| 5,751,916 | A | 5/1998 | Kon et al. | 6,041,609 | A | 3/2000 | Hornsleth et al. |
| 5,752,385 | A | 5/1998 | Nelson | 6,041,856 | A | 3/2000 | Thrasher et al. |
| 5,754,450 | A | 5/1998 | Solomon et al. | 6,042,344 | A | 3/2000 | Lifson |
| 5,754,732 | A | 5/1998 | Vlahu | 6,044,062 | A | 3/2000 | Brownrigg et al. |
| 5,757,664 | A | 5/1998 | Rogers et al. | 6,047,557 | A | 4/2000 | Pham et al. |
| 5,757,892 | A | 5/1998 | Blanchard et al. | 6,050,098 | A | 4/2000 | Meyer et al. |
| 5,761,083 | A | 6/1998 | Brown, Jr. et al. | 6,050,780 | A | 4/2000 | Hasegawa et al. |
| 5,764,509 | A | 6/1998 | Gross et al. | 6,052,731 | A | 4/2000 | Holdsworth et al. |
| 5,772,214 | A | 6/1998 | Stark | 6,057,771 | A | 5/2000 | Lakra |
| 5,772,403 | A | 6/1998 | Allison et al. | 6,065,946 | A | 5/2000 | Lathrop |
| 5,782,101 | A | 7/1998 | Dennis | 6,068,447 | A | 5/2000 | Foege |
| 5,784,232 | A | 7/1998 | Farr | 6,070,110 | A | 5/2000 | Shah et al. |
| 5,790,898 | A | 8/1998 | Kishima et al. | 6,075,530 | A | 6/2000 | Lucas et al. |
| 5,795,381 | A | 8/1998 | Holder | 6,077,051 | A | 6/2000 | Centers et al. |
| 5,798,941 | A | 8/1998 | McLeister | 6,081,750 | A | 6/2000 | Hoffberg et al. |
| 5,802,860 | A | 9/1998 | Barrows | 6,082,495 | A | 7/2000 | Steinbarger et al. |
| 5,805,856 | A | 9/1998 | Hanson | 6,082,971 | A | 7/2000 | Gunn et al. |
| 5,807,336 | A | 9/1998 | Russo et al. | 6,085,530 | A | 7/2000 | Barito |
| 5,808,441 | A | 9/1998 | Nehring | 6,088,659 | A | 7/2000 | Kelley et al. |
| 5,810,908 | A | 9/1998 | Gray et al. | 6,088,688 | A | 7/2000 | Crooks et al. |
| 5,812,061 | A | 9/1998 | Simons | 6,092,370 | A | 7/2000 | Tremoulet, Jr. et al. |
| 5,825,597 | A | 10/1998 | Young | 6,092,378 | A | 7/2000 | Das et al. |
| 5,827,963 | A | 10/1998 | Selegatto et al. | 6,092,992 | A | 7/2000 | Imblum et al. |
| 5,839,094 | A | 11/1998 | French | 6,095,674 | A | 8/2000 | Verissimo et al. |
| 5,839,291 | A | 11/1998 | Chang et al. | 6,098,893 | A | 8/2000 | Berglund et al. |
| 5,841,654 | A | 11/1998 | Verissimo et al. | 6,102,665 | A | 8/2000 | Centers et al. |
| 5,857,348 | A | 1/1999 | Conry | 6,110,260 | A | 8/2000 | Kubokawa |
| 5,860,286 | A | 1/1999 | Tulpule | 6,119,949 | A | 9/2000 | Lindstrom |
| 5,861,807 | A | 1/1999 | Leyden et al. | 6,122,603 | A | 9/2000 | Budike, Jr. |
| 5,867,998 | A | 2/1999 | Guertin | 6,125,642 | A | 10/2000 | Seener et al. |
| 5,869,960 | A | 2/1999 | Brand | 6,128,583 | A | 10/2000 | Dowling |
| 5,873,257 | A | 2/1999 | Peterson | 6,128,953 | A | 10/2000 | Mizukoshi |
| 5,875,430 | A | 2/1999 | Koether | 6,129,527 | A | 10/2000 | Donahoe et al. |
| 5,875,638 | A | 3/1999 | Tinsler | 6,138,461 | A | 10/2000 | Park et al. |
| 5,884,494 | A | 3/1999 | Okoren et al. | 6,142,741 | A | 11/2000 | Nishihata et al. |
| 5,887,786 | A | 3/1999 | Sandelman | 6,144,888 | A | 11/2000 | Lucas et al. |
| 5,900,801 | A | 5/1999 | Heagle et al. | 6,145,328 | A | 11/2000 | Choi |
| 5,904,049 | A | 5/1999 | Jaster et al. | 6,147,601 | A | 11/2000 | Sandelman et al. |
| 5,918,200 | A | 6/1999 | Tsutsui et al. | 6,152,375 | A | 11/2000 | Robison |
| 5,924,295 | A | 7/1999 | Park | 6,152,376 | A | 11/2000 | Sandelman et al. |
| 5,924,486 | A | 7/1999 | Ehlers et al. | 6,153,942 | A | 11/2000 | Roseman et al. |
| | | | | 6,153,993 | A | 11/2000 | Oomura et al. |
| | | | | 6,154,488 | A | 11/2000 | Hunt |
| | | | | 6,157,310 | A | 12/2000 | Milne et al. |
| | | | | 6,158,230 | A | 12/2000 | Katsuki |
| | | | | 6,160,477 | A | 12/2000 | Sandelman et al. |

(56)

References Cited

U.S. PATENT DOCUMENTS

| | | | | | | | |
|-----------|----|---------|----------------------|-----------|----|---------|--------------------|
| 6,169,979 | B1 | 1/2001 | Johnson | 6,453,687 | B2 | 9/2002 | Sharood et al. |
| 6,172,476 | B1 | 1/2001 | Tolbert, Jr. et al. | 6,454,177 | B1 | 9/2002 | Sasao et al. |
| 6,174,136 | B1 | 1/2001 | Kilayko et al. | 6,454,538 | B1 | 9/2002 | Witham et al. |
| 6,176,683 | B1 | 1/2001 | Yang | 6,456,928 | B1 | 9/2002 | Johnson |
| 6,176,686 | B1 | 1/2001 | Wallis et al. | 6,457,319 | B1 | 10/2002 | Ota et al. |
| 6,177,884 | B1 | 1/2001 | Hunt et al. | 6,457,948 | B1 | 10/2002 | Pham |
| 6,178,362 | B1 | 1/2001 | Woolard et al. | 6,460,731 | B2 | 10/2002 | Estelle et al. |
| 6,179,214 | B1 | 1/2001 | Key et al. | 6,462,654 | B1 | 10/2002 | Sandelman et al. |
| 6,181,033 | B1 | 1/2001 | Wright | 6,463,747 | B1 | 10/2002 | Temple |
| 6,190,442 | B1 | 2/2001 | Redner | 6,466,971 | B1 | 10/2002 | Humpleman et al. |
| 6,191,545 | B1 | 2/2001 | Kawabata et al. | 6,467,280 | B2 | 10/2002 | Pham et al. |
| 6,192,282 | B1 | 2/2001 | Smith et al. | 6,471,486 | B1 | 10/2002 | Centers et al. |
| 6,199,018 | B1 | 3/2001 | Quist et al. | 6,474,084 | B2 | 11/2002 | Gauthier et al. |
| 6,211,782 | B1 | 4/2001 | Sandelman et al. | 6,484,520 | B2 | 11/2002 | Kawaguchi et al. |
| 6,213,731 | B1 | 4/2001 | Doepker et al. | 6,487,457 | B1 | 11/2002 | Hull et al. |
| 6,215,405 | B1 | 4/2001 | Handley et al. | 6,490,506 | B1 | 12/2002 | March |
| 6,216,956 | B1 | 4/2001 | Ehlers et al. | 6,492,923 | B1 | 12/2002 | Inoue et al. |
| 6,218,953 | B1 | 4/2001 | Petite | 6,497,554 | B2 | 12/2002 | Yang et al. |
| 6,223,543 | B1 | 5/2001 | Sandelman | 6,501,240 | B2 | 12/2002 | Ueda et al. |
| 6,223,544 | B1 | 5/2001 | Seem | 6,501,629 | B1 | 12/2002 | Marriott |
| 6,228,155 | B1 | 5/2001 | Tai | 6,502,409 | B1 | 1/2003 | Gatling et al. |
| 6,230,501 | B1 | 5/2001 | Bailey, Sr. et al. | 6,505,087 | B1 | 1/2003 | Lucas et al. |
| 6,233,327 | B1 | 5/2001 | Petite | 6,505,475 | B1 | 1/2003 | Zugibe et al. |
| 6,234,019 | B1 | 5/2001 | Caldeira | 6,510,350 | B1 | 1/2003 | Steen, III et al. |
| 6,240,733 | B1 | 6/2001 | Brandon et al. | 6,522,974 | B2 | 2/2003 | Sitton |
| 6,240,736 | B1 | 6/2001 | Fujita et al. | 6,523,130 | B1 | 2/2003 | Hickman et al. |
| 6,244,061 | B1 | 6/2001 | Takagi et al. | 6,526,766 | B1 | 3/2003 | Hiraoka et al. |
| 6,249,516 | B1 | 6/2001 | Brownrigg et al. | 6,529,590 | B1 | 3/2003 | Centers |
| 6,260,004 | B1 | 7/2001 | Hays et al. | 6,529,839 | B1 | 3/2003 | Uggerud et al. |
| 6,266,968 | B1 | 7/2001 | Redlich | 6,533,552 | B2 | 3/2003 | Centers et al. |
| 6,268,664 | B1 | 7/2001 | Rolls et al. | 6,535,123 | B2 | 3/2003 | Sandelman et al. |
| 6,272,868 | B1 | 8/2001 | Grabon et al. | 6,535,270 | B1 | 3/2003 | Murayama |
| 6,276,901 | B1 | 8/2001 | Farr et al. | 6,535,859 | B1 | 3/2003 | Yablonowski et al. |
| 6,279,332 | B1 | 8/2001 | Yeo et al. | 6,537,034 | B2 | 3/2003 | Park et al. |
| 6,290,043 | B1 | 9/2001 | Ginder et al. | 6,542,062 | B1 | 4/2003 | Herrick |
| 6,293,114 | B1 | 9/2001 | Kamemoto | 6,549,135 | B2 | 4/2003 | Singh et al. |
| 6,293,767 | B1 | 9/2001 | Bass | 6,551,069 | B2 | 4/2003 | Narney, II et al. |
| 6,302,654 | B1 | 10/2001 | Millet et al. | 6,553,774 | B1 | 4/2003 | Ishio et al. |
| 6,304,934 | B1 | 10/2001 | Pimenta et al. | 6,558,126 | B1 | 5/2003 | Hahn et al. |
| 6,320,275 | B1 | 11/2001 | Okamoto et al. | 6,560,976 | B2 | 5/2003 | Jayanth |
| 6,324,854 | B1 | 12/2001 | Jayanth | 6,571,280 | B1 | 5/2003 | Hubacher |
| 6,327,541 | B1 | 12/2001 | Pitchford et al. | 6,571,566 | B1 | 6/2003 | Temple et al. |
| 6,332,327 | B1 | 12/2001 | Street et al. | 6,571,586 | B1 | 6/2003 | Ritson et al. |
| 6,334,093 | B1 | 12/2001 | More | 6,574,561 | B2 | 6/2003 | Alexander et al. |
| 6,349,883 | B1 | 2/2002 | Simmons et al. | 6,577,959 | B1 | 6/2003 | Chajec et al. |
| 6,350,111 | B1 | 2/2002 | Perevozchikov et al. | 6,577,962 | B1 | 6/2003 | Afshari |
| 6,359,410 | B1 | 3/2002 | Randolph | 6,578,373 | B1 | 6/2003 | Barbier |
| 6,360,551 | B1 | 3/2002 | Renders | 6,583,720 | B1 | 6/2003 | Quigley |
| 6,366,889 | B1 | 4/2002 | Zaloom | 6,589,029 | B1 | 7/2003 | Heller |
| 6,368,065 | B1 | 4/2002 | Hugenroth et al. | 6,591,620 | B2 | 7/2003 | Kikuchi et al. |
| 6,375,439 | B1 | 4/2002 | Missio | 6,595,475 | B2 | 7/2003 | Svabek et al. |
| 6,378,315 | B1 | 4/2002 | Gelber et al. | 6,595,757 | B2 | 7/2003 | Shen |
| 6,381,971 | B2 | 5/2002 | Honda | 6,598,056 | B1 | 7/2003 | Hull et al. |
| 6,385,510 | B1 | 5/2002 | Hoog et al. | 6,601,397 | B2 | 8/2003 | Pham et al. |
| 6,389,823 | B1 | 5/2002 | Loprete et al. | 6,604,093 | B1 | 8/2003 | Etzion et al. |
| 6,390,779 | B1 | 5/2002 | Cunkelman | 6,609,070 | B1 | 8/2003 | Lueck |
| 6,391,102 | B1 | 5/2002 | Bodden et al. | 6,609,078 | B2 | 8/2003 | Starling et al. |
| 6,393,848 | B2 | 5/2002 | Roh et al. | 6,615,594 | B2 | 9/2003 | Jayanth et al. |
| 6,397,606 | B1 | 6/2002 | Roh et al. | 6,616,415 | B1 | 9/2003 | Renken et al. |
| 6,397,612 | B1 | 6/2002 | Kernkamp et al. | 6,618,578 | B1 | 9/2003 | Petite |
| 6,406,265 | B1 | 6/2002 | Hahn et al. | 6,618,709 | B1 | 9/2003 | Sneeringer |
| 6,406,266 | B1 | 6/2002 | Hugenroth et al. | 6,621,443 | B1 | 9/2003 | Selli et al. |
| 6,408,228 | B1 | 6/2002 | Seem et al. | 6,622,925 | B2 | 9/2003 | Carner et al. |
| 6,408,258 | B1 | 6/2002 | Richer | 6,622,926 | B1 | 9/2003 | Sartain et al. |
| 6,412,293 | B1 | 7/2002 | Pham et al. | 6,628,764 | B1 | 9/2003 | Petite |
| 6,414,594 | B1 | 7/2002 | Guerlain | 6,629,420 | B2 | 10/2003 | Renders |
| 6,430,268 | B1 | 8/2002 | Petite | 6,630,749 | B1 | 10/2003 | Takagi et al. |
| 6,433,791 | B2 | 8/2002 | Selli et al. | 6,631,298 | B1 | 10/2003 | Pagnano et al. |
| 6,437,691 | B1 | 8/2002 | Sandelman et al. | 6,636,893 | B1 | 10/2003 | Fong |
| 6,437,692 | B1 | 8/2002 | Petite et al. | 6,643,567 | B2 | 11/2003 | Kolk et al. |
| 6,438,981 | B1 | 8/2002 | Whiteside | 6,644,848 | B1 | 11/2003 | Clayton et al. |
| 6,442,953 | B1 | 9/2002 | Trigiani et al. | 6,647,735 | B2 | 11/2003 | Street et al. |
| 6,449,972 | B2 | 9/2002 | Pham et al. | 6,658,345 | B2 | 12/2003 | Miller |
| 6,450,771 | B1 | 9/2002 | Centers et al. | 6,658,373 | B2 | 12/2003 | Rossi et al. |
| 6,451,210 | B1 | 9/2002 | Sivavec et al. | 6,662,584 | B1 | 12/2003 | Whiteside |
| | | | | 6,662,653 | B1 | 12/2003 | Scalante et al. |
| | | | | 6,671,586 | B2 | 12/2003 | Davis et al. |
| | | | | 6,672,846 | B2 | 1/2004 | Rajendran et al. |
| | | | | 6,675,591 | B2 | 1/2004 | Singh et al. |

(56)

References Cited

U.S. PATENT DOCUMENTS

| | | | | | | |
|---------------|---------|--------------------------|-----------------------|--------------|---------|-------------------|
| 6,679,072 B2 | 1/2004 | Pham et al. | | 6,990,821 B2 | 1/2006 | Singh et al. |
| 6,681,582 B2* | 1/2004 | Suzuki | B60H 1/3225 62/129 | 6,992,452 B1 | 1/2006 | Sachs et al. |
| 6,684,349 B2 | 1/2004 | Gullo et al. | | 6,996,441 B1 | 2/2006 | Tobias |
| 6,685,438 B2 | 2/2004 | Yoo et al. | | 6,997,390 B2 | 2/2006 | Alles |
| 6,698,218 B2 | 3/2004 | Goth et al. | | 6,998,807 B2 | 2/2006 | Phillips et al. |
| 6,701,725 B2 | 3/2004 | Rossi et al. | | 6,998,963 B2 | 2/2006 | Flen et al. |
| 6,708,083 B2 | 3/2004 | Orthlieb et al. | | 6,999,996 B2 | 2/2006 | Sunderland |
| 6,708,508 B2 | 3/2004 | Demuth et al. | | 7,000,422 B2 | 2/2006 | Street et al. |
| 6,709,244 B2 | 3/2004 | Pham | | 7,003,378 B2 | 2/2006 | Poth |
| 6,711,470 B1 | 3/2004 | Hartenstein et al. | | 7,009,510 B1 | 3/2006 | Douglass et al. |
| 6,711,911 B1 | 3/2004 | Grabon et al. | | 7,010,925 B2 | 3/2006 | Siemel et al. |
| 6,717,513 B1 | 4/2004 | Sandelman et al. | | 7,019,667 B2 | 3/2006 | Petite et al. |
| 6,721,770 B1 | 4/2004 | Morton et al. | | 7,024,665 B2 | 4/2006 | Ferraz et al. |
| 6,725,182 B2 | 4/2004 | Pagnano et al. | | 7,024,870 B2 | 4/2006 | Singh et al. |
| 6,732,538 B2 | 5/2004 | Trigiani et al. | | 7,030,752 B2 | 4/2006 | Tyroler |
| 6,745,107 B1 | 6/2004 | Miller | | 7,031,880 B1 | 4/2006 | Seem et al. |
| 6,747,557 B1 | 6/2004 | Petite et al. | | 7,035,693 B2 | 4/2006 | Cassiolato et al. |
| 6,757,665 B1 | 6/2004 | Unsworth et al. | | 7,039,532 B2 | 5/2006 | Hunter |
| 6,758,050 B2 | 7/2004 | Jayanth et al. | | 7,042,180 B2 | 5/2006 | Terry et al. |
| 6,758,051 B2 | 7/2004 | Jayanth et al. | | 7,042,350 B2 | 5/2006 | Patrick et al. |
| 6,760,207 B2 | 7/2004 | Wyatt et al. | | 7,043,339 B2 | 5/2006 | Maeda et al. |
| 6,772,096 B2 | 8/2004 | Murakami et al. | | 7,043,459 B2 | 5/2006 | Peevey |
| 6,772,598 B1 | 8/2004 | Rinehart | | 7,047,753 B2 | 5/2006 | Street et al. |
| 6,775,995 B1 | 8/2004 | Bahel et al. | | 7,053,766 B2 | 5/2006 | Fisler et al. |
| 6,784,807 B2 | 8/2004 | Petite et al. | | 7,053,767 B2 | 5/2006 | Petite et al. |
| 6,785,592 B1 | 8/2004 | Smith et al. | | 7,054,271 B2 | 5/2006 | Brownrigg et al. |
| 6,786,473 B1 | 9/2004 | Alles | | 7,062,580 B2 | 6/2006 | Donaires |
| 6,799,951 B2 | 10/2004 | Lifson et al. | | 7,062,830 B2 | 6/2006 | Alles |
| 6,804,993 B2 | 10/2004 | Selli | | 7,063,537 B2 | 6/2006 | Selli et al. |
| 6,811,380 B2 | 11/2004 | Kim | | 7,072,797 B2 | 7/2006 | Gorinevsky |
| 6,813,897 B1 | 11/2004 | Bash et al. | | 7,075,327 B2 | 7/2006 | Dimino et al. |
| 6,816,811 B2 | 11/2004 | Seem | | 7,079,810 B2 | 7/2006 | Petite et al. |
| 6,823,680 B2 | 11/2004 | Jayanth | | 7,079,967 B2 | 7/2006 | Rossi et al. |
| 6,829,542 B1 | 12/2004 | Reynolds et al. | | 7,082,380 B2 | 7/2006 | Wiebe et al. |
| 6,832,120 B1 | 12/2004 | Frank et al. | | 7,089,125 B2 | 8/2006 | Sonderegger |
| 6,832,898 B2 | 12/2004 | Yoshida et al. | | 7,091,847 B2 | 8/2006 | Capowski et al. |
| 6,836,737 B2 | 12/2004 | Petite et al. | | 7,092,767 B2 | 8/2006 | Pagnano et al. |
| 6,837,922 B2 | 1/2005 | Gorin | | 7,092,794 B1 | 8/2006 | Hill et al. |
| 6,839,790 B2 | 1/2005 | Barros De Almeida et al. | | 7,096,153 B2 | 8/2006 | Guralnik et al. |
| 6,854,345 B2 | 2/2005 | Alves et al. | | 7,102,490 B2 | 9/2006 | Flen et al. |
| 6,862,498 B2 | 3/2005 | Davis et al. | | 7,103,511 B2 | 9/2006 | Petite |
| 6,868,678 B2 | 3/2005 | Mei et al. | | 7,110,843 B2 | 9/2006 | Pagnano et al. |
| 6,868,686 B2 | 3/2005 | Ueda et al. | | 7,110,898 B2 | 9/2006 | Montijo et al. |
| 6,869,272 B2 | 3/2005 | Odachi et al. | | 7,113,376 B2 | 9/2006 | Nomura et al. |
| 6,870,486 B2 | 3/2005 | Souza et al. | | 7,114,343 B2 | 10/2006 | Kates |
| 6,885,949 B2 | 4/2005 | Selli | | 7,123,020 B2 | 10/2006 | Hill et al. |
| 6,889,173 B2 | 5/2005 | Singh | | 7,123,458 B2 | 10/2006 | Mohr et al. |
| 6,891,838 B1 | 5/2005 | Petite et al. | | 7,124,728 B2 | 10/2006 | Carey et al. |
| 6,892,546 B2 | 5/2005 | Singh et al. | | 7,126,465 B2 | 10/2006 | Faltsek |
| 6,897,772 B1 | 5/2005 | Scheffler et al. | | 7,130,170 B2 | 10/2006 | Wakefield et al. |
| 6,900,738 B2 | 5/2005 | Crichlow | | 7,130,832 B2 | 10/2006 | Bannai et al. |
| 6,901,066 B1 | 5/2005 | Helgeson | | 7,134,295 B2 | 11/2006 | Maekawa |
| 6,904,385 B1 | 6/2005 | Budike, Jr. | | 7,137,550 B1 | 11/2006 | Petite |
| 6,914,533 B2 | 7/2005 | Petite | | 7,142,125 B2 | 11/2006 | Larson et al. |
| 6,914,893 B2 | 7/2005 | Petite | | 7,145,438 B2 | 12/2006 | Flen et al. |
| 6,922,155 B1 | 7/2005 | Evans et al. | | 7,145,462 B2 | 12/2006 | Dewing et al. |
| 6,931,445 B2 | 8/2005 | Davis | | 7,159,408 B2 | 1/2007 | Sadegh et al. |
| 6,934,862 B2 | 8/2005 | Sharood et al. | | 7,162,884 B2 | 1/2007 | Alles |
| 6,952,658 B2 | 10/2005 | Greulich et al. | | 7,163,158 B2 | 1/2007 | Rossi et al. |
| 6,953,630 B2 | 10/2005 | Wells | | 7,171,372 B2 | 1/2007 | Daniel et al. |
| 6,956,344 B2 | 10/2005 | Robertson et al. | | 7,174,728 B2 | 2/2007 | Jayanth |
| 6,964,558 B2 | 11/2005 | Hahn et al. | | 7,180,412 B2 | 2/2007 | Bonicatto et al. |
| 6,966,759 B2 | 11/2005 | Hahn et al. | | 7,184,861 B2 | 2/2007 | Petite |
| 6,968,295 B1 | 11/2005 | Carr | | 7,188,482 B2 | 3/2007 | Sadegh et al. |
| 6,973,410 B2 | 12/2005 | Seigel | | 7,188,779 B2 | 3/2007 | Alles |
| 6,973,793 B2 | 12/2005 | Douglas et al. | | 7,201,006 B2 | 4/2007 | Kates |
| 6,973,794 B2 | 12/2005 | Street et al. | | 7,207,496 B2 | 4/2007 | Alles |
| 6,976,366 B2 | 12/2005 | Starling et al. | | 7,209,840 B2 | 4/2007 | Petite et al. |
| 6,978,225 B2 | 12/2005 | Retlich et al. | | 7,212,887 B2 | 5/2007 | Shah et al. |
| 6,981,384 B2 | 1/2006 | Dobmeier et al. | | 7,222,493 B2 | 5/2007 | Jayanth et al. |
| 6,983,321 B2 | 1/2006 | Trinon et al. | | 7,224,740 B2 | 5/2007 | Hunt |
| 6,983,889 B2 | 1/2006 | Alles | | 7,225,193 B2 | 5/2007 | Mets et al. |
| 6,986,469 B2 | 1/2006 | Gauthier et al. | | 7,227,450 B2 | 6/2007 | Garvy et al. |
| 6,987,450 B2 | 1/2006 | Marino et al. | | 7,228,691 B2 | 6/2007 | Street et al. |
| | | | | 7,230,528 B2 | 6/2007 | Kates |
| | | | | 7,234,313 B2 | 6/2007 | Bell et al. |
| | | | | 7,236,765 B2 | 6/2007 | Bonicatto et al. |
| | | | | 7,244,294 B2 | 7/2007 | Kates |
| | | | | 7,246,014 B2 | 7/2007 | Forth et al. |

| | | | | | |
|------|------------------------------|----------------|---------|----------------------|-----------------------|
| (56) | References Cited | 7,552,596 B2 * | 6/2009 | Galante | F25B 45/00 62/127 |
| | U.S. PATENT DOCUMENTS | 7,555,364 B2 | 6/2009 | Poth et al. | |
| | | 7,574,333 B2 | 8/2009 | Lu | |
| | | 7,580,812 B2 | 8/2009 | Ariyur et al. | |
| | | 7,594,407 B2 | 9/2009 | Singh et al. | |
| | | 7,596,959 B2 | 10/2009 | Singh et al. | |
| | | 7,606,683 B2 | 10/2009 | Bahel et al. | |
| | | 7,631,508 B2 | 12/2009 | Braun et al. | |
| | | 7,636,901 B2 | 12/2009 | Munson et al. | |
| | | 7,644,591 B2 | 1/2010 | Singh et al. | |
| | | 7,648,077 B2 | 1/2010 | Rossi et al. | |
| | | 7,648,342 B2 | 1/2010 | Jayanth | |
| | | 7,650,425 B2 | 1/2010 | Davis et al. | |
| | | 7,660,700 B2 | 2/2010 | Moskowitz et al. | |
| | | 7,660,774 B2 | 2/2010 | Mukherjee et al. | |
| | | 7,664,613 B2 | 2/2010 | Hansen | |
| | | 7,665,315 B2 | 2/2010 | Singh et al. | |
| | | 7,686,872 B2 | 3/2010 | Kang | |
| | | 7,693,809 B2 | 4/2010 | Gray | |
| | | 7,697,492 B2 | 4/2010 | Petite | |
| | | 7,703,694 B2 | 4/2010 | Mueller et al. | |
| | | 7,704,052 B2 | 4/2010 | Iimura et al. | |
| | | 7,706,320 B2 | 4/2010 | Davis et al. | |
| | | 7,724,131 B2 | 5/2010 | Chen | |
| | | 7,726,583 B2 | 6/2010 | Maekawa | |
| | | 7,734,451 B2 | 6/2010 | MacArthur et al. | |
| | | 7,738,999 B2 | 6/2010 | Petite | |
| | | 7,739,378 B2 | 6/2010 | Petite | |
| | | 7,742,393 B2 | 6/2010 | Bonicatto et al. | |
| | | 7,752,853 B2 | 7/2010 | Singh et al. | |
| | | 7,752,854 B2 | 7/2010 | Singh et al. | |
| | | 7,756,086 B2 | 7/2010 | Petite et al. | |
| | | 7,791,468 B2 | 9/2010 | Bonicatto et al. | |
| | | 7,844,366 B2 | 11/2010 | Singh | |
| | | 7,845,179 B2 | 12/2010 | Singh et al. | |
| | | 7,848,827 B2 | 12/2010 | Chen | |
| | | 7,848,900 B2 | 12/2010 | Steinberg et al. | |
| | | 7,877,218 B2 | 1/2011 | Bonicatto et al. | |
| | | 7,878,006 B2 | 2/2011 | Pham | |
| | | 7,885,959 B2 | 2/2011 | Horowitz et al. | |
| | | 7,885,961 B2 | 2/2011 | Horowitz et al. | |
| | | 7,905,098 B2 | 3/2011 | Pham | |
| | | 7,908,116 B2 | 3/2011 | Steinberg et al. | |
| | | 7,908,117 B2 | 3/2011 | Steinberg et al. | |
| | | 7,922,914 B1 | 4/2011 | Verdegan et al. | |
| | | 7,937,623 B2 | 5/2011 | Ramacher et al. | |
| | | 7,941,294 B2 | 5/2011 | Shahi et al. | |
| | | 7,949,494 B2 | 5/2011 | Moskowitz et al. | |
| | | 7,949,615 B2 | 5/2011 | Ehlers et al. | |
| | | 7,963,454 B2 | 6/2011 | Sullivan et al. | |
| | | 7,966,152 B2 | 6/2011 | Stluka et al. | |
| | | 7,967,218 B2 | 6/2011 | Alles | |
| | | 7,978,059 B2 | 7/2011 | Petite et al. | |
| | | 7,987,679 B2 | 8/2011 | Tanaka et al. | |
| | | 7,996,045 B1 | 8/2011 | Bauer et al. | |
| | | 7,999,668 B2 | 8/2011 | Cawthorne et al. | |
| | | 8,000,314 B2 | 8/2011 | Brownrigg et al. | |
| | | 8,002,199 B2 | 8/2011 | Habegger | |
| | | 8,005,640 B2 | 8/2011 | Chiefertz et al. | |
| | | 8,010,237 B2 | 8/2011 | Cheung et al. | |
| | | 8,013,732 B2 | 9/2011 | Petite et al. | |
| | | 8,018,182 B2 | 9/2011 | Roehm et al. | |
| | | 8,019,567 B2 | 9/2011 | Steinberg et al. | |
| | | 8,029,608 B1 | 10/2011 | Breslin | |
| | | 8,031,455 B2 | 10/2011 | Paik et al. | |
| | | 8,031,650 B2 | 10/2011 | Petite et al. | |
| | | 8,034,170 B2 | 10/2011 | Kates | |
| | | 8,036,844 B2 | 10/2011 | Ling et al. | |
| | | 8,040,231 B2 | 10/2011 | Kuruvila et al. | |
| | | 8,041,539 B2 | 10/2011 | Guralnik et al. | |
| | | 8,046,107 B2 | 10/2011 | Zugibe et al. | |
| | | 8,061,417 B2 | 11/2011 | Gray | |
| | | 8,064,412 B2 | 11/2011 | Petite | |
| | | 8,065,886 B2 | 11/2011 | Singh et al. | |
| | | 8,068,997 B2 | 11/2011 | Ling et al. | |
| | | 8,090,477 B1 | 1/2012 | Steinberg | |
| | | 8,090,559 B2 | 1/2012 | Parthasarathy et al. | |
| | | 8,090,824 B2 | 1/2012 | Tran et al. | |
| | | 7,255,285 B2 | 8/2007 | Troost et al. | |
| | | 7,257,501 B2 | 8/2007 | Zhan et al. | |
| | | 7,260,505 B2 | 8/2007 | Felke et al. | |
| | | 7,261,762 B2 | 8/2007 | Kang et al. | |
| | | 7,263,073 B2 | 8/2007 | Petite et al. | |
| | | 7,263,446 B2 | 8/2007 | Morin et al. | |
| | | 7,266,812 B2 | 9/2007 | Pagnano | |
| | | 7,270,278 B2 | 9/2007 | Street et al. | |
| | | 7,274,995 B2 | 9/2007 | Zhan et al. | |
| | | 7,275,377 B2 | 10/2007 | Kates | |
| | | 7,286,945 B2 | 10/2007 | Zhan et al. | |
| | | 7,290,398 B2 | 11/2007 | Wallace et al. | |
| | | 7,290,989 B2 | 11/2007 | Jayanth | |
| | | 7,295,128 B2 | 11/2007 | Petite | |
| | | 7,295,896 B2 | 11/2007 | Norbeck | |
| | | 7,317,952 B2 | 1/2008 | Bhandiwad et al. | |
| | | 7,328,192 B1 | 2/2008 | Stengard et al. | |
| | | 7,330,886 B2 | 2/2008 | Childers et al. | |
| | | 7,331,187 B2 | 2/2008 | Kates | |
| | | 7,336,168 B2 | 2/2008 | Kates | |
| | | 7,337,191 B2 | 2/2008 | Haerberle et al. | |
| | | 7,343,750 B2 | 3/2008 | Lifson et al. | |
| | | 7,343,751 B2 | 3/2008 | Kates | |
| | | 7,346,463 B2 | 3/2008 | Petite et al. | |
| | | 7,346,472 B1 | 3/2008 | Moskowitz et al. | |
| | | 7,349,824 B2 | 3/2008 | Seigel | |
| | | 7,350,112 B2 | 3/2008 | Fox et al. | |
| | | 7,351,274 B2 | 4/2008 | Helt et al. | |
| | | 7,352,545 B2 | 4/2008 | Wyatt et al. | |
| | | 7,363,200 B2 | 4/2008 | Lu | |
| | | 7,376,712 B1 | 5/2008 | Granatelli et al. | |
| | | 7,377,118 B2 | 5/2008 | Esslinger | |
| | | 7,383,030 B2 | 6/2008 | Brown et al. | |
| | | 7,383,158 B2 | 6/2008 | Krocker et al. | |
| | | 7,392,661 B2 | 7/2008 | Alles | |
| | | 7,397,907 B2 | 7/2008 | Petite | |
| | | 7,400,240 B2 | 7/2008 | Shrode et al. | |
| | | 7,412,842 B2 | 8/2008 | Pham | |
| | | 7,414,525 B2 | 8/2008 | Costea et al. | |
| | | 7,421,351 B2 | 9/2008 | Navratil | |
| | | 7,421,374 B2 | 9/2008 | Zhan et al. | |
| | | 7,421,850 B2 | 9/2008 | Street et al. | |
| | | 7,424,343 B2 | 9/2008 | Kates | |
| | | 7,424,345 B2 | 9/2008 | Norbeck | |
| | | 7,424,527 B2 | 9/2008 | Petite | |
| | | 7,432,824 B2 | 10/2008 | Flen et al. | |
| | | 7,433,854 B2 | 10/2008 | Joseph et al. | |
| | | 7,434,742 B2 | 10/2008 | Mueller et al. | |
| | | 7,437,150 B1 | 10/2008 | Morelli et al. | |
| | | 7,440,560 B1 | 10/2008 | Barry | |
| | | 7,440,767 B2 | 10/2008 | Ballay et al. | |
| | | 7,443,313 B2 | 10/2008 | Davis et al. | |
| | | 7,444,251 B2 | 10/2008 | Nikovski et al. | |
| | | 7,445,665 B2 | 11/2008 | Hsieh et al. | |
| | | 7,447,603 B2 | 11/2008 | Bruno | |
| | | 7,447,609 B2 | 11/2008 | Guralnik et al. | |
| | | 7,451,606 B2 | 11/2008 | Harrod | |
| | | 7,454,439 B1 | 11/2008 | Gansner et al. | |
| | | 7,458,223 B2 | 12/2008 | Pham | |
| | | 7,468,661 B2 | 12/2008 | Petite et al. | |
| | | 7,469,546 B2 * | 12/2008 | Kates | F25B 49/005 62/129 |
| | | 7,474,992 B2 | 1/2009 | Ariyur | |
| | | 7,480,501 B2 | 1/2009 | Petite | |
| | | 7,483,810 B2 | 1/2009 | Jackson et al. | |
| | | 7,484,376 B2 | 2/2009 | Pham | |
| | | 7,490,477 B2 | 2/2009 | Singh et al. | |
| | | 7,491,034 B2 | 2/2009 | Jayanth | |
| | | 7,503,182 B2 | 3/2009 | Bahel et al. | |
| | | 7,510,126 B2 | 3/2009 | Rossi et al. | |
| | | 7,523,619 B2 | 4/2009 | Kojima et al. | |
| | | 7,528,711 B2 | 5/2009 | Kates | |
| | | 7,533,070 B2 | 5/2009 | Guralnik et al. | |
| | | 7,537,172 B2 | 5/2009 | Rossi et al. | |
| | | 7,552,030 B2 | 6/2009 | Guralnik et al. | |

| (56) | | References Cited | | | | | |
|--------------|----|-----------------------|-------------------|--------------|-----|---------|-------------------------------------|
| | | U.S. PATENT DOCUMENTS | | | | | |
| 8,095,337 | B2 | 1/2012 | Kolbet et al. | 2002/0198629 | A1 | 12/2002 | Ellis |
| 8,108,200 | B2 | 1/2012 | Anne et al. | 2003/0004660 | A1 | 1/2003 | Hunter |
| 8,125,230 | B2 | 2/2012 | Bharadwaj et al. | 2003/0004765 | A1 | 1/2003 | Wiegand |
| 8,131,497 | B2 | 3/2012 | Steinberg et al. | 2003/0005710 | A1 | 1/2003 | Singh et al. |
| 8,131,506 | B2 | 3/2012 | Steinberg et al. | 2003/0006884 | A1 | 1/2003 | Hunt |
| 8,134,330 | B2 | 3/2012 | Alles | 2003/0014218 | A1 | 1/2003 | Trigiani et al. |
| 8,150,720 | B2 | 4/2012 | Singh et al. | 2003/0019221 | A1 | 1/2003 | Rossi et al. |
| 8,156,208 | B2 | 4/2012 | Bornhoeved et al. | 2003/0036810 | A1 | 2/2003 | Petite |
| 8,160,827 | B2 | 4/2012 | Jayanth et al. | 2003/0037555 | A1 | 2/2003 | Street et al. |
| 8,170,968 | B2 | 5/2012 | Colclough et al. | 2003/0050737 | A1 | 3/2003 | Osann |
| 8,171,136 | B2 | 5/2012 | Petite | 2003/0050824 | A1 | 3/2003 | Suermondt et al. |
| 8,175,846 | B2 | 5/2012 | Khalak et al. | 2003/0051490 | A1 | 3/2003 | Jayanth |
| 8,180,492 | B2 | 5/2012 | Steinberg | 2003/0055603 | A1 | 3/2003 | Rossi et al. |
| 8,182,579 | B2 | 5/2012 | Woo et al. | 2003/0055663 | A1 | 3/2003 | Struble |
| 8,214,175 | B2 | 7/2012 | Moskowitz et al. | 2003/0061825 | A1 | 4/2003 | Sullivan |
| 8,228,648 | B2 | 7/2012 | Jayanth et al. | 2003/0063983 | A1 | 4/2003 | Ancel et al. |
| 8,239,922 | B2 | 8/2012 | Sullivan et al. | 2003/0070438 | A1 | 4/2003 | Kikuchi et al. |
| 8,258,763 | B2 | 9/2012 | Nakamura et al. | 2003/0070544 | A1 | 4/2003 | Mulvaney et al. |
| 8,279,565 | B2 | 10/2012 | Hall et al. | 2003/0074285 | A1 | 4/2003 | Hoffman et al. |
| 8,280,536 | B1 | 10/2012 | Fadell et al. | 2003/0077179 | A1 | 4/2003 | Collins et al. |
| 8,328,524 | B2 | 12/2012 | Iimura et al. | 2003/0078677 | A1 | 4/2003 | Hull et al. |
| 8,335,657 | B2 | 12/2012 | Jayanth et al. | 2003/0078742 | A1 | 4/2003 | VanderZee et al. |
| 8,380,556 | B2 | 2/2013 | Singh et al. | 2003/0089493 | A1 | 5/2003 | Takano et al. |
| 8,393,169 | B2 | 3/2013 | Pham | 2003/0094004 | A1 | 5/2003 | Pham et al. |
| 8,625,244 | B2 | 1/2014 | Paik et al. | 2003/0108430 | A1 | 6/2003 | Yoshida et al. |
| 9,046,900 | B2 | 6/2015 | Kates | 2003/0115890 | A1 | 6/2003 | Jayanth et al. |
| 9,168,315 | B1 | 10/2015 | Scaringe et al. | 2003/0135786 | A1 | 7/2003 | Vollmar et al. |
| 9,304,521 | B2 | 4/2016 | Kates | 2003/0137396 | A1 | 7/2003 | Durej et al. |
| 9,310,094 | B2 | 4/2016 | Kates | 2003/0150924 | A1 | 8/2003 | Peter |
| 9,310,439 | B2 | 4/2016 | Pham et al. | 2003/0150926 | A1 | 8/2003 | Rosen |
| 9,690,307 | B2 | 6/2017 | Kates | 2003/0150927 | A1 | 8/2003 | Rosen |
| 9,765,979 | B2 | 9/2017 | Alsaleem et al. | 2003/0171851 | A1 | 9/2003 | Brickfield et al. |
| 2001/0005320 | A1 | 6/2001 | Ueda et al. | 2003/0183085 | A1 | 10/2003 | Alexander |
| 2001/0023596 | A1 | 9/2001 | Fujita et al. | 2003/0191606 | A1 | 10/2003 | Fujiyama et al. |
| 2001/0025349 | A1 | 9/2001 | Sharood et al. | 2003/0199247 | A1 | 10/2003 | Striemer |
| 2001/0054291 | A1 | 12/2001 | Roh et al. | 2003/0205143 | A1 | 11/2003 | Cheng |
| 2001/0054293 | A1 | 12/2001 | Gustafson et al. | 2003/0213256 | A1 | 11/2003 | Ueda et al. |
| 2001/0054294 | A1 | 12/2001 | Tsuboi | 2003/0213851 | A1 | 11/2003 | Burd et al. |
| 2002/0000092 | A1 | 1/2002 | Sharood et al. | 2003/0216837 | A1 | 11/2003 | Reich et al. |
| 2002/0013679 | A1 | 1/2002 | Petite | 2003/0216888 | A1 | 11/2003 | Ridolfo |
| 2002/0016639 | A1 | 2/2002 | Smith et al. | 2003/0233172 | A1 | 12/2003 | Granqvist et al. |
| 2002/0017057 | A1 | 2/2002 | Weder | 2004/0016241 | A1 | 1/2004 | Street et al. |
| 2002/0018724 | A1 | 2/2002 | Millet et al. | 2004/0016244 | A1 | 1/2004 | Street et al. |
| 2002/0020175 | A1 | 2/2002 | Street et al. | 2004/0016251 | A1 | 1/2004 | Street et al. |
| 2002/0029575 | A1 | 3/2002 | Okamoto | 2004/0016253 | A1 | 1/2004 | Street et al. |
| 2002/0031101 | A1 | 3/2002 | Petite et al. | 2004/0019584 | A1 | 1/2004 | Greening et al. |
| 2002/0035495 | A1 | 3/2002 | Spira et al. | 2004/0024495 | A1 | 2/2004 | Sunderland |
| 2002/0040280 | A1 | 4/2002 | Morgan | 2004/0026522 | A1 | 2/2004 | Keen et al. |
| 2002/0059803 | A1 | 5/2002 | Jayanth | 2004/0037706 | A1 | 2/2004 | Hahn et al. |
| 2002/0064463 | A1 | 5/2002 | Park et al. | 2004/0042904 | A1 | 3/2004 | Kim |
| 2002/0067999 | A1 | 6/2002 | Suitou et al. | 2004/0047406 | A1 | 3/2004 | Hunt |
| 2002/0082747 | A1 | 6/2002 | Kramer | 2004/0049715 | A1 | 3/2004 | Jaw |
| 2002/0082924 | A1 | 6/2002 | Koether | 2004/0059691 | A1 | 3/2004 | Higgins |
| 2002/0093259 | A1 | 7/2002 | Sunaga et al. | 2004/0068390 | A1 | 4/2004 | Saunders |
| 2002/0095269 | A1 | 7/2002 | Natalini et al. | 2004/0078695 | A1 | 4/2004 | Bowers et al. |
| 2002/0103655 | A1 | 8/2002 | Boies et al. | 2004/0079093 | A1 | 4/2004 | Gauthier et al. |
| 2002/0108384 | A1 | 8/2002 | Higashiyama | 2004/0093879 | A1 | 5/2004 | Street et al. |
| 2002/0113877 | A1 | 8/2002 | Welch | 2004/0095237 | A1 | 5/2004 | Chen et al. |
| 2002/0117992 | A1 | 8/2002 | Hirono et al. | 2004/0111186 | A1 | 6/2004 | Rossi et al. |
| 2002/0118106 | A1 | 8/2002 | Brenn | 2004/0117166 | A1 | 6/2004 | Cassiolato |
| 2002/0127120 | A1 | 9/2002 | Hahn et al. | 2004/0133314 | A1 | 7/2004 | Ehlers et al. |
| 2002/0138217 | A1 | 9/2002 | Shen et al. | 2004/0133367 | A1 | 7/2004 | Hart |
| 2002/0139128 | A1 | 10/2002 | Suzuki et al. | 2004/0140772 | A1 | 7/2004 | Gullo et al. |
| 2002/0143482 | A1 | 10/2002 | Karanam et al. | 2004/0140812 | A1 | 7/2004 | Scallante et al. |
| 2002/0152298 | A1 | 10/2002 | Kikta et al. | 2004/0144106 | A1 | 7/2004 | Douglas et al. |
| 2002/0157408 | A1 | 10/2002 | Egawa et al. | 2004/0153437 | A1 | 8/2004 | Buchan |
| 2002/0157409 | A1 | 10/2002 | Pham et al. | 2004/0159113 | A1 | 8/2004 | Singh et al. |
| 2002/0159890 | A1 | 10/2002 | Kajiwarra et al. | 2004/0159114 | A1* | 8/2004 | Demuth B60H 1/00978 62/129 |
| 2002/0161545 | A1 | 10/2002 | Starling et al. | 2004/0183687 | A1 | 9/2004 | Petite et al. |
| 2002/0163436 | A1 | 11/2002 | Singh et al. | 2004/0184627 | A1 | 9/2004 | Kost et al. |
| 2002/0170299 | A1 | 11/2002 | Jayanth et al. | 2004/0184928 | A1 | 9/2004 | Millet et al. |
| 2002/0173929 | A1 | 11/2002 | Seigel | 2004/0184929 | A1 | 9/2004 | Millet et al. |
| 2002/0187057 | A1 | 12/2002 | Loprete et al. | 2004/0184930 | A1 | 9/2004 | Millet et al. |
| 2002/0189267 | A1 | 12/2002 | Singh et al. | 2004/0184931 | A1 | 9/2004 | Millet et al. |
| 2002/0193890 | A1 | 12/2002 | Pouchak | 2004/0187502 | A1 | 9/2004 | Jayanth et al. |
| | | | | 2004/0191073 | A1 | 9/2004 | Iimura et al. |
| | | | | 2004/0199480 | A1 | 10/2004 | Unsworth et al. |
| | | | | 2004/0210419 | A1 | 10/2004 | Wiebe et al. |

(56)

References Cited

U.S. PATENT DOCUMENTS

| | | | | | | | | |
|--------------|-----|---------|---------------------------------|--------------|-----|---------|---|--|
| 2004/0213384 | A1 | 10/2004 | Alles et al. | 2006/0179854 | A1 | 8/2006 | Esslinger | |
| 2004/0230582 | A1 | 11/2004 | Pagnano et al. | 2006/0182635 | A1 | 8/2006 | Jayanth | |
| 2004/0230899 | A1 | 11/2004 | Pagnano et al. | 2006/0185373 | A1 | 8/2006 | Butler et al. | |
| 2004/0239266 | A1 | 12/2004 | Lee et al. | 2006/0196196 | A1 | 9/2006 | Kates | |
| 2004/0258542 | A1 | 12/2004 | Wiertz et al. | 2006/0196197 | A1 | 9/2006 | Kates | |
| 2004/0261431 | A1 | 12/2004 | Singh et al. | 2006/0201168 | A1 | 9/2006 | Kates | |
| 2005/0040249 | A1 | 2/2005 | Wacker et al. | 2006/0222507 | A1 | 10/2006 | Jayanth | |
| 2005/0043923 | A1 | 2/2005 | Forster et al. | 2006/0229739 | A1 | 10/2006 | Morikawa | |
| 2005/0053471 | A1 | 3/2005 | Hong et al. | 2006/0235650 | A1 | 10/2006 | Vinberg et al. | |
| 2005/0056031 | A1 | 3/2005 | Jeong | 2006/0238388 | A1 | 10/2006 | Jayanth | |
| 2005/0066675 | A1 | 3/2005 | Manole et al. | 2006/0242200 | A1 | 10/2006 | Horowitz et al. | |
| 2005/0073532 | A1 | 4/2005 | Scott et al. | 2006/0244641 | A1 | 11/2006 | Jayanth et al. | |
| 2005/0086341 | A1 | 4/2005 | Enga et al. | 2006/0256488 | A1 | 11/2006 | Benzing et al. | |
| 2005/0100449 | A1 | 5/2005 | Hahn et al. | 2006/0259276 | A1 | 11/2006 | Rossi et al. | |
| 2005/0103036 | A1 | 5/2005 | Maekawa | 2006/0271589 | A1 | 11/2006 | Horowitz et al. | |
| 2005/0125439 | A1 | 6/2005 | Nourbakhsh et al. | 2006/0271623 | A1 | 11/2006 | Horowitz et al. | |
| 2005/0126190 | A1 | 6/2005 | Lifson et al. | 2006/0280627 | A1 | 12/2006 | Jayanth | |
| 2005/0131624 | A1 | 6/2005 | Gaessler et al. | 2007/0002505 | A1 | 1/2007 | Watanabe et al. | |
| 2005/0149570 | A1 | 7/2005 | Sasaki et al. | 2007/0006124 | A1 | 1/2007 | Ahmed et al. | |
| 2005/0154495 | A1 | 7/2005 | Shah | 2007/0027735 | A1 | 2/2007 | Rokos | |
| 2005/0159924 | A1 | 7/2005 | Shah et al. | 2007/0067512 | A1 | 3/2007 | Donaires et al. | |
| 2005/0166610 | A1 | 8/2005 | Jayanth | 2007/0089434 | A1 | 4/2007 | Singh et al. | |
| 2005/0169636 | A1 | 8/2005 | Aronson et al. | 2007/0089435 | A1 | 4/2007 | Singh et al. | |
| 2005/0172647 | A1 | 8/2005 | Thybo et al. | 2007/0089438 | A1 | 4/2007 | Singh et al. | |
| 2005/0188842 | A1 | 9/2005 | Hsieh et al. | 2007/0089439 | A1 | 4/2007 | Singh et al. | |
| 2005/0195775 | A1 | 9/2005 | Petite et al. | 2007/0089440 | A1 | 4/2007 | Singh et al. | |
| 2005/0196285 | A1 | 9/2005 | Jayanth | 2007/0101750 | A1 | 5/2007 | Pham et al. | |
| 2005/0198063 | A1 | 9/2005 | Thomas et al. | 2007/0159978 | A1 | 7/2007 | Anglin et al. | |
| 2005/0201397 | A1 | 9/2005 | Petite | 2007/0186569 | A1 | 8/2007 | Street et al. | |
| 2005/0204756 | A1 | 9/2005 | Dobmeier et al. | 2007/0204635 | A1 | 9/2007 | Tanaka et al. | |
| 2005/0207741 | A1 | 9/2005 | Shah et al. | 2007/0204921 | A1 | 9/2007 | Alles | |
| 2005/0214148 | A1 | 9/2005 | Ogawa et al. | 2007/0205296 | A1 | 9/2007 | Bell et al. | |
| 2005/0222715 | A1 | 10/2005 | Ruhnke et al. | 2007/0229305 | A1 | 10/2007 | Bonicatto et al. | |
| 2005/0228607 | A1 | 10/2005 | Simons | 2007/0239894 | A1 | 10/2007 | Thind et al. | |
| 2005/0229612 | A1 | 10/2005 | Hrejsa et al. | 2008/0000241 | A1 | 1/2008 | Larsen et al. | |
| 2005/0229777 | A1 | 10/2005 | Brown et al. | 2008/0015797 | A1 | 1/2008 | Kates | |
| 2005/0232781 | A1 | 10/2005 | Herbert et al. | 2008/0016888 | A1 | 1/2008 | Kates | |
| 2005/0235660 | A1 | 10/2005 | Pham | 2008/0033674 | A1 | 2/2008 | Nikovski et al. | |
| 2005/0235661 | A1 | 10/2005 | Pham | 2008/0051945 | A1 | 2/2008 | Kates | |
| 2005/0235662 | A1 | 10/2005 | Pham | 2008/0058970 | A1 | 3/2008 | Perumalsamy et al. | |
| 2005/0235663 | A1 | 10/2005 | Pham | 2008/0078289 | A1 | 4/2008 | Sergi et al. | |
| 2005/0235664 | A1 | 10/2005 | Pham | 2008/0109185 | A1 | 5/2008 | Cheung et al. | |
| 2005/0247194 | A1 | 11/2005 | Kang et al. | 2008/0110189 | A1 | 5/2008 | Alston et al. | |
| 2005/0251293 | A1 | 11/2005 | Seigel | 2008/0114569 | A1 | 5/2008 | Seigel | |
| 2005/0252220 | A1 | 11/2005 | Street et al. | 2008/0121729 | A1 | 5/2008 | Gray | |
| 2005/0262856 | A1 | 12/2005 | Street et al. | 2008/0183424 | A1 | 7/2008 | Seem | |
| 2005/0262923 | A1 | 12/2005 | Kates | 2008/0186898 | A1 | 8/2008 | Petite | |
| 2005/0279110 | A1 | 12/2005 | Zeng et al. | 2008/0209925 | A1 | 9/2008 | Pham | |
| 2006/0010898 | A1 | 1/2006 | Suharno et al. | 2008/0216494 | A1 | 9/2008 | Pham et al. | |
| 2006/0015777 | A1 | 1/2006 | Loda | 2008/0216495 | A1 | 9/2008 | Kates | |
| 2006/0020426 | A1 | 1/2006 | Singh | 2008/0223051 | A1 | 9/2008 | Kates | |
| 2006/0021362 | A1 | 2/2006 | Sadegh et al. | 2008/0234869 | A1 | 9/2008 | Yonezawa et al. | |
| 2006/0032245 | A1 | 2/2006 | Kates | 2008/0315000 | A1* | 12/2008 | Gorthala B60H 1/00785 236/46 C | |
| 2006/0032246 | A1 | 2/2006 | Kates | 2008/0319688 | A1 | 12/2008 | Kim | |
| 2006/0032247 | A1 | 2/2006 | Kates | 2009/0007777 | A1 | 1/2009 | Cohen et al. | |
| 2006/0032248 | A1 | 2/2006 | Kates | 2009/0030555 | A1 | 1/2009 | Gray | |
| 2006/0032379 | A1 | 2/2006 | Kates | 2009/0037142 | A1 | 2/2009 | Kates | |
| 2006/0036349 | A1 | 2/2006 | Kates | 2009/0038010 | A1 | 2/2009 | Ma et al. | |
| 2006/0041335 | A9 | 2/2006 | Rossi et al. | 2009/0055465 | A1 | 2/2009 | DePue et al. | |
| 2006/0042276 | A1 | 3/2006 | Doll et al. | 2009/0057424 | A1 | 3/2009 | Sullivan et al. | |
| 2006/0071089 | A1 | 4/2006 | Kates | 2009/0057428 | A1 | 3/2009 | Gaedelmann et al. | |
| 2006/0071666 | A1 | 4/2006 | Unsworth et al. | 2009/0068947 | A1 | 3/2009 | Petite | |
| 2006/0074917 | A1 | 4/2006 | Chand et al. | 2009/0071175 | A1 | 3/2009 | Pham | |
| 2006/0097063 | A1 | 5/2006 | Zeevi | 2009/0072985 | A1 | 3/2009 | Patel et al. | |
| 2006/0098576 | A1 | 5/2006 | Brownrigg et al. | 2009/0093916 | A1 | 4/2009 | Parsonnet et al. | |
| 2006/0117773 | A1 | 6/2006 | Street et al. | 2009/0094998 | A1 | 4/2009 | McSweeney et al. | |
| 2006/0123807 | A1 | 6/2006 | Sullivan et al. | 2009/0096605 | A1 | 4/2009 | Petite et al. | |
| 2006/0129339 | A1 | 6/2006 | Bruno | 2009/0106601 | A1 | 4/2009 | Ngai et al. | |
| 2006/0130500 | A1 | 6/2006 | Gauthier et al. | 2009/0112672 | A1 | 4/2009 | Flamig et al. | |
| 2006/0137364 | A1 | 6/2006 | Braun et al. | 2009/0114309 | A1* | 5/2009 | Sakai F25B 45/00 141/1 | |
| 2006/0137368 | A1* | 6/2006 | Kang F25B 45/00 62/149 | 2009/0119036 | A1 | 5/2009 | Jayanth et al. | |
| 2006/0138866 | A1 | 6/2006 | Bergmann et al. | 2009/0125151 | A1 | 5/2009 | Steinberg et al. | |
| 2006/0140209 | A1 | 6/2006 | Cassiolato et al. | 2009/0125257 | A1 | 5/2009 | Jayanth et al. | |
| 2006/0151037 | A1 | 7/2006 | Lepola et al. | 2009/0140880 | A1 | 6/2009 | Flen et al. | |
| | | | | 2009/0151374 | A1 | 6/2009 | Kasahara | |
| | | | | 2009/0187281 | A1 | 7/2009 | Kates | |

(56)

References Cited

U.S. PATENT DOCUMENTS

| | | | | | | | |
|--------------|----|---------|---------------------|--------------|----|---------|-------------------|
| 2009/0215424 | A1 | 8/2009 | Petite | 2012/0065783 | A1 | 3/2012 | Fadell et al. |
| 2009/0229469 | A1 | 9/2009 | Campbell et al. | 2012/0065935 | A1 | 3/2012 | Steinberg et al. |
| 2009/0241570 | A1 | 10/2009 | Kuribayashi et al. | 2012/0066168 | A1 | 3/2012 | Fadell et al. |
| 2009/0296832 | A1 | 12/2009 | Hunt | 2012/0075092 | A1 | 3/2012 | Petite et al. |
| 2009/0324428 | A1 | 12/2009 | Tolbert, Jr. et al. | 2012/0092154 | A1 | 4/2012 | Petite |
| 2010/0006042 | A1 | 1/2010 | Pitonyak et al. | 2012/0125559 | A1 | 5/2012 | Fadell et al. |
| 2010/0011962 | A1 | 1/2010 | Totsugi | 2012/0125592 | A1 | 5/2012 | Fadell et al. |
| 2010/0017465 | A1 | 1/2010 | Brownrigg et al. | 2012/0126019 | A1 | 5/2012 | Warren et al. |
| 2010/0039984 | A1 | 2/2010 | Brownrigg | 2012/0126020 | A1 | 5/2012 | Filson et al. |
| 2010/0044449 | A1 | 2/2010 | Tessier | 2012/0126021 | A1 | 5/2012 | Warren et al. |
| 2010/0070084 | A1 | 3/2010 | Steinberg et al. | 2012/0128025 | A1 | 5/2012 | Huppi et al. |
| 2010/0070234 | A1 | 3/2010 | Steinberg et al. | 2012/0130546 | A1 | 5/2012 | Matas et al. |
| 2010/0070666 | A1 | 3/2010 | Brindle | 2012/0130547 | A1 | 5/2012 | Fadell et al. |
| 2010/0078493 | A1 | 4/2010 | Alles | 2012/0130548 | A1 | 5/2012 | Fadell et al. |
| 2010/0081357 | A1 | 4/2010 | Alles | 2012/0130679 | A1 | 5/2012 | Fadell et al. |
| 2010/0081372 | A1 | 4/2010 | Alles | 2012/0131504 | A1 | 5/2012 | Fadell et al. |
| 2010/0089076 | A1 | 4/2010 | Schuster et al. | 2012/0143528 | A1 | 6/2012 | Kates |
| 2010/0102136 | A1 | 4/2010 | Hadzidedic et al. | 2012/0179300 | A1 | 7/2012 | Warren et al. |
| 2010/0111709 | A1 | 5/2010 | Jayanth | 2012/0186774 | A1 | 7/2012 | Matsuoka et al. |
| 2010/0168924 | A1 | 7/2010 | Tessier et al. | 2012/0191257 | A1 | 7/2012 | Corcoran et al. |
| 2010/0169030 | A1 | 7/2010 | Parlos | 2012/0199660 | A1 | 8/2012 | Warren et al. |
| 2010/0179703 | A1 | 7/2010 | Singh et al. | 2012/0203379 | A1 | 8/2012 | Sloo et al. |
| 2010/0191487 | A1 | 7/2010 | Rada et al. | 2012/0221150 | A1 | 8/2012 | Arensmeier |
| 2010/0194582 | A1 | 8/2010 | Petite | 2012/0229521 | A1 | 9/2012 | Hales, IV et al. |
| 2010/0214709 | A1 | 8/2010 | Hall et al. | 2012/0232969 | A1 | 9/2012 | Fadell et al. |
| 2010/0217550 | A1 | 8/2010 | Crabtree et al. | 2012/0233478 | A1 | 9/2012 | Mucignat et al. |
| 2010/0250054 | A1 | 9/2010 | Petite | 2012/0239207 | A1 | 9/2012 | Fadell et al. |
| 2010/0257410 | A1 | 10/2010 | Cottrell et al. | 2012/0239221 | A1 | 9/2012 | Mighdoll et al. |
| 2010/0262299 | A1 | 10/2010 | Cheung et al. | 2012/0245968 | A1 | 9/2012 | Beaulieu et al. |
| 2010/0265909 | A1 | 10/2010 | Petite et al. | 2012/0248210 | A1 | 10/2012 | Warren et al. |
| 2010/0280667 | A1 | 11/2010 | Steinberg | 2012/0248211 | A1 | 10/2012 | Warren et al. |
| 2010/0282857 | A1 | 11/2010 | Steinberg | 2012/0260804 | A1 | 10/2012 | Kates |
| 2010/0287489 | A1 | 11/2010 | Alles | 2012/0265491 | A1 | 10/2012 | Drummy |
| 2010/0293397 | A1 | 11/2010 | Pham et al. | 2012/0265586 | A1 | 10/2012 | Mammone |
| 2010/0305718 | A1 | 12/2010 | Clark et al. | 2012/0271673 | A1 | 10/2012 | Riley |
| 2010/0308119 | A1 | 12/2010 | Steinberg et al. | 2012/0291629 | A1 | 11/2012 | Tylutki et al. |
| 2010/0312881 | A1 | 12/2010 | Davis et al. | 2012/0318135 | A1 | 12/2012 | Hoglund et al. |
| 2010/0318227 | A1 | 12/2010 | Steinberg et al. | 2012/0318137 | A1 | 12/2012 | Ragland et al. |
| 2010/0330985 | A1 | 12/2010 | Addy | 2013/0066479 | A1 | 3/2013 | Shetty et al. |
| 2011/0004350 | A1 | 1/2011 | Cheifetz et al. | 2013/0156607 | A1 | 6/2013 | Jayanth |
| 2011/0022429 | A1 | 1/2011 | Yates et al. | 2013/0166231 | A1 | 6/2013 | Jayanth et al. |
| 2011/0023045 | A1 | 1/2011 | Yates et al. | 2013/0174588 | A1 | 7/2013 | Pham |
| 2011/0023945 | A1 | 2/2011 | Hayashi et al. | 2013/0176649 | A1 | 7/2013 | Wallis et al. |
| 2011/0040785 | A1 | 2/2011 | Steenberg et al. | 2013/0182285 | A1 | 7/2013 | Matsuhara et al. |
| 2011/0042541 | A1 | 2/2011 | Spencer et al. | 2013/0287063 | A1 | 10/2013 | Kates |
| 2011/0045454 | A1 | 2/2011 | McManus et al. | 2013/0294933 | A1 | 11/2013 | Pham |
| 2011/0054842 | A1 | 3/2011 | Kates | 2014/0000290 | A1 | 1/2014 | Kates |
| 2011/0071960 | A1 | 3/2011 | Singh | 2014/0000291 | A1 | 1/2014 | Kates |
| 2011/0077896 | A1 | 3/2011 | Steinberg et al. | 2014/0000292 | A1 | 1/2014 | Kates |
| 2011/0083450 | A1 | 4/2011 | Turner et al. | 2014/0000293 | A1 | 1/2014 | Kates |
| 2011/0102159 | A1 | 5/2011 | Olson et al. | 2014/0000294 | A1 | 1/2014 | Kates |
| 2011/0103460 | A1 | 5/2011 | Bonicatto | 2014/0012422 | A1 | 1/2014 | Kates |
| 2011/0106471 | A1 | 5/2011 | Curtis et al. | 2014/0069121 | A1 | 3/2014 | Pham |
| 2011/0112814 | A1 | 5/2011 | Clark | 2014/0074730 | A1 | 3/2014 | Arensmeier et al. |
| 2011/0118905 | A1 | 5/2011 | Mylaraswamy et al. | 2014/0084836 | A1 | 3/2014 | Pham et al. |
| 2011/0121952 | A1 | 5/2011 | Bonicatto et al. | 2014/0229014 | A1 | 8/2014 | Pham et al. |
| 2011/0144932 | A1 | 6/2011 | Alles | 2014/0260342 | A1 | 9/2014 | Pham |
| 2011/0144944 | A1 | 6/2011 | Pham | 2014/0260390 | A1 | 9/2014 | Pham |
| 2011/0166828 | A1 | 7/2011 | Steinberg et al. | 2014/0262134 | A1 | 9/2014 | Arensmeier et al. |
| 2011/0181438 | A1 | 7/2011 | Millstein et al. | 2014/0266755 | A1 | 9/2014 | Arensmeier et al. |
| 2011/0184563 | A1 | 7/2011 | Foslien et al. | 2014/0297208 | A1 | 10/2014 | Arensmeier |
| 2011/0185895 | A1 | 8/2011 | Freen | 2014/0299289 | A1 | 10/2014 | Alsalem et al. |
| 2011/0190910 | A1 | 8/2011 | Lombard et al. | 2015/0135748 | A1 | 5/2015 | Alsalem et al. |
| 2011/0212700 | A1 | 9/2011 | Petite | 2015/0155701 | A1 | 6/2015 | Wallis et al. |
| 2011/0218957 | A1 | 9/2011 | Coon et al. | 2015/0261230 | A1 | 9/2015 | Kates |
| 2011/0264324 | A1 | 10/2011 | Petite et al. | 2015/0367463 | A1 | 12/2015 | Pham |
| 2011/0264409 | A1 | 10/2011 | Jayanth et al. | 2016/0076536 | A1 | 3/2016 | Jayanth et al. |
| 2011/0290893 | A1 | 12/2011 | Steinberg | 2016/0223238 | A1 | 8/2016 | Kates |
| 2011/0307103 | A1 | 12/2011 | Cheung et al. | 2016/0226416 | A1 | 8/2016 | Pham et al. |
| 2011/0309953 | A1 | 12/2011 | Petite et al. | 2017/0179709 | A1 | 6/2017 | Wallis et al. |
| 2011/0310929 | A1 | 12/2011 | Petite et al. | 2017/0266769 | A1 | 9/2017 | Pham |
| 2011/0315019 | A1 | 12/2011 | Lyon et al. | 2017/0308072 | A1 | 10/2017 | Arensmeier |
| 2011/0320050 | A1 | 12/2011 | Petite et al. | 2018/0045445 | A1 | 2/2018 | Pham |
| 2012/0005590 | A1 | 1/2012 | Lombard et al. | 2018/0129233 | A1 | 5/2018 | Kates |
| 2012/0054242 | A1 | 3/2012 | Ferrara et al. | | | | |

FOREIGN PATENT DOCUMENTS

| | | | |
|----|---------|----|---------|
| CA | 2528778 | A1 | 12/2004 |
| CA | 2567264 | A1 | 7/2007 |

(56)

References Cited

FOREIGN PATENT DOCUMENTS

| | | | | | | | |
|----|-----------|----|---------|----|---------------|----|---------|
| CH | 173493 | A | 11/1934 | GB | 2116635 | A | 9/1983 |
| CN | 1133425 | A | 10/1996 | GB | 2229295 | A | 9/1990 |
| CN | 1169619 | A | 1/1998 | GB | 2347217 | A | 8/2000 |
| CN | 1297522 | A | 5/2001 | JP | 56010639 | A | 2/1981 |
| CN | 1354347 | A | 6/2002 | JP | 59145392 | A | 8/1984 |
| CN | 1356472 | A | 7/2002 | JP | 61046485 | A | 3/1986 |
| CN | 1654893 | A | 8/2005 | JP | 62116844 | A | 5/1987 |
| CN | 1742427 | A | 3/2006 | JP | 63061783 | A | 3/1988 |
| CN | 1906453 | A | 1/2007 | JP | 63302238 | A | 12/1988 |
| CN | 1922445 | A | 2/2007 | JP | 01014554 | A | 1/1989 |
| CN | 101048713 | A | 10/2007 | JP | 02110242 | A | 4/1990 |
| CN | 101124436 | A | 2/2008 | JP | 02294580 | A | 12/1990 |
| CN | 101156033 | A | 4/2008 | JP | 04080578 | A | 3/1992 |
| CN | 101270908 | A | 9/2008 | JP | 06058273 | A | 3/1994 |
| CN | 101361244 | A | 2/2009 | JP | 08021675 | A | 1/1996 |
| CN | 101466193 | A | 6/2009 | JP | 08087229 | A | 4/1996 |
| CN | 101506600 | A | 8/2009 | JP | 08261541 | A | 10/1996 |
| CN | 101802521 | A | 8/2010 | JP | 08284842 | A | 10/1996 |
| CN | 101821693 | A | 9/2010 | JP | 2000350490 | A | 12/2000 |
| CN | 102354206 | A | 2/2012 | JP | 2002155868 | A | 5/2002 |
| DE | 842351 | C | 6/1952 | JP | 2003018883 | A | 1/2003 |
| DE | 764179 | C | 4/1953 | JP | 2003176788 | A | 6/2003 |
| DE | 1144461 | B | 2/1963 | JP | 2004316504 | A | 11/2004 |
| DE | 1403516 | A1 | 10/1968 | JP | 2005188790 | A | 7/2005 |
| DE | 1403467 | A1 | 10/1969 | JP | 2005241089 | A | 9/2005 |
| DE | 3118638 | A1 | 5/1982 | JP | 2005345096 | A | 12/2005 |
| DE | 3133502 | A1 | 6/1982 | JP | 2006046219 | A | 2/2006 |
| DE | 3508353 | A1 | 9/1985 | JP | 2006046519 | A | 2/2006 |
| DE | 3422398 | A1 | 12/1985 | JP | 2006274807 | A | 10/2006 |
| DE | 29723145 | U1 | 4/1998 | JP | 2009002651 | A | 1/2009 |
| EP | 0008524 | A1 | 3/1980 | JP | 2009229184 | A | 10/2009 |
| EP | 0060172 | A1 | 9/1982 | JP | 2010048433 | A | 3/2010 |
| EP | 0085246 | A1 | 8/1983 | KR | 1019980036844 | A | 8/1998 |
| EP | 0124603 | A1 | 11/1984 | KR | 1020000000261 | A | 1/2000 |
| EP | 0254253 | A2 | 1/1988 | KR | 1020000025265 | | 5/2000 |
| EP | 0346152 | A2 | 12/1989 | KR | 1020020041977 | | 6/2002 |
| EP | 0351272 | A1 | 1/1990 | KR | 20030042857 | A | 6/2003 |
| EP | 0351833 | A2 | 1/1990 | KR | 1020040021281 | | 3/2004 |
| EP | 0355255 | A2 | 2/1990 | KR | 1020060020353 | | 3/2006 |
| EP | 0361394 | A2 | 4/1990 | RU | 30009 | U1 | 6/2003 |
| EP | 0398436 | A1 | 11/1990 | RU | 55218 | U1 | 7/2006 |
| EP | 0410330 | A2 | 1/1991 | WO | WO-8601262 | A1 | 2/1986 |
| EP | 0419857 | A2 | 4/1991 | WO | WO-8703988 | A1 | 7/1987 |
| EP | 0432085 | A2 | 6/1991 | WO | WO-8705097 | A1 | 8/1987 |
| EP | 0453302 | A1 | 10/1991 | WO | WO-8802527 | A1 | 4/1988 |
| EP | 0479421 | A1 | 4/1992 | WO | WO-8806703 | A1 | 9/1988 |
| EP | 0557023 | A1 | 8/1993 | WO | WO-9718636 | A2 | 5/1997 |
| EP | 0579374 | A1 | 1/1994 | WO | WO-9748161 | A1 | 12/1997 |
| EP | 0660213 | A2 | 6/1995 | WO | WO-9917066 | A1 | 4/1999 |
| EP | 0747598 | A2 | 12/1996 | WO | WO-9961847 | A1 | 12/1999 |
| EP | 0877462 | A2 | 11/1998 | WO | WO-9965681 | A1 | 12/1999 |
| EP | 0982497 | A1 | 3/2000 | WO | WO-0021047 | A1 | 4/2000 |
| EP | 1008816 | A2 | 6/2000 | WO | WO-0051223 | A1 | 8/2000 |
| EP | 1087142 | A2 | 3/2001 | WO | WO-0169147 | A1 | 9/2001 |
| EP | 1087184 | A2 | 3/2001 | WO | WO-0214968 | A1 | 2/2002 |
| EP | 1138949 | A2 | 10/2001 | WO | WO-0249178 | A2 | 6/2002 |
| EP | 1139037 | A1 | 10/2001 | WO | WO-0275227 | A1 | 9/2002 |
| EP | 1187021 | A2 | 3/2002 | WO | WO-02090840 | A2 | 11/2002 |
| EP | 1209427 | A1 | 5/2002 | WO | WO-02090913 | A1 | 11/2002 |
| EP | 1241417 | A1 | 9/2002 | WO | WO-02090914 | A1 | 11/2002 |
| EP | 1245912 | A2 | 10/2002 | WO | WO-03031996 | A1 | 4/2003 |
| EP | 1245913 | A1 | 10/2002 | WO | WO-03090000 | A1 | 10/2003 |
| EP | 1393034 | A1 | 3/2004 | WO | WO-04049088 | A1 | 6/2004 |
| EP | 1435002 | A1 | 7/2004 | WO | WO-2005022049 | A2 | 3/2005 |
| EP | 1487077 | A2 | 12/2004 | WO | WO-2005065355 | A2 | 7/2005 |
| EP | 1541869 | A1 | 6/2005 | WO | WO-05073686 | A1 | 8/2005 |
| EP | 2180270 | A1 | 4/2010 | WO | WO-2005108882 | A2 | 11/2005 |
| FR | 2472862 | A1 | 7/1981 | WO | WO-06023075 | A2 | 3/2006 |
| FR | 2582430 | A1 | 11/1986 | WO | WO-2006025880 | A1 | 3/2006 |
| FR | 2589561 | A1 | 5/1987 | WO | WO-2006091521 | A2 | 8/2006 |
| FR | 2628558 | A1 | 9/1989 | WO | WO-2008010988 | A1 | 1/2008 |
| FR | 2660739 | A1 | 10/1991 | WO | WO-2008079108 | A1 | 7/2008 |
| GB | 2062919 | A | 5/1981 | WO | WO-08144864 | A1 | 12/2008 |
| GB | 2064818 | A | 6/1981 | WO | WO-2009058356 | A1 | 5/2009 |
| GB | 2075774 | A | 11/1981 | WO | WO-2009061370 | A1 | 5/2009 |
| | | | | WO | WO-10138831 | A2 | 12/2010 |

(56)

References Cited

FOREIGN PATENT DOCUMENTS

| | | |
|----|------------------|--------|
| WO | WO-11069170 A1 | 6/2011 |
| WO | WO-12092625 A2 | 7/2012 |
| WO | WO-2012118550 A1 | 9/2012 |

OTHER PUBLICATIONS

“Air Conditioning Equipment and Diagnostic Primer,” Field Diagnostic Services, Inc., Sep. 9, 2002.

“Manual for Freezing and Air Conditioning Technology,” Fan Jili, Liaoning Science and Technology Press, Sep. 1995 (cited in First Office Action issued by the Chinese Patent Office regarding Application No. 200780030810.X dated Dec. 25, 2009).

“Product Performance Introduction of York Company,” cited in First Office Action from the Patent Office of the People’s Republic of China dated Jun. 29, 2007 regarding Application No. 200510005907.8, including translation by CCPIT Patent and Trademark Law Office.

“Small-type Freezing and Air Conditioning Operation,” Chinese State Economy and Trading Committee, China Meteorological Press, Mar. 2003 (cited in First Office Action issued by the Chinese Patent Office regarding Application No. 200780030810.X dated Dec. 25, 2009).

About CABA: CABA eBulletin, <http://www.caba.org/aboutus/ebulletin/issue17/domosys.html>, 2 pages, dated Sep. 22, 2004.

Advanced Utility Metering: Period of Performance, Subcontractor Report, National Renewable Energy Laboratory, Sep. 2003, 59 pages.

Advisory Action and Examiner-Initiated Interview Summary regarding U.S. Appl. No. 13/770,479, dated May 23, 2017.

Advisory Action and Interview Summary regarding U.S. Appl. No. 13/407,180, dated May 27, 2015.

Advisory Action Before the Filing of an Appeal Brief regarding U.S. Appl. No. 11/098,575, dated Nov. 16, 2009.

Advisory Action Before the Filing of an Appeal Brief regarding U.S. Appl. No. 11/098,575, dated Sep. 28, 2009.

Advisory Action Before the Filing of an Appeal Brief regarding U.S. Appl. No. 09/977,552, dated Nov. 10, 2005.

Advisory Action from related U.S. Appl. No. 13/784,890 dated Mar. 14, 2014.

Advisory Action regarding U.S. Appl. No. 12/261,643, dated Nov. 22, 2013.

Advisory Action regarding U.S. Appl. No. 13/269,188, dated Apr. 13, 2015.

Advisory Action regarding U.S. Appl. No. 14/080,473, dated Jan. 30, 2017.

Advisory Action regarding U.S. Appl. No. 14/193,568, dated Aug. 10, 2016.

Advisory Action regarding U.S. Appl. No. 14/208,636, dated Mar. 23, 2017.

Advisory Action regarding U.S. Appl. No. 14/212,632, dated Feb. 9, 2016.

Advisory Action regarding U.S. Appl. No. 14/212,632, dated Mar. 8, 2016.

Advisory Action regarding U.S. Appl. No. 11/214,179, dated Aug. 28, 2009.

Applicant-Initiated Interview Summary and Advisory Action regarding U.S. Appl. No. 13/369,067, dated Jul. 23, 2015.

Applicant-Initiated Interview Summary regarding U.S. Appl. No. 13/770,479, dated Dec. 9, 2016.

Applicant-Initiated Interview Summary regarding U.S. Appl. No. 14/212,632, dated Sep. 2, 2015.

BChydro, “Power Factor” Guides to Energy Management: The GEM Series, Oct. 1999.

Building Control Unit (BCU) Installation and Operation Manual, Computer Process Controls, Jan. 28, 1998, 141 pages.

Case Studies: Automated Meter Reading and Load Shed System, <http://groupalpha.com/CaseStudies2.html>, Aug. 23, 2004, 1 page.

Communication from European Patent Office concerning Substantive Examination regarding European Patent Application No. 06790063.9, dated Jun. 6, 2011.

Corrected Notice of Allowability regarding U.S. Appl. No. 14/080,473 dated Dec. 27, 2017.

Cost Cutting Techniques Used by the Unscrupulous, <http://www.kellyshvac.com/howto.html>, Oct. 7, 2004, 3 pages.

Einstein RX-300 Refrigeration Controller Installation and Operation Manual, Computer Process Controls, Apr. 1, 1998, 329 pages.

Election/Restriction Requirement regarding U.S. Appl. No. 09/977,552, dated Jan. 25, 2007.

European Search Report for Application No. EP 01 30 1752, dated Mar. 26, 2002.

European Search Report for Application No. EP 02 25 1531, dated Sep. 30, 2002.

European Search Report for Application No. EP 04 81 5853, dated Jul. 17, 2007, 2 Pages.

European Search Report for Application No. EP 06 02 6263, dated Jul. 17, 2007, 4 Pages.

European Search Report for Application No. EP 12 182 243.1, dated Oct. 29, 2012.

European Search Report for EP 01 30 7547; dated Feb. 20, 2002; 1 Page.

European Search Report for EP 02 25 0266; dated May 17, 2002; 3 Pages.

European Search Report for EP 02 72 9050, dated Jun. 17, 2004, 2 Pages.

European Search Report for EP 82306809.3; dated Apr. 28, 1983; 1 Page.

European Search Report for EP 91 30 3518; dated Jul. 22, 1991; 1 Page.

European Search Report for EP 93 30 4470; dated Oct. 26, 1993; 1 Page.

European Search Report for EP 94 30 3484; dated Apr. 3, 1997; 1 Page.

European Search Report for EP 96 30 4219; dated Dec. 1, 1998; 2 Pages.

European Search Report for EP 98 30 3525; dated May 28, 1999; 2 Pages.

European Search Report for EP 99 30 6052; dated Dec. 28, 1999; 3 Pages.

European Search Report regarding Application No. 04022784.5-2315 / 1500821, dated Aug. 14, 2012.

European Search Report regarding Application No. 07811712.4-1608 / 2069638 PCT/US2007019563, dated Jan. 7, 2014.

European Search Report regarding Application No. EP02729051, dated Feb. 17, 2005.

Examination Report received from Australian Government IP Australia dated Oct. 29, 2009 regarding Patent Application No. 2008202088.

Examiner Interview regarding U.S. Appl. No. 11/256,641, dated Sep. 16, 2008.

Examiner Interview Summary regarding U.S. Appl. No. 11/394,380, dated Jul. 29, 2010.

Examiner Interview Summary regarding U.S. Appl. No. 10/940,877, dated Dec. 8, 2008.

Examiner Interview Summary regarding U.S. Appl. No. 10/940,877, dated Mar. 2, 2007.

Examiner Interview Summary regarding U.S. Appl. No. 10/940,877, dated Mar. 25, 2008.

Examiner’s Answer from related U.S. Appl. No. 13/784,890 dated Jul. 3, 2014.

Examiner’s Answer regarding U.S. Appl. No. 09/977,552, dated Dec. 17, 2009.

Examiner’s Answer regarding U.S. Appl. No. 12/943,626, dated Sep. 19, 2017.

Examiner’s First Report on Australian Patent Application No. 2002259066, dated Mar. 1, 2006.

Examiner’s First Report on Australian Patent Application No. 2007292917 dated Jan. 10, 2012.

Examiner’s Report No. 1 regarding Australian Patent Application No. 2013202431, dated Nov. 25, 2014.

Examiner’s Report No. 2 regarding Australian Patent Application No. 2008325240, dated Mar. 5, 2012.

(56)

References Cited

OTHER PUBLICATIONS

- Examiner-Initiated Interview Summary regarding U.S. Appl. No. 11/214,179, dated Dec. 11, 2009.
- Extended European Search Report regarding Application No. 07796879.0-1602 / 2041501 PCT/US2007016135, dated Jul. 14, 2014.
- Extended European Search Report regarding Application No. 12182243.1-2311, dated Oct. 29, 2012.
- Extended European Search Report regarding European Application No. 08845689.2-1608/2207964, dated Jun. 19, 2015.
- Extended European Search Report regarding European Application No. 08848538.8-1608 / 2220372, dated Jun. 19, 2015.
- Faramarzi et al., "Performance Evaluation of Rooftop Air Conditioning Units at High Ambient Temperatures," 2004 ACEEE Summer Study on Energy Efficiency in Buildings—http://aceee.org/files/proceedings/2004/data/papers/SSO4_Panel3_Paper05.pdf.
- Final Office Action and Interview Summary regarding U.S. Appl. No. 13/407,180, dated Mar. 13, 2015.
- Final Office Action for U.S. Appl. No. 13/770,123 dated Dec. 22, 2014.
- Final Office Action for U.S. Appl. No. 11/850,846, dated Aug. 13, 2012.
- Final Office Action for U.S. Appl. No. 12/054,011, dated Jun. 30, 2011.
- Final Office Action from related U.S. Appl. No. 13/269,188 dated May 23, 2013; 11 pages.
- Final Office Action from related U.S. Appl. No. 13/369,067 dated May 1, 2014; 19 pages.
- Final Office Action from related U.S. Appl. No. 13/767,479 dated Mar. 14, 2014; 6 pages.
- Final Office Action from related U.S. Appl. No. 13/836,043 dated Mar. 12, 2014; 5 pages.
- Final Office Action dated Dec. 7, 2010 for U.S. Appl. No. 12/054,011.
- Final Office Action regarding U.S. Appl. No. 11/497,579, dated May 14, 2010.
- Final Office Action regarding U.S. Appl. No. 11/497,644, dated Dec. 22, 2010.
- Final Office Action regarding U.S. Appl. No. 11/850,846, dated Jan. 17, 2014.
- Final Office Action regarding U.S. Appl. No. 13/269,188, dated Feb. 10, 2015.
- Final Office Action regarding U.S. Appl. No. 13/767,479, dated Feb. 6, 2015.
- Final Office Action regarding U.S. Appl. No. 13/770,123, dated Nov. 15, 2013.
- Final Office Action regarding U.S. Appl. No. 13/784,890, dated Dec. 30, 2013.
- Final Office Action regarding U.S. Appl. No. 13/932,611, dated May 28, 2014.
- Final Office Action regarding U.S. Appl. No. 14/244,967, dated Feb. 12, 2016.
- Final Office Action regarding U.S. Appl. No. 13/770,479, dated Sep. 4, 2015.
- Final Office Action regarding U.S. Appl. No. 15/583,942 dated Apr. 18, 2018.
- Final Office Action regarding U.S. Appl. No. 11/214,179, dated Jul. 21, 2011.
- Final Office Action regarding U.S. Appl. No. 09/977,552, dated Oct. 22, 2008.
- Final Office Action regarding U.S. Appl. No. 09/977,552, dated Apr. 26, 2004.
- Final Office Action regarding U.S. Appl. No. 09/977,552, dated May 13, 2005.
- Final Office Action regarding U.S. Appl. No. 09/977,552, dated Jun. 18, 2003.
- Final Office Action regarding U.S. Appl. No. 09/977,552, dated Jul. 23, 2007.
- Final Office Action regarding U.S. Appl. No. 10/061,964, dated Mar. 8, 2004.
- Final Office Action regarding U.S. Appl. No. 10/940,877, dated Nov. 13, 2007.
- Final Office Action regarding U.S. Appl. No. 10/940,877, dated Apr. 27, 2009.
- Final Office Action regarding U.S. Appl. No. 10/940,877, dated May 2, 2006.
- Final Office Action regarding U.S. Appl. No. 11/098,575, dated Jun. 17, 2010.
- Final Office Action regarding U.S. Appl. No. 11/214,179, dated May 29, 2009.
- Final Office Action regarding U.S. Appl. No. 11/256,641, dated Feb. 2, 2009.
- Final Office Action regarding U.S. Appl. No. 11/337,918, dated Feb. 17, 2011.
- Final Office action regarding U.S. Appl. No. 11/337,918, dated Feb. 4, 2010.
- Final Office Action regarding U.S. Appl. No. 12/261,643, dated Jun. 27, 2012.
- Final Office Action regarding U.S. Appl. No. 12/261,643, dated Sep. 16, 2013.
- Final Office Action regarding U.S. Appl. No. 12/261,643, dated Jul. 7, 2011.
- First Chinese Office Action regarding Application No. 201380005300.2, dated Apr. 30, 2015. Translation provided by Unitalen Attorneys at Law.
- First Examination Communication regarding European Application No. EP02729051.9, dated Dec. 23, 2005.
- First Examination Report regarding Australian Patent Application No. 20110319488, dated Jan. 10, 2013.
- First Examination Report regarding Australian Patent Application No. 2012241185, dated Sep. 27, 2013.
- First Office Action from the Patent Office of the People's Republic of China dated Jun. 8, 2007, Application No. 200480027753.6 and Translation provided by CCPIT.
- First Office Action from the Patent Office of the People's Republic of China regarding Application No. 200510005907.8, dated Jun. 29, 2007.
- First Office Action from the State Intellectual Property Office of the People's Republic of China regarding Chinese Patent Application No. 200890100287.3, dated Oct. 25, 2010. Translation provided by Unitalen Attorneys at Law.
- First Office Action issued by the Chinese Patent Office for Application No. 200480015875.3, dated Sep. 5, 2008.
- First Office Action issued by the Chinese Patent Office dated May 30, 2008 regarding Application No. 200580013451.8, 8 Pages. Translation provided by CCPIT Patent and Trademark Law Office.
- First Office Action issued by the Chinese Patent Office regarding Application No. 200780030810.X dated Dec. 25, 2009.
- First Office Action received from the Chinese Patent Office dated Feb. 2, 2007 regarding Application No. 200480011463.2, translated by CCPIT Patent and Trademark Law Office.
- First Office Action regarding Canadian Patent Application No. 2,777,349, dated Jul. 19, 2013.
- First Office Action regarding Chinese Application No. 200880106319.5, dated May 25, 2011. English translation provided by Unitalen Attorneys at Law.
- First Office Action regarding Chinese Application No. 201610422700.4 dated Apr. 2, 2018. Translation provided by Unitalen Attorneys at Law.
- First Office Action regarding Chinese Patent Application No. 200780032977.X, dated Sep. 27, 2010. English translation provided by Unitalen Attorneys at Law.
- First Office Action regarding Chinese Patent Application No. 200910211779.0, dated May 3, 2012. English translation provided by Unitalen Attorneys at Law.
- First Office Action regarding Chinese Patent Application No. 201110349785.X, dated Nov. 21, 2013, and Search Report. English translation provided by Unitalen Attorneys at Law.
- First Office Action regarding Chinese Patent Application No. 201280010796.8, dated Sep. 14, 2015. Translation provided by Unitalen Attorneys at Law.
- First Official Report regarding Australian Patent Application No. 2007214381, dated Dec. 12, 2008.

(56)

References Cited

OTHER PUBLICATIONS

Flow & Level Measurement: Mass Flowmeters, <http://www.omega.com/literature/transactions/volume4/T9904-10-MASS.html>, 2001, 19 pages.

Fourth Office Action from the State Intellectual Property Office of People's Republic of China regarding Chinese Patent Application No. 200510005907.8, dated Dec. 8, 2011. Translation provided by Unitalen Attorneys at Law.

Fourth Office Action regarding Chinese Patent Application No. 200910211779.0, dated Jan. 6, 2014. English translation provided by Unitalen Attorneys at Law.

Frequently Asked Questions, <http://www.lipaedge.com/faq.asp>, Copyright © 2001, 5 pages.

Haiad et al., "EER & SEER as Predictors of Seasonal Energy Performance", Oct. 2004, Southern California Edison, http://www.doe2.com/download/DEER/SEER%2BProgThermostats/EER-SEER_CASE_ProjectSummary_Oct2004_V6a.pdf.

Home Comfort Zones, MyTemp Room-by-Room Zone Control, Nov. 2009.

Home Comfort Zones, MyTemp User Manual v4.3, May 2008.

Home Comfort Zones, Save Energy with MyTemp™ Zone Control, Dec. 2009.

Home Comfort Zones, Smart Controller™ MyTemp™ Room by Room Temperature Control and Energy Management, User Manual, Aug. 2007.

Honeywell, A7075A1000 HVAC Service Assistant, 2001.

Honeywell, Advanced Portable A/C Diagnostics, The HVAC Service Assistant, 2003.

Honeywell, Alerts and Delta T Diagnostics with Prestige® 2.0 IAQ Thermostat, 69-2678-02, Sep. 2011.

Honeywell, Excel 5000® System, Excel Building Supervisor—Integrated, 74-2034, Copyright © 1994, Rev. 11-94, 12 pages.

Honeywell, Excel 5000® System, Excel Building Supervisor, 74-2033-1, Copyright © 1996, Rev. Jun. 1996, 12 pages.

Honeywell, HVAC Service Assistant, TRGpro Palm™ OS Interface and HVAC Service Assistant A7075A1000, 2002.

Honeywell, Prestige System Installation Guide, THX9321/9421 Prestige® IAQ and RF EIM, 64-2490-03, Jul. 2011.

Honeywell, RedLINK™ Wireless Comfort Systems brochure, 50-1194, Sep. 2011.

HVAC Service Assistant, ACRx Efficiency and Capacity Estimating Technology, Field Diagnostics, 2004.

International Preliminary Examination Report regarding PCT/US02/13456, dated Sep. 15, 2003.

International Preliminary Report on Patentability for International Application No. PCT/US2008/009618, dated Mar. 24, 2010.

International Preliminary Report on Patentability for International Application No. PCT/US2008/012362, dated May 4, 2010.

International Preliminary Report on Patentability for International Application No. PCT/US2008/012364, dated May 4, 2010.

International Preliminary Report on Patentability regarding Application No. PCT/US2010/056315, dated May 24, 2012.

International Preliminary Report on Patentability regarding International Application No. PCT/US2007/019563 dated Mar. 10, 2009.

International Search Report and Written Opinion for related PCT Application No. PCT/US2014/028859, dated Aug. 22, 2014.

International Search Report and Written Opinion of the International Searching Authority regarding International Application No. PCT/US06/33702, dated Sep. 26, 2007.

International Search Report and Written Opinion of the ISA regarding International Application No. PCT/US2014/032927, ISA/KR dated Aug. 21, 2014.

International Search Report for International Application No. PCT/US04/43859, dated Mar. 2, 2006.

International Search Report for International Application No. PCT/US07/019563, dated Jan. 15, 2008, 3 Pages.

International Search Report for International Application No. PCT/US2007/016135 dated Oct. 22, 2007.

International Search Report for International Application No. PCT/US2008/009618, dated Dec. 8, 2008.

International Search Report for International Application No. PCT/US2008/012364 dated Mar. 13, 2009.

International Search Report for PCT/US02/13459; ISA/US; dated Sep. 19, 2002.

International Search Report for PCT/US2012/026973, dated Sep. 3, 2012, 5 pages.

International Search Report for PCT/US2013/061389, dated Jan. 22, 2014, 7 pages.

International Search Report from PCT/US2008/060900, dated Aug. 4, 2008, 6 pages.

International Search Report from related PCT Application No. PCT/US2014/028074 dated Jun. 19, 2014.

International Search Report regarding Application No. PCT/US2010/036601, dated Dec. 29, 2010.

International Search Report regarding Application No. PCT/US2010/056315, dated Jun. 28, 2011.

International Search Report regarding Application No. PCT/US2013/021161, dated May 8, 2013.

International Search Report, International App. No. PCT/US06/05917, dated Sep. 26, 2007.

International Search Report, International Application No. PCT/US02/13456, dated Aug. 22, 2002, 2 Pages.

International Search Report, International Application No. PCT/US04/13384; dated Aug. 1, 2004; 1 Page.

International Search Report, International Application No. PCT/US2004/027654, dated Aug. 25, 2004, 4 Pages.

International Search Report, International Application No. PCT/US2006/040964, dated Feb. 15, 2007, 2 Pages.

International Search Report; International Application No. PCT/IB96/01435; dated May 23, 1997; 1 Page.

International Search Report; International Application No. PCT/US98/18710; dated Jan. 26, 1999; 1 Page.

Interview Summary regarding U.S. Appl. No. 12/054,011, dated Jan. 30, 2012.

Interview Summary regarding U.S. Appl. No. 11/497,644, dated May 4, 2010.

Interview Summary regarding U.S. Appl. No. 13/269,188, dated Mar. 18, 2015.

Interview Summary regarding U.S. Appl. No. 13/369,067, dated Jul. 16, 2015.

Interview Summary regarding U.S. Appl. No. 13/407,180, dated Jun. 11, 2015.

Interview Summary regarding U.S. Appl. No. 13/770,479, dated Jun. 16, 2015.

Interview Summary regarding U.S. Appl. No. 13/770,479, dated May 10, 2017.

Interview Summary regarding U.S. Appl. No. 13/770,479, dated Nov. 25, 2015.

Interview Summary regarding U.S. Appl. No. 14/209,415, dated Jun. 20, 2016.

Interview Summary regarding U.S. Appl. No. 14/617,451, dated Jul. 28, 2016.

Interview Summary regarding U.S. Appl. No. 11/098,582, dated Apr. 27, 2010.

Interview Summary regarding U.S. Appl. No. 11/214,179, dated Jan. 30, 2009.

Interview Summary regarding U.S. Appl. No. 11/497,579, dated Jul. 15, 2010.

Invitation to Indicate Claims to be Searched regarding European Patent Application No. 07 796 879.0, dated Feb. 20, 2013.

Issue Notification regarding U.S. Appl. No. 11/214,179, dated Mar. 14, 2012.

Jeffus, Larry, "Refrigeration and Air Conditioning: An Introduction to HVAC/R," Appendix C, pp. 1060-1063, Copyright 2004.

Jeffus, Larry, "Refrigeration and Air Conditioning: An Introduction to HVAC/R," Section II, Chapter 4, pp. 176-201, Copyright 2004.

Jeffus, Larry, "Refrigeration and Air Conditioning: An Introduction to HVAC/R," Section II, Chapter 5, pp. 239-245, Copyright 2004.

Jeffus, Larry, "Refrigeration and Air Conditioning: An Introduction to HVAC/R," Section II, Chapter 6, p. 322, Copyright 2004.

Jeffus, Larry, "Refrigeration and Air Conditioning: An Introduction to HVAC/R," Section IV, Chapter 9, pp. 494-504, Copyright 2004.

(56)

References Cited

OTHER PUBLICATIONS

- K. A. Manske et al.; *Evaporative Condenser Control in Industrial Refrigeration Systems*; University of Wisconsin—Madison, Mechanical Engineering Department; *International Journal of Refrigeration*, vol. 24, No. 7; pp. 676-691; 2001, 21 pages.
- Kim, Minsung et al., "Performance of a Residential Heat Pump Operating in the Cooling Mode With Single Faults Imposed", Sep. 2006, U.S. Department of Commerce, NISTIR 7350 (175 pages).
- Li et al., "Development, Evaluation, and Demonstration of a Virtual Refrigerant Charge Sensor," Jan. 2009, HVAC&R Research, Oct. 27, 2008, 21 pages.
- Liao et al., A Correlation of Optimal Heat Rejection Pressures in Transcritical Carbon Dioxide Cycles, *Applied Thermal Engineering* 20 (2000), Jul. 25, 1999, 831-841.
- LIPA Launches Free, First-in-Nation Internet-Based Air Conditioner Control Program to Help LIPA and Its Customers Conserve Electricity & Save Money, Apr. 19, 2001, http://www.lipower.org/newscenter/pr/2001/aprill9_0l.html, 3 pages.
- Louis Goodman et al. "Vertical Motion of Neutrally Buoyant Floats." *Journal of Atmospheric and Oceanic Technology*. vol. 7. Feb. 1990.
- Low-Cost Multi-Service Home Gateway Creates New Business Opportunities, Coactive Networks, Copyright 1998-1999, 7 pages.
- Nickles, Donald, "Broadband Communications Over Power Transmission Lines," A Guest Lecture From the Dr. Shreekanth Mandaynam Engineering Frontiers Lecture Series, May 5, 2004, 21 pages.
- Non Final Office Action from related U.S. Appl. No. 13/269,188 dated Aug. 14, 2012; 9 pages.
- Non Final Office Action from related U.S. Appl. No. 13/269,188 dated Feb. 20, 2014; 9 pages.
- Non Final Office Action from related U.S. Appl. No. 13/269,188 dated Jul. 17, 2014; 10 pages.
- Non Final Office Action from related U.S. Appl. No. 13/369,067 dated Jan. 16, 2014; 16 pages.
- Non Final Office Action from related U.S. Appl. No. 13/767,479 dated Oct. 24, 2013; 8 pages.
- Non Final Office Action from related U.S. Appl. No. 13/767,479 dated Jul. 23, 2014; 9 pages.
- Non Final Office Action from related U.S. Appl. No. 13/835,621 dated Oct. 30, 2013; 8 pages.
- Non Final Office Action from related U.S. Appl. No. 13/835,621 dated Apr. 2, 2014; 11 pages.
- Non Final Office Action from related U.S. Appl. No. 13/835,742 dated Oct. 7, 2013; 9 pages.
- Non Final Office Action from related U.S. Appl. No. 13/835,810 dated Nov. 15, 2013; 9 pages.
- Non Final Office Action from related U.S. Appl. No. 13/836,043 dated Oct. 23, 2013; 8 pages.
- Non Final Office Action from related U.S. Appl. No. 13/836,043 dated Jul. 11, 2014; 5 pages.
- Non Final Office Action from related U.S. Appl. No. 13/836,244 dated Oct. 15, 2013; 11 pages.
- Non Final Office Action from related U.S. Appl. No. 13/836,244 dated Feb. 20, 2014; 10 pages.
- Non Final Office Action from related U.S. Appl. No. 13/836,453 dated Aug. 20, 2013; 8 pages.
- Non-Final Office Action for U.S. Appl. No. 11/098,575 dated Jan. 27, 2010.
- Non-Final Office Action for U.S. Appl. No. 11/776,879, dated Mar. 16, 2012.
- Non-Final Office Action for U.S. Appl. No. 12/054,011, dated Oct. 20, 2011.
- Non-Final Office Action for U.S. Appl. No. 12/054,011, dated Apr. 10, 2012.
- Non-Final Office Action for U.S. Appl. No. 12/685,375, dated Aug. 6, 2012.
- Non-Final Office Action for U.S. Appl. No. 13/030,549, dated Nov. 5, 2012.
- Non-Final Office Action in U.S. Appl. No. 11/850,846, dated May 24, 2013.
- Non-Final Office Action in U.S. Appl. No. 12/685,375, dated Jan. 19, 2012.
- Non-Final Office Action dated Mar. 3, 2011 for U.S. Appl. No. 12/054,011.
- Non-Final Office Action dated Aug. 13, 2010 for U.S. Appl. No. 12/054,011.
- Non-Final Office Action regarding U.S. Appl. No. 13/770,479, dated Mar. 16, 2015.
- Non-Final Office Action regarding U.S. Appl. No. 13/269,188, dated Oct. 4, 2013.
- Non-Final Office Action regarding U.S. Appl. No. 13/269,188, dated Oct. 6, 2014.
- Non-Final Office Action regarding U.S. Appl. No. 13/369,067, dated Aug. 12, 2014.
- Non-Final Office Action regarding U.S. Appl. No. 13/407,180, dated Dec. 2, 2014.
- Non-Final Office Action regarding U.S. Appl. No. 13/770,123, dated Jul. 3, 2013.
- Non-Final Office Action regarding U.S. Appl. No. 13/770,479, dated Jan. 16, 2014.
- Non-Final Office Action regarding U.S. Appl. No. 13/770,479, dated Sep. 7, 2016.
- Non-Final Office Action regarding U.S. Appl. No. 13/784,890, dated Jun. 11, 2013.
- Non-Final Office Action regarding U.S. Appl. No. 13/835,621, dated Aug. 8, 2014.
- Non-Final Office Action regarding U.S. Appl. No. 13/932,611, dated Nov. 25, 2013.
- Non-Final Office Action regarding U.S. Appl. No. 14/949,090 dated Jul. 5, 2018.
- Non-Final Office Action regarding U.S. Appl. No. 15/096,186, dated Sep. 20, 2018.
- Non-Final Office Action regarding U.S. Appl. No. 15/613,375 dated Aug. 30, 2018.
- Non-Final Office Action regarding U.S. Appl. No. 11/214,179, dated Jan. 24, 2011.
- Non-Final Office Action regarding U.S. Appl. No. 11/214,179, dated Nov. 5, 2008.
- Non-Final Office Action regarding U.S. Appl. No. 11/214,179, dated Jun. 8, 2010.
- Non-Final Office Action regarding U.S. Appl. No. 12/261,643, dated Jan. 27, 2011.
- Non-Final Office Action regarding U.S. Appl. No. 12/261,643, dated Mar. 12, 2013.
- Non-Final Office Action regarding U.S. Appl. No. 12/943,626, dated Dec. 20, 2012.
- Non-Final Office Action regarding U.S. Appl. No. 12/955,355, dated Sep. 11, 2012.
- Non-Final Office Action regarding U.S. Appl. No. 13/176,021, dated May 8, 2012.
- Non-Final Office Action regarding U.S. Appl. No. 13/435,543, dated Jun. 21, 2012.
- Non-Final Office Action regarding U.S. Appl. No. 13/770,123, dated Jun. 11, 2014.
- Non-Final Office Action regarding U.S. Appl. No. 13/932,611, dated Jan. 30, 2015.
- Notice of Allowance and Fee(s) Due regarding U.S. Appl. No. 12/789,562, dated Oct. 26, 2012.
- Notice of Allowance and Fees Due and Notice of Allowability regarding U.S. Appl. No. 11/098,582, dated Feb. 24, 2009.
- Notice of Allowance and Fees Due and Notice of Allowability regarding U.S. Appl. No. 11/098,582, dated Sep. 24, 2010.
- Notice of Allowance and Fees Due and Notice of Allowability regarding U.S. Appl. No. 11/256,641, dated May 19, 2009.
- Notice of Allowance and Fees Due regarding U.S. Appl. No. 12/261,643, dated Jun. 23, 2014.
- Notice of Allowance and Fees Due regarding U.S. Appl. No. 12/943,626, dated Jun. 19, 2014.
- Notice of Allowance and Fees Due regarding U.S. Appl. No. 13/737,566, dated Jun. 18, 2014.
- Notice of Allowance and Fees Due regarding U.S. Appl. No. 13/737,566, dated Sep. 24, 2014.

(56)

References Cited

OTHER PUBLICATIONS

Notice of Allowance and Fees Due, Interview Summary and Notice of Allowability regarding U.S. Appl. No. 11/214,179, dated Nov. 23, 2011.

Notice of Allowance and Interview Summary regarding U.S. Appl. No. 13/269,188, dated Aug. 26, 2015.

Notice of Allowance and Notice of Allowability regarding U.S. Appl. No. 10/286,419, dated Dec. 2, 2004.

Notice of Allowance dated Dec. 21, 2007 from Related U.S. Appl. No. 11/417,609.

Notice of Allowance dated Dec. 3, 2007 from Related U.S. Appl. No. 11/130,562.

Notice of Allowance dated Feb. 12, 2007 from Related U.S. Appl. No. 11/130,871.

Notice of Allowance dated Jul. 13, 2006 from Related U.S. Appl. No. 11/130,601.

Notice of Allowance dated Jul. 25, 2007 from Related U.S. Appl. No. 10/916,223.

Notice of Allowance dated Jun. 11, 2007 from Related U.S. Appl. No. 10/916,222.

Notice of Allowance dated May 29, 2007 from Related U.S. Appl. No. 11/130,569.

Notice of Allowance dated Nov. 3, 2008 from Related U.S. Appl. No. 11/417,701.

Notice of Allowance dated Oct. 26, 2007 from Related U.S. Appl. No. 10/916,223.

Notice of Allowance for U.S. Appl. No. 13/835,742 dated Dec. 24, 2014.

Notice of Allowance for U.S. Appl. No. 13/835,810 dated Jan. 2, 2015.

Notice of Allowance for related U.S. Appl. No. 13/835,810 dated Aug. 5, 2014.

Notice of Allowance for related U.S. Appl. No. 13/836,244, dated Oct. 30, 2014.

Notice of Allowance for U.S. Appl. No. 10/698,048, dated Sep. 1, 2005.

Notice of Allowance from related U.S. Appl. No. 13/835,810 dated Mar. 20, 2014; 9 pages.

Notice of Allowance from related U.S. Appl. No. 13/836,244 dated Jul. 2, 2014; 8 pages.

Notice of Allowance regarding U.S. Appl. No. 13/767,479, dated Mar. 31, 2015.

Notice of Allowance regarding U.S. Appl. No. 13/770,123, dated Oct. 1, 2015.

Notice of Allowance regarding U.S. Appl. No. 13/835,621, dated Mar. 10, 2015.

Notice of Allowance regarding U.S. Appl. No. 13/835,742, dated Jan. 31, 2014.

Notice of Allowance regarding U.S. Appl. No. 13/835,742, dated Jun. 2, 2014.

Notice of Allowance regarding U.S. Appl. No. 13/835,742, dated Apr. 17, 2015.

Notice of Allowance regarding U.S. Appl. No. 13/836,043, dated Feb. 4, 2015.

Notice of Allowance regarding U.S. Appl. No. 13/836,043, dated Oct. 9, 2014.

Notice of Allowance regarding U.S. Appl. No. 13/836,453, dated Apr. 21, 2014.

Notice of Allowance regarding U.S. Appl. No. 13/836,453, dated Aug. 4, 2014.

Notice of Allowance regarding U.S. Appl. No. 13/836,453, dated Dec. 24, 2014.

Notice of Allowance regarding U.S. Appl. No. 13/836,453, dated Jan. 14, 2014.

Notice of Allowance regarding U.S. Appl. No. 12/261,643, dated Jul. 29, 2015.

Notice of Allowance regarding U.S. Appl. No. 13/369,067, dated Sep. 2, 2015.

Notice of Allowance regarding U.S. Appl. No. 13/407,180, dated Sep. 4, 2015.

Notice of Allowance regarding U.S. Appl. No. 13/770,123, dated Aug. 13, 2015.

Notice of Allowance regarding U.S. Appl. No. 13/836,453, dated Apr. 15, 2015.

Notice of Allowance regarding U.S. Appl. No. 13/932,611, dated Jul. 6, 2015.

Notice of Allowance regarding U.S. Appl. No. 14/208,636 dated Jul. 30, 2018.

Notice of Allowance regarding U.S. Appl. No. 14/208,636 dated Sep. 25, 2018.

Notice of Allowance regarding U.S. Appl. No. 14/607,782 dated Jul. 3, 2018.

Notice of Allowance regarding U.S. Appl. No. 14/607,782 dated May 21, 2018.

Notice of Allowance regarding U.S. Appl. No. 15/583,942 dated Aug. 7, 2018.

Notice of Allowance regarding U.S. Appl. No. 15/645,970 dated Jun. 29, 2018.

Notice of Allowance regarding U.S. Appl. No. 15/645,970 dated Oct. 31, 2018.

Notice of Allowance regarding U.S. Appl. No. 10/061,964, dated Jul. 19, 2004.

Notice of Allowance regarding U.S. Appl. No. 10/940,877, dated Sep. 4, 2009.

Notice of Allowance regarding U.S. Appl. No. 11/776,879, dated Jul. 9, 2012.

Notice of Allowance regarding U.S. Appl. No. 12/261,677, dated Dec. 15, 2011.

Notice of Allowance regarding U.S. Appl. No. 13/303,286, dated Jul. 19, 2012.

Notice of Grounds for Refusal regarding Korean Patent Application No. 10-2009-7000850, dated Oct. 4, 2013. English translation provided by Y.S. Chang & Associates.

Notice of Panel Decision from Pre-Appeal Brief Review regarding U.S. Appl. No. 09/977,552, dated Aug. 4, 2009.

Notification of First Office Action from the State Intellectual Property Office of People's Republic of China regarding Chinese Patent Application No. 200880122964.6, dated Nov. 5, 2012. Translation provided by Unitalen Attorneys at Law.

Office Action and Interview Summary regarding U.S. Appl. No. 14/244,967, dated Oct. 7, 2015.

Office Action Communication regarding U.S. Appl. No. 09/977,552, dated Apr. 18, 2007.

Office Action dated Apr. 19, 2006 from Related U.S. Appl. No. 10/916,223.

Office Action dated Aug. 17, 2007 from Related U.S. Appl. No. 11/417,609.

Office Action dated Aug. 17, 2007 from Related U.S. Appl. No. 11/417,701.

Office Action dated Aug. 21, 2007 from Related U.S. Appl. No. 11/417,557.

Office Action dated Feb. 1, 2007 from Related U.S. Appl. No. 11/130,562.

Office Action dated Feb. 13, 2009 from Related U.S. Appl. No. 12/033,765.

Office Action dated Feb. 13, 2009 from Related U.S. Appl. No. 12/050,821.

Office Action dated Feb. 15, 2008 from Related U.S. Appl. No. 11/417,557.

Office Action dated Feb. 3, 2009 from Related U.S. Appl. No. 11/866,295.

Office Action dated Jan. 18, 2006 from Related U.S. Appl. No. 11/130,601.

Office Action dated Jan. 18, 2006 from Related U.S. Appl. No. 11/130,871.

Office Action dated Jan. 23, 2007 from Related U.S. Appl. No. 10/916,222.

Office Action dated Jan. 6, 2006 from Related U.S. Appl. No. 11/130,562.

Office Action dated Jan. 6, 2006 from Related U.S. Appl. No. 10/916,222.

Office Action dated Jul. 1, 2008 from Related U.S. Appl. No. 11/927,425.

(56)

References Cited

OTHER PUBLICATIONS

- Office Action dated Jul. 11, 2006 from Related U.S. Appl. No. 11/130,562.
- Office Action dated Jul. 11, 2006 from Related U.S. Appl. No. 10/916,222.
- Office Action dated Jul. 11, 2007 from Related U.S. Appl. No. 11/417,609.
- Office Action dated Jul. 11, 2007 from Related U.S. Appl. No. 11/417,701.
- Office Action dated Jul. 16, 2008 from Related U.S. Appl. No. 11/417,701.
- Office Action dated Jul. 24, 2008 from Related U.S. Appl. No. 11/417,557.
- Office Action dated Jul. 27, 2006 from Related U.S. Appl. No. 11/130,871.
- Office Action dated Jun. 17, 2009 from Related U.S. Appl. No. 12/033,765.
- Office Action dated Jun. 19, 2009 from Related U.S. Appl. No. 11/866,295.
- Office Action dated Jun. 22, 2009 from Related U.S. Appl. No. 12/050,821.
- Office Action dated Jun. 27, 2007 from Related U.S. Appl. No. 11/417,557.
- Office Action dated Mar. 30, 2006 from Related U.S. Appl. No. 11/130,569.
- Office Action dated May 4, 2005 from Related U.S. Appl. No. 10/916,223.
- Office Action dated May 6, 2009 from Related U.S. Appl. No. 11/830,729.
- Office Action dated Nov. 14, 2006 from Related U.S. Appl. No. 11/130,569.
- Office Action dated Nov. 16, 2006 from Related U.S. Appl. No. 10/916,223.
- Office Action dated Nov. 8, 2005 from Related U.S. Appl. No. 10/916,222.
- Office Action dated Nov. 9, 2005 from Related U.S. Appl. No. 11/130,562.
- Office Action dated Nov. 9, 2005 from Related U.S. Appl. No. 11/130,601.
- Office Action dated Nov. 9, 2005 from Related U.S. Appl. No. 11/130,871.
- Office Action dated Oct. 27, 2005 from Related U.S. Appl. No. 10/916,223.
- Office Action dated Sep. 18, 2007 from Related U.S. Appl. No. 11/130,562.
- Office Action for U.S. Appl. No. 13/835,621 dated Dec. 29, 2014.
- Office Action for Canadian Application No. 2,828,740 dated Jan. 12, 2015.
- Office Action for related U.S. Appl. No. 13/767,479, dated Oct. 21, 2014.
- Office Action for U.S. Appl. No. 11/394,380, dated Jan. 6, 2009.
- Office Action for U.S. Appl. No. 11/497,579, dated Oct. 27, 2009.
- Office Action for U.S. Appl. No. 11/497,644, dated Dec. 19, 2008.
- Office Action for U.S. Appl. No. 11/497,644, dated Jul. 10, 2009.
- Office Action from U.S. Appl. No. 13/369,067 dated Apr. 3, 2015.
- Office Action regarding U.S. Appl. No. 13/770,123, dated Apr. 2, 2015.
- Office Action regarding Australian Patent Application No. 2013323760, dated Sep. 25, 2015.
- Office Action regarding Australian Patent Application No. 2014229103, dated Apr. 28, 2016.
- Office Action regarding Australian Patent Application No. 2014248049, dated Oct. 10, 2017.
- Office Action regarding Australian Patent Application No. 2015207920, dated Dec. 4, 2015.
- Office Action regarding Australian Patent Application No. 2015255255, dated Sep. 8, 2016.
- Office Action regarding Canadian Patent Application No. 2,904,734, dated Sep. 13, 2016.
- Office Action regarding Canadian Patent Application No. 2,908,362, dated Sep. 21, 2016.
- Office Action regarding Canadian Patent Application No. 2,934,860, dated May 4, 2017.
- Office Action regarding Chinese Patent Application No. 201380005300.2, dated Jan. 4, 2016. Translation provided by Unitalen Attorneys at Law.
- Office Action regarding Chinese Patent Application No. 201380049458.X, dated Nov. 13, 2015. Translation provided by Unitalen Attorneys at Law.
- Office Action regarding Chinese Patent Application No. 201480016023.X, dated Jun. 22, 2016. Translation provided by Unitalen Attorneys at Law.
- Office Action regarding Chinese Patent Application No. 201480016177.9, dated Apr. 7, 2017. Translation provided by Unitalen Attorneys at Law.
- Office Action regarding Chinese Patent Application No. 201480025776.7, dated Jan. 10, 2018. Translation provided by Unitalen Attorneys at Law.
- Office Action regarding European Patent Application No. 07796879.0, dated Oct. 19, 2017.
- Office Action regarding European Patent Application No. 07811712.4, dated Jul. 25, 2017.
- Office Action regarding European Patent Application No. 08848538.8, dated Feb. 3, 2016.
- Office Action regarding Indian Patent Application No. 102/KOLNP/2009, dated Mar. 10, 2017.
- Office Action regarding Indian Patent Application No. 456/MUMNP/2010, dated Oct. 3, 2017.
- Office Action regarding Indian Patent Application No. 733/KOLNP/2009, dated Aug. 12, 2015.
- Office Action regarding U.S. Appl. No. 10/286,419, dated Jun. 10, 2004.
- Office Action regarding U.S. Appl. No. 11/098,575, dated Jan. 29, 2009.
- Office Action regarding U.S. Appl. No. 11/098,575, dated Mar. 26, 2008.
- Office Action regarding U.S. Appl. No. 11/098,575, dated Jul. 13, 2009.
- Office Action regarding U.S. Appl. No. 11/098,575, dated Sep. 9, 2008.
- Office Action regarding U.S. Appl. No. 11/120,166, dated Oct. 2, 2006.
- Office Action regarding U.S. Appl. No. 11/120,166, dated Oct. 2, 2007.
- Office Action regarding U.S. Appl. No. 11/120,166, dated Dec. 15, 2008.
- Office Action regarding U.S. Appl. No. 11/120,166, dated Feb. 17, 2010.
- Office Action regarding U.S. Appl. No. 11/120,166, dated Apr. 12, 2007.
- Office Action regarding U.S. Appl. No. 11/120,166, dated Jun. 5, 2008.
- Office Action regarding U.S. Appl. No. 11/120,166, dated Jul. 20, 2009.
- Office Action regarding U.S. Appl. No. 11/394,380, dated Sep. 25, 2009.
- Office Action regarding U.S. Appl. No. 11/497,644, dated Jan. 29, 2010.
- Office Action regarding U.S. Appl. No. 11/497,644, dated Jun. 14, 2010.
- Office Action regarding U.S. Appl. No. 12/943,626, dated May 4, 2016.
- Office Action regarding U.S. Appl. No. 12/943,626, dated Nov. 4, 2016.
- Office Action regarding U.S. Appl. No. 13/770,479, dated Mar. 17, 2017.
- Office Action regarding U.S. Appl. No. 14/080,473, dated Jun. 6, 2016.
- Office Action regarding U.S. Appl. No. 14/080,473, dated Mar. 14, 2017.
- Office Action regarding U.S. Appl. No. 14/080,473, dated Nov. 16, 2016.

(56)

References Cited

OTHER PUBLICATIONS

- Office Action regarding U.S. Appl. No. 14/193,568, dated Jun. 1, 2016.
- Office Action regarding U.S. Appl. No. 14/193,568, dated Nov. 3, 2015.
- Office Action regarding U.S. Appl. No. 14/208,636 dated Jan. 3, 2018.
- Office Action regarding U.S. Appl. No. 14/208,636, dated Aug. 4, 2016.
- Office Action regarding U.S. Appl. No. 14/208,636, dated Jan. 26, 2017.
- Office Action regarding U.S. Appl. No. 14/209,415, dated Mar. 10, 2016.
- Office Action regarding U.S. Appl. No. 14/209,415, dated Sep. 10, 2015.
- Office Action regarding U.S. Appl. No. 14/212,632, dated Apr. 7, 2016.
- Office Action regarding U.S. Appl. No. 14/212,632, dated Nov. 19, 2015.
- Office Action regarding U.S. Appl. No. 14/244,967, dated Aug. 29, 2016.
- Office Action regarding U.S. Appl. No. 14/244,967, dated Jan. 20, 2017.
- Office Action regarding U.S. Appl. No. 14/255,519, dated Nov. 9, 2015.
- Office Action regarding U.S. Appl. No. 14/255,519, dated Oct. 5, 2016.
- Office Action regarding U.S. Appl. No. 14/300,782, dated Sep. 30, 2016.
- Office Action regarding U.S. Appl. No. 14/607,782, dated Sep. 21, 2017.
- Office Action regarding U.S. Appl. No. 14/617,451, dated Jun. 2, 2016.
- Office Action regarding U.S. Appl. No. 14/727,756, dated Aug. 22, 2016.
- Office Action regarding U.S. Appl. No. 15/096,196, dated Sep. 13, 2016.
- Office Action regarding U.S. Appl. No. 15/645,970 dated Feb. 16, 2018.
- Office Action regarding U.S. Appl. No. 09/977,552, dated Jan. 11, 2008.
- Office Action regarding U.S. Appl. No. 09/977,552, dated Jan. 14, 2003.
- Office Action regarding U.S. Appl. No. 09/977,552, dated Oct. 18, 2004.
- Office Action regarding U.S. Appl. No. 09/977,552, dated Dec. 3, 2003.
- Office Action regarding U.S. Appl. No. 09/977,552, dated Jul. 12, 2006.
- Office Action regarding U.S. Appl. No. 10/061,964, dated Oct. 3, 2003.
- Office Action regarding U.S. Appl. No. 10/675,137, dated Sep. 7, 2004.
- Office Action regarding U.S. Appl. No. 10/698,048, dated Mar. 21, 2005.
- Office Action regarding U.S. Appl. No. 10/940,877, dated Oct. 27, 2006.
- Office Action regarding U.S. Appl. No. 10/940,877, dated Nov. 14, 2005.
- Office Action regarding U.S. Appl. No. 10/940,877, dated Dec. 8, 2008.
- Office Action regarding U.S. Appl. No. 10/940,877, dated May 21, 2007.
- Office Action regarding U.S. Appl. No. 10/940,877, dated Jun. 5, 2008.
- Office Action regarding U.S. Appl. No. 11/098,582, dated Mar. 3, 2010.
- Office Action regarding U.S. Appl. No. 11/098,582, dated Jul. 7, 2008.
- Office Action regarding U.S. Appl. No. 11/098,582, dated Aug. 4, 2009.
- Office Action regarding U.S. Appl. No. 11/098,582, dated Sep. 21, 2007.
- Office Action regarding U.S. Appl. No. 11/256,641, dated Apr. 29, 2008.
- Office Action regarding U.S. Appl. No. 11/337,918, dated Mar. 25, 2008.
- Office Action regarding U.S. Appl. No. 11/337,918, dated Aug. 17, 2009.
- Office Action regarding U.S. Appl. No. 11/337,918, dated Oct. 28, 2008.
- Office Action regarding U.S. Appl. No. 11/776,879, dated Sep. 17, 2010.
- Office Action regarding U.S. Appl. No. 11/850,846, dated Aug. 13, 2010.
- Office Action regarding U.S. Appl. No. 12/261,643, dated Nov. 2, 2011.
- Office Action regarding U.S. Appl. No. 12/261,643, dated Feb. 15, 2012.
- Office Action regarding U.S. Appl. No. 12/261,677, dated Aug. 4, 2011.
- Office Action regarding U.S. Appl. No. 13/303,286, dated Mar. 26, 2012.
- Office Action regarding U.S. Appl. No. 13/737,566, dated Dec. 20, 2013.
- Official Action regarding Australian Patent Application No. 2008325240, dated Jan. 19, 2011.
- Palani, M. et al, Monitoring the Performance of a Residential Central Air Conditioner under Degraded Conditions on a Test Bench, ESL-TR-92/05-05, May 1992.
- Palani, M. et al, The Effect of Reduced Evaporator Air Flow on the Performance of a Residential Central Air Conditioner, ESL-HH-92-05-04, Energy Systems Laboratory, Mechanical Engineering Department, Texas A&M University, Eighth Symposium on Improving Building System in Hot and Humid Climates, May 13-14, 1992.
- Patent Examination Report for Australian Application No. 2012223466 dated Jan. 6, 2015.
- Patent Examination Report No. 3 regarding Australian Patent Application No. 2008325240, dated Jul. 19, 2012.
- Pin, C. et al., "Predictive Models as Means to Quantify the Interactions of Spoilage Organisms," International Journal of Food Microbiology, vol. 41, No. 1, 1998, pp. 59-72, XP-002285119.
- Record of Oral Hearing regarding U.S. Appl. No. 09/977,552, dated Nov. 29, 2012.
- Reh, F. John, "Cost Benefit Analysis", <http://management.about.com/cs/money/a/CostBenefit.htm>, Dec. 8, 2003.
- Response to Rule 312 Communication regarding U.S. Appl. No. 09/977,552, dated Oct. 31, 2003.
- Restriction Requirement regarding U.S. Appl. No. 11/776,879, dated Jun. 4, 2010.
- Restriction Requirement regarding U.S. Appl. No. 13/269,188, dated Apr. 9, 2013.
- Restriction Requirement regarding U.S. Appl. No. 14/244,967, dated Jul. 14, 2015.
- Restriction Requirement regarding U.S. Appl. No. 14/607,782, dated Jun. 29, 2017.
- Restriction Requirement regarding U.S. Appl. No. 10/940,877, dated Jul. 25, 2005.
- Restriction Requirement regarding U.S. Appl. No. 11/214,179, dated Feb. 2, 2010.
- Richard E. Lofftus, Jr. "System Charge and Performance Evaluation." HVAC/R Training, Vatterott College. Jan. 2007.
- Search Report regarding Chinese Patent Application No. 201610244700.4, dated Mar. 25, 2018.
- Search Report regarding European Patent Application No. 08251185.8-1605 / 2040016, dated Dec. 4, 2015.
- Search Report regarding European Patent Application No. 10830696.0, dated Jul. 18, 2017.
- Search Report regarding European Patent Application No. 12752872.7, dated May 4, 2017.
- Search Report regarding European Patent Application No. 13736303.2-1806, dated Sep. 17, 2015.

(56)

References Cited

OTHER PUBLICATIONS

- Search Report regarding European Patent Application No. 13841699.5, dated Jun. 30, 2016.
- Search Report regarding European Patent Application No. 14763232.7, dated Oct. 27, 2016.
- Search Report regarding European Patent Application No. 14764311.8, dated Oct. 27, 2016.
- Search Report regarding European Patent Application No. 14780284.7, dated Nov. 2, 2016.
- Search Report regarding European Patent Application No. 16187893.9, dated Jan. 19, 2017.
- Second Examination Communication regarding European Application No. EP02729051.9, dated Jul. 3, 2006.
- Second Office Action from the State Intellectual Property Office of People's Republic of China regarding Chinese Patent Application No. 201110349785.X, dated Jul. 25, 2014. Translation provided by Unitalen Attorneys at Law.
- Second Office Action issued by the Chinese Patent Office for Application No. 200480015875.3, dated Feb. 27, 2009.
- Second Office Action issued by the Chinese Patent Office on Mar. 6, 2009 regarding Application No. 200580013451.8, 7 Pages. Translation provided by CCPIT Patent and Trademark Law Office.
- Second Office Action received from the Chinese Patent Office dated Jun. 26, 2009 regarding Application No. 200480011463.2, translated by CCPIT Patent and Trademark Law Office.
- Second Office Action regarding Chinese Patent Application No. 200780030810.X, dated Aug. 4, 2010. English translation provided by Unitalen Attorneys at Law.
- Second Office Action regarding Chinese Patent Application No. 200890100287.3, dated Jan. 27, 2011. English translation provided by Unitalen Attorneys at Law.
- Second Office Action regarding Chinese Patent Application No. 200910211779.0, dated Feb. 4, 2013. English translation provided by Unitalen Attorneys at Law.
- Second Official Report regarding Australian Patent Application No. 2007214381, dated Oct. 30, 2009.
- Supplementary European Search Report for EP 02731544, dated Jun. 18, 2004, 2 Pages.
- Supplementary European Search Report regarding Application No. PCT/US2006/005917, dated Nov. 23, 2009.
- Supplementary European Search Report regarding European Application No. EP06790063, dated Jun. 15, 2010.
- Tamarkin, Tom D., "Automatic Meter Reading," Public Power magazine, vol. 50, No. 5, Sep.-Oct. 1992, <http://www.energycite.com/news/amr.html>, 6 pages.
- Texas Instruments, Inc. Mechanical Data for "PT (S-PQFP-G48) Plastic Quad Flatpack," Revised Dec. 1996, 2 pages.
- Texas Instruments, Inc., Product catalog for "TRF690 1 Single-Chip RF Transceiver," Copyright 2001-2003, Revised Oct. 2003, 27 pages.
- The Honeywell HVAC Service Assistant, A Tool for Reducing Electrical Power Demand and Energy Consumption, Field Diagnostics, 2003.
- The LS2000 Energy Management System, User Guide, <http://www.surfnetworks.com/htmlmanuals/IonWorksEnergyManagement-LS2000-Load-Shed-System-by-Surf-Networks,Inc.html>, Sep. 2004, 20 pages.
- Third Chinese Office Action regarding Application No. 201110349785.X, dated Jan. 30, 2015. Translation provided by Unitalen Attorneys at Law.
- Third Office Action regarding Chinese Application No. 2005100059078 from the State Intellectual Property Office of People's Republic of China, dated Aug. 24, 2011. Translation provided by Unitalen Attorneys at Law.
- Torcellini, P., et al., "Evaluation of the Energy Performance and Design Process of the Thermal Test Facility at the National Renewable Energy Laboratory", dated Feb. 2005.
- Trane EarthWise™ CenTra Vac™ Water-Cooled Liquid Chillers 165-3950 Tons 50 and 60 Hz; CTV PRC007-EN; Oct. 2002; 56 pages.
- Translation of claims and Abstract of KR Patent Laying-Open No. 2000-0000261.
- U.S. Office Action regarding U.S. Appl. No. 13/269,188, dated May 8, 2015.
- U.S. Office Action regarding U.S. Appl. No. 14/212,632, dated May 15, 2015.
- Udelhoven, Darrell, "Air Conditioner EER, SEER Ratings, BTUH Capacity Ratings, & Evaporator Heat Load," <http://www.udarrell.com/air-conditioner-capacity-seer.html>, Apr. 3, 2003, 15 pages.
- Udelhoven, Darrell, "Air Conditioning System Sizing for Optimal Efficiency," <http://www.udarrell.com/airconditioning-sizing.html>, Oct. 6, 2003, 7 pages.
- Udelhoven, Darrell, "Optimizing Air Conditioning Efficiency TuneUp Optimizing the Condenser Output, Seer, Air, HVAC Industry," <http://www.udarrell.com/air-conditioning-efficiency.html>, Jul. 19, 2002, 13 pages.
- Ultrasite 32 User's Guide, Computer Process Controls, Sep. 28, 1999.
- Ultrasite User's Guide BCU Supplement, Computer Process Controls, Sep. 4, 1997.
- Ultrasite User's Guide BEC Supplement, Computer Process Controls, Oct. 6, 1997.
- Ultrasite User's Guide RMCC Supplement, Computer Process Controls, Jun. 9, 1997.
- UltraSite User's Guide, Computer Process Controls, Apr. 1, 1996.
- Vandenbrink et al., "Design of a Refrigeration Cycle Evaporator Unit," Apr. 18, 2003.
- Watt, James; Development of Empirical Temperature and Humidity-Based Degraded-Condition Indicators for Low-Tonnage Air Conditioners; ESL-TH-97/12-03; Dec. 1997.
- Written Opinion from related PCT Application No. PCT/US2014/028074, dated Jun. 19, 2014.
- Written Opinion of International Searching Authority for International Application No. PCT/US2008/009618, dated Dec. 8, 2008.
- Written Opinion of the International Searching Authority for International Application No. PCT/US2008/012364, dated Mar. 13, 2009.
- Written Opinion of the International Searching Authority regarding Application No. PCT/US2007/016135, dated Oct. 22, 2007.
- Written Opinion of the International Searching Authority regarding Application No. PCT/US2010/036601, dated Dec. 29, 2010.
- Written Opinion of the International Searching Authority regarding Application No. PCT/US2012/026973, dated Sep. 3, 2012.
- Written Opinion of the International Searching Authority regarding Application No. PCT/US2013/021161, dated May 8, 2013.
- Written Opinion of the International Searching Authority regarding Application No. PCT/US2013/061389, dated Jan. 22, 2014.
- Written Opinion of the International Searching Authority regarding International Application No. PCT/US2007/019563, dated Jan. 15, 2008.
- Written Opinion of the International Searching Authority, International App. No. PCT/US06/05917, dated Sep. 26, 2007.
- Written Opinion regarding PCT/US02/13459, dated Apr. 23, 2003.
- U.S. Appl. No. 14/208,636, filed Mar. 13, 2014, Hung M. Pham.
- U.S. Appl. No. 14/949,090, filed Nov. 23, 2015, Nagaraj Jayanth et al.
- U.S. Appl. No. 15/096,186, filed Apr. 11, 2016, Lawrence Kates.
- U.S. Appl. No. 15/613,375, filed Jun. 5, 2017, Hung M. Pham.
- U.S. Appl. No. 15/633,657, filed Jun. 26, 2017, Lawrence Kates.
- U.S. Appl. No. 15/798,081, filed Oct. 30, 2017, Hung M. Pham.
- U.S. Appl. No. 16/357,235, filed Mar. 18, 2019, Jeffrey N. Arensmeier.
- Notice of Allowance regarding U.S. Appl. No. 14/949,090, dated Nov. 26, 2018.
- First Examination Report regarding Indian Patent Application No. 479/MUMNP/2015, dated Dec. 21, 2018.
- Office Action regarding U.S. Appl. No. 14/949,090, dated Feb. 14, 2019.
- Office Action regarding U.S. Appl. No. 15/633,657, dated Feb. 20, 2019.
- Notice of Allowance regarding U.S. Appl. No. 15/096,186, dated Feb. 26, 2019.
- Notice of Allowance regarding U.S. Appl. No. 15/613,375, dated Feb. 27, 2019.

(56)

References Cited

OTHER PUBLICATIONS

First Examination Report regarding Indian Patent Application No.
2574/MUMNP/2015, dated Mar. 20, 2019.

* cited by examiner

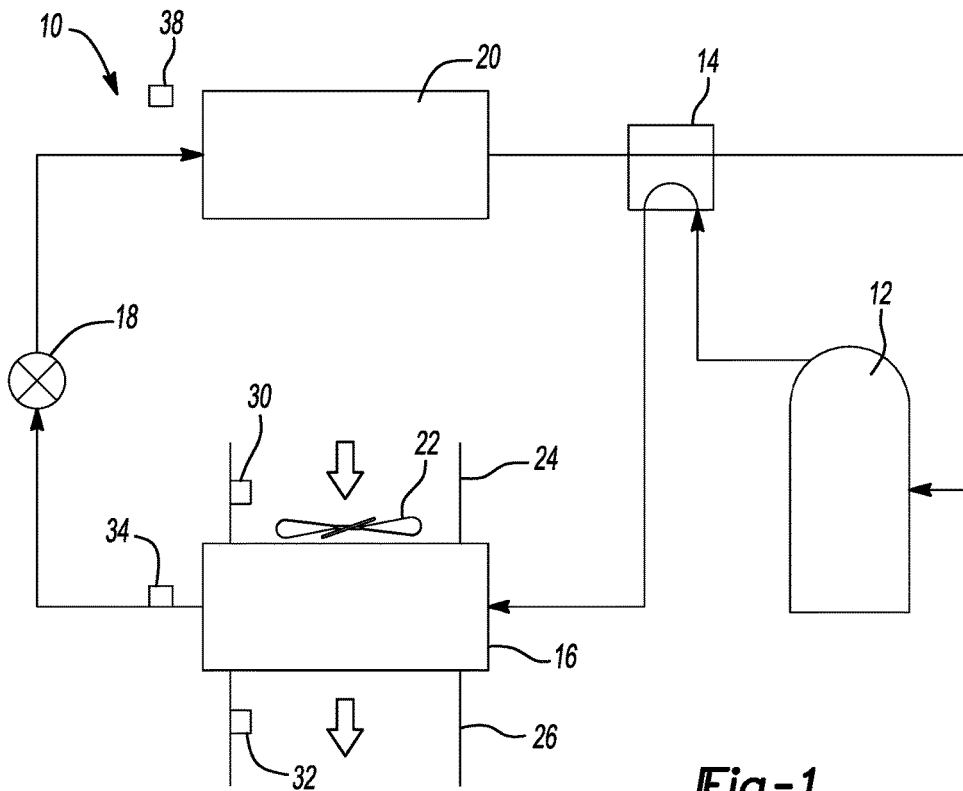

Fig-1

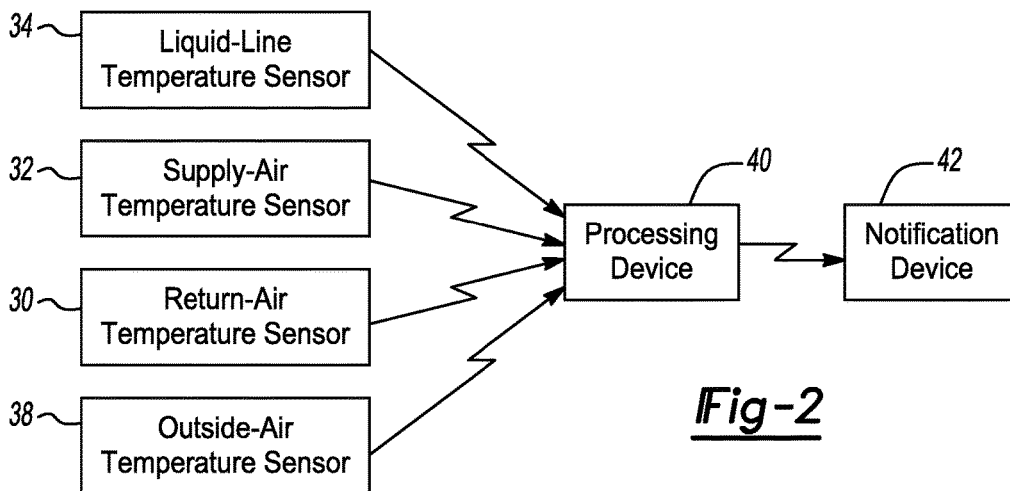
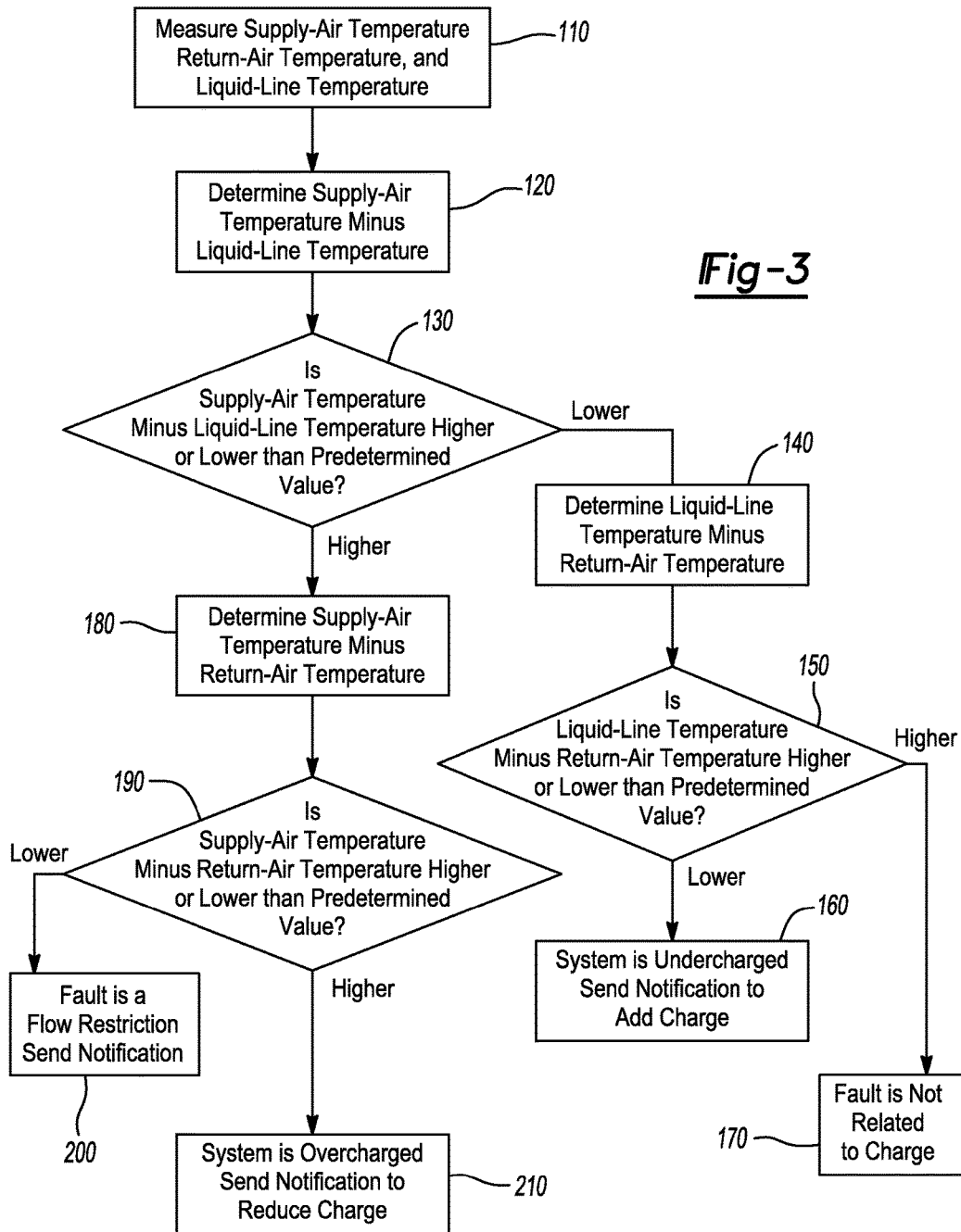

Fig-2



METHOD OF MONITORING CHARGE CONDITION OF HEAT PUMP SYSTEM

CROSS-REFERENCE TO RELATED APPLICATIONS

This application is a divisional of U.S. patent application Ser. No. 14/607,782 filed on Jan. 28, 2015, which is a continuation of U.S. patent application Ser. No. 14/244,967 (now U.S. Pat. No. 9,765,979) filed on Apr. 4, 2014, which claims the benefit of U.S. Provisional Application No. 61/808,688 filed on Apr. 5, 2013. The entire disclosures of the above applications are incorporated herein by reference.

FIELD

The present disclosure relates to a heat-pump system having refrigerant charge diagnostics.

BACKGROUND

This section provides background information related to the present disclosure and is not necessarily prior art.

A climate-control system such as, for example, a heat-pump system, a refrigeration system, or an air conditioning system, may include a fluid circuit having an outdoor heat exchanger, an indoor heat exchanger, an expansion device disposed between the indoor and outdoor heat exchangers, and a compressor circulating a working fluid (e.g., refrigerant or carbon dioxide) between the indoor and outdoor heat exchangers. Maintaining proper amounts of working fluid in the system (i.e., refrigerant charge levels) is desirable for effective and efficient operation of the climate-control system.

SUMMARY

This section provides a general summary of the disclosure, and is not a comprehensive disclosure of its full scope or all of its features.

In one form, the present disclosure provides a method that may include determining a working-fluid-charge condition of a heat-pump system based on at least one of a supply-air temperature and a return-air temperature. In some embodiments, the working-fluid charge condition may be determined by a cloud-based processing device.

In another form, a monitor may be provided for a heat-pump circuit. The heat-pump circuit may include an indoor heat exchanger, an outdoor heat exchanger, a compressor circulating a working fluid between the indoor and outdoor heat exchangers, and an expansion device between the indoor and outdoor heat exchangers. The monitor may include a return-air temperature sensor, a supply-air temperature sensor, and a processor. The return-air temperature sensor may be adapted to measure a first air temperature of air upstream of the indoor heat exchanger. The supply-air temperature sensor may be adapted to measure a second air temperature of air downstream of the indoor heat exchanger. The processor may be in communication with the return-air temperature sensor and the supply-air temperature sensor. The processor may be programmed to determine a working-fluid-charge condition of the heat-pump system based on the first and second air temperatures.

In some embodiments, the processor is programmed to determine the working-fluid-charge condition based on a

difference between the second air temperature and the first air temperature and a comparison of the difference with a predetermined value.

In some embodiments, the monitor includes a working-fluid temperature sensor disposed between the expansion device and the indoor heat exchanger and adapted to measure a working-fluid temperature of working fluid flowing between the indoor heat exchanger and the expansion device when the heat-pump system is operating in a heating mode. The processor may be in communication with the working-fluid temperature sensor and may be programmed to determine the working-fluid-charge condition of the heat-pump system based on the working-fluid temperature.

In some embodiments, the processor is programmed to determine the working-fluid-charge condition based a first difference between the second air temperature and the working-fluid temperature.

In some embodiments, the processor is programmed to determine the working-fluid-charge condition based on a second difference between the second air temperature and the first air temperature.

In some embodiments, the processor is programmed to determine the working-fluid charge condition based only on a first comparison of the first difference with a first predetermined value and a second comparison of the second difference with a second predetermined value.

In some embodiments, the processor is programmed to determine the working-fluid-charge condition based a third difference between the working-fluid temperature and the second air temperature.

In some embodiments, the processor is programmed to determine the working-fluid charge condition based on a first comparison of the first difference with a first predetermined value, a second comparison of the second difference with a second predetermined value, and a third comparison of the third difference with a third predetermined value.

In some embodiments, the processor is in communication with a notification device configured to generate a first alert indicating that a fault condition of the heat-pump system is related to the working-fluid-charge condition and a second alert indicating that the fault condition of the heat-pump system is unrelated to an amount of working fluid in the heat-pump system.

In some embodiments, the processor is a cloud-based processor. The notification device may include a mobile, wireless computing device, for example.

In some embodiments, the processor is in communication with a notification device configured to generate an alert indicating the working-fluid-charge condition.

In some embodiments, the processor is a cloud-based processor disposed remotely from the compressor, the return-air temperature sensor and the supply-air temperature sensor.

In another form, the present disclosure provides a method of monitoring a heat-pump system. The heat-pump system may include indoor and outdoor heat exchangers, a compressor adapted to circulate a working fluid between the indoor and outdoor heat exchangers, and an expansion device disposed between the indoor and outdoor heat exchangers. The method may include receiving a first air temperature value of air upstream of the indoor heat exchanger from a return-air temperature sensor; receiving a second air temperature of air downstream of the indoor heat exchanger from a supply-air temperature sensor; and determining a working-fluid-charge condition of the heat-pump

system using a processor programmed to determine the working-fluid-charge condition based on the first and second air temperatures.

In some embodiments, the working-fluid-charge condition is determined based on the first and second air temperatures and a working-fluid temperature measured by a working-fluid temperature sensor disposed downstream the indoor heat exchanger when the heat-pump system is in a heating mode.

In some embodiments, the first and second air temperature values are acquired while the heat-pump system is operating in a heating mode.

In some embodiments, the working-fluid temperature sensor is disposed between the indoor heat exchanger and the expansion device.

In some embodiments, the processor is programmed to determine the working-fluid-charge condition based on a difference between the second air temperature and the first air temperature and a comparison of the difference with a predetermined value.

In some embodiments, the method may include receiving a working-fluid temperature of working-fluid flowing between the indoor and outdoor heat exchangers. The processor may be programmed to determine the working-fluid-charge condition of the heat-pump system based on the working-fluid temperature.

In some embodiments, the method includes receiving a working-fluid temperature of working-fluid flowing between the indoor heat exchanger and the expansion device when the heat-pump system is operating in a heating mode. The processor may be programmed to determine the working-fluid-charge condition of the heat-pump system based on the working-fluid temperature.

In some embodiments, the processor is programmed to determine the working-fluid-charge condition based a first difference between the second air temperature and the working-fluid temperature.

In some embodiments, the processor may be programmed to determine the working-fluid-charge condition based on a second difference between the second air temperature and the first air temperature.

In some embodiments, the processor is programmed to determine the working-fluid charge condition based only on a first comparison of the first difference with a first predetermined value and a second comparison of the second difference with a second predetermined value.

In some embodiments, the processor is programmed to determine the working-fluid-charge condition based a third difference between the working-fluid temperature and the second air temperature.

In some embodiments, the processor is programmed to determine the working-fluid charge condition based on a first comparison of the first difference with a first predetermined value, a second comparison of the second difference with a second predetermined value, and a third comparison of the third difference with a third predetermined value.

In some embodiments, the method includes generating a first alert with a notification device indicating that a fault condition of the heat-pump system is related to the working-fluid-charge condition; and generating a second alert with the notification device indicating that the fault condition of the heat-pump system is unrelated to an amount of working fluid in the heat-pump system.

In another form, the present disclosure provides a working-fluid circuit having a processor in communication with a return-air temperature sensor and a supply-air temperature sensor, a compressor circulating a working fluid between the

indoor and outdoor heat exchangers, and an expansion device between the indoor and outdoor heat exchangers. The processor may be programmed to determine a working-fluid-charge condition of the working-fluid circuit based on a first air temperature of air upstream of the indoor heat exchanger from the return-air temperature sensor and a second air temperature of air downstream of the indoor heat exchanger from the supply-air temperature sensor.

Further areas of applicability will become apparent from the description provided herein. The description and specific examples in this summary are intended for purposes of illustration only and are not intended to limit the scope of the present disclosure.

DRAWINGS

The drawings described herein are for illustrative purposes only of selected embodiments and not all possible implementations, and are not intended to limit the scope of the present disclosure.

FIG. 1 is a schematic representation of a heat-pump system according to the principles of the present disclosure;

FIG. 2 is a schematic representation of a plurality of sensors associated with the heat-pump system communicating with a remote processing device; and

FIG. 3 is a flow chart illustrating a method of determining a charge level according to the principles of the present disclosure.

Corresponding reference numerals indicate corresponding parts throughout the several views of the drawings.

DETAILED DESCRIPTION

Example embodiments will now be described more fully with reference to the accompanying drawings.

Example embodiments are provided so that this disclosure will be thorough, and will fully convey the scope to those who are skilled in the art. Numerous specific details are set forth such as examples of specific components, devices, and methods, to provide a thorough understanding of embodiments of the present disclosure. It will be apparent to those skilled in the art that specific details need not be employed, that example embodiments may be embodied in many different forms and that neither should be construed to limit the scope of the disclosure. In some example embodiments, well-known processes, well-known device structures, and well-known technologies are not described in detail.

The terminology used herein is for the purpose of describing particular example embodiments only and is not intended to be limiting. As used herein, the singular forms “a,” “an,” and “the” may be intended to include the plural forms as well, unless the context clearly indicates otherwise. The terms “comprises,” “comprising,” “including,” and “having,” are inclusive and therefore specify the presence of stated features, integers, steps, operations, elements, and/or components, but do not preclude the presence or addition of one or more other features, integers, steps, operations, elements, components, and/or groups thereof. The method steps, processes, and operations described herein are not to be construed as necessarily requiring their performance in the particular order discussed or illustrated, unless specifically identified as an order of performance. It is also to be understood that additional or alternative steps may be employed.

When an element or layer is referred to as being “on,” “engaged to,” “connected to,” or “coupled to” another element or layer, it may be directly on, engaged, connected

or coupled to the other element or layer, or intervening elements or layers may be present. In contrast, when an element is referred to as being “directly on,” “directly engaged to,” “directly connected to,” or “directly coupled to” another element or layer, there may be no intervening elements or layers present. Other words used to describe the relationship between elements should be interpreted in a like fashion (e.g., “between” versus “directly between,” “adjacent” versus “directly adjacent,” etc.). As used herein, the term “and/or” includes any and all combinations of one or more of the associated listed items.

Although the terms first, second, third, etc. may be used herein to describe various elements, components, regions, layers and/or sections, these elements, components, regions, layers and/or sections should not be limited by these terms. These terms may be only used to distinguish one element, component, region, layer or section from another region, layer or section. Terms such as “first,” “second,” and other numerical terms when used herein do not imply a sequence or order unless clearly indicated by the context. Thus, a first element, component, region, layer or section discussed below could be termed a second element, component, region, layer or section without departing from the teachings of the example embodiments.

Spatially relative terms, such as “inner,” “outer,” “beneath,” “below,” “lower,” “above,” “upper,” and the like, may be used herein for ease of description to describe one element or feature’s relationship to another element(s) or feature(s) as illustrated in the figures. Spatially relative terms may be intended to encompass different orientations of the device in use or operation in addition to the orientation depicted in the figures. For example, if the device in the figures is turned over, elements described as “below” or “beneath” other elements or features would then be oriented “above” the other elements or features. Thus, the example term “below” can encompass both an orientation of above and below. The device may be otherwise oriented (rotated 90 degrees or at other orientations) and the spatially relative descriptors used herein interpreted accordingly.

With reference to FIG. 1, a heat-pump system 10 is provided that may include a compressor 12, a reversing valve 14, an indoor heat exchanger 16, an expansion device 18, and an outdoor heat exchanger 20. The compressor 12 can be a scroll compressor, a reciprocating compressor, or a rotary vane compressor, for example, or any other type of compressor. The reversing valve 14 may be a four-way valve operable to control a direction of working fluid flow through the heat-pump system 10. A controller (not shown) may switch the reversing valve 14 between a first position (not shown) corresponding to a cooling mode and a second position corresponding to a heating mode (shown in FIG. 1).

In the cooling mode, the outdoor heat exchanger 20 may operate as a condenser or as a gas cooler and may cool discharge-pressure working fluid received from the compressor 12 by transferring heat from the working fluid to ambient air, for example. In the heating mode, the outdoor heat exchanger 20 may operate as an evaporator.

In the cooling mode, the indoor heat exchanger 16 may operate as an evaporator and may transfer heat from a space to be cooled (e.g., a room within a house or building) to the working fluid in the indoor heat exchanger 16. In the heating mode, the indoor heat exchanger 16 may operate as a condenser or as a gas cooler and may transfer heat from working fluid discharged from the compressor 12 to a space to be heated. During operation of the heat-pump system 10, a fan 22 may draw air from the space to be heated or cooled through a return-air duct 24 and force the air across the

indoor heat exchanger 16 to transfer heat between the working fluid in the indoor heat exchanger 16 and the air. From the indoor heat exchanger 16, the heated or cooled air may be forced through a supply-air duct 26 to the space to be heated or cooled.

The heat-pump system 10 may also include a return-air temperature sensor 30, a supply-air temperature sensor 32, a liquid-line temperature sensor 34, and an outside-air temperature sensor 38. The return-air temperature sensor 30 may be disposed in the return-air duct 24 and may measure a temperature of the air flowing therethrough. The supply-air temperature sensor 32 may be disposed in the supply-air duct 26 and may measure a temperature of the air flowing therethrough. The liquid-line temperature sensor 34 may be disposed between the indoor heat exchanger 16 and the expansion device 18 and may measure a temperature of the working fluid flowing therebetween. The outside-air temperature sensor 38 may be disposed in any suitable location to measure a temperature of ambient air outside of the house or building.

As shown in FIG. 2, the sensors 30, 32, 34, 38 may be in communication with a remotely located or on-site processing device 40. In some embodiments, any or all of the sensors 30, 32, 34, 38 may be installed in the locations described above. In some embodiments, any or all of the sensors 30, 32, 34, 38 may be handheld sensors that a technician may temporarily place in the locations described above, obtain temperature measurements in those locations, and transmit the data to the processing device 40. Any or all of the sensors 30, 32, 34, 38 may be incorporated into a newly installed heat-pump system, or any or all of the sensors 30, 32, 34, 38 may be retrofitted to a pre-existing heat-pump system that has already been installed within a house or building. In some configurations, the outside-air temperature sensor 38 could be a thermometer or other sensor of a weather monitoring and/or weather reporting system or entity. In such configurations, the processor 40 may obtain the outside-air temperature measured by the sensor 38 from the weather monitoring and/or weather reporting system or entity via an internet, Bluetooth® or cellular connection, for example.

The processing device 40 may include a cloud-computing module having hardware (e.g., a processor and/or memory) and software capable of carrying the functionality described below. The processing device 40 may be in communication with a server that may receive data from the sensors 30, 32, 34, 38 via an internet connection or cellular network, for example. The processing device 40 may receive data from the sensors 30, 32, 34, 38 on demand, intermittently or in real time. In some embodiments, the processing device 40 may be located on a contractor or technician’s portable computing device (e.g., a laptop, tablet, smartphone or other device), or may be located within the house or building in which the heat-pump system 10 is installed (e.g., in a thermostat (not shown) or a control module (not shown) for the heat-pump system 10).

The processing device 40 may also be in communication with one or more notification devices 42 that may be disposed remotely from the processing device 40 and/or the sensors 30, 32, 34, 38. The notification devices 42 may include any of a desktop computer, a laptop computer, a hand-held computing device, a tablet, or a smartphone, for example, or any other computing device or electronic information display device. In some embodiments, the one or more notification devices 42 may be a part of a wall-mounted thermostat unit.

As will be subsequently described, the processing device 40 may, based on data received from one or more of the sensors 30, 32, 34, 38, diagnose fault conditions (e.g., undercharge conditions, overcharge conditions and/or flow restriction conditions) of the heat-pump system 10, verify a charge level of the heat-pump system 10, and/or provide guidance to a technician during initial installation of the heat-pump system 10 for adding an appropriate amount of working fluid into the heat-pump system 10. Notifications, alerts, updates and/or other information output from the processing device 40 may be transmitted to one or more notification devices 42 and may be accessed or displayed thereon. In some embodiments, the notifications, alerts, updates and/or other information output from the processing device 40 may be transmitted to the notification device 42 via email, text message, instant message, multimedia message. In some embodiments, the notification device 42 may include a mobile application (e.g., a smartphone or tablet application) that provides notifications, alerts, updates, and/or other information based on output from the processing device 40.

With reference to FIGS. 1-3, a method of diagnosing a fault condition when the heat-pump system 10 is in a heating mode will be described in detail. The method may include determining whether a reason for inefficient and/or ineffective operation of the heat-pump system 10 is an undercharge condition (i.e., not enough working fluid in the heat-pump system 10), an overcharge condition (i.e., too much working fluid in the heat-pump system 10), or a flow restriction in the heat-pump system 10 (e.g., a working-fluid-flow restriction in the liquid line or an airflow restriction at the outdoor heat exchanger 20 or at the indoor heat exchanger 16).

At step 110, the return-air temperature sensor 30, supply-air temperature sensor 32, and the liquid-line temperature sensor 34 may detect temperatures at their respective locations and transmit this data to the processing device 40. As described above, detecting and transmitting this data may be done on-demand, intermittently, averaged over a time period, or in real time. At step 120, the processing device 40 may determine a value equal to supply-air temperature minus a liquid-line temperature. When the heat-pump system 10 is operating in the heating mode, the liquid-line temperature may be a temperature detected by the liquid-line temperature sensor 34.

At step 130, the processing device 40 may determine if the value calculated at step 120 (supply-air temperature minus liquid-line temperature) is higher or lower than a first predetermined value. The first predetermined value may correspond to a particular heat pump system and/or may be based on a current outside-air temperature determined by the outside-air temperature sensor 38.

If the processing device 40 determines (at step 130) that the value determined at step 120 is lower than the first predetermined value, the processing device 40 may calculate, at step 140, a value equal to liquid-line temperature minus a return-air temperature. At step 150, the processing device 40 may determine if the value calculated at step 140 (liquid-line temperature minus return-air temperature) is higher or lower than a second predetermined value. The second predetermined value may correspond to a particular heat-pump system and/or may be based on a current outside-air temperature determined by the outside-air temperature sensor 38. If, at step 150, the processing device 40 determines that the value calculated at step 140 is lower than the second predetermined value, then the processing device 40 may, at step 160, send a notification to the notification device 42 indicating that the heat-pump system 10 is undercharged

and working fluid should be added to the heat-pump system 10. If, at step 150, the processing device 40 determines that the value calculated at step 140 is higher than the second predetermined value, then the processing device 40 may, at step 170, determine that the system charge is adequate and/or any system fault may not be related to system charge.

If, at step 130, the processing device 40 determines that the value determined at step 120 is higher than the first predetermined value, the processing device 40 may calculate, at step 180, a value equal to supply-air temperature minus return-air temperature. At step 190, the processing device 40 may determine if the value calculated at step 180 (supply-air temperature minus return-air temperature) is higher or lower than a third predetermined value. The third predetermined value may correspond to a particular heat-pump system and/or may be based on a current outside-air temperature determined by the outside-air temperature sensor 38. If, at step 190, the processing device 40 determines that the value calculated at step 180 is lower than the third predetermined value, then the processing device 40 may, at step 200, send a notification to the notification device 42 indicating that there is a working fluid flow restriction in the heat-pump system 10. If, at step 190, the processing device 40 determines that the value calculated at step 180 is higher than the third predetermined value, then the processing device 40 may, at step 210, send a notification to the notification device 42 indicating that the heat-pump system 10 is overcharged and an amount of working fluid in the heat-pump system 10 should be reduced.

In addition to diagnosing a fault of the heat-pump system 10, the processing device 40 may perform the above method steps to verify a charge of the heat-pump system 10 on-demand or at predetermined time intervals, for example. If the processing device 40 determines that the heat-pump system 10 is overcharged, undercharged and/or some other fault condition exists, the processing device 40 may send an appropriate notification to the notification device 42, as described above.

The processing device 40 and notification device 42 may also be used by a technician to perform an initial charge of the heat-pump system 10 during the initial installation of the heat-pump system 10 into the house or building. That is, real time supply-air, return-air, liquid-line and outside-air temperature measurements can be processed by the processing device 40 and real-time feedback from the processing device 40 can be provided to the technician via the notification device 42 that indicates when the heat-pump system 10 has reached an optimum charge level (i.e., when the technician should stop adding working fluid to the heat-pump system 10).

For example, the processing device 40 may monitor (in real time) a value of liquid-line temperature minus return-air temperature. This value may continue to increase as the technician adds working fluid during the initial system charge until an optimum charge level is achieved. Once the optimum charge level is achieved, adding more working fluid to the heat-pump system 10 may cause the value of liquid-line temperature minus return-air temperature to decrease. Therefore, the processing device 40 and notification device 42 may notify the technician as soon as the value of liquid-line temperature minus return-air temperature starts to decrease. When the technician receives this notification, he or she may stop adding working fluid to the heat-pump system 10.

The first, second and third predetermined values described above may be chosen to correspond to a particular

heat-pump system and may be determined through experimentation or from look-up tables, for example.

In this application, including the definitions below, the term module may be replaced with the term circuit. The term module may refer to, be part of, or include an Application Specific Integrated Circuit (ASIC); a digital, analog, or mixed analog/digital discrete circuit; a digital, analog, or mixed analog/digital integrated circuit; a combinational logic circuit; a field programmable gate array (FPGA); a processor (shared, dedicated, or group) that executes code; memory (shared, dedicated, or group) that stores code executed by a processor; other suitable hardware components that provide the described functionality; or a combination of some or all of the above, such as in a system-on-chip.

The foregoing description is merely illustrative in nature and is in no way intended to limit the disclosure, its application, or uses. The broad teachings of the disclosure can be implemented in a variety of forms. Therefore, while this disclosure includes particular examples, the true scope of the disclosure should not be so limited since other modifications will become apparent upon a study of the drawings, the specification, and the following claims. As used herein, the phrase at least one of A, B, and C should be construed to mean a logical (A or B or C), using a non-exclusive logical OR. It should be understood that one or more steps within a method may be executed in different order (or concurrently) without altering the principles of the present disclosure.

The foregoing description of the embodiments has been provided for purposes of illustration and description. It is not intended to be exhaustive or to limit the disclosure. Individual elements or features of a particular embodiment are generally not limited to that particular embodiment, but, where applicable, are interchangeable and can be used in a selected embodiment, even if not specifically shown or described. The same may also be varied in many ways. Such variations are not to be regarded as a departure from the disclosure, and all such modifications are intended to be included within the scope of the disclosure.

What is claimed is:

1. A method of monitoring a heat-pump system having indoor and outdoor heat exchangers, a compressor adapted to circulate a working fluid between the indoor and outdoor heat exchangers, and an expansion device disposed between the indoor and outdoor heat exchangers, the method comprising:

receiving a first air temperature value of air upstream of the indoor heat exchanger from a return-air temperature sensor when the heat-pump system is operating in the heating mode;

receiving a second air temperature value of air downstream of the indoor heat exchanger from a supply-air temperature sensor when the heat-pump system is operating in the heating mode;

receiving, from a working-fluid temperature sensor, a working-fluid temperature value of working fluid flowing between the expansion device and the indoor heat exchanger when the heat-pump system is operating in the heating mode;

determining, using a processor, a first difference between the second air temperature and the working-fluid temperature and a second difference between the second air temperature and the first air temperature; and

determining, using the processor, a working-fluid-charge condition of the heat-pump system based on a first comparison of the first difference with a first predetermined value and a second comparison of the second difference with a second predetermined value.

2. The method of claim 1, further comprising determining, using the processor, a third difference between the working-fluid temperature and the second air temperature.

3. The method of claim 2, wherein determining the working-fluid charge condition is further based on a third comparison of the third difference with a third predetermined value.

4. The method of claim 3, further comprising generating a first alert with a notification device indicating that a fault condition of the heat-pump system is related to the working-fluid-charge condition.

5. The method of claim 4, further comprising generating a second alert with the notification device indicating that the fault condition of the heat-pump system is unrelated to an amount of working fluid in the heat-pump system.

6. The monitor of claim 5, further comprising generating a third alert indicating that the fault condition of the heat-pump system is related to a working fluid undercharge condition if the third difference is lower than the third predetermined value.

7. The monitor of claim 6, further comprising generating a fourth alert indicating that the fault condition of the heat-pump system is unrelated to an amount of working fluid in the heat-pump system if the third difference is higher than the third predetermined value.

* * * * *