

STOVES

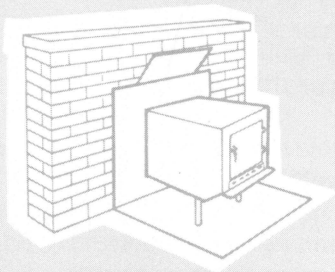

COOPERATIVE EXTENSION SERVICE
THE OHIO STATE UNIVERSITY

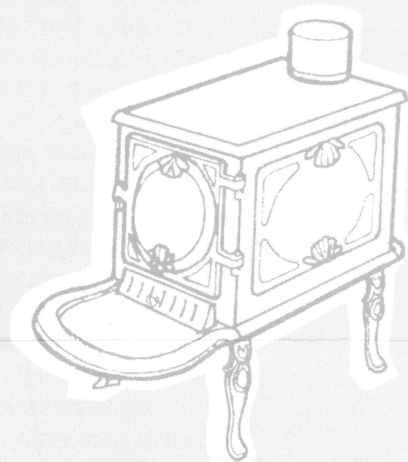
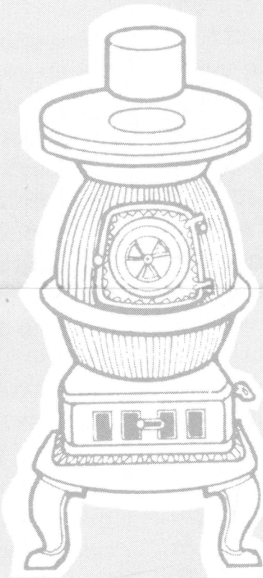
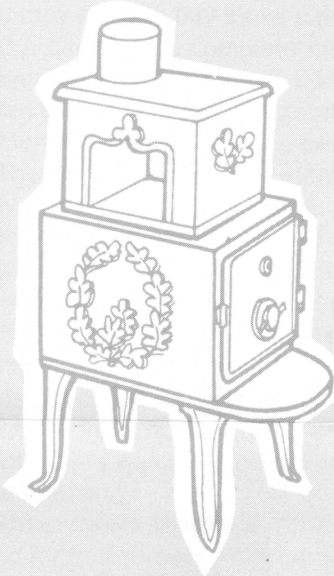
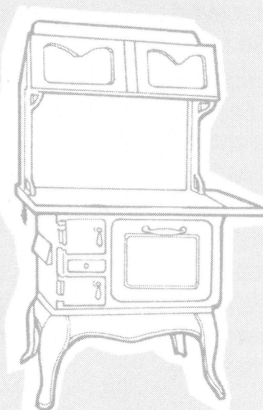
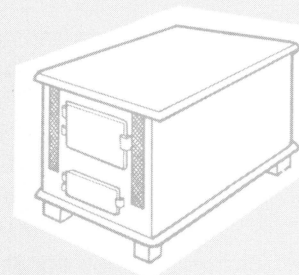

STOVES

Before purchasing a stove, first decide how it will be used. Will it be for

- emergencies such as power outages?
- supplemental heat to the main furnace or to heat one or two rooms?
- total heating of the entire house?
- conversation and occasional use?

Consider the total cost of installing a stove. Remember you may need to buy stove pipe, floor and wall protection and a chimney. A complete installation can cost several thousand dollars which will take many years to pay back. Often this money is better spent on insulating and weather tightening the house before switching fuels.

There are thousands of manufacturers of woodburning stoves throughout the world. Appearance, style, finish, construction, materials, and weight are some of the characteristics which need to be evaluated. Durability of welding, sharpness of cabinet or stove edges which may scratch or cut people, and ability to burn wood efficiently for maximum heat are other factors to consider. Some persons are concerned with creosoting of the stove pipe and chimney from slow burning airtight stoves while others want stoves which will burn wood for a long time and with little attention.

Sheet metal stoves of relatively thin gauge have been used for many years for heating. They are relatively inexpensive but have a shorter life than plate steel or cast iron stoves. They will quickly heat a room, but they also cool rapidly when the fire dies down. If occasional quick heating is needed, such as for a cabin, a garage, or emergency use thin walled stoves are appropriate.

Good draft control is very important to control the rate of heating. Thin wall stoves should never be heated red hot as they tend to warp and burn through. Examine these stoves frequently for thin spots.

Plate steel stoves made from steel $\frac{1}{8}$ inch or thicker are also available. These welded stoves hold heat longer. Many of these stoves are lined with firebrick to protect the metal and to provide more even heat.

Cast iron stoves warm up more slowly and retain heat longer than sheet metal stoves. However, if other design and operating practices are equal, the same amount of heat will be delivered to the room. Cast iron holds up well under heat, has a long life, spreads the heat away from hot spots in the fire, and generally does not warp. It cracks easily if dropped. Used cast iron stoves should be thoroughly inspected by persons knowledgeable in their construction to determine if there are any cracked, broken, or missing parts, or areas that are warped or thin.

Stove Types

A trip to a local stove distributor will show you that there are many types, styles and sizes available. These have been developed over the years by manufacturers to meet a particular purpose.

The **combination type stove** is similar to the Franklin stove in its use. It can be operated as an open fireplace or a closed stove. Most of these are manufactured of cast iron and are large enough to heat one or two rooms. Some of the stoves are built with airtight doors and good draft control and can achieve 50–60 percent efficiency.

A **box stove** is just what the name indicates, a box. It can have either a square or rectangular cross-section and is most often supported on legs. The wood is placed on a bed of sand or ashes as the stove does not usually have a grate. These stoves are available in many sizes, in airtight construction and with baffles or warming boxes to increase their efficiency. In the larger sizes, the fire box will take firewood in 24 inch lengths.

The **parlor stove** was designed to heat a single room. It usually has a double steel wall or jacket around it which gives a lower surface temperature than a single wall stove. It is often available with a thermostat that regulates the drafts and thereby the temperature in the room.

The **pot belly stove** is most often associated with railroad stations and country houses. It is usually made of cast iron and often has ornate designs and trim. The small diameter firebox requires that wood be cut in short lengths. The added height allows better burning of the volatile gases.

Fireplace stove: Several stoves have been developed to increase the efficiency of the fireplace. The stove is attached to a piece of sheet metal that fits over the face of the fireplace. This makes a simple installation that eliminates the need for another chimney. Usually these stoves have a built-in damper so the fireplace damper can remain open all the time.

Kitchen stoves: A range can be used for cooking as well as heating. Of course, a range warms the kitchen whenever it is used, which can be uncomfortable in summer. Most ranges are of cast iron construction and will burn either wood or coal. When wood is burned, the pieces need to be short and split fairly small.

Circulating stoves: Most stoves transfer heat to the room by radiating heat from the hot surface of the stove. A few manufacturers provide a double wall stove with air vents in the top and bottom of the outer wall. Air circulates

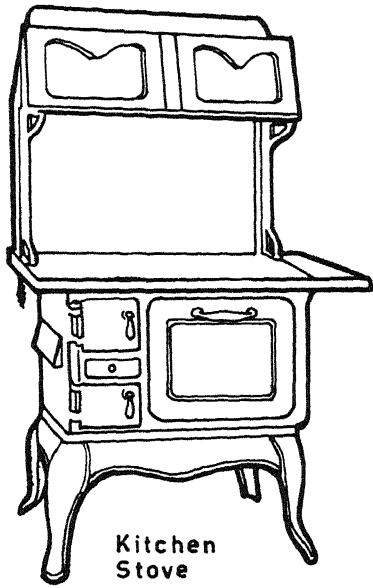

Kitchen Stove

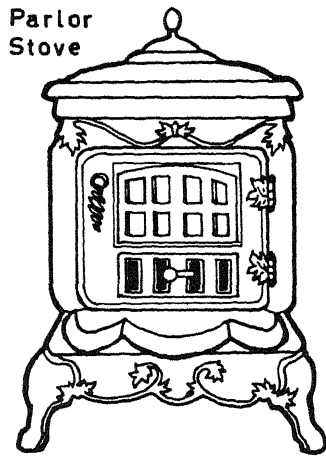

Parlor Stove

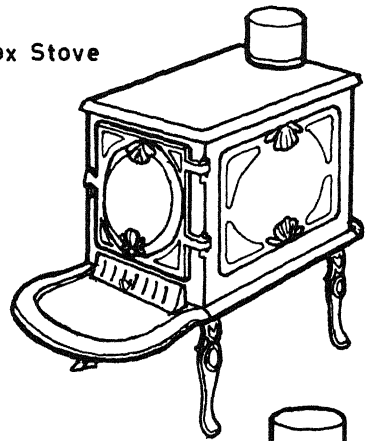

Box Stove

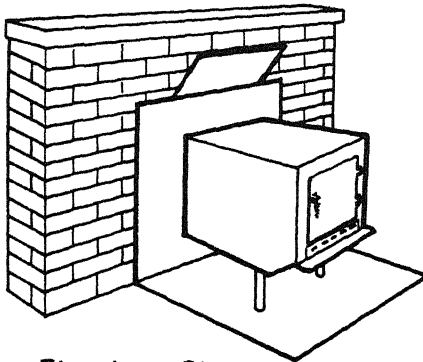

Fireplace Stove

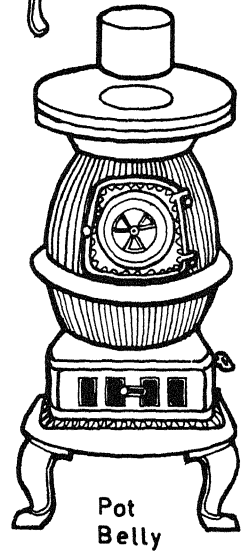

Pot Belly

STOVES

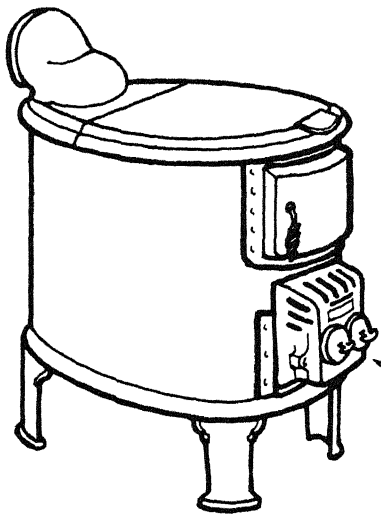

Air-tight Stoves

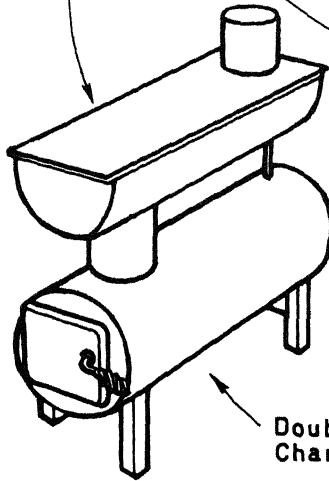
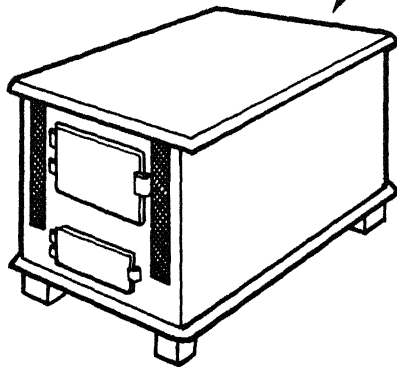

Double Chamber

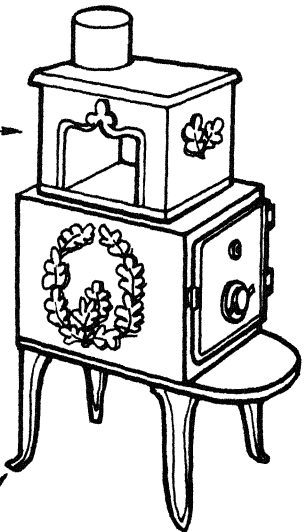

between the wall of the stove by natural movement. Much of the heat produced by the stove is transferred to the room by the heated air. The outer surface of a circulating stove is not as hot as a radiant stove.

Efficiency

The stove characteristic that usually receives the most attention is efficiency. Efficiency is the percentage or fraction of chemical energy available from the wood that heats the room. Efficiency depends on:

- the wood used
- the skill of the operator
- the design of the stove and chimney.

Wood varies in size, density and moisture content; it is not a simple, uniform fuel like natural gas, propane or fuel oil. Gas and oil burners uniformly mix fuel with oxygen, while various size chunks of wood are periodically dumped into a firebox. Over the years many stove designs have been developed to overcome the difficulties inherent in wood-fueled combustion.

Wood-fueled heaters operate most efficiently when they are burning at nearly full capacity. In Spring and Fall it is

difficult to operate wood stoves at full output to create high enough temperatures for good combustion and heat transfer without overheating the room. Gas and oil can be burned at fairly high efficiencies because the burner still operates at full output but the fuel can easily be started and stopped.

Combustion Efficiency

When burning wood, combustion of the volatiles can supply a majority of heat from the burning process. Fireplaces, which are about 10% efficient, do not retain the gases long enough to burn them completely. To burn these gases a long flame path, heated above 1100°F, is required.

Much greater efficiencies can be achieved by burning wood in a stove. The walls and top of a simple box stove can be heated sufficiently to aid in burning the volatile gases. Some stoves have a baffle adjacent to the firebox. The baffle, heated by the fire, creates a long hot flame path necessary to efficiently burn the volatile gases. Stoves with no baffle are called updraft or diagonal draft stoves. Baffles can create a downdraft, a crossdraft or an S draft.

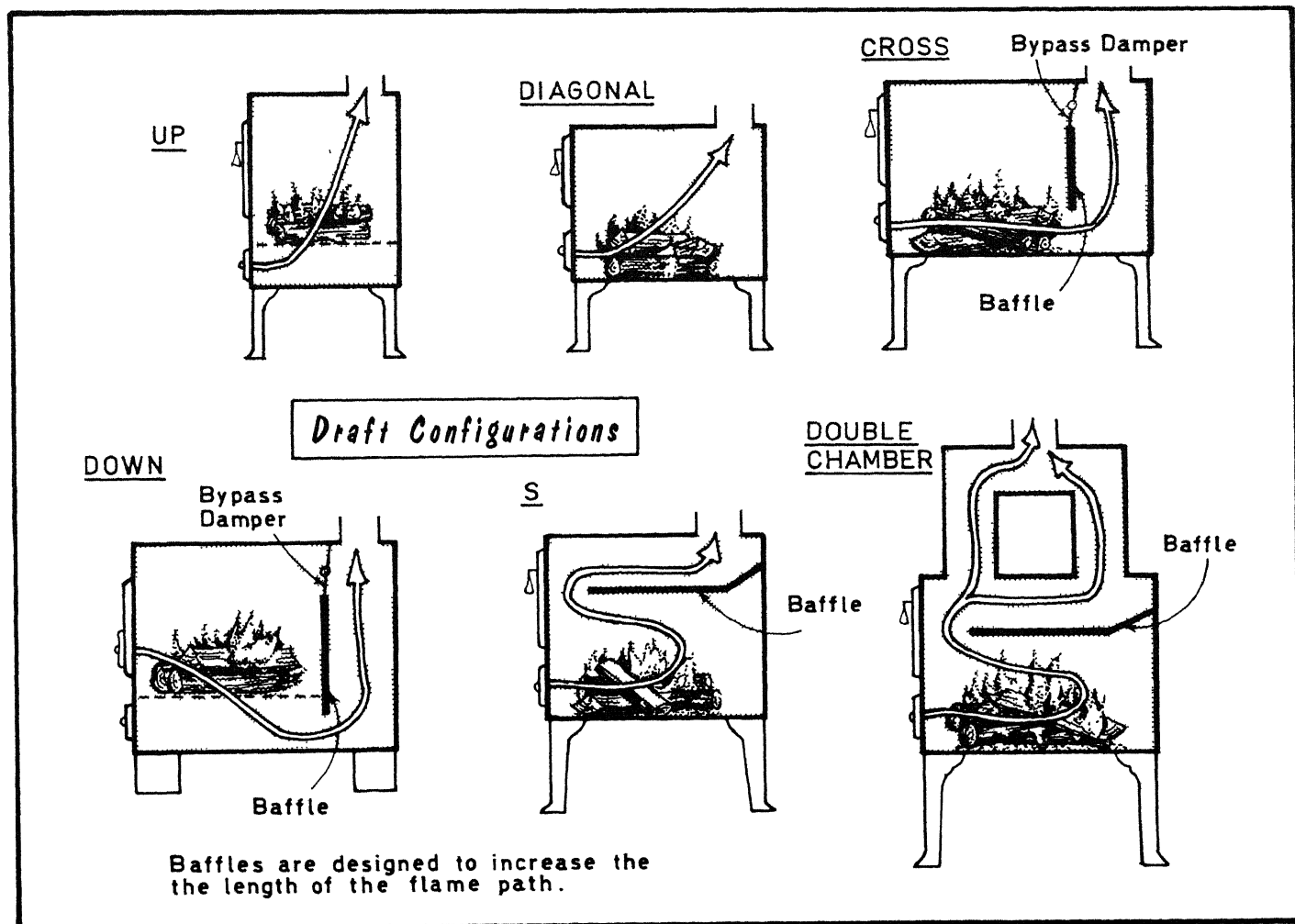

STYLE:	EFFICIENCY
Standard Fireplace	up to 10%
Fireplace with metal liners or tube grates	up to 20%
Simple Updraft Stove, Franklin stove	up to 30%
Airtight Stoves	up to 45 - 60%
Ordinary Furnace (burning maple at 20% moisture content)	up to 50 - 60%
Gas or Oil fired Furnace	up to 65 - 80%

Heat Transfer Efficiency

The ability of a stove to transfer heat to the surroundings is probably more important to overall efficiency than combustion efficiency. The surfaces of the stove must be warmed to radiate heat. Updraft stoves typically burn hotter than downdraft stoves; downdraft and S draft stoves, on the other hand, usually are larger to accommodate a baffle, so they have more surface to radiate heat. Fire brick lining in the fire box retains a hotter fire and provides protection for the stove walls, but it reduces the radiation from that part of the stove.

Draft Control

A comfortable room temperature is most easily maintained by controlling the rate that the fire consumes the wood in the stove. The loose fitting doors on a Franklin stove provide some control of the fire. However, much better control is achieved if the stove door seals the opening and the air flow into the stove is controlled by an adjustable vent. Stoves constructed in this manner are called airtight stoves. On some stoves, this air inlet is controlled by a thermostat.

The primary air supply may not be adequate or in the correct position to supply air to support the combustion of the volatile gases, so some stoves have an additional air vent to introduce secondary air above the flame. The amount of secondary air admitted is critical for efficient operation. If too little air is admitted, incomplete combustion will result. If too much air is admitted, the gases will be cooled, affecting combustion and heat transfer.

Stove Heating Capacity

Many manufacturers rate their stoves by either the number of cubic feet or the number of rooms the stove will heat. Any capacity rating must be used cautiously. In colder areas or poorly insulated houses, less area will be heated. In addition, heat movement into more than one room of the house may be very poor. Registers and ducting for hot air flow and a cold air return may be necessary to improve warm air movement. Unless the rooms are very open, attempting to heat more than one room with a stove may result in uneven temperatures and cold drafts along the floor.

Outside Air Inlets

A further complication to efficient stove operation has occurred in tightly constructed, well insulated houses. These houses may not have enough air leakage to supply air to the wood stove, causing poor burning and smoke. Opening a nearby window normally solves the problem, but this lets in cold air that, in effect, lowers heating efficiency.

J. W. Shelton in the book, *The Woodburners Encyclopedia* states:

Where feasible, the simplest way to get combustion air directly to the wood heater is through an opening in the floor under or in front of the stove (or fireplace), which provides an air passage from a basement or crawl space. The size (area) of the passage should be roughly the same as the flue. Alternatively, air can be ducted directly from an outside wall of the house to the heater, either via the basement or through a wall behind the stove. It is probably best to actually attach an outside air duct directly to the stove's air inlet, but this is frequently inconvenient.

Feeding outdoor combustion air to a wood heater will usually decrease the net energy efficiency of the system, due both to decreased heat transfer from the stove and to the larger heating needs of the house due to the new hole in it. A damper should be installed to help limit the outside air flow when it is not needed, but some leakage is virtually inevitable. The increase in comfort from eliminating part of the floor draft may be worth using a little extra energy.

INSTALLATION

House fires occur when stoves are improperly installed or carelessly operated. Most fires are caused when combustibles are too close to a hot stove, by escape of hot gases or flames through a crack in a chimney, by conduction of heat from a chimney into combustible materials, or by sparks or coals escaping from a stove.

Some states recommend that you consult the local building official and fire marshal and notify your insurance agent before installing a stove. The National Fire Protection Association (NFPA) has developed standards that are the basis for many local building codes. For maximum safety locate a stove or heater at least 36 inches from woodwork, other combustible materials or furniture. A stove pipe should not be closer than 18 inches to the ceiling.

Table 3. Minimum Clearances from Combustible Walls and Ceilings*

Type of Protection	Stove Type		Stove Pipe
	Radiant	Circulating	
None	36"	12"	18"
1/4" Asbestos Millboard, spaced out 1"	18"	6"	12"
28 gage sheet metal, spaced out 1"	12"	4"	9"
28 gage sheet metal on 1/8" asbestos millboard, spaced out 1"	12"	4"	9"

*From National Fire Protection Association No. 89M, 1971.

Wall Protection

The recommended clearances can be reduced considerably if combustible walls and ceilings are protected with asbestos millboard or 28 gauge sheet metal spaced out 1 inch from the combustible wall. The spacers should be constructed from a non-combustible material. Provide a 1 inch air gap at the bottom of the asbestos millboard or metal panel. Air circulating behind the panel will cool the panel and the wall.

Brick or stone provide little or no protection for a combustible wall because they are good conductors of heat.

Asbestos millboard is a different material from asbestos cement board.

Floor Protection

The material used to protect the floor should extend 6 to 12 inches beyond the stove on three sides and 18 inches beyond the side where the wood is added.

All floors on which stoves are set, except concrete, must be protected from both heat of the fire and hot coals falling out when fuel is added. Metal with asbestos backing and asbestos millboard are non-combustible materials used for floor protection. Slate, brick, marble chips and colored pebbles can also be used; but, unless they are mortared in place with no gaps, metal or asbestos millboard must be installed between them and a wood floor. A two inch layer of sand or ashes, or bricks laid in the bottom of the stove help prevent overheating of combustible flooring.

The air space between the bottom of the stove and the floor covering is important; stoves should be on legs at

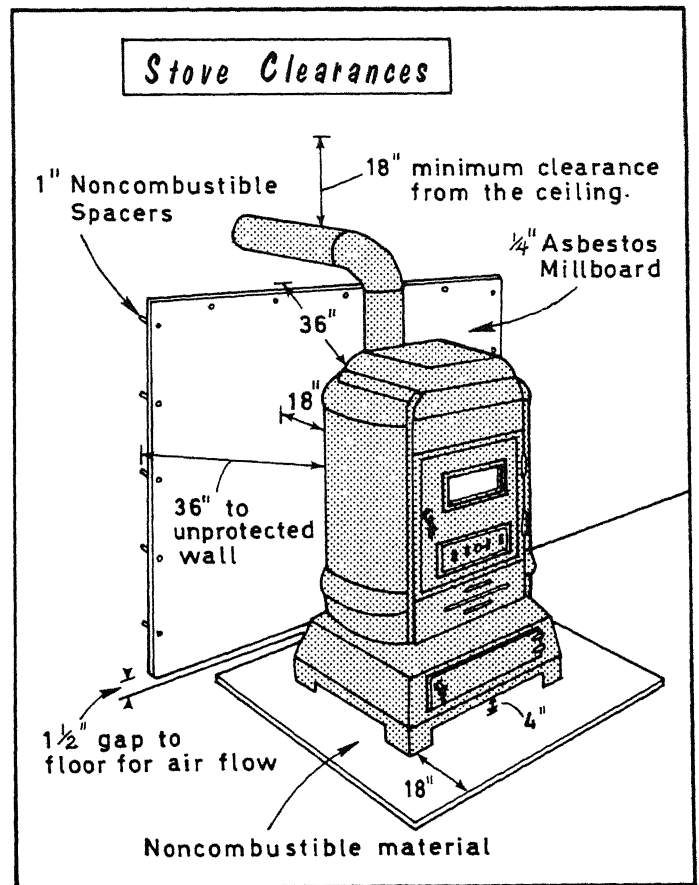

least 4 inches high. Eight to ten inch legs provide more air space and less heat will be transferred from the stove to the floor. Be certain that both floor and wall protection extend far enough for adequate protection when a stove or Franklin type fireplace is set on a hearth or inside a stone or brick fireplace.

Stove Pipe

The stove or smoke pipe used to connect the outlet of the firebox to the chimney is sold in 24 inch lengths. Building codes require stove pipe to be 24 gauge or thicker; higher gauge numbers indicate thinner metal. The diameter of the stove pipe used should be the same diameter as the firebox outlet. Most wood stoves use either a 6 or 8 inch smoke pipe. Using stove pipe that is smaller in diameter than the firebox outlet will reduce combustion efficiency and possibly cause improper draft.

Most stove installations should have a damper either built into the stove or in the pipe near the stove to control draft and loss of volatile gases. Check the recommendation of the stove manufacturer.

Stove pipes should be as short and as straight as possible and enter the chimney higher than the outlet of the stove's firebox. The maximum length of the pipe should be less than ten feet.

Avoid horizontal runs. Instead, use 45° angles to create an upward slope in the flue connector pipe. Try to have no more than one right angle turn between the stove and chimney.

Running a stove pipe out a window and up the outside wall of the house is a dangerous practice. Wood burners sometimes recommend long spans of single thickness stove pipe as a heating device. This idea had some merit when used with inefficient stoves where much of the heat went up the pipe. Airtight stoves, however, are more efficient and this practice may cause rapid creosote buildup.

Long stove pipes and those with restrictions should be cleaned frequently to prevent creosote buildup and possible chimney fires.

Where a smoke pipe must pass through a wall, provide an opening with at least 6" of clearance from all wood framing and protect it with a double wall ventilated thimble. A thimble about two inches larger than the pipe is used for the installation of a flue for a gas furnace and is not adequate for a wood stove installation. The entire length of the smoke pipe must be easily inspected, firmly fastened at the joints and kept free of all combustible materials.

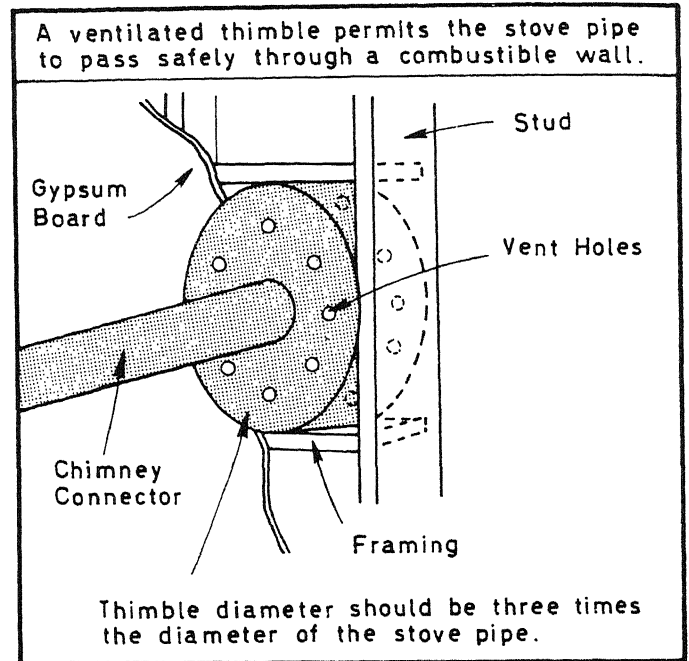

Chimneys

The chimney has two main purposes: to create a draft and to evacuate the gases of combustion. It also discharges some of the heat generated by the fire. The higher the chimney or the larger its cross sectional area, the greater the flow capacity. However, chimney area is more important in effecting capacity than chimney height.

Prefabricated Chimneys

Prefabricated chimneys are easier to erect than masonry ones. Tests at the National Bureau of Standards have shown that metal and masonry chimneys differ little with respect to draft when used under similar conditions. A key point is that metal prefabricated chimneys must be UL listed as ALL FUEL chimneys. Do not use the UL listed "Vent" as it is not insulated or ventilated enough for wood or coal burning. The standard sections are 18" and 30" long and are available in a variety of inside diameter sizes. The sections lock together and no screws or special tools are needed for assembly.

There are two types of metal prefabricated chimneys, an insulated chimney and a triple wall chimney. Insulated prefabricated chimneys are made of a stainless steel outer casing, one inch of insulation and a stainless steel inner liner.

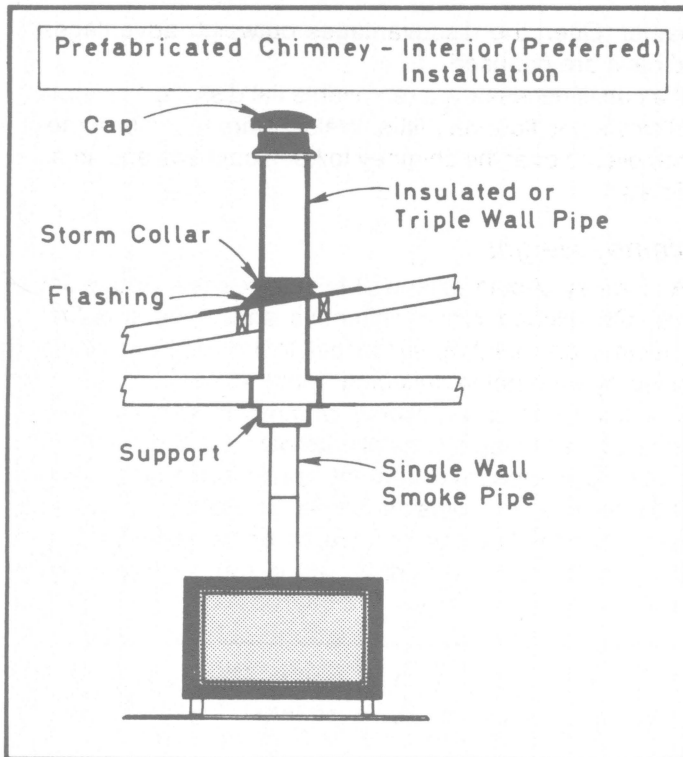

Triple wall chimneys are constructed so that outside air passes down between the outer walls of the triple wall chimney and up along the interior wall. This movement of air cools the chimney.

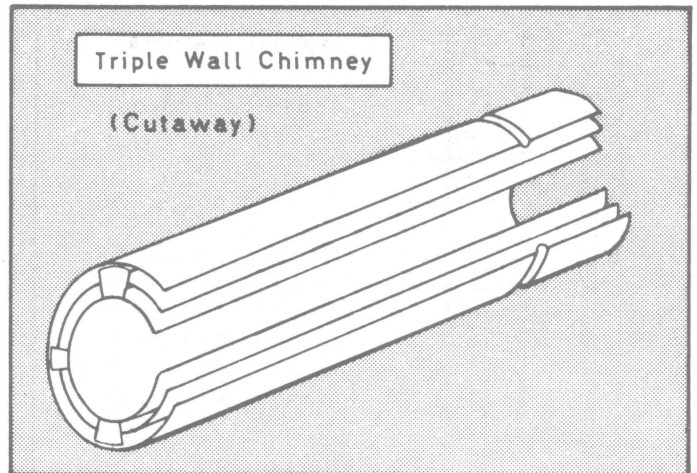

Masonry Chimneys

The material cost for masonry chimneys is much less per foot of length than the steel prefabricated chimneys, but much more labor is required for construction.

Masonry chimneys act as large heat sinks to radiate warmth into the room after the stove cools — if it is inside the house and not on an outside wall. An inside chimney absorbs heat from the fire or stove and radiates it back into the living space.

Install the stove pipe so it enters the masonry chimney horizontally. It should be installed flush with and not extend into the flue lining. The wall at the chimney connection must be protected in one of the following ways:

1. If no thimble is used the stove pipe must be securely fastened to the chimney with a high temperature cement. Combustible material within 18" of the pipe must be removed. For a 6" diameter pipe, this requires a $6" + 2 \times 18" = 42"$ diameter hole in a combustible wall. The hole may be closed in or covered with non-combustible materials such as masonry, asbestos millboard, or sheet metal.

2. Use a metal thimble or a burned fire-clay thimble and surround it with at least 8" of fireproofing material such as fiberglass insulation or brick. Cover the opening with non-combustible materials such as asbestos millboard or metal. A small gap should be left between the thimble and the covering material to allow either the house or chimney to settle slightly and not crack the thimble. The gap can be covered with a stove pipe flange.

3. Install an insulated ALL FUEL chimney pipe as a thimble. Then only a 2" clearance between the chimney and combustible materials is required. Cover the gap between the wall and the stove pipe with a stove pipe flange.

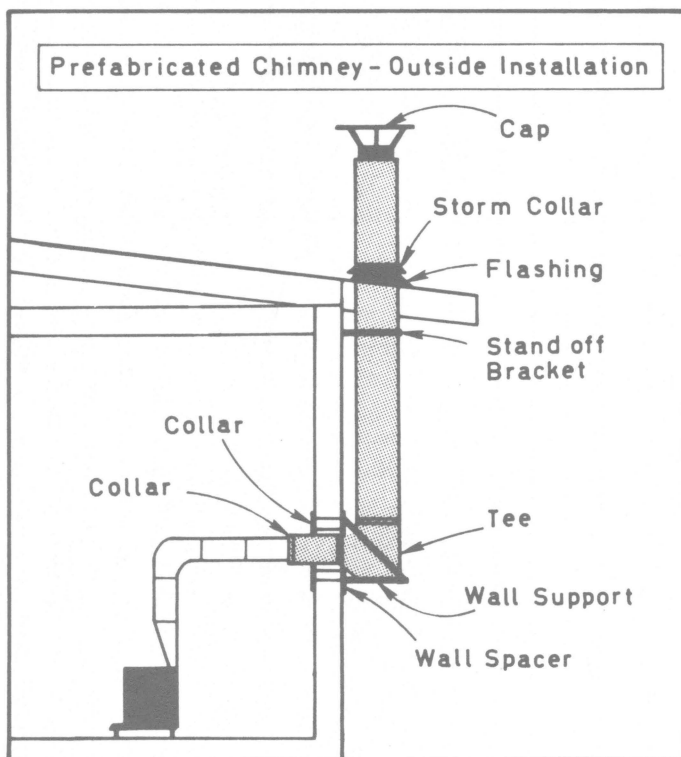

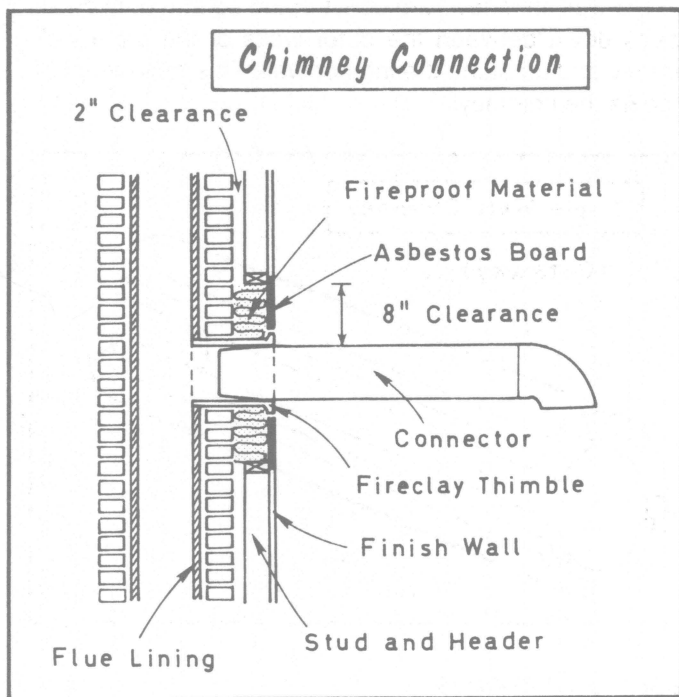

Two or More Connections to One Chimney

National Fire Protection Association Standards state that a stove chimney connector is not permitted to be connected to a flue serving a fireplace—a fireplace must have its own individual flue. Franklin stoves have an open front and should be treated as fireplaces in this respect.

Room heaters, cook stoves, etc., should not be connected to a common flue. The reason is that flue gases and sparks may pass from one flue opening into another. Besides, multiple connections sometimes result in unsatisfactory operation.

If two or more stoves, such as a room heater and a cook stove, are connected to the same chimney flue, despite the recommendations against doing so, the connections must enter the chimney at different elevations. A common flue must, of course, be of sufficient size to provide an adequate draft for all the stoves connected to it.

Chimney Caps

A chimney cap is sometimes used to help prevent down drafts where the chimney's top is subject to wind turbulence caused by roof shape, trees, terrain, or other buildings and to keep out rain and snow. Any cap adds resistance to the system and reduces the draft. Mechanical turbines, revolving ventilators and other mechanical devices are subject to failure from creosote buildup and

weather. Often the disadvantages outweigh advantages and caps are not used.

If a cap is necessary, a removable flat disk cap is simple and slows gas flow very little. Welded wire fabric is sometimes placed over the chimney to keep out birds and small animals.

Chimney Height

A chimney should extend at least three feet above flat roofs. On pitched roofs, chimneys should be two feet higher than any point within ten feet, to prevent down drafts caused by wind being deflected from the roof.

The flue lining of a masonry chimney is extended four inches above the top course of brick or stone and the top of the chimney capped with cement mortar. The mortar is two inches thick at the outside edges of the chimney and sloped up to the flue lining to direct air currents upward at the top of the flue and to drain water from the top of the chimney.

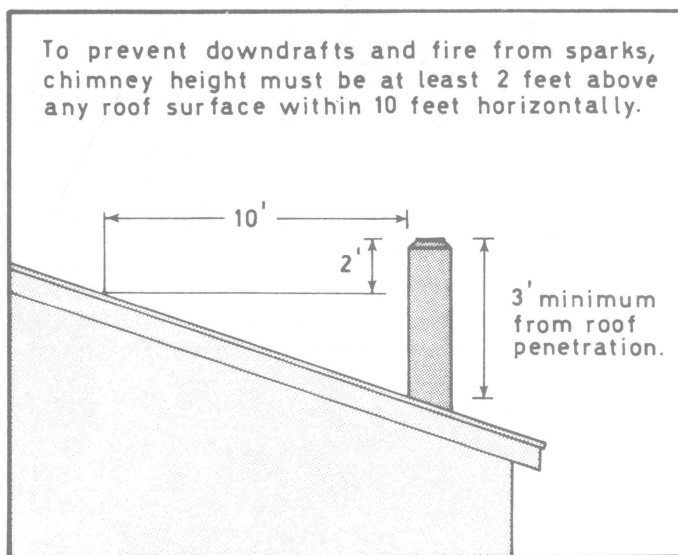

To prevent downdrafts and fire from sparks, chimney height must be at least 2 feet above any roof surface within 10 feet horizontally.

Smoky Fires

One of the most common problems of wood stove installations is smoky fires. Smoke may come into the room through the openings in the stove or the fire may not burn properly because it lacks an adequate draft. Six main causes and cures are:

(1) **Wet wood.** Green or wet firewood causes smoke problems as much of the heat of the fire is used to dry the wood. The cure is to keep a hot fire going and to use seasoned dry wood. If green or wet wood must be burned, split it finer and mix it with dry wood. Soft wood may cause smoky fires because of the resin in the wood.

(2) **Flue too small.** The stove pipe and chimney flue must be large enough to carry the smoke and gases outside. Follow manufacturers' recommendations for stove pipe size. Do not reduce the pipe size between the stove and chimney connection. An 8" × 8" or 8" × 12" chimney flue is usually the minimum size for a chimney. If two wood stoves are connected to one chimney, a larger flue may be needed.

(3) **Flue too large.** Many older houses have a large central chimney with several fireplaces and flue openings. If this chimney is used with only one stove or heater there may not be adequate draft to keep the column of smoke rising. By reducing the cross sectional area of the top of the chimney or installing a stove pipe through the center of the flue, the smoke problem should be solved.

(4) **Obstructed flue.** Often stove pipes or flues become partially filled with soot and creosote, especially with small or slow fires. Cure this problem by checking flues and stove pipes once a month during the heating season and clean them when a buildup starts to occur.

(5) **Downdrafts.** Nearby trees, buildings or roof projections often cause downdrafts during windy periods. Raising the height of the chimney, removing the obstruction or placing a cap on the chimney may correct the problem.

(6) **Lack of oxygen.** A fire needs oxygen to burn properly. In a tight, well insulated house, infiltration has been reduced to a minimum. This lack of air can sometimes cause smoke to be pulled back into the house through an adjacent flue. Opening the basement door or a nearby window an inch or installing an air intake to the stove area will generally eliminate this problem.

Stove Installation Checklist

Before starting the first fire in your stove use this checklist to be sure that it is safely installed.

- ___1. The stove does not have broken parts or large cracks that make it unsafe to operate.
- ___2. A layer of sand or brick has been placed in the bottom of the firebox if suggested by the stove manufacturer.
- ___3. The stove is located on a non-combustible floor or an approved floor protection material is placed under the stove.
- ___4. Floor protection extends out 6 to 12 inches from the sides and back of the stove and 18 inches from the front where the wood is loaded.
- ___5. The stove is spaced at least 36 inches away from combustible material. If not, fire-resistant materials are used to protect woodwork and other combustible materials.
- ___6. Stove pipe of 22 or 24 gauge metal is used.
- ___7. The stove pipe diameter is not reduced between the stove and the chimney flue.
- ___8. A damper is installed in the stove pipe near the stove unless one is built into the stove.
- ___9. The total length of stove pipe is less than 10 feet.
- ___10. There is at least 18 inches between the top of the stove pipe and the ceiling or other combustible material.
- ___11. The stove pipe slopes upward toward the chimney and enters the chimney higher than the outlet of the stove firebox.
- ___12. The stove pipe enters the chimney horizontally through a fire clay thimble that is higher than the outlet of the stove firebox.
- ___13. The stove pipe does not extend into the chimney flue lining.
- ___14. The inside thimble diameter is the same size as the stove pipe for a snug fit.
- ___15. A double walled ventilated metal thimble is used where the stove pipe goes through an interior wall.
- ___16. The stove pipe does not pass through a floor, closet, concealed space or enter the chimney in the attic.
- ___17. A UL approved ALL FUEL metal chimney is used where a masonry chimney is not available or practical.
- ___18. The chimney is in good repair.
- ___19. The chimney flue lining is not blocked.
- ___20. The chimney flue lining and the stove pipe are clean.
- ___21. A metal container with tight fitting lid is available for ash disposal.
- ___22. The building official or fire inspector has approved the installation.
- ___23. The company insuring the building has been notified of the installation.

FURNACES

Woodstoves are good for heating small, open houses or one or two rooms. But most houses are designed for central heating with a furnace. Wood burning furnaces are large enough to heat an entire house. Some are made to fit a hot air duct system, others a hot water system. If you have a good wood supply and don't mind the hard work of cutting, splitting, stacking and feeding the wood, a furnace may be a good investment.

Because of the large fuel capacity and controlled burning, most furnaces require stoking no more often than once every 10 hours and sometimes as little as once every 24 hours. Some of these units have a storage magazine like a hopper, which holds a large charge of wood and feeds it slowly into the combustion zone. Others have extremely

large fireboxes that permit the stoking of large quantities of large chunks of wood (as large as 13 inches in diameter and 3 feet long). Though burning large chunks is not as efficient as burning small sticks, the saving in cost of fuel preparation is great.

All furnaces are thermostatically controlled. When the thermostat is not calling for heat, the primary air supply is very low so the fire will continue with a very low heat output. When heat is demanded by the thermostat, the primary and secondary air supplies are fully opened. The fire will burn at a high rate, with near complete combustion. On some furnaces, primary and secondary air is supplied by a blower. The hot gases of combustion then pass through a heat exchanger to heat the air or water used to heat the house. Usually another blower forces air from the house through the exchanger. This type of furnace can be quite efficient.

In addition to cutting the wood and stoking the fire, a wood furnace requires more maintenance than a gas or oil burning one. Ashes must be removed and the chimney must be cleaned periodically. The boiler or heat exchanger may need cleaning to remove any deposits. Before purchasing a wood burning furnace, you should first talk to someone who already has one to learn more about how well they operate.

Most people want to keep their house above freezing even when they are not at home to keep the fire burning. A combination wood and oil heat system or auxiliary electric heat can be installed. Many wood burning furnaces come equipped, or can be equipped, with thermostatically controlled oil burners; so you do not have to tend the fire every day.

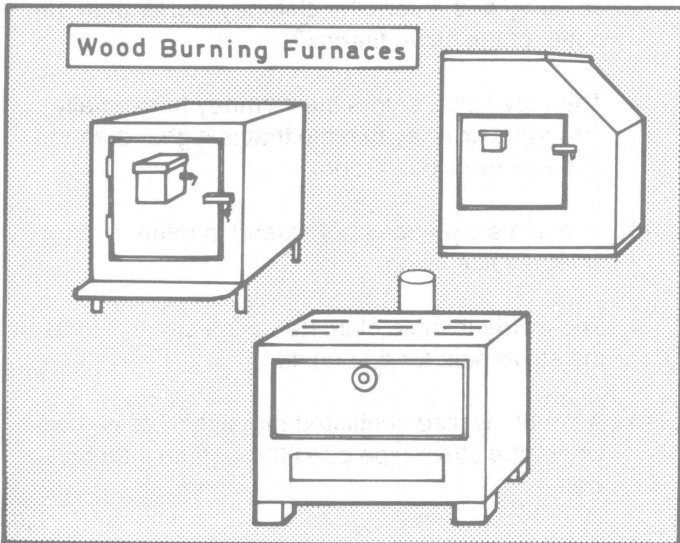



The information in this leaflet has been reprinted from the publication, "Burning Wood," by the Northeast Regional Agricultural Engineering Service, Cornell University, Ithaca, NY 14853

10/77 — 10M

Issues in furtherance of Cooperative Extension work, acts of May 8 and June 30, 1914, in cooperation with the U.S. Department of Agriculture, Roy M. Kottman, Director of the Cooperative Extension Service, The Ohio State University.

By Roger A. Miller
Extension Agricultural Engineer

Stages of Combustion	
<p>1st Stage</p> 	<p>The wood is heated to evaporate and drive off moisture.</p> <p>This heat <u>does not</u> warm the stove or room.</p>
<p>2nd Stage</p> <p>500°F - 1100°F</p> 	<p>The wood starts to break down chemically at 500°F and volatile matter is vaporized.</p> <p>These vapors contain between 50-60% of the heat value of the wood.</p> <p>At 1100°F these vapors burn. This high temperature must be maintained for <u>maximum efficiency of combustion</u>.</p>
<p>3rd Stage</p> <p>over 1100°F</p>  <p>charcoal</p>	<p>Following the release of volatile gases, the remaining material is <u>charcoal</u>, which burns at temperatures exceeding 1100°F.</p>