

# Utilising Object Tracking For The Performance Analysis Of Difficult Airway Equipment - A Shape Retention Testing System (SRTS)

F L Siena<sup>1</sup>, P J Breedon<sup>1</sup>, J Armstrong<sup>2</sup>, P M Watts<sup>1</sup>, K Inkpin<sup>2</sup>, A Norris<sup>2</sup>, P Marsh<sup>3</sup>

<sup>1</sup>Medical Design Research Group, Nottingham Trent University,  
50 Shakespeare Street, Nottingham, NG1 F4Q, United Kingdom

<sup>2</sup>Anaesthetic Department, Nottingham University Hospitals NHS Trust,  
Derby Road, Nottingham, NG7 2UH, United Kingdom

<sup>3</sup>Product Design Department, Nottingham Trent University,  
50 Shakespeare Street, Nottingham, NG1 4FQ United Kingdom

[luke.siena@ntu.ac.uk](mailto:luke.siena@ntu.ac.uk), [philip.breedon@ntu.ac.uk](mailto:philip.breedon@ntu.ac.uk), [paul.watts02@ntu.ac.uk](mailto:paul.watts02@ntu.ac.uk), [James.Armstrong2@nuh.nhs.uk](mailto:James.Armstrong2@nuh.nhs.uk), [kipin@doctors.org.uk](mailto:kipin@doctors.org.uk), [Andrew.Norris@nottingham.ac.uk](mailto:Andrew.Norris@nottingham.ac.uk), [phillipa.marsh@ntu.ac.uk](mailto:phillipa.marsh@ntu.ac.uk)

## ABSTRACT

Failure to secure the airway on induction of anaesthesia can result in death and disability. Current equipment does not always provide an optimum solution. Most anaesthetists consider bougies essential equipment for safe anaesthesia. Evaluative systems providing accurate objective data assessing bougie introducer performance data do not exist. The Shape Retention Testing System (SRTS) utilises the Intel® RealSense™ SR300 camera to create an accurate and repeatable testing environment. SRTS collected data will allow anaesthetists to compare device performance that will inform purchase and usage decisions of bougies, ensuring optimum benefit for safe practice.

## 1. INTRODUCTION

Airway management procedures continue to challenge anaesthetists daily, with serious consequences including death or disability, trauma to the airway, cardiac arrest and hypoxemia (Gannon, 1991). Recommendations have been developed by the Difficult Airway Society (DAS) (Frerk et al., 2015) which includes advice on equipment selection.

Current equipment does not always provide optimum solutions. Recent studies and reviews of various devices have demonstrated that the correct selection of equipment can improve management success rates (Cook et al., 2011; Su et al., 2011). Factors including device construction, material selection and ease of operation, influence the success or failure of airway procedures and need to be considered in purchasing and usage decisions. There are a wide variety of devices available on the market, some are sophisticated and expensive such as video laryngoscopes and fiberoptic scopes and others such as the bougie, are relatively simple and inexpensive.

The standard bougie is one of the most common intubation aids used in practice. Bougies (Figure 1) are long, flexible, relatively narrow rods that have some intrinsic “memory”. They can be shaped and directed into the trachea more easily than an endotracheal tube when the laryngeal view is limited. Bougies are commonly used during endotracheal intubation to help guide the insertion of an endotracheal tube into the trachea. They are particularly useful with the management of difficult intubations but must be used with caution to prevent injury.



Figure 1. Selection of Bougies Available Within The UK

There are many versions of bougie introducers available on the market, the most commonly utilised include the Portex® Single Use Bougies (Smiths Medical International Ltd, Kent, UK), SunMed Introducer Bougie (SunMed®, Grand Rapid, USA), InterGuide Tracheal Tube Introducer Bougie (Intersurgical Ltd®, Wokingham, UK), Frova Single Use Introducer (Cook Group Incorporate®, Indiana, USA) and Marshall Single Use Bougie (Marshall Airway Products Ltd, Radstock, UK). However, the original Eschmann Tracheal Tube Introducer “*Gum Elastic Bougie*” (Eschmann® Holdings Ltd, West Sussex, UK) is still considered the gold standard device for use.

Numerous studies have been carried out to assess the use, properties and risks associated with bougie-assisted intubation. Janakiraman et al., (2009) evaluated tracheal tube introducers in simulated difficult intubations,

Annamaneni et al., (2003) compared multiple use and single use bougies in simulated difficult intubations, Marson et al., (2014) considered bougie related airway trauma, Jackson et al., (2009) investigated the force required to remove bougies from tracheal tubes and Hodzovic et al., (2004a) (2004b) evaluated various bougies, the effects of tip pressures and placement considerations. These studies have been instrumental in developing guidelines relating to the management of tracheal intubation in adults.

Many of the above-mentioned studies do not use standardised testing equipment with the required accuracy and in some cases do not use the appropriate equipment required to provide precise results. Attempts were made to look at comparative performance within the studies, however these often failed to assess relevant absolute performance and in some cases, such as assessment of memory, the techniques lacked reproducibility and objectivity. The results collected within these studies are therefore only internally comparable or comparable to studies that use the same testing and equipment protocol or setup.

Equipment selection in current practice is largely based on subjective preference, skillset, operator training and cost. Developing testing systems that analyse comparative device performance based on objective and statistically relevant data would be a major advance potentially reducing airway management related complications and improving success rates. Siena et al., (2017) discusses the importance of difficult airway equipment performance analysis and the concept of a Shape Retention Testing System (SRTS) and a Tip Pressure Testing System (TPTS). The research team at Nottingham Trent University (NTU) and Nottingham University Hospitals Trust (NUH) have now constructed these testing systems and protocols. This paper specifically focusses on the development of the SRTS, its functionality and validation.

### *1.1 System Concept & Patient Benefit*

The SRTS is a standardised, calibrated testing system that can provide quantifiable data on the performance of airway equipment and bougies in particular. In addition to individual and departmental purchasing and use decisions, societies and academics can also use this data to inform guidelines for best practice. Currently no testing system exists for the assessment of the shape retention characteristics and properties of bougies; Siena et al., (2017) presented the concept of testing systems to help standardise equipment assessment. These systems must be adaptable, calibrated to collect relevant, reliable and accurate testing data, and function alongside interchangeable components to standardise system setup regardless of the assessed equipment's diameter and length.

Creating a logic-based programming setup with a protocol of standard movements would aid the manufacture of a standardised testing system with calibrated home and reset functions. The capability to alter testing parameters would also create a repeatable testing system adaptable for variable equipment assessment. The camera system must provide accurate camera/video tracking with fixed frame rates and appropriate field of view (FOV) to track bend angles, tip movements, speed of movement and shape retention. Accurate camera tracking data, captured in combination with interchangeable angle measurement grids, would allow the assessment of data over clinically relevant ranges, both pre and post processing.

Ensuring anaesthetists and Hospital Trusts have objective information will help identify optimum equipment selection for use/purchase, thus ensuring measurable improvements in clinical outcomes and success rates. The system has the potential to be of benefit to patients by:

- Identifying devices with the greatest shape retention, thus ensuring procedures are quicker and more efficient with reduced need for multiple intubation attempts.
- Reduce the risk of airway injury, particularly perforation of the airway due to excessive tip pressures.
- Reduce the risk of damage occurring to the teeth because of the anaesthetist trying to obtain a view due to not being able to manipulate the bougie in situ because of poor malleability.
- Teaching/tutoring methods can be improved as training could be standardised for a set of approved equipment, therefore reducing equipment operator experience factors.

### *1.2 Clinical Need*

There are many bougies available, all designed to perform the same task. Each manufacturer's bougie varies, whether this be rigidity, colour, length, diameter, shape retention capabilities etc. However, to date little evidence supports bougie selection other than personal preference or designated hospital suppliers. Mushambi et al., (2016) recently completed a national survey of tracheal tube introducers and the associated complications suggesting the Gum Elastic Bougie (GEB) is associated with the lowest complication rate; the majority of DAS members prefer the GEB. However, with a price point of approximately £30-60, the GEB is more than twice

the cost of single use bougies. Hodzovic and Latto (2007) suggests hospitals are less inclined to permit the use of the GEB due to the purchase costs. It is, therefore important to identify suitable single use bougies with optimum performance.

The objectification of physician preference is also an important aspect to consider. Although there is some evidence to support reduced tip pressures and reduced risk utilising the GEB (Hodzovic et al., 2004a; 2004b) there is also an argument that physicians likely chose the GEB due to their tactile feedback perceptions of the device. If the physical properties and tactile feedback of the GEB can be replicated into a disposable device, this would be advantageous; however, the argument could still be presented that Hospital Trusts will still not adopt a device without improved clinical performance evidence and financial reductions.

The SRTS & TPTS will provide information to help inform these decisions. Many single use devices available, especially those from suppliers outside of the UK, have not undergone any formal testing in accordance with the UK's Difficult Airway Society's, Airway Device Evaluation Project Team (ADEPT) principles (Pandit et al., 2011). ADEPT formulated advice underlining evidence-based principles, defining minimum evidence requirements to inform purchasing and selection decisions. The ADEPT guidance protocol concludes:

*“All airway-related equipment under consideration must fulfil the minimum criterion that there exists for it at least one source of ‘Level 3b’ trial evidence concerning its use, published in peer-reviewed scientific literature.” (Pandit et al., 2011).*

Intubating quickly and safely is imperative to avoid hypoxic injury; therefore, the speed of intubation is critical. Time taken is affected by the laryngeal view and the number of attempts required. Hodzovic et al (2008) evaluated the clinical effectiveness of the Frova single use tracheal tube introducer and found that first attempt success rates fell when the laryngeal view was poor. Success rates of bougies are affected by device characteristics and construction, including factors such as rigidity, shape retention, flexibility, bend angle and grip position. All these factors should be measured and quantified to identify the optimum bougie for intubation procedures.

### *1.3 Focused Design Approach*

Many designers fail due to a lack of focused approach during the design of everyday products. The design and testing phases are two of the most fundamental aspects to a focused design approach. Following a structured design methodology throughout the design process is extremely important and formulating a product design specification (PDS) and in some cases a component design specification (CDS) is a critical task. During the design of the SRTS, Pugh's Total Design Activity Model (Pugh, 1991) was considered. Predefining a design methodology mapped to the specification promotes an optimum total design activity, ensuring successful design and manufacture activities.

Designing an accurate SRTS will provide the authors with an opportunity to complete a detailed product review of existing bougies and future devices. By doing so, it is possible to conduct a complete market analysis that informs the anaesthesia community of optimum device selection. Ensuring a focused design and testing approach is utilised prior to the design of the testing system is imperative. Hodzovic et al., (2004a; 2004b) and Annamaneni et al., (2003) who evaluate various bougies, fail to consider several important factors within their testing equipment and setup that could influence data accuracy. Planning and utilising a focused design and testing approach ensures that variables that can affect accuracy of results can be both predicted and overcome. To improve validity of collected data in future studies, it is necessary to design new testing systems that accurately record and track various elements simultaneously. Siena et al., (2017), considers the following:

- Accuracy of equipment used to record data; i.e. considering maximum measurement ranges, load-cell capabilities and full-scale deflection accuracy (%FSD).
- Calibration and repeatability of standard testing parameters to allow the evaluation of equipment.
- Regulating/standardising the amount of pressure applied to shape the bougie.
- Repeatability of positional tracking of a bougie (analysis of bougie bend angle and orientation).
- Adaptability of the testing system ensuring accurate and statistically relevant testing data can be collected regardless of device brand.

## **2. SUMMATIVE SRTS PRODUCT DESIGN SPECIFICATION (PDS)**

It is important to consider technology readiness levels (TRLs) during the planning and design of any new medical device or system. TRLs are a systematic metric/measurement system that allows the assessment of the

maturity of technologies or concepts compared to the maturity between different types of technologies (Mankins, 1996). By implementing a design brief and a focused design approach in relation to TRLs, a detailed PDS can be generated.

Measuring technology and device maturity through TRLs, especially in the case of developing the SRTS, will allow new devices to be validated within the laboratory-based environment and progress through the TRL levels; this is most prevalent through TRL levels 4-6. This approach defines the key objectives and activities for the design process, thus ensuring a successful device or system can be produced. A summative PDS for the SRTS has been produced detailing the four key criteria and their detailed design requirements:

### 2.1 Performance

- Repeatable logic-based programming testing system utilising open access software (i.e. Arduino) with a protocol of pre-configured variables (i.e. actuators programmable for set movements). The system must provide a protocol of standard movements, reset protocols and adaptable parameters.
- Requires an accurate camera capable of recording and capturing the required data within the specified field of view (FOV) i.e. 3D Depth Camera. This must be connected to accurate camera/video tracking data acquisition software capable of recording at a fixed frame rate, within an appropriate field of view (FOV) thus allowing tracking of bend angles, tip movements, speed of movement and shape retention.
- Interchangeable angle measurement grids capable of recording different measures over clinically relevant ranges. The grids must be measured based on pixels to ensure calibration can be achieved.
- LED lighting system used to reduce the effects of ambient light to standardise the testing environment.
- Interchangeable components to standardised system setup regardless of the assessed equipment's diameter and length i.e. adaptable bend location points, adjustable grip chuck, adjustable bougie support beam, interchangeable linear actuator location points and motor bed location points.
- A quick speed, retractable bed, used to prevent bougie interference; lock points/brakes will also be required to prevent inaccuracies with data acquisition.
- Live real time object tracking (bougie movement mapping) and post processing assessment software is required to analyse bougie characteristics and suitability.

### 2.2 Installation

- The SRTS is required to be semi-permanent, however collapsible for transportation if required.
- Interchangeable grids are to be inserted into the designated slot; however, they must have a standardised origin and grid spacing to allow confirmation of calibration. Coloured grids may be required based on the variance of bougie colours.
- The lighting system must be installed to standardise the ambient light. This system should also aim to reduce the shadowing recorded on the interchangeable grids.
- The SRTS will require various power sources dependant on the equipment utilised; PC/Laptop (Mains Plug), Intel RealSense 3D Depth Camera (USB Powered), Linear Actuator (12V DC), Geared DC Motor (12V DC) and Brake System (5V DC Solenoid).

### 2.3 Testing

- Regulate and standardise the forces/pressures applied to shape the bougie. (This will vary based on bend location and distance from the bougie tip).
- The SRTS must be capable of conducting repeatable tests for several types of bougies/introducers yet still conform to standardised positional tracking.
- Accurately record and post-process the measurement of the bougie bend angle and orientation.
- The SRTS must be adaptable to allow the real-time data acquisition software to accurately map bougie movement and collect accurate and statistically relevant data regardless of the equipment assessed.
- Post processing software required to track data points and monitor bougie shaping and loss of shape to defining outputs including distance moved, angle variation, starting angle and speed.

### 2.4 Legislation

- The SRTS must be capable of producing quantifiable data that can inform the Difficult Airway Society (DAS) Guidelines and the DAS ADEPT Guidelines (Pandit et al., 2011).
- The system must be capable of contributing information to the DAS guidelines for management of unanticipated difficult intubation 2015, if data collected informs positive changes for best practice.
- The SRTS should conform to the testing requirements set out by the MHRA Medicines and Medical

### 3. SRTS DESIGN & VALIDATION

The SRTS is a vision-based object tracking system that analyses the performance of difficult airway equipment utilising the Intel RealSense SR300 depth-sensing camera and a logic based repeatable testing system with pre-configured variables. The SRTS has been designed to function in three key stages; 1) SRTS control system uses the linear actuator pushers to manipulate the shape of the bougie; 2) The SRTS tracking system utilising object tracking (real time mapping) is activated and begins tracking the linear actuator pusher system (LAPS) then retracts allowing shape retention to be tracked; 3) Post processing data analysis software is utilised to analysedevice performance. An overview of the SRTS testing procedure and functions can be found in Figure 2.

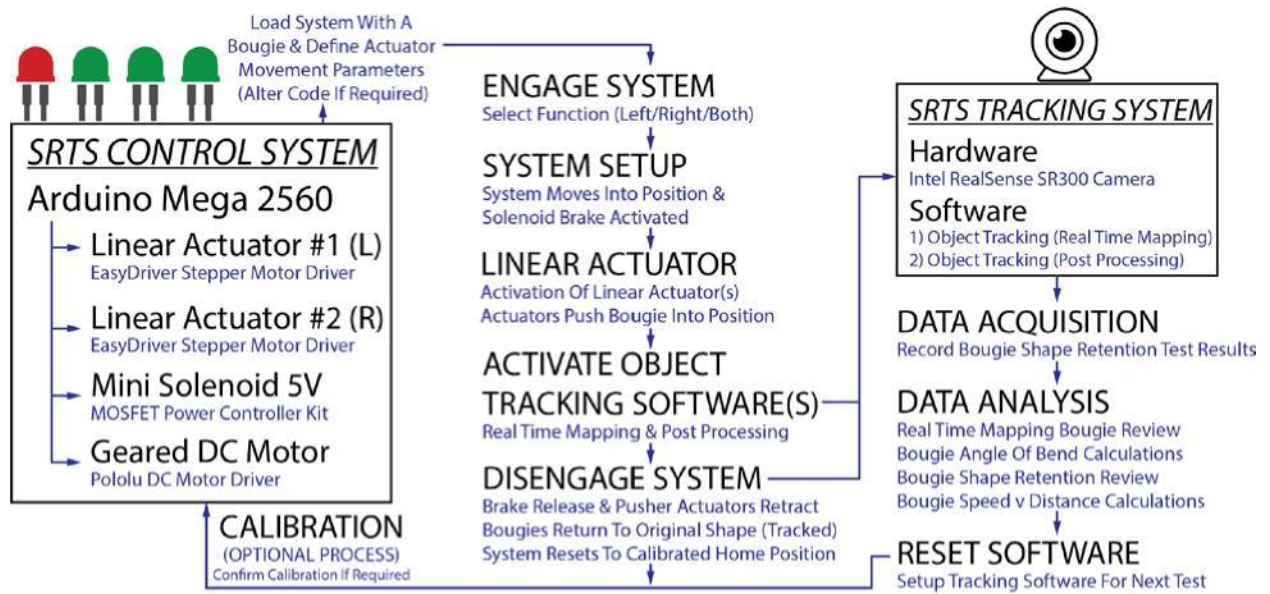

**Figure 2.** Overview of Shape Retention Testing System (SRTS)

#### 3.1 Hardware

The SRTS (Figure 3) has many components that perform individual tasks. The LED lighting system creates a standardised lighting environment. The mechanical chuck grips the bougie and works in combination with the bend location piece, which defines the bougie bend point based on the distance from the bougie tip. The bougie support bar is used to prevent the bougie from falling onto the testing grid. The linear actuator pusher system (LAPS) is controlled by an Arduino Mega 2560 and utilises several motor drivers and power control modules.

Engaging the STRS utilising the power control box, the LAPS controlled by the geared DC motor moves forward until the front switch is pressed. Upon hitting the front switch, the operator then defines and activates the actuator(s) required to shape the bougie. After the completion of the programmed movements, the tracking software(s) are initiated. The disengage button is then pressed and the tracking software records the bougie movements; simultaneously the LAPS is retracting until hitting the back switch which immediately instructs the

LAPS to reset to its calibrated home position. The SRTS utilises an Intel® RealSense™ SR300 depth camera. The SR300 is a short range, coded light 3D imaging system, combining depth sensing with a 1080p RGB camera that can be used for dynamic background segmentation, object tracking, 3D scanning, facial recognition, hand gesture recognition, amongst other applications. The SR300 is utilised in combination with the bougie angle measurement grid, real time mapping object tracking software and object tracking post-processing software to complete the desired tracking functions for the SRTS.

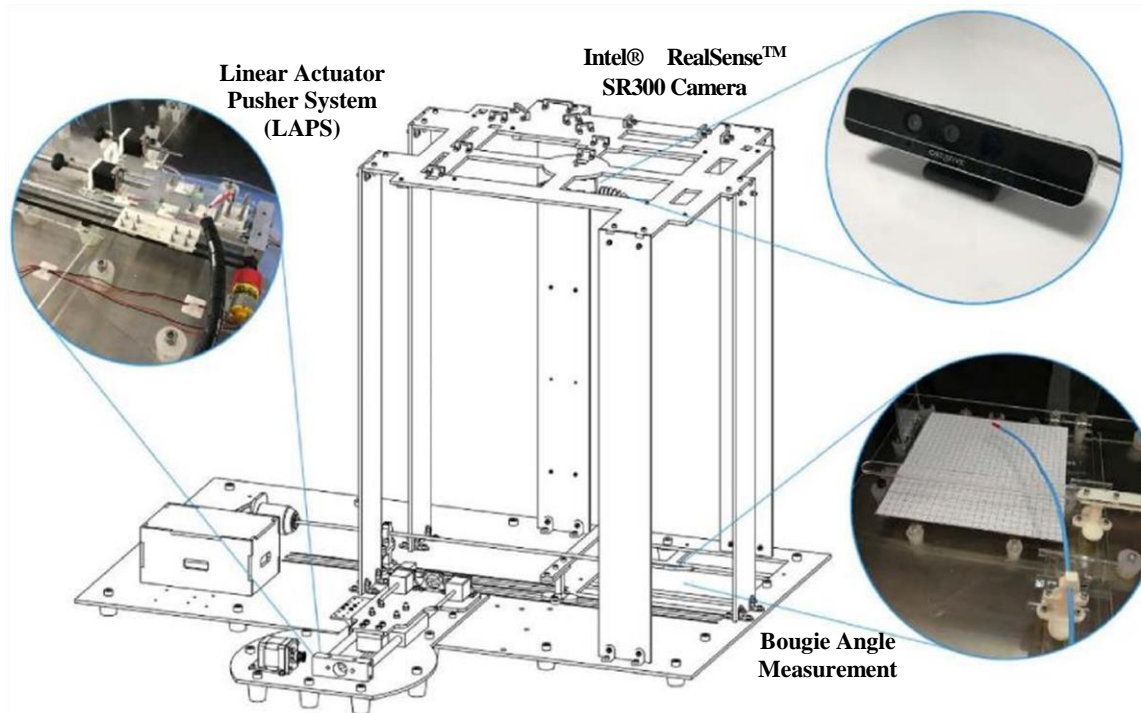

**Figure 3.** Shape Retention Testing System (SRTS) Setup

### 3.2 Software

The SRTS uses two software packages (shown in Figure 4 and 5) to complete an accurate assessment of bougies and their parameters. The Real Time Mapping Software (RTMS) utilises a live feed and object colour tracking to map the bougie tip movements; the Object Tracking Post Processing Software (OTPPS) however tracks the changes of shaping of the bougie whilst tracking the changes in angles, timings and distance. The RTMS identifies coloured objects and tracks their positional movement. When setting up the software, parameters need to be input; these include, selected camera feed, range, object height and width and defining objects colour (Figure 4, Left). Once setup correctly, the coloured object is tracked, and X and Y co-ordinate data is captured and plotted onto a position-tracking map as the object is moved (Figure 4, Right). The OTPPS tracks over a set number of frames and functions by tracking two points on the bougie, the origin/anchor location and the tip of the bougie. Data points are monitored and captured during bougie manipulation and as the bougie attempts to return to its original shape.

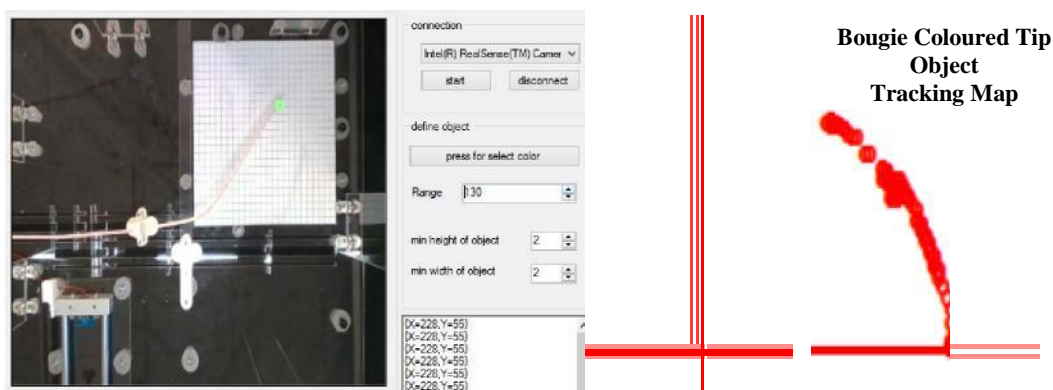

**Figure 4.** Real Time Mapping Software - Tracking Live Feed (Left), Bougie Tip Tracking Map (Right)

The video captured is then post processed and broken down into frame-by-frame images and analyses each image for the location of the anchor marker and the bougie tip marker. The tracked points are converted into X, Y coordinates based on the pixel location at the centre of each of the tracked markers. This is stored into an array with an item in the array for each frame of the video; this data is timestamped with a frame number and the number of frames per second

in the video. Using this data array, we can now query the data to find out where the markers were at any given time in the video feed. Using trigonometry, the angle between the two points from each frame is defined. By subtracting one angle from the other, it is possible to calculate the difference between the two angles and establish how far the bougie has moved in the given time frame. Dividing this value by the time that has elapsed between the frames, the average speed that the bougie moved is calculated.

To avoid miscellaneous data points being tracked in the video stream, the software is setup to use regions of interest (ROI) for each marker. The ROI is the region on the SRTS that the software is instructed to search for markers; it will only seek the markers within the ROI and therefore avoids having the software track other similar items within the video feed that can distort the results. To achieve calibration and the correct scale, we must also calculate the number of pixels in the image per centimetre. This is achieved by placing a 1cm square grid under an observed area, the tracking software then finds the grid within each image and calculates the distance between the lines; the number of pixels residing between the lines provides us the scale in pixels per centimetre. Using this value, it is possible to calculate the distance between any two points within the image frame.

### 3.3 Validation

To validate the OTPPS, an initial bougie shape retention test was conducted. Figure 5 (Left) shows the bougie having been shaped into position by the LAPS and once released the bougies shape retention is tracked; the start and end points of this test can be seen in Figure 5 (Left). The video recorded is then post processed; once complete the OTPPS opens a dialog box with all the tracking data collected. The number of frames analysed (time-scale) can then be altered to calculate the required results.

In Figure 5 (Right), the frames analysed are set between 0 and 1000. Once calculated, a results dialog box appears stating the starting angle position (degrees), the distance moved (mm), angle variation (degrees) and the speed of the bougie movements (mm per second). In the test completed (Figure 5), the bougie was shaped to a starting angle of 121.2°, the bougie then moved 149.27mm from the shaped position to the loss of shape retention position, the angle variation observed was 21.31° and the speed of movement was 3.04 mm/ps.

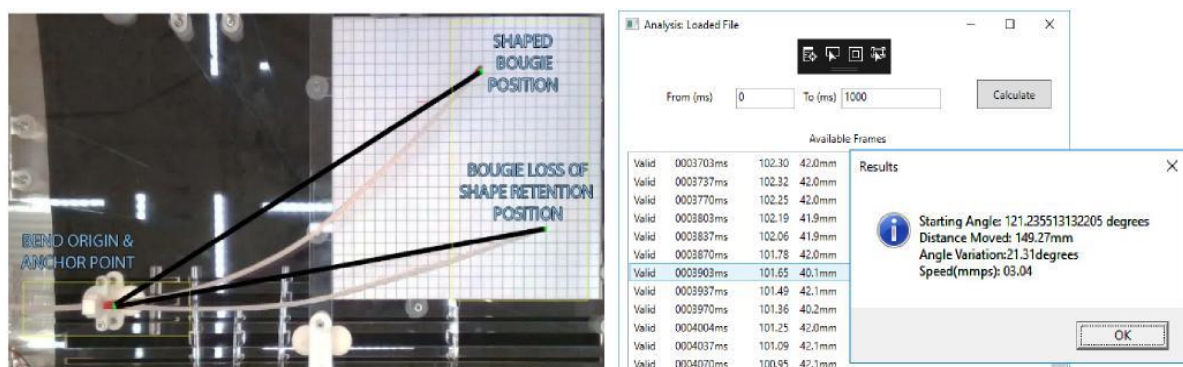

**Figure 5.** Post Processing Software: Shape Retention Bougie Test – Start & End Position (Left), Data Acquisition & Results Screen (Right)

## 4. CONCLUSIONS & FUTURE WORK

Developing the Shape Retention Testing System (SRTS) has generated a standardised, calibrated testing system, capable of providing quantifiable data. This can now help inform anaesthetists of comparative device performance, providing evidence for device selection and purchase and generating evidence for societies and academics to inform their guidelines for best practice. Utilising a focused design approach in combination with a product design specification and technology readiness levels, whilst considering the patient benefit and clinical need, this has enabled the SRTS to be manufactured, tested and validated. The initial testing has also proved that the desired measurables can be acquired utilising the data acquisition software and the post processing software, thus providing data that can be assessed for analytical review.

Based on the initial testing completed, the Object Tracking Post Processing Software (OTPPS) requires a few minor improvements including a calibrated region of interest (ROI) separate from the main grid to create an uninterrupted ROI for ultimate calibration. An adjustable colour input drop down list is required to define the colour of the tracking points that may change based on the variance in colour of different manufacturer's bougies. An adjustable ROI is also required for the anchor tracking point; these may vary based on the required bend

location. Finally, a black out cover (i.e. dark room cover) will also be implemented. The next testing steps for the SRTS is to complete a full assessment of the most popular bougie introducers available on the market.

The Difficult Airway Society (2018) provides a comprehensive list of tracheal tube introducers, exchangers and guides; however not all of this equipment is compared in the studies conducted by Annamaneni et al., (2003), Hodzovic et al., (2004a), (2004b), Jackson et al., (2009), Janakiraman et al., (2009) and Marson et al., (2014). The ultimate objective is that the SRTS will be used to analyse the performance of the extensive bougie introducer range available for purchase to aid and identify the device(s) that provide optimum benefit with safe practice.

**Acknowledgements:** Mr F.L.Siena is a funded PhD student at Nottingham Trent University by a Vice Chancellors PhD Bursary. A Nottingham University Hospitals Charity and NUH Department of Research and Development Pump Priming grant is being used for product development and manufacturing of a Steerable Bougie. The authors would like to acknowledge Mr Frank Worcester's (NTU) contribution to the images produced for this paper.

## 6. REFERENCES

- Annamaneni, R, Hodzovic, I, Wilkes, AR, and Latto, IP, (2003). A comparison of simulated difficult intubation with multiple-use and single-use bougies in a manikin. *Anaesthesia*, 58, 1, pp. 45-49.
- Cook, TM, Woodall, N, Frerk, C, and Fourth National Audit Project. (2011). Major complications of airway management in the UK: results of the Fourth National Audit Project of the Royal College of Anaesthetists and the Difficult Airway Society. Part 1: anaesthesia. *British journal of anaesthesia*, 106, 5, pp. 617-631.
- Cook, TM, and MacDougall-Davis, SR, (2012). Complications and failure of airway management. *British Journal of Anaesthesia*, 109, 1, pp. 68-85.
- Difficult Airway Society, (2018). Tracheal Tube introducers/exchangers/guides, [Das.uk.com](http://Das.uk.com). Retrieved 2 January 2018, from <https://www.das.uk.com/content/tracheal-tube-introducersexchangersguides>
- Frerk, C, Mitchell, VS, McNarry, AF, Mendonca, C, Bhagrath, R, Patel, A, O'Sullivan, E, Woodall, NM, and Ahmad, I, (2015). Difficult Airway Society 2015 guidelines for management of unanticipated difficult intubation in adults. *BJA: British Journal of Anaesthesia*, 115, 6, pp. 827-848.
- Gannon, K, (1991), Mortality associated with anaesthesia. *Anaesthesia*, 46, 11, pp. 962-966.
- Hawthorne, L, Wilson, R., Lyons, G, and Dresner, M, (1996). Failed intubation revisited: 17-yr experience in a teaching maternity unit. *British Journal of Anaesthesia*, 76, 5, pp. 680-684.
- Hodzovic, I, Latto, IP, Wilkes, AR, Hall, JE, and Mapleson, WW, (2004). Evaluation of Frova, single-use intubation introducer, in a manikin. Comparison with Eschmann multiple-use introducer and Portex single-use introducer. *Anaesthesia*, 59, 8, pp. 811-816.
- Hodzovic, I, Wilkes, AR, and Latto, IP (2004). Bougie-assisted difficult airway management in a manikin—the effect of position held on placement and force exerted by the tip. *Anaesthesia*, 59, 1, pp. 38-43.
- Hodzovic, I, and Latto, IP. (2007). Single-use tracheal introducers may not be fit for purpose. *Anaesthesia*, 62, 11, pp. 1189-1190.
- Hodzovic, I, Wilkes, AR., Stacey, M, and Latto, IP. (2008). Evaluation of clinical effectiveness of the Frova single-use tracheal tube introducer. *Anaesthesia*, 63, 2, pp. 189-194.
- Jackson, GNB, Bartlett, R, and Yentis, SM, (2009). Forces required to remove bougies from tracheal tubes. *Anaesthesia*, 64(3), pp. 320-322.
- Janakiraman, C, Hodzovic, I, Reddy, S, Desai, N, Wilkes, AR, and Latto, IP, (2009). Evaluation of tracheal tube introducers in simulated difficult intubation. *Anaesthesia*, 64(3), pp. 309-314.
- Marson, BA, Anderson, E, Wilkes, AR, and Hodzovic, I, (2014). Bougie-related airway trauma: dangers of the hold-up sign. *Anaesthesia*, 69(3), pp. 219-223.
- Mushambi, MC, Ali, P, Dyson, L, and Malik, D. (2016). A national survey of tracheal tube introducers and associated complications. *Anaesthesia*, 71, 7, pp. 853-854.
- Pandit, JJ, Popat, MT, Cook, TM, Wilkes, AR, Groom, P, Cooke, H, Kapila, A, and O'Sullivan, E, (2011). The Difficult Airway Society 'ADEPT' guidance on selecting airway devices: the basis of a strategy for equipment evaluation. *Anaesthesia*, 66, 8, pp. 726-737.
- Pugh, S, (1991), Total design: integrated methods for successful product engineering.
- Siena, F, Breedon, P, Armstrong, J, Marsh, P, and Watts, P, (2017). Performance analysis for difficult airway equipment: Standardising for success. *Journal of Health Design*, 2, 4, pp. 39-41.
- Su, YC, Chen, CC, Lee, YK, Lee, JY, and Lin, KJ, (2011). Comparison of video laryngoscopes with direct laryngoscopy for tracheal intubation: a meta-analysis of randomised trials. *European Journal of Anaesthesiology (EJA)*, 28, 11, pp. 788-795.