



<https://theses.gla.ac.uk/>

Theses Digitisation:

<https://www.gla.ac.uk/myglasgow/research/enlighten/theses/digitisation/>

This is a digitised version of the original print thesis.

Copyright and moral rights for this work are retained by the author

A copy can be downloaded for personal non-commercial research or study,
without prior permission or charge

This work cannot be reproduced or quoted extensively from without first
obtaining permission in writing from the author

The content must not be changed in any way or sold commercially in any
format or medium without the formal permission of the author

When referring to this work, full bibliographic details including the author,
title, awarding institution and date of the thesis must be given

Enlighten: Theses

<https://theses.gla.ac.uk/>
research-enlighten@glasgow.ac.uk

T H E S I S

"TRIPHENYLARSINE-HALOGEN ADDUCTS
AND RELATED COMPOUNDS"

This thesis is presented to the
University of Glasgow in part
fulfilment of the requirements
for the Degree of Doctor of Philosophy

by

Alex. D. Beveridge, B.Sc.(Glas.).

July, 1964.

The University,
Glasgow.

ProQuest Number: 10984176

All rights reserved

INFORMATION TO ALL USERS

The quality of this reproduction is dependent upon the quality of the copy submitted.

In the unlikely event that the author did not send a complete manuscript and there are missing pages, these will be noted. Also, if material had to be removed, a note will indicate the deletion.



ProQuest 10984176

Published by ProQuest LLC (2018). Copyright of the Dissertation is held by the Author.

All rights reserved.

This work is protected against unauthorized copying under Title 17, United States Code
Microform Edition © ProQuest LLC.

ProQuest LLC.
789 East Eisenhower Parkway
P.O. Box 1346
Ann Arbor, MI 48106 – 1346

The author thanks Dr. G.S.Harris for the help and encouragement received during the work leading to the presentation of this thesis. In addition, thanks are due particularly to Dr. D.S.Payne and also to other members of the academic and technical staffs of the Chemistry Department of Glasgow University for numerous useful discussions.

Financial assistance from the Department of Scientific and Industrial Research is gratefully acknowledged.

(i)

NOMENCLATURE.

The nomenclature used throughout the thesis is in general that which is in common use, and in some cases, the familiar rather than the systematic method is used. Tertiary substituted Group V b compounds are named by the accepted use of the suffix "-ine", e.g. Ph_3As is named triphenylarsine. Compounds formed by the addition of a halogen molecule to, say, triphenylarsine - of composition Ph_3AsX_2 - were formerly described as triphenylarsine dihalides, but in this thesis this has been altered slightly. For example, the compound Ph_3AsBr_2 is now named triphenylarsenic dibromide. Similarly, Ph_3SbCl_2 , which was formerly called triphenylstibine dichloride - and even triphenylstibonium dichloride^(a) - is named triphenylantimony dichloride. That is, the suffix "-ine" is retained for trivalent compounds only. This nomenclature has also been used by Kosolapoff.^(b)

These names are intended to give only the stoichiometry of the compound, and when the structure of a particular dihalide is known, and it is desired to describe the compound in terms of the structure, the name is accordingly altered to a more systematic form. Thus the ionic triphenylphosphorus dibromide, $(\text{Ph}_3\text{PBr})^+ \text{Br}^-$, would be called bromotriphenylphosphonium bromide.

The tetrahalides, e.g. Ph_3AsX_4 are named in a manner similar to that used for dihalides. For example, Ph_3AsI_4

(ii)

and $\text{Ph}_3\text{AsI}_2\text{Br}_2$ are called triphenylarsenic tetraiodide and triphenylarsenic diiododibromide respectively. The former of these could also be described as iodotriphenylarsonium triiodide in terms of its true nature ($\text{Ph}_3\text{AsI}^+\text{I}_3^-$).

In the case of simple inorganic compounds and ions, the familiar and not necessarily the most systematic nomenclature is adhered to. Cations of the type R_4M^+ (M = N, P, As, Sb or Bi) are regarded as onium ions, e.g. Ph_3AsBr^+ is called the bromotriphenylarsonium cation, and anions of the type MX_n^{m-} are regarded in the systematic way as substitutedate ions, e.g. $(\text{Ph}_3\text{PBr}_3)^-$ is called the tribromotriphenylphosphate (V) anion.

The trihalide ions could also be described by this system, so that, for example, IBr_2^- and I_3^- would be the dibromiodate (I) and diiodiodate (I) ions respectively. Since, however, this nomenclature is not yet the common usage for trihalide ions, the older description is retained. That is, the above-mentioned ions are called the dibromiodide and triiodide ions respectively.

(a) Rao et al., Nature, 1959, 183, 1475.
Can. J. Chem., 1961, 39, 171.

(b) Kosolapoff, "Organophosphorus Compounds",
Wiley, New York, 1950, p.4.

F O R E W O R D

Whereas many phosphorus-containing organic compounds are essential constituents of living organisms, there are no organic derivatives of arsenic, antimony or bismuth which play a similar role. Indeed such compounds do not even appear to occur in nature, perhaps with the exception of trimethyl arsine, which is produced by the action of living organisms on arsenic containing compounds. (1)

The first synthetic organoarsenic compound was made in 1760 by Cadet (2) who isolated a fuming liquid from the products obtained by heating a mixture of white arsenic and potassium acetate. The liquid, which ignited spontaneously in the air, and which was subsequently known as "Cadet's fuming liquid", was examined by Bunsen from 1837-43. It was a mixture of compounds, one of the main components being an oxygen-containing organoarsenic compound. The oxygen was replaceable by halogens, sulphur and cyanide.

Berzelius likened the compound to the alkali oxides, the alkali metal being replaced by an arsenic-containing organic radical, which he named 'Cacodyl', on account of the disagreeable smell of its compounds, (Gr. kakodes: ill-smelling). Frankland (3), in 1849, recognised the radical as a methyl-arsenic derivative, and the compound 'cacodyl' was shown in 1854, by Cahours and Riche (4) to be $\text{Me}_2\text{As} - \text{As} \text{Me}_2$

that is, the union of two cacodyl radicals. "Cadet's fuming liquid" was shown to consist of 56% "Cacodyl", 40% "Cacodyl" oxide ($\text{Me}_2\text{As}(\text{o})\text{As}(\text{o})\text{Me}_2$) and 4% other products. (5)

In 1850, Lowig and Schweitzer (6) in Zurich, synthesised the first organic derivatives of antimony (triethylstibine) and bismuth (triethylbismuthine). An aromatic arsenic compound was prepared by Béchamp (7) in 1860. Some twelve years after Béchamp's discovery, Michaelis set up three large schools of chemistry at Karlsruhe, Aachen and Restock, to study the organic derivatives of phosphorus, arsenic and antimony. Michaelis' synthetic contribution to this field was most extensive.

Whilst research into these compounds up to the turn of the century was largely academic, thereafter, interest was aroused in their possible value as chemotherapeutic agents. Using the knowledge that arsenic compounds are toxic to animal organisms, Ehrlich investigated the biological effect of over six hundred organoarsenic compounds, and in 1909, found one which cured a parasitic disease. The compound was "salvarsan" (3.3' diamino, 4.4' dihydroxy arsenobenzene) and was found to be particularly effective against "spirochetes" which cause syphilis and "trypanosomes" which are responsible for sleeping sickness and related diseases. Compounds such

as "salvarsan" and its sodium methylene sulphinate derivative, "neosalvarsan", were widely used in chemotherapy for many years, and have only recently been superceded by antibiotics.

During the 1914-18 war, organoarsenic compounds were introduced as chemical warfare agents. Such usage might be described as negative chemotherapy, and the compounds were directed predominantly against the skin, eyes and respiratory organs. Organoarsenic compounds used as war gases were based mainly on arsenic in the trivalent state. For example, phenyl dichloroarsine and phenyl dibromoarsine were employed as lung injurants; diphenyl chloroarsine and diphenyl cyanoarsine as lung irritants, and lewisite or chlorovinyl-dichloroarsine as a vesicant.

As a result of advances in the techniques of modern warfare, the potential of organo-arsenicals as chemical warfare agents has been reduced, and the increasing use of antibiotics in medicine has shifted the value of organo-arsenic compounds from the predominantly medicinal application as germicides to agricultural uses as pesticides.

The considerable research and development in the practical fields indicated, has resulted in the synthesis of an

impressive number and variety of organo-arsenic compounds, and their physical and chemical properties have been extensively studied. In the case of certain groups of compounds, however, there are gaps in our knowledge, particularly concerning their physical nature, about which comparatively little is known, or the available evidence is either contradictory or not strongly based.

A similar but less extensive history may be traced for the organic derivatives of antimony and bismuth.

This thesis is concerned with an investigation into the nature of two such groups of compounds, of empirical formulae $(C_6H_5)_3As Hal_2$ and $(C_6H_5)_3As Hal_4$ (Hal - Halogen), along with their phosphorus and antimony analogues.

I N T R O D U C T I O N .

Compounds of the composition R_3MX_2 (R = alkyl or aryl group; M = P, As, Sb or Bi; X = Cl, Br or I) may conveniently be considered as organosubstituted pentahalides of the element M. The range of such compounds may be formally represented:

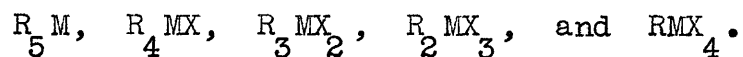

Unlike most organic compounds, whose molecular structure is usually unique and independent of phase and environment, it is often desirable and frequently essential when discussing the structure of an inorganic compound, to specify its physical state. This is particularly true among the pentahalides of the Group Vb elements, and clearly may also be of importance with respect to the organosubstituted pentahalides. Thus, before discussing the structures of the substituted pentahalides, it is clearly advantageous to consider the nature of the pentahalides themselves.

While the elements of the nitrogen group (Group Vb) form compounds which mainly fall into two series based on the M^{III} and M^V states, nitrogen shows substantial differences from the other elements, arising from its ability to fill only the

second quantum shell. Consequently, there is no chemistry of pentavalent nitrogen, and hence no nitrogen pentahalides.

Bismuth forms only a pentafluoride, but there are many examples of simple and mixed pentahalides of phosphorus, arsenic and antimony (8), among which are found an unexpected variety of structural types, which illustrate well the dependence of physical nature on physical state.

For example, phosphorus pentachloride possesses the expected features of a trigonal bipyramid, both in the vapour phase (9), and in solution in non-polar solvents (10) but in the crystalline state, exists as an ionic lattice, $(\text{PCl}_4)^+$ $(\text{PCl}_6)^-$ (11). The ions $(\text{PCl}_4)^+$ and $(\text{PCl}_6)^-$ have also been identified in solution in the polar solvent acetonitrile (10). Antimony pentachloride, on the other hand, is molecular in the vapour phase (9), in the solid (12) and in solution in non-polar solvents. Ionisation to $(\text{SbCl}_4)^+$ and $(\text{SbCl}_6)^-$ occurs, however, in acetonitrile (13).

An even more complex structural variation is exhibited by phosphorus pentabromide, in which phosphorus shows a marked reluctance to take up the co-ordination number five. This pentahalide has an ionic lattice $(\text{PBr}_4)^+$ Br^- , (14) but is dissociated to phosphorus tribromide and bromine in the vapour phase, and the ions $(\text{PBr}_4)^+$ and $(\text{PBr}_6)^-$ are formed

in acetonitrile solutions. (15)

Ionic-covalent isomerism is also found among the pentahalides of phosphorus. For example, the compound of composition PF_3Cl_2 may be isolated as a gas containing trigonal bipyramidal PF_3Cl_2 molecules, (16) or as an ionic solid $(\text{PCl}_4)^+ (\text{PF}_6)^-$, (17) depending on the method of preparation. The compound PF_3Br_2 is similarly dimorphic. (18)

It is thus apparent that the representation of the pentahalides as MX_5 , and the substituted pentahalides as, for example, R_5M and R_4MX , is merely a formal indication of their stoichiometry.

Comparatively few fully substituted pentahalides have been reported. Two apparently pentasubstituted nitrogen compounds have, in fact, been shown to be tetramethyl ammonium salts of the carbanions benzyl and trityl, (19) and the first true example of this type of compound was pentaphenylphosphorus, (20) prepared in 1949 by the reaction of phenyllithium on tetraphenylphosphonium iodide. Similarly, the pentaphenyl derivatives of arsenic, (21) antimony (21) and bismuth (22) have been subsequently prepared. A penta-alkyl, pentamethyl antimony, has also been reported. (23)

The physical and chemical properties of these compounds show that they are not salts of quaternary cations and carbanions, but are covalently bonded. A structural analysis has

been made of pentaphenyl phosphorus, pentaphenyl arsenic and pentaphenyl antimony by Wittig and Wheatley, who found that the phosphorus and arsenic compounds were isomorphous, with a lattice of trigonal bipyramidal molecules. (24) In contrast, however, pentaphenyl antimony was found to possess a molecular lattice of square pyramidal units, unlike other five - co-ordinated antimony compounds. (25)

The pentasubstituted pentahalides do not appear to exhibit a change in structure with changes of phase and environment, and a similar situation is also generally accepted with respect to the quaternary substituted pentahalides.

Quaternary substituted compounds (R_4MX) are known for all of the Group Vb elements. The nitrogen compounds are unambiguously ionic (e.g. $Me_4N^+ I^-$) and although the other elements of the group have d orbitals available for bonding, their physical and chemical properties suggest that they too are ionic, both in the solid state and in solution. The compounds are comparatively high melting crystalline solids, insoluble in non-polar but soluble in polar solvents, in which they give highly conducting solutions, and they readily form double salts with heavy metal halides and the halogens. (e.g. $Me_4As^+ I^-$ forms $Me_4As^+ Hg I_3^-$ and $Me_4As^+ I_3^-$ with $Hg I_2$ and I_2 respectively).

While such evidence is not unambiguous, it is generally accepted, however, that quaternary compounds adopt the ionic form, although it is not improbable that with suitable substituents and a suitable environment, a covalent form would be capable of existence.

The bonding in the primary, secondary and tertiary compounds (RMX_4 , R_2MX_3 , R_3MX_2) is not so clearly established as in the classes of compounds so far discussed. Available evidence concerning the primary and secondary derivatives is sparse and conflicting. From their melting points, and solubility in organic solvents, Rochew, Hurd and Lewis (26) adopt the view that such compounds are covalent, but specifically with respect to the phosphorus compounds, Van Wazer (27) - by analogy with the pentahalides of phosphorus - suggests that the primary and secondary derivatives are ionic, with the organic group(s) in the cation:



Van Wazer does point out, however, that their structures have not been investigated by any physical techniques which would demonstrate such an ionisation. Kosolapoff (28) agrees with Van Wazer's views, and asserts that there is

little doubt that one of the halogen atoms is in the ionic state.

Some experimental results could be cited in support of these views, in that the compound Ph P Br_4 adds bromine to form Ph P Br_6 , (29) and likewise $\text{Ph P Br}_2 \text{Cl}_2$ adds bromine to form $\text{Ph P Br}_4 \text{Cl}_2$. (30) This is analogous to the formation of a double salt between the ionic quaternary salts and the halogens, which is generally assumed to be characteristic of halides of this type. Also, Kuchen and Strolenberg reported in 1962, that diethyl and dipropyl phosphorotribromide add bromine to form the disubstituted phosphorus pentabromides,

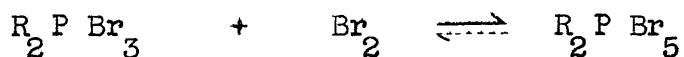

and that both pentabromides, and also disubstituted phosphorus trichlorides give conducting solutions in polar solvents. Conductance values were not given, but the structures $(\text{R}_2 \text{P Cl}_2)^+ (\text{R}_2 \text{P Cl}_4)^-$ and $(\text{R}_2 \text{P Br}_2)^+ \text{Br}_3^-$ were assigned to the trichlorides and pentabromides respectively. (31)

It would therefore seem that primary and secondary substituted phosphorus pentahalides ionise in polar solvents, but their structure in the solid state is not certain. Thus,

the suggestion of Rochow et al., that primary and secondary Group Vb halides are covalent, would seem to be of doubtful validity with respect to phosphorus.

Tertiary compounds (R_3MX_2) are known for each of the Group Vb elements except nitrogen, and again, conflicting reports about their nature have appeared in the literature from time to time.

Trimethylantimony dichloride, - dibromide and - diiodide are the only Group Vb dihalides whose crystal structures have been determined by X-ray methods. (32) Wells, in 1938, found that they had molecular lattices, the units being trigonal bipyramidal molecules in which the methyl groups occupied equatorial and the halogen atoms axial positions. The two Sb - Hal bond lengths are equal in each molecule, but greater than expected for a covalent bond.

Hal	Sb - Hal in Me_3SbHal_2	Sb - Hal sum of Ionic Radii	Sb - Hal in $SbHal_3$
Cl	2.49	2.35	2.37
Br	2.63	2.47	2.52
I	2.88	2.64	2.75

Wells suggests that the structures are best represented as a resonance hybrid.

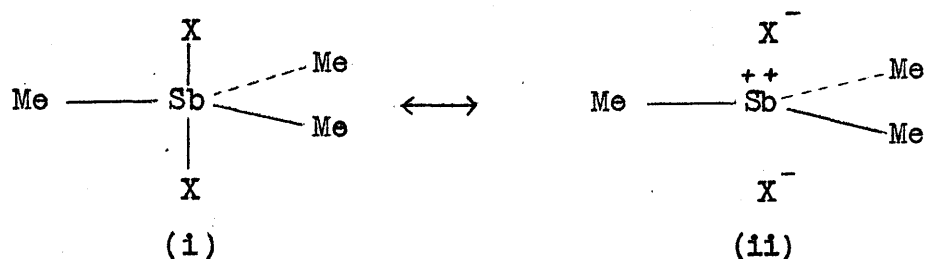

It has been suggested by Mann that the Sb - Hal bond order is about one half. (33)

Conductance studies on trimethyl antimony dihalides have shown them to be only very weak electrolytes in polar solvents like acetonitrile, (34), (35) and both this, and the formation of a hexa-iodide by trimethyl antimony diiodide are explained by structure (ii). (32)

The molecular polarisations of triphenyl antimony dichloride and its bismuth analogue, in benzene, were shown by Jensen to be independent of temperature, and thus the compounds have a zero dipole moment in accordance with the assumption of a trigonal bipyramid. (36) Since the atomic polarisation was very large, however, it was assumed that the bond between the central atom and the halogen atoms was strongly polar, and Jensen suggested the resonance structure:

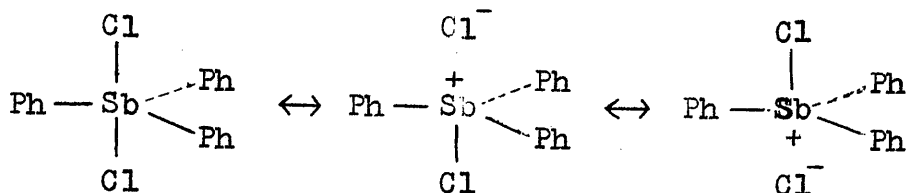

The available evidence has led Rochow et al. to state that "covalency is indicated for the (tertiary) antimony compounds", (37) but Coates is more precise, and regards the tertiary antimony dihalides as appearing to be covalently constituted in the solid, but apparently ionising

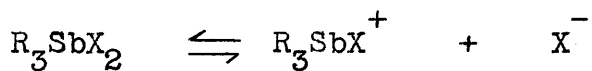

"when dissolved in water and other polar solvents". (38)

There is some confirmation for a halotriphenylstibonium cation, in that complexes of the type $Ph_3SbCl_2 \cdot SbCl_5$ (39) (presumably $Ph_3SbCl^+ SbCl_6^-$ - cf Issleib et al.) (40) have been prepared, but in water, the hydroxyhalides must almost certainly account for high conductance values.

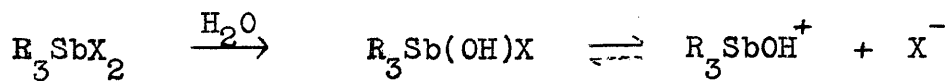

Thus, there are divergent views on the true nature of tertiary antimony dihalides, in both the solid state and in

solution, and it is not clear where contributing resonance structures end, and unique ionic species begin.

The situation with respect to the tertiary phosphorus dihalides in the solid state is more clear cut. Although Mann suggests that tertiary phosphorus dibromides are covalent, and certainly not salts of the type $(R_3P Br)^+ Br^-$, (41) the opposite view has been given by Kosolapoff, who says that one of the halogen atoms is in the ionic state "to all purposes, although the weight of this structure is probably less than it is in the pentahalide". (28) Jensen (36) and Van Wazer (27) also propose an ionic structure $(R_3PX)^+ X^-$, and such a structure has been confirmed for trimethylphosphorus dichloride, - dibromide and-diiodide, by vibrational spectral studies. (42)

Issleib and Seidel (40) have made a comprehensive study of tertiary phosphorus dihalides, and have proved by conductance measurements in nitrobenzene that they behave as electrolytes. The halotriorgano phosphonium cation was identified by double salt formation with antimony and mercury halides, and an ionic structure $(R_3PX)^+ X^-$ was also proposed for the solid state.

The preparation of two tetrahalides of tricyclohexyl

phosphine have also been reported.

The arsenic analogues have also been discussed at some length by various authors. Jensen (36) found that triphenylarsenic dichloride had a zero dipole moment in benzene, and hence deduced that it has a covalent trigonal bipyramidal structure. Mann's (33) views are more or less in accordance with this, and he suggests that there is a high probability of their structures resembling those of the trimethylantimony dihalides, in which the As - Cl bonds have 50% covalent and 50% electrovalent character. He adds, however, that even if the tertiary arsenic dihalides do have a resonance structure of this type:

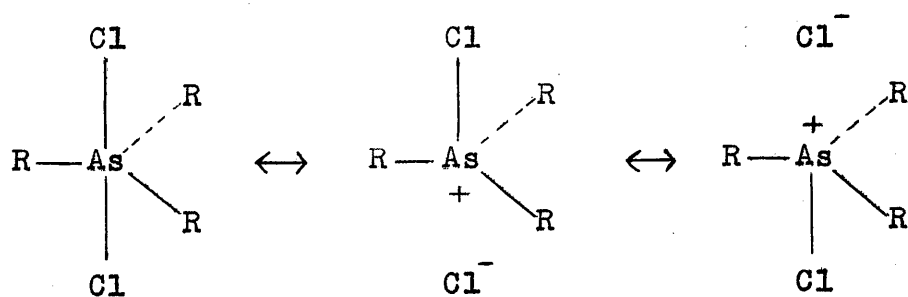

they do apparently revert to an ionic form

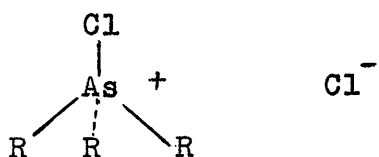

when undergoing certain reactions. This latter conclusion

is based on the fact that one of the chlorine atoms in the compounds R_3AsCl_2 is easily replaced by a hydroxyl group to give a hydroxychloride. Recently, arsenic hydroxyhalides have been shown to be of the form $R_3As(OH)^+ X^-$. (43)

This is a modification of Mann's earlier views expressed in the Tilden lecture of 1945, when following a discussion of the hydrolysis of tertiary arsenic (and phosphorus) dihalides to hydroxyhalides, he stated that the physical and chemical properties of the dihalides showed that they were truly covalent compounds, and not salts. (41)

Rochow et al. (37) have made the general statement that one of the halogens in the tertiary arsenic dihalides appears to be ionic, since "halogens convert the dihalides to tetrahalides; for example, triphenylarsine tetraiodide, probably $Ph_3As I^+ I_3^-$ ". Such evidence for an ionic structure for the tertiary arsenic dihalides, however, would seem to be of a very doubtful nature, since the tetraiodide seems likely to have been formed not by the direct addition of iodine to the anion of the diiodide, but by molecular disproportionation of the diiodide. (44) (45) Hence, tetrahalide formation cannot be cited as proof of an ionic structure $(Ph_3As I)^+ I^-$ for triphenylarsenic diiodide. In

addition, there is no reason why an ionic tetrahalide should not be formed from a covalent dihalide, on the addition of halogen, particularly in cases where the metal - halogen bond has a high degree of ionic character.

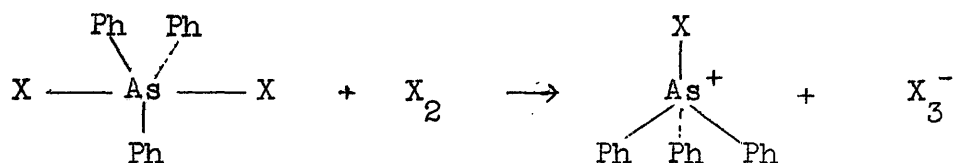

It is therefore clear that the conclusions of some of the earlier workers are often contradictory or weakly based. This is due in part to the use of potentially ambiguous evidence for structural type, such as comparison of melting points, degree of solubility in polar and non-polar solvents and double salt formation. There is also insufficient definition of the physical state of the compounds in these cases where structures are assigned, and both Van Wazer and Coates have recorded the need to examine these compounds by appropriate physical techniques.

Issleib and Seidel, in 1956, made the first detailed study of the solution chemistry of tertiary phosphorus dihalides, and Harris, in 1961, initiated an investigation into the nature of tertiary arsine halogen adducts in acetonitrile.

Molar conductances of triphenylarsenic dichloride, - dibromide, - tetraiodide and - tetrabromide were measured, and while each compound gave solutions which were good electrolytic conductors, the molar conductance values of the tetrahalides were considerably higher than those of the dihalides. The structures $\text{Ph}_3\text{As Hal}^+ \text{Hal}^-$ and $\text{Ph}_3\text{As Hal}^+ \text{Hal}_3^-$ were suggested for the dihalides and tetrahalides respectively, in solution.

The work described in this thesis represents a sequel to Harris' conductance studies, to obtain a clearer picture of the nature of the dihalides and tetrahalides of triphenylarsine in solution. The preparation and study of inter-halogen addition compounds of triphenylarsine have also been undertaken, and similar studies have been extended to the halogen addition compounds of triphenyl phosphine and triphenylstibine. In this way, much of the uncertainty concerning the nature of these compounds in solution has been resolved.

PART 1.

TRIPHENYLARSINE-HALOGEN ADDUCTS.

I N D E X

	<u>page</u>
RESULTS AND DISCUSSION	19 - 70
1. Preparation and Stability of Triphenylarsenic Dihalides.	19
2. Electrolytic Conductance of Triphenylarsenic Dihalides in Acetonitrile.	20
3. Quantitative Electrolyses of Triphenylarsenic Dichloride and Dibromide in Acetonitrile.	24
4. Conductometric Analyses of the Systems Halogen-Triphenylarsine.	32
5. Reaction of Bromine with Triphenylarsine in Acetonitrile.	34
6. Quantitative Electrolysis of Triphenylarsenic Tetrabromide in Acetonitrile.	37
7. Reaction of Iodine with Triphenylarsine in Acetonitrile.	39
8. Reaction of Iodinebromide with Triphenylarsine in Acetonitrile.	43
9. Reaction of Iodinebromide and Iodine with Triphenylarsenic Dibromide in Acetonitrile.	51
10. The nature of Triphenylarsenic Diiododibromide and Triphenylarsenic Iodotribromide in Acetonitrile and in the Solid State.	54
11. Reaction of Iodinebromide with Triphenylarsenic Diiodide in Acetonitrile.	59
12. Reaction of Halogens with Triphenylarsenic Dichloride in Acetonitrile.	66
SUMMARY	71 - 72
EXPERIMENTAL PART.	73 - 91

1. Preparation of Triphenylarsine - Halogen Adducts.	73
(a) Triphenylarsenic Dihalides.	73
(b) Triphenylarsenic Tetrahalides.	75
(c) Tetraphenylarsonium Trihalides.	78
Crystal size.	80
2. Purification of Materials.	81
(a) Triphenylarsine-halogen adducts.	81
(b) Acetonitrile.	81
(c) Carbon Tetrachloride.	82
(d) Diethyl Ether.	82
(e) Bromine.	82
(f) Iodine.	83
(g) Iodine Bromide.	83
(h) Iodine Chloride.	83
(i) Chlorine.	84
(j) Triphenylarsine.	84
3. Preparation of weighed samples of liquids.	84
4. Measurement of Conductance.	85
5. Electrolysis.	86
6. Absorption Spectra.	86
7. Conductometric Titrations.	87
8. Methods of Analysis.	90

RESULTS AND DISCUSSION.

PREPARATION AND STABILITY OF TRIPHENYLARSENIC DIHALIDES.

Dihalides of triphenylarsine may be prepared by direct addition of halogen to triphenylarsine in a suitable solvent. Using carbon tetrachloride and chloroform, Michaelis prepared triphenylarsenic dichloride and dibromide, but was unable to isolate triphenylarsenic diiodide and iodobromide in this way. Instead, he obtained triphenylarsenic tetraiodide and triphenylarsenic diiododibromide ($\text{Ph}_3\text{AsI}_2\text{Br}_2$) respectively. (44)

The diiodide was prepared, however, by Steinkopf and Schwen in 1921, from anhydrous petroleum ether (45) and the preparation of triphenylarsenic iodobromide is reported in this thesis.

The dihalides are solids at room temperature, and on account of their susceptibility to hydrolysis, they must be handled in the absence of moisture: thus, a drybox (Appendix 1) was used, and solvents were of a very high purity and thoroughly dry. Contact of solutions with tap grease and moisture has been minimised by specially designed apparatus, which, before use was baked in an oven for several hours.

ELECTROLYTIC CONDUCTANCE OF TRIPHENYLARSENIC DIHALIDES
IN ACETONITRILE AT 25°C.

Acetonitrile was chosen for conductance measurements since it has very favourable dielectric properties (dielectric constant 36.7 at 25°C.) and its ability to act as a Lewis base frequently results in ion stabilisation.

Solutions of each dihalide were prepared in the conductance cell, and the conductance measured immediately. A slight change in conductance occurred as the solutions warmed to the temperature of the thermostat, but thereafter, a steady value was obtained, and this was used to calculate molar conductance. In each case, the molar conductance decreased with increasing concentration. Values of conductance at 25°C. are shown in Table 1. (on page 21)

While the molar conductance values can only be explained in terms of electrolytic behaviour of the dihalides, it is clear from Table 1 that the compounds fall into two groups - one of high conductance values, and one of low values.

The values of the dichloride and dibromide are considerably lower than is usually found in acetonitrile for strong 1:1 electrolytes of similar concentration, ($\Lambda_m \sim 100 \text{ ohm.}^{-1} \text{ cm.}^2 \text{ mole}^{-1}$) (47), which suggests that the dichloride and

Table 1. Electrolytic conductance of triphenylarsenic dihalides in acetonitrile at 25°C.

Compound	c_m mole litre ⁻¹	$10^4 \kappa$ ohm. ⁻¹ cm. ⁻¹	Δm ohm. ⁻¹ cm. ² mole ⁻¹
Ph ₃ AsCl ₂	0.0016	0.18	11.0
	0.0033	0.24	7.3
	0.0120	0.47	3.9
Ph ₃ AsBr ₂	0.025	4.14	17.0
	0.030	4.70	15.5
	0.036	4.56	12.5
Ph ₃ AsIBr	0.0094	6.06	64.5
	0.020	9.31	46.5
	0.029	12.0	41.5
Ph ₃ AsI ₂	0.0048	3.04	64.0
	0.0058	4.01	59.5
	0.011	6.13	55.5

dibromide should be regarded as weak electrolytes in acetonitrile..

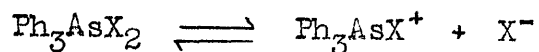

The substantially higher conductance values for triphenylarsenic diiodide and iodobromide indicate that these compounds behave differently in acetonitrile, and subsequent experiments (conductometric analyses) suggested that ionic species of the composition $\text{Ph}_3\text{As}\cdot\text{I}_2$ and $\text{Ph}_3\text{As}\cdot\text{IBr}$ do not exist in acetonitrile. The ultraviolet spectrum of acetonitrile solutions of the diiodide and iodobromide showed the presence of trihalide ions (Table 2), and the molar extinction values calculated from a concentration based on the amount of dihalide dissolved were in keeping with the following behaviour:-

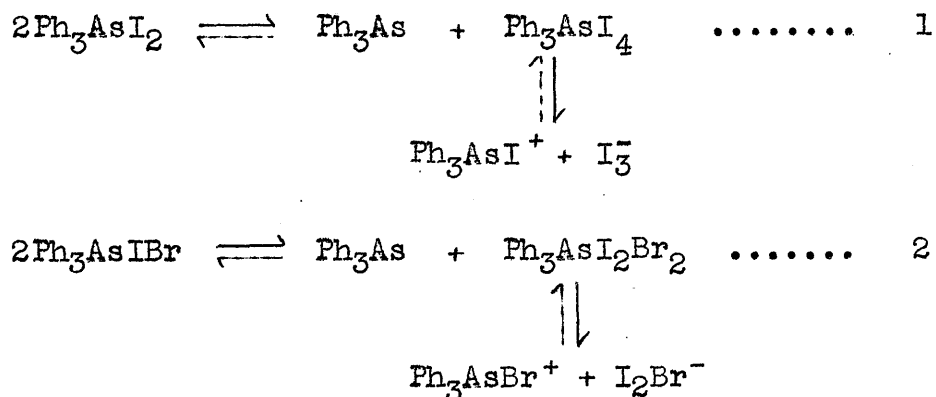

That is, disproportionation of a mole of Ph_3AsX_2 gives half a mole of Ph_3AsX_4 . Compounds of this type (which will be discussed in later chapters) are strong 1:1 electrolytes in acetonitrile, ionising as indicated in 1 and 2.

TABLE 2. Ultraviolet spectra of Ph_3AsI_2 and Ph_3AsIBr in acetonitrile.

Species	λ (m μ)	ϵ	λ (m μ)	ϵ
Ph_3AsI_2	292	28,930	362	15,300
$\text{I}_3^{-\#}$	292	57,680	362	31,090
Ph_3AsIBr	275	22,580	353	4,490
$\text{I}_2\text{Br}^{-\#}$	275	44,550	351	9,670

[#]from Ph_3AsI_4 and $\text{Ph}_3\text{AsI}_2\text{Br}_2$ in acetonitrile.

There is no evidence for this type of reaction in the case of triphenylarsenic dibromide, since no tribromide ion is detectable in the ultraviolet spectrum of its acetonitrile solutions, and is extremely unlikely in the case of the dichloride, since the trichloride ion is a rare entity.

The disproportionation of triphenylarsenic diiodide and iodobromide thus seems to account adequately for their higher molar conductance values.

QUANTITATIVE ELECTROLYSIS OF TRIPHENYLARSENIC DICHLORIDE
AND - DIBROMIDE IN ACETONITRILE.

Consideration of compounds of Group Vb elements analogous to the triphenylarsenic dihalides (10)(15)(40)(42), suggests that there are two probable modes of ionisation differing in the nature of the anion.

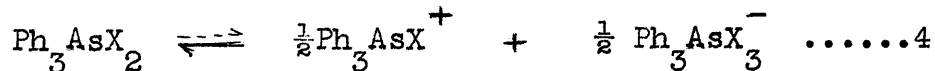
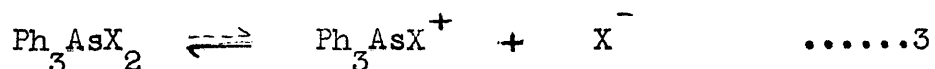

It should be possible to distinguish these by electrolysing a solution of the dihalide in a Hittorf cell, (Appendix 3) and measuring the changes in composition of the solution near the electrodes, after the passage of a known amount of current. These changes can then be compared with changes calculated for the possible values of transport numbers for each ionisation scheme, and the transport number can thus be obtained. In this type of system, in which the passage of current does not occur by a chain transfer process, it is usual for anion and cation to carry current about equally, so that transport numbers in the range 0.35 - 0.65 are expected.

If ΔHal = change in gram atoms of Hal at the electrode;

t^+ = transport number of the cation;

x = quantity of electricity passed (Faradays)

then provided no halogen is lost from the solution during electrolysis, the following relationships hold.

For scheme 3.

at anode: $\Delta \text{Hal} = x(1 - 2t^+)$

at cathode: $\Delta \text{Hal} = x(2t^+ - 1)$

For scheme 4.

at anode: $\Delta \text{Hal} = x(3 - 4t^+)$

at cathode: $\Delta \text{Hal} = x(4t^+ - 3)$

When $x = 1$ Faraday, these expressions give rise to the following values of ΔHal , for values of t^+ between 0 and 1.

Table 3. Ionisation scheme 3.

t^+	0	0.1	0.2	0.3	0.4	0.5	0.6	0.7	0.8	0.9	1.0
$+\Delta \text{Hal}$	1.0	0.8	0.6	0.4	0.2	0	-0.2	-0.4	-0.6	-0.8	-1.0
$-\Delta \text{Hal}$	-1.0	-0.8	-0.6	-0.4	-0.2	0	0.2	0.4	0.6	0.8	1.0

Table 4. Ionisation scheme 4.

	t^+	0	0.1	0.2	0.3	0.4	0.5	0.6	0.7	0.8	0.9	1.0
+	ΔH_{el}	3	2.6	2.2	1.8	1.4	1.0	0.6	0.2	-0.2	-0.6	-1.0
-	ΔH_{el}	-3	-2.6	-2.2	-1.8	-1.4	-1.0	-0.6	-0.2	0.2	0.6	1.0

Table 5 contains the results of a quantitative electrolysis of an acetonitrile solution of triphenylarsenic dichloride.

Table 5. Electrolysis of Ph_3AsCl_2 in acetonitrile.

Electrode	ΔCl g.atoms/F	t^+	
		scheme 3	scheme 4
anode	0.848	0.075	0.54
cathode	0.857	0.075	0.54

The numerical values of the transport number (t^+) show that the nature of the ionic system must be that of scheme 4, being thus analogous to the nature of phosphorus pentachloride (10) and phosphorus pentabromide (15) in acetonitrile. That is, in acetonitrile, triphenylarsenic dichloride ionises:

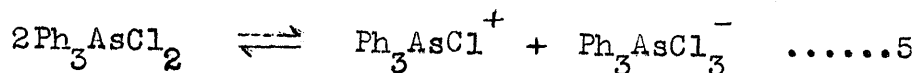

The mode of ionisation thus differs from that proposed by Mann (33), Harris (46) and also Rochow et al. (26) who suggested ionisation scheme 3. The trichlorotriphenylarsenate(V) anion is thus an example of a partially organo-substituted hexahalogenoarsenate(V) anion, which is a rather uncommon species.

During electrolysis, the following processes are likely to be occurring at the electrodes.

At cathode:

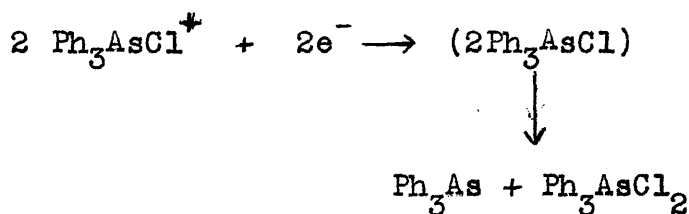

At anode:

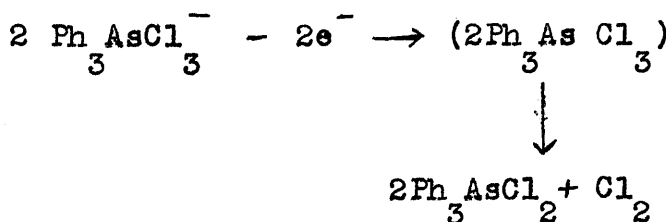

Quantitative electrolyses of solutions of triphenylarsenic dibromide in acetonitrile were similarly carried out,

and a deep yellow colour developed in the hitherto colourless solution at the anode. Values of (t^+) were calculated from Tables 3 and 4, and the results of an experiment are shown in Table 6.

Table 6. Electrolysis of Ph_3AsBr_2 in acetonitrile.

Electrode	ΔBr g.atoms/F	t^+	
		scheme 3	scheme 4
anode	0.142	0.425	0.715
cathode	no change	0.5	0.75

Again on the basis that in such a system the transport numbers will be about 0.5, triphenylarsenic dibromide ionises by scheme 3.

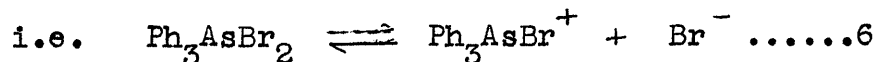

The following electrode processes are suggested.

At cathode:

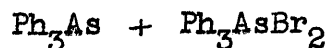
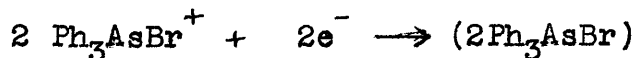

colourless mixture.

At anode:

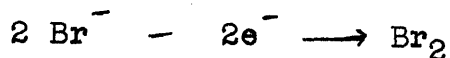

yellow solution.

It is interesting that the modes of ionisation of triphenylarsenic dichloride and dibromide differ in a manner analogous to phosphorus pentachloride and pentabromide in the solid state, (although not in acetonitrile solution).

While caution must be exercised in extending solution data to the solid state, it is concluded that both triphenylarsenic dichloride and dibromide are likely to be covalent solids which ionise partially, only under the influence of the polar solvent. (The dichloride is in fact covalent in benzene). (36) That the triphenyltribromoarsenate(V) anion is not formed, could be attributed to steric factors.

Since the dichloride and dibromide ionise by reactions 5 and 6 respectively, then for steric reasons, the diiodide and iodobromide would also be expected to ionise by scheme 3. The presence of the trihalide ion, however, can only be explained by the presence of molecular as well as ionic dissociation, the free halogen then combining with the halide ion.

The production of the trihalide ion in acetonitrile solutions of triphenylarsenic diiodide will thus follow the course

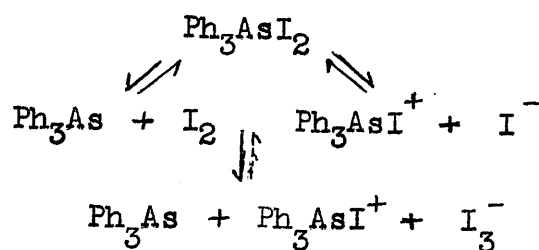

and similarly for triphenylarsenic iodobromide

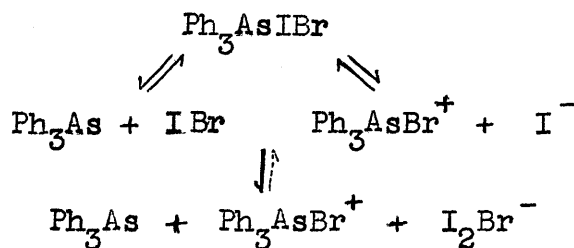

The significance of the formation in the latter case of bromotriphenylarsonium diiodobromide and not iodotriphenylarsonium dibromiodide, is discussed in a later chapter. These disproportionation equilibria are very mobile, since the unchanged dihalides may be recovered from solution by freeze-drying.

Equilibria of this type, involving dual molecular and ionic dissociation, would also give a feasible explanation for Zingaro and Meyers' observation that the dibromo-

iodide ion is formed in solutions of $\text{Ph}_3\text{PS} \cdot \text{IBr}$. (48)

Therefore, the four dihalides of triphenylarsine examined, form conducting solutions in acetonitrile by three distinct means, and the surprising variety in ionic types, found among so few compounds, emphasises the importance of determining experimentally the mode of ionisation of individual compounds of this type. It is possible that the mode of ionisation might also depend on the nature of the organic group.

CONDUCTOMETRIC ANALYSES OF THE SYSTEMS HALOGEN - TRIPHENYL-
ARSINE.

A convenient way of studying the reaction between halogen and triphenyl arsine in an ionising solvent is by conductometric titration. This technique has been widely used in the present work since it offers an alternative approach to the study of the dihalides, and has often yielded useful additional information.

Harris has reported conductometric analyses of the systems bromine - triphenylarsine and iodine - triphenylarsine. (45) In the former system, the conductance-composition graph showed two distinct discontinuities corresponding to the compositions $\text{Ph}_3\text{As}\cdot\text{Br}_2$ and $\text{Ph}_3\text{As}\cdot\text{Br}_4$, but in the latter system the only detectable conducting species was triphenylarsenic tetraiodide. The structure $\text{Ph}_3\text{AsX}^+ \text{X}_3^-$ was suggested for the tetrahalide adducts.

Trihalide ions, if they are produced in acetonitrile, should be identifiable by their absorptions in the ultraviolet region of the spectrum. (49) Therefore, spectrophotometric examination of the solution before, at, and after breaks in the conductance-composition graph should yield more detailed information about the nature of the species in solution. In this way, and from our knowledge

of the nature of the dihalides of triphenylarsine, it has been possible to establish the nature of the reactions which give rise to the two types of titration graphs reported by Harris.

REACTION OF BROMINE WITH TRIPHENYLARSINE IN ACETONITRILE.

The results of a conductometric titration in acetonitrile of bromine against triphenylarsine are recorded in Table 7 and illustrated graphically in fig. 1.

Table 7. Titration of Br₂ vs. Ph₃As in acetonitrile.

Mole ratio Br ₂ : Ph ₃ As	10 ³ K ohm. ⁻¹ cm. ⁻¹	Mole ratio Br ₂ : Ph ₃ As	10 ³ K ohm. ⁻¹ cm. ⁻¹
0.00	0.00	1.46	1.26
0.21	0.21	1.67	1.60
0.42	0.31	1.88	1.94
0.63	0.32	1.98	2.06
0.85	0.43	2.09	2.18
0.94	0.45	2.30	2.28
1.04	0.47	2.50	2.28
1.25	0.88	3.00	2.14

Since triphenylarsine and bromine are effectively non-conductors in acetonitrile (Ph₃As : $\Lambda_m = 0.004$ ohm.⁻¹ cm.² mole⁻¹ at $c_m = 0.055$; Br₂ : $\Lambda_m = 0.22$ ohm.⁻¹ cm.² mole⁻¹ at $c_m = 0.033$) the conductance values obtained during titration show that the interaction of bromine and triphenylarsine is an ion forming process, and

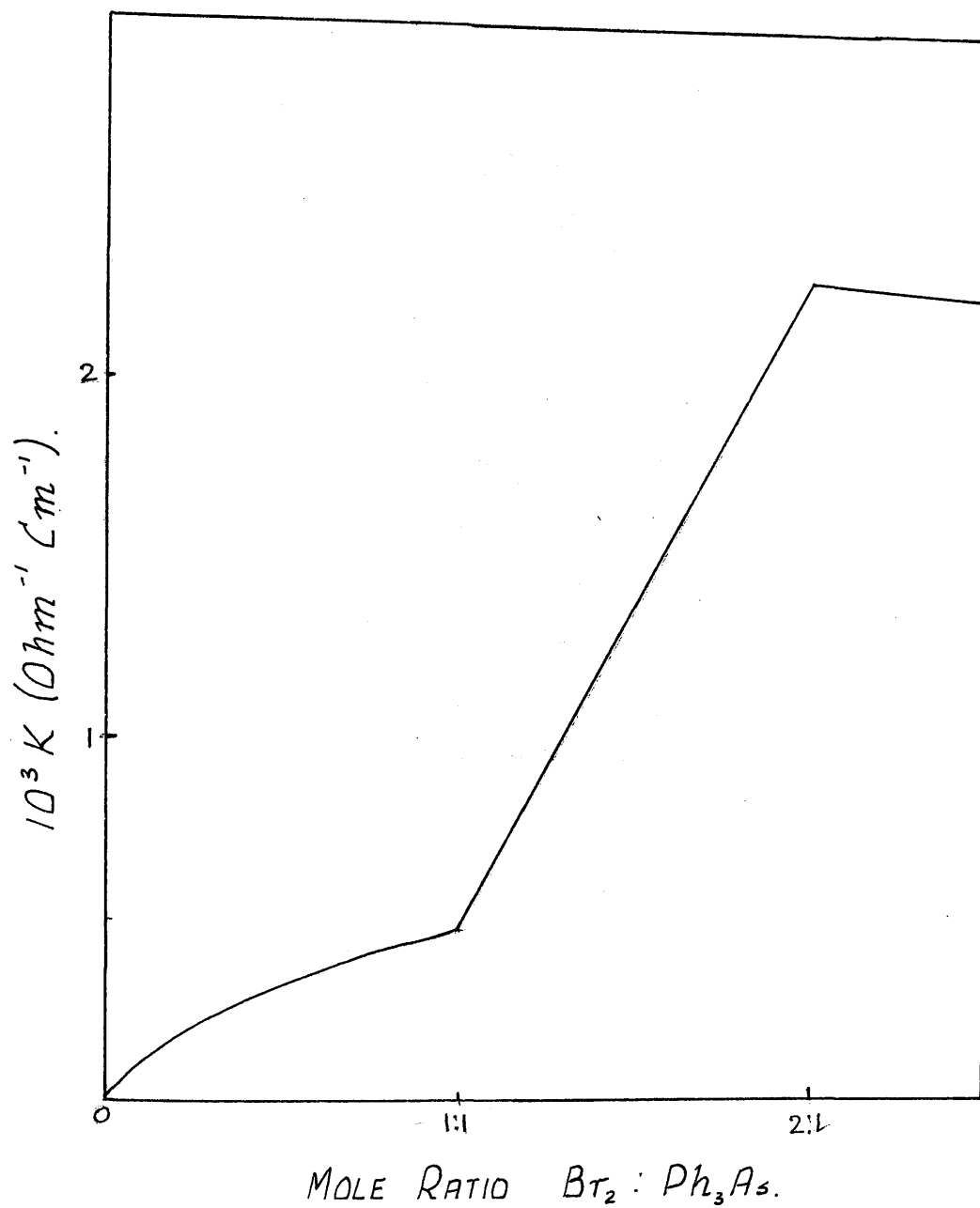

fig. 1. Conductometric titration of Br_2 vs. Ph_3As in acetonitrile.

the discontinuities in conductance at the $\text{Br}_2 : \text{Ph}_3\text{As}$ the discontinuities in conductance at the $\text{Br}_2 : \text{Ph}_3\text{As} = 1:1$ and $2:1$ ratios are good evidence for the existence in solution of ionic complexes of composition $\text{Ph}_3\text{As} \cdot \text{Br}_2$ and $\text{Ph}_3\text{As} \cdot \text{Br}_4$ respectively.

The solution was colourless up to the 1:1 ratio, but thereafter became yellow, and the tribromide ion was observed (U.V. spectrum; $\lambda = 269 \text{ m}\mu$: for Br_3 , $\lambda = 269 \text{ m}\mu$) after the 1:1 ratio only.

Therefore, the reaction of bromine with triphenylarsine takes place in two distinct stages, the first being the formation of triphenylarsenic dibromide, which was, in fact, isolated at the 1:1 ratio. The molar conductance value at this ratio was $\Lambda_m = 15 \text{ ohm}^{-1} \text{ cm}^2 \text{ mole}^{-1}$ at $c_m = 0.03$, which is wholly compatible with the weak electrolytic properties of the dibromide.

Triphenylarsenic tetrabromide was isolated at the 2:1 ratio, at which the molar conductance was $\Lambda_m = 104 \text{ ohm}^{-1} \text{ cm}^2 \text{ mole}^{-1}$ at $c_m = 0.02$. This value is of the order of magnitude of a strong 1:1 electrolyte in acetonitrile (47) and the two stages of the reaction may be written

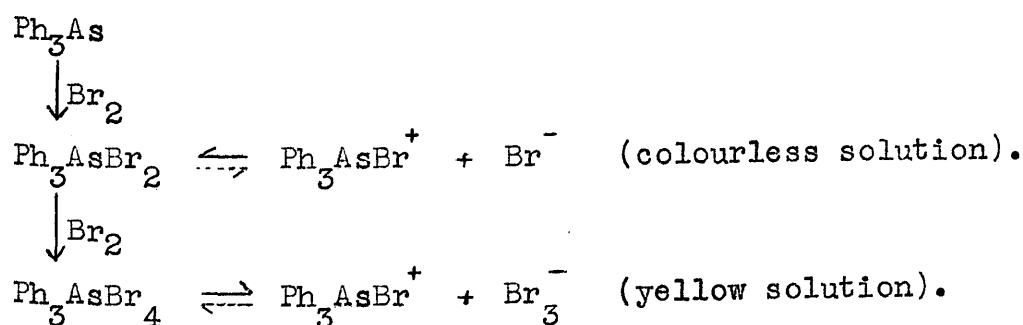

Further addition of bromine (beyond the 2:1 ratio) simply dilutes the conducting solution, causing the slight decrease in specific conductance.

The production of the tribromide ion in this system accords with the findings of Popov and Skelly (50) who have drawn attention to the tendency of halides to form trihalides in acetonitrile, and to the conductance of the resulting solutions.

Harris' view as to the nature of triphenylarsenic tetrabromide is therefore correct, and received additional support from the electrolysis of acetonitrile solutions of the compound.

Electrolysis of Ph_3AsBr_4 in acetonitrile.

The electrolysis was carried out as described in Appendix 3, and during the reaction, the colour of the originally yellow solution became less intense at the cathode, and deep orange at the anode.

For the equation

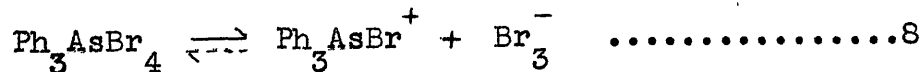

and using the same symbols as before, the relation between t^+ and ΔBr (g.atoms/F) is that given in Table 4 (page 26). Application of experimentally determined values of ΔBr ,

REACTION OF IODINE WITH TRIPHENYLARSINE IN ACETONITRILE.

In contrast to the bromine - triphenylarsine system, a conductometric titration of iodine versus triphenylarsine gave the results shown in Table 9, and illustrated in fig. 2.

Table 9. Titration of I₂ vs. Ph₃As in acetonitrile.

Mole ratio I ₂ : Ph ₃ As	10 ⁴ κ ohm. ⁻¹ cm. ⁻¹	Mole ratio I ₂ : Ph ₃ As	10 ⁴ κ ohm. ⁻¹ cm. ⁻¹
0.00	0.00	1.29	7.54
0.18	1.47	1.48	8.48
0.27	2.04	1.67	9.47
0.37	2.64	1.84	10.5
0.55	3.72	2.02	11.4
0.73	4.43	2.21	11.7
0.93	5.56	2.38	11.8
1.03	6.08	2.57	11.9
1.23	7.02	2.75	11.9

The originally colourless solution became red after the first addition of iodine, and the conductance rose steadily up to the mole ratio I₂ : Ph₃As = 2:1 corresponding to the formation in solution of an ionic complex

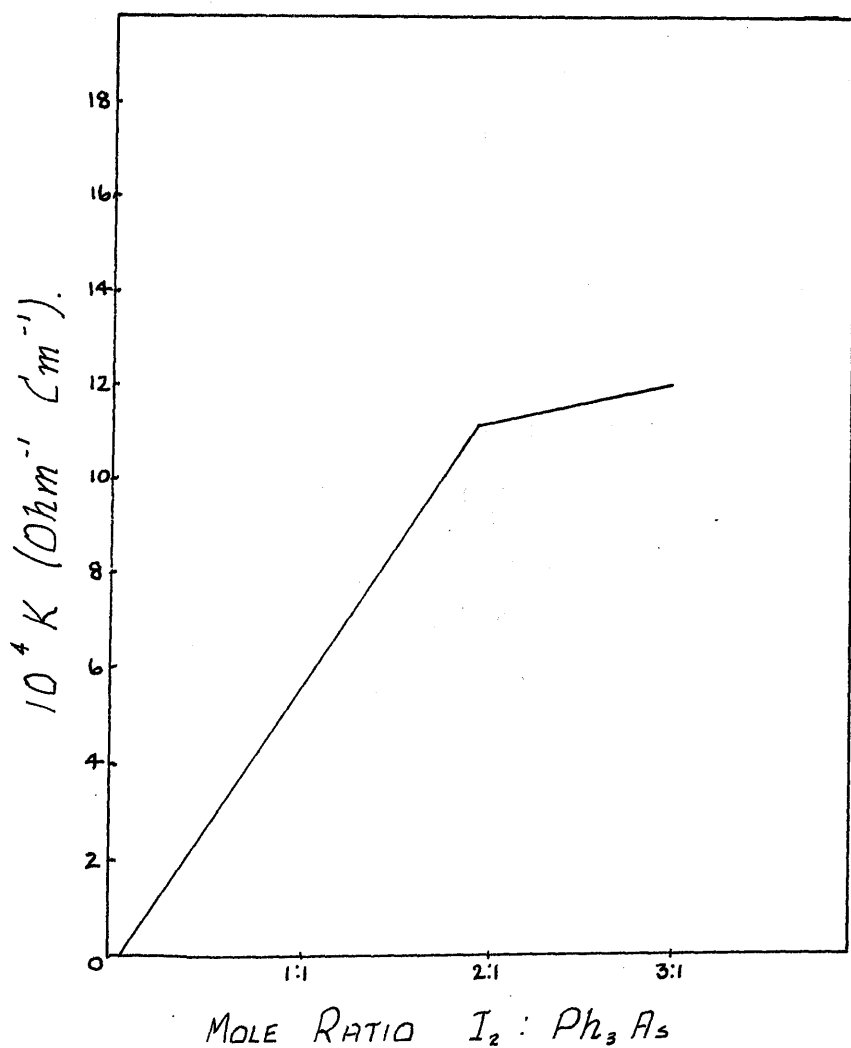
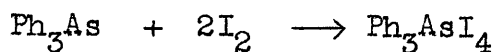

fig.2. Titration of I_2 against Ph_3As in acetonitrile.

of composition $\text{Ph}_3\text{As}\cdot\text{I}_4$. There was no change in slope at $\text{I}_2 : \text{Ph}_3\text{As} = 1:1$ which would have indicated the existence in solution of the diiodide.

The ultraviolet spectrum of the solution from just beyond the zero mole ratio, showed that the triiodide ion was formed immediately in the titration ($\lambda = 291$ and $360 \text{ m}\mu$; for I_3^- , $\lambda = 291$ and $360 \text{ m}\mu$), suggesting that the tetraiodide, unlike the tetrabromide, is formed straight away,



without the formation of the intermediate diiodide as a stable entity in solution. This accords with the fact that the ultraviolet spectrum of the solution obtained when triphenylarsenic diiodide is dissolved in acetonitrile, has shown that the equilibrium

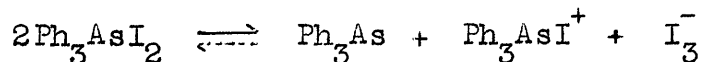

lay well to the right hand side (Table 2, page 23).

Triphenylarsenic tetraiodide crystallised as purple needles m.p. $138-9^\circ$, from an acetonitrile solution containing iodine and triphenylarsine in a 2:1 ratio. Its preparation by this method has already been reported by Michaelis,(44) and Harris. (46) Zingaro and Meyers (48) obtained the compound from the reaction of triphenylarsinesulphide, and iodine

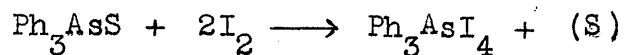

Triphenylarsenic tetraiodide behaves as a strong 1:1 electrolyte in acetonitrile ($\Lambda_m = 100 \text{ ohm}^{-1} \text{ cm}^2 \text{ mole}^{-1}$ at $c_m = 0.011$), and the U.V spectrum of its acetonitrile solutions confirm the ionisation

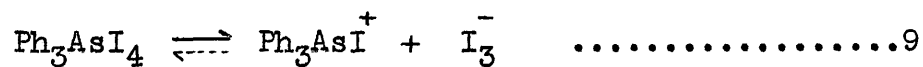

(Table 2, page 23).

REACTION OF IODINE BROMIDE WITH TRIPHENYLARSINE IN ACETONITRILE.

Michaelis (44) has reported that the reaction of iodinebromide and triphenylarsine in chloroform, yielded only triphenylarsenic diiododibromide ($\text{Ph}_3\text{AsI}_2\text{Br}_2$). However, he gave no analytical figures in support of the postulated composition, and the only subsequent attempt to prepare this compound was unsuccessful. (51)

The question of the existence of this tetrahalide is not, however, only of synthetic interest. By analogy with the tetraiodide and tetrabromide, it would be expected to behave as a halotriphenylarsonium trihalide in acetonitrile, for which there are two possible modes of ionisation,

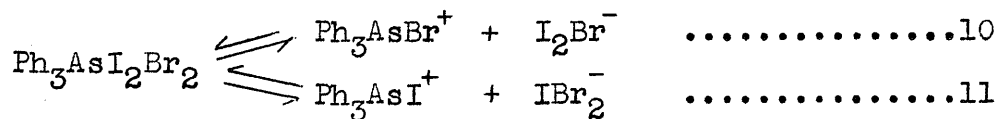

and it would clearly be of interest to relate the mode of ionisation with the stabilities of the trihalide ions. These latter ions, constitute the largest class of the ionic polyhalide species. (52) Both unipositive and uninegative ions containing three halogen atoms are known, although the latter are much more common, and are formed by all of the

halogens, including astatine. (53) Structural analyses of mixed trihalides have been few (52), but it appears that the halogen of highest atomic weight occupies the central position of a linear arrangement.

Trihalides are not stable with respect to dissociation into halogen and halide, and the tendency for this to occur has been determined by dissociation pressure experiments on the solid compounds (54), and also by measuring the degree of dissociation in aqueous (55) and non-aqueous (56) solvents. These have led to the general conclusion that the most symmetrical trihalides are also the least dissociated. Thus, the dibromiodide ion $(\text{Br-I-Br})^-$ is more stable than the diiodobromide ion $(\text{I-I-Br})^-$; the dichlorobromide ion $(\text{Cl-Br-Cl})^-$ is more stable than the dibromochloride ion $(\text{Br-Br-Cl})^-$ et cetera. Also, the iodine-centred dibromiodide ion is more stable than the tribromide ion. Further, the stability of a trihalide is greater when the cation is large and symmetrical. Hence, since the cations Ph_3AsBr^+ and Ph_3AsI^+ are of similar size and symmetry, it would be expected that triphenylarsenic diiodobromide, if it existed, would ionise by equation 11.

Conductometric titration of iodinebromide against triphenylarsine in acetonitrile.

To investigate the possible existence of triphenylarsenic diiododibromide in acetonitrile, iodinebromide was titrated conductometrically against triphenylarsine. The results are recorded in Table 11 and illustrated in fig. 3.

Table 11. Titration of IBr vs. Ph₃As in acetonitrile.

Mole ratio IBr : Ph ₃ As	10 ³ K ohm. ⁻¹ cm. ⁻¹	Mole ratio IBr : Ph ₃ As	10 ³ K ohm. ⁻¹ cm. ⁻¹
0.00	0.00	1.48	7.58
0.21	1.08	1.68	8.90
0.42	2.02	1.89	10.4
0.63	3.05	2.00	11.33
0.84	3.96	2.10	11.73
1.05	4.96	2.31	11.78
1.27	6.12	2.53	11.75

The shape of the graph was similar to that of the iodine-triphenylarsine system. That is, there was no break at the IBr: Ph₃As = 1:1 ratio, thus indicating that the dihalide triphenylarsenic iodobromide does not exist as a stable entity in this solvent. The break at IBr:Ph₃As =

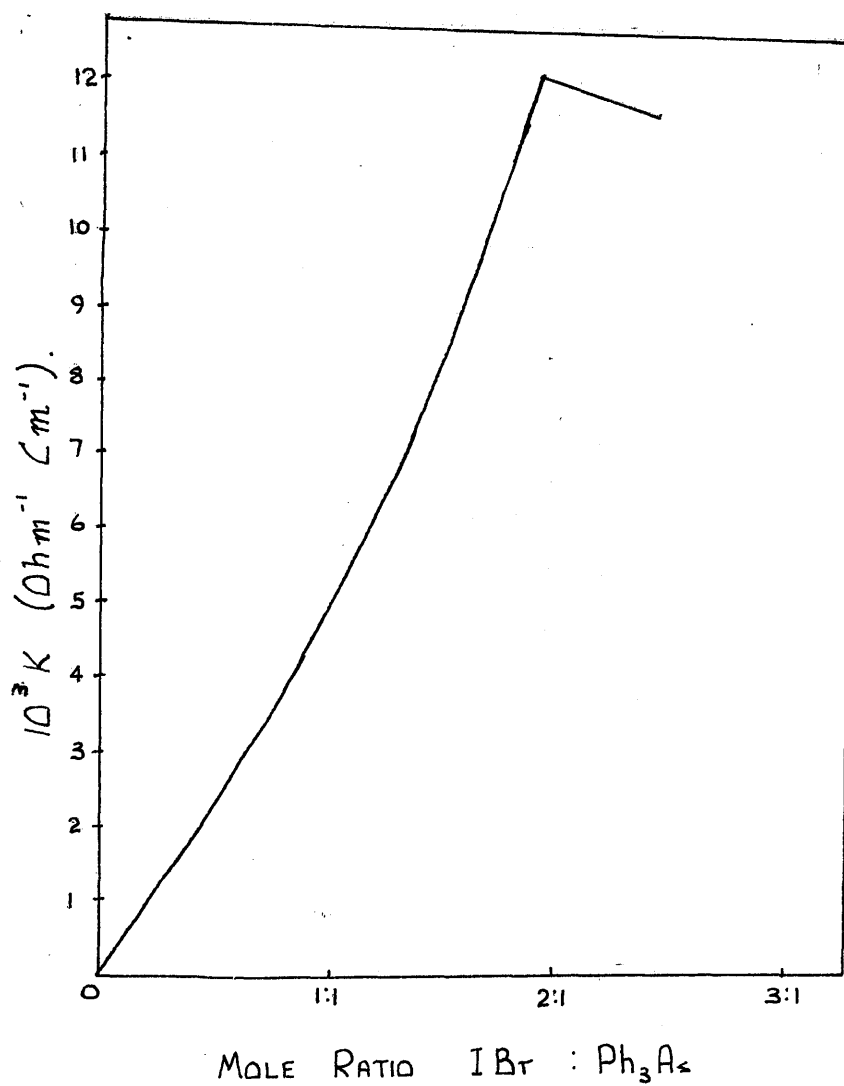

Note very slight upward curve.

fig.3. Titration of IBr against Ph₃As in acetonitrile.

2:1, however, is good evidence for the formation in solution of an ionic complex of composition $\text{Ph}_3\text{As} \cdot (\text{IBr})_2$.

The solution became red as soon as iodine bromide was added, and the ultraviolet spectrum showed that the diiododibromide ion was formed immediately in the titration ($\lambda = 275$ and $351 \text{ m}\mu$; for I_2Br , $\lambda = 280$ and $351 \text{ m}\mu$ (49)), and up to the conductance break at the 2:1 ratio. Thereafter, the peak at $351 \text{ m}\mu$ gradually disappeared, and the one at $275 \text{ m}\mu$ appeared to move to successively lower wavelengths until it remained steady at $257 \text{ m}\mu$. This latter peak is characteristic of the dibromiodide ion, and its appearance coincided with the addition of three moles of iodinebromide to triphenylarsine.

In parallel with this transformation of trihalide ion, the colour of the solution changed from red at the 2:1 ratio, to orange at the 3:1 ratio.

Therefore, triphenylarsenic diiododibromide (like the tetraiodide) is formed immediately in the reaction, and the overall reaction up to the 2:1 ratio is

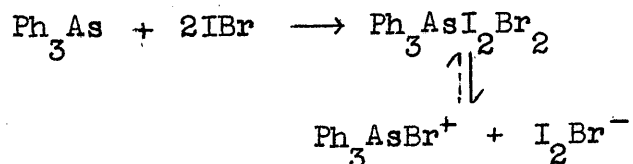

Thus, triphenylarsenic diiododibromide forms the less stable diiodobromide ion, and the ultraviolet studies indicate that beyond the 2:1 ratio, a second reaction occurs in which iodine bromide converts this to the dibromoiodide ion

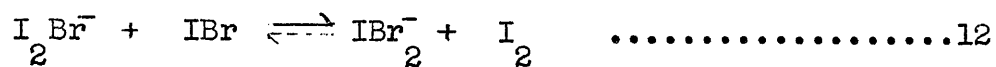

That is, the less stable trihalide ion is converted to the more stable one by a halogen containing a more electronegative halogen atom. (57)

The occurrence of this reaction was confirmed by following the changes in the ultraviolet spectrum of an acetonitrile solution of tetramethylammonium diiodobromide, during the addition of an equimolar solution of iodinebromide. The results exactly paralleled those given on page 47. It should be noted, however, that although reaction 12 can be explained in terms of trihalide ion stabilities, the relative stabilities of the halogen molecules will also affect the course of the reaction, and in the present situation, these must be less important.

The observed intermediate peaks in the ultraviolet spectra between the 2:1 and 3:1 ratios, arise from overlap of the broad and not widely separated maxima at 275 m μ

(I_2Br^-) and 257 m μ (IBr_2^-) giving an apparent maximum which reflects the relative concentrations of the two anions.

If this last stage in the reaction between iodine-bromide and triphenylarsine is as postulated, then a new tetrahalide of triphenylarsine - bromotriphenylarsonium dibromiodide - is indicated in acetonitrile. It is not surprising that this compound was not detected by a break in the conductance-composition graph, since it is formed by changing one trihalide ion into another of closely similar type, and a significant change in conductance would not be expected.

Three solid compounds have, in fact, been isolated from concentrated acetonitrile solutions of iodinebromide and triphenylarsine in the ratios 1:1, 2:1, and 3:1.

Triphenylarsenic iodobromide crystallised in a yield of 95% on mixing saturated equimolar solutions, thus illustrating well, the mobility of the equilibrium.

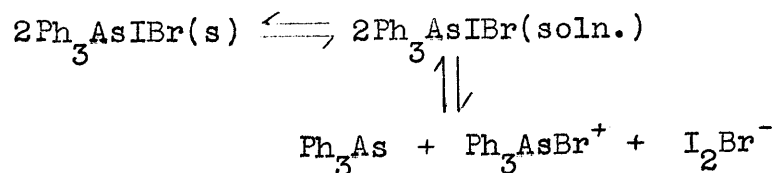

which is pulled to the left hand side when the solution is sufficiently concentrated to induce precipitation.

Therefore, triphenylarsenic iodobromide, which Michaelis had failed to prepare, has been successfully isolated.

Triphenylarsenic diiododibromide was readily obtained as a red crystalline solid, m.p. 104°C ., by adding ether to the solution at the 2:1 ratio. Both the melting point and colour of this compound are significant, since the compound described by Michaelis as having the composition $\text{Ph}_3\text{AsI}_2\text{Br}_2$ was an orange-red solid, m.p. $120-1^{\circ}\text{C}$.

This disparity was resolved when triphenylarsenic iodotribromide, isolated by ether precipitation at the 3:1 ratio, was found to be an orange solid, m.p. $120-1^{\circ}\text{C}$. Therefore, Michaelis' claim to have isolated triphenylarsenic diiododibromide from the reaction between iodinebromide and triphenylarsine must be viewed doubtfully, and it appears that the compound which he isolated was, in fact, triphenylarsenic iodotribromide.

REACTION OF IODINE BROMIDE AND IODINE WITH TRIPHENYLARSENIC
DIBROMIDE IN ACETONITRILE.

An alternative approach to triphenylarsenic diiodo-
dibromide and-iodotribromide is the reaction of iodine and
iodinebromide with triphenylarsenic dibromide in aceto-
nitrile.

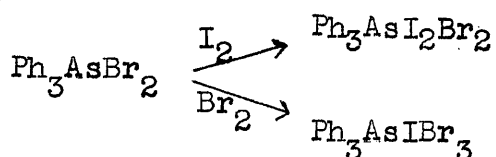

The graphs obtained in conductometric analyses of
these systems were similar, and the results for iodine
bromide against triphenylarsenic dibromide, are recorded
in Table 12, and illustrated in fig. 4.

Table 12. Titration of IBr vs. Ph₃AsBr₂ in acetonitrile.

Mole ratio IBr:Ph ₃ AsBr ₂	10 ³ K ohm. ⁻¹ cm. ⁻¹	Mole ratio IBr:Ph ₃ AsBr ₂	10 ³ K ohm. ⁻¹ cm. ⁻¹
0.00	0.73	0.94	3.54
0.15	1.22	1.09	3.99
0.31	1.75	1.25	3.90
0.47	2.25	1.41	3.87
0.63	2.75	1.57	3.74
0.78	3.08	1.73	3.71

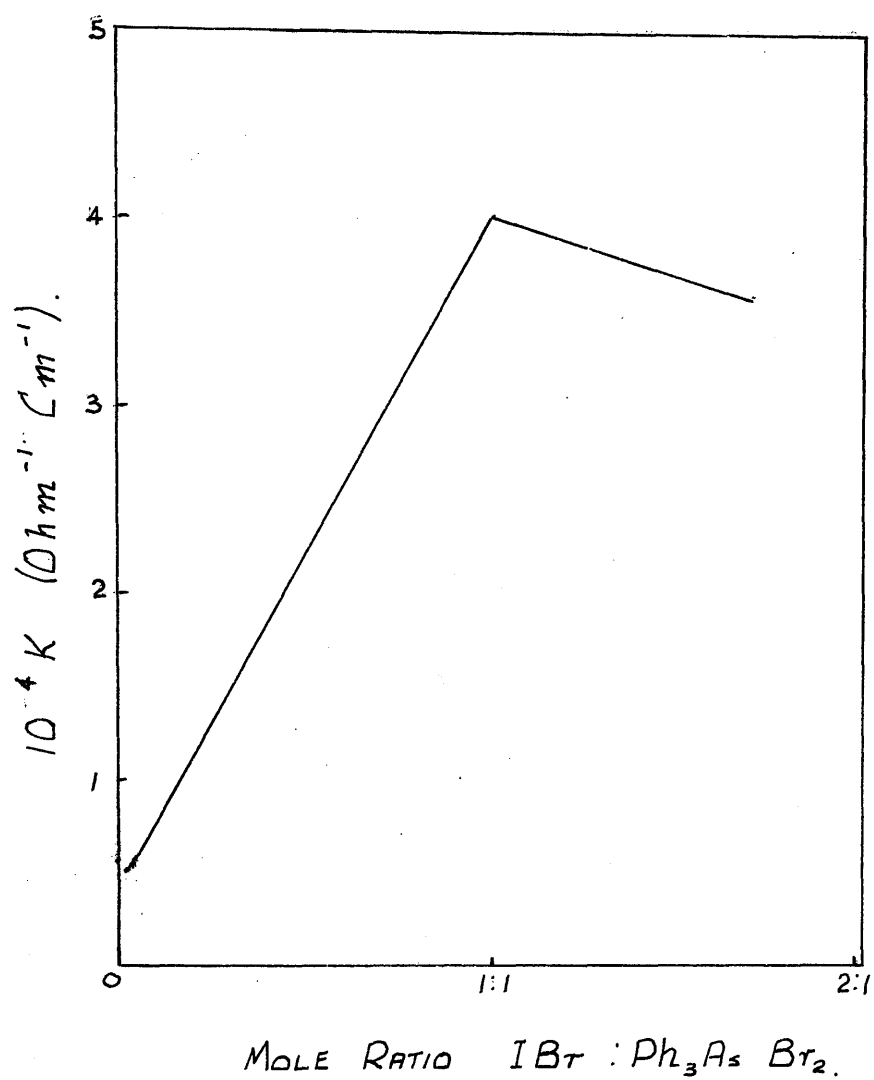
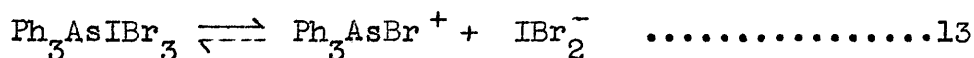
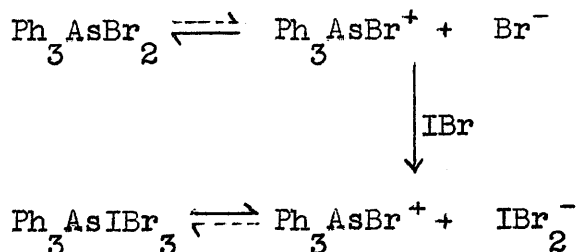

fig.4. Conductometric Titration of IBr against Ph_3AsBr_2
in acetonitrile.

The formation of triphenylarsenic iodotribromide in solution, is shown by the break at $\text{I Br} : \text{Ph}_3\text{AsBr}_2 = 1:1$, and the solid tetrahalide was isolated from concentrated solutions in this ratio. Since the dibromiodide ion was present in solution beyond the zero mole ratio, (U.V. spectrum : $\lambda = 257 \text{ m}\mu$), and the molar conductance at the 1:1 ratio was $\Lambda = 97 \text{ ohm}^{-1} \text{ cm}^2 \text{ mole}^{-1}$ at $c_m = 0.04 \text{ mole litre}^{-1}$, it is concluded that triphenylarsenic iodotribromide is a strong electrolyte in acetonitrile, ionising



and the reactions in solution leading to its formation must be:



An analogous result for the titration of iodine against triphenylarsenic dibromide, leads to triphenylarsenic diiododibromide.

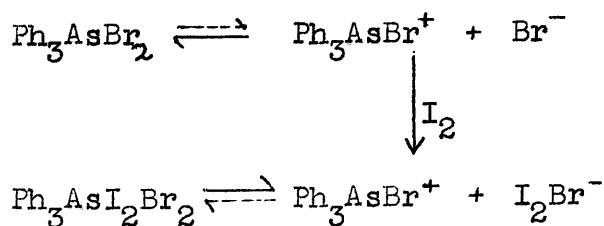

THE NATURE OF TRIPHENYLARSENIC DIIODODIBROMIDE AND TRIPHENYLARSENIC IODOTRIBROMIDE IN ACETONITRILE AND IN THE SOLID STATE.

Both triphenylarsenic diiododibromide and iodotribromide were readily soluble in acetonitrile, in which they gave conducting solutions. Following a slight change while the solutions attained the temperature of the thermostat, the conductance values were stable over twenty four hours. Values of conductance are given in Table 13.

Table 13. Electrolytic conductance of $\text{Ph}_3\text{AsI}_2\text{Br}_2$ and $\text{Ph}_3\text{AsIBr}_3$ in acetonitrile at 25°C.

Compound	c_m mole litre ⁻¹	$10^3 \kappa$ ohm ⁻¹ cm ⁻¹	Λ_m ohm ⁻¹ cm ² mole ⁻¹
$\text{Ph}_3\text{AsI}_2\text{Br}_2$	0.0042	0.54	129.0
	0.0091	1.10	121.0
	0.016	1.80	112.0
$\text{Ph}_3\text{AsIBr}_3$	0.0028	0.35	125.0
	0.0098	1.08	110.0
	0.016	1.56	97.0

The molar conductance increased with increasing dilution, and bore a linear relationship to the square root of the concentration over the range studied (0.002-0.03 M) and

their magnitude indicate that these tetrahalides behave as strong 1:1 electrolytes in acetonitrile.

The U.V. spectra recorded during the conductometric titrations, have shown that these compounds must ionise

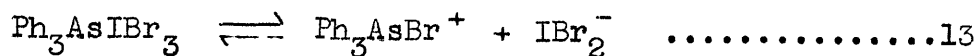
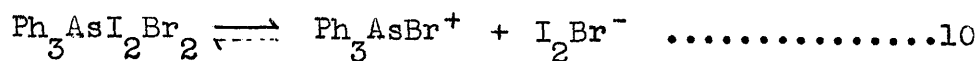

respectively in acetonitrile, and this has been confirmed from the ultraviolet spectra of solutions of the solid compounds dissolved in the same solvent. (Table 14).

Table 14. U.V. spectra of $\text{Ph}_3\text{AsI}_2\text{Br}_2$ and $\text{Ph}_3\text{AsIBr}_3$ in acetonitrile.

Compound.	λ (m μ)	ϵ	λ (m μ)	ϵ
$\text{Ph}_3\text{AsI}_2\text{Br}_2$	275	44,550	351	9,670
$\text{Me}_4\text{N} \cdot \text{I}_2\text{Br}^-$ (49)	280	40,600	351	11,600
$\text{Ph}_3\text{AsIBr}_3$	257	53,130	-	-
$\text{Me}_4\text{N} \cdot \text{IBr}_2^-$ (49)	256	54,000	370	606

That triphenylarsenic diiododibromide ionises by equation 10, is not what was predicted, since if the stability of the trihalide ion controlled the course of

ionisation, the possible alternative

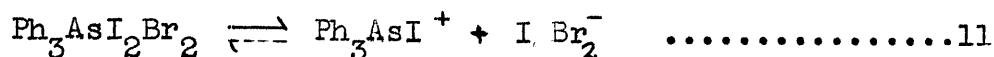

would have been expected. Therefore, the factor controlling the mode of ionisation must be the nature of the cation.

On the one hand, the cation contains an As-Br bond, and on the other, an As-I bond. Otherwise, they are presumably of a similar size and symmetry, and since in general, the As-Br bond energy is greater than the As-I bond energy (58k.cals./mole in AsBr_3 as opposed to 43k.cals./mole in AsI_3), it is clear that the bromotriphenylarsonium cation is the more favourable species. Thus, the greater strength of the As-Br bond is the critical factor in determining the mode of ionisation of triphenylarsenic diiododibromide in acetonitrile.

The mode of ionisation of triphenylarsenic iodotribromide is that of equation 13, and not the alternative

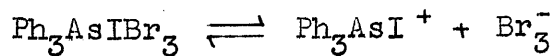

and this accords with the behaviour of the diiododibromide, in that ionisation occurs to give the cation containing the As-Hal bond of greatest strength.

Structural analysis of triphenylarsenic diiododibromide and iodotribromide.

X-ray structural analyses of triphenylarsenic diiododibromide and iodotribromide (by Mr. R.S. McEwan and Dr. G.A. Sim, (58)) show that they are isomorphous. Triphenylarsenic iodotribromide crystallises as orange monoclinic needles (space group $P2_1/c$) with the cell dimensions $a = 19.48 \text{ \AA}$, $b = 12.00 \text{ \AA}$, and $c = 18.47 \text{ \AA}$, $\beta = 107^\circ 36'$. There are eight formulae units per unit cell, the calculated density being 2.17 g./c.c. . The structure has been solved in three dimensions and the agreement factor over some 4,500 independent reflections is 0.25.

The structure consists of the separate entities, tetrahedral bromotriphenylarsonium cations and linear dibromiodide anions, their closest approach being 3.5 \AA between the cationic bromine and a bromine in the trihalide ion. The $\text{As-Br}\dots\dots\text{Br}$ angle is 76° .

The linear dibromiodide ion is symmetrical and the I-Br bond length is $2.75 \pm 0.05 \text{ \AA}$, compared with 2.5 \AA calculated from the sum of the ionic radii. The As-Br bond distance is 2.25 \AA which is in good agreement with other As-Br bond lengths.

Projection data of triphenylarsenic diiododibromide

is sufficient to indicate that the structure is built up from Ph_3AsBr^+ and I-I-Br^- ions. Refinement of both compounds is being carried out.

The results are of particular interest from two related points of view. They directly establish the structure of the dibromiodide and diiodobromide ions for the first time, and also, they show that the ions present in the solid state of these compounds are the same as those present in solution. Thus it is again shown that of the two possible ionic systems in these compounds, the favoured one is that in which the cation contains the halogen of lowest atomic number.

THE REACTION OF IODINE BROMIDE WITH TRIPHENYLARSENIC DIIODIDE
IN ACETONITRILE.

Since conductometric analyses have indicated the existence in solution of the tetrahalides Ph_3AsBr_4 , $\text{Ph}_3\text{AsIBr}_3$, $\text{Ph}_3\text{AsI}_2\text{Br}_2$, and Ph_3AsI_4 , all of which were subsequently prepared as crystalline solids, the existence of triphenylarsenic triiodobromide is of interest because its preparation would complete the series $\text{Ph}_3\text{AsI}_{(4-n)}\text{Br}_n$.

The stoichiometry of the compound suggested that conductometric titrations of iodine against triphenylarsenic iodobromide, or iodinebromide against triphenylarsenic diiodide in acetonitrile,

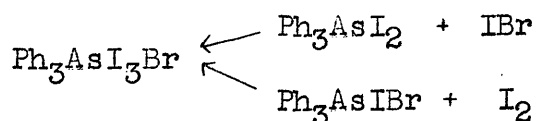

might yield useful information. The graphic results of these experiments were similar, and the results from the addition of iodine bromide to triphenylarsenic diiodide in acetonitrile, are recorded in Table 15 (page 61) and illustrated graphically in fig. 5.

The solution of the diiodide was prepared by adding iodine up to the ratio $\text{I}_2 : \text{Ph}_3\text{As} = 1:1$, following which, iodinebromide was the titrant. There was no change in slope,

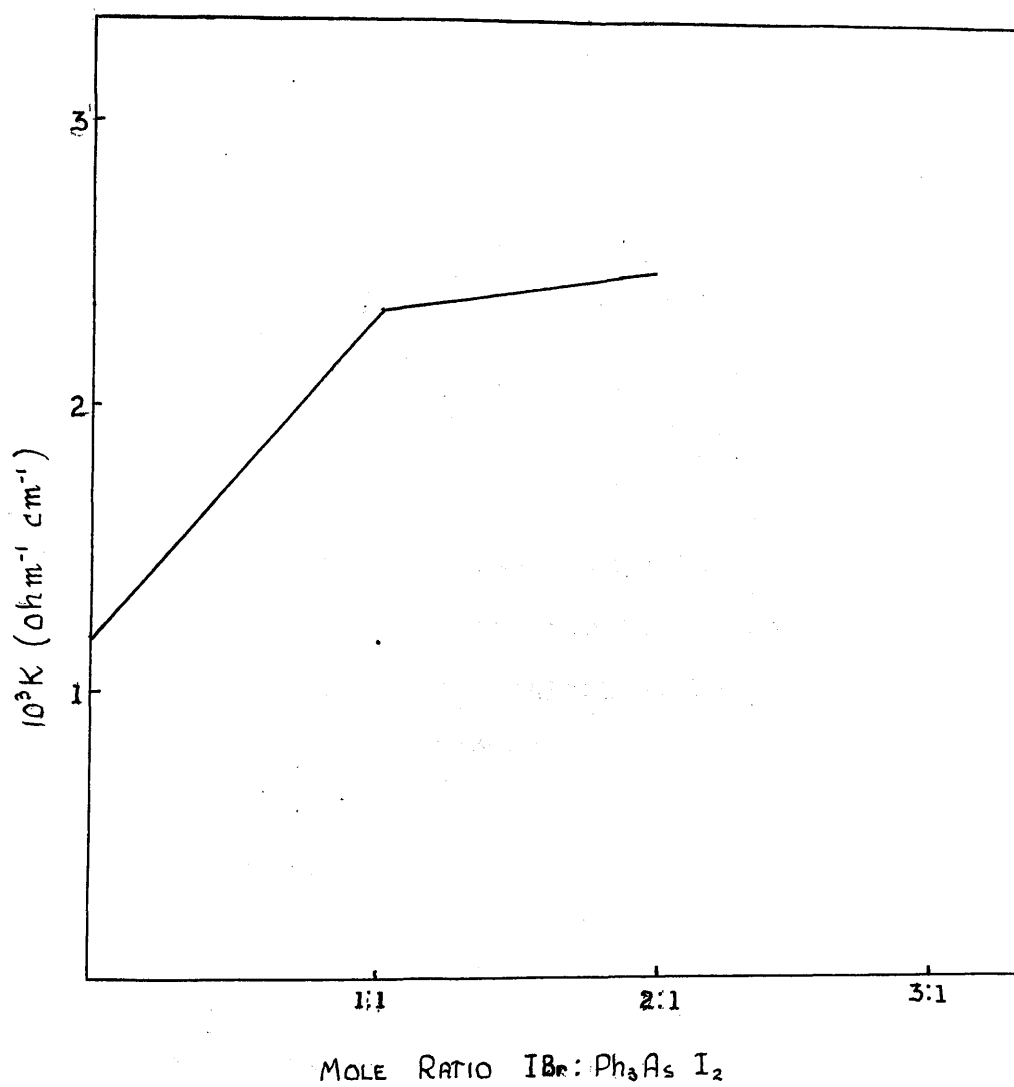

fig. 5. Conductometric Titration of IBr against Ph_3AsI_2
in acetonitrile.

Table 15. Titration of IBr vs. Ph_3AsI_2 in acetonitrile.

Mole ratio I Br: Ph_3AsI_2	$10^4 \kappa$ $\text{ohm}^{-1} \text{cm}^{-1}$	Mole ratio IBr: Ph_3AsI_2	$10^4 \kappa$ $\text{ohm}^{-1} \text{cm}^{-1}$
0.00	11.7	0.89	22.4
0.17	13.8	1.04	23.9
0.42	15.9	1.23	24.2
0.52	18.1	1.45	24.5
0.73	19.8	1.80	24.9

on changing the titrant.

The discontinuity in conductance at IBr: $\text{Ph}_3\text{AsI}_2 = 1:1$ indicates that an ionic species of composition $\text{Ph}_3\text{AsI}_2 \cdot \text{IBr}$ is formed in acetonitrile, but it has been impossible to isolate a solid of this composition from concentrated solutions at the 1:1 ratio. The compounds obtained were, in fact, tetrahalides, from total halogen analyses, but of bromine content too low for $\text{Ph}_3\text{AsI}_3\text{Br}$. (Found: Br, 2-3%. $\text{Ph}_3\text{AsI}_3\text{Br}$ requires Br, 10.4%). Interpretation of the reactions in solution leading the break at the 1:1 ratio are complex, since the diiodide is largely disproportionated in acetonitrile to triphenylarsine and triphenylarsenic tetraiodide.

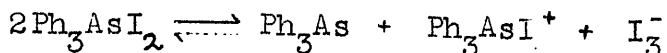

Iodinebromide added to the solution of "triphenylarsenic diiodide" would therefore be expected to react with the triphenylarsine to form triphenylarsenic diiododibromide. This leads to the reaction sequence shown in Table 16.

From previous discussions of the mode of ionisation of triphenylarsenic tetrahalides, it is clear that although triphenylarsenic triiodobromide could, in principle ionise in two ways

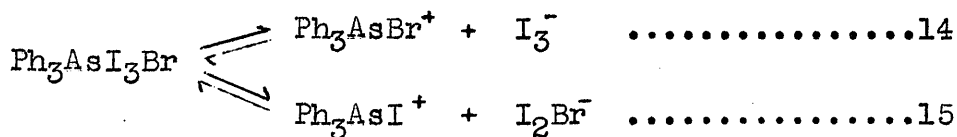

equation 14 would be expected.

Thus, when the situation arises as at (ii) (Table 16) in which the four possible ions of the $\text{Ph}_3\text{AsI}_3\text{Br}$ are simultaneously present in solution, the two least stable (equation 15) must undergo a process of halogen exchange to form the more stable ions.

This process is illustrated in reactions (ii) and (iii) in Table 16, (page 63). That this occurs, is supported by the presence in the U.V. spectrum of only the triiodide ion, at all points throughout the addition of iodinebromide. ($\lambda = 289$ and $360 \text{ m}\mu$).

incorporated into the lattice of the tetraiodide, thus, giving a non-stoichiometric composition e.g. $\left\{ (\text{Ph}_3\text{AsBr})_{0.3} (\text{Ph}_3\text{AsI})_{0.7} \right\}^+ \text{I}_3^-$. This is supported by the triiodide ion being the only species identified in the ultraviolet spectrum of such solids in acetonitrile.

The isolation of triphenylarsenic triiodobromide was only achieved by shaking a suspension of triphenylarsenic iodobromide in carbon tetrachloride, with an equimolar solution of iodine in the same solvent. The preparation of triphenylarsenic triiodobromide in this way, is presumably accounted for by the absence of mobile equilibria involving ionic species in this solvent.

Therefore, each member of the series $\text{Ph}_3\text{AsI}(4-n)\text{Br}_n$ is now known, and the ultraviolet spectrum of triphenylarsenic triiodobromide in acetonitrile, ($\lambda = 289$ and $360 \text{ m}\mu$: for I_3^- , $\lambda = 291$ and $360 \text{ m}\mu$), confirms that the mode of ionisation is the expected one.

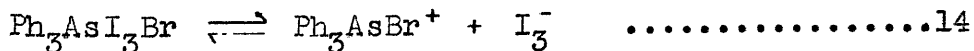

Some properties of members of the tetrahalide series are summarised in Table 17.

These foregoing experiments show the usefulness of the conductometric titration technique in providing information about the stoichiometry of ions in solution, but also ill-

ustrate the limitation that it is not always safe to conclude from a discontinuity in conductance at a particular composition, that there exists a solid compound of the same composition.

The reactions in solution giving a conductance-composition graph with breaks at simple ratios, may, in fact, be more complex than is apparent. Hence conclusions about compositions of species in solution based purely on these data must be treated cautiously, and direct identification (e.g. spectrophotometric) of the species is very desirable. The reaction of iodinebromide with triphenylarsenic diiodide illustrates well the latter point, which was found to assume even greater importance when the halogen/triphenylarsenic dichloride system was studied.

Table 17. Series $\text{Ph}_3\text{AsI}_{(4-n)}\text{Br}_n$.

COMPOUND	COLOUR.	M.P.	IONS in CH_3CN .
Ph_3AsI_4	Purple	139-40°	Ph_3AsI^+ I_3^-
$\text{Ph}_3\text{AsI}_3\text{Br}$	Red	115°	Ph_3AsBr^+ I_3^-
$\text{Ph}_3\text{AsIBr}_2$	Red	104°	Ph_3AsBr^+ I_2Br^-
$\text{Ph}_3\text{AsIBr}_3$	Orange	120-1°	Ph_3AsBr^+ IBr_2^-
Ph_3AsBr_4	Yellow	88°	Ph_3AsBr^+ Br_3^-

(See also Appendix 4.)

REACTION OF THE HALOGENS WITH TRIPHENYL ARSENIC
DICHLORIDE IN ACETONITRILE.

To investigate the possible existence of tetrainterhalides of triphenylarsine of type $\text{Ph}_3\text{AsHal}_{(4-n)}\text{Hal}^n$ involving chlorine atoms, conductometric titrations of iodine, iodinebromide and iodine chloride against triphenylarsenic dichloride were carried out. The nature of the results was similar in each case, and is exemplified in Table 18 and fig.6 for the addition of iodine bromide.

TABLE 18.

Titration of IBr vs. Ph_3AsCl_2 in acetonitrile.

mole ratio IBr : Ph_3AsCl_2	$10^3 \kappa$ $\text{ohm}^{-1}\text{cm}^{-1}$	mole ratio IBr : Ph_3AsCl_2	$10^3 \kappa$ $\text{ohm}^{-1}\text{cm}^{-1}$
0	0.12	0.94	3.96
0.13	0.90	1.00	4.02
0.25	1.57	1.12	4.08
0.44	2.42	1.25	4.05
0.62	3.12	1.37	4.05
0.81	3.63	1.50	4.02

The discontinuity in conductance at the mole ratio IBr : $\text{Ph}_3\text{AsCl}_2 = 1:1$ indicates the formation in solution

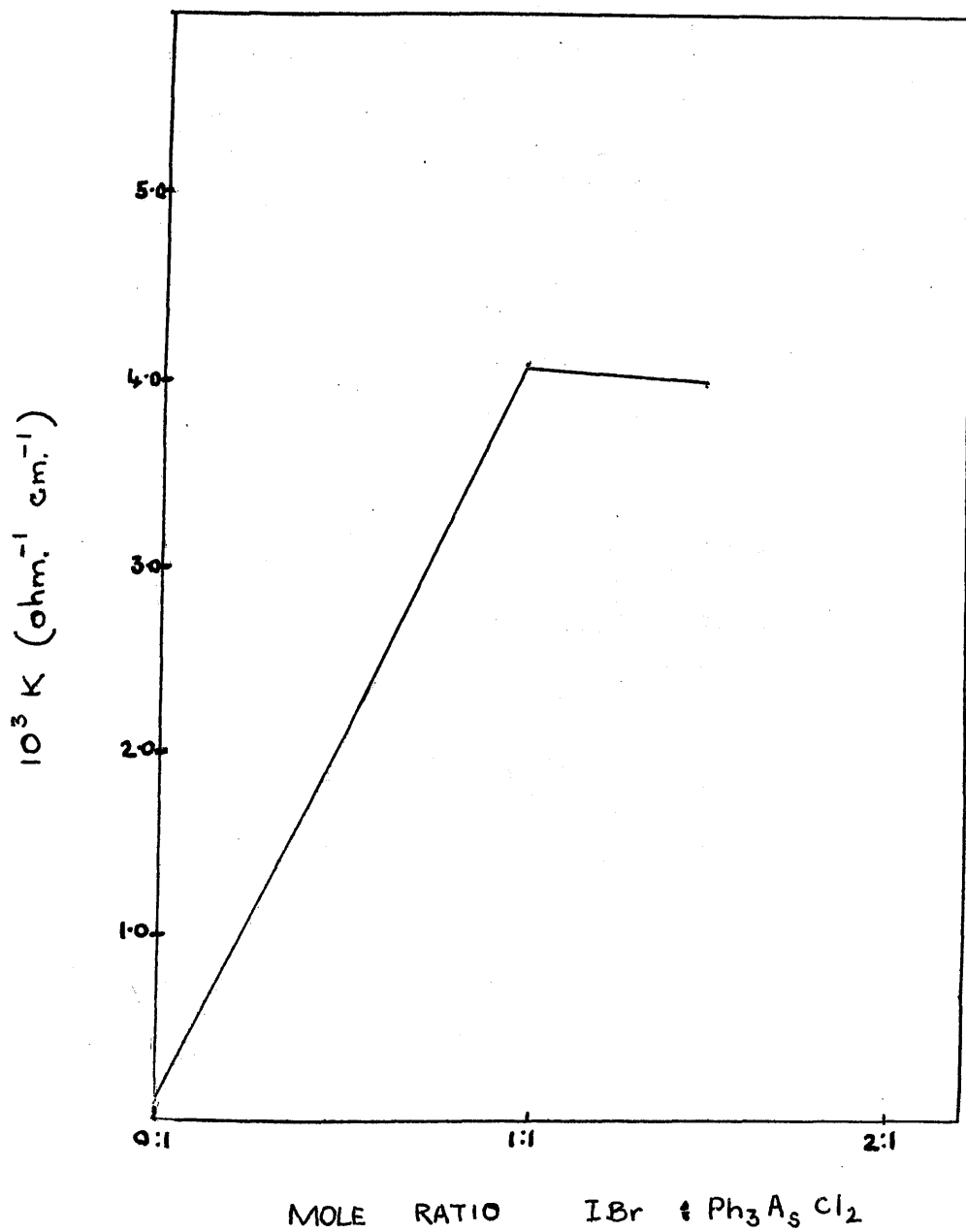

fig.6. Conductometric titration of IBr against Ph₃AsCl₂
in acetonitrile.

of an ionic complex of composition $\text{Ph}_3\text{AsCl}_2 \cdot \text{IBr}$, and likewise the formation in solution of $\text{Ph}_3\text{AsCl}_2 \cdot \text{I}_2$ and $\text{Ph}_3\text{AsCl}_2 \cdot \text{ICl}$ was also indicated.

The ultraviolet absorption spectra of the respective solutions were recorded at the 1:1 ratio, and gave the results shown in Table 19.

TABLE 19.

U.V. Spectra of Hal_2 : Ph_3AsCl_2 = 1:1 in acetonitrile.

Hal_2	λ m μ	Trihalide indicated	Hal_3^- in Acetonitrile(49)
I Br	235	IBrCl^-	237
I Cl	227	ICl_2^-	227
I_2	227	ICl_2^-	227 [*]
	265	I_2Cl^-	261 [*]
	292, 360	I_3^-	288, 360 [*]

* The presence of three trihalide ions is explained by disproportionation of the diiodochloride ion (49)

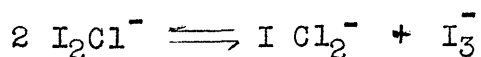

These conductometric titrations therefore constitute good evidence for the existence of $\text{Ph}_3\text{AsCl}^+ \text{IBrCl}^-$, $\text{Ph}_3\text{AsCl}^+ \text{ICl}_2^-$, and $\text{Ph}_3\text{AsCl}^+ \text{I}_2\text{Cl}^-$ in solution, but solid compounds isolated from concentrated equimolar acetonitrile solutions of halogen and triphenylarsenic dichloride,

have the compositions $\text{Ph}_4\text{As}^+ \text{IBrCl}^-$, $\text{Ph}_4\text{As}^+ \text{ICl}_2^-$ and $\text{Ph}_4\text{As}^+ \text{I}_2\text{Cl}^-$ respectively. That is, the products possess the same anion as was indicated in solution, but the cation is now the tetraphenyl arsonium ion.

The formation of tetraphenyl arsonium trihalides also occurs in the direct addition of two and three moles of iodine chloride respectively to triphenyl arsine, giving the products tetraphenylarsonium diiodochloride and dichloroiodide. The preparation of the latter is another example of the conversion of a less stable to a more stable trihalide ion.

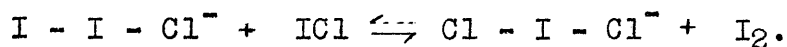

That the anions of these solid tetraphenylarsonium salts were the same as those present in the $\text{Ph}_3\text{AsCl}^+ \text{Hal}_3^-$ solution, follows from the $\text{Ph}_3\text{AsI}(4-n)\text{Br}_n$ series, in which the most electronegative halogen was incorporated into the cation. While the chlorotriphenylarsonium cation may be stable in solution, however, it must disproportionate during isolation presumably,

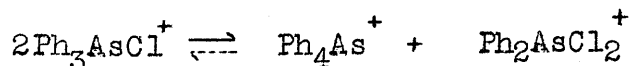

to give initially the tetraphenylarsonium and dichlorodiphenylarsonium cations. The latter must undergo further disproportionation, however, since the yields of tetraphenylarsonium diiodochloride and dichloroiodide were both greater than 50% (61% and 56% respectively).

Therefore there is no evidence for solids which contain chlorine and are members of the series $\text{Ph}_3\text{AsI}_{(4-n)}\text{Cl}_n$, since triphenylarsenic dichloride does not add chlorine to form a tetrachloride, and the attempted preparations of triphenylarsenic iodotrichloride and diiododichloride have yielded tetraphenylarsonium salts.

Also, it has not been possible to prepare triphenyl arsenic triiodochloride; the products isolated from the reaction of iodine chloride with triphenylarsenic diiodide in acetonitrile were in fact triphenylarsenic tetraiodide and tetraphenylarsonium diiodochloride - the former arising from disproportionation of the triphenyl arsenic diiodide in acetonitrile, and the latter from the reaction of iodinechloride with the triphenylarsine.

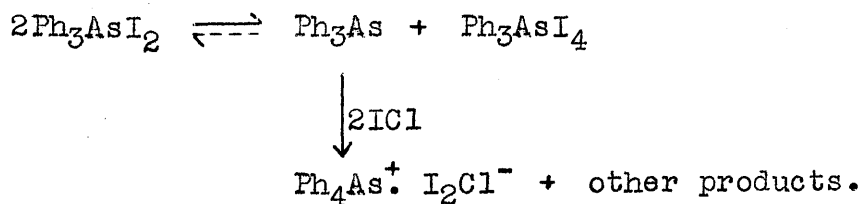

The addition of halogens to triphenylarsenic dihalides to form tetrahalides is thus not as general as the preparation of the $\text{Ph}_3\text{AsI}_{(4-n)}\text{Br}_n$ series would suggest, and the situation is complicated by ready phenyl migration. Clearly further work must be done on these systems involving halogens other than iodine and bromine.

SUMMARY:

The conductance values of the triphenylarsenic dihalides studied in acetonitrile show two types of behaviour. Triphenylarsenic dichloride and dibromide behave as weak electrolytes, and transport experiments show that the nature of their anions differ.

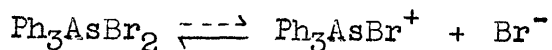
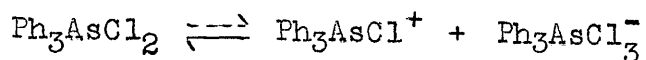

Triphenylarsenic diiodide and the novel triphenylarsenic iodobromide form conducting solutions by their quantitative disproportionation to triphenylarsine and a triphenylarsenic tetrahalide (strong electrolyte). That these four dihalides form conducting solutions in three different ways demonstrates the need to determine experimentally the mode of ionisation of such compounds.

Conductometric analyses have indicated the existence in acetonitrile of a tetrahalide series $\text{Ph}_3\text{AsI}_{(4-n)}\text{Br}_n$, and all members of this series have been prepared as crystalline solids. The nature of the reactions in solution during halogen addition to triphenylarsine or triphenylarsenic dihalides (Hal. = Br, I) has been discussed. In many cases, mobile equilibria are involved, and halogen exchange between anion and cation has been demonstrated. The tetrahalides behave as halotriphenylarsonium trihalides in acetonitrile, and the mode of ionisation of the tetra-

interhalides is dependent on the cation and not on the relative trihalide ion stabilities. The bromotriphenyl arsonium cation is more favourable on account of the greater strength of the As - Br bond compared to the As - I bond.

The existence in acetonitrile of triphenylarsenic tetrahalides containing chlorine atoms was indicated conductometrically by halogen addition to triphenylarsenic dichloride. The crystalline compounds isolated, however, proved to be tetraphenylarsonium trihalides. The rapid phenyl migration in this system is an unexpected feature, and aptly illustrates the caution which must be exercised in relating solution data to the solid state.

EXPERIMENTAL PART

PREPARATION OF TRIPHENYLARSINE-HALOGEN ADDUCTS.

1) TRIPHENYL ARSENIC DIHALIDES.

Preparation of triphenylarsenic dichloride.

Triphenylarsine was dissolved in a suitable solvent (e.g. chloroform or carbon tetrachloride), and dry chlorine gas was bubbled into the solution in a stream of dry nitrogen. White crystals of triphenylarsenic dichloride precipitated and the solution turned green when the reaction was complete, due to the presence of free chlorine. It was necessary to cool the reaction flask from time to time, since the reaction was strongly exothermic. The hygroscopic dichloride was filtered in the drybox, washed with anhydrous ether, and stored in a sealed tube in a desiccator. (m.p. 204-5°. (Found : Cl, 19.1. Calc. for $C_{18}H_{15}AsCl_2$, Cl, 18.8%; m.p. 204-5°.)

Preparation of triphenylarsenic dibromide.

A solution of bromine (1.809 g., 0.0113 mole) dissolved in acetonitrile (30 ml.) was added to a solution of triphenylarsine (3.468 g., 0.0113 mole) dissolved in acetonitrile (20 ml.). Heat was evolved, and white crystals precipitated. They were filtered in the drybox, washed with anhydrous ether, and stored in a sealed tube, m.p. 215°. (for Ph_3AsBr_2 , m.p. 215°) (44).

The dibromide is hygroscopic and turns yellow on the surface on standing. Any reactions in which it was used were carried out in the drybox on a freshly prepared sample.

Preparation of triphenylarsenic iodobromide.

A solution of iodinebromide (0.0251 mole) in acetonitrile (15 ml.) was added to a saturated acetonitrile solution of triphenylarsine (3.85 g., 0.0251 mole). Heat was evolved, the solution turned orange-yellow, and yellow crystals precipitated. These were filtered in the drybox, washed with anhydrous ether, and dried in vacuo, m.p. 154-5°C., yield 95%. (Found: C,42.1; H,2.9; Br,15.1; I,24.2. $C_{18}H_{15}AsBrI$ requires C,42.2; H,2.9; Br,15.6; I,24.8%).

Preparation of triphenylarsenic diiodide.

Triphenylarsenic diiodide was prepared as described by Steinkopf and Schwen (45). A saturated solution of iodine (2.500 g., 0.00985 mole) in anhydrous petroleum ether (100°-120°) was added to a saturated solution of triphenylarsine (3.014 g., 0.00985 mole) in the same solvent. Heat was evolved and crystals of triphenylarsenic tetraiodide precipitated. The solution was decanted to another flask and the addition of iodine continued. Yellow crystals

precipitated. These were filtered in the drybox, washed with anhydrous ether, and dried in vacuo, m.p. 130-140°. (Found: I, 45.4; Calc. for $C_{18}H_{15}AsI_2$: I, 45.4%; m.p. 130-140°.)

2) TRIPHENYLARSENIC TETRAHALIDES:

Preparation of triphenylarsenic tetraiodide.

A solution of iodine (5 g., 0.0197 mole) dissolved in acetonitrile (50 ml.) was added to a solution of triphenylarsine (3.019 g., 0.00987 mole) dissolved in acetonitrile (20 ml.). Heat was evolved and purple needle crystals precipitated almost immediately. The needles were filtered off in the drybox, washed with anhydrous ether, and dried in vacuo. m.p. 139-140°. (Found: I, 62.1; Calc. for $C_{18}H_{15}AsI_4$: I, 62.3%; m.p. 142-4°C.)

Preparation of triphenylarsenic triiodobromide.

A solution of iodine (0.992 g., 0.00391 mole) in carbon tetrachloride (200 ml.) was added to a suspension of triphenylarsenic iodobromide (2.005 g., 0.00391 mole) in carbon tetrachloride (50 ml.). The solution was shaken for twenty four hours and a red crystalline solid formed, which was filtered off in the drybox, washed with anhydrous ether, and dried in vacuo. m.p. 115-116°, yield 81%

(Found: Br,10.8; I,49.1; $C_{18}H_{15}AsBrI_3$ requires Br,10.4; I,49.7%).

Attempted preparations have included the addition of a solution of iodinebromide (0.0154 mole) in acetonitrile (40 ml.) to triphenylarsine (4.706 g., 0.0154 mole) in acetonitrile (30 ml.), followed by the addition of iodine (3.913 g., 0.0154 mole) in acetonitrile (100 ml.) to the resultant red solution. Purple crystals separated on shaking, m.p. 129°. (Found: C,27.0; H,1.9; Br,2.8. $C_{18}H_{15}AsBrI_3$ requires C,28.2; H,2.0; Br,10.4%).

Also, a solution of iodinebromide (0.00358 mole) in acetonitrile (15 ml.) was added to triphenylarsenic diiodide (2 g., 0.00358 mole) dissolved in acetonitrile (20 ml.). Purple crystals precipitated shortly after mixing, m.p. 138-9°C. (Found: C,27.3; H,1.8; Br,3.4. $C_{18}H_{15}AsBrI_3$ requires C,28.2; H,2.0; Br,10.4%).

Preparation of triphenylarsenic diiododibromide.

A solution of iodinebromide (0.0175 mole) dissolved in acetonitrile (50 ml.) was added to a solution of triphenylarsine (2.683 g., 0.00877 mole) in acetonitrile (30 ml.). Heat was evolved, and the addition of anhydrous ether (200 ml.) precipitated red needle crystals which were filtered in the drybox, washed with anhydrous ether, and dried in vacuo. m.p. 104°. (Found: C,30.9; H,2.2;

As, 10.2; Br, 22.1; I, 35.0. $C_{18}H_{15}AsBr_2I_2$ requires
C, 30.0; H, 2.1; As, 10.4; Br, 22.2; I, 35.3%).

An alternative route to this compound is the addition of iodine in acetonitrile to triphenylarsenic dibromide in acetonitrile. The compound may be isolated either by freeze-drying or by ether precipitation.

Preparation of triphenylarsenic iodotribromide.

A solution of iodinebromide (0.0114 mole) dissolved in acetonitrile (20 ml.) was added to a suspension of triphenylarsenic dibromide (5.291 g., 0.0114 mole) in acetonitrile (50 ml.). Heat was evolved, the colourless solution became orange, and the dibromide dissolved. Anhydrous ether was added to the solution until orange crystals precipitated. These were filtered in the drybox, washed with anhydrous ether and dried in vacuo. m.p. 120-1°C.
(Found: C, 32.4; H, 2.4; As, 11.1; Br, 35.4; I, 18.7.
 $C_{18}H_{15}AsBr_3I$ requires: C, 32.1; H, 2.2; As, 11.1; Br, 35.7; I, 18.9%).

An alternative route to this compound is the addition of three moles of iodinebromide in acetonitrile to triphenylarsine in the same solvent. Again, the compound may be isolated either by freeze-drying or by ether precipitation.

Preparation of triphenylarsenic tetrabromide.

A solution of bromine (3.501 g., 0.0219 mole) in acetonitrile (20 ml.) was added to a solution of triphenylarsine (3.36 g., 0.0110 mole) in acetonitrile (30 ml.). Heat was evolved and triphenylarsenic dibromide firstly precipitated but redissolved as addition continued, and the solution became yellow. Anhydrous ether was added to the solution until an orange oil separated. When the oil was shaken with ether hygroscopic orange crystals formed. These were filtered in the drybox, washed with anhydrous ether, dried in vacuo and stored over phosphorus pentoxide. m.p. 88°.

(Found: C,34.9; H,2.8; Br,51.6. Calc. for $C_{18}H_{15}AsBr_4$, C,34.5; H,2.4; Br,51.1%; m.p. 89°). (46)

3) TETRAPHENYLARSONIUM TRIHALIDES:

Preparation of tetraphenylarsonium diiodochloride.

Iodine (1.365 g., 0.00538 mole) dissolved in acetonitrile (30 ml.) was added to a suspension of triphenylarsenic dichloride (2.026 g., 0.00538 mole) in acetonitrile (20 ml.). Heat was evolved, the solution turned red, and the dichloride dissolved. The solution was freeze-dried and the resultant red mass extracted with anhydrous ether and carbon tetrachloride. The resultant red crystalline

solid was filtered in the drybox, washed with ether, and dried in vacuo. m.p. 93°. Yield, 61%.

(Found: C,43.8; H,3.4; As,11.0; Cl,5.3; I,36.5.

$C_{24}H_{20}AsClI_2$ requires C,42.8; H,3.0; As,11.1; Cl, 5.3; I,37.9%).

The compound may also be isolated from an acetonitrile solution containing iodine chloride and triphenylarsine in a 2:1 mole ratio.

Preparation of tetraphenylarsonium dichloroiodide.

Iodine chloride (0.00497 mole) dissolved in acetonitrile (15 ml.) was added to a suspension of triphenylarsenic dichloride (1.866 g., 0.00497 mole) in acetonitrile (20 ml.). Heat was evolved, the solution became yellow and the dichloride dissolved. The solution was freeze-dried, and the resultant yellow mass shaken with ether. The insoluble yellow crystals were filtered in the drybox, washed with anhydrous ether and dried in vacuo. m.p. 84-5°. Yield, 56%. (Found: C,49.7; H,3.7; As,12.8; Cl,12.1; I,21.7. $C_{24}H_{20}AsCl_2I$ requires C,49.7; H,3.5; As,12.9; Cl,12.1; I,21.9%).

An alternative route to this compound is the reaction of three moles of iodine chloride with triphenylarsine in acetonitrile. The isolation procedure is similar to that described above.

Preparation of tetraphenylarsonium iodobromochloride.

Iodinebromide (0.00984 mole) dissolved in acetonitrile (15 ml.) was added to a suspension of triphenylarsenic dichloride (3.695 g., 0.00984 mole) in acetonitrile (25 ml.). Heat was evolved, the solution became orange, and the dichloride dissolved. Anhydrous ether was added to the solution until orange crystals precipitated. These were filtered in the drybox, washed with anhydrous ether, and dried in vacuo, m.p. 104°. (Found: C,46.2; H,3.3; Cl,7.0; Br,10.8; I,18.4. $C_{24}H_{20}AsBrClI$ requires C,46.1; H,3.2; Cl,5.7; Br,12.7; I,20.3%).

Crystal size.

The rate of formation of the crystalline addition compounds, and the size of the crystals obtained, depends largely on the concentrations used in those cases where the compound precipitates on mixing and on the amount of ether added where the compound is isolated by ether precipitation. The largest crystals were obtained by the latter method when ether was added until a slight cloudiness appeared and the flask was allowed to stand overnight at 0°C.

PURIFICATION OF MATERIALS:

Triphenylarsine halogen adducts.

Purification was accomplished by repeated redissolution in acetonitrile, followed by reprecipitation with ether until crystals of constant melting point were obtained.

Acetonitrile.

The most satisfactory starting material was found to be the product of B.D.H. Ltd. This material was further purified by a modification of the procedure described by Smith and Witten (59). The crude material was left standing over AnalaR potassium hydroxide pellets for seven days. It was then filtered and distilled directly into a flask containing calcium chloride (14 - 20 mesh), over which it was allowed to stand for a further period of several days. The liquid was then again filtered and distilled onto phosphorus pentoxide, and this procedure was repeated until the phosphorus pentoxide in the receiving flask did not remain bound to the flask when the latter was swirled. At this stage too, the distillate did not produce a yellow colour in the desiccant. The acetonitrile was then stored in a glass stoppered flask over the phosphorus pentoxide until it was required for use. The acetonitrile was then distilled from the storage flask, and the distillate

(which was very slightly cloudy) was distilled in vacuo from ca. 0°C. to -80°C. This removed traces of phosphorus pentoxide which otherwise sublimed over during distillation from the desiccating agent at ordinary pressures.

b.p. = 81 - 82°C. (760 mm.)

K = ca. 10^{-7} ohm $^{-1}$ cm $^{-1}$ at 25°C.

(impure material, K = 3.5×10^{-5} ohm $^{-1}$ cm $^{-1}$)

Carbon Tetrachloride.

AnalaR grade carbon tetrachloride was used directly without further purification.

Diethyl Ether.

The "anhydrous ether" of M. and B. Ltd. was thoroughly dried with sodium wire and used without further purification.

Bromine.

AnalaR bromine (B.D.H.) was placed in a small flask attached to the vacuum system and pumped to remove the more volatile impurities. The bromine was then cooled to 0°C. and distilled in vacuo into ampoules cooled to -85°C. (acetone-Drikold mixture). The ampoules had been weighed empty and were joined to the vacuum system by B7 cones. When filled, the ampoules were sealed off at the narrow neck. The detached cone was then carefully freed from tap grease and weighed along with the bulb plus its contents.

Weighed samples of bromine were thus stored.

Iodine.

Commercial (Whiffen) resublimed iodine was used without further purification.

Iodine Bromide.

Iodine bromide was prepared in situ by mixing equimolar solutions of purified iodine and bromine in acetonitrile.

Iodine Chloride.

Iodine chloride was prepared by the method of Cornog and Karges (60). Liquid chlorine (100 ml.) was collected under anhydrous conditions in a weighed glass tube of 300 ml. capacity, cooled in an acetone/Drikold slurry (ca. -80°). Iodine (235 g., ca. $\frac{1}{2}$ molar equivalent) was added to the liquid chlorine. It was found more convenient to cool the iodine in solid carbon dioxide before addition, to reduce the violent reaction with chlorine, and also to add the iodine via a wide-necked funnel.

The mixture became initially yellow, due to formation of iodine trichloride, but latterly turned deep red.



The tube was warmed to room temperature, when most of the excess chlorine evaporated. The tube and its contents were then weighed, the weight of unreacted chlorine still remaining calculated, and the required quantity of iodine added to satisfy the formula ICl . The mixture was melted by warming to almost $30-35^{\circ}C.$, and after standing overnight crystals of α -iodine chloride formed. These were recrystallised by successively melting, cooling and discarding the liquid fraction. m.p. 28° . (α -iodine chloride requires m.p. 28° .)

Chlorine.

A commercial chlorine cylinder was used and the gas was dried by bubbling through concentrated sulphuric acid. It was diluted in a stream of dry nitrogen for synthetic reactions.

Triphenyl arsine.

Triphenylarsine was prepared by the Wurtz reaction, between arsenic trichloride and chlorobenzene (61), and the crude product was recrystallised from 95% ethanol to constant melting point ($61^{\circ}C.$).

PREPARATION OF WEIGHED SAMPLES OF LIQUIDS:

In the work leading to this part and the other parts of the thesis it was often necessary to add a known

weight of a liquid compound to a system. The most convenient way of doing this was to introduce the known weight of material enclosed in a bulb ampoule, and then to break the bulb.

MEASUREMENT OF CONDUCTANCE.

The conductance cell was of the dipping electrode type (see below), and the electrodes of the cell consisted of smooth platinum discs each of radius 0.4 cm. The cell constant was $0.528, \text{cm.}^{-1}$ (Found by using standard potassium chloride solutions (62).) Conductance measurements were made in a thermostat bath at 25°C. using a Phillips Resistance Bridge (type GM 4249).

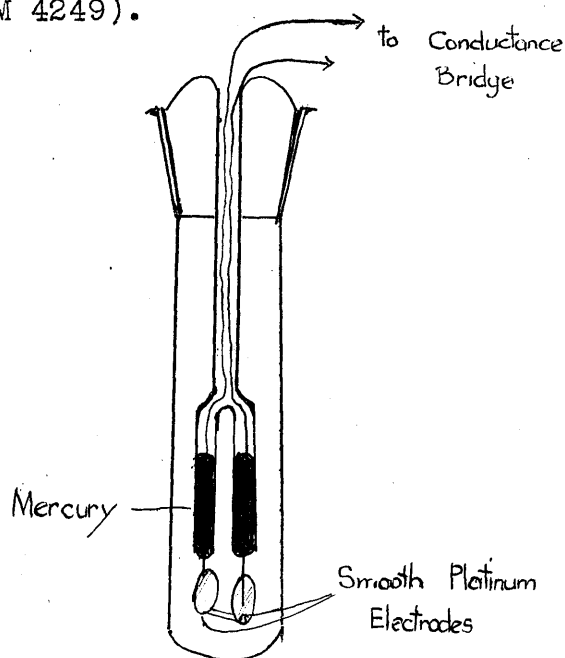

Conductance Cell.

A specimen tube filled with solute and stoppered in the drybox was weighed. The solute was then transferred to the conductance cell in the drybox and the specimen tube was stoppered and reweighed. The cell was also stoppered in the drybox and weighed. Approximately 10 ml. of dry acetonitrile were added to the cell, again in the drybox, and the cell was reweighed. The concentration of the solution could then be calculated from the weight of solute in the known weight of acetonitrile. The cell was then finally placed in the thermostat, and the conductance measurements begun.

ELECTROLYSIS EXPERIMENTS:

The electrolysis cell used in these experiments is described in Appendix 3. Results were considered valid only if the middle solution varied negligibly in concentration after the experiment from the concentration in the original solution. Solutions were prepared in the drybox, as described under "conductance measurements". The method of determining halogen content is described in the section entitled "methods of analysis".

ABSORPTION SPECTRA:

Absorption spectra were recorded using a Perkin-Elmer Model 137 U.V. - vis Spectrophotometer, and a Hitachi-Perkin-

Elmer Model 139 U.V.-vis Spectrophotometer. The solutions were prepared in 25 ml. standard flasks and the measurements were made in 0.2 cm. and 0.5 cm. stoppered quartz cells. Measurements were made at 20°C. (room temperature).

CONDUCTOMETRIC TITRATIONS:

The apparatus used in this method of analysis is described in Appendix 2, where the procedure is given in some detail. The concentrations of the solutions used were carefully prearranged so that the desired range of mole ratio would be covered. Solutions of bromine and iodine bromine were prepared in the drybox by breaking ampoules of bromine under known amounts of solvent. Solid solutes were weighed by difference, as described under "conductance measurements". In all cases the halogen was employed as titrant, and the experiments were declared invalid if a solid phase separated at any stage.

Halogen vs. triphenylarsenic diiodide, -iodobromide,
-dibromide.

In each case, the dihalides were formed in situ by adding a molar equivalent of the requisite halogen to triphenylarsine and subsequently changing the titrant.

The conductance-composition relationships for the systems iodine against triphenylarsenic iodobromide, and iodine against triphenylarsenic dibromide are given in Tables 19 and 20.

TABLE 19.

Titration of I₂ vs. Ph₃AsIBr in acetonitrile.

mole ratio I ₂ :Ph ₃ AsIBr.	10 ³ κ ohm. ⁻¹ cm. ⁻¹	mole ratio I ₂ :Ph ₃ AsIBr	10 ³ κ ohm. ⁻¹ cm. ⁻¹
0.00	1.62	0.88	2.84
0.22	2.00	0.99	2.98
0.44	2.30	1.21	2.95
0.66	2.53	1.43	2.96

TABLE 20.

Titration of I₂ vs. Ph₃AsBr₂ in acetonitrile.

mole ratio I ₂ :Ph ₃ AsBr ₂	10 ³ κ ohm. ⁻¹ cm. ⁻¹	mole ratio I ₂ :Ph ₃ AsBr ₂	10 ³ κ ohm. ⁻¹ cm. ⁻¹
0.00	0.41	0.91	1.75
0.18	0.87	1.02	1.87
0.36	1.15	1.19	1.95
0.55	1.34	1.46	1.91
0.73	1.51	1.64	1.91

Halogen against triphenylarsenic dichloride.

Solutions of the dichloride were prepared in the drybox and halogen was titrated against these in the normal way.

The results of the titrations of iodine chloride and iodine versus triphenylarsenic dichloride are recorded below:-

TABLE 21.

Titration of ICl vs. Ph_3AsCl_2 in acetonitrile.

mole ratio $\text{ICl}:\text{Ph}_3\text{AsCl}_2$	$10^3 \kappa$ $\text{ohm}^{-1}\text{cm}^{-1}$	mole ratio $\text{ICl}:\text{Ph}_3\text{AsCl}_2$	$10^3 \kappa$ $\text{ohm}^{-1}\text{cm}^{-1}$
0.00	0.05	0.92	1.30
0.20	0.30	1.10	1.45
0.41	0.55	1.30	1.44
0.60	0.80	1.50	1.43
0.78	1.12	1.70	1.42

TABLE 22.

Titration of I_2 vs. Ph_3AsCl_2 in acetonitrile.

mole ratio $\text{I}_2:\text{Ph}_3\text{AsCl}_2$	$10^3 \kappa$ $\text{ohm}^{-1}\text{cm}^{-1}$	mole ratio $\text{I}_2:\text{Ph}_3\text{AsCl}_2$	$10^3 \kappa$ $\text{ohm}^{-1}\text{cm}^{-1}$
0.00	0.10	0.98	2.23
0.20	0.80	1.15	2.38
0.40	1.40	1.30	2.42
0.60	1.80	1.53	2.50
0.78	2.06	1.77	2.53

METHODS OF ANALYSIS:

Simple halogen adducts.

Halogen adducts containing only a single halogen were accurately weighed and added to a 50 ml. flask; 10-25 ml. 2N sodium hydroxide (in large excess) were added in an enclosed system, such that volatile hydrolysis products could not escape into the atmosphere. The solution was boiled to ensure complete hydrolyses, acidified with conc. sulphuric acid, and any hypohalite formed was reduced with sulphur dioxide. The excess sulphur dioxide was boiled off and the solution made alkaline with concentrated ammonium hydroxide. The solution was made up in a standard flask, and aliquot portions were analysed for halide ion by Volhard's method.

Mixed halogen adducts (iodine and bromine).

Such adducts were hydrolysed as described under "simple halogen adducts". The solutions were analysed for total halogen by Volhard's method and for bromide and iodide in the presence of each other, by a modification of Jannasch's method of selective oxidation (63). 25 ml. of the solution were treated with 3 ml. glacial acetic acid and 5 ml. 20 vol. hydrogen peroxide. The selectively oxidised iodine was steam distilled in an all-glass apparatus

into ammoniacal hydrazine, and the resultant iodide ion determined by Volhard's method, after acidification with nitric acid.

The residual solution was neutralised with ammonium hydroxide, and 25 ml. sulphuric acid, 15 ml. water and 30 ml. hydrogen peroxide were added. The liberated bromine was distilled into alkaline hydrazine and determined by Volhard's method after acidification with nitric acid. Equally sound results were obtained by destroying the excess hydrogen peroxide by boiling, neutralising the residual solution with ammonium hydroxide, and analysing directly for bromine, as described above.

Transport experiments.

After electrolysis, the contents of the middle, cathode and anode compartments were removed in standard flasks (100 cc.) for analysis. Distilled water was added to each solution until the water insoluble product of the hydrolysis (triphenylarsine oxide) was just about to come out of solution. The solutions were then made up to the mark with an acetone-water mixture. Aliquot portions of these solutions were then hydrolysed as described under "simple halogen adducts", with excess sodium hydroxide and sulphur dioxide reduction. The halide ion was again determined by Volhard's method.

PART 2.

TRIPHENYLPHOSPHINE-HALOGEN ADDUCTS.

I N D E X

	<u>page</u>
RESULTS AND DISCUSSION.	92-123
1. Preparation and Stability of Triphenylphosphorus Dihalides.	92
2. Electrolytic Conductance of Triphenylphosphorus Dihalides in Acetonitrile.	95
3. Electrolyses of Triphenylphosphorus Dihalides in Acetonitrile.	98
4. Conductometric Analyses of the Systems Hal_2 vs. Ph_3P and Hal_2 vs. $\text{Ph}_3\text{P}\text{Hal}_2$ in Acetonitrile.	102
5. Reaction of Iodine with Triphenylphosphine in Acetonitrile.	107
6. Reaction of Iodinebromide and Bromine with Triphenylphosphorus Diiodide in Acetonitrile.	108
7. Reaction of Iodinebromide with Triphenylphosphine in Acetonitrile.	110
8. Reaction of Iodine and Bromine with Triphenylphosphorus Iodobromide in Acetonitrile.	112
9. Reaction of Bromine with Triphenylphosphine in Acetonitrile.	113
10. Reaction of Iodine and Iodinebromide with Triphenylphosphorus Dibromide in Acetonitrile.	114
11. Electrolytic Conductance of Triphenylphosphorus Tetrahalides in Acetonitrile.	115
12. The Nature of Triphenylphosphorus Tetrahalides in the Solid State.	117
13. Reaction of Halogens with Triphenylphosphine in Moist Acetonitrile.	120
SUMMARY.	124

	<u>Page</u>
EXPERIMENTAL PART.	126-140
1. Preparation of Triphenylphosphorus-Halogen Adducts.	126
(a) Triphenylphosphorus Dihalides.	126
(b) Triphenylphosphorus Tetrahalides.	127
(c) Triphenylphosphonium Halides.	132
(d) Other preparations.	134
2. Purification of Materials.	135
(a) Triphenylphosphine.	135
(b) Triphenylphosphorus Dihalides and Tetrahalides.	135
3. Conductance Measurements.	135
4. Electrolysis Experiments.	135
5. Conductometric Titrations.	136
6. Methods of Analysis.	139
7. U.V.- Vis. Spectroscopy.	139.

RESULTS AND DISCUSSION.

PREPARATION AND STABILITY OF TRIPHENYL PHOSPHORUS DIHALIDES.

Compounds of pentavalent phosphorus of the general formula R_3PX_2 (R = alkyl or aryl group; X = Cl, Br or I) have been prepared by a variety of methods. For example, triphenylphosphorus dichloride has been formed by the reactions:

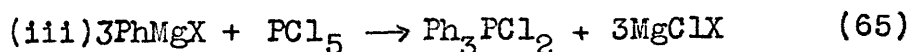
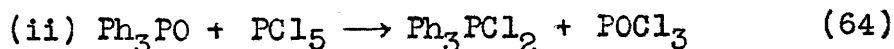
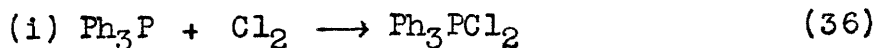

Thus, two general methods of preparing tertiary phosphorus dihalides are available. On the one hand, the phosphorus atom is initially in the pentavalent state and the reaction involves the replacement of substituents on the phosphorus ((ii) and (iii)), whereas the second general method (i) utilises the ability of the halogens to take part in an addition reaction with tertiary phosphines, in which the halogen oxidises the phosphorus from the trivalent to the pentavalent state. Hence elementary chlorine, bromine and iodine react under suitable conditions with tertiary aliphatic, cycloaliphatic and aromatic phosphines in the mole ratio $X_2 : R_3P = 1 : 1$, and such reactions have been reported by many authors. In some cases the addition

compounds were reported as oils, and in others as solids. For example, triphenylphosphorus dichloride is described by Michaelis (66) as a green syrup but by Jensen (36) as a white crystalline solid. Contradictory evidence of this type induced Issleib and Seidel (40) to reinvestigate the reactions of tertiary phosphines with chlorine, bromine and iodine, and they too prepared many new addition compounds in the course of their studies.

Triphenylphosphorus dichloride was prepared as described by Jensen; the dibromide (67) and diiodide (40) were readily obtained by mixing saturated acetonitrile solutions of halogen and triphenylphosphine. Triphenylphosphorus iodobromide could not be prepared by mixing equimolar acetonitrile solutions of iodinebromide and triphenylphosphine: instead, a yellow crystalline dihalide of novel composition $\text{Ph}_3\text{PI}_{1.5}\text{Br}_{0.5}$ precipitated. There is, however, evidence from the conductometric titrations described in the next section that the iodobromide does exist in solution, and that the isolation of $\text{Ph}_3\text{PI}_{1.5}\text{Br}_{0.5}$ may be directly due to crystal lattice stabilities.

The triphenylphosphorus dihalides are all solids at room temperature. Both the dibromide and dichloride are very hygroscopic, and precautions as detailed in Part I were at all times observed. The diiodide and $\text{Ph}_3\text{PI}_{1.5}\text{Br}_{0.5}$

are much less hygroscopic, but when stored for a long period, even over phosphorus pentoxide in an inert atmosphere, they appear to decompose to some extent. As an alternative method of storage, the latter dihalides were kept under anhydrous ether in which they are effectively insoluble, but after a period of time a red crystalline solid began to form among the yellow dihalide crystals. In the case of the diiodide, this solid has the composition Ph_2PI , but is unlike diphenyliodophosphine, which has been reported as a red oil (68). Also, the red solid gives a conducting solution in acetonitrile, in which the triiodide ion has been identified. The red solids have not been further investigated and offer an interesting topic for future research.

On account of the instability of the dihalides, it is desirable they should be prepared immediately before use.

ELECTROLYTIC CONDUCTANCE OF TRIPHENYL PHOSPHORUS
DIHALIDES IN ACETONITRILE.

The solvent chosen for the conductance measurements was acetonitrile for the reasons given in Part I of the thesis, and in order to compare directly the behaviour of the triphenylphosphorus dihalides with the corresponding arsenic compounds in a polar solvent. Values of conductance at 25°C. are given in Table 23.

TABLE 23.

Electrolytic conductance of triphenyl phosphorus
dihalides in acetonitrile at 25°C.

Compound	C m mole litre ⁻¹	10 ⁴ κ ohm. ⁻¹ cm. ⁻¹	Λ_m ohm. ⁻¹ cm ² mole. ⁻¹
Ph ₃ PCl ₂	0.027	1.76 × 10	65.0
	0.040	2.20 "	55.0
	0.056	2.82 "	50.0
Ph ₃ PBr ₂	0.030	1.84 "	61.5
	0.042	2.37 "	56.5
	0.076	3.38 "	44.5
Ph ₃ PI _{1.5} Br _{0.5}	0.0087	6.06	70.0
	0.011	6.93	63.0
	0.016	9.27	58.0
Ph ₃ PI ₂	0.0054	4.78	88.5
	0.0069	5.05	73.0
	0.012	7.67	64.0

The conductance values clearly established the electrolytic behaviour of the dihalides in this solvent. The values decrease with increasing concentration over the range studied, but below 0.009 M the results for the dibromide and dichloride were not reproducible, perhaps due to traces of impurity in the solvent.

The conductance values of the dibromide and dichloride are considerably higher than their arsenic analogues, and this is in keeping with their structure in the solid state, which is thought to be ionic. The behaviour of these dihalides in acetonitrile, however, differs from that found in nitrobenzene by Issleib and Seidel (40). These authors reported that the conductance decreased with dilution, due to the formation of neutral molecules, but no conductance or concentration values were given.

For triphenyl phosphorus diiodide the results in acetonitrile parallel those in nitrobenzene, in so far as the conductance of the diiodide increases with dilution but the ions present in acetonitrile are not only those arising from the simple dissociation:

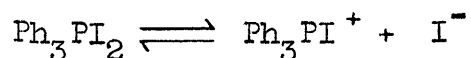

proposed by Issleib and Seidel. The ultraviolet spectrum of triphenylphosphorus diiodide in acetonitrile showed not only characteristic absorptions of the poly-

phenyl derivatives of pentavalent phosphorus at 262, 266 and 273 m μ (69), but also a weak characteristic absorption of the triiodide ion at 293 and 362 m μ . Therefore, some disproportionation must take place, presumably:

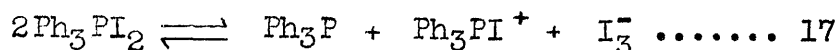

The ultraviolet spectrum of $\text{Ph}_3\text{PI}_{1.5}\text{Br}_{0.5}$ in acetonitrile was almost identical to the diiodide, with absorptions at 268 and 275 m μ , and at 293 and 362 m μ . Both the diiodide and $\text{Ph}_3\text{PI}_{1.5}\text{Br}_{0.5}$ had a peak at 247 m μ which has not been characterised.

The ultraviolet spectrum of the dibromide shows no evidence of trihalide formation, and thus does not disproportionate, and the same is probably true for the dichloride, since the trichloride ion is a rare species.

It has not been possible to determine ϵ values for the triiodide ions, and hence the extent of the disproportionation of the diiodide and $\text{Ph}_3\text{PI}_{1.5}\text{Br}_{0.5}$, since it appears that a photochemical decomposition occurs in ultraviolet light, the triiodide ion extinction coefficient decreasing to zero. The evidence of conductometric analyses however suggests that the disproportionation is much less than was found for triphenylarsenic diiodide and iodobromide.

ELECTROLYSES OF TRIPHENYL PHOSPHORUS DIHALIDES
IN ACETONITRILE.

Since Issleib and Seidel (40) have identified the chlorotriphenylphosphonium cation in solutions of the dichloride, then by analogy with the dihalides of triphenylarsine, the ionisation of the triphenylphosphorus dihalides is likely to comply with one of the following schemes:

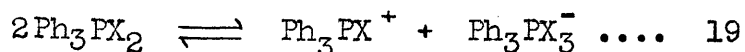
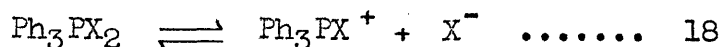

Provided there is no loss of products from solution via deposition on the electrodes or evolution as a gas, it should be possible to distinguish these schemes by noting the electrolyte changes occurring at the electrodes on electrolysis.

Using the same symbols as defined on page 25, the transport number (t^+)/ Δ Hal relationships will be as given in Tables 3 and 4 (pages 25 and 26).

Electrolysis of triphenylphosphorus dichloride in acetonitrile.

Acetonitrile solutions of triphenylphosphorus dichloride (ca. 0.05M) were electrolysed and, substituting the values of Δ Cl into Tables 3 and 4, the average transport numbers (t^+) obtained were :

scheme 18, $t^+ = 0.19$ and 0.17

scheme 19, $t^+ = 0.59$ and 0.55

Therefore, like its arsenic analogue, triphenylphosphorus dichloride ionises in acetonitrile by scheme 19, to form the hexasubstituted anion,

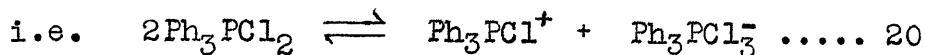

and it is suggested that the processes occurring at the electrodes are :-

at cathode:

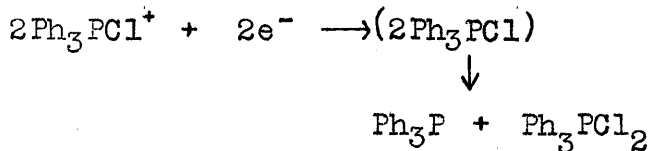

at anode:

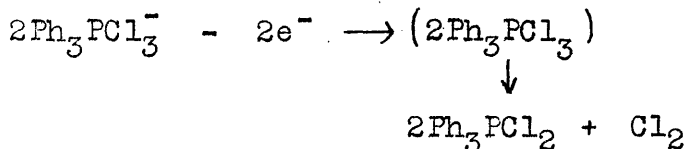

Electrolysis of triphenylphosphorus dibromide in acetonitrile.

Electrolysis of acetonitrile solutions of triphenylphosphorus dibromide in acetonitrile, like those of triphenyl arsenic dibromide, were accompanied by a yellow colouration in the originally colourless solution at the anode. Substituting the experimental values of ΔBr into Tables 3 and 4, the average transport number (t^+)

from scheme 18, was 0.48, and from scheme 19, 0.74.

Thus, the numerical value of the transport number strongly indicates that the ionic system must be described in terms of scheme 18. That is, triphenylphosphorus dibromide ionises in acetonitrile:

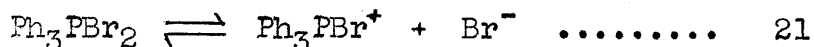

Thus, like the dichloride, the mode of ionisation parallels that of its arsenic analogue, and the non-formation of the tri-bromotriphenylphosphate (V) ion may be attributed to steric factors. The following electrode processes are suggested:

at cathode

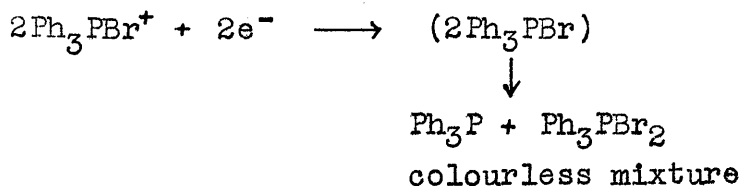

at anode

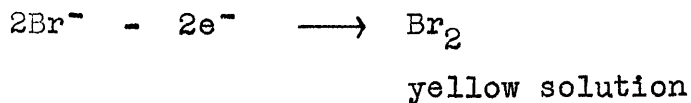

The disproportionation of the diiodide and $\text{Ph}_3\text{PI}_{1.5}\text{Br}_{0.5}$ to give the triiodide ion in addition to the ions from simple ionisation, complicates these systems and makes the interpretation of electrolysis experiments difficult. Therefore it has not been possible to determine the mode of ionisation of these dihalides in acetonitrile by this

method. However, it seems most likely from the trend shown by the dichloride and dibromide that the diiodide will ionise:

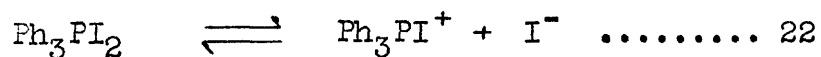

and this does receive some support from the conductometric titrations discussed in the next section. The obvious mode of ionisation of $\text{Ph}_3\text{PI}_{1.5}\text{Br}_{0.5}$, would then be:

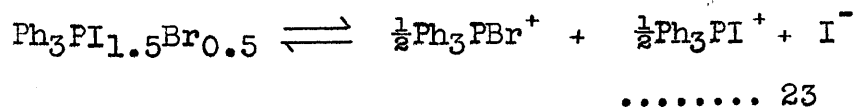

CONDUCTOMETRIC ANALYSES OF THE SYSTEMS
Hal₂ versus Ph₃P AND Hal₂ versus Ph₃PHal₂ in
ACETONITRILE (Hal = Br, I).

Since triphenylphosphorus dihalides form highly conducting solutions containing halide ions in acetonitrile, by analogy with the triphenylarsenic dihalides it would be expected that they should form tetrahalide adducts by the addition of a mole of halogen.

The existence of such tetrahalides was investigated conductometrically by examining the systems Hal₂ vs. Ph₃P and Hal₂ vs. Ph₃PHal₂ (Hal = Br, I), and the salient features of these systems are recorded in Table 24.

Nine experiments were carried out, and conductance-composition graphs of different shapes were found (fig.7). The stoichiometry of the reactions, deduced from the ratio at which conductance breaks occurred, combined with the conductance values and spectral data, constitutes strong evidence for the existence in solution of the dihalides Ph₃PI(2-n)Br_n, and of the tetrahalides Ph₃PI(4-n)Br_n. These compositions are analogous to the triphenylarsine-halogen adducts discussed in Part I.

A significant difference from the conductometric analyses involving triphenylarsine, however, is that in every case, triphenylphosphorus dihalides appear to be

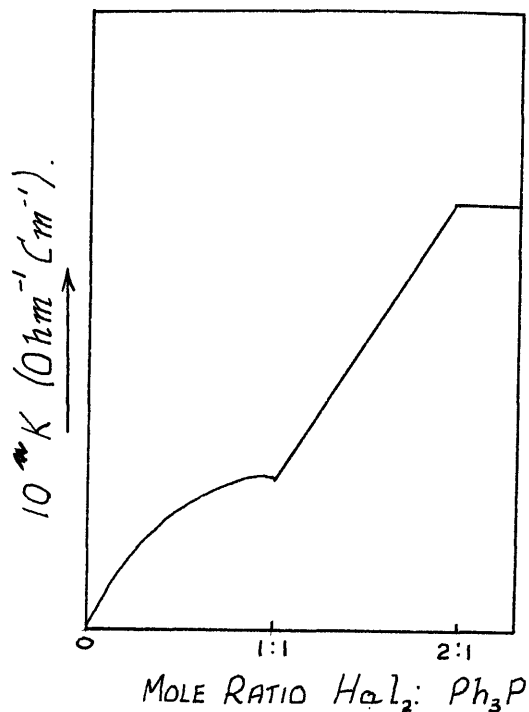

fig. 7 A.

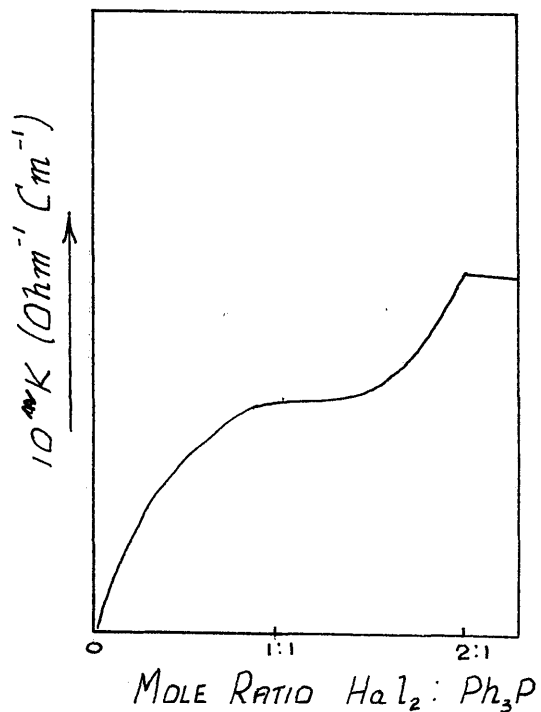

fig. 7 B.

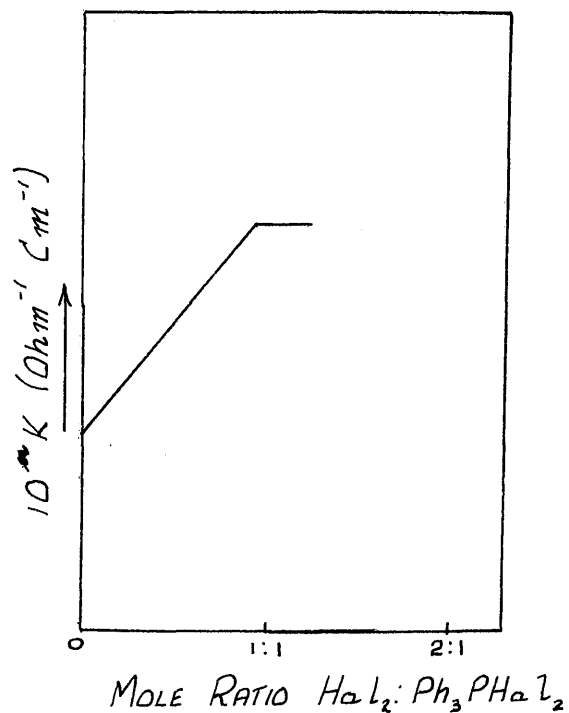

fig. 7C.

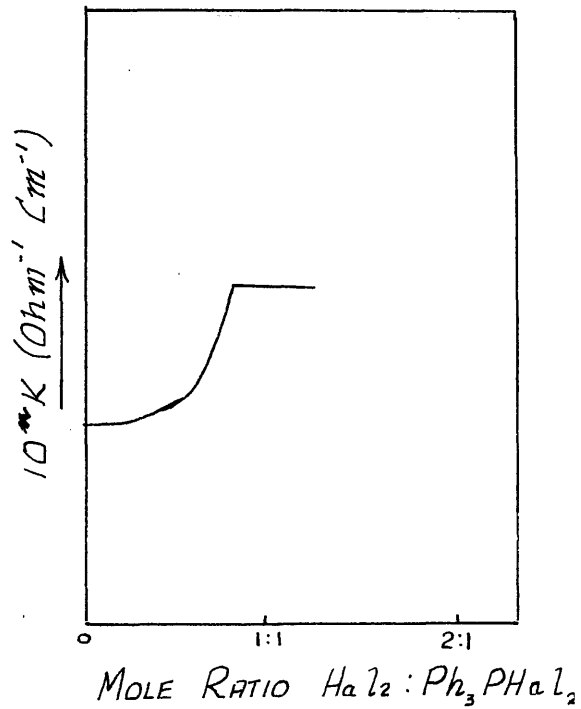

fig. 7 D.

fig. 7. Conductance-composition graphs in conductometric titrations of Hal_2 against Ph_3P , & Hal_2 against Ph_3PHal_2 .

TABLE 24. Conductometric analyses of Hal₂ against Ph₃P

Expt. No.	Reactants	Shape of graph fig.7	Ratio of conductance break.	Colour of solution before break.	Composition of species indicated.
1	I ₂ vs. Ph ₃ P	7 A	1 : 1	yellow	Ph ₃ P.I ₂
			2 : 1	red	Ph ₃ P.I ₄
2	IBr vs. Ph ₃ PI ₂	7 C	1 : 1	red	Ph ₃ PI ₂ .IBr
3	Br ₂ vs. Ph ₃ PI ₂	7 C	1 : 1	red	Ph ₃ PI ₂ .Br ₂
4	IBr vs. Ph ₃ P	7 A	1 : 1	yellow	Ph ₃ P.I Br
			2 : 1	red	Ph ₃ PIBr.IBr
5	I ₂ vs. Ph ₃ PIBr	7 C	1 : 1	red	Ph ₃ PIBr.I ₂
6	Br ₂ vs. Ph ₃ PIBr	7 C	1 : 1	orange	Ph ₃ PIBr.Br ₂
7	Br ₂ vs. Ph ₃ P	7 B	1 : 1	colourless	Ph ₃ P.Br ₂
			2 : 1	yellow	Ph ₃ P.Br ₄
8	I ₂ vs. Ph ₃ PBr ₂	7 D	1 : 1	red	Ph ₃ PBr ₂ .I ₂
9	IBr vs. Ph ₃ PBr ₂	7 D	1 : 1	orange	Ph ₃ PBr ₂ .IBr

and Hal₂ vs. Ph₃PHal₂ in acetonitrile.

Expt. No.	λ m at break	C m at break	U.V. absorption at break m. μ	U.V. indicates	Composition of compound isolated.
1	38	0.047	*291(w), 360(w)	I ₃ ⁻ (w)	Ph ₃ PI ₂
	96	0.036	*291, 360	I ₃ ⁻	Ph ₃ PI ₄
2	101	0.039	*291, 360	I ₃ ⁻	Ph ₃ PI ₃ Br
3	64	0.054	275, 351	I ₂ Br ⁻	
4	40	0.035	* -	-	Ph ₃ PI _{1.5} Br _{0.5}
	103	0.034	275, 351	I ₂ Br ⁻	Ph ₃ PI ₂ Br ₂
5	93	0.030	*291, 360	I ₃ ⁻	
6	103	0.030	257	IBr ₂ ⁻	Ph ₃ PIBr ₃
7			* -	-	Ph ₃ PBr ₂
	84	0.022	267, 273	Br ₃ ⁻	Ph ₃ PBr ₄
8	94	0.038	275, 351	I ₂ Br ⁻	Ph ₃ PI ₂ Br ₂
9	98	0.021	257	IBr ₂	Ph ₃ PIBr ₃

* In addition to the peaks shown, the characteristic absorptions of polyphenylphosphorus (V) compounds were observed at 262, 266 and 273 μ . (69). In the other systems, these were presumably masked by the more adjacent broad peaks of the other trihalide ions.

formed as stable entities in solution before tetrahalide formation commences. That is, without exception, the triphenylphosphorus dihalides may be considered to be intermediates in the formation of the triphenylphosphorus tetrahalides.

It is also interesting to note the absence of a break at $\text{Hal}_2 : \text{Ph}_3\text{P} = 1:2$ in experiments 1, 4 and 7 in Table 24. A break at this ratio might have been expected in support of Issleib and Seidel's view that the formation of tertiary phosphorus dihalides occurs through an intermediate of composition R_3PX ,

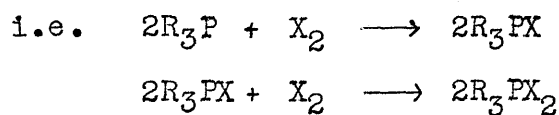

Ryden and Tonge have proved the existence of an intermediate stage in the formation of dihalides by addition of halogens to tertiary phosphites (70) and, independently, Harris and Payne made a similar suggestion on account of a break at $\text{Br}_2 : (\text{PhO})_3\text{P} = 1:2$, in the conductometric analysis of the reaction between bromine and triphenylphosphite in acetonitrile. The possible nature of Issleib and Seidel's intermediate is discussed in a later chapter.

The more important features of the individual experiments summarised in Table 24 are now discussed.

Experiment 1. Reaction of iodine with triphenylphosphine in acetonitrile.

This reaction, unlike the reaction of iodine with triphenylarsine, occurs in two stages. The weak triiodide absorption observed at the 1:1 ratio suggests the occurrence of the equilibrium

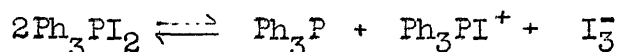

the products of which must contribute to the conductance at this point. However, the break at almost exactly the 1:1 ratio, coupled with the weakness of the triiodide absorption, indicates that the extent of the disproportionation is only slight, and the equilibrium lies well to the left hand side.

Since the presence of a strong triiodide absorption at the break at the 2:1 ratio is good confirmation for a tetraiodide, the reactions in solution giving fig.7 A must be :

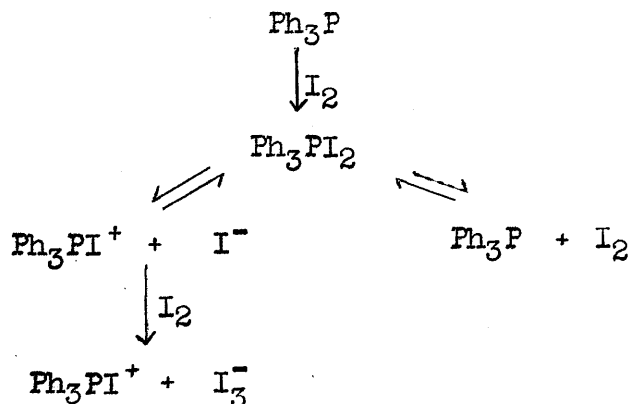

There is no evidence for an intermediate "Ph₃PI" in the preparation of the dihalide, and on mixing concentrated solutions of iodine and triphenylphosphine in the ratios 0.5:1 and 1:1, triphenylphosphorus diiodide precipitated in both cases. On mixing in a 2:1 ratio, triphenylphosphorus tetraiodide precipitated.

Experiments 2 and 3. Reaction of iodine bromide and bromine with triphenylphosphorus diiodide in acetonitrile.

In these experiments triphenylphosphorus diiodide was prepared in situ by adding iodine to triphenyl phosphine as far as the 1:1 ratio. The interesting feature of these reactions is that the formation of the tetrahalides must be accompanied by a very rapid halogen exchange between the cation and anion formed initially in each case. The change of slope when halogen was added to the diiodide solution again shows that the diiodide reacts predominantly as iodotriphenylphosphonium iodide.

For the addition of iodinebromide, assuming trihalide formation to occur by normal halogen-halide ion addition, the reaction in solution must initially be:

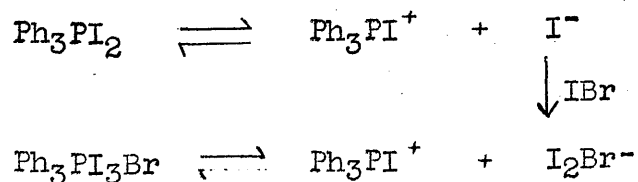

Since the only trihalide species observed in solution was the triiodide ion, however, the rearrangement

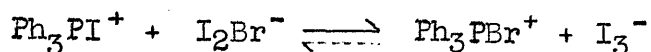

must occur. The driving force for this will be twofold since it involves formation of the more stable triiodide ion, and the phosphonium cation containing the more stable P - Hal bond.

Triphenylphosphorus triiodobromide was isolated by adding ether to a mixture of equimolar concentrated solutions of iodinebromide and triphenylphosphorus diiodide in acetonitrile. Thus, the tetrahalide indicated conductometrically and spectrophotometrically is in fact readily isolated, unlike the corresponding arsenic system, in which the tetraiodide precipitated on account of its low solubility.

In the reaction with bromine, the presence of the diiodobromide ion before the break at $\text{Br}_2 : \text{Ph}_3\text{PI}_2 = 1:1$ must also be due to a rearrangement of halogen atoms between the anion and cation.

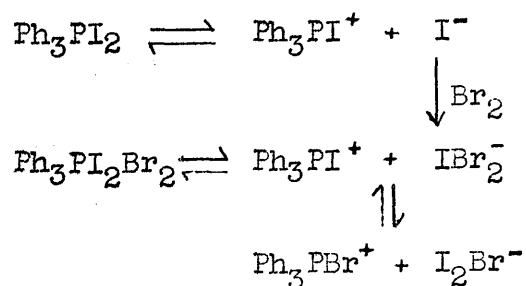

The conversion of the more stable to the less stable trihalide ion suggests that the mode of ionisation parallels that of its arsenic analogue, and is dependent on the nature of the cation.

Experiment 4. Reaction of iodinebromide with triphenyl phosphine in acetonitrile.

This system differs from the iodinebromide/triphenylarsine system, in that triphenylphosphorus iodobromide is indicated as a stable species in solution. The diiodobromide ion is present from the 1:1 up to the 2:1 ratio. After the 2:1 ratio, iodinebromide converts this to the dibromiodide ion, and at the 3:1 ratio conversion is complete. The ultra-violet spectrum and colour of the solution changed in the same way as indicated on page 47, for the arsenic system.

The reactions in solution can therefore be written

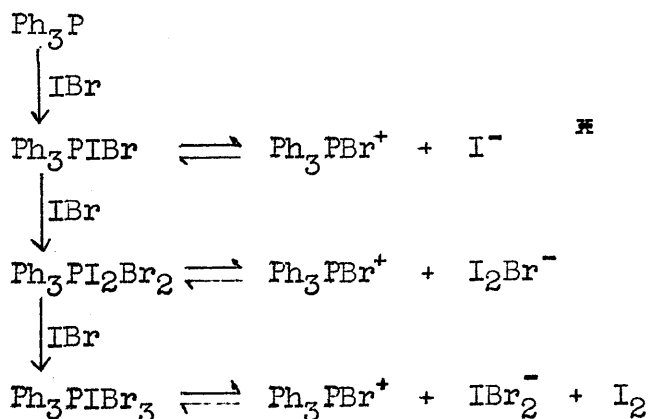

* The formulation of the ionisation of the iodobromide as

$(\text{Ph}_3\text{PBr})^+ \text{I}^-$ and not $(\text{Ph}_3\text{PI})^+ \text{Br}^-$ was suggested by the stronger P-Hal bond in the bromotriphenylphosphonium cation.

Solid products were isolated by mixing concentrated acetonitrile solutions of iodinebromide and triphenylphosphine in the mole ratios 1:1, 2:1 and 3:1. The dihalide isolated at the 1:1 ratio was not triphenylphosphorus iodobromide, but had in fact the unexpected composition $\text{Ph}_3\text{PI}_{1.5}\text{Br}_{0.5}$, which is an entirely novel stoichiometry for a tertiary Group Vb dihalide. This unusual stoichiometry must be related to the crystal structure, about which little can be said in the absence of an X-ray structural analysis. The electrolytic behaviour of this dihalide has been mentioned earlier. A somewhat similar situation has been found by Zingaro and Meyers, who established the existence of $\text{Ph}_3\text{PS}\cdot\text{I}_2$ in solution, yet isolated a solid of composition $2 \text{Ph}_3\text{PS}\cdot 3\text{I}_2$ (48). Therefore once again it has been aptly demonstrated that the composition of a compound which crystallises from solution at a stoichiometric mole ratio need not reflect the composition of the solution.

Yet it seems certain that triphenylphosphorus iodobromide must exist in solution, to account for the nature of the graph and the formation of triphenylphosphorus diiododibromide by the addition of another mole of iodinebromide. Unlike its arsenic analogue, triphenylphosphorus diiododibromide

is very unstable, and decomposed in the drybox within a few hours of filtration. Triphenylphosphorus iodotribromide was isolated at the 3:1 ratio and it too was very unstable. The instability of these adducts is discussed in a later chapter.

Experiments 5 and 6. Reaction of iodine and bromine with triphenylphosphorus iodobromide in acetonitrile.

The data given in Table 24 for the respective additions of iodine and bromine to a solution of composition $\text{Ph}_3\text{P} \cdot \text{I} \cdot \text{Br}$ further confirm the existence in solution of triphenylphosphorus iodobromide as a stable entity. The breaks, conductance values and solution colours are further evidence for the formation of triphenylphosphorus triiodobromide and triphenylphosphorus iodotribromide in solution, and the spectral data confirm their modes of ionisation as deduced from experiments 2 and 4.

The solution reactions are, as expected:

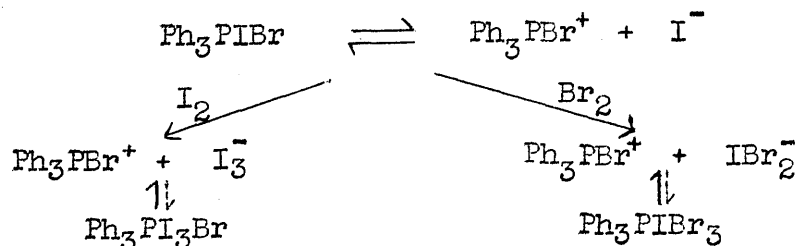

Experiment 7. Reaction of bromine with triphenylphosphine in acetonitrile.

Again in this reaction there is no break in conductance below the 1:1 mole ratio, which would have indicated an intermediate "Ph₃PBr" in the formation of the dihalide, and Table 24 shows that the reaction of bromine with triphenyl phosphine occurs in two stages. Firstly, bromotriphenylphosphonium bromide (transport experiments) is formed, which must add bromine by the normal halogen/halide ion addition to form bromotriphenylphosphonium tribromide.

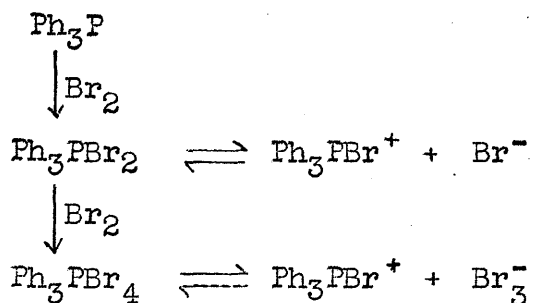

The reason for the splitting of the tribromide peak in the ultraviolet spectrum from 269 m μ to 267 and 273 m μ is not known. A similar effect has also been found in bis (diphenylphosphine) methylamine hexabromide (71), presumably $\{\text{Ph}_2\text{P}^+(\text{Br})\text{N}(\text{Me})\text{P}^+(\text{Br})\text{Ph}_2\} \text{Br}^-\text{Br}_3^-$. (cf. $2(\text{Me}_3\text{NH})^+ \text{Br}^- \text{Br}_3^-$) (72).

Triphenylphosphorus dibromide precipitated on mixing concentrated equimolar solutions of bromine and triphenylphosphine, and triphenylphosphorus tetrabromide was isolated by ether precipitation from a solution containing bromine and triphenylphosphine in a 2:1 ratio.

Experiments 8 and 9. Reaction of iodine and iodine bromide with triphenylphosphorus dibromide in acetonitrile.

The reaction of iodine and iodinebromide with triphenyl phosphorus dibromide followed the normal course of halogen/halide ion addition, to form triphenylphosphorus diiododibromide and triphenylphosphorus iodotribromide respectively at the 1:1 ratios.

The reactions in solution may be represented

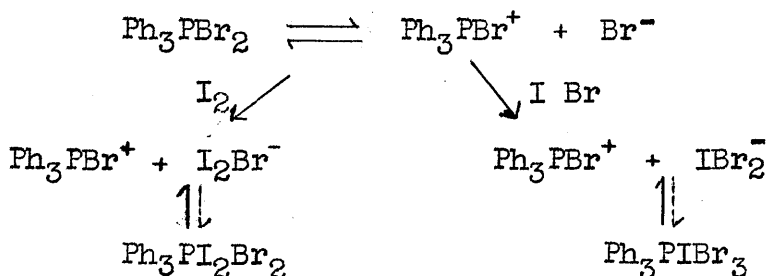

A tetrahalide series has therefore been prepared as predicted by adding two moles of halogen to a tertiary phosphine. It is interesting to note that in spite of the many preparations of tertiary phosphorus dihalides by direct halogen addition, only two examples of this type of compound - tricyclohexylphosphorus tetrabromide and tetraiodide - have been reported (40).

ELECTROLYTIC CONDUCTANCE OF TRIPHENYLPHOSPHORUS

TETRAHALIDES IN ACETONITRILE.

The electrolytic conductance of the triphenylphosphorus tetrahalides was determined on freshly prepared samples.

Values are given in Table 25.

TABLE 25.

Electrolytic conductance of triphenylphosphorus tetrahalides in acetonitrile at 25°C.

Compound	cm.	$10^3 \kappa$	Λ_m
Ph ₃ PI ₄	0.0086	1.15	133
	0.014	1.67	119
	0.017	1.76	103
Ph ₃ PI ₃ Br	0.0076	0.85	112
	0.013	1.34	103
	0.025	2.10	84.0
Ph ₃ PI ₂ Br ₂	0.006	0.72	120
	0.010	1.04	104
	0.021	1.85	89
Ph ₃ PIBr ₃	0.0031	0.37	119
	0.013	1.39	107
	0.022	1.81	82.5
Ph ₃ PBr ₄	0.012	1.32	110
	0.020	2.04	102
	0.033	2.91	89

The conductance values show that the triphenylphosphorus tetrahalides behave as strong electrolytes in acetonitrile, and for each compound the molar conductance values decrease with increasing concentration, and over the concentration range studied (0.003 - 0.04 M) bear a linear relationship to the square root of the concentration.

Not only do the conductance values of the triphenylphosphorus tetrahalides parallel those of the triphenylarsenic series, but also the modes of ionisation are similar. The ultraviolet spectra of conductance solutions showed unambiguously that the anions indicated for the tetrahalides in Table 24 are exactly those found when the solid tetrahalides are dissolved in acetonitrile. These U.V. maxima are given in Table 26, along with the colour and melting points of the compounds. (See also Appendix 4 for infrared spectra.)

TABLE 26. Triphenylphosphorus tetrahalides.

Compound	Colour	m.p.	U.V. (m μ)	ϵ	Mode of Ionisation
Ph_3PI_4	purple	132°	291 361	60,120 30,400	$\text{Ph}_3\text{PI}^+ \text{I}_3^-$
$\text{Ph}_3\text{PI}_3\text{Br}$	purple-red	127°	291 361	54,600 21,200	$\text{Ph}_3\text{PBr}^+ \text{I}_3^-$
$\text{Ph}_3\text{PI}_2\text{Br}_2$	red	79°	273 351	45,700 9,000	$\text{Ph}_3\text{PBr}^+ \text{I}_2\text{Br}^-$
Ph_3PIBr_3	orange	101°	257	53,900	$\text{Ph}_3\text{PBr}^+ \text{IBr}_2^-$
Ph_3PBr_4	orange	117°	267 272	57,300 57,300	$\text{Ph}_3\text{PBr}^+ \text{Br}_3^-$

That is, the mode of ionisation of each triphenylphosphorus tetrahalide, exactly parallels its triphenylarsenic analogue, and the critical mode of ionisation of the diiododibromide to form the less stable trihalide ion shows that the greater stability of the bromotriphenylphosphonium cation over the iodotriphenylphosphonium cation controls the ionisation of the series. This also explains the halogen migration found in experiments 2 and 3, Table 24.

The nature of the triphenylphosphorus tetrahalides
in the solid state.

Although the triphenylphosphorus tetrahalides behave in solution exactly as the triphenylarsenic tetrahalides, they are much less stable in the solid state, and readily dissociate to dihalide plus halogen. This tendency to dissociate made characterisation of these compounds difficult, for with the exception of the tetraiodide, analyses of the compounds at first showed a deficiency of halogen. Their handling is also complicated by a strong susceptibility to hydrolysis by moist air.

The diiododibromide is isolated as red translucent needles but these decompose within hours of filtration even in an inert atmosphere in a drybox. They may be stored up to several days under anhydrous ether but finally decompose to a purple oil. Analyses have confirmed that the solid decomposition product is $\text{Ph}_3\text{PI}_{1.5}\text{Br}_{0.5}$.

The decomposition of the iodotribromide is also rapid and it has been impossible to obtain accurate analytical figures for the compound unless the analyses were carried out immediately after its isolation. After standing for several days, analyses (by Bernhardt in Germany) indicated the composition $\text{Ph}_3\text{PI}_{0.67}\text{Br}_{1.33}$. That is, triphenylphosphorus iodotribromide dissociates to form another dihalide of novel stoichiometry, whose formation presumably must again be related to crystal structure effects.

Triphenylphosphorus tetrabromide readily loses a mole of bromine to form the dibromide, but the dissociation product of the triiodobromide had a non-stoichiometric composition ($\text{Ph}_3\text{PI}_{2.7}$).

The instability of these compounds therefore makes their structural analysis rather difficult and even the tetraiodide - which appears least prone to dissociation - decomposed in the X-ray beam.

The resultant decrease in stability on replacing the arsonium ion by the smaller phosphonium ion closely follows the stability trends in other trihalide compounds containing the same anion but different cations, in which the stability in each case increased with the increasing size and symmetry of the cation (52). Therefore, since the halotriphenyl-

phosphonium ions are presumably of the same symmetry as the halotriphenylarsonium ions, but are of a lesser size, the stability trend of the tetrahalides is exactly what would be predicted in terms of the behaviour of other compounds containing trihalide ions.

REACTION OF THE HALOGENS WITH TRIPHENYLPHOSPHINE
IN MOIST ACETONITRILE.

The importance of using thoroughly dried solvent in the addition of halogen to triphenylphosphine in acetonitrile was well illustrated when either iodine, iodinebromide or bromine were added to triphenylphosphine in moist acetonitrile.

In each case, the course of the reaction differed from that in pure solvent, in that monohalides of triphenylphosphine were isolated. The relative yields of dihalide and monohalide were dependent on the amount of water in the solvent, and if sufficient was present, no dihalide was formed.

The monohalides are in fact triphenylphosphonium salts, and were identified as such by their infra-red spectra, which have a band at $\sim 2,200 \text{ cm.}^{-1}$ corresponding to the P - H stretching frequency. The spectra of such compounds have been discussed by Sheldon and Tyree (73). (See Appendix 4.)

The products isolated from each reaction are summarized in Table 27. Triphenylphosphonium iodide is a well defined compound and was prepared by Michaelis in 1885 (66). The stoichiometry of $\text{Ph}_3\text{PH}^+(\text{I}_{0.33}\text{Br}_{0.67})^-$ is entirely novel in such a compound, and as in the dihalide $\text{Ph}_3\text{PI}_{1.5}\text{Br}_{0.5}$

TABLE 27. Products from Ph₃P + X₂ (X = I, Br.)
in moist acetonitrile.

Halogen	Dihalide	Triphenyl- phosphonium monohalide	Colour	m.p.
I ₂	Ph ₃ PI ₂	Ph ₃ PH.I	white	207°
IBr	Ph ₃ PI _{1.5} Br _{0.5}	Ph ₃ PH.I _{0.33} Br _{0.67}	white	205°
Br ₂	Ph ₃ PBr ₂	Ph ₃ PH.Br	white	163°

(produced by iodinebromide addition to triphenylphosphine in anhydrous acetonitrile) is assumed to be due to crystal lattice effects. Triphenylphosphonium bromide had not previously been well characterised (73) (74), although an alternative preparation has been reported at the time of writing this thesis.

To investigate the existence of triphenylphosphonium triiodide, equimolar solutions of iodine and triphenylphosphonium iodide in dry acetonitrile were mixed. The reaction, however, produced triphenylphosphorus diiodide and hydrogen iodide only.

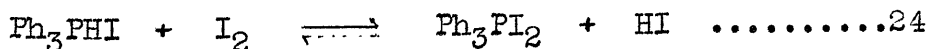

This reaction is of interest for two reasons. Firstly, it clearly has some potential as a new synthetic route to dihalides, and secondly it assumes significance when

considering Issleib and Seidel's claim to have isolated monohalide intermediates in the preparation of triphenylphosphorus dihalides. These authors have recorded that such intermediates had the form R_3PX , and were differentiated from the dihalides by "their insolubility in organic solvents, melting points, conductivities, and in the case of the iodine compounds, by their colour", but the compounds have received no further mention in subsequent publications.

The differences in properties of the monohalides and dihalides mentioned by Issleib and Seidel (who gave no supporting experimental data) are those to be expected between, say, triphenylphosphonium iodide (white solid, m.p. 207° , $\Lambda_m = 120 \text{ ohm}^{-1} \text{ cm}^2 \text{ mole}^{-1}$ at $cm = 0.012$) and triphenylphosphorus diiodide (yellow solid, m.p. 172° , $\Lambda_m = 64 \text{ ohm}^{-1} \text{ cm}^2 \text{ mole}^{-1}$ at $cm = 0.011$). Further, the analytical figures of $Ph_3P^+I^-$ and a compound Ph_3PI , are too close to be accurately distinguishable, and equation 24 shows that triphenylphosphonium iodide can, under certain circumstances, behave as an intermediate in the formation of the diiodide.

Therefore, it can be claimed with a fair degree of certainty that Issleib and Seidel's intermediates are in fact tertiary phosphonium halides produced by traces of water in the solvent.

Thus, in contradiction to Issleib and Seidel, it is suggested that triphenylphosphorus dihalides are formed directly by halogen addition to triphenylphosphine, if the solvent is free from moisture. If this is not so, the halogen reacts firstly with the water, and the products of this reaction add to triphenylphosphine, producing Ph_3PHX and perhaps Ph_3PHOX .

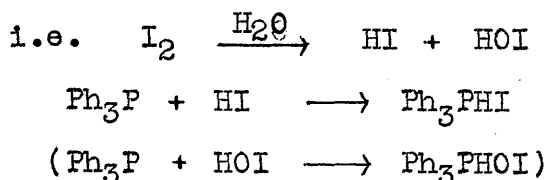

Only when all of the water has reacted with the iodine will the dihalide be formed either by reaction 24, or directly.

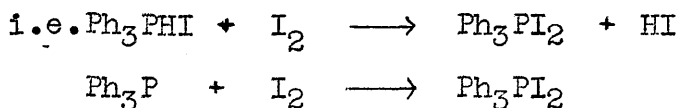

The mode of halogen addition to triphenylphosphine in moist acetonitrile is a good illustration of the statement:

"A number of reactions of phosphorus derivatives are apparently catalysed or modified by traces of moisture; the entire course of such reactions may be significantly altered unless moisture is rigorously excluded."

SUMMARY:

The triphenylphosphorus dihalides studied, dissolve in acetonitrile to form highly conducting solutions. Values of molar conductance indicate that triphenylphosphorus dichloride and dibromide are stronger electrolytes in acetonitrile than their arsenic analogues, but their modes of ionisation are parallel.

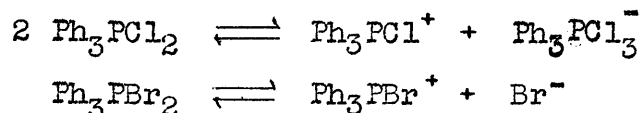

The existence of triphenylphosphorus iodobromide was indicated in solution, but it could not be isolated as a solid. Instead, a dihalide of novel stoichiometry, $\text{Ph}_3\text{PI}_{1.5}\text{Br}_{0.5}$, was obtained. Both $\text{Ph}_3\text{PI}_{1.5}\text{Br}_{0.5}$ and triphenylphosphorus diiodide form conducting solutions in acetonitrile. The triiodide ion is present in these solutions, which indicates that these dihalides must disproportionate to some extent.

A series of tetrahalides $\text{Ph}_3\text{PI}_{(4-n)}\text{Br}_n$ has been indicated conductometrically, and each member subsequently prepared by halogen addition to triphenylphosphine, the dihalides being intermediates in each case. The tetrahalides behave as halotriphenylphosphonium trihalides in acetonitrile, and their mode of ionisation parallels that

of the $\text{Ph}_3\text{AsI}(4-n)\text{Br}_n$ series. That is, ionisation occurs to give the Ph_3PBr^+ cation rather than the Ph_3PI^+ ion, and is not affected by trihalide ion stabilities. In the solid state, the tetrahalides are much less stable than the arsenic compounds, and readily decompose to dihalide and halogen. This instability is attributed to the smaller cation, and is in keeping with the behaviour of other series of ionic trihalide compounds. Triphenylphosphorus iodotribromide decomposes to another dihalide of novel stoichiometry, $\text{Ph}_3\text{PI}_{0.67}\text{Br}_{1.33}$.

In moist acetonitrile, the course of halogen addition to triphenylphosphine is altered, and triphenylphosphonium salts are isolated. These have the composition $\text{Ph}_3\text{PH}^+ \text{I}^-$, $\text{Ph}_3\text{PH}^+ (\text{I}_{0.33}\text{Br}_{0.67})^-$, and $\text{Ph}_3\text{PH}^+ \text{Br}^-$. It is suggested that such compounds are the "monohalide adducts" (R_3PX) reported by Issleib and Seidel as being possible intermediates in the formation of triphenylphosphorus dihalides.

EXPERIMENTAL PART.

PREPARATION OF TRIPHENYLPHOSPHORUS - HALOGEN ADDUCTS.

(i) TRIPHENYLPHOSPHORUS DIHALIDES.

Preparation of triphenylphosphorus dichloride.

A stream of dry chlorine in nitrogen was bubbled into a solution of triphenylphosphine in anhydrous petroleum ether at -80° . White crystals of the dichloride precipitated, and the solution became green due to the presence of free chlorine. The hygroscopic crystals were filtered in the drybox, washed with anhydrous ether, and dried in vacuo. They were used immediately.

Preparation of triphenylphosphorus dibromide.

Bromine (1.072 g. 0.00670 mole) dissolved in acetonitrile (15 ml.) was added to triphenylphosphine (2.560 g. 0.00670 mole) suspended in acetonitrile (40 ml.). Heat was evolved, the triphenylphosphine dissolved, and the solution remained colourless. White crystals precipitated, and a further crop was obtained by the addition of anhydrous ether (60 ml.). The crystals were filtered in the drybox, washed with anhydrous ether, and dried in vacuo. (Found: Br, 37.7. Calc. for $C_{18}H_{15}Br_2P$; Br, 37.9%).

Preparation of $\text{Ph}_3\text{PI}_{1.5}\text{Br}_{0.5}$.

Iodine bromide (0.0147 mole) in acetonitrile (20 ml.) was added to a suspension of triphenylphosphine (3.842 g. 0.0147 mole) in acetonitrile (40 ml.). Heat was evolved, the triphenylphosphine dissolved, and the solution became yellow. Yellow crystals precipitated. These were filtered in the drybox, washed with anhydrous ether and dried in vacuo, m.p. 244-5°. (Found: C, 43.8; H, 3.1; Br, 8.6; I, 38.4; P, 6.0. $\text{C}_{18}\text{H}_{15}\text{Br}_{0.5}\text{I}_{1.5}\text{P}$ requires C, 43.7; H, 3.1; Br, 8.3; I, 38.7; P, 6.3%.)

Preparation of triphenylphosphorus diiodide.

Iodine (1.733 g. 0.00683 mole) dissolved in acetonitrile (50 ml.) was added to triphenylphosphine (1.789 g., 0.00683 mole) suspended in acetonitrile (30 ml.). The solution became yellow, heat was evolved, and the triphenylphosphine dissolved. Yellow crystals precipitated, which were filtered in the drybox, washed with anhydrous ether, and dried in vacuo, m.p. 173-4°. (Found: C, 41.7; H, 3.1; I, 49.0; P, 5.9. Calc. for $\text{C}_{18}\text{H}_{15}\text{I}_2\text{P}$: C, 41.9; H, 2.9; I, 49.2; P, 6.0%; m.p. 148° (40)).

(2) PREPARATION OF TRIPHENYL-PHOSPHORUS TETRAHALIDES.

Preparation of triphenylphosphorus tetraiodide.

Iodine (4.594 g., 0.0181 mole) dissolved in acetonitrile (60 ml.) was added slowly to triphenylphosphine

(2.374 g., 0.00905 mole) suspended in acetonitrile (20 ml.) The solution firstly became yellow, heat was evolved, and yellow crystals of triphenylphosphorus diiodide precipitated. As addition of the iodine solution continued, the diiodide crystals dissolved and the solution became red. After being kept for a few moments at room temperature, purple needles precipitated and were filtered in the drybox, washed with anhydrous ether, and dried in vacuo, m.p. 132°C. (Found: C,28.4; H,2.2; I,65.7; P,4.1. $C_{18}H_{15}I_4P$ requires C,28.1; H,2.0; I,66.0; P,4.0%.)

Preparation of triphenylphosphorus triiodobromide.

Iodine (3.957 g., 0.0156 mole) dissolved in acetonitrile (50 ml.) was added to triphenylphosphine (4.087 g., 0.0156 mole) suspended in acetonitrile (30 ml.) The solution became yellow, and triphenylphosphorus diiodide precipitated.

Iodinebromide (0.0156 mole) dissolved in acetonitrile (30 ml.) was added to the suspension of triphenylphosphorus diiodide (0.0156 mole) in acetonitrile. The precipitated dihalide dissolved and the solution became red. On the addition of anhydrous ether (400 ml.), red crystals precipitated which were filtered in the drybox, & washed with

anhydrous ether, which was removed under slightly reduced pressure, m.p. 127°C. (Found: C,29.9; H,2.0; Br,10.9; I,52.9; P,4.2. $C_{18}H_{15}BrI_3P$ requires C,29.9; H,2.1; Br,11.1; I,52.7; P,4.3%.)

Preparation of triphenylphosphorus diiododibromide.

Iodinebromide (0.0162 mole) dissolved in acetonitrile (20 ml.) was added slowly to triphenylphosphine (2.121 g., 0.0162 mole) suspended in acetonitrile (25 ml.). The solution initially became yellow, and the yellow dihalide $Ph_3PI_{1.5}Br_{0.5}$ precipitated, but redissolved as addition of iodinebromide continued. Anhydrous ether (200 ml.) was added to the finally clear red solution and after being kept overnight at ca. -5°C. long translucent red needles crystallised. These were filtered in the drybox and washed with anhydrous ether, which was removed under slightly reduced pressure, m.p. 79°C. (Found: C,32.4; H,2.4; Br, 22.8; I,37.8; P,4.6. $C_{18}H_{15}Br_2I_2P_2$ requires C,32.0; H,2.2; Br,23.6; I,37.6; P,4.6%.)

The diiododibromide is not stable in the solid state after filtration and decomposes in a matter of hours even in a nitrogen-filled drybox. It may be stored under anhydrous ether for several weeks, but finally decomposes to a red oil.

A possible clue to the mode of dissociation was found in the first analysis of the compound: (Found: C,42.1; H,3.1; Br,8.2; I,40.0; P,6.5. $C_{18}H_{15}Br_{0.5}I_{1.5}P$ requires C,43.7; H,3.1; Br,8.3; I,38.7; P,6.3%), which gave the composition $Ph_3PI_{1.5}Br_{0.5}$, and suggested that the decomposition was the loss of a mole of halogen to form a dihalide. For this reason, solvent is removed from the crystals by slightly reduced pressure only, to avoid pumping off halogen.

The method of isolation of triphenylphosphorus diiododibromide by the addition of iodine dissolved in acetonitrile to an equimolar solution of triphenylphosphorus dibromide in acetonitrile is similar to that described above.

Preparation of triphenylphosphorus iodotribromide.

Bromine (1.081 g., 0.00676 mole) dissolved in acetonitrile (20 ml.) was added to triphenylphosphine (1.773 g., 0.00676 mole) suspended in acetonitrile (30 ml.). Heat was evolved, and white crystals of triphenylphosphorus dibromide precipitated. Iodine bromide (0.00676 mole) dissolved in acetonitrile (15 ml.) was added to the triphenylphosphorus dibromide (0.00676 mole), which dissolved and the solution became orange. Anhydrous ether (250 ml.) was added to the acetonitrile solution and orange crystals precipitated. They were filtered in the drybox, washed

with anhydrous ether, and dried under slightly reduced pressure, m.p. 101°C. (Found: Br, 37.9; I, 20.2.

$C_{18}H_{15}Br_3IP$ requires Br, 38.1; I, 20.2%.)

Triphenylphosphorus iodotribromide is hydrolytically unstable and also readily loses a mole of halogen on standing to form a dihalide of novel stoichiometry.

(Found: C, 47.2; H, 3.5; Br, 23.4; I, 18.5; P, 7.3.

$C_{18}H_{15}Br_{1.33}I_{0.67}P$ requires C, 47.7; H, 3.3; Br, 23.5;

I, 18.6; P, 6.8%.) The analysis given, therefore, shows unambiguously that the dihalide $Ph_3PI_{0.67}Br_{1.33}$ is formed by loss of a mole of halogen from Ph_3PIBr_3 .

The iodotribromide may also be isolated as described above, by the addition of three moles of iodinebromide in acetonitrile to a solution in acetonitrile of triphenylphosphine.

In every case, however, analysis by Bernhardt (Mulheim, Germany) gave the composition $Ph_3PI_{0.67}Br_{1.33}$ and the composition Ph_3PIBr_3 was only established by a mixed halogen analysis performed immediately after isolation of the compound.

Preparation of triphenylphosphorus tetrabromide.

Bromine (2.235 g., 0.0140 mole) dissolved in acetonitrile (20 ml.) was added to triphenylphosphine (1.834 g., 0.070 mole) suspended in acetonitrile (20 ml.). Heat was

evolved, and triphenylphosphorus dibromide precipitated, but subsequently dissolved, such that a clear orange solution remained. The addition of anhydrous ether (150 ml.) precipitated orange crystals, which were filtered in the drybox, washed with anhydrous ether, and dried under slightly reduced pressure, m.p. 117°C. (Found: C, 37.4; H, 2.7; Br, 54.9; P, 5.5. $C_{18}H_{15}Br_4P$ requires C, 37.2; H, 2.6; Br, 54.9; P, 5.3%.)

This tetrahalide is hydrolytically unstable, and readily loses a mole of halogen to form triphenylphosphorus dibromide.

3) TRIPHENYLPHOSPHONIUM HALIDES.

Triphenylphosphonium Iodide.

Iodine (1.129 g., 0.00354 mole) dissolved in acetonitrile (20 ml.) was added slowly, with constant swirling, to triphenylphosphine (0.928 g., 0.00354 mole) dissolved in acetonitrile (30 ml.) and water (0.2 ml.). The solution remained colourless throughout almost the entire addition, and the addition of ether (60 ml.) precipitated white needles. These were filtered in the drybox, washed with anhydrous ether, and dried in vacuo, m.p. 207°. (Found: C, 55.3; H, 3.9; I, 32.5; P, 8.2. Calc. for $C_{18}H_{16}IP$; C, 55.6; H, 3.9; I, 32.7; P, 7.9%; m.p. 217°).

Ph₃PH. I_{0.33}Br_{0.67}

Iodinebromide (0.00662 mole) dissolved in acetonitrile (10 ml.) was added slowly, with constant swirling, to triphenylphosphine (1.735 g. 0.00662 mole) dissolved in acetonitrile (50 ml.) and water (0.2 ml.). The solution remained colourless throughout the addition, and anhydrous ether (200 ml.) was added. White crystals precipitated, m.p. 207°. (Found: C,59.1; H,4.8; Br,15.4; I,12.0; P,8.6. C₁₈H₁₆Br_{0.67}I_{0.33}P requires C,59.9; H,4.5; Br,14.8; I,11.8; P,8.6%.)

Triphenylphosphonium bromide.

Bromine (2.07 g. 0.0129 mole) dissolved in acetonitrile (15 ml.) was added to triphenylphosphine (3.389 g. 0.0129 mole) suspended in acetonitrile (40 ml.) and water (0.2 ml.). The solution remained colourless throughout the addition, the triphenylphosphine dissolved, and some triphenylphosphorus dibromide precipitated. The flask was left overnight at 0°C. to ensure quantitative precipitation of the dihalide. The dihalide was filtered in the drybox, and anhydrous ether (80 ml.) added to the filtrate. White crystals precipitated, which were washed with ether, filtered and dried in vacuo, m.p. 163°. (Found: C,62.9; H,4.9; Br,23.3; P,8.9. C₁₈H₁₆BrP requires C,62.7; H,4.7; Br,23.3; P,9.1%.)

4) OTHER PREPARATIONS.

Triphenylphosphorus diiodide in reaction 24.

Iodine (0.722 g., 0.00285 mole) dissolved in acetonitrile (20 ml.) was added to triphenylphosphonium iodide (1.110 g., 0.00285 mole) suspended in acetonitrile (20 ml.). The triphenylphosphonium iodide dissolved, and the solution became red. On standing, yellow crystals precipitated, which were filtered in the drybox, washed with anhydrous ether and dried in vacuo, m.p. 172°. (Found: I, 49.0. Calc. for $C_{18}H_{15}I_2P$: I, 49.2%. m.p. 173-4°.) Also, the I.R. spectrum of the yellow compound was identical to that of triphenylphosphorus diiodide.

Red solid from triphenylphosphorus diiodide.

On standing triphenylphosphorus diiodide under anhydrous ether, red crystals began to form among the yellow dihalide crystals. After several weeks, the conversion to the red solid appeared complete. The red solid was filtered in the drybox, washed with anhydrous ether, and dried in vacuo, m.p. 111°. (Found: C, 45.0; H, 3.0; I, 40.5; P, 10.0. $C_{12}H_{10}IP$ requires C, 46.2; H, 4.0; I, 40.7; P, 10.0%.)

When dissolved in acetonitrile, the compound gave a conducting solution containing the triiodide ion, with a halogen ratio of anion:cation = 3:1 (transport experiments, $t^+ = 0.5$).

PURIFICATION OF MATERIALS:

The purification of acetonitrile, chlorine, bromine, iodinebromide, iodine and ether have been described in part 1 of the thesis.

Triphenylphosphine.

The triphenylphosphine of B.D.H.Ltd. was recrystallised from 95% ethanol until constant melting-point was obtained. m.p.79°.

Triphenylphosphorus dihalides and tetrahalides.

The triphenylphosphorus halogen adducts were purified as described for their arsenic analogues in Part 1.

CONDUCTANCE MEASUREMENTS.

These were carried out in a dipping electrode cell, as described in Part 1. The compounds were used within minutes of filtration in the drybox.

ELECTROLYSIS EXPERIMENTS.

These were carried out as described in Part 1, and Appendix 3.

CONDUCTOMETRIC TITRATIONS.

Conductometric titrations were carried out as described in Appendix 2. At all times, halogen was used as titrant, and the dihalides were prepared in situ by mixing equimolar

solutions of halogen and triphenylphosphine. The experiments were deemed invalid if a solid phase separated at any stage.

The results for the experiments 1 - 9, in Table 24, are given below:-

(1) Iodine vs. triphenylphosphine.

<u>Mole ratio</u> I ₂ : Ph ₃ P	<u>10³ K</u> ohm. ⁻¹ cm. ⁻¹	<u>Mole ratio</u> I ₂ : Ph ₃ P	<u>10³ K</u> ohm. ⁻¹ cm. ⁻¹
0	0.001	1.56	2.76
0.29	1.34	1.70	2.98
0.50	1.57	1.83	3.23
0.71	1.67	1.98	3.47
0.99	1.81	2.26	3.54
1.27	2.25	2.54	3.54

(2) Iodinebromide vs. triphenylphosphorus diiodide.

<u>Mole ratio</u> IBr : Ph ₃ PI ₂	<u>10³ K</u> ohm. ⁻¹ cm. ⁻¹	<u>Mole ratio</u> IBr : Ph ₃ PI ₂	<u>10³ K</u> ohm. ⁻¹ cm. ⁻¹
0	2.10	0.96	3.63
0.19	2.50	1.15	3.87
0.38	2.69	1.34	3.73
0.58	2.96	1.54	3.13
0.77	3.15	1.73	3.66

(3) Bromine vs. triphenylphosphorus diiodide.

<u>Mole ratio</u> Br ₂ : Ph ₃ PI ₂	<u>10³ κ</u> ohm. ⁻¹ cm. ⁻¹	<u>Mole ratio</u> Br ₂ : Ph ₃ PI ₂	<u>10³ κ</u> ohm. ⁻¹ cm. ⁻¹
0	1.77	0.80	2.95
0.16	2.10	0.96	3.47
0.32	2.29	1.33	3.54
0.48	2.50	1.52	3.63
0.64	2.63	1.44	3.66

(4) Iodinebromine vs. triphenylphosphine.

<u>Mole ratio</u> IBr : Ph ₃ P	<u>10³ κ</u> ohm. ⁻¹ cm. ⁻¹	<u>Mole ratio</u> IBr : Ph ₃ P	<u>10³ κ</u> ohm. ⁻¹ cm. ⁻¹
0	0.001	1.12	2.35
0.14	1.37	1.40	2.90
0.36	1.60	1.68	3.25
0.49	1.79	1.96	3.61
0.77	1.95	2.10	4.46
0.98	2.04	2.38	4.34
1.09	2.18	2.52	4.31

(5) Iodine vs. triphenylphosphorus iodobromide.

<u>Mole ratio</u> I ₂ : Ph ₃ PIBr	<u>10³ κ</u> ohm. ⁻¹ cm. ⁻¹	<u>Mole ratio</u> I ₂ : Ph ₃ PIBr	<u>10³ κ</u> ohm. ⁻¹ cm. ⁻¹
0	1.82	0.86	2.65
0.16	1.94	1.02	2.93
0.31	2.11	1.17	3.08
0.47	2.29	1.33	3.09
0.70	2.53		

(6) Bromine vs. triphenylphosphorus iodobromide.

<u>Mole ratio</u> Br ₂ : Ph ₃ PIBr	<u>10³ K</u> ohm. ⁻¹ cm. ⁻¹	<u>Mole ratio</u> Br ₂ : Ph ₃ PIBr	<u>10³ K</u> ohm. ⁻¹ cm. ⁻¹
0	1.62	0.77	2.38
0.19	1.98	0.97	2.64
0.39	2.15	1.16	2.68
0.59	2.20	1.36	2.61

(7) Bromine vs. triphenylphosphine.

<u>Mole ratio</u> Br ₂ : Ph ₃ P	<u>10³ K</u> ohm. ⁻¹ cm. ⁻¹	<u>Mole ratio</u> Br ₂ : Ph ₃ P	<u>10³ K</u> ohm. ⁻¹ cm. ⁻¹
0	0.001	1.55	1.31
0.25	0.72	1.81	1.40
0.52	1.00	2.06	1.67
0.77	1.19	2.32	1.82
1.03	1.29	2.58	1.83
1.29	1.29	2.84	1.85

(8) Iodine vs. triphenylphosphorus dibromide.

<u>Mole ratio</u> I ₂ : Ph ₃ PBr ₂	<u>10³ K</u> ohm. ⁻¹ cm. ⁻¹	<u>Mole ratio</u> I ₂ : Ph ₃ PBr ₂	<u>10³ K</u> ohm. ⁻¹ cm. ⁻¹
0	2.57	1.02	3.44
0.29	2.57	1.16	3.58
0.58	2.65	1.31	3.63
0.72	2.80	1.60	3.54
0.87	3.03	1.75	3.58

(9) Iodinebromide vs. triphenylphosphorus dibromide.

<u>Mole ratio</u> IBr : Ph ₃ PBr ₂	<u>10³ κ</u> ohm. ⁻¹ cm. ⁻¹	<u>Mole ratio</u> IBr : Ph ₃ PBr ₂	<u>10³ κ</u> ohm. ⁻¹ cm. ⁻¹
0	1.96	0.90	2.30
0.33	1.96	1.03	2.50
0.48	1.99	1.09	2.65
0.68	2.20	1.22	2.74
0.78	2.14	1.42	2.78

METHODS OF ANALYSIS.

These have been described in Part 1.

U.V.-Vis SPECTROSCOPY.

This was carried out as described in Part 1.

PART 3.

TRIPHENYLSTIBINE-HALOGEN ADDUCTS.

I N D E X.

	<u>page</u>
RESULTS AND DISCUSSION.	140-169
1. Preparation and Stability of Tertiary Stibine Dihalides.	140
2. Electrolytic Conductance of Triphenyl- antimony Dihalides in Acetonitrile.	140
3. Reaction of Halogens with Triphenyl- antimony Dihalides in Acetonitrile.	147
(a) Reaction of Halogens with Triphenyl- antimony dibromide in Acetonitrile.	147
(b) Reaction of Iodine with Triphenyl- stibine in Acetonitrile.	150
(c) Reaction of Iodine with Triphenyl- antimony Iodobromide in Acetonitrile.	154
(d) Reaction of Iodinebromide with Triphenyl- antimony Diiodide in Acetonitrile.	156
(e) Reaction of Iodinebromide with Triphenylantimony Iodobromide in Acetonitrile.	160
(f) Reaction of Bromine with Triphenyl- antimony Diiodide and Triphenyl- antimony Iodobromide in Acetonitrile.	164
SUMMARY.	168
EXPERIMENTAL PART.	170-177
1. Preparation of Triphenylantimony-Halogen Adducts.	170
(a) Triphenylantimony Dihalides.	170
(b) Other preparations.	171

	<u>page</u>
2. Purification of Materials.	174
(a) Triphenylstibine.	174
3. Conductometric Titrations.	174
4. Conductance Measurements.	177
5. U.V.- Vis Spectroscopy.	177
6. Methods of Analysis.	177

RESULTS AND DISCUSSION.

PREPARATION AND STABILITY OF TERTIARY STIBINE DIHALIDES.

The dihalides of tertiary stibines are very easily formed, either by direct combination of a halogen with a tertiary stibine

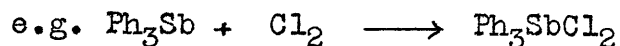

or by the action of a Grignard reagent on an antimony pentahalide

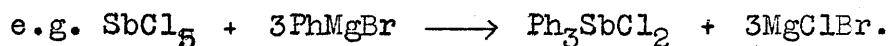

The diiodide, dibromide and dichloride of triphenylstibine have been prepared by halogen addition in a suitable solvent (75) and the preparation of triphenylantimony iodobromide is reported in this thesis.

Unlike their phosphorus and arsenic analogues, the tertiary antimony dihalides are not hygroscopic, and no special precautions are required in handling them.

ELECTROLYTIC CONDUCTANCE OF TRIPHENYLANTIMONY DIHALIDES
IN ACETONITRILE.

Acetonitrile was chosen as solvent for the conductance measurements for the reasons given in Part 1 of the thesis, and also in order that the behaviour of the triphenylantimony

dihalides and the dihalides of triphenylphosphine and triphenylarsine in a polar solvent might be directly compared.

Solutions were made up in the conductance cell, and the conductance immediately determined. Two types of behaviour were apparent. The solutions of triphenylantimony dichloride and dibromide showed a slight change in conductance as they warmed to the temperature of the thermostat, but thereafter gave values which were unchanged over twentyfour hours (Table 28). The molar conductance values, which decreased with increasing concentration, were of such a small magnitude that these compounds are virtually non-electrolytes in acetonitrile.

TABLE 28. Conductance of Ph_3SbCl_2 and Ph_3SbBr_2
in acetonitrile at 25°C.

Compound	C_m mole litre ⁻¹	$10^4 \kappa$ ohm. ⁻¹ cm. ⁻¹	Λ_m ohm. ⁻¹ cm. ² mole ⁻¹
Ph_3SbCl_2	0.022	0.65	0.30
	0.080	1.8	0.22
	0.11	2.3	0.21
Ph_3SbBr_2	0.0081	4.6	0.61
	0.016	5.9	0.38
	0.033	8.3	0.25

In contrast, the pale yellow acetonitrile solutions of triphenylantimony diiodide and iodobromide slowly turned red, the conductance increased with time, and the triiodide ion was present finally in solutions of both dihalides. The triphenylantimony dihalides therefore seem to follow the pattern of their phosphorus and arsenic analogues, in that the addition products with iodine and iodinebromide both disproportionate in acetonitrile to form products containing trihalide ions, but the rate of disproportionation is slow, causing the observed conductance drift.

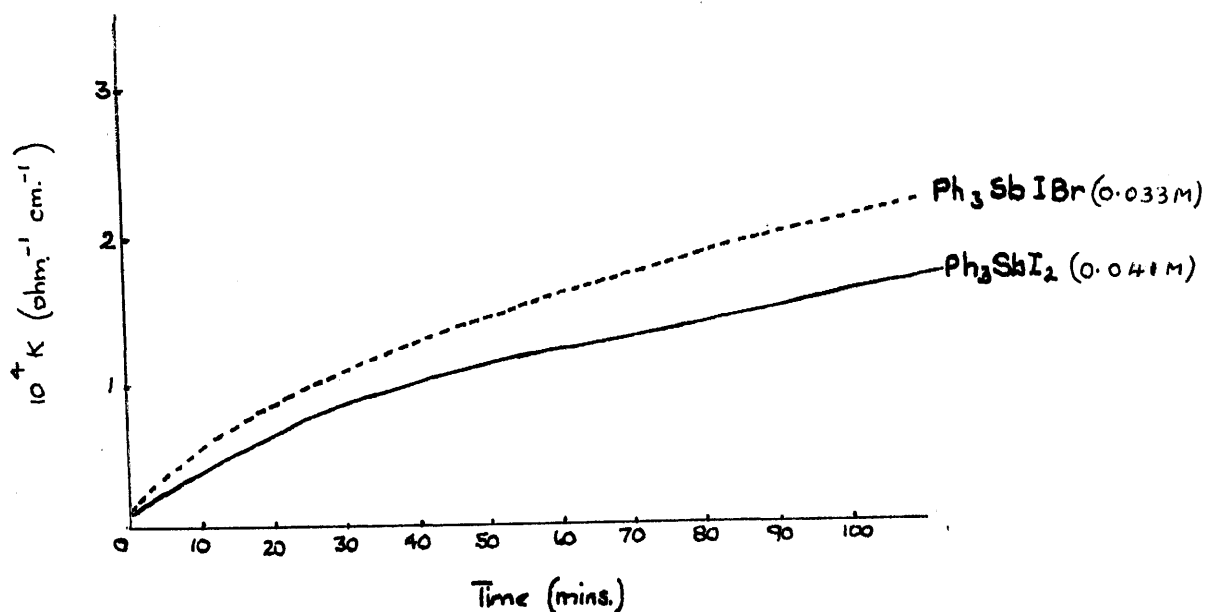

fig.8. Conductance drift of Ph_3SbI_2 and Ph_3SbIBr .

To introduce uniformity into the choice of specific conductance (κ) used to calculate molar conductance (Λ_m), the specific conductance was plotted against time (fig.8) and extrapolated to $t = 0$ (ie. the time when the solution was prepared), and the value of specific conductance at this point was used. Values are given in Table 29.

TABLE 29. Conductance of Ph_3SbI_2 and Ph_3SbIBr
in acetonitrile at 25°C.

Compound	C_m mole litre ⁻¹	$10^4 \kappa$ ohm ⁻¹ cm ⁻¹	Λ_m ohm ⁻¹ cm ² mole ⁻¹
Ph_3SbI_2	0.041	0.12	0.29
	0.095	0.22	0.23
Ph_3SbIBr	0.012	0.10	0.85
	0.033	0.16	0.49

These values show, therefore, that these dihalides are also effectively non-electrolytes in acetonitrile, prior to disproportionation.

Conductance drifts have also been observed by Harris during a study of phosphorus pentabromide in acetonitrile (76) and by Popov and Skelly in acetonitrile solutions of interhalogen compounds (77). The latter attributed the steady rise of specific conductance with time to a slow

ionisation of the type:

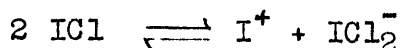

The disproportionations of triphenylantimony diiodide and iodobromide, however, appear to be more complex and also irreversible. After several days, brown crystals formed on the walls of the cell containing the diiodide solution; these had the composition Ph_4SbI_2 , indicating the occurrence of phenyl migration, and representing a novel class of organoantimony halide. The simplest formulation of such a compound is one containing both I^- and I_3^- ions, of formula

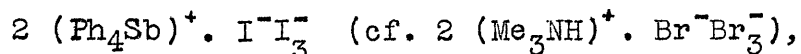

but it has not been possible to obtain more information since no solvent could be found for the solid, and an X-ray investigation has not yet been attempted.

A substance which crystallised by partial evaporation of acetonitrile solutions of triphenylantimony iodobromide had an unexpected C:Sb ratio (22:1) and an I:Br ratio of 1:2, as opposed to 1:1 in the original dihalide. It has not been possible to assign a structure to this compound.

The conductance of trimethylantimony dichloride, dibromide and diiodide in acetonitrile, reported by Hantzsch and Hibbert (34) and Lowry and Simons (35) closely parallels

that of the triphenylantimony dihalides. Trimethyl antimony dichloride and dibromide form effectively non-electrolytic solutions in acetonitrile, whereas the diiodide solution showed a conductance drift and contained the triiodide ion. The natures of both the tertiary alkyl and aryl stibines in acetonitrile, therefore appear to be similar.

Jensen has proposed a resonance structure for triphenylantimony dichloride

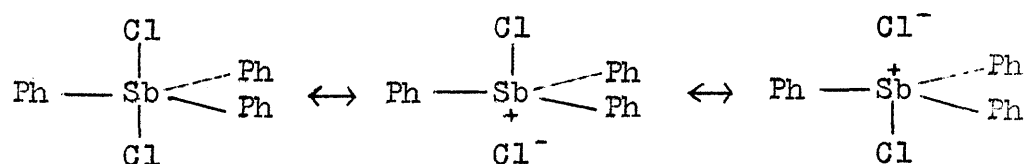

and Wells suggests that trimethylantimony dihalides have a structure intermediate between

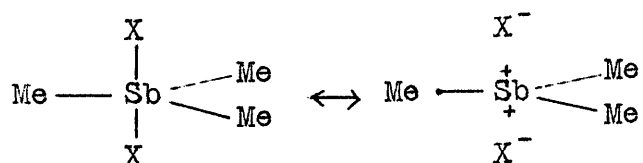

Coates, however, states that these dihalides will dissociate to halotrialkyl(aryl)stibonium halides in water and other polar solvents (38).

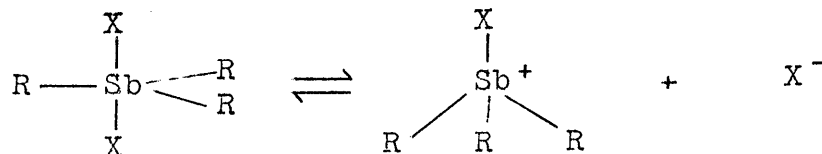

The foregoing conductance values of the triphenyl antimony dihalides and their trimethyl analogues, however, indicate that an ionic form $(R_3SbX)^+X^-$ in acetonitrile is negligible, and Coates' view that a similar ionic dissociation occurs in water is surprising, since Lowry and Simons have attributed the high conductance values in this solvent to the presence of ionic hydroxyhalides (and also, presumably, hydrogen halides).

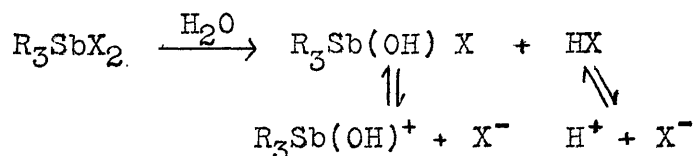

Thus it may be concluded that the dichlorides and dibromides exist as stable covalent species in acetonitrile, whereas the diiodides (and triphenylantimony iodobromide) are not stable in acetonitrile, tending to disproportionate slowly. There is no evidence of simple ionic dissociation of the type suggested by Coates. The significance of these different stabilities is seen in the next section.

REACTION OF HALOGENS WITH TRIPHENYL ANTIMONY
DIHALIDES IN ACETONITRILE.

Triphenylphosphorus and triphenylarsenic dihalides form conducting solutions in acetonitrile, and each dihalide studied has been shown to react with a mole of halogen to form compounds containing a trihalide anion. In contrast, triphenylantimony dichloride and dibromide do not form conducting solutions in acetonitrile, and the diiodide and iodobromide do so only on standing by a slow and apparently complex disproportionation.

Therefore, it was of interest to study the reactions of triphenylantimony dihalides with halogens, since their mode of reaction might well differ from that so far found. For continuity, acetonitrile was again chosen as solvent and conductance methods proved very useful in following the reactions in solution.

REACTION OF HALOGENS WITH TRIPHENYLANTIMONY
DIBROMIDE IN ACETONITRILE.

If the reaction of bromine with triphenylantimony dibromide is accompanied by the formation of a tetrahalide compound, $\text{Ph}_3\text{SbBr}^+\text{Br}_3^-$, then this should be detectable by conductometric titration since a marked increase in conductance would be expected. The results of a titration of bromine against triphenylantimony dibromide are set out in Table 30.

TABLE 30. Titration of Br₂ vs. Ph₃SbBr₂
in acetonitrile.

Mole ratio Br ₂ : Ph ₃ SbBr ₂	10 ⁴ κ ohm. ⁻¹ cm. ⁻¹	Mole ratio Br ₂ : Ph ₃ SbBr ₂	10 ⁴ κ ohm. ⁻¹ cm. ⁻¹
0.00	0.04	1.06	0.34
0.16	0.14	1.31	0.39
0.32	0.19	1.48	0.41
0.57	0.25	1.64	0.45
0.81	0.29	1.72	0.47

The initially colourless solution of dibromide became yellow as soon as bromine was added, and the conductance rose slightly. The increase corresponded to the addition of bromine to acetonitrile containing no solute. Therefore there is no evidence for triphenylantimony dibromide and bromine reacting to give a compound containing the tribromide ion.

Triphenylantimony dibromide alone was isolated from concentrated acetonitrile solutions containing bromine and triphenylstibine in the ratio 1:1 and also 2:1 (equivalent to Ph₃SbBr₂ + Br₂), and this confirms that no higher bromide is formed.

In the same way there is no apparent reaction between the dibromide, and iodine or iodinebromide, and the curves obtained in conductometric titrations, parallel the addition of the halogen to pure acetonitrile. Therefore, there is no evidence for the existence in solution of Ph_3SbBr_4 , $\text{Ph}_3\text{SbIBr}_3$ and $\text{Ph}_3\text{SbI}_2\text{Br}_2$.

REACTION OF IODINE WITH TRIPHENYLSTIBINE IN ACETONITRILE.

A conductometric titration of iodine against triphenyl stibine was carried out with the object of determining whether the diiodide, formed at the 1:1 ratio, would react further with iodine to form a higher iodide. The results are shown in Table 31 and illustrated in fig.9.

Table 31. Titration of I₂ vs. Ph₃Sb in acetonitrile.

Mole ratio I ₂ : Ph ₃ Sb	10 ⁴ κ ohm. ⁻¹ cm. ⁻¹	Mole ratio I ₂ : Ph ₃ Sb	10 ⁴ κ ohm. ⁻¹ cm. ⁻¹
0.00	0.001	1.33	11.3
0.24	0.18	1.58	15.3
0.49	0.24	1.81	18.0
0.72	0.31	2.05	19.4
0.96	0.64	2.10	20.2
1.10	4.90	2.30	20.4
		2.53	20.4

The solution was pale yellow up to I₂ : Ph₃Sb = 1:1, and thereafter became red. The shape of the graph shows two important points. Firstly, there was no rise in conductance, and the triiodide ion was not observed until the 1:1 ratio had been exceeded. Thus it can be concluded that triphenylantimony diiodide does not disproportionate appreciably during its formation in the conductometric

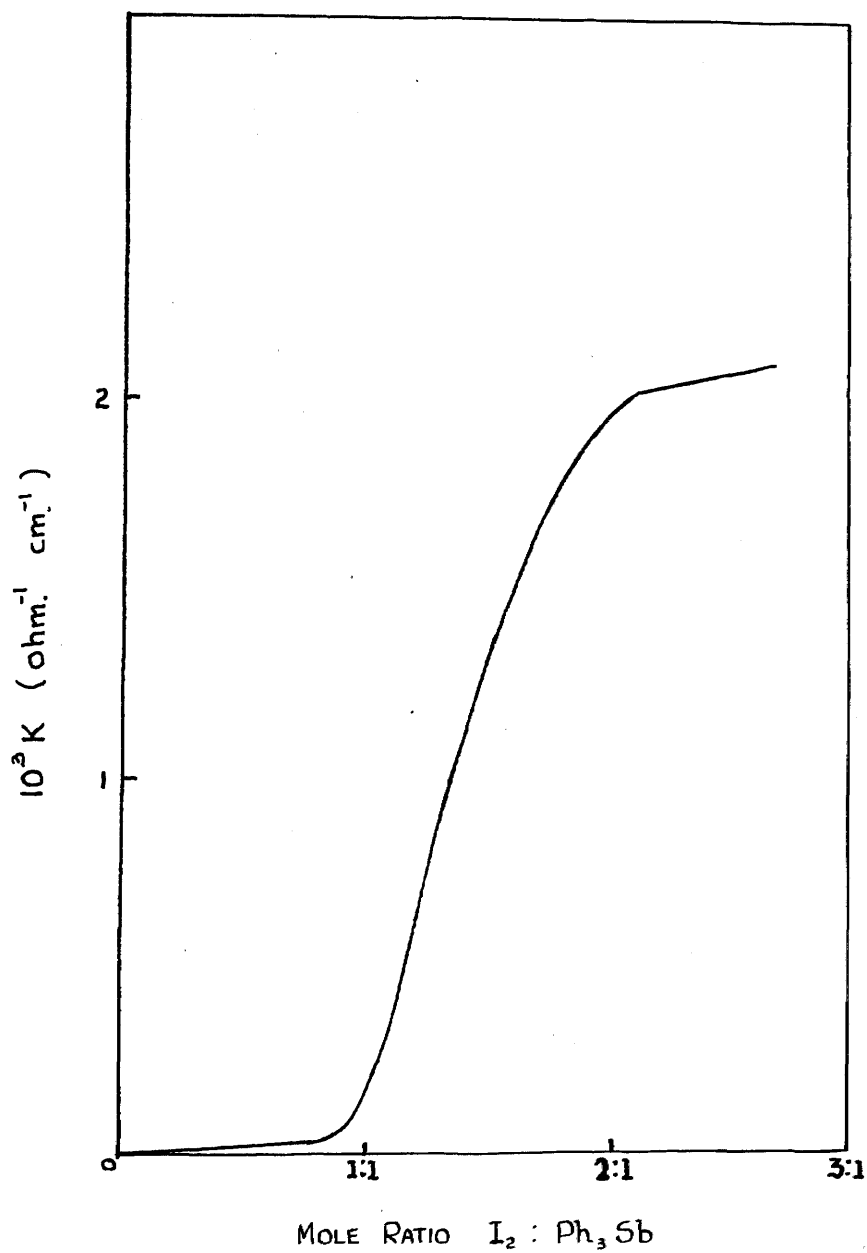
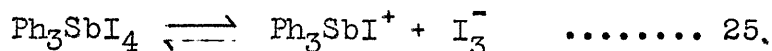

fig. 9. Conductometric titration of I_2 vs. Ph_3Sb
in acetonitrile.

titration. (cf. triphenylarsenic diiodide). Secondly, the rise in conductance after the 1:1 ratio and the break at $I_2 : Ph_3Sb = 2:1$ suggests the formation in solution of triphenylantimony tetraiodide. The triiodide ion was identified at the 2:1 ratio (U.V. spectrum $\lambda = 291,360 \text{ m}\mu$) and it indicates that the tetrahalide ionises



Since a compound containing a triiodide ion is formed from triphenylantimony diiodide, which is essentially covalent in acetonitrile, the question of the mechanism of this reaction is important. Two possible schemes are suggested.

If there is very slight ionisation to iodotriphenylstibonium iodide, then a trihalide ion would be formed by normal halogen/halide ion addition,

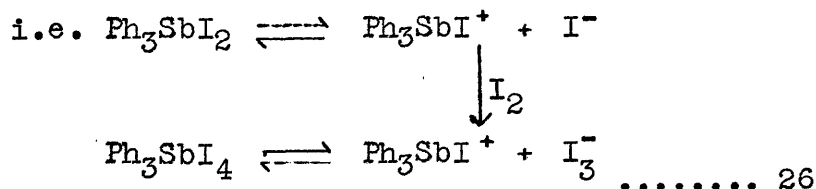

or alternatively, one of the Sb-I bonds of the diiodide (which have a high degree of ionic character) may be broken under the influence of iodine molecules.

however, an attempt was made to isolate a product from such solutions immediately after mixing the reagents, the only solids obtained were the starting materials. From this it would appear that phenyl migration occurs slowly in this system, unlike the triphenylarsenic dichloride/halogen systems, in which it was practically instantaneous.

REACTION OF IODINE WITH TRIPHENYLANTIMONY IODOBROMIDE
IN ACETONITRILE.

Since iodine reacts with triphenylantimony diiodide to form triphenylantimony tetraiodide, $(\text{Ph}_3\text{SbI})^+ \text{I}_3^-$, in acetonitrile, it seemed likely that triphenylantimony triiodobromide ($\text{Ph}_3\text{SbI}_3\text{Br}$) would exist: to investigate this, the reaction of iodine with triphenylantimony iodobromide was studied conductometrically in acetonitrile.

In practice, triphenylstibine was titrated to the 1:1 ratio with iodinebromide, which was then replaced by iodine as titrant.

The result was a conductance - composition graph similar to that in fig.8, from which the existence of triphenylantimony triiodobromide in solution is supported. It is presumably formed by mechanisms similar to schemes 26 or 27, since the triiodide ion was observed in solution only beyond the zero mole ratio of $\text{I}_2 : \text{Ph}_3\text{SbIBr}$. The

triiodide ion must therefore (by analogy with the arsenic and phosphorus triiodobromides) arise from the dissociation:

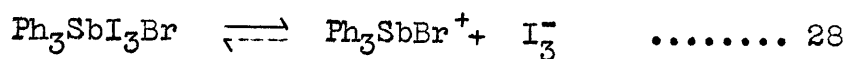

and not from the slow disproportionation of the iodobromide (page 142).

Again it was not possible to isolate the triphenyl-antimony tetrahalide in solid form, the product which crystallised on standing, having an I:Br ratio of 1:2.

Therefore it has not been possible to prepare any members of the series $\text{Ph}_3\text{SbI}_{(4-n)}\text{Br}_n$, although Ph_3SbI_4 and $\text{Ph}_3\text{SbI}_3\text{Br}$ have been indicated in solution. The importance of their existence in solution is well illustrated in the following studies of other systems.

REACTION OF IODINEBROMIDE WITH TRIPHENYLANTIMONY
DIODIDE IN ACETONITRILE.

As an alternative approach to triphenylantimony triiodobromide, the reaction of iodinebromide with triphenylantimony diiodide was studied, and the results of a conductometric analysis (Table 32, fig.10) differed from any systems previously examined.

TABLE 32. Titration of IBr vs. Ph₃SbI₂ in acetonitrile.

Mole ratio IBr : Ph ₃ SbI ₂	10 ⁴ κ ohm. ⁻¹ cm. ⁻¹	Mole ratio IBr : Ph ₃ SbI ₂	10 ⁴ κ ohm. ⁻¹ cm. ⁻¹
0.00	0.90	1.63	17.6
0.25	15.2	1.86	12.0
0.47	21.5	2.12	3.80
0.70	24.3	2.33	6.20
0.94	25.4	2.56	8.60
1.05	24.9	2.79	10.6
1.41	21.0	3.03	12.4

The shape of the curve up to the maximum at IBr : Ph₃SbI₂ = 1:1 exactly parallels the systems I₂/Ph₃SbIBr, and I₂/Ph₃SbI₂ (fig.9), and the maximum supports the formation in solution of triphenylantimony triiodobromide.

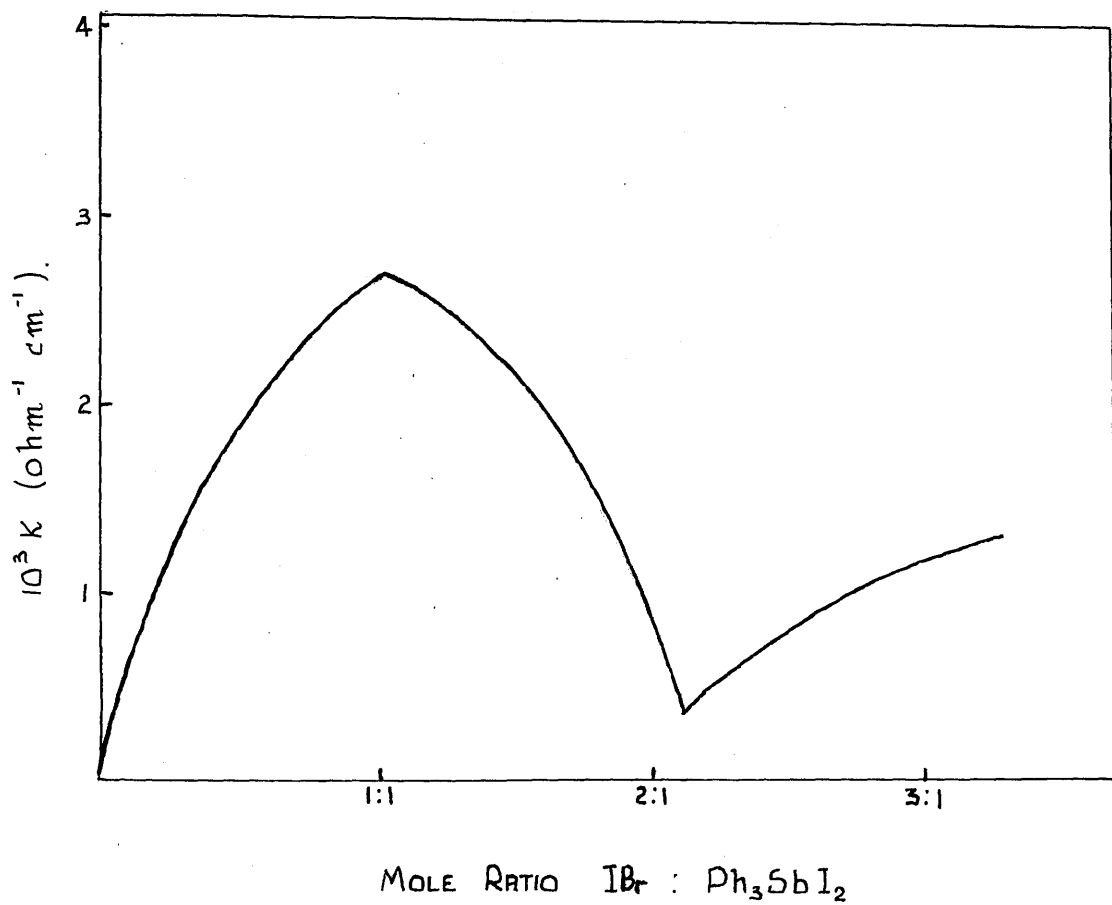

fig.10. Conductometric titration of IBr vs. Ph_3SbI_2 in acetonitrile.

The novel feature of this system is the rapid fall in conductance after the maximum at the 1:1 ratio, and the production of a minimum at $\text{IBr} : \text{Ph}_3\text{SbI}_2 = 2:1$.

The ultraviolet and visible spectra of the solution were recorded at different compositions during the titration and are given in Table 33.

TABLE 33. Solution spectra of the system IBr vs. Ph_3SbI_2 .

Composn. of solution $\text{IBr} : \text{Ph}_3\text{SbI}_2$	U.V. maxima $\text{m}\mu$	U.V. indicates	Visible maxima $\text{m}\mu$	Visible indicates
0.5 : 1	292,362	I_3^- (a)	-	no X_2
1 : 1	292,362	I_3^-	-	no X_2
1.5 : 1	292,362	I_3^-	460(w)	I_2 (c)
2 : 1	-	no X_3^-	462	I_2
3 : 1	256	IBr_2^- (b)	band 420-460	I_2, IBr (d)

(a) for I_3^- , $\lambda = 291,360 \text{ m}\mu$

(b) for IBr_2^- , $\lambda = 256 \text{ m}\mu$

(c) for I_2 , $\lambda = 465 \text{ m}\mu$

(d) for IBr , $\lambda = 420 \text{ m}\mu$

Although it was not possible to isolate a stoichiometric compound at $\text{IBr} : \text{Ph}_3\text{SbI}_2 = 1:1$, triphenylantimony dibromide was isolated at the 2:1 mole ratio.

Therefore, the isolation of the dibromide combined with

the spectral information, show that the reactions in solution must be :

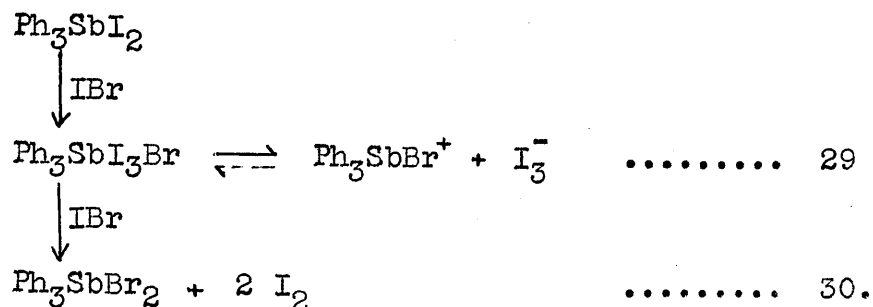

That is, triphenylantimony diiodide is ultimately converted to the more stable triphenylantimony dibromide, via the intermediate formation of triphenylantimony triiodobromide, which is unstable in the presence of excess iodine bromide.

The low but measurable conductance at the 2:1 ratio is due to ionisation of the iodine in acetonitrile,

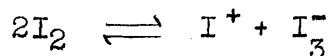

and beyond this ratio to the increasing concentration of the more highly conducting iodinebromide. The graph beyond the 2:1 ratio was indeed similar to that observed in the addition of iodinebromide to triphenylantimony dibromide in acetonitrile (see page 149).

The strong tendency for the dibromide to be formed appears to control the course of the reaction, and this is a feature not previously observed in the arsenic and phosphorus systems.

REACTION OF IODINE BROMIDE WITH TRIPHENYLANTIMONY
IODOBROMIDE IN ACETONITRILE.

Since iodine does not react with triphenylantimony dibromide, there is no evidence for $\text{Ph}_3\text{SbI}_2\text{Br}_2$, but an alternative approach to this compound is the reaction of iodine bromide with triphenylantimony iodobromide, and this reaction was studied since it has already been shown that iodine reacts with the iodobromide to form triphenylantimony triiodobromide in acetonitrile solution. The reaction of iodinebromide with triphenylantimony iodobromide was studied conductometrically, and the graphic results (fig.11) gave a curve of shape similar to that of fig.10, ($\text{IBr}/\text{Ph}_3\text{SbI}_2$). In this case, however, the maximum in conductance occurs at $\text{IBr} : \text{Ph}_3\text{SbIBr} = 0.5:1$, and the minimum at $\text{IBr} : \text{Ph}_3\text{SbIBr} = 1:1$, as opposed to $\text{IBr} : \text{Ph}_3\text{SbI}_2 = 1:1$ and $2:1$ in fig.10.

The changes in the U.V. and visible spectra with respect to the different portions of the graph were the same as given in Table 33. That is, the conductance maximum concurs with the maximum concentration of triiodide ion, which is converted into the molecular iodine at the minimum ratio. Also at the minimum, triphenylantimony dibromide was isolated.

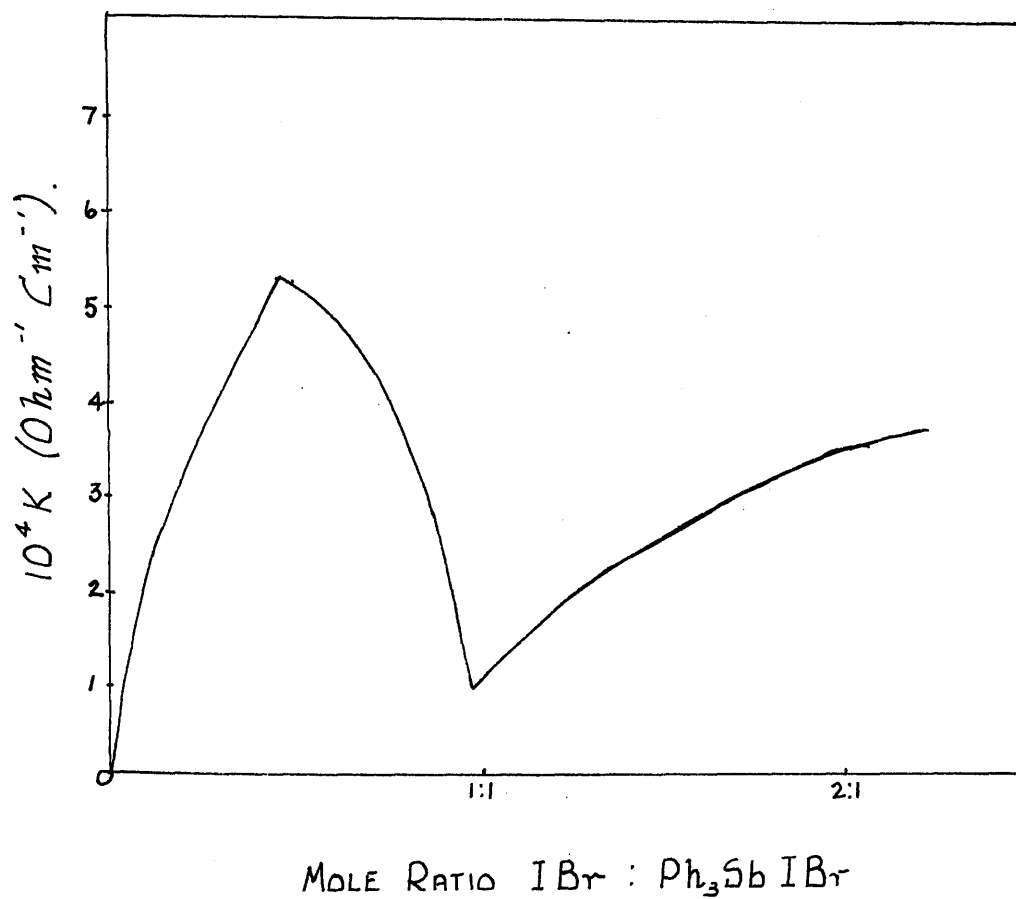
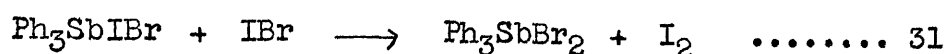
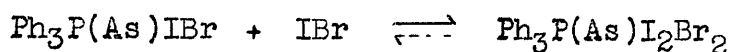

fig.11. Conductometric titration of IBr vs. Ph₃SbIBr
in acetonitrile.

Therefore, triphenylantimony iodobromide must react with a mole of iodine bromide thus :



in contrast with the reaction of the phosphorus and arsenic analogues -



That is, the iodobromide is converted to the more stable dibromide by the addition of a bromine-containing halogen.

The conductance maximum at $\text{IBr} : \text{Ph}_3\text{SbIBr} = 0.5:1$ can be explained in terms of the iodine produced as reaction 31 proceeds, reacting immediately with unreacted triphenylantimony iodobromide

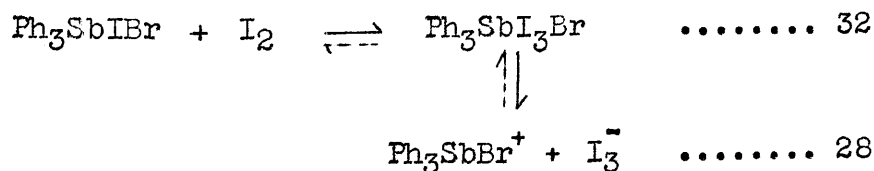

since there is no molecular iodine in solution before the conductance maximum. Two processes are thus occurring simultaneously, and on adding reactions 31 and 32, the overall equation for the reaction up to the maximum becomes

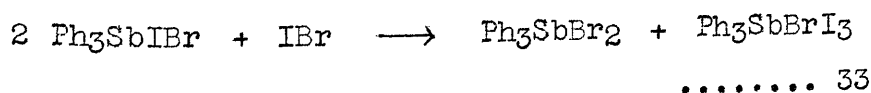

Thus, half a mole of iodinebromide converts the covalent triphenylantimony iodobromide to the covalent dibromide and the highly conducting triphenylantimony triiodobromide. Hence the conductance rises as reaction 33 proceeds, but this must reach a maximum when all of the iodobromide has reacted. The reaction will then be

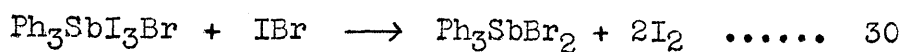

and therefore equation 31 represents the overall reaction, which is to produce triphenylantimony dibromide and iodine only.

Disproportionation of triphenylantimony iodobromide.

This is too slow to interfere with the conductometric studies. If the first step of the disproportionation is molecular dissociation to triphenylstibine and iodinebromide, then the latter would react as in 31, and the iodine so formed could then react further with the iodobromide to form bromotriphenylstibonium triiodide. This would account for the formation of the triiodide ion in solutions of the iodobromide.

REACTION OF BROMINE WITH TRIPHENYLANTIMONY DIIODIDE
AND TRIPHENYLANTIMONY IODOBROMIDE IN ACETONITRILE.

The reaction between bromine and triphenylantimony diiodide gives a conductance graph similar to fig.11, but in addition there is a break at $\text{Br}_2 : \text{Ph}_3\text{SbI}_2 = 2:1$, instead of a regular rise in conductance beyond the 1:1 ratio (fig.12). The composition of the solution, measured spectrophotometrically at various stages, again shows that the maximum in conductance is paralleled by the maximum concentration of triiodide ion, and triphenylantimony dibromide was isolated at the conductance minimum at $\text{Br}_2 : \text{Ph}_3\text{SbI}_2 = 1:1$, at which molecular iodine is also present.

Thus the overall reaction of bromine with triphenylantimony diiodide is

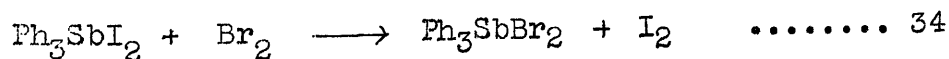

and the rise in conductance up to the 2:1 ratio is due to reaction of the bromine with iodine from reaction 34 to produce iodinebromide, which forms conducting solutions in acetonitrile.

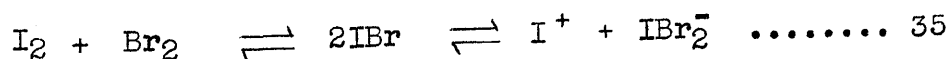

This latter reaction has been confirmed by titrating bromine against iodine in acetonitrile, when a graph of

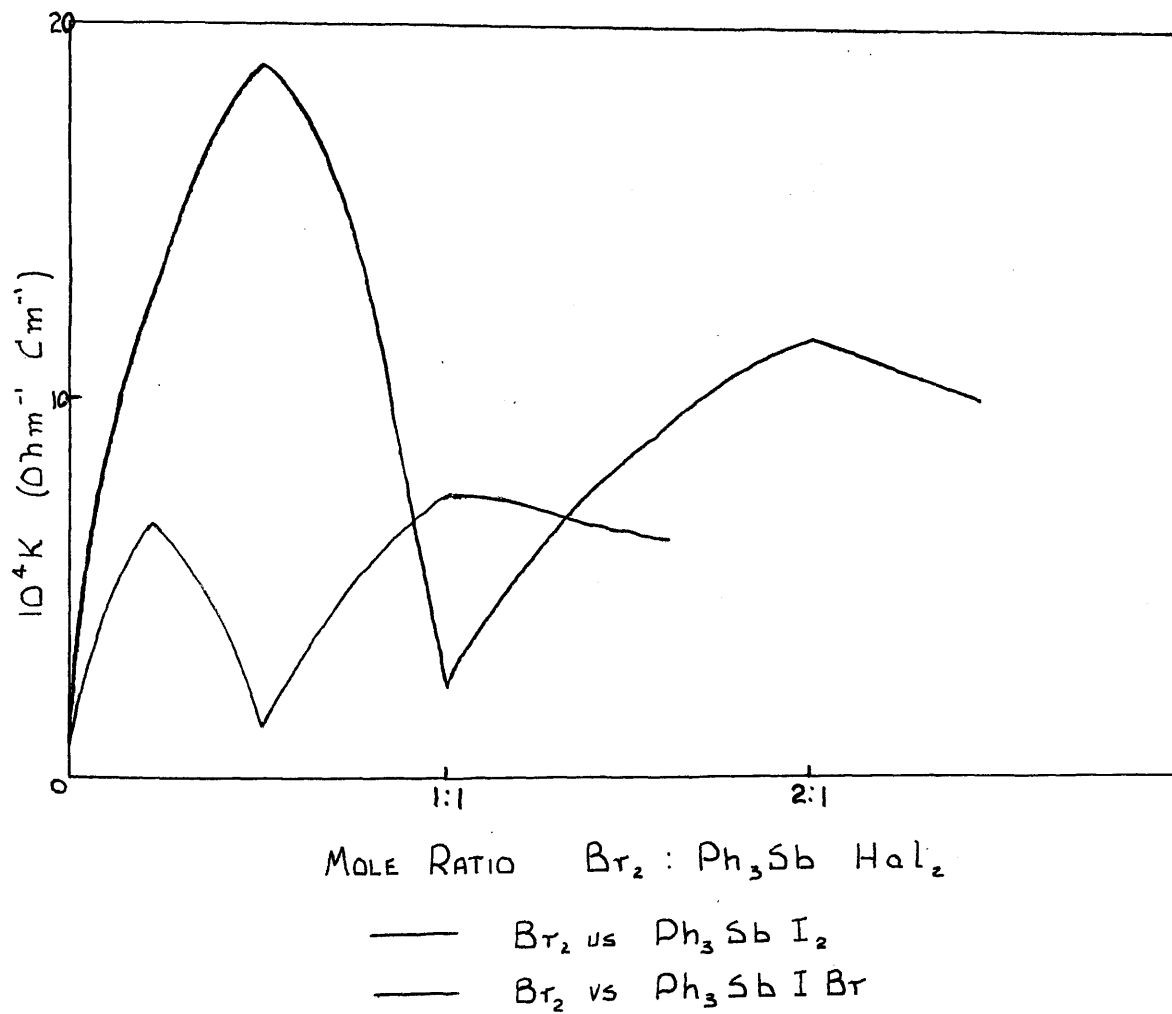

fig.12. Conductometric titration of 1) Br_2 vs. Ph_3SbI_2
2) Br_2 vs. Ph_3SbIBr
in acetonitrile.

similar shape was obtained. Also, the spectrophotometric changes in the U.V. and visible spectra were similar to those in the $\text{Br}_2/\text{Ph}_3\text{SbI}_2$ system.

TABLE 34. U.V. and Visible spectra of $\text{Br}_2/\text{Ph}_3\text{SbI}_2$
and Br_2/I_2 in acetonitrile.

Composn. $\text{Br}_2:\text{Ph}_3\text{SbI}_2$	Visible maxima ($\text{m}\mu$)	U.V. maxima ($\text{m}\mu$)	Composn. $\text{Br}_2 : \text{I}_2$	Visible maxima ($\text{m}\mu$)	U.V. maxima ($\text{m}\mu$)
1:1	465	293(w) 360(w)	0:1	465	293(w) 360(w)
2:1	425	256	1:1	420	256

(See Table 33, page 158.)

In this system, the highly conducting intermediate is triphenylantimony tetraiodide, and the reactions may be represented

to maximum (0.5:1)

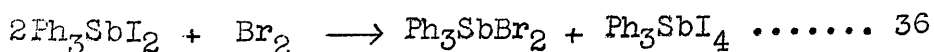

maximum to minimum (1:1)

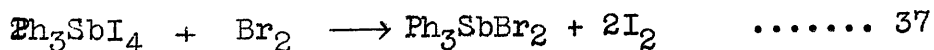

overall reaction to minimum (0:1 \rightarrow 1:1)

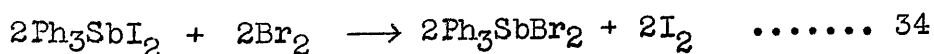

beyond minimum (2:1)



Similarly, the overall reaction of bromine and triphenyl-antimony iodobromide is

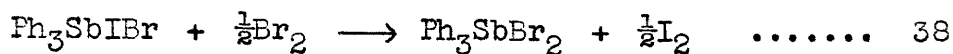

and in this system a maximum occurs due to the formation of highly conducting triphenylantimony triiodobromide, arising from the reaction of iodine formed in 38, with unreacted iodobromide. From equation 39 it is clear that the maximum should occur at $\text{Br}_2 : \text{Ph}_3\text{SbIBr} = 0.33:1$, but in fact it was found at ca. 0.28:1.

The reactions may be written:

to maximum (0.33:1)

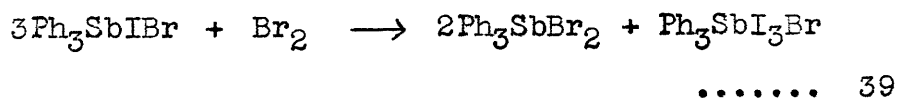

maximum to minimum (0.5:1)

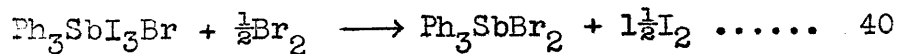

overall to minimum (0.5 : 1)

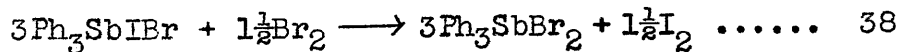

beyond minimum to break at 1:1

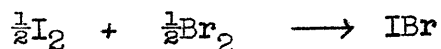

SUMMARY:

Conductance measurements show that triphenylantimony dichloride and dibromide form stable effectively non-conducting solutions in acetonitrile. The diiodide and iodobromide, however, although initially forming non-conducting solutions in acetonitrile, undergo a slow disproportionation reaction which produces ions and causes a conductance drift. The triiodide ion was finally present in both solutions. An organoantimony halide of novel stoichiometry, Ph_4SbI_2 , precipitated on standing, from acetonitrile solutions of the diiodide, showing that phenyl migration also occurs in this system.

The conductance values of the triphenylantimony dihalides are of the same order of magnitude as those reported for trimethylantimony dichloride, dibromide and diiodide.

The nature of the addition of the halogens to the dihalides differs from that found for the triphenylphosphorus and arsenic dihalides. Triphenylantimony dibromide does not combine with the halogens to form higher halides, and of the tetrahalide series $\text{Ph}_3\text{SbI}(4-n)\text{Br}_n$, only Ph_3SbI_4 and $\text{Ph}_3\text{SbI}_3\text{Br}$ were indicated by conductometric analyses. (Breaks in conductance-composition graphs at $\text{I}_2:\text{Ph}_3\text{SbI}_2 = 1:1$; $\text{I}_2:\text{Ph}_3\text{SbIBr} = 1:1$; $\text{IBr}:\text{Ph}_3\text{SbI}_2 = 1:1$.) Ultraviolet spectra suggested the ionisations $\text{Ph}_3\text{SbI}^+\text{I}_3^-$ and $\text{Ph}_3\text{SbBr}^+\text{I}_3^-$. Solids

of these compositions could not be prepared, and in an attempt to prepare Ph_3SbI_4 , the solid isolated was $\text{Ph}_4\text{Sb}^+ \text{I}_3^-$, which again shows the presence of phenyl migration.

It is suggested that the formation of $\text{Ph}_3\text{SbI}^+ \text{I}_3^-$ and $\text{Ph}_3\text{SbBr}^+ \text{I}_3^-$ is perhaps the first instance of formation of tetrahalides by halogen addition to covalent dihalides, and occurs because of the high degree of ionic character of the Sb-I bond.

Conductometric analyses of certain systems showed maxima coinciding with the formation of the triiodide ion at fractional ratios, (eg. $\text{Br}_2:\text{Ph}_3\text{SbIBr} = 0.28:1$; $\text{Br}_2:\text{Ph}_3\text{SbI}_2 = 0.5:1$; $\text{IBr}:\text{Ph}_3\text{SbIBr} = 0.5:1$), followed by minima (eg. $\text{Br}_2:\text{Ph}_3\text{SbIBr} = 0.5:1$; $\text{Br}_2:\text{Ph}_3\text{SbI}_2 = 1:1$; $\text{IBr}:\text{Ph}_3\text{SbIBr} = 1:1$) at which only triphenylantimony dibromide and iodine were present. The reactions in solution leading to such results have been discussed at some length, and the general conclusion is that Ph_3SbI_2 and Ph_3SbIBr are converted to the more stable Ph_3SbBr_2 by the addition of IBr and Br_2 , and that the conversion proceeds through the intermediate formation of the highly conducting tetrahalides iodotriphenylstibonium triiodide and bromotriphenylstibonium triiodide.

EXPERIMENTAL PART.

PREPARATION OF TRIPHENYLANTIMONY-HALOGEN ADDUCTS

1) Triphenylantimony dihalides.

Preparation of triphenylantimony dichloride.

Triphenylstibine was dissolved in chloroform, and chlorine in a nitrogen stream was bubbled through the solution. White crystals precipitated and free chlorine coloured the solution green when the reaction was complete. The crystals were filtered in the drybox, washed with petroleum ether, and dried in vacuo, m.p. 143°.

(Found: Cl, 16.9. Calc. for $C_{18}H_{15}Cl_2Sb$, Cl, 16.6%.
m.p. 143°.)

Preparation of triphenylantimony dibromide.

Bromine (1.617 g., 0.0101 mole) dissolved in acetonitrile (15 ml.) was added to triphenylstibine (3.569 g., 0.0101 mole) dissolved in acetonitrile (40 ml.). The bromine solution decolourised, and white crystals precipitated. They were filtered in the drybox, washed with petroleum ether, and dried in vacuo. m.p. 215°. (Found: Br, 30.7. Calc. for $C_{18}H_{15}Br_2Sb$, Br, 31.2%. m.p. 216°)

Preparation of triphenylantimony iodobromide.

Iodinebromide (0.00920 mole) dissolved in acetonitrile (15 ml.) was added to triphenylstibine (3.245 g.,

0.00920 mole) dissolved in acetonitrile (50 ml.). The solution became very pale yellow, and crystals of the same colour precipitated. These were filtered in the drybox, washed with petroleum ether, and dried in vacuo. m.p. 186°. (Found: C,38.3; H,2.8; Br,14.4; I,22.8, Sb,21.7. $C_{18}H_{15}BrISb$ requires C,38.6; H,2.7; Br,14.3; I,22.6; Sb,21.8%.)

Preparation of triphenylantimony diiodide.

Iodine (1.805 g., 0.00712 mole) in acetonitrile (40 ml.) was added to triphenylstibine (2.516 g., 0.00712 mole) dissolved in acetonitrile. The solution became pale yellow, and pale yellow crystals precipitated. These were filtered in the drybox, washed with petroleum ether, and dried in vacuo. m.p. 156°. (Found: I,41.9. Calc. for $C_{18}H_{15}I_2Sb$: I,41.8% m.p. 153°.)

Other Preparations.

Attempted preparation of triphenylantimony tetraiodide.

Iodine (4.486 g., 0.0177 mole) dissolved in acetonitrile was added to triphenylstibine (3.118 g., 0.00885 mole) dissolved in acetonitrile. Pale yellow crystals precipitated but as addition continued, these dissolved and when addition was complete a clear red solution remained. On standing overnight, orange crystals precipitated. These were filtered

in the drybox, washed with anhydrous ether, and dried in vacuo, m.p. 176°. (Found: C,36.3; H,2.5; I,47.6. Calc. for $C_{24}H_{20}I_3Sb$, C,35.5; H,2.5; I,47.0. m.p. 175°.) That is, the crystals which precipitated are tetraphenylstibonium triiodide.

On freeze drying equimolar solutions of iodine and triphenylantimony diiodide immediately after mixing, and extracting the resultant solid mass with carbon tetrachloride, the solvent became purple, due to free iodine and the resultant solid was identified as the diiodide. (Found: I,41.7; Calc. for $C_{18}H_{15}I_2Sb$: I,41.8%.)

Attempted preparation of triphenylantimony triiodobromide.

Iodinebromide (0.00932 mole) in acetonitrile (15 ml.) was added to triphenylstibine (3.288 g., 0.00932 mole) in acetonitrile (40 ml.). Triphenylantimony iodobromide precipitated. Iodine (2.367 g., 0.00932 mole) was added to the suspension of triphenylantimony iodobromide, which redissolved, leaving a clear red solution. On standing overnight, orange/red crystals precipitated. These were filtered in the drybox, washed with anhydrous ether, and dried in vacuo, m.p. 200°. (Found: C,40.6; H,2.9; Br,21.4; I,16.3%.) These figures give an empirical composition of $C_{26.3}H_{22.2}Sb_{1.2}IBr_2$. No trihalide ion was observed in the U.V. spectrum of acetonitrile solutions of the compound.

Preparation of Ph_4SbI_2 .

Triphenylantimony diiodide dissolved in acetonitrile forms a pale yellow solution which latterly becomes red as the compound disproportionates. After 1 - 3 days, yellow/brown crystals form on the walls of the cell. These were filtered off in the drybox, washed with anhydrous ether, and dried in vacuo, m.p. $206-8^\circ$, (Found: C,41.9; H,3.0; I,37.4. $\text{C}_{24}\text{H}_{20}\text{I}_2\text{Sb}$ requires C,42.1; H,2.9; I,37.1%.)

A solution of triphenylantimony iodobromide in acetonitrile similarly became red and on partial evaporation, yellow crystals precipitated which were filtered, washed and dried as above. (Found: C,41.9; H,2.8; Br,21.5; I,19.8%.) This gives an empirical formula of $\text{C}_{22}\text{H}_{18}\text{Sb}_{0.73}\text{IBr}_{1.7}$.

Triphenylantimony dibromide from conductometric titrations.

In those titrations where minima were found, concentrated solutions were made up in the same ratio, and the dibromide precipitated on partial evaporation of the solution. It was filtered and identified by melting point and analysis. The presence of iodine in solution at the minima was shown spectroscopically, and it was also identified by freeze-drying the solutions and extracting the solid with carbon tetrachloride, which became purple.

PURIFICATION OF MATERIALS:

The purification of acetonitrile, chlorine, bromine, iodinebromide, and iodine have been detailed in Part 1. The halogen adducts were not further purified.

Triphenylstibine.

Triphenylstibine was prepared by the Grignard reaction of phenylmagnesiumbromide and antimony trichloride.(78) It was recrystallised from 40-50 petroleum ether to constant melting point.(m.p. 50°).

CONDUCTOMETRIC TITRATIONS:

Conductometric titrations were carried out as described in Appendix 2. Where halogen was titrated against dihalide the dihalide was prepared in situ. The results of some experiments whose results were not tabulated in the

"Results and Discussion" section are given below.

Titration of I₂ vs. Ph₃SbBr₂.

Mole ratio I ₂ :Ph ₃ SbBr ₂	10 ⁴ κ ohm. ⁻¹ cm. ⁻¹	Mole ratio I ₂ :Ph ₃ SbBr ₂	10 ⁴ κ ohm. ⁻¹ cm. ⁻¹
0	0.04	1.02	1.42
0.29	1.22	1.30	1.49
0.58	1.28	1.60	1.55
0.73	1.33	1.88	1.62

Titration of IBr vs. Ph_3SbBr_2 .

Mole ratio $\text{IBr}:\text{Ph}_3\text{SbBr}_2$	$10^4 \kappa$ $\text{ohm}^{-1}\text{cm}^{-1}$	Mole ratio $\text{IBr}:\text{Ph}_3\text{SbBr}_2$	$10^4 \kappa$ $\text{ohm}^{-1}\text{cm}^{-1}$
0	0.035	0.87	8.84
0.21	3.48	1.06	9.97
0.43	5.61	1.28	11.2
0.67	7.39	1.49	12.3

Titration of I_2 vs. Ph_3SbIBr .

Mole ratio $\text{I}_2:\text{Ph}_3\text{SbIBr}$	$10^3 \kappa$ $\text{ohm}^{-1}\text{cm}^{-1}$	Mole ratio $\text{I}_2:\text{Ph}_3\text{SbIBr}$	$10^3 \kappa$ $\text{ohm}^{-1}\text{cm}^{-1}$
0	0.03	0.84	1.69
0.15	0.87	0.98	1.71
0.30	1.25	1.05	1.73
0.45	1.44	1.21	1.75
0.61	1.57	1.30	1.75

Titration of IBr vs. Ph₃SbIBr.

Mole ratio IBr:Ph ₃ SbIBr	10 ⁴ κ ohm. ⁻¹ cm. ⁻¹	Mole ratio IBr:Ph ₃ SbIBr	10 ⁴ κ ohm. ⁻¹ cm. ⁻¹
0	0.24	1.00	2.32
0.13	3.00	1.13	0.92
0.26	4.73	1.26	1.48
0.38	5.15	1.51	2.13
0.51	4.96	1.78	2.65
0.76	3.21	2.00	2.95

Titration of Br₂ vs. Ph₃SbI₂.

Mole ratio Br ₂ :Ph ₃ SbI ₂	10 ⁴ κ ohm. ⁻¹ cm. ⁻¹	Mole ratio Br ₂ :Ph ₃ SbI ₂	10 ⁴ κ ohm. ⁻¹ cm. ⁻¹
0	0.900	1.05	2.49
0.12	7.14	1.18	4.69
0.24	11.7	1.40	7.52
0.35	13.6	1.64	9.42
0.47	14.3	1.87	11.0
0.58	13.5	1.99	11.7
0.71	12.1	2.10	11.6
0.93	5.15	2.22	11.5

Titration of Br₂ vs. Ph₃SbIBr.

Mole ratio Br ₂ :Ph ₃ SbIBr	10 ⁴ κ ohm. ⁻¹ cm. ⁻¹	Mole ratio Br ₂ :Ph ₃ SbIBr	10 ⁴ κ ohm. ⁻¹ cm. ⁻¹
0	0.35	0.70	4.46
0.10	5.16	0.90	6.90
0.20	6.48	1.00	7.52
0.30	6.16	1.20	7.45
0.40	4.35	1.50	7.08
0.50	1.23		

CONDUCTANCE MEASUREMENTS:

These were carried out in a dipping electrode cell as described in part 1. In the cases of the diiodide and iodobromide, the conductance drift was measured and Δt plotted against $\Delta \kappa$. The graph was extrapolated to $t = 0$, and a value for κ thus deduced.

U.V. - Vis SPECTROSCOPY.

METHODS OF ANALYSIS.

These were carried out as described in Part 1.

P A R T 4.

NOTE ON (i) TRIPHENYLAMINE-HALOGEN REACTIONS.

(ii) TRIPHENYL BISMUTHINE-HALOGEN REACTIONS.

GENERAL CONCLUSIONS.

NOTE ON THE REACTIONS OF HALOGENS WITH TRIPHENYLAMINE
AND TRIPHENYL BISMUTHINE IN ACETONITRILE.

The main topic of this research has been a study of triphenylarsine-halogen adducts, and the adducts of triphenylphosphine and triphenylstibine have also been investigated for comparison. For completeness, the reactions of the halogens with triphenylamine and triphenylbismuthine were briefly examined, and the findings of these experiments are now discussed.

(i) Triphenylamine-halogen systems.

Triphenylamine does not appear to form addition compounds with the halogens. On mixing equimolar acetonitrile solutions of bromine and triphenylamine under conditions which give, for example, triphenylarsine-halogen adducts, neither triphenylnitrogen dibromide nor triphenylnitrogen tetrabromide were formed. Instead, tri-p-bromophenylamine precipitated (Found: C,45.0; H,2.8; Br,50.0; N,3.2. Calc. for $C_{18}H_{12}Br_3N$: C,44.9; H,2.5; Br,49.8; N,2.9%) and on freeze-drying the solution, p-bromophenyl diphenylamine was obtained. (Found: C,66.1; H,4.3; Br,24.3; N,4.3. Calc. for $C_{18}H_{14}BrN$: C,66.7; H,4.3; Br,24.7; N,4.3%.) On addition of more than a mole of bromine, tri-p-bromophenylamine only was obtained. The siting of the bromine on the benzene ring in the para position was deduced from the infrared spectra of the compounds. (Appendix 4.)

Thus, the reaction of bromine with triphenylamine produces ring substitution and not addition. This is in keeping with the inability of the nitrogen atom to form pentacovalent compounds, but although an ionic ammonium salt, $\text{Ph}_3\text{NHal}^+ \text{Hal}^-$, is possible in principle, quaternary compounds derived from triphenylamine are not common, the only known examples being triphenylammonium salts (79).

The reaction of triphenylamine with iodinebromide yielded red viscous oils, and with iodine, solids of non-stoichiometric composition were obtained. Since it was clear that these reactions were not proceeding by halogen addition analogous to the arsenic, phosphorus and antimony systems, they were not further studied.

(ii) Triphenylbismuthine-halogen reactions.

The reactions of triphenylbismuthine with the halogens have been studied by Challenger and Allpress (80) and more recently by Harris and Inglis (81). Triphenylbismuth dichloride and dibromide were readily prepared by normal halogen addition to triphenylbismuthine, and both were non-conductors in acetonitrile. (Ph_3BiCl_2 : $\Delta m = 0.01 \text{ ohm}^{-1} \text{ cm}^2 \text{ mole}^{-1}$ at $\text{cm} = 0.024$. Ph_3BiBr_2 : $\Delta m = 0.04 \text{ ohm}^{-1} \text{ cm}^2 \text{ mole}^{-1}$ at $\text{cm} = 0.011$.)

Triphenylbismuth diiodide and iodobromide are not stable at room temperature, and break down to bismuthines (III) ($\text{Ph}_n\text{BiHal}_{(3-n)}$) and phenylhalides (80)(81). This break down may be attributed to the "inert pair" of 6 s electrons of bismuth (82)(83)(84), which causes the Bi^{III} state to be much more prevalent than the Bi^{V} state. Indeed triphenylbismuth dichloride and dibromide are among the relatively few Bi^{V} compounds known. The lower stability of the diiodide and iodobromide can be attributed to the weakness of the Bi-I bond, compared to the Bi - Cl and Bi - Br bonds, and to the effect of the lower electronegativity of the iodine on the $d\text{sp}^3$ hybridisation of the bismuth.

This is, as might be expected, the only instance in the studies of triphenylsubstituted Group Vb halogen adducts in which the inertness of a pair of s electrons appears to assume importance. There is no evidence for tetrahalides of the type $\text{Ph}_3\text{BiHal}_4$ (81).

GENERAL CONCLUSIONS.

Triphenylamine does not form halogen addition compounds, and instead, ring substitution reactions occur. Under suitable conditions, halogen addition (Cl_2 , Br_2 , I_2 and I Br) to triphenylphosphine, triphenylarsine, triphenylstibine and triphenylbismuthine, produces dihalides at room temperature, with the exception of triphenylbismuth diiodide and iodobromide (p.180). If the solvent is moist acetonitrile then in the case of triphenylphosphine, triphenylphosphonium halides are isolated.

The electrolytic properties of the dihalides have been studied in acetonitrile. The molar conductance values of the dichlorides and dibromides decrease with the increasing atomic number of the Group Vb element, ($\Lambda_m \text{P}$, $\Lambda_m \text{As}$, $\Lambda_m \text{Sb}$, $\Lambda_m \text{Bi} \sim 60, 15, <1, \ll 1 \text{ ohm}^{-1} \text{ cm}^2 \text{ mole}^{-1}$ respectively, at $c_m \sim 0.03$) suggesting the increasing stability of the pentacovalent state. The antimony and bismuth compounds are effectively covalent, but the modes of ionisation of the arsenic and phosphorus compounds have been determined by transport experiments. They are

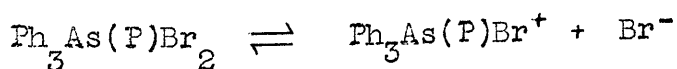
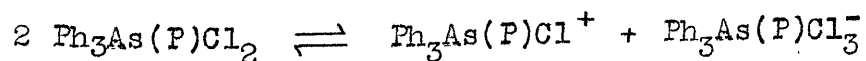

The conductance values for the iodinebromide adducts

antimony compounds causes a slow drift in conductance to higher values.

It is interesting that this type of behaviour is found only among compounds containing M-I bonds. These are much weaker than M-Br or M-Cl bonds (85), and the first step in the disproportionations is believed to be molecular dissociation.

The course of halogen addition to the dihalides in acetonitrile varies greatly, and depends on the nature of the dihalides themselves in this solvent. Halogen (I_2 , IBr or Br_2) addition to the triphenylphosphorus dihalides ($Ph_3PI_{(2-n)}Br_n$), which exist largely as halotriphenylphosphonium halides in acetonitrile, produces tetrahalides $Ph_3PI_{(4-m)}Br_m$. The halogen molecule adds to the halide ion, and the tetrahalides are consequently halotriphenylphosphonium trihalides in acetonitrile. They may also be isolated as unstable crystalline solids. By the same mechanism, halogen (I_2 , IBr or Br_2) addition to triphenylarsenic dibromide in acetonitrile forms three tetrahalides in solution, $Ph_3AsI_{(4-n)}Br_n$ ($n = 4, 3$ or 2). The course of halogen addition to triphenylarsenic diiodide and iodobromide in acetonitrile is more complex than halogen/halide ion addition, since these dihalides are essentially completely disproportionated to triphenylarsine and a triphenylarsenic tetrahalide. Consequently, although the remaining members

of the series $\text{Ph}_3\text{AsI}_{(4-n)}\text{Br}_n$ were indicated conductometrically in acetonitrile, the mobile equilibria and rapid halogen exchange between anion and cation which were set up, made impossible the isolation of $\text{Ph}_3\text{AsI}_3\text{Br}$ from acetonitrile. Finally, however, the compound was isolated from carbon tetrachloride to complete the series of solid tetrahalides.

Halogen (I_2 , IBr or ICl) addition to triphenylarsenic dichloride forms tetrahalides in solution, but these cannot be isolated as crystalline solids. The products obtained were tetraphenylarsonium trihalides, indicating that phenyl migration had occurred.

Of the covalent dihalides, triphenylantimony- and triphenylbismuth dichloride and dibromide do not react with the halogens (I_2 , IBr or Br_2) in acetonitrile, but triphenylantimony diiodide and iodobromide do so on account of the high degree of ionic character of the Sb-I bond. Only two tetrahalides were indicated in solution by conductometric titrations - triphenylantimony tetraiodide ($\text{Ph}_3\text{SbI}_2 + \text{I}_2$), and triphenylantimony triiodobromide ($\text{Ph}_3\text{SbIBr} + \text{I}_2$) - but they cannot be isolated in the solid state. In the former case, tetraphenylstibonium triiodide is formed. In the other additions, ($\text{IBr} + \text{Ph}_3\text{SbIBr}, -\text{I}_2$; $\text{Br}_2 + \text{Ph}_3\text{SbIBr}, -\text{I}_2$) each dihalide is converted to the more stable triphenylantimony dibromide, and the two above-mentioned tetrahalides have been shown to be formed as intermediates in this conversion.

Therefore, it is generally concluded that the driving force of halogen addition to the phosphorus and arsenic dihalides is trihalide ion formation, whereas that of the antimony system is formation of the most stable dihalide. Thus the increasing prevalence of the pentavalent state, with increasing atomic number, is again illustrated.

In the preparation of the tetrahalides in solution, the occurrence of halogen exchange between anion and cation, and anion and halogen molecules has been noted.

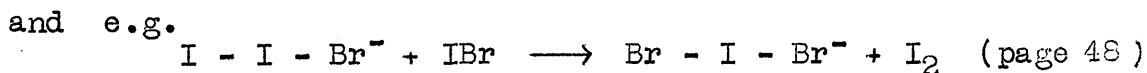
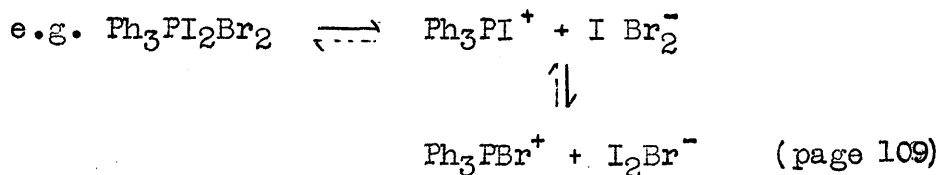

The latter may be explained in terms of the relative stabilities of trihalide ions, and the former in terms of the most favoured mode of ionisation of the tetrahalides. The tetrahalides are all halotriphenyl onium trihalides, and consequently are strong electrolytes in acetonitrile. ($\Lambda_m \sim 100 \text{ ohm}^{-1} \text{ cm}^2 \text{ mole}^{-1}$ at $c_m \sim 0.01$). In the tetrahalides containing only one halogen, the mode of ionisation is unambiguous, but in the tetrainterhalides where ambiguity arises, e.g.

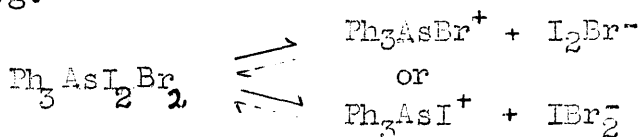

it is controlled by the relative stabilities of the possible cations. The cation stability is presumably directly related to the strength of the M-Hal bond, and the bond dissociation energies of M-Hal bonds in trihaloarsines and phosphines ($P(As)X_3$, X = Cl, Br or I), follow the trend $M-Cl > M-Br > M-I$ (85) suggesting, for example, the trend of cation stabilities $Ph_3AsCl^+ > Ph_3AsBr^+ > Ph_3AsI^+$, and this agrees with the results of the solution studies.

Therefore, it can be stated with certainty that in solution, the mode of ionisation of a triphenylsubstituted Group Vb tetrahalide, is such that the most electronegative halogen atom is incorporated into the cation, and the others form the trihalide anion.

This explains the halogen exchanges between anion and cation noted above. These results for the behaviour of compounds in solution cannot be generally applied to the solid state. Triphenylarsenic diiododibromide does in fact have the same structure in the solid state as in acetonitrile solution, but, for example, the chlorotriphenylarsonium cation present during the formation of, say, triphenylarsenic diiododichloride in solution ($Ph_3AsCl^+ I_2Cl^-$) is not present in the solid isolated from solution, which is $Ph_4As^+ I_2Cl^-$.

The work described in this thesis is considered by the author to represent only an introduction to the study of the

nature of organosubstituted Group V b pentahalides, for while the original aim of the work - to discover the nature of triphenyl-substituted Group V b dihalides and tetrahalides in solution - has been achieved, it seems likely that by using other organic substituents and perhaps fluorine or halogen-fluorides, different modes of ionisation might be found. A comprehensive study would also include primary and secondary substituted derivatives, for there is evidence that they too are ionic, and react with the halogens to form higher halides (Introduction, p.10). Also, many interesting topics - not directly related to the mainstream of the work - have been found, but not extensively studied. These include the formation of triphenylphosphonium halides by halogen addition to triphenylphosphine in moist acetonitrile, the phenyl migration which leads to a simple synthetic route to some tetraphenylarsonium trihalides, and the preparation of compounds of novel stoichiometry - $\text{Ph}_3\text{PI}_{1.5}\text{Br}_{0.5}$, $\text{Ph}_3\text{PI}_{0.67}\text{Br}_{1.33}$, $\text{Ph}_3\text{PH} \cdot \text{I}_{0.33}\text{Br}_{0.67}$ and Ph_4SbI_2 - whose structures would be of great interest.

The most essential follow-up to the main work described, however, must be thermodynamical and kinetic studies of the systems, particularly those in which mobile equilibria are involved, for only in this way will these reactions become fully understood.

APPENDICES.

APPENDIX I.

THE DRY-BOX.

Throughout the research, the transfer of easily hydrolysable materials was carried out in the dry-box. This piece of equipment consisted of a large box (capacity ca. 100 litres) which contained an efficient desiccating agent (phosphorus pentoxide). To eliminate the risk of oxidation of material from the air, the pressure within the box was made slightly greater than atmospheric by passing a stream of dry nitrogen through the box.

The top surface of the box was made of perspex, and the manipulation of apparatus and materials inside the box was carried out through a pair of rubber gloves sealed into the wall of the box. The introduction of apparatus, etc. to the box from the outside and vice versa was achieved through a transfer-box which possessed a double door system.

The interior of the box was therefore isolated from the external atmosphere, and the intrusion of atmospheric moisture was impossible. In this way hygroscopic compounds could be handled in a dry atmosphere without hydrolysing.

APPENDIX 2.

CONDUCTOMETRIC TITRATION APPARATUS.

The apparatus illustrated in fig.13 permits continuous conductometric titrations of anhydrous solutions to be carried out without coming into contact with atmospheric moisture. Also, the solutions do not come into direct contact with tap lubricants.

The procedure employed in a conductometric titration was as follows. Before use the apparatus was baked at 120° for four hours. The titrant of known concentration was prepared in a separate flask. To this, the burette F (capacity 25 cc.) was attached, and filled by gentle application of reduced pressure through tap T₄ (tap T₃ was opened to a system of drying tubes). Tap T₄ was then closed and the burette attached to the main system, which was arranged as shown in the diagram.

Flask C (capacity 50 cc.) initially contained a known volume (ca. 25 cc.) of the solution of known concentration to be titrated. During titration, tap T₃ was permanently closed, and tap T₂ permanently open. Small additions of the titrant were made by opening tap T₄ (the flow of liquid was conveniently "damped" by the very fine constriction E). Complete mixing was ensured by the use of a magnetic stirrer D. To measure the conductance of the solution at each stage

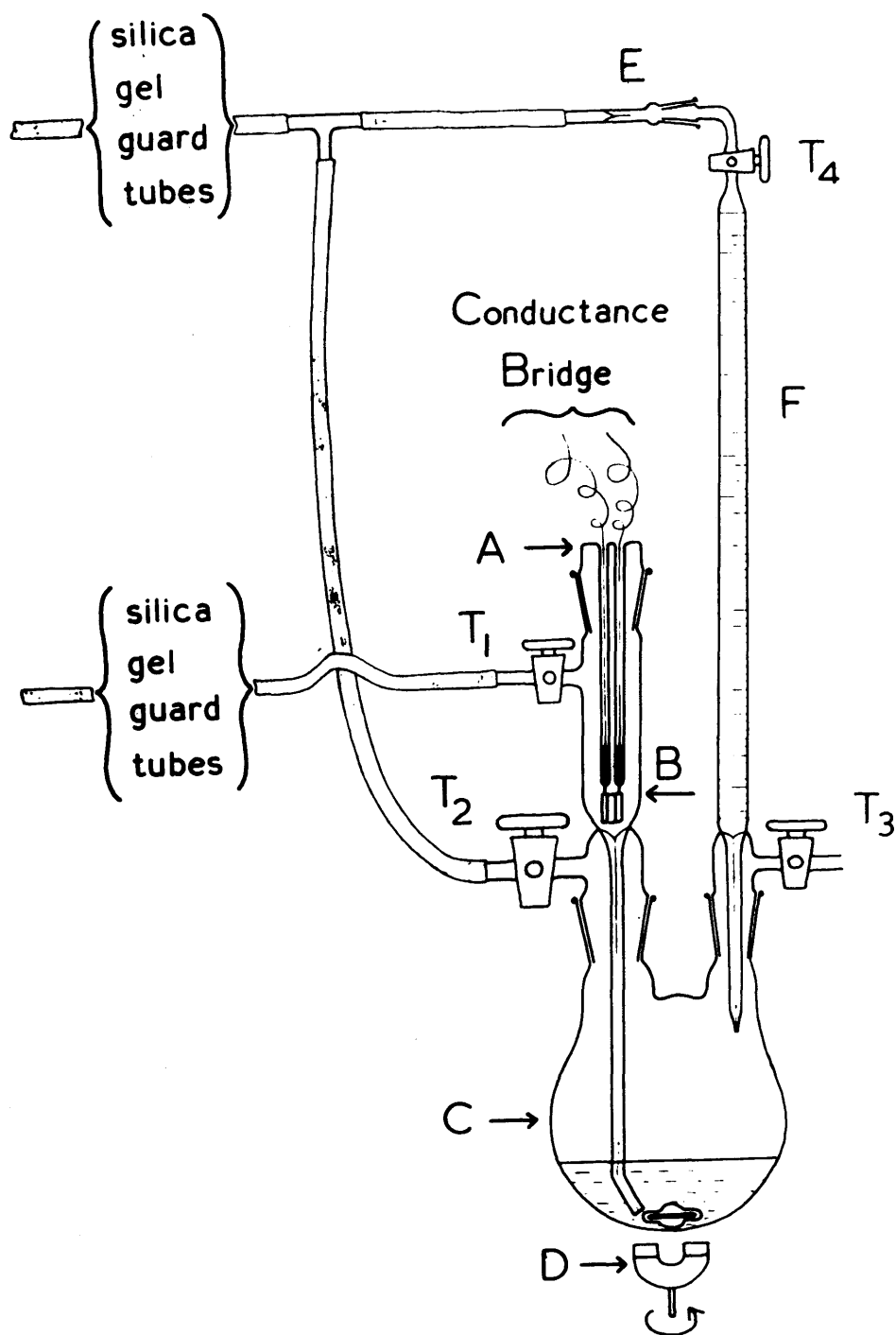

Fig.13. Conductometric Titration Apparatus.

in the titration, a sample was introduced through the capillary tube into the electrode chamber B by gently applying reduced pressure through tap T_1 . The sample was held there by closing T_1 . After noting the conductance, the sample was returned to the titrating flask.

A standard pair of smooth platinum dipping electrodes, A, (see "Conductance measurements", Part 1) were used. The conductance was measured with a Phillips resistance bridge, (GM 4249) when equilibrium had been attained after each addition of the titrant.

APPENDIX 3.

APPARATUS FOR THE DETERMINATION OF TRANSPORT NUMBERS.

The determination of transport numbers by the Hittorf method involves the measurement of small changes in the amount of electrolyte which take place in the solution in the vicinity of the electrodes when the solution is electrolysed. Although the method is straightforward in theory, there are several experimental difficulties to be overcome, and this is reflected in the variety of forms of apparatus described in the literature for the determination of transport numbers by this method.

Since the concentration changes to be measured are usually small, it is important that mixing of the anode and cathode solutions is minimised. Mixing of the solutions within the apparatus may be brought about by diffusion, convection or vibration. Attempts to reduce these errors by, for example, interposing a partition of sintered glass, or lengthening the column of the solution, only results in an increased resistance of the system, and consequently smaller concentration changes. Conversely, attempts to increase the concentration changes by prolonged electrolysis or increased currents, results in an enhancement of the above errors. Therefore, the apparatus must have optimum

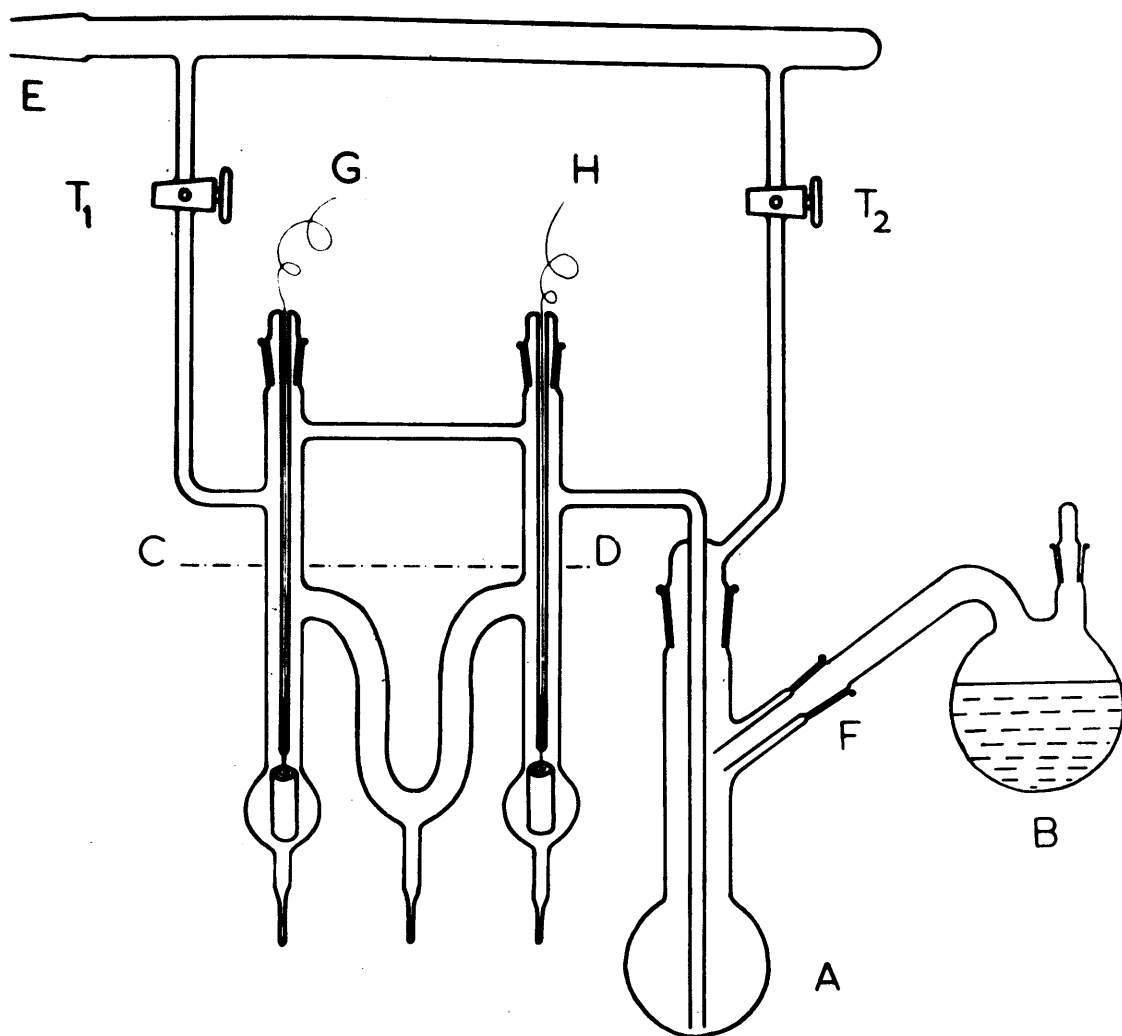

fig. 14. Electrolysis Cell.

dimensions, resulting in a maximum current, with minimum diffusion. Also, contact of anhydrous solutions with tap grease and moisture has been minimised.

The electrolysis cell was of the H- type with a middle (U- shaped) compartment as shown in fig.14. The inner diameter of the tubing was 14 mm. and at each electrode, the width was enlarged. This is reported to reduce the resistance of the filled cell. (86) Instead of using taps to empty each compartment of the cell, fine easily-broken spindles were drawn out. This had the two-fold advantage of eliminating the use of tap grease, and enabling the cell to be immersed in a thermostat, thus dissipating the effect of local heating. The electrodes consisted of smooth platinum foil (coiled) and each had a total surface area of 37.5 cm^2 ; their separation was about 40 cm.

The remainder of the apparatus was designed such that the solutions could be manipulated by pressure difference in a closed circuit. The following procedure was adopted in using the cell.

The apparatus was attached at joint E to the vacuum system, and before use it was flamed out in vacuo. Following this, dry air was allowed into the system. Flask B was then detached and the openings stoppered. The solution to be electrolysed was prepared, and transferred to flask B in

the drybox, and B was rejoined to the apparatus. Taps T_1 and T_2 were closed at this stage, and the main line evacuated. The solution was then transferred to flask A by rotating B about the throughjoint F. The cell was filled by suction to the level C - D (by opening tap T_1) and dry air was then admitted to the system (via the main line) by careful adjustment of taps T_1 and T_2 (after this the delivery tube contained no solution and the pressure above the solution was atmospheric). The H-cell was then immersed in a well stirred thermostat (at room temperature) and the solution electrolysed by the passage of direct current supplied by "Ever-Ready" dry batteries (up to 240 V).

After electrolysis, the compartments were emptied (middle first) and the separate solutions analysed (Part 1, "Methods of Analysis"). The amount of current passed was determined from the increase in weight of a silver coulometer* incorporated in the circuit. A sensitive milliammeter was also included in the circuit, and during electrolysis the current was adjusted to about 1 m.Amp.

* Design of silver coulometer.

A sintered glass crucible (H 3) was placed on a glass tripod in a beaker (150 cc.), and the beaker filled with silver nitrate solution (10%) so that the crucible was about

three-quarters filled with solution. The anode consisted of a cylinder of silver foil interposed between the outer wall of the crucible and the inner wall of the beaker. The cathode was a platinum electrode (area 1 cm²) immersed in the solution within the crucible. The crucible served to trap any silver which became disengaged from the cathode.

The cathode and crucible were weighed before the experiment. After the current had passed, cathode and crucible were washed with distilled water, then acetone, and finally dried in an air oven at 120°. Reweighing enabled the weight of silver deposited to be calculated.

APPENDIX 4.

INFRARED SPECTRA.

The infrared spectra of the halogen adducts prepared in the course of the work have been recorded, and the important features which have emerged are now discussed.

The adducts are all solids, and they were milled with nujol in the drybox immediately after isolation of the compounds. The spectrometers used in the course of the work have been a Perkin-Elmer Direct Ratio Infrared Spectrophotometer, Model 13, Serial 4; a Perkin-Elmer 237 Infrared Spectrophotometer; and a Unicam S.P. 100 double beam Infrared Spectrophotometer, equipped with an S.P.130 sodium chloride prism-grating double monochromator operated under a vacuum.

The abbreviations used in the recording of the spectra are: s, strong; m, medium; w, weak; v, very; br, broad; x, shoulder; () or , split peaks.

1. Triphenylamine-bromine compounds.

Triphenylamine did not react with the halogens in acetonitrile to form dihalides and tetrahalides, like those formed by the other triphenylsubstituted Group Vb elements; the approximate empirical composition of the products from the reaction with bromine were $\text{Ph}_3\text{N}\cdot\text{Br}$ and $\text{Ph}_3\text{N}\cdot\text{Br}_3$. The infrared spectra of these compounds, along with that of

triphenylamine were studied in the hope of elucidating structural details, and are recorded below.

Ph₃N : 1587 m, 1481 s, 1327 m, 1310 w, 1277 s, 1166 w, 1152 w, 1076 w, 1030 w, 1038 w, 747 s, 696 s.

Ph₃N.Br : 1587 m, 1480 s, 1327 m, 1309 w, 1279 s, 1171 w, 1152 w, 1073 m, 1030 w, 1008 w, 894 w, 820 m, 756 s, 696 s.

Ph₃N.Br₃ : 1590 m, 1495 s, 1322 s, 1293 s, 1277 m, 1188 m, 1110 w, 1082 m, 1076 w, 1015 w, 1010 w, 840 w, 825 s, 818 m, 715 w, 720 w, 670 w.

The focal point of interest in these spectra is found to be in the 600-900 cm.⁻¹ region. The triphenylamine absorptions at 747 cm.⁻¹ and 696 cm.⁻¹ are the characteristic C-H out-of-plane deformation frequencies for a monosubstituted benzene (770-730 s, 710-690 s) (87). For Ph₃N.Br the critical absorptions in this region are at 820, 756, and 696 cm.⁻¹. The latter peaks are again those of a monosubstituted benzene, but that at 820 cm.⁻¹ is characteristic of a 1:4 disubstituted benzene (860-800 s). [1:2 disubstituted benzene, 770-735 s; 1:3 disubstituted benzene, 900-860 m, 810-750 s.] (87). That is, Ph₃N.Br is p-bromophenyldiphenylamine. For Ph₃N.Br₃ the occurrence of only one strong bond in this region at 825 cm.⁻¹ shows that the compound is tri-p-bromophenylamine.

2. Triphenylphosphorus Tetrahalides.

The infrared spectra of the triphenylphosphorus tetrahalides from 1600-680 cm^{-1} are recorded in Table 35.

TABLE 35. I.R. spectra of Triphenylphosphorus Tetrahalides.

1	Ph_3PI_4	1580 w	1430 s	1332 w	1310 w	1156 w
2	$\text{Ph}_3\text{PI}_3\text{Br}$	1578 w	1430 s	1334 w	1312 w	1160 w
3	$\text{Ph}_3\text{PI}_2\text{Br}_2$	1583 w	1430 s	1336 w	1310 w	1156 w
4	Ph_3PIBr_3	1585 w	1430 s	1338 w	1312 w	1154 w
5	Ph_3PBr_4	1585 w	1430 s	1340 w	1310 w	1154 w

1	1118 vw	1096 s	1067 w	1026 w	994 m
2	1118 s	1098 s	1069 w	1026 w	994 m
3	1118 s	1098 s	1068 w	1030 w	998 m
4	1118 s	1099 s	1068 w	1032 w	998 m
5	1118 s	1098 s	1069 w	1030 w	1000 m

1	933 w	923 w	836 w	756 m	744 s	720 vs	684 s
2	933 w	920 w	839 w	750 m	738 s	{728, 722 br.vs	684 s
3	(930,	891	832)m.br	750 m	738 ms	726 vs	684 s
4	(930	888	834)m.br	750 m	740 ms	725 vs	691 s
5	(930	888	834)m.br.	750 m	740 ms	724 vs	682 s

The vibrational assignments shown below are made by comparison with the studies of Deacon, Jones and Rogasch (88) on quaternary phosphonium cations, including the tetraphenyl, triphenylmethyl and triphenylethylphosphonium ions.

- ν C - C: 1581 \pm 4, 1430. (a band at ca.1470 is masked by Nujol).
- β C - H: (1336 \pm 4), (1311 \pm 1), 1157 \pm 3, 1068 \pm 1, 1029 \pm 3.
- γ C - H: 830 \pm 940, 735 \pm 760.
- ring breathing: 996 \pm 4.
- ring deformation: 680 \pm 691
- X-sensitive: 1118, 1098 \pm 2.
- X-sensitive: 724 \pm 4.

The ν C-C assignments are C-C stretching modes; the β C-H are C-H in-plane deformation modes; the γ C-H are C-H out-of-plane deformation modes. The X-sensitive modes are planar ring vibrational modes, and are dependent on the nature of the monophenyl substituent. (89) (88). The higher frequency set has been discussed at length by Kross and Fassel (89) who show that it moves to a lower frequency as the electronegativity of the substituent decreases.

In general, the spectra of the $\text{Ph}_3\text{PI}_{(4-n)}\text{Br}_n$ compounds are alike, but there are small but reproducible differences between the spectra of triphenylphosphorus tetraiodide and the other tetrahalides in three regions of the spectrum:

these are the two X-sensitive bands, (1070-1130, 720 ± 10) and the C-H "umbrella" out-of-plane deformation band, ($735-770 \text{ cm}^{-1}$).

In the latter case, the tetraiodide absorbs at 756 cm^{-1} and 744 cm^{-1} , which are higher frequencies than the other tetrahalides. (750 cm^{-1} , $739 \pm 1 \text{ cm}^{-1}$). In the case of the lower X-sensitive band the tetraiodide absorption at 720 cm^{-1} is lower than that of the others ($725 \pm 1 \text{ cm}^{-1}$: split to 728, 722 cm^{-1} in the spectrum of $\text{Ph}_3\text{PI}_3\text{Br}$). The tetraiodide absorption of 1096 cm^{-1} at the higher X-sensitive band is also lower than that of the other tetrahalides (1099 cm^{-1}), and in addition, the peak at 1118 cm^{-1} is very weak in the spectrum of the tetraiodide, but strong in those of the others.

In assigning vibrations it has been assumed that the triphenylphosphorus tetrahalides are halotriphenylphosphonium trihalides in the solid state, and it is suggested that the differences between the tetraiodide spectrum on the one hand and those of the bromine-containing tetrahalides on the other might arise from the different nature of the cation in the two cases, since by analogy with the behaviour of the compounds in solution, the bromine-containing tetrahalides are likely to contain the bromotriphenylphosphonium cation, whereas the tetraiodide contains the iodotriphenylphosphonium cation.

3. Triphenylphosphorus dihalides.

The I.R. spectrum of $\text{Ph}_3\text{PI}_{1.5}\text{Br}_{0.5}$ showed no significant differences from that of Ph_3PI_2 . Both spectra are recorded below, along with that of Ph_3PBr_2 .

Ph_3PI_2 : 1580 w, 1434 s, 1332 w, 1310 w 1178 w, 1164 w,
1152 w, 1118 w, 1096 s, 1070 w, 1026 w 998 m,
974 w, 967 w, 933 w, 843 w, 752 m, 747 s, 740 m,
721 vs, 686 vs.

$\text{Ph}_3\text{PI}_{1.5}\text{Br}_{0.5}$: 1580 w, 1432 vs, 1334 w, 1312 w, 1178 w,
1164 w, 1152 w, 1120 w, 1098 vs, 1072 vw, 1026 w,
996 m, 978 w, 970 w, 933 w, 843 w, 747 vs, 740 s,
721 vs, 688 vs.

Ph_3PBr_2 : 1588 w, 1474 m, 1434 s, 1338 w, 1309 w, 1276 w,
1182 w, 1160 w, 1120 vs, 1033 w, 1008 m, 982 s,
843 w, 782 w, 752 m, 732 vs, 690 vs.

4. Triphenylphosphonium halides.

Initially, the triphenylphosphonium halides were considered, from analyses, to be novel triphenylphosphorus monohalides and their true nature was not discovered until the infrared spectra of these compounds were closely examined.

The spectra are recorded below

Ph_3PHI : 2200 w, 1586 w, 1484 m, 1440 vs, 1150 w, 1118 s,
1105 m, 1071 w, 1029 w, 998 w, 930 m-w, 870 mw,
762 s, 748 m, 738 vs, 725 mw, 715 s, 698 s, 690 s,
680 s.

$\text{Ph}_3\text{PH}\cdot\text{I}_{0.35}\text{Br}_{0.67}$: 2195 w, 1586 w, 1481 m, 1439 vs, 1180 vw,
1160 w, 1120 s, 1105 m, 1070 w, 1029 w, 999 w,
931 w, 871 w, 765 s, 748 w, 738 vs, 722 w, 717 s,
699 s, 681 m.

Ph_3PHBr : 2119 w, 1580 w, 1481 m, 1435 vs, 1325 w, 1310 vw,
1177 w, 1150 w, 1116 vs, 1100 m, 1070 w, 1030 w,
995 w, 980 w, 939 m, 884 mw, 830 w, 762 vs, 748 m,
733 vs, 721 m, 711 vs, 690 s, 680 s.

The assignment of the band at $2100\text{-}2200\text{ cm}^{-1}$ to the P-H stretching frequency was the only feature of the spectrum which unambiguously confirmed that these compounds were triphenylphosphonium salts. (Cross gives ν P-H at $2440\text{-}2350\text{ cm}^{-1}$.) Sheldon and Tyree (73) assign a lone intense band at $1120\text{-}1118\text{ cm}^{-1}$ and two moderately strong bands between 940 and 870 cm^{-1} specifically to triphenylphosphonium salts. These specific assignments, however, are by themselves valueless for unambiguous identification, since similar bands are present in other P-Ph compounds. For example, triphenylphosphorus dibromide has a strong band at 1120 cm^{-1} , and triphenylphosphonium bromide a strong band at 1116 cm^{-1} . By comparison with the results of Deacon et al. (88), the band at $1120\text{-}1118\text{ cm}^{-1}$ is likely to be an X-sensitive mode, and the others ν C-H modes.

In the case of the halides shown above, there is extensive splitting of the bands in the $680-770\text{ cm}^{-1}$ region, which makes their assignment difficult, but could in itself - along with a P-H absorption band and perhaps Sheldon and Tyree's bands - assist in characterising such compounds as substituted phosphonium salts.

The spectrum of $\text{Ph}_3\text{PH}\cdot\text{I}_{0.33}\text{Br}_{0.67}$ sheds no light on the possible structure of the compound.

5. Triphenylarsenic tetrahalides.

The infrared spectra of the triphenylarsenic tetrahalides in the range 1600-680 cm.^{-1} are recorded in Table 36.

TABLE 36. I.R. Spectra of Triphenylarsenic Tetrahalides.

1	Ph_3AsI_4	1570 w	1430 s	1332 w	1308 w	1272 w
2	$\text{Ph}_3\text{AsI}_3\text{Br}$	1570 w	1438 s	1333 w	1308 w	1274 w
3	$\text{Ph}_3\text{AsI}_2\text{Br}_2$	1570 w	1438 s	1330 w	1309 w	1276 vw
4	$\text{Ph}_3\text{AsIBr}_3$	1570 w	1438 s	1332 w	1309 w	1277 w
5	Ph_3AsBr_4	1570 w	1434 s	1332 w	1310 w	1279 vw

1	1178 w	1156 w	-	1072 m	1024 w	994 m
2	1178 w	1158 w	1084 m	1074 m	1022 w	998 m
3	1178 w	1156 w	1084 m	1078 s	1024 w	996 m
4	1179 w	1156 w	1085 m	1079 m	1025 w	996 m
5	1180 w	1155 w	1084 m	1078 s	1022 w	995 m

1	920 w	847 w	840 w	750 m	737 vs	682 s
2	920 w	850 w	839 w	{761 767 m	{748 m 738 vs	684 s
3	918 w	848 w	836 w	763 m	735 vs br	682 s
4	916 w	847 w	838 w	763 m	{754 m 732 vs	682 s
5	916 w	849 w	838 w	763 m	{740 s 735 vs	680 vs

By comparison with the results of Deacon et al., vibrational assignments may be made to many of the bands in the spectra of the triphenylarsenic tetrahalides. Those at 1570 and $1435 \pm 5 \text{ cm}^{-1}$ may be assigned to ν C-C modes; at 1332 ± 2 and $1309 \pm 1 \text{ cm}^{-1}$ probably to β C-H modes; at 1179 ± 1 , 1156 ± 2 and $1024 \pm 2 \text{ cm}^{-1}$ to β C-H modes; at 1084 ± 1 and $1075 \pm 4 \text{ cm}^{-1}$ to X-sensitive modes; at $996 \pm 2 \text{ cm}^{-1}$ to ring breathing; at 918 ± 2 , 848 ± 2 and $838 \pm 2 \text{ cm}^{-1}$ to γ C-H modes; and at $682 \pm 2 \text{ cm}^{-1}$ to ring deformation.

The interest in these spectra - assuming the tetrahalides to be halotriphenylarsonium trihalides in the solid state (see p.57) - is to determine whether there are differences between the spectrum of the tetraiodide ($\text{Ph}_3\text{As I}^+ \text{I}_3^-$) and that of the tetrabromide ($\text{Ph}_3\text{As Br}^+ \text{Br}_3^-$) which could be compared with the spectra of the other tetrahalides of the series, and which might lead to their assignment as bromotriphenylarsonium or iodotriphenylarsonium trihalides.

The two regions of the spectra in which significant changes are observed (Table 36) are the (presumed) X-sensitive band(s) at 1050-1120 cm^{-1} and the γ C-H "umbrella" band at 735 - 760 cm^{-1} . The 1050-1120 cm^{-1} bands are at a lower frequency in the arsenic compounds compared to the phosphorus compounds, and the fact that these frequencies decrease with the increasing atomic number in a periodic group is apparently a general trend related to the partial ionic character of the M-C bond (89).

Like their phosphorus analogues, the spectra of the bromine-containing tetrahalides have a double peak in the 1050-1120 cm^{-1} X-sensitive region, whereas the higher frequency band of the doublet is absent in that of the tetraiodide, which has only a single band occurring at a lower frequency than the corresponding band in the other tetrahalides. The spectrum of the tetraiodide is also distinguished from those of the other compounds by the absence of a medium peak at 763 cm^{-1} (In the spectrum of $\text{Ph}_3\text{AsI}_3\text{Br}$, this is split to 761 and 767 cm^{-1} .) There are no other significant changes which are common to the four bromine-containing tetrahalides, and different from the tetraiodide, but those discussed strongly suggest that the tetraiodide does differ from the others in the solid state. This may be attributed to the different cation, which therefore suggests that the triphenylarsenic tetrahalides which contain bromine are bromotriphenylarsonium trihalides in the solid state as well as in solution. This agrees with the results of the X-ray structural analyses of triphenylarsenic diiododibromide and iodotribromide.

Attempts to detect the As-Br and As-I frequencies in the far-infrared region 500-200 cm^{-1} were unsuccessful, due to poor resolution.

Other spectra recorded are given below.

6. Triphenylarsenic dihalides.

Ph_3AsI_2 : 1580 w, 1489 s, 1440 s, 1335 w, 1315 s, 1282 w,
1167 s, 1172 w, 1080 s, 1030 w, 1050 s, 855 w,
750 s, 738 s, 690 s.

Ph_3AsIBr : 1580 w, 1478 s, 1435 s, 1380 w, 1304 w, 1271 w,
1175 m, 1104 w, 1064 s, 1080 w, 998 vs, 922 w,
834 w, 755 s, 740 vs, 682 vs.

7. Tetraphenylarsonium trihalides.

$\text{Ph}_4\text{AsICl}_2$: 1575 w, 1474 m, 1439 s, 1339 w, 1310 w, 1200 w,
1180 w, 1082 s, 1018 w, 990 m, 920 w, 840 w,
760 m, 741 vs, 735 vs, 680 s.

$\text{Ph}_4\text{AsI}_2\text{Cl}$: 1570 w, 1475 m, 1449 s, 1432 s, 1338 w, 1305 w,
1195 w, 1178 w, 1080 s, 1060 w, 1015 w, 990 s,
920 w, 840 w, 760 vs, 740 vs, 680 vs.

$\text{Ph}_4\text{AsIBrCl}$: 1575 m, 1478 m, 1436 s, 1332 w, 1308 w, 1200 w,
1180 w, 1080 s, 1018 m, 998 m, 920 w, 760 vs,
740 vs, 725 vs, 680 vs.

8. Triphenylantimony dihalides.

Ph_3SbI_2 : 1565 w, 1430 s, 1327 w, 1300 w, 1264 w, 1180 w,
1154 w, 1088 w, 1057 w, 1017 w, 994 m, 960 w,
901 w, 832 w, 724 vs, 682 vs.

Ph_3SbIBr : 1570 w, 1430 s, 1327 w, 1300 w, 1258 w, 1186 w,
1156 w, 1060 w, 1019 w, 994 m, 963 w, 901 w,
726 vs, 682 s.

Ph_3SbBr_2 : 1570 w, 1430 s, 1327 w, 1302 w, 1156 w, 1174 w,
1090 w, 1062 w, 1021 w, 994 m, 901 w, 727 vs, 682 s.

REFERENCES.

R E F E R E N C E S.

1. Challenger, J.Proc.Roy.Inst.Chem., 1945, 105.
2. Cadet, Memoirs de Mathematique et de Physique, 1760, 3, 623.
3. Frankland, Annalen, 1849, 71, 171.
4. Cahours and Riche, Annalen, 1854, 92, 361.
5. Valeur and Gaillot, Compt. rend, 1927, 184, 1559.
ibid. 1927, 185, 779, 956.
6. Lowig and Schweitzer, Annalen, 1850, 75, 315, 327, 355.
7. Béchamp, Compt. rend. 1860, 50, 870.
8. Payne, Quart. Rev., 1961, 15, 173.
9. Rouault, Ann. Phys., 1940, 14, 78.
10. Payne, J., 1953, 1052.
11. Clark, Powell and Wells, J., 1942, 642.
12. Ohlberg, J. Amer. Chem. Soc., 1959, 81, 811.
13. Kolditz and Preiss, Z. anorg. Chem., 1961, 310, 242.
14. Van Driel and MacGillavry, Rec. Trav. Chim., 1943, 62, 167; Powell and Clark, Nature, 1940, 145, 971.
15. Harris and Payne, J., 1956, 4617.
16. Wilson, J. Amer. Chem. Soc., 1958, 80, 1338.
17. Kolditz, Z. anorg. Chem., 1956, 284, 144.
18. Kolditz and Feltz., ibid., 1958, 293, 155.
19. Schlenk and Holtz, Ber., 1916, 49, 603; 1917, 50, 274.
20. Wittig and Rieber, Annalen, 1949, 562, 187.
21. Wittig and Clauss, ibid., 1952, 577, 26.
22. Wittig and Clauss, ibid., 1952, 578, 136.
23. Wittig and Torssell, Acta.Chem.Scand., 1953, 7, 1293.

24. Wheatley, personal communication to Prof.D.W.J.Cruickshank.
25. Wittig and Wheatley, Proc.Chem.Soc., 1962, 251.
26. Rochow, Hurd and Lewis, "The Chemistry of Organo-metallic Compounds", Wiley and Sons Ltd., New York, 1957, ch.8, p.216.
27. van Wazer, "Phosphorus and its compounds", Interscience Publishers Inc., New York 1958. Vol.1, p.263.
28. Kosolapoff, "Organophosphorus Compounds", Wiley and Sons Inc., New York, 1950, p.71.
29. Michaelis and Kohler, Ber., 1876, 9, 519, 1053.
30. Michaelis, Annalen, 1876, 181, 265.
31. Kuchen and Strolenberg, Angew. Chem., 1962, 74, 27-8.
32. Wells, Z.Krist., 1938, 99, 367.
33. Mann, "The Heterocyclic Derivatives of P, As, Sb, Bi and Si", Interscience Publishers Inc., New York, 1950, ps. 66-7.
34. Hantzsch and Hibbert, Ber., 1907, 40, 1508.
35. Lowry and Simons, Ber., 1930, 63, 1595.
36. Jensen, Z. anorg. Chem., 1943, 250, 257.
37. Rochow et al., loc.cit. p.215.
38. Coates, "Organometallic Compounds", Methuen and Co.,Ltd., London, 1960, p.219.
39. Murin and Nefedov, Chem.Abs., 1956, 50, 3915 i.
40. Issleib and Seidel, Z.anorg.Chem., 1956, 288, 201.
41. Mann, J., 1945, 65.
42. Goubeau and Baumgartner, Z. Electrochem., 1960, 64, 598.
43. Douglas, B.Sc. Thesis, Glasgow, 1962.
44. Michaelis, Annalen, 1902, 321, 141.

45. Steinkopf and Schwen, Ber., 1921, 54(B), 1437.
46. Harris, Proc. Chem. Soc., 1961, 65.
47. Hathaway, personal communication to Dr. G.S.Harris.
48. Zingaro and Meyers, J. Inorg. Chem., 1962, 1, 771.
49. Popov and Swenson, J. Amer. Chem. Soc., 1955, 77, 3724.
50. Popov and Skelly, J. Amer. Chem. Soc., 1954, 76, 5309.
51. Hannaway, B.Sc. Thesis, Glasgow, 1961.
52. Adv. Inorg. Chem. Radiochem., 1961, 3, 133.
53. Appleman, J. Phys. Chem., 1961, 65, 325.
54. Ephraim, Ber., 1917, 50, 1069.
55. Mellor, "Comprehensive Treatise on Chemistry", Longmans, Green, New York, 1956. Suppl. II, Part I, pp. 369, 482, 488, 709, 744, 837.
56. Cremer and Duncan, J., 1931, 2243.
57. Cremer and Duncan, J., 1933, 181.
58. McEwan and Sim, personal communication.
59. Smith and Witten, Trans. Faraday Soc., 1951, 47, 1304.
60. Cornog and Karges, Inorganic Syntheses, I, 165.
61. Organic Syntheses, 1950, 30, 96.
62. Parker and Parker, J.Amer.Chem.Soc., 1924, 46, 312.
63. Mitchell, "Sutton's Volumetric Analysis", Churchill, London, 1935, p.256.
64. Grignard and Savard, Compt.rend., 1931, 192, 592.
65. Kalitowska, Roczniki Chem., 1926, 8, 568.
66. Michaelis, Annalen, 1885, 229, 295.

67. Hoffmann, Grunewald and Horner, Ber., 1960, 93, 861.
68. Issleib and Seidel, Ber., 1959, 92, 2681.
69. Rao, Ramachandran and Balasubramanian, Can.J.Chem., 1961, 39, 171.
70. Rydon and Tonge, J., 1956, 3043.
71. Stevenson, B.Sc. Thesis, Glasgow, 1963.
72. Romers and Keulemans, Chem.Abs., 1959, 53, 10892 b.
73. Sheldon and Tyree, J.Amer.Chem.Soc., 1958, 80, 2117.
74. Seyferth, Grim and Read, J.Amer.Chem.Soc., 1960, 82, 1510-1.
75. Michaelis and Rees, Annalen, 1886, 233, 39.
76. Harris, Ph.D. Thesis, Glasgow, 1956, p.22.
77. Popov and Skelly, J.Amer.Chem.Soc., 1955, 77, 3722.
78. Organic Syntheses, Collective Volume 1, p.550.
79. Sharpe, Chem. and Ind., 1958, 1235.
80. Challenger and Allpress, Trans.Chem.Soc., 1915, 107, 16.
81. Inglis, B.Sc. Thesis, Glasgow, 1964.
82. Sidgwick, "Chemical Elements and their Compounds", Oxford 1950, pps. 287, 481, 617, 795, 798.
83. Sanderson, "Chemical Periodicity", Reinhold, New York, 1960, pps. 119, 122, 261 and 273.
84. Cotton and Wilkinson, "Advanced Inorganic Chemistry", Interscience, 1962, pp. 333, 349.
85. Cottrell, "The Strengths of Chemical Bonds", Butterworths, London, 1958. pp.255 - 258.
86. Taylor, "A Treatise on Physical Chemistry", van Norsted Co., New York, 1931. p.682.
87. Cross, "Introduction to Practical Infrared Spectroscopy", Butterworths, London, 1964. 2nd edition, p.65.
88. Deacon, Jones and Rogasch, Aust.J.Chem., 1963, 16, 360.
89. Kross and Fassel, J.Amer.Chem.Soc., 1955, 77, 5856.