

The Heavy Burden of Protein and Energy Malnutrition on the Society of Ghana: Urging the Implementation of an Easily Enacted Backyard Poultry Intervention

Sandra Paola Pedroza Velandia^{1,2}, Katarzyna Kissimova-Skarbek¹

¹ Department of Health Economics and Social Security, Institute of Public Health, Faculty of Health Sciences, Jagiellonian University Medical College, Cracow, Poland

² PATH, Seattle, WA, USA

Address for correspondence: Sandra Paola Pedroza Velandia: pedroza.sp@gmail.com

Katarzyna Kissimova-Skarbek: Instytut Zdrowia Publicznego, Grzegorzeczka 20, 31-531 Kraków, kskarbek@uj.edu.pl

Abstract

Background. Stunting hinders the development of children around the world.

Objectives. We have calculated the burden of disease attributable to protein and energy malnutrition (PEM) in Ghana and evaluated the impact of the modelled intervention to prevent stunting in Ghana.

Methods. A literature review was conducted to better understand the economic implications of stunting. The burden of PEM was measured in Disability-Adjusted Life Years (DALYs) and income lost. A culturally sensitive nutritional intervention was designed to prevent stunting in the target population. The comparator was no intervention. We performed cost-effectiveness, cost-utility, and cost-benefit analyses.

Results. The estimated income lost due to PEM in Ghana was over 70 bln 2014 international dollars (I\$). In 2014 the Ghana GDP per capita was I\$4,548.00. The incremental cost-effectiveness ratio (ICER) per stunting case averted was I\$2,573.72. The ICER per DALY averted was I\$896.18. The cost-benefit ratio was 0.03.

Conclusion. Stunting causes a high burden to society in Ghana. The modelled backyard poultry intervention is very cost-effective in reducing stunting and its effects.

Key words: stunting, burden of disease, DALY, Ghana, cost-effectiveness analysis, cost-utility analysis, cost-benefit analysis, backyard poultry

Słowa kluczowe: karłowatość, obciążenie chorobą, DALY, Ghana, analiza kosztów i efektów, analiza kosztów i użyteczności, analiza kosztów i korzyści, drób przydomowy



Ministerstwo Nauki
i Szkolnictwa Wyższego

Przygotowanie i edycja anglojęzycznych wersji publikacji finansowane w ramach umowy 914/P-DUN/2016 ze środków Ministra Nauki i Szkolnictwa Wyższego przeznaczonych na działalność upowszechniającą naukę.

Introduction

Malnutrition refers to both overnutrition and undernutrition [1]. Overnutrition, mistakenly thought as a health problem of high-income countries, also affects low and middle-income countries. There is robust evidence supporting the ever growing prevalence of overnutrition in both developed and developing countries. The increased prevalence of overnutrition contributes

to an increase of non-communicable diseases such as diabetes and ischemic heart disease [2]. However, undernutrition is still highly prevalent in many middle and low-income countries. The United Kingdom Department of Development went as far as to call undernutrition ‘a scourge in our world’ [3]. The focus of this study is on undernutrition because, despite all the efforts made by the international community to alleviate it and its effects, there is still much work to be done to eradi-

cate it. Undernutrition hinders the ability of individuals as well as of entire societies and countries to reach their full potential.

Undernutrition, as defined by UNICEF, is the outcome of insufficient food intake and repeated infectious diseases [4]. The three forms of undernutrition are micronutrient deficiencies, wasting, and stunting [4]. Micronutrient deficiencies refer to deficiencies in vitamins and minerals such as vitamin A, B₁₂, and Iron [4]. Wasting is defined as being dangerously underweight for one's height [4]. Stunting is defined as being too short for one's age [4].

Ghana is a country located in the western part of sub-Saharan Africa. In 2013 it had a population of 26,164,432 according to the UN Population Division [5]. In the year 2014 348 infants per thousand, between twenty four and thirty six months old, were stunted in the country [6]. This indicates that more than one third of the children in Ghana are not currently developing to their full potential. This prompted the authors to conduct a study focused on the economic burden of PEM and its consequence – stunting. More specifically, we consider stunting the result of chronic deficiencies in the complex interactions between household food security, appropriate care, health conditions and appropriate health systems [7]. We also assessed nutrition specific prevention intervention which was modelled and evaluated following the economic evaluation principles.

Recent studies have identified stunting as an underlying factor of low productivity in both individuals and societies [3]. Stunted children will grow up to be stunted adults. Stunting growth prevents individuals from reaching their full potential and therefore they do not contribute to their communities as much as they could have if they had not been stunted. It is important to clarify the difference between short stature and stunting [8]. Short stature is attributed to genetic factors. Having short stature is by no means related to lower cognitive skills. On the contrary, stunting is atrophied physical and cognitive development as a result of the complex interactions between humans and their environment.

The consequences of stunting can be easily overlooked because stunted children do not suffer from any obvious or painful symptoms. Stunted children often appear to be healthy but in reality they are too short for their age, hindering their ability to fully develop to their full potential [8]. Children are considered stunted when they have a height-for-age z-score (HAZ) that is more than two standard deviations below the age-sex median for well-nourished reference populations [3]. Children are usually classified as stunted at the age of 2 – when it is already too late. Studies show that it is virtually impossible for children diagnosed as stunted by age 2 to develop to their full physical and cognitive potential later in life. Stunting cannot be cured; it can only be prevented during the first 1,000 days of life – beginning at gestation and until two years of age. This time frame is called *the window of opportunity*. Evidence shows that preventing stunting will have a positive impact on individual and societal development.

Methodology

A systematic review was performed to understand the burden of stunting from an economic point of view also using Global Burden of Disease (GBD) study methodology. The modelled, easily enacted, backyard poultry malnutrition prevention intervention was evaluated using an economic evaluation of the program's principles. Three main types of economic analyses were performed for this project: (i) Cost-Effectiveness Analysis (CEA) was performed using change in mortality and stunting rates pre- and post- intervention as effects of the intervention. (ii) In the Cost-Utility Analysis (CUA) the outcome was a number of reduced DALY's due to premature death caused by stunting. (iii) A Cost-Benefit Analysis (CBA) was performed using the human capital approach. The benefits from the intervention took into consideration a change in future earnings, consumption and GDP. The comparator of the CEA, CUA and CBA was NO intervention (the present standard of care).

Systematic search strategy

The literature review search was initially conducted on PubMed. Subsequently specialized databases like POPLINE (Population Information Online), Wiley Online Library, and the Lancet Database website were also used. The initial search terms were defined as *economic evaluations AND children AND stunting*. After the identification of the first articles, a snowball technique was used to identify other articles and authors working within the same area of knowledge. The search was conducted on September 9, 2016. The inclusion criterion was defined as reviews and economic evaluations looking specifically at the economic consequences of stunting. Only articles published from 2007 until 2016 in English were considered for this review.

After the inclusion and exclusion criterion were applied, seven papers were identified. The papers were divided in two groups. The first group is composed of four papers that highlight the lack of cost-effectiveness evidence regarding nutritional interventions [10]. This group also underlines the developmental potential during the first five years of life, especially in developing countries [11] and finally it explains the rationale for investing in reducing stunting [3]. The second group is composed of three papers that illustrate economic evaluations performed in nutrition interventions around the world. Two economic evaluation studies have been performed regarding nutrition specific intervention in Pakistan [12, 13]. The last paper evaluates the economic consequences of a nutritional complementary intervention in Guatemala [14].

Burden of disease

Burden of disease may be measured with various indicators like: the number of deaths caused by the disease, the number of cases of the disease, years of life lost due to disease, both: (i) without counting reduction in health-

related quality of life or (ii) with consideration of disability caused by the disease like the Disability-Adjusted Life Years (DALY) measurement. The disease also has consequences on patients' and their families' ability to work and earn an income, the opportunities for education and career development, and on the society as a whole – production lost and reduced economic growth. In this study we focus on DALYs and income lost due to premature deaths and disabilities caused by PEM.

Within the GBD study, since the beginning of 1990s the burden of disease has been calculated to determine which diseases are contributing the most to morbidity and mortality rates in a particular country, region or globally [9]. The latest Global Burden of Disease (GBD) methodology came out in 2015. It excludes age weighting in DALYs. It uses equal standard life expectancy at birth for both males and females and does not discount the time lived with disability. Burden of disease studies are used to inform evidence-based policymaking processes and to support allocation of resources targeting those diseases causing the most DALYs.

The burden of disease attributable to stunting was calculated using protein and energy malnutrition (PEM), morbidity and mortality rates as proxy variables to calculate DALYs. The economic value of a year of healthy life lost due to PEM was measured using a method employed by the WHO Commission on Macroeconomics and Health (CMH), which makes an assumption that each DALY can be valued at between one and three annual GDP per capita for the country being studied.

Modelled intervention

Intervention design

Eight hypothetical communities representative of the Ghanaian population were modelled to evaluate the community based backyard poultry intervention in rural Ghana, based on the work of Heifer International. Heifer International is an international non-governmental organization (NGO) that has a “teach a man to fish” philosophy [15]. One of their main activities is providing farmers with livestock, as well as training, to improve food and nutrition security [16].

For this hypothetical intervention, an NGO similar to Heifer International considers providing four communities with the necessary livestock to provide sustainable animal source protein to children between six and twenty four months of age. The organization is interested in providing this group of children with supplementary animal source protein because scientific literature indicates that adequate nutrition during this critical development period – *the window of opportunity* – has remarkable developmental consequences that stay with children and their communities for the rest of their lives [17]. On the contrary, the lack of adequate nutrition during this period can lead to serious developmental consequences that will affect children and their communities in the short and long

run. The NGO decides to test the hypothesis that protein supplementation during the *window of opportunity* leads to healthier, more productive individuals and societies. For this reason eight communities of 10,000 inhabitants each were modelled. The communities are representative of the population in Ghana. Staying on track with the sustainability trend, the NGO decides to provide layer hens to four out of eight-modelled communities. Layer hens provide a constant supply of eggs, an excellent animal source protein, at low cost to the environment and the investors. Layer hens also require very little care, allowing communities to pursue other activities while enjoying the benefits of having layer hens in the community. We decided to test our hypothesis by performing an economic evaluation of the intervention from the perspective of the payer for the cost and from a broad societal perspective for the outcomes.

The duration of the intervention will only be 18 months. The start-up period of the intervention is only 2 weeks long. It begins with the hiring of a regional coordinator. The regional coordinator is responsible for recruiting three field workers per community who will be responsible for recruiting five volunteers each, preferably women. Once the recruitment is finalized the regional coordination will be responsible for providing the field workers with the materials and feed needed to successfully run a community based backyard poultry intervention. Once the field workers have identified the volunteers who will help them run the chicken coops they will train them on basic fowl rearing practices. Part of the training is building and preparing the chicken coop for the arrival of the layer hens. During training volunteers agree to protect the layer hens and not eat them until they have completed their egg-laying phase. Once the hens have arrived in each community they are distributed to their corresponding chicken coop by the regional coordinator. The start-up period is over when the layer hens are delivered to their assigned chicken coops.

The post-start up period is 96 weeks long. Layer hens will grow and develop during the first twenty weeks of the post-start up period. During this time the field workers will coordinate and schedule the volunteers to feed, clean, and maintain the chicken coops. They will also ensure that households with children in the 6 to 24 month age range are aware of the intervention and are encouraged to participate in it. Making sure the fowl and the communities are protected from zoonotic diseases is very important to the NGO. Therefore, the regional coordinator is required to provide the field workers with the necessary vaccines to keep the chickens safe. The necessary vaccines are *new castle, the fowl pox, and infectious bursal disease*. They will be administered to the fowl according to the Food and Agriculture Organization of the United Nations (FAO) recommendations. Once the hens start laying eggs the volunteers will distribute the produced eggs to families members in the community with children between six and twenty four months of age. This phase will last 76 weeks. This is the usual egg-laying period of hens.

Figure 1. Linear Interpolation. Number of babies still alive at age x

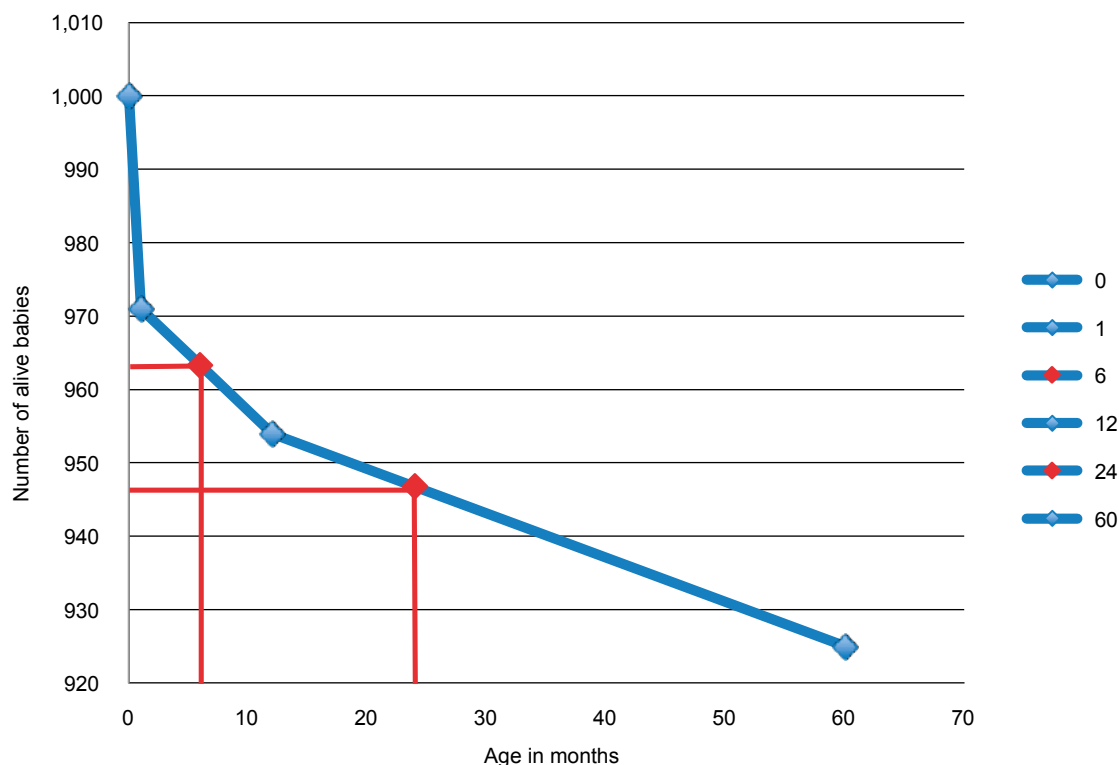

Source: Authors' elaboration.

Sample size

The sample size was calculated by applying the crude birth rate in Ghana to a population of 10,000 people. The number of newborns, in four communities of 10,000 people each, was calculated using linear interpolation as well as the number of infants that would be between six and twenty four months of age in the community.

Linear interpolation to calculate mortality rates at age 6 and 24 months

Linear interpolation was used to calculate the unknown mortality rates at 6 and 24 months. Knowing the infant mortality rates at 6 and 24 months allowed the authors to estimate with more precision the number of infants in the modelled intervention that are within the age group of interest. It would be wrong to say that all the 1,000 newborns make it to 6 months because in real life not all newborns do so. Drawing similar triangles under the curve and interpolating the missing values served to calculate the unknown infant mortality rates. In linear interpolation a function is created from observational data points by drawing straight lines from each known point to the next. This function can then be evaluated at any point of interest to determine an approximate value. In other words, having this function allows the authors to insert any value in it (e.g. months) and determine how many babies are still thriving. Thanks to these techniques we were able to estimate that the population of infants

between six and twenty four months in these four communities was 1,756 children. Assuming a conservative approach, 90% of the target population would participate in the intervention, meaning a total of 1,581 children. The graphical explanation of linear interpolation and the drawn triangles can be observed in Figure 1.

Although eight identical communities were modelled, only infants from four of the communities would participate in the intervention in order to have both control and intervention groups. All the infants in this age interval are eligible to participate.

Cost of the intervention

As mentioned above, the goal of this study is to evaluate the economic impact of a community based backyard poultry intervention that increases access to protein for infants (between 6 to 24 months) in the four intervention communities. The protein is available in the form of a daily egg per child. The first part of the intervention will last a total of eighteen months. During the intervention period 2,219 hens produce a total of 865,454 eggs. The hens chosen for the intervention produce between 250 to 270 eggs a year. For this model the average egg production per hen is 260 eggs per year, a total of 390 eggs per hen during the intervention period.

The costs of the intervention were only approached from the perspective of the payer while the impact of the intervention took a broader societal perspective. Unit costs were obtained from experts in the field and from

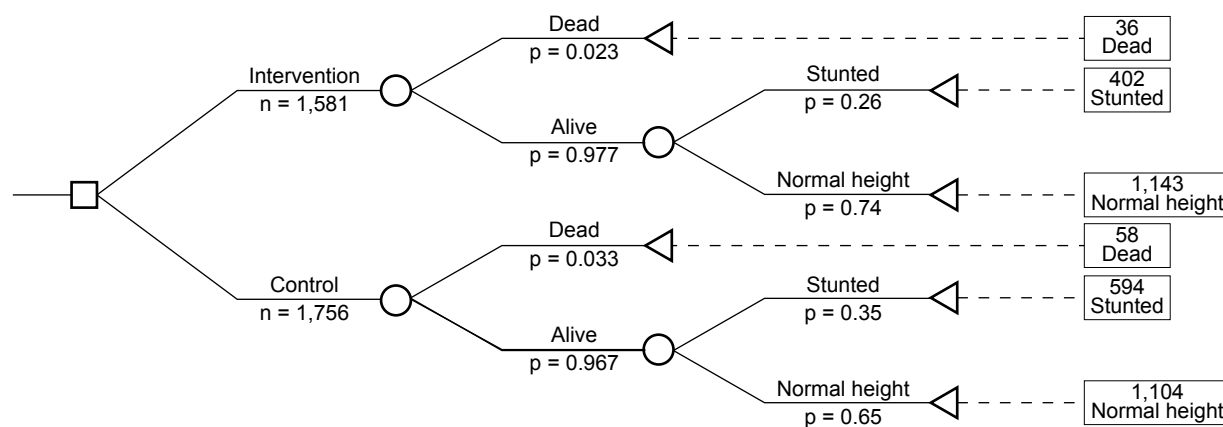
Figure 2. Decision Tree (From 6 to 24 months of age)

Source: Authors' elaboration based on the data from INCAP study.

Food and Agriculture Organization of the United Nations publications about backyard poultry in Ghana. Most of the values were from 2014. However, when cost and benefit data were available for earlier years than 2014 – the values were converted to 2014 international dollars (I\$) using Ghana CPI and the National Currency (Cedi) per the US dollar conversion factor (Purchasing Power Parities for GDP).

Outcomes of the intervention

The impact of the intervention was extrapolated from a study performed by the Institute of Nutrition of Central America and Panama (INCAP) in Guatemala from 1969 to 1977. The variables considered for the cost-effectiveness analysis were mortality and stunting rates. DALYs reduced were considered for the cost-utility analysis (with 0% and 3% discount rates applied). The human capital approach was taken for the cost-benefit analysis. A sensitivity analysis was also performed as part of the cost-benefit analysis using 3%, 5%, and 7% discount rates.

Economic evaluation of the intervention

Economic evaluations are rarely conducted on nutrition interventions. Aware of the lack of similar studies, the authors have taken an organic approach to this project, embracing the flexibility to economically evaluate as much or as little as possible with the available data.

Cost-Effectiveness Analysis

For this part of the analysis a decision tree was built to illustrate the different outcomes (the number of deaths and persons still alive and the number of stunted and non-stunted) from the intervention and the control group. Due to the complexity of this evaluation the tree only includes short-term outcomes of the intervention such as the probability of dying or of being stunted by the 24th month. The decision tree was a way to illustrate the different size of

the intervention and control groups. The difference is due to the intervention coverage. In order to be conservative, the authors modelled an intervention with only 90% coverage to reflect the coverage rate of similar interventions. The decision tree also illustrates the transitional probabilities of mortality and stunting. The path probability of being stunted at the age of 24 months for children still alive in the intervention is 0.254 (0.977×0.26), while the path probability of having normal height for children in the intervention group is 0.723 (0.977×0.74). On the other hand the path probability of being stunted by 24 months in the control group is 0.338 (0.967×0.35). The path probability of having normal height at the age of 24 months in the control group is 0.629 (0.967×0.65). The decision tree created for this intervention can be seen in **Figure 2**.

Using reduction in mortality rate as an effect of intervention

In order to calculate the cost-effectiveness of the intervention on the total number of deaths averted by the modelled community based backyard poultry intervention the total cost of the intervention was calculated in 2014 international dollars. The total cost of standard of care from the perspective of the payer is negligible because the payer does not currently have an intervention in place. The incremental cost therefore is equal to the total cost of the intervention. The incremental effectiveness of the intervention was calculated by subtracting the deaths that were averted with the standard of care from the deaths prevented due to the intervention. The incremental cost-effectiveness ratio was calculated by dividing the incremental cost by the incremental effectiveness. The results from the incremental cost-effectiveness ratio were compared to the Ghana's GDP per capita for the year 2014.

Using reduction in stunting rates as an effect of intervention

In order to calculate the cost-effectiveness of the intervention on the total number of stunting cases averted by the community based backyard poultry intervention,

the total cost of the intervention was calculated in 2014 international dollars. The incremental effectiveness of the intervention was calculated by subtracting the number of stunting cases averted with the standard care from the stunting cases prevented due to the intervention. The incremental cost-effectiveness ratio was calculated by dividing the incremental cost by the incremental effectiveness.

Cost-Utility Analysis

To identify the cost-utility of the community based backyard poultry intervention the DALYs averted were calculated. Estimating DALYs due to stunting is not a straightforward task. In fact it was nearly impossible to find disability weights for stunting in the literature that truly reflect the magnitude of the devastating consequences of stunting in the futures of children around the world. With this in mind only DALYs due to premature death were considered for this work. Unfortunately, death is only the tip of the iceberg [11] when evaluating the consequences of poor nutrition in the lives and futures of children around the world. Therefore the DALYs calculated in this work are highly underestimated. The total DALYs attributed to premature mortality due to inadequate food intake averted with the intervention was calculated using the Global Burden of Disease Study 2010 methodology [18]. The DALYs averted were not age-weighted, were only discounted and a new standard life expectancy at average age of death for both sexes (1.25 year) was used. The version of DALYs averted using national life expectancy at age of death in Ghana was also assessed with data from the WHO [19]. The incremental utility of the intervention was calculated by subtracting the number of DALYs averted with the standard care from the DALYs averted with the intervention. The incremental cost utility ratio was calculated by dividing the incremental cost by the incremental utility of the intervention. The results from the incremental cost utility ratio were compared to the Ghana's GDP per capita for the year 2014 in international dollars in order to decide if the intervention is cost-effective.

Cost-Benefit Analysis

To perform the cost-benefit analysis the human capital approach was taken to evaluate the long-term impact of the intervention. The impact of the intervention in mortality and stunting rates was considered to calculate the population that would be able to join the work force. The GDP per capita in PPP terms was used as a proxy variable to measure the per capita consumption between the years 2039 and 2059 by the children in the eight communities modelled for this study. By the year 2039 infants in the intervention group would be 25 years old and most of them would be in the work force according to Ghana's statistics [6]. The model assumes that people in Ghana are only part of the work force between the ages of 25 and 50. The number of surviving adults was calculated using Ghana's adult mortality rate [6]. GDP per capita in PPP terms was projected for the next forty-five years assuming participants in the intervention would be in the work force for twenty-five years. The per capita consumption of stunted adults compared to normal height adults was calculated using Hoddinott et al.'s results [20]. Hoddinott et al. found strong evidence supporting the theory that the multiple damaging effects of growth failure in early childhood persist into adulthood [20]. Some of the effects of stunting in adulthood are lower cognitive scores, a lower level of per capita consumption and a higher probability of encountering poverty among others. The Hoddinott et al. model predicts that stunting reduces per capita consumption by an immense 66% [20]. Stunting has such a high costs because it has a large impact on cognitive skills [20]. Cognitive skills usually determine the number of years of schooling and in turn they have high returns in the labor market [20]. A summary of the methodology used to calculate the human capital approach of this intervention in the intervention group can be seen in **Table I**. The exact same methodology was used to calculate the human capital losses attributable to stunting in the control group.

The total benefit for the standard of care was calculated considering the number of stunted and normal

Table I. Sample of the methodology used to calculate the human capital losses attributable to stunting

Intervention (6–24 months of age) n = 1,756								
Year	Age	Work force participation rate (%)	Adult mortality rate (%)	People in the work force		Total GDP if there was no difference in consumption (IS)	Total GDP of stunted and normal adults (IS)	Loss in GDP from stunted adults (66% less) (IS)
				Stunted adults	Normal adults			
2039	25–29	86.95	25.1	300	821	16,578,694.20	13,646,368.11	2,932,326.16
2044	30–34	92.30	25.1	319	871	22,760,549.85	18,734,819.32	4,025,730.53
2049	35–39	94.40	25.1	326	891	30,106,020.62	24,781,073.41	5,324,947.21
2054	40–44	95.50	25.1	331	904	39,493,030.00	32,507,772.72	6,985,257.28
2059	45–49	95.00	25.1	328	897	50,676,380.66	41,713,088.73	8,963,291.93
					Total	159,614,675.40	131,383,122.29	28,231,553.10

Source: Authors' elaboration.

Box 1. *Formulas for indicators used in cost-benefit analysis*

$$\text{Incremental Benefit} = \text{TB}_{\text{intervention}} - \text{TB}_{\text{control}}$$

$$\text{NetBenefit} = \text{Incremental Benefit} - \text{Costs of Intervention}$$

$$\text{Incremental Cost Benefit Ratio} = \frac{\text{Costs of Intervention}}{\text{Incremental Benefit}}$$

Where: $\text{TB}_{\text{intervention}}$ – Total benefit achieved within the intervention group
 $\text{TB}_{\text{control}}$ – Total benefit achieved within the control group

Source: Authors' elaboration.

height adults from the original number of children in the control group. The total benefit for the intervention group was calculated considering the number of adults from the number of children in the intervention group (90%) plus the children who were not covered by the intervention (10%). The incremental benefit was calculated by subtracting the total benefit achieved within the control group from the total benefit gained by the intervention group. The net benefit was calculated by subtracting the total cost of the intervention from the incremental benefit of the intervention. The incremental cost benefit ratio was calculated by dividing the cost of the intervention by the incremental benefit of the intervention (See **Box 1**). In order to present the value of a future stream of benefits in terms of their present day value, a discounting procedure was applied and a sensitivity analysis was performed using 3%, 5%, and 7% discount rates.

Results

Literature review findings

Batura et al. [10] looked at 15 articles to assess the cost-effectiveness of early childhood nutrition and development (ECND) in a target population of children under five years of age. Unfortunately, Batura et al. [10] discovered that despite the vast evidence in the literature of the impact of ECND interventions in improving children's developmental outcomes, very few economic evaluations are performed on interventions of this nature [10]. The variability of the elements considered when performing the cost-effectiveness analysis makes it very hard to compare the results of the different cost-effectiveness studies. Some of the studies looked at stunting cases averted, others looked at number of deaths averted, while some others looked at DALYs reduced by the intervention [10]. Out of the 15 cost-effectiveness studies evaluated by Batura et al. only three pairs used the same outcome measurement variable [10]. The three common denominators used were DALYs, cases of stunting averted, and Eyberg Intensity Scores, forcing Batura et al. to only compare the pairs of articles that used the same common denominator [10]. Authors emphasized the need to enable comparisons between cost-effectiveness articles evaluating ECND

to generate strong evidence in favor of allocating monetary resources to interventions that impact ECND [10].

Grantham-McGregor et al. emphasized the importance of helping children under the age of five in low and middle-income countries to thrive [11]. They examined all the factors that can potentially lead to stunting and connected them with their economic consequences. The authors drew data from cross-sectional studies in Tanzania, Nepal, and Ghana [11]. They found out that stunted children were more likely to enroll late in school. Stunted children in Tanzania were less likely to be enrolled in school than non-stunted children. In the same paper, Grantham-McGregor et al. found that stunted students in countries like Nepal [21], China [22], Jamaica [6, 23], India [24], the Philippines [25–27], Malaysia [28], Vietnam [29], Brazil [30], Turkey [31], Guatemala [32] (only boys) attain lower achievement levels or grades for their age [33]. Grantham-McGregor et al. also found four published longitudinal studies linking early stunting with lower cognition and school grades later in life [11]. They present a study in Jamaica in which stunting before 24 months was linked to school dropout rates at 1 to 18 years of age [23]. Using data from previous studies in Guatemala [34] the authors discovered that being stunted at 36 months was related to cognition, literacy, numeracy, and general knowledge in late adolescence. Children who do not reach their developmental potential are less likely to be productive adults because either their educational attainments are low or they learn less per year of schooling [11]. The lack of optimal education attainment during childhood has repercussions on the labor market. In the same review Grantham-McGregor et al. used data from Indonesia [35] to show that on average, each year of schooling increases wages by 7–11%. They concluded that the loss of human potential is associated with more than a 20% deficit in adult income and that it has implications for the development of societies and entire nations [11].

In a review performed by Hoddinott et al. clear examples are given of the many ways stunting is limiting the development of children and societies around the world [3]. The findings from Hoddinott et al. align with the previously described statistics. Stunted children attain less education than non-stunted children, which leads to them earning less money later in life in the labor market [3]. In a different paper, Hoddinott et al. found that children stunted at 36 months grow up into stunted adults who have 66% lower per capita consumption than non-stunted adults [20]. In the review Hoddinott et al. calculated the benefit-cost ratios for investments in nutrition specific intervention to eliminate stunting in seventeen selected high-burden countries [3]. For instance, they calculated that for every dollar invested in reducing stunting in Bangladesh, the economic return is estimated to be \$1.9 – \$18.4 [3]. The Bangladesh benefit-cost ratio was the median value of all of the seventeen benefit-cost ratios calculated by Hoddinott et al [3].

In 2008 Victora et al. also looked at the adult and human capital consequences of maternal and child under-nutrition [36]. The authors found that height not attained during the first two years of life is impossible to regain

Table II. Papers on the economic consequences of nutritional interventions

Paper	Author	Year	Target population	Paper type	Baseline indicators	Economic indicators
Highlighting the evidence gap: how cost-effective are interventions to improve early childhood nutrition and development?	Batura Neha et al. [10]	2014	Under 5	Review	N/A	<ul style="list-style-type: none"> • DALY • Cost per death averted
Developmental potential in the first 5 years for children in developing countries	Grantham-McGregor Sally et al. [11]	2007	Under 5	Review	<ul style="list-style-type: none"> • Prevalence of stunting • Number of people living in absolute poverty 	<ul style="list-style-type: none"> • National development • Educational attainment
Maternal and child undernutrition: consequences for adult health and human capital	Victora Cesat et al. [36]	2008	Mothers and children	Review	<ul style="list-style-type: none"> • Prevalence of stunting • Undernutrition 	<ul style="list-style-type: none"> • Human Capital • Salary
Adult consequences of growth failure in early childhood	Hoddinott John et al. [37]	2013	Under 5	Economic evaluation	<ul style="list-style-type: none"> • Prevalence of stunting • Undernutrition 	<ul style="list-style-type: none"> • Educational achievement • Age at first birth • Household wealth index score • Household expenditure and poverty

Source: Authors' elaboration.

later in life [36]. In agreement with the findings from previous articles Victora et al. found that child growth is related to educational attainment in Zimbabwe [36]. Although around the world females salaries are lower than males salaries, the authors found a decrease of 8% salary in Brazilian stunted women and a 25% decrease in salary in Guatemalan women [36]. An additional review by Hoddinott et al. estimated that stunted adults have a higher probability of living in poverty by 42 percentage points than non-stunted adults [37]. The results from the first part of the systematic review are illustrated in **Table II**.

Guatemala Intervention

This retrospective economic evaluation looks at the economic productivity of stunted adults versus the economic productivity of non-stunted adults. Hoddinott et al. assessed the average income of adults who 25 years earlier had participated in a supplementary nutrition intervention [14]. Half of the cohort had access to a gruel high in protein – *atole* and the other half had access to fruit flavored water – *fresco* [38]. Hoddinott et al. focused on children who participated in the intervention from birth until they turned three years old [14] because they found that exposure to *atole* before 3 years of age significantly raised wage rates by US\$0.62–\$0.67 per hour [14]. The wage rate increase represented a 46% rise above average wages in the sample [14]. It's important to mention that this was only significant for this age group. There was no relationship between children who were exposed to *atole* after 36 months and their adult wages [14]. The income increase was only significant for men; contrary to previously mentioned

findings, exposure to *atole* was not related to higher salaries in women. This statistic can be explained by cultural factors. Women represent a smaller portion of the work force in Latin American countries. Hoddinott et al. argued that in several countries women mostly engage in non-remunerated activities such as caring for future and older generations [14]. In addition to the economic gains, Hoddinott et al. found that high protein gruel supplementation for 24 months increased schooling by 1.2 grades in both genders [14]. In fact, it increased reading comprehension and performance in the Raven's test of progressive matrices by about 1% in males and 8% in females [14].

Pakistan Interventions

Two economic evaluations were found of interventions performed in this context. One of them was a cost-effectiveness analysis of responsive stimulation and nutrition interventions on childhood development by Gowani et al. [12]. This cost-effectiveness analysis contrasted a nutrition specific intervention to an intervention incorporating children responsive stimulation [12]. Gowani et al. also commented on the lack of economic evaluations on nutrition interventions [12]. Gowani et al. mentioned the challenges of conducting cost-effectiveness analyses on interventions that have several outcomes [12] as is often the case with interventions of this type [12]. The authors argued that cost-effectiveness analysis needs to be performed more frequently on nutrition specific interventions to increase the existing literature on cost and economic consequences of nutrition interventions [12]. They found that children who receive responsive stimulation in addition to a nutritional intervention had sig-

nificantly better outcomes at 24 months than those who only received the nutritional intervention [12]. Although the results from this study are not favorable to nutrition specific intervention, this study contributed towards the development of evidence based policy.

The second economic evaluation performed in the Pakistani context was done on a hypothetical intervention of micronutrient sprinkles. For the purpose of this economic evaluation Sharieff et al. modelled two communities representative of the Pakistani population [13]. They had high infant mortality rates, a high prevalence of anaemia, and a high longitudinal prevalence of diarrhoea [13]. The modelled intervention consisted of providing children from 6 to 24 months of age with 60 sprinkle sachets for a period of 4 months [13]. The sachets contain micronutrients like zinc and iron that are very important for children in this age group especially as they are fighting bacteria caused diarrhoea. Sharieff et al. calculated DALYs due to premature mortality and cost per death averted, as well as the cost per DALY reduced [13]. Their results were very positive. They determined that a short-term intervention with micronutrient sprinkles was cost-effective [13].

The literature search highlighted the lack of evidence when it comes to evaluating the economic consequences of nutrition interventions in the short and long term. The few economic evaluations in the literature have encouraged the authors to pursue an economic evaluation of a community based backyard poultry intervention. Governments and non-governmental organizations (NGOs) overlook nutrition specific interventions because their immediate consequences are not obvious to the payer. More studies of this type are needed to increase the evidence of the true impact of nutrition interventions on individuals and societies. We believe that pursuing an unconventional economic evaluation of a community based backyard poultry intervention will contribute to the literature of economic evaluations performed in nutrition specific interventions. The findings from these are summarized in **Table III**.

Burden of disease

In 2013 505,339.84 DALYs were due to PEM in Ghana. The income lost due to PEM in 2014 was \$7,006,701,819.59. The results from the burden of disease calculations are summarized in **Table IV**. The income lost due to PEM in Ghana is calculated by multiplying the number of DALYs due to PEM in 2013 by 3 times GDP per capita in 2013. Next the 2013 value was inflated to the year 2014 using United States Bureau of Labor Statistics on CPI for Ghana.

Cost of the intervention

The total cost of the intervention (including the production and overhead costs) from the payer's point of view, only considering financial costs, is \$355,173.34 in 2014 international dollars. The cost per egg produced was \$0.41. The cost per child in the intervention was \$224.65.

Reduction in infant mortality rates

The incremental effectiveness is 13 deaths averted attributable only to the intervention. The incremental cost of intervention compared to NO intervention (\$0) was \$355,173.34. The incremental cost-effectiveness ratio (ICER) is \$27,573.25. The net effect of the intervention and the incremental cost, effectiveness, and cost-effectiveness of the intervention can be seen in **Table V**.

Reduction in stunting rates

The incremental effectiveness is 138 stunting cases averted attributable solely to the intervention. The ICER is \$2,573.72 per stunted child prevented. The net effect of the intervention and the incremental cost, effectiveness, and cost-effectiveness of the intervention can be seen in **Table VI**.

DALYs averted

Within the CUA the number of averted DALYs due to premature death caused by stunting is 30.73 years per death prevented. The total number of DALYs averted in the intervention group is 1,484.28 (vs. 1,087.96 in control group). The incremental utility is 396.32 DALYs averted. The incremental cost-utility ratio (ICUR) is \$896.18 when discounted DALYs averted are used and \$117.76 – when DALYs averted are not discounted (**Table VII**). The intervention is very cost-effective even when DALYs are discounted because the ICUR is less than $1 \times$ Ghana GDP per capita in the year 2014.

Increase in Ghana future GDP

The incremental non-discounted benefit of the intervention is \$12,549,170. The incremental cost-benefit ratio of the intervention is 0.03. The results of the cost-benefit analysis, including sensitivity analysis are summarized in **Table VIII**.

Discussion

Burden of disease

The burden of disease was calculated first in order to understand the impact that stunting has on low and middle income countries. The DALYs attributable to stunting were not found in the literature. Therefore, only the DALYs attributable to PEM were presented. These calculations indicate that in the year 2014 Ghana lost over \$7 bln of national income due to PEM. This result is highly underestimated because it only considers the DALYs due to deaths and attributed to PEM instead of all the DALYs attributed to stunting and also due to disability. The DALYs due to stunting would be more comprehensive because they include a wider definition of disease. However, based on the DALYs due to PEM it is possible to see the burden that stunting currently places on Ghana's economy.

Table III. Economic evaluations on nutrition specific interventions

Paper	Author	Country	Perspective of the observation	Year	Intervention	Comparator	Target population	Economic indicators	Base line indicators	Outcome
Effect of a nutritional intervention during early childhood on economic productivity in Guatemalan adults	Hoddinott John et al. [14]	Guatemala	Societal	2008	1. <i>Atole</i> : vegetable source protein & micronutrients 2. Fresco: micronutrients only	Fresco: flavoured water with micronutrients	0-2 years old	1. Wages 2. Work hours 3. Scholastic achievements	1. Stunting 2. Socioeconomic level 3. Anaemia	Exposure to <i>atole</i> from 0 to 2 years leads to a 46% increase in a future average wages in intervention children
Cost effectiveness of responsive stimulation and nutrition interventions on early child development outcomes in Pakistan	Gowani Saima et al. [12]	Pakistan	Societal	2014	1. Nutrition stimulation 2. Responsive stimulation 3. Both	<ul style="list-style-type: none"> • Responsive estimation • Both 	6-24 months old	1. Cost of the intervention 2. Cost per unit of effectiveness 3. Cost-benefit ratio	1. Budget 2. Qualitative data 3. Anaemia	Bayley Scales of Infant and Toddler Development scores with and without stimulation
Economic gains of a Home Fortification Programs	Sharieff Waseem et al. [13]	Pakistan	Societal	2006	1. Sprinkles: supplementary micronutrients	Standard of care	0-5 years old	1. Deaths averted 2. DALYs due to deaths averted 3. Cost-benefit ratio 4. Estimation of gains in earnings	1. Deaths 2. Anaemia rates	112 deaths were averted with the use of Sprinkles. Sprinkle supplementation is cost-effective from the point of view of the provider

Source: Authors' elaboration.

Table IV. Burden caused by protein and energy malnutrition in Ghana in 2014

Burden of Disease in Ghana					
Population in Ghana in 2013	DALYs attributable to PEM per 100,000 population rate in 2013	DALYs attributable to PEM in Ghana in 2013	GDP per capita in Ghana in 2013 International \$ (PPP)	Cost of PEM in 2013 International \$ (PPP)	Cost of PEM in 2014 International \$ (PPP)
26,164,432	1,931	505,339.84	4,548.00	6,894,854,334.73	7,006,701,819.59

Source: Authors' elaboration based on data from IHME, UN Department of Economics and Social Affairs, Population Division, World Bank.

Table V. Cost-effectiveness on mortality rate

Cost-effectiveness results on mortality					
Intervention	Total cost, year 2014, International \$ (PPP)	Total effectiveness (Deaths averted)	Incremental costs year 2014, International \$ (PPP)	Incremental effectiveness (Deaths averted)	Incremental cost-effectiveness ratio (Cost per death averted) year 2014, International \$ (PPP)
Standard of care	0.00	35	–	–	–
Intervention	355,173.34	48	355,173.34	13	27,537.25

Source: Authors' elaboration.

Table VI. Cost-effectiveness on stunting rates

Cost-effectiveness results on stunting					
Intervention	Total cost, year 2014, International \$ (PPP)	Total effectiveness (Stunting cases averted)	Incremental costs, year 2014, International \$ (PPP)	Incremental effectiveness (Stunting cases averted)	Incremental cost-effectiveness ratio (Cost per stunting case averted) year 2014, International \$ (PPP)
Standard of care	0.00	550	–	–	–
Intervention	355,173.34	413	355,173.34	138*	2,573.72

* The result rounded.

Source: Authors' elaboration.

Table VII. Cost-utility analysis on DALYs due to premature death

Cost-utility using DALYs					
Intervention	Total cost, year 2014, International \$ (PPP)	Total utility (DALYs averted in intervention group and control group)	Incremental costs year 2014, International \$ (PPP)	Incremental utility (DALYs averted)	Incremental cost-utility ratio (Cost per DALY averted), year 2014, International \$ (PPP)
Standard of care	0.00	1,087.96	–	–	–
Intervention (with discounted DALYs averted, 3% discount rate)	355,173.34	1,484.28	355,173.34	396.32	896.18
Intervention (with non-discounted DALYs averted, 0% discount rate)	355,173.34	4,103.97	355,173.34	3,016.01	117.76

Source: Authors' elaboration.

Table VIII. Cost-benefit analysis, 2014 international \$ (PPP)

Cost-benefit						
Discount rate for discounting future earnings	Intervention	Total cost (I\$)	Total benefit (gains in total GDP) (I\$)	Net benefit (I\$)	Incremental benefit (I\$)	Incremental cost-benefit ratio
0%	Standard of care	0.00	118,833,953	–	–	–
	Intervention (future earnings not discounted)	355,173.34	131,383,122	12,193,996	12,549,169.58	0.03
3%	Standard of care	0.00	39,832,480.92	–	–	–
	Intervention (with 0% discounting future earnings)	355,173.34	44,038,892.87	3,851,238.60	4,206,411.94	0.08
5%	Standard of care	0.00	20,004,750.00	–	–	–
	Intervention (with 5% discounting future earnings)	355,173.34	22,117,302.80	1,757,379.46	2,112,552.80	0.17
7%	Standard of care	0.00	10,359,533.36	–	–	–
	Intervention (with 7% discounting future earnings)	355,173.34	11,453,526.60	738,819.90	1,093,993.24	0.32

Source: Authors' elaboration.

Reduction of mortality

When looking solely at the impact of the intervention on mortality rates the incremental cost-effectiveness ratio of the intervention was calculated to I\$27,537.25 in 2014. The GDP per capita in Ghana in 2014 was I\$4,086.50. Comparing the ICER to the GDP per capita we conclude that the intervention is not cost-effective when approaching it from the perspective of a decrease in the number of deaths because the ICER per death averted is higher than three times GDP per capita.

Reduction of stunting

Following the previous analysis, when looking solely at the impact of the intervention on stunting rates, the ICER of the intervention was calculated at \$2,573.72 in 2014 international dollars. When comparing the ICER to the GDP per capita the intervention is very cost effective because the ICER is less than the GDP per capita in 2014 in Ghana.

It is very important to consider that although the intervention is not considered cost-effective when solely evaluating the impact on mortality, on the contrary, the intervention is considered very cost-effective when looking at the impact on stunting. This is a great indication of the need to evaluate interventions from a multidisciplinary approach. If the present intervention was only evaluated on the basis of the reduction in mortality it would quickly be disregarded as non-cost effective. However, after estimating the cost-effectiveness of the intervention on stunting it was decided to perform additional economic analysis to be able to truly understand the impact of supplementary protein in the development of infants and nations.

economic analysis to be able to truly understand the impact of supplementary protein in the development of infants and nations.

DALYs averted

Cost utility is thought to be a more appropriate approach to evaluate the impact of a community based backyard poultry intervention because an intervention of this type impacts both the mortality and the morbidity of individuals. In order to perform a cost-utility analysis, calculating Disability Adjusted Life Years (DALYs) or Quality Adjusted Life Years (QALYs) is the first step. This first step proved to be a complicated task because in the literature there were no appropriate disability weights to calculate either DALYs or QALYs due to disability caused by stunting as a result of malnutrition. The disability weights that were found largely overlooked the lifelong consequences of stunting. Consequentially, the DALYs attributed to premature mortality due to PEM were calculated for this analysis, omitting the years lived with disability calculation.

The ICUR of the intervention was calculated at I\$896.18. This result was obtained when discounted DALYs averted were applied. When non-discounted DALYs were used, the ICUR was more favorable (every unit of additional DALYs averted by intervention, over the DALYs averted with “NO intervention,” costs I\$117.76). Comparing the ICUR to the GDP per capita we conclude that the intervention is very cost-effective even when only considering the years of life lost (YLL) part of the DALY.

Increase in Ghana's future GDP

The human capital approach was chosen for the cost-benefit analysis to understand the monetary cost of stunting to individuals and societies. It was chosen because in the evaluated modelled intervention the NGO is deciding whether to implement the intervention or not. The net benefit of the intervention is \$12,193,996.24 in 2014 international dollars. The incremental cost benefit ratio of 0.03 indicates that for every 3 cents the NGO invests in the backyard poultry intervention the return on the investment will be \$1 dollar in GDP gains. It is important to mention that the savings from Ghana's health expenditure due to stunting cases prevented was not considered in this work. Only market participation was taken into account. Even when only looking at the human capital approach to evaluate the benefit of the intervention, the results are very positive. In fact they encourage investment in the community based backyard intervention. The results of the cost-benefit analysis are a much better indication of the magnitude of the benefits of preventing stunting for individuals and entire societies. The net benefit and the incremental cost-benefit ratio presented in Table VIII are calculated both without discounting future gains in benefits and also when the sensitivity analysis is performed (with 3%, 5% and 7% discount rates on the future benefits if the stunting is reduced with the proposed intervention). We can see that in the sensitivity analysis the incremental cost-benefit ratios are 0.08, 0.17, and 0.32 respectively. This means the intervention will still be very cost-beneficial.

Limitations

Limitations from extrapolating the impact of the intervention

Several limitations were encountered when the economic evaluation was performed. The main limitation is the fact that economic evaluations are not traditionally performed in nutrition specific interventions. This fact made searching the literature for similar evaluations or even for evidence much harder than it should have been. While the INCAP study was a great source of information on the impact of supplementary protein interventions in infant mortality and stunting rates, the cause of the impact of the intervention is ambiguous. It is unknown whether it was solely due to the nutrition intervention or to possibly confounding factors. Both *atole* and *fresco* were distributed in community health centers, this could be a significant confounding factor for the reduction in mortality rates because the reduction might also be due to the fact that pregnant women and lactating mothers were more familiar with their healthcare facilities and services than they were before the intervention [39]. Another important limitation was the unit of randomization. Although the intervention was randomized, the unit of randomization was the village ($n = 4$) as opposed to individual participants ($n = 1,992$). Diminishing the statistical power of the intervention [40] forces researchers to look at the

impact of the intervention at the village level instead of at the individual level. It was decided to proceed with the data extrapolation from the INCAP study due to the multiple follow up studies that have been performed on the original cohort. The data obtained from more recent follow up studies has in fact been used by prestigious economists to model the impact of stunted intellectual and physical growth on individuals and their communities [20]. It was thought that using the study which all the data comes from, would result in values consistent with those found in the literature [20]. One of the models found an increase in average salary of 46% in males who participated in the intervention. This finding, however, was not observed in females, forcing the authors to go with a different model that used data from the same study. We decided to look instead at the per capita consumption of participants of both intervention and control groups. It is also imperative to mention that the INCAP study was performed over 45 years ago, which grants it the ability to have very rich longitudinal data that has been collected for over 40 year. This has made the data collected in recent years very rich and sophisticated. However, the originally collected data has caveats and in many cases is hard to find when one seeks to replicate estimates. Another important limitation to mention is the fact that only financial costs were used for this economic evaluation of intervention. Ideally, societal costs and economic costs would also be part of the economic evaluation. A final, but very important, limitation is that, although the intervention is targeted towards infants from six to twenty four months old, no one can guarantee that the protein – eggs will eventually make it to the infants' plates. In poor resource settings families often do not have enough food to feed their children therefore any supplementary food given to any member of the family is distributed equally among all the members of the family resulting in diluting the nutritional content of the foods and diminishing the impact of the nutrition intervention on the target population. In regards to this limitation, Ghanaian experts agree that eggs might be one of the best methods to provide protein to infants in resource poor settings. Unlike other types of protein, eggs can be added to stews, soups, and porridge making sure that at least some of it will reach all the members of the family. This is not possible with other types of proteins like chicken, beef or fish because, due to cultural factors, they are first served to adult males and might not ever make it to the plates of the infants who need them most.

Limitations from micro-costing

Micro-costing was chosen as the costing method for this intervention because of the hypothetical nature of the community based backyard poultry intervention. However, micro-costing leads to collecting costs from several different sources, which introduces error and variability to the calculations. Costs were also obtained from different years. All the costs, however, were converted into 2014 values.

Limitations from difference in the protein source of the intervention

The hypothetical community based backyard poultry intervention provides children in the intervention group with animal source protein while the intervention in the original study provided children with vegetable source protein. As mentioned previously, if the hypothetical intervention were to be implemented, the results should be greater according to recent scientific findings in the area of nutrition [41]. This implies that the extrapolated results from the INCAP intervention greatly underestimate the impact of the currently evaluated intervention.

Conclusion

A broad economic evaluation was performed on the modelled community based backyard poultry intervention. The results from the different analyses clearly show mixed evidence with mostly positive results for the community based backyard poultry intervention. While the cost-effectiveness result for mortality was negative, all the other analyses are very positive. The human capital approach to cost-benefit analysis does the best job at showing that protein supplementation during the *window of opportunity* has great payoffs in the long run for both individuals and societies. When evaluating interventions that aim at reducing stunting it is important to remember that stunting is a silent crippler of individuals and societies. Several approaches should be used to evaluate interventions that could have great impact on the future of children and their countries. Extra steps need to be taken to ensure that interventions with the potential to make an impact on the future of children and entire societies are not overlooked due to initially unfavourable results. More research still needs to be done to prove the impact for individuals and societies of reducing stunting rates around the world.

Acknowledgments

This work was made possible with the support of the Nutrition Innovation team at PATH in Seattle, USA. We would like to express our heartfelt gratitude to Nikki Kalra and Stephanie Potts for the first hand Ghana expertise they so kindly shared with the authors. We would like to thank Kimberly Amundson and Megan Parker for their nutritional insight on the appropriate protein type for the greatest health impact. Lastly, we want to thank Peiman Milani, Katharine Kreis, and Stephanie Zobrist for their support and encouragement while working on this subject.

References

- Blössner M., Onis M. De., *Malnutrition: quantifying the health impact at national and local levels*, WHO, Geneva 2005 (WHO Environmental Burden of Disease Series, No 12).
- Chopra M., Galbraith S., Darnton-Hill I., *A global response to a global problem: The epidemic of overnutrition*, "Bull. World Health Organ." 2002; 80: 952–958, doi:10.2471/BLT.12.000412.
- Hoddinott J., Alderman H., Behrman J.R., Haddad L., Horton S., *The economic rationale for investing in stunting reduction*, "Matern. Child Nutr." 2013; 9 (S2): 69–82, doi:10.1111/mcn.12080.
- UNICEF, *A Report Card on Nutrition 2006*, http://www.unicef.org/progressforchildren/2006n4/index_undernutrition.html; accessed: 2.10.2016.
- United Nations, Department of Economic and Social Affairs, *Population Division (2015). World Population Prospects: The 2015 Revision*, custom data acquired via website, <https://esa.un.org/unpd/wpp/Download/Standard/Population/>; accessed: 4.10.2016.
- Ghana Statistical Service (GSS), Ghana Health Service (GHS), *Ghana. Demographic and Health Survey 2014. Key indicators*, The DHS Program ICF International, Rockville, Maryland, USA 2015.
- UNICEF, *Strategy for Improved Nutrition of Children and Women in Developing Countries. A Policy Review*, UNICEF, New York, NY, USA 1990.
- Dewey K.G., Begum K., *Why stunting matters*, "A&T Tech. Br." 2010; 2: 1–7.
- Muennig P., Bounthavong M., *Cost-effectiveness analysis in health* Third Edit., Jossey-Bass, San Francisco 2016.
- Batura N., Hill Z., Haghparast-Bidgoli H., Lingam R., Colbourn T., Kim S. et al., *Highlighting the evidence gap: how cost-effective are interventions to improve early childhood nutrition and development?* "Health Policy Plan." 2014; 30 (6): 813–821, doi:10.1093/heapol/czu055.
- Grantham-McGregor S., Cheung Y.B., Cueto S., Glewwe P., Richter L., Strupp B., *Developmental potential in the first 5 years for children in developing countries*, "Lancet" 2007; 369 (9555): 60–70.
- Gowani S., Yousafzai A.K., Armstrong R., Bhutta Z.A., *Cost effectiveness of responsive stimulation and nutrition interventions on early child development outcomes in Pakistan*, "Ann. NY Acad. Sci." 2014; 1308: 149–161, doi:10.1111/nyas.12367.
- Sharieff W., Horton S., Zlotkin S., *Economic gains of a home fortification program: evaluation of "Sprinkles: from the providers perspective"*, "Can. J. Public Health" 2006; 97 (1): 20–23.
- Hoddinott J., Maluccio J.A., Behrman J.R., Flores R., Martorell R., *Effect of a nutrition intervention during early childhood on economic productivity in Guatemalan adults*, "Lancet" 2008; 371 (9610): 411–416.
- Heifer International, *About Heifer International 2016*, <http://www.heifer.org/about-heifer/index.html>; accessed: 13.05.2016.
- Heifer International, *Heifer International Empowering small-scale farmers*, Brochure on "Pass on the gift" programme, Little Rock AR, USA 2014.
- Prendergast A.J., Humphrey J.H., *The stunting syndrome in developing countries*, "Paediatr. Int. Child Health" 2014; 34 (4): 250–265, doi:10.1179/2046905514Y.0000000158.
- Homedes N., *The disability-adjusted life year (DALY) – definition, measurement, and potential use*. Human capital development and operations policy working papers; no.

- HCD 88 Washington DC: World Bank, <http://documents.worldbank.org/curated/en/482351468764408897/The-disability-adjusted-life-year-DALY-definition-measurement-and-potential-use>; accessed: 2.10.2016.
19. World Health Organisation, *Global Health Observatory data repository. Life Tables by Country-Ghana 2015*.
 20. Hodinott J., Rosegrant M., Torero M., *Hunger and malnutrition*, in: Lomborg B. ed., *Global Problems, Smart Solutions*, Cambridge University Press, New York 2013: 332–367.
 21. Moock P.R., Leslie J., *Childhood malnutrition and schooling in the Terai region of Nepal*, “J. Dev. Econ.” 1986; 20 (1): 33–52.
 22. Jamison D., *Childhood malnutrition and school performance in China*, “J. Dev. Econ.” 1986; 20: 299–309.
 23. Clarke N., Grantham-McGregor S., Powell C., *Health and nutrition predictors of school failure in Kingston, Jamaica*, “Ecol. Food Nutr.” 1990; 26: 1–11.
 24. Agarwal D.K., Upadhyay S.K., Tripathi A.M., Agarwal K.N., *Nutritional status, physical work capacity and mental function in school children*, UNICEF and Nutrition Foundation of India, New Delhi 1987. Sci. Rep. No 6.
 25. Florencio C., *Nutrition, health and other determinants of academic achievement and school-related behavior of grade one to grade six pupils*, University of the Philippines, Quezon City, Philippines 1988.
 26. Steegmann A.T., Datar F.A., Steegmann R.M., *Physical size, school performance, and visual-motor maturity in the Philippines*, “Am. J. Hum. Biol.” 1992; 4 (2): 247–252.
 27. Glewwe P., Jacoby H.G., King E.M., *Early childhood nutrition and academic achievement: a longitudinal analysis*, “J. Public Econ.” 2001; 81 (3): 345–368.
 28. Shariff Z.M., Bond J.T., Johnson N.E., *Nutrition and educational achievement of urban primary schoolchildren in Malaysia*, “Asia. Pac. J. Clin. Nutr.” 2000; 9 (4): 264–273.
 29. Hall A., Khanh L.N., Son T.H., Dung N.Q., Lansdown R.G., Dar D.T., Hanh N.T. et al. and Partnership for Child Development, *An association between chronic undernutrition and educational test scores in Vietnamese children*, “Eur. J. Clin. Nutr.” 2001; 55 (9): 801–804.
 30. Brito G.N., Onis Md., *Growth status, behavior and neuropsychological performance: a study of Brazilian school age children*, “Arq. Neuro-Psiquiatr.” 2004; 62 (4): 949–954.
 31. Ozmert E.N., Yurdakok K., Soysal S., Kulak-Kayikci M.E., Belgin E., Ozmert E., Laleli Y., Saracbası O., *Relationship between physical, environmental and sociodemographic factors and school performance in primary schoolchildren*, “J. Trop. Pediatr.” 2005; 51 (1): 25–32.
 32. Bogin B., MacVean R.B., *The relationship of socioeconomic-status and sex to body size, skeletal maturation, and cognitive status of Guatemala City schoolchildren*, “Child Dev.” 1983; 54 (1): 115–128.
 33. Black R.E., Victora C.G., Walker S.P., Bhutta A.Z., Christian P., de Onis M., Ezzati M., Grantham-McGregor S., Katz J., Martorell R., Uauy R., *Maternal and child undernutrition and overweight in low-income and middle-income countries*, “Lancet” 2013; 382 (9890): 427–451.
 34. Martorell R., Rivera J., Kaplowitz H., Pollitt E., *Long term consequences of growth retardation during early childhood*, in: Hernandez M., Argenta J. eds., *Human growth: basic and clinical aspects*, Elsevier Science Publishers BV, Amsterdam, Netherland 1992:143–149.
 35. Duflo E., *Schooling and labor market consequences of school construction in Indonesia: evidence from an unusual policy experiment*, “Am. Econ. Rev.” 2001; 91 (4): 795–813.
 36. Victora C.G., Adair L., Fall C., Hallal P.C., Martorell R., Richter L. et al., *Maternal and child undernutrition: consequences for adult health and human capital*, “Lancet” 2008; 371 (9609): 340–357, doi:10.1016/S0140-6736(07)61692-4.
 37. Hodinott J., Behrman J.R., Maluccio J.A., Melgar P., Qiu-suming A.R., Ramirez-Zea M. et al., *Adult consequences of growth failure in early childhood*, “Am. J. Clin. Nutr.” 2013; 98 (5): 1170–1178, doi:10.3945/ajcn.113.064584.
 38. Martorell R., Habicht J.P., Rivera J., *History and design of the INCAP longitudinal study (1969–1977) and its follow-up (1988–1989)*, “J. Nutr.” 1995; 125 (4 Suppl.): 1027S–1041S.
 39. Donald R., Martorell R., Rivera J., *Infant mortality rates before, during, and after a nutrition and health intervention in rural Guatemalan villages*, “Food Nutr. Bull.” 1992; 14: 215–220.
 40. Habicht J.P., Martorell R., Rivera J.A., *Nutritional impact of supplementation in the INCAP longitudinal study: analytic strategies and inferences*, “J. Nutr.” 1995; 125 (4 Suppl.): 1042S–1050S.
 41. Iannotti L.L., Lutter C.K., Bunn D.A., Stewart C.P., *Eggs: the uncracked potential for improving maternal and young child nutrition among the world's poor*, “Nutr. Rev.” 2014; 72 (6): 355–368, doi:10.1111/nure.12107.