

Available online at [www.sciencedirect.com](http://www.sciencedirect.com)

# Metabolism

[www.metabolismjournal.com](http://www.metabolismjournal.com)

## Brief Report

# The genetic spectrum of familial hypercholesterolemia in south-eastern Poland



Mahtab Sharifi<sup>a,1</sup>, Małgorzata Walus-Miarka<sup>b,c,\*,1</sup>, Barbara Idzior-Waluś<sup>b</sup>,  
Maciej T. Malecki<sup>b</sup>, Marek Sanak<sup>d</sup>, Ros Whittall<sup>a</sup>, Ka Wah Li<sup>a</sup>, Marta Futema<sup>a</sup>,  
Steve E. Humphries<sup>a,\*\*</sup>

<sup>a</sup> Centre for Cardiovascular Genetics, Institute of Cardiovascular Sciences, University College London, London, UK

<sup>b</sup> Department of Metabolic Diseases, Jagiellonian University Medical School, Kraków, Poland

<sup>c</sup> Department of Medical Didactics, Jagiellonian University Medical School, Kraków, Poland

<sup>d</sup> 2nd Department of Internal Medicine, Institute of Molecular Biology and Clinical Genetics, Jagiellonian University Medical School, Kraków, Poland

## ARTICLE INFO

### Article history:

Received 1 April 2015

Accepted 8 October 2015

### Keywords:

Familial hypercholesterolemia

LDLR mutation

LDL-C gene score

## ABSTRACT

**Background.** Familial hypercholesterolemia (FH) is a common autosomal dominant disorder with a frequency of 1 in 200 to 500 in most European populations. Mutations in LDLR, APOB and PCSK9 genes are known to cause FH. In this study, we analyzed the genetic spectrum of the disease in the understudied Polish population.

**Materials and methods.** 161 unrelated subjects with a clinical diagnosis of FH from the south-eastern region of Poland were recruited. High resolution melt and direct sequencing of PCR products were used to screen 18 exons of LDLR, a region of exon 26 in the APOB gene and exon 7 of PCSK9. Multiplex ligation-dependent probe amplification (MLPA) was performed to detect gross deletions and insertions in LDLR. Genotypes of six LDL-C raising SNPs were used for a polygenic gene score calculation.

**Results.** We found 39 different pathogenic mutations in the LDLR gene with 10 of them being novel. 13 (8%) individuals carried the p.Arg3527Gln mutation in APOB, and overall the detection rate was 43.4%. Of the patients where no mutation could be found, 53 (84.1%) had a gene score in the top three quartiles of the healthy comparison group suggesting that they have a polygenic cause for their high cholesterol.

**Conclusions.** These results confirm the genetic heterogeneity of FH in Poland, which should be considered when designing a diagnostic strategy in the country. As in the UK, in the majority of patients where no mutation can be found, there is likely to be a polygenic cause of their high cholesterol level.

© 2015 The Authors. Published by Elsevier Inc. This is an open access article under the CC BY license (<http://creativecommons.org/licenses/by/4.0/>).

**Abbreviations:** FH, familial hypercholesterolemia; SNP, single nucleotide polymorphism; PCSK9, protein convertase subtilisin/kexin 9 gene; APOB, apolipoprotein B gene.

\* Correspondence to: M. Walus-Miarka, Department of Metabolic Diseases, Jagiellonian University Medical College, 31-501 Kraków, Kopernika 15, Poland. Tel.: +48 12 424 83 01; fax: +48 12 421 97 86.

\*\* Correspondence to: S. E. Humphries, Centre for Cardiovascular Genetics, British Heart Foundation Laboratories, Institute of Cardiovascular Science, The Rayne Building University College London, London, WC1E 6JF, UK. Tel.: +44 207 679 6962 (internal 46962); fax: +44 20 7679 6212.

E-mail addresses: [m.walus-miarka@uj.edu.pl](mailto:m.walus-miarka@uj.edu.pl) (M.ł Walus-Miarka), [steve.humphries@ucl.ac.uk](mailto:steve.humphries@ucl.ac.uk) (S.E. Humphries).

<sup>1</sup> These authors contributed equally.

<http://dx.doi.org/10.1016/j.metabol.2015.10.018>

0026-0495/© 2015 The Authors. Published by Elsevier Inc. This is an open access article under the CC BY license (<http://creativecommons.org/licenses/by/4.0/>).

## 1. Introduction

Familial hypercholesterolemia (FH) is an autosomal dominant disorder with a frequency of 1 in 200 to 500 in European populations [1]. It is characterized by a raised concentration of low-density lipoprotein cholesterol (LDL-C) and high risk of premature coronary heart disease [2].

Mutations in the *LDLR* gene, the *APOB* gene and gain-of-function mutations in the *PCSK9* gene are known to cause FH [3]. Usually an FH-causing mutation can be found in 60–80% of patients with a clinical diagnosis of definite FH and 20–30% of those with possible FH [4]. In those where no causative mutation is found, there is a strong possibility that there may be a polygenic cause for FH [5].

In Poland, FH is an under-diagnosed condition with only 20% of the cases estimated to be diagnosed to date [6]. The aim of this study is to assess the spectrum of FH-causing mutations in the Malopolska population in east-southern Poland.

## 2. Methods

### 2.1. Subjects

161 unrelated Caucasians patients with a clinical diagnosis of FH based on Simon Broome criteria [7] were recruited. Ethical approval was obtained from the Jagiellonian University Medical College Ethics Committee (KBET/34/B/2012).

### 2.2. Molecular Genetic Analysis

All samples were screened for mutations in all 18 exons of *LDLR* gene, a fragment of exon 26 of *APOB* to cover p.Arg3527Gln and exon 7 of *PCSK9* to cover p.Asp374Tyr by high resolution melt and direct sequencing of PCR products as described in Supplementary 1. Multiplex ligation-dependent probe amplification to detect gross deletions and insertions in *LDLR* and in silico prediction of pathogenicity of

identified variants were performed [8]. The LDL-C gene score was calculated using weighted sums for six LDL-C raising SNPs [5].

### 2.3. Statistical Analysis

The data were not normally distributed and log-transformed data were used for the analysis. One-way ANOVA was used to compare the lipid parameters and gene score between the mutation positive and negative groups (SPSS version 21). *p* Value <0.05 was used to denote significance.

## 3. Results

### 3.1. Patient Characteristics

Baseline characteristics of the cohort are shown in Table 1. Mean  $\pm$  SD maximum total cholesterol (TC) was  $9.9 \pm 2.6$  mmol/L and mean  $\pm$  SD current LDL-C was  $4.8 \pm 1.8$  mmol/L. Detailed lipid parameters of the individual patients are shown in Supplementary 2.

### 3.2. Mutation Spectrum

Overall we detected a mutation in 70 out of 161 (43.4%) patients. Mutation positive group had a significantly higher TC level ( $10.5 \pm 3.2$  vs.  $9.5 \pm 2.1$ , *p* = 0.039) than mutation negative group (Table 1). In 38 patients with a clinical diagnosis of definite FH, we did not find a mutation. The most frequent mutation was in *APOB* (p.Arg3527Gln), found in 13 (8%) patients. No patient carried the *PCSK9* p.Asp374Tyr mutation. Mutations in the *LDLR* gene were identified in 57 patients and accounted for the majority (81.4%) of all the mutations found in this cohort. We identified six different major rearrangements in 12 patients, which accounted for 17.1% of all FH causes in our cohort. Among the intronic variants found, all were previously reported as splice-site-

**Table 1 – Baseline characteristics of the 161 participants.**

Variable	Total	Mutation positive	Mutation negative	p Value
	N (%)	N (%)	N (%)	
Male	55 (34.2)	26 (37.1)	29 (31.9)	0.48
Tendon xanthomata	92 (57.1)	43 (60.6)	49 (54.4)	0.53
Family history of premature CAD <sup>1</sup>	79 (49.1)	38 (53.5)	41 (45.6)	0.38
Personal history of premature CAD	21 (13.0)	10 (14.1)	11 (12.2)	0.77
On lipid-lowering medication <sup>2</sup>	110 (68.3)	40 (57.1)	70 (76.7)	0.007
	Mean ( $\pm$ SD)	Mean ( $\pm$ SD)	Mean ( $\pm$ SD)	
Age (years)	42 (17.6)	38 (17.9)	46 (16.6)	0.004
Maximum TC (mmol/L)	9.9 (2.6)	10.5 (3.2)	9.5 (2.1)	0.039
LDL-C (mmol/L) <sup>3</sup>	4.8 (1.8)	5.1 (2.0)	4.5 (1.5)	0.046
HDL-C (mmol/L)	1.5 (0.3)	1.4 (0.3)	1.5 (0.3)	0.223
TG (mmol/L)	1.5 (0.8)	1.2 (0.7)	1.7 (0.9)	0.001

<sup>1</sup> CAD = coronary artery disease.

<sup>2</sup> At the time of study recruitment.

<sup>3</sup> Current level.

**Table 2 – LDLR and APOB variants identified in the study.**

DNA level	Protein level	N	Exon	Prediction			
				PolyPhen	SIFT	Mutation Taster	splice site effect
<b>LDLR gene</b>							
<b>Major rearrangement</b>							
c.-187-?_67 + ?dup	p.(?)	1	promoter-ex1 dup	n/a	n/a	n/a	n/a
c.-187-?_67 + ?del	p.(?)	1	>30 kb upstream of the promoter-ex1 del	n/a	n/a	n/a	n/a
c.-187-?_190 + ?del	p.(?)	1	promoter-ex2 del	n/a	n/a	n/a	n/a
c.941-?_1060 + ?del	p.Gly314_Glu353del	1	ex7del	n/a	n/a	n/a	No
c.314-?_1186 + ?dup	p.Gly396Ala;Pro106_Val395dup	2	ex4-ex8 dup	n/a	n/a	n/a	No
c.695-?_1586 + ?del	p.Val233Serfs*18	6	ex5-10 del	n/a	n/a	n/a	No
<b>Probably pathogenic</b>							
c.100T > G	p.Cys34Gly	3	2	Probably damaging	Not tolerated	Disease causing	No
c.185C > T	p.Thr62Met	1	2	Probably damaging	Tolerated	Disease causing	No
c.380T > A	p.Val127Asp	1	4 <sup>1</sup>	Possibly damaging	Not tolerated	Disease causing	No
c.501C > A	p.Cys167*	1	4	n/a	n/a	n/a	No
c.530C > T	p.Ser177Leu	1	4	Benign	Not tolerated	Disease causing	No
c.654_656delTGG	p.Gly219del	1	4	n/a	n/a	Disease causing	No
c.666C > A	p.Cys222*	1	4	n/a	n/a	n/a	No
c.681C > G	p.Asp227Glu	1	4	Probably damaging	Not tolerated	Disease causing	No
c.764G > A	p.Cys255Tyr	1	5 <sup>1</sup>	Probably damaging	Not tolerated	Disease causing	No
c.798T > A	p.Asp266Glu	1	5	Probably damaging	Not tolerated	Disease causing	No
c.986G > T	p.Cys329Phe	4	7 <sup>1</sup>	Probably damaging	Not tolerated	Disease causing	No
c.1048C > T	p.Arg350*	1	7	n/a	n/a	n/a	No
c.1085delA	p.Asp362Alafs*8	1	8	n/a	n/a	Disease causing	No
c.1246C > T	p.Arg416Trp	2	9	Probably damaging	Not tolerated	Disease causing	No
c.1449G > T	p.Trp483Cys	1	10 <sup>1</sup>	Possibly damaging	Not tolerated	Disease causing	No
c.1567G > A	p.Val523Met	1	10	benign	Not tolerated	Disease causing	No
c.1720C > T	p.Arg574Cys	1	12	Probably damaging	Not tolerated	Disease causing	No
c.1737C > G	p.Asp579Gly	3	12 <sup>1</sup>	probably damaging	Not tolerated	Disease causing	No
c.1775G > A	p.Gly592Glu	4	12	probably damaging	Not tolerated	Disease causing	No
c.1834G > T	p.Ala612Ser	2	12 <sup>1</sup>	Possibly damaging	Not tolerated	Disease causing	No
c.1862C > G	p.Thr621Arg	1	13 <sup>1</sup>	Probably damaging	Not tolerated	Disease causing	No
c.1975_1987 + 16del	p.(?)	1	13 <sup>1</sup>	n/a	n/a	n/a	Yes
c.2026G > C	p.Gly676Arg	1	14	Probably damaging	Not tolerated	Disease causing	No
c.2032C > T	p.Gln678*	2	14	n/a	n/a	n/a	No
c.2054C > T	p.Pro685Leu	1	14	Probably damaging	Not tolerated	Disease causing	No
c.2096C > T	p.Pro699Leu	2	14	Probably damaging	Not tolerated	Disease causing	No
c.2096delC	p.Pro699Argfs*10	1	14 <sup>1</sup>	n/a	n/a	Disease causing	No
c.2546C > A	p.Ser849*	1	17 <sup>1</sup>	n/a	n/a	n/a	No
<b>Intronic pathogenic</b>							
c.313 + 1G > A	p.Leu64_Pro105delinsSer	1	intron 3	n/a	n/a	n/a	Yes
c.1705 + 1G > A		2	intron 11	n/a	n/a	n/a	Yes
c.2140 + 5G > A		2	intron 14	n/a	n/a	n/a	Yes
c.2389 + 5G > A		1	Intron 16	n/a	n/a	n/a	Yes
<b>Non-pathogenic</b>							
c.1171G > A	p.Ala391Thr	3	8	Benign	Tolerated	Polymorphism	No
c.1545C > T	p.Asn515Asn	1	10	n/a	Tolerated	Polymorphism	No
c.1920C > T	p.Asn640Asn	1	13	n/a	n/a	Polymorphism	No
c.1959C > T	p.Val653Val	1	13 <sup>1</sup>	n/a	n/a	n/a	No
c.2025C > T	p.Gly675Gly	1	14 <sup>1</sup>	n/a	n/a	Disease causing	No
c.2177C > T	p.Thr726Ile	2	15	Benign	Tolerated	Polymorphism	No
c.2231G > A	p.Arg744Gln	1	15	Benign	Tolerated	Polymorphism	No
c.2390-16G > A	Intronic	3	intron 17 <sup>1</sup>	n/a	n/a	n/a	No
<b>APOB gene</b>							
c.10580G > A	p.Arg3527Gln	13	APOB ex26	Probably damaging	Not tolerated	n/a	n/a

<sup>1</sup> Novel; n/a = not applicable.

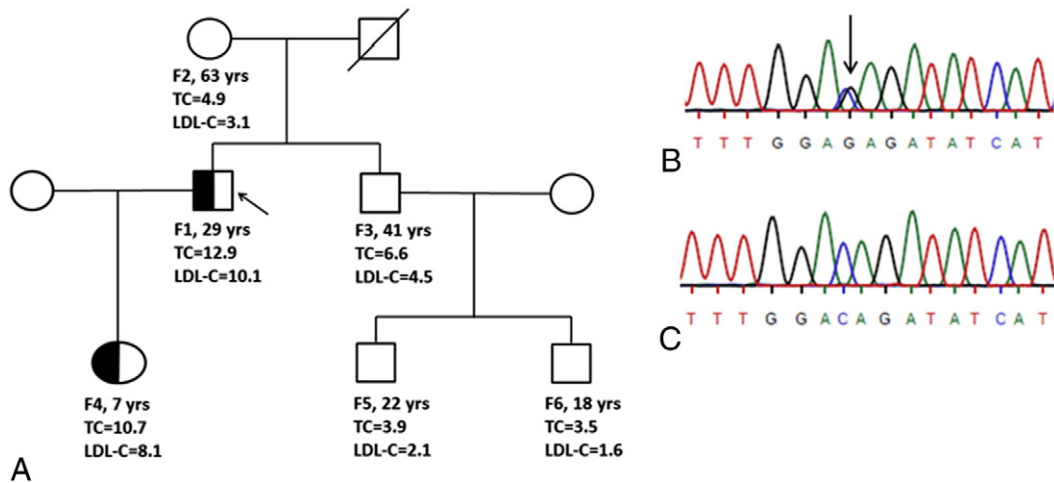

**Fig. 1 – Family co-segregation of the novel c.1862C > G (p.Thr621Arg) LDLR mutation. (A) A family pedigree of the index patient (F1) with the novel mutation including age (years), TC level (mmol/L) and LDL-C level (mmol/L). Five members of the family (F2, F3, F4, F5 and F6) were screened and sequenced for the mutation. Only F4 was found to carry the novel variant as the index, which co-segregated with FH phenotype. (B) LDLR exon 13 sequencing for the index patient (appropriate base arrowed), (C) Wild type exon 13 sequence.**

modifying mutations and therefore considered to be pathogenic ([www.ucl.ac.uk/ldlr](http://www.ucl.ac.uk/ldlr)) except c.2390-16G > A which is not near to the splice site; thus, based on prediction tools it was designated as non-pathogenic.

We also identified 13 LDLR variants that were considered non-pathogenic. Seven of these variants were present in patients already identified with a pathogenic mutation (Table 2).

### 3.3. Novel Mutations

We found 10 novel mutations in the LDLR gene (Table 2). The mutation c.1975\_1987 + 16del, is predicted to delete the last four amino acids of exon 13 and the consensus splice site, and is predicted to result in a frame shift. The mutation c.2096delC will also result in a frame shift in exon 14 (p.Pro699Argfs\*10) and would be pathogenic. The mutations p.Cys255Tyr and p.Cys329Phe, would cause loss of cysteine in the ligand binding domain of the LDL-receptor and cause aberrant protein folding. The mutation p.Ser849\* causes a premature stop codon at position 849 in the cytoplasmic tail of LDL-receptor, known to be important for the localisation of the receptor in coated pits on the cell surface.

We predict that the novel mutation (p.Thr621Arg) would cause aberrant recycling of the LDL-receptor protein to the cell surface and is thus pathogenic. Analysis of the proband's family members showed that this mutation segregated with the disease. From five family members, the daughter was found to have a raised TC level (10.7 mmol/L) and LDL-C level (8.1 mmol/L) and inherited the p.Thr621Arg mutation. The index father, who had raised serum cholesterol levels, died of myocardial infarction at the age of 46 (Fig. 1).

The other four novel mutations, p.Ala612Ser, p.Asp579Gly, p.Trp483Cys, and p.Val127Asp were also predicted to be pathogenic; however family members of these patients were not available for segregation analysis.

### 3.4. LDL-C Gene Score

Genotypes for all six SNPs were obtained for 101 patients. Compared to the control group mean  $\pm$  SD score ( $0.63 \pm 0.22$ ), the mutation negative patients had the highest LDL-C score ( $0.68 \pm 0.21$ ), followed by the mutation positive patients ( $0.67 \pm 0.21$ ). Following the previously reported trend [5], as expected for a sample of this size, none of these SNP score differences were statistically significant (Fig. 2). Using the control cohort SNP score quartiles, out of the 63 genotyped mutation negative FH patients, 53 (84.1%) had a SNP score above the bottom quartile ( $>0.51$ ) and therefore the cause of high LDL-C in these patients is likely to be polygenic.

## 4. Discussion

In this cross-sectional genetic study, we had an overall FH mutation detection rate of 43.4%. This finding is in agreement with previous studies of European populations [9], and similar to that reported in the UK [4,10]. Approximately 30% of patients with a raised LDL-C level (42.9% of mutation positive and 23.3% of mutation negative) were not on any lipid-lowering medication at the time of recruitment due to their first attendance to lipid clinic for initiation of lipid-lowering drug, statin intolerance or pregnancy. The significantly higher cholesterol levels in monogenic group are likely to be attributed to presence of genetic mutation.

The spectrum of LDLR mutations in Europe varies between countries, from Greece with only six mutations responsible for causing FH in 60% of the cases, to Netherlands with the most heterogeneous spectrum [11,12] and to the UK with over 200 different mutations [13]. We found 39 different FH mutations in a cohort of 161 patients, which suggests a broad spectrum of mutations and high heterogeneity of FH in Poland. The most common APOB mutation in European

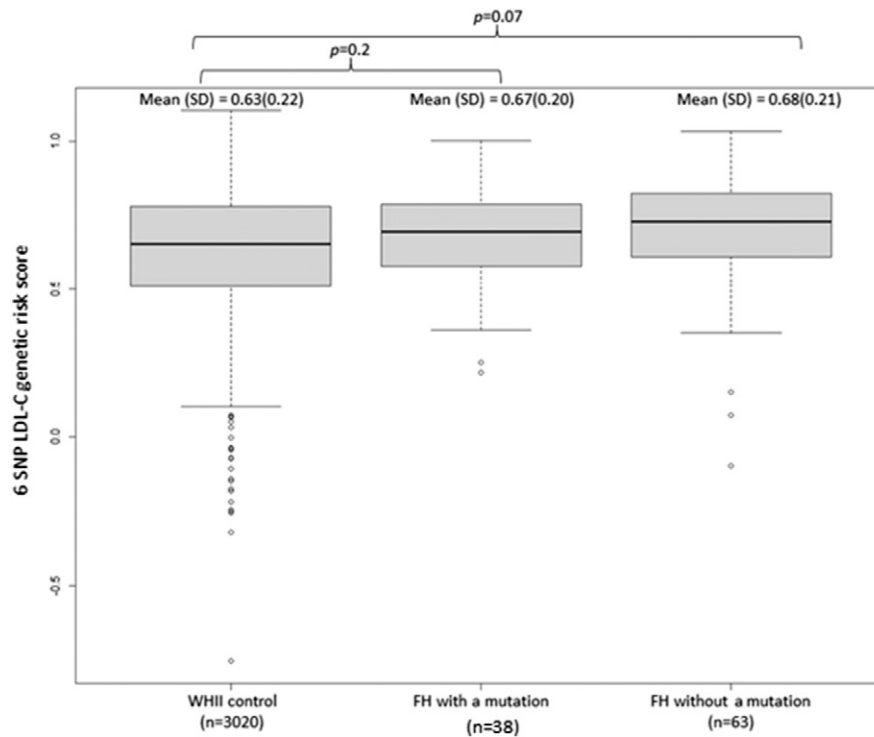

**Fig. 2 – LDL-C genetic risk score analysis based on a 6-SNP score (Futema et al. 2015). Genotypes for 6 LDL-C-associated SNPs were available for 91 out of 101 studied FH patients. For additional nine patients with a one missing APOE genotype we assumed that they had the E3E3 isoform (the most common). One more patient had a missing rs6511720 genotype and we assumed that the patient did not have the risk allele for this SNP. The highest mean score (standard deviation (SD)) was observed in individuals with the clinical diagnosis of FH where no mutation detected (0.68 ( $\pm$ 0.21)). Individuals from the control cohort (WHII) had the lowest mean score (SD) (0.63 ( $\pm$ 0.22)), whereas those with a confirmed FH mutation had intermediate score (0.67 ( $\pm$ 0.21)). The differences between the FH patients and the control did not reach a statistical significance.**

populations p.Arg3527Gln usually accounts for 5–7% of FH patients [14]. We found this mutation in 8% of the patients in south-eastern part of Poland, which is similar to that reported in the northern part of Poland [15,16]. The frequency of large insertion/deletions was also higher than in a recently reported UK sample (16.7% vs. 10%) [8]. These findings highlight the importance of including the APOB gene and large LDLR gene rearrangements tests in the mutation screening of Polish people.

We found ten novel pathogenic mutations in the LDLR gene based on multiple prediction algorithms and demonstrated co-segregation of the novel mutation p.Thr621Arg with the FH phenotype. We also described the novel mutation of p.Cys329Phe in a previous report [17]. In our study, the mean weighted LDL-C raising SNPs gene score for patients without a mutation was higher than the control group as was shown in previous studies in Europe [5,18]. In patients where no mutation was found, 84.1% had a gene score in the top three quartiles of the score based on the healthy comparison group, suggesting that they have a polygenic cause for their high cholesterol levels. By contrast, in the remaining 10 mutation-negative patients who were found to have a low SNP score (in the bottom quartile), it is likely that there is a single mutation in a region of the LDLR, APOB and PCSK9 genes not examined here, or there might be a mutation in a yet to be

discovered gene. Further family studies and use of more comprehensive next generation sequencing methods in these patients may help to distinguish these possibilities.

There are limitations to our study. We had a small number of samples and we only examined the regions of APOB and PCSK9 where the most common FH-causing mutations occur. Also due to lack of consent, we could not perform co-segregation in all patients with novel variants.

The scale of FH under-diagnosis in Poland has been recently highlighted [6,19] and, as in other European countries, there is an urgent need for a national management plan and an efficient mutation testing strategy in Poland.

### Author Contributions

MSh, MWM, BIW, MTM, MSa, RW, KWL, MF and SHE were involved in analysis, data interpretation and drafting paper. MWM and BIW collected data.

### Acknowledgements

SEH holds a Chair funded by the British Heart Foundation. SEH and RW are supported by the BHF. MF is supported by

the National Institute for Health Research UCL. MWM is funded by Ministerstwo Nauki i Szkolnictwa Wyższego (grant K/PMI/000004).

### Conflict of Interest

The authors have no conflict of interest.

### Appendix A. Supplementary data

Supplementary data to this article can be found online at <http://dx.doi.org/10.1016/j.metabol.2015.10.018>.

### REFERENCES

- [1] Austin MA, Hutter CM, Zimmern RL, Humphries SE. Genetic causes of monogenic heterozygous familial hypercholesterolemia: a HuGE prevalence review. *Am J Epidemiol* 2004; 160(5):407–20.
- [2] Marks D, Thorogood M, Farrer JM, Humphries SE. Census of clinics providing specialist lipid services in the United Kingdom. *J Public Health (Oxf)* 2004;26(4):353–4.
- [3] Soutar AK, Naoumova RP. Mechanisms of disease: genetic causes of familial hypercholesterolemia. *Nat Clin Pract Cardiovasc Med* 2007;4(4):214–25.
- [4] Taylor A, Wang D, Patel K, Whittall R, Wood G, Farrer M, et al. Mutation detection rate and spectrum in familial hypercholesterolaemia patients in the UK pilot cascade project. *Clin Genet* 2010;77(6):572–80.
- [5] Talmud PJ, Shah S, Whittall R, Futema M, Howard P, Cooper JA, et al. Use of low-density lipoprotein cholesterol gene score to distinguish patients with polygenic and monogenic familial hypercholesterolaemia: a case–control study. *Lancet* 2013;381(9874):1293–301.
- [6] Idzior-Walus B, Sanak M, Starzyk J, Czarnecka D, Walus-Miarka M. Autosomal dominant hypercholesterolemia — underrecognised diagnostic and clinical problem. *Kardiol Pol* 2009;67(9):1015–22.
- [7] DeMott K, Nherera L, Shaw EJ, Minhas R, Humphries SE, Kathoria M, et al. Clinical Guidelines and Evidence Review for Familial hypercholesterolaemia: the identification and management of adults and children with familial hypercholesterolaemia. London: National Collaborating Centre for Primary Care and Royal College of General Practitioners; 2008.
- [8] Futema M, Whittall RA, Kiley A, Steel LK, Cooper JA, Badmus E, et al. Analysis of the frequency and spectrum of mutations recognised to cause familial hypercholesterolaemia in routine clinical practice in a UK specialist hospital lipid clinic. *Atherosclerosis* 2013;229(1):161–8.
- [9] Fouchier SW, Kastelein JJ, Defesche JC. Update of the molecular basis of familial hypercholesterolemia in The Netherlands. *Hum Mutat* 2005;26(6):550–6.
- [10] Futema M, Plagnol V, Whittall RA, Neil HA, Humphries SE. Use of targeted exome sequencing as a diagnostic tool for Familial Hypercholesterolaemia. *J Med Genet* 2012;49(10):644–9.
- [11] Glynou K, Laios E, Drogari E, Tsaoussis V. Development of a universal chemiluminometric genotyping method for high-throughput detection of 7 LDLR gene mutations in Greek population. *Clin Biochem* 2008;41(4–5):335–42.
- [12] Dedoussis GV, Schmidt H, Genschel J. LDL-receptor mutations in Europe. *Hum Mutat* 2004;24(6):443–59.
- [13] Leigh SE, Foster AH, Whittall RA, Hubbart CS, Humphries SE. Update and analysis of the University College London low density lipoprotein receptor familial hypercholesterolemia database. *Ann Hum Genet* 2008;72(Pt 4):485–98.
- [14] Liyanage KE, Burnett JR, Hooper AJ, van Bockxmeer FM. Familial hypercholesterolemia: epidemiology, Neolithic origins and modern geographic distribution. *Crit Rev Clin Lab Sci* 2011;48(1):1–18.
- [15] Chmara M, Wasag B, Zuk M, Kubalska J, Wegrzyn A, Bednarska-Makaruk M, et al. Molecular characterization of Polish patients with familial hypercholesterolemia: novel and recurrent LDLR mutations. *J Appl Genet* 2010;51(1):95–106.
- [16] Bednarska-Makaruk M, Bisko M, Pulawska MF, Hoffman-Zacharska D, Rodo M, Roszczyńko M, et al. Familial defective apolipoprotein B-100 in a group of hypercholesterolaemic patients in Poland. Identification of a new mutation Thr3492Ile in the apolipoprotein B gene. *Eur J Hum Genet* 2001;9(11):836–42.
- [17] Walus-Miarka M, Sanak M, Idzior-Walus B, Miarka P, Witek P, Malecki MT, et al. A novel mutation (Cys308Phe) of the LDL receptor gene in families from the South-Eastern part of Poland. *Mol Biol Rep* 2012;39(5):5181–6.
- [18] Futema M, Shah S, Cooper JA, Li K, Whittall RA, Sharifi M, et al. Refinement of variant selection for the LDL cholesterol genetic risk score in the diagnosis of the polygenic form of clinical familial hypercholesterolemia and replication in samples from 6 countries. *Clin Chem* 2015;61(1):231–8.
- [19] Rynkiewicz A, Cybulska B, Banach M, Filipiak K, Guzik T, Idzior-Walus B, et al. Management of familial heterozygous hypercholesterolemia: position paper of the Polish Lipid Expert Forum. *J Clin Lipidol* 2013;7(3):217–21.