

CENTRE FOR APPLIED SOCIAL SCIENCES *

University of Zimbabwe
P O Box MP 167
Mount Pleasant
HARARE
Zimbabwe

(CASS Occasional Paper - NRM Series; CPN 104/2000)

CAMPFIRE:
Policy Changes & Legislative Amendments –
Programme Impact in the New Millennium

By
M. Moyo
February 2000

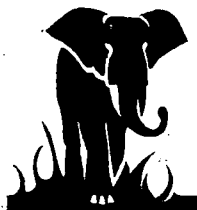

“This publication has been possible through the support of the US Agency for International Development (USAID) under the Natural Resources Management Project (NRMP) Phase II – Zimbabwe. The opinions expressed herein are those of the author and do not necessarily reflect the views of USAID or CASS.”

TABLE OF CONTENTS

| | | |
|------------|---|-----------|
| 1. | Introduction..... | 1 |
| 2. | Terms of Reference for the Study | 1 |
| 3. | Methodology Used in the Study..... | 1 |
| 4. | Background on CAMPFIRE | 2 |
| 5. | CAMPFIRE in the Context of Resource Tenure in Zimbabwe | 3 |
| | 5.1 State property regimes..... | 4 |
| | 5.2 Private property regimes..... | 4 |
| | 5.3 Common property regimes | 5 |
| | 5.4 Open access regimes..... | 5 |
| 6. | Local Governance and Institutional Context..... | 6 |
| 7. | Decentralisation, Devolution and Privatisation | 10 |
| 8. | CAMPFIRE and Gender | 11 |
| 9. | Legislation Related to the Implementation of CAMPFIRE | 12 |
| | 9.1 Parks and Wildlife Act, Chapter 20:14..... | 12 |
| | 9.2 Forest act, Chapter 150..... | 12 |
| | 9.3 Communal Land Forest Produce Act..... | 13 |
| | 9.4 Natural Resources Act..... | 14 |
| | 9.5 Rural District Councils Act, 1988..... | 14 |
| 10. | The Draft Environment and Natural Resources Management Bill..... | 15 |
| | 10.1 Background to the environmental law reform process..... | 15 |
| | 10.2-Rationale for the new Bill..... | 17 |
| | 10.3 Principles of Zimbabwe's environmental law reform..... | 17 |
| 11. | Provisions of the Draft Environment and Natural Resources Management Bill that have a Bearing on CAMPFIRE..... | 18 |
| 12. | Issues Raised by Stakeholders during the Research | 22 |
| 13. | Recommendations..... | 23 |
| | 13.1 Legislative provisions..... | 23 |
| | 13.2 Administrative changes necessitated by provisions of the proposed legislation | 24 |
| 14. | Current Status and the Legislative Process of Draft Bill..... | 26 |
| 15. | Resources Required to Implement Recommendations..... | 27 |
| 16. | Conclusion | 27 |
| | References..... | 28 |

1. Introduction

This study was commissioned by the Centre for Applied Social Sciences (CASS) at the University of Zimbabwe. CASS has supported CAMPFIRE through research and analysis of policy issues that affect the programme. Recently, a number of policy changes and legislative amendments have been proposed and these are likely to have an impact on the CAMPFIRE programme.

A draft Environment and Natural Resources Management Bill has been developed and if enacted will replace the Natural Resources Act. The bill provides an overall legislative framework for environment and natural resources management in the country. It also seeks to rationalise the hitherto fragmented environmental legislation and to bring key elements of such legislation under the co-ordination of the ministry responsible for environmental affairs. This proposed legislative change is likely to have an impact on the structures and institutions that are responsible for natural resources management. Lower level institutions of Rural District Councils (RDCs) are also likely to be affected. It is thus imperative to understand the nature of such changes and how they will impact on programmes whose thrust is the development of these lower level institutions as a basis for effective community based natural resources management (CBNRM). It is intended to use results of this research to assist the CAMPFIRE Association and other CAMPFIRE partners to fully appreciate the nature and impact of these proposed changes so that they may respond appropriately.

This paper first looks at the resource tenure and local governance contexts within which the CAMPFIRE programme is being implemented and associated institutional arrangements. This background is useful in the understanding of possible impacts of the proposed legislative changes on the programme and its thrust towards community based natural resource management. The paper will also look at related legislation before discussing the proposed Environment and Natural Resources Management Bill and how it will impact on the CAMPFIRE programme. Based on the research findings and conclusions, recommendations will be made on the way forward.

2. Terms of Reference for the Study

The following are the Terms of Reference for this study as provided by CASS:

- Review relevant Acts and the Bill;
- Review related studies on tenure, community and local governance, community based natural resources management and other relevant studies;
- Consult, if possible, those responsible for compiling the Bill so as to get a full understanding of the Bill's rationale;
- Consult with NGOs, Rural District Councils and Government Departments actively participating in the CAMPFIRE Programme to get their views on the Bill;
- Highlight both negative and positive impacts of the Bill on CAMPFIRE;
- Make suggestions on how existing structures can be modified to take into account the Bill and indicate resources and actions required for managing the change.

3. Methodology Used in the Study

This study was undertaken using a combination of literature review and interviews. The literature review concentrated on issues of resource tenure, CBNRM, local governance, reports on CAMPFIRE activities over the years of implementation, environmental legislation and other

related issues. A number of literature sources were used, including research libraries, government reports and NGO libraries, especially those of members of the CAMPFIRE Service Providers.

Interviews were conducted with a wide range of stakeholders involved with the CAMPFIRE programme. These included representatives of the CAMPFIRE association, representatives of sample CAMPFIRE RDCs (Nyaminyami, Gokwe South, Bulilimangwe, Chiredzi and Hwange), representatives of government departments and NGOs that are involved with the CAMPFIRE programme and some community representatives. The list of all institutions and people interviewed during the course of this study is attached to this report as Annex 1.

In addition to the literature review and interviews, the study also benefited from deliberations of the NRB organised *National Conference on Environmental Conservation* that took place in Harare from 31 May to 2 June 1999. The draft Environment and Natural Resources Management Bill was discussed at length during the conference and these discussions provided useful insights into what government intends to achieve with the proposed legislative changes.

4. Background on CAMPFIRE

In considering possible impacts of the proposed legislative changes on the CAMPFIRE programme, it is imperative to have clarity on the background to the programme and what the programme is intended to achieve. The impact of the proposed legislative changes must be considered within the context of the objectives of the programme. Thus the proposed changes will either have a positive or a negative impact on the programme depending on whether or not such changes will add value to the objectives of the programme.

The Department of National Parks and Wildlife Management conceived the CAMPFIRE programme in the early 1980s, as a policy response to potential decimation of wildlife species within and outside the Parks Estate. Conceptually, the programme seeks to place proprietorship of natural resources in Zimbabwe's communal areas with local communities. The basic assumption of the programme is that, through direct benefits derived from their management of these resources, communities would have a vested interest in the conservation of these resources. Two major legislative developments marked the origin of this concept. First, the Parks and Wildlife Act of 1975 designated owners of private land or the lessees of State land (collectively termed 'alienated land') as the 'Appropriate Authority' to manage their wildlife resources. This effectively meant that they became the proprietors of these resources. There was an apparent discrimination in this provision in that it did not include communal areas of the country where a majority of the population resides. This anomaly was rectified in a 1982 amendment that extended the interpretation of the term 'Appropriate Authority' to include Rural District Councils who are both the administrative and development planning authorities in the communal areas.

Martin (1986) gave the objectives of CAMPFIRE as, among others:

- To initiate a programme for the long term development, management and sustainable utilisation of natural resources in the communal areas;
- To achieve management of resources by placing the custody and responsibility with the resident communities;
- To allow communities to benefit directly from the exploitation of natural resources within the communal areas; and
- To establish the administrative and institutional structures necessary to make the programme work.

In pursuance of these objectives, a lot has been achieved on the ground. By 1999, 36 RDCs had been granted 'Appropriate Authority' status, allowing them control over management and

utilisation of resources within their respective areas of jurisdiction. To assist these RDCs in their responsibilities over sustainable management of their natural resources, implementation of the programme took a multi-disciplinary approach. The establishment of the CAMPFIRE Collaborative Group (CCG) provided essential support to the RDCs. The CCG comprises seven different institutions, now known as CAMPFIRE Service Providers (CSP), with each fulfilling a specific role within the programme. The group includes:

1. **Department of National Parks and Wildlife Management**, which provides policy guidance and ecological monitoring/advisory services;
2. **Ministry of Local Government and National Housing**, which has responsibility over RDCs and their committees;
3. **WWF Zimbabwe**, providing ecological and economic expertise;
4. **Zimbabwe Trust (ZIMTRUST)**, providing institutional development support and funding for RDCs and their committees;
5. **Centre for Applied Social Sciences (CASS)**, contributing policy research and socio-economic expertise and monitoring support;
6. **Africa Resources Trust (ART)**, providing information and links to international networks on major issues affecting international policy and regulations; and
7. **CAMPFIRE Association**, whose main role is to co-ordinate all RDCs with 'Appropriate authority' status and represent their interests in a policy advocacy role.

5. **CAMPFIRE in the Context of Resource Tenure in Zimbabwe**

A number of factors have an influence on CBNRM. One of these critical factors is the resource tenure question. It is thus important to understand Zimbabwe's tenure system in relation to resource management. Zimbabwe's tenure system is well documented in the literature. There are basically four categories of land tenure in Zimbabwe. These are:

1. **Communal tenure** based on usufruct tenure system. The Commission of Inquiry into Appropriate Agricultural Land Tenure Systems (1994) identified two components of the communal tenure system. The first component encompasses arable and residential land that is held under freehold tenure with family members having a right to sub-divide such land or to bequeath or inherit. The second component comprises communal tenure for the grazing, forests and other resources.
2. **Resettlement** based on leasehold tenure.
3. **State Land** comprising state farming land, gazetted forestland and National Parks;
4. **Commercial farming land** (large and small scale) which is on freehold tenure system.

There is considerable debate in the literature with respect to the precise definition of "communal" land tenure (Murombedzi, 1990a). It is often assumed in the literature that communal land tenure, and indeed other resource tenure systems, are static and have remained so over the years. This is not necessarily the case as many internal dynamics have come into play and are slowly reshaping resource tenure in the communal areas. In their study on a tenurial approach to local management of trees and woodland resources in Zimbabwe, Fortmann and Nhira (1992) conclude that:

"Tenurial approaches must be recognized as evolving rather than static forms of social organization, even when their legal status remains static. For example, indigenous woodlands in many areas are undergoing piecemeal conversion from common property

to private property as they are annexed by individuals who fence them for their exclusive personal use... The de facto rather than de jure status of commercial farm land has also fluctuated between greater and lesser private control."

Economic changes, population density, urbanisation and investments in land have seen a process of differentiation (between the rich and poor peasantry) in the communal areas of the country with the consequential redefinition of relations with the natural resources. Murombedzi (1990a) further points to the apparent contradiction that exists between the "normative" definition of "communal" land tenure and the *de facto* land holding practices in the communal areas. In the light of this, Scoones and Matose (1993) argue that "resource management and tenure policy options need to be differentiated to take account of the huge variety of dynamic and evolving tenure settings". More work still needs to be done in order to unravel the complexities of the communal land tenure system.

The significance of the tenure debate with respect to resource management is realised through whether or not there is security of tenure with respect to each tenure system. Security of tenure is generally associated with four sets of rights. The rights are:

1. Use rights;
2. Transfer rights;
3. Exclusion rights; and
4. Enforcement rights, referring to legal and administrative provisions meant to guarantee these rights.

The thrust of CAMPFIRE is towards residents within the communal tenure system. Natural resources in this tenure system are commonly referred to as common property. In order to put the question of common property resources in proper perspective, it will be useful to have an understanding of property rights and the respective natural resource regimes governing such rights.

Natural resource regimes constitute explicit structures of rights and duties that characterise the relationship of individuals to one another with respect to a particular resource. Such regimes are associated with the establishment of institutional arrangements which, according to Bromley (1992), "define (or locate) one individual *vis-à-vis* others both within the group (if there is one) and with individuals outside the group" with respect to a particular resource. Bromley continues,

"We can define property relations between two or more individuals (or groups) by stating that one party has an interest that is protected by a right only when all others have a duty to protect that right."

Bromley proceeds to define four possible resource regimes as follows:

5.1 State property regimes

Under this regime, ownership and control over use of the resource rests with the State. Individuals and groups may be able to make use of the resource but only at the forbearance of the State. Such resources may include state farming land, gazetted national forests and national parks, for example. Shifts from state property to other types, or *vice versa*, are possible. The State may also give usufruct rights to individuals or groups of individuals.

5.2 Private property regimes

This is the most familiar type of property regime. While most private property is individual property, this regime also includes corporate property. Private property entails "the legally and

socially sanctioned ability to exclude others" in the use of a resource. Commercial farms, both large and small scale would fall under this property regime.

5.3 Common property regimes

The third regime is the common property regime (*res communes*). This regime is the most common in rural communities of Zimbabwe. Simply, this regime may be viewed as private property for a particular group of individuals with decision authority to exclude others. An effective common property regime has an in-built incentive structure that encourages compliance with existing group conventions and institutions. Thus this regime is based on traditions and customs of the people, and is enforced through group consensus. However, it is important to note that when the institutions and the inherent ability of the group to exclude others are weakened, a situation typical of the fourth regime below will result. Thus the institutional context prevailing in Zimbabwe's rural communities has a bearing on whether or not the shift from this property regime to an open access situation described below will take place.

It must also be noted that the Commission of Inquiry into Appropriate Agricultural Land Tenure Systems, in its 1994 report, recommends the continuation of communal tenure but strengthened through a series of measures aimed at improving security of tenure. The Commission concluded that, "by strengthening village level institutions, the management of grazing and other communally owned natural resources should improve considerably". Institutional arrangements for natural resources management, including the implementation of CAMPFIRE, are discussed under section 6 below.

5.4 Open access regimes

In this regime there is no property (*res nullius*). The regime is characterised by there being no authority. It's an 'open-for-all' situation. Because of this, the resource is exploited on a first-come-first-served basis. The result is serious resource depletion. Bromley also argues that governments who have appropriated forests, for example, from local-level management bodies (primarily villages) under common property resource regimes, and failed to manage them in an effective manner "have created *de jure* state property but *de facto* open access."

Wade (1987) also talks about a continuum of property rights. Common property lies in the middle of the continuum in which open access is at one end and private property at the other.

From the above definitions, and in relation to communal tenure, it is important to differentiate between common property and open access regimes. These two have very often been confused in the debate regarding the causes of natural resource degradation in communal areas of the country. To assume that the common property regime inherently leads to resource degradation is to confuse it with the open access situation. It may be argued that historical developments that have resulted in the confusing authority system in the country's communal areas are to blame for the apparent shift from common property to open access resource use in some communal areas. Bromley and Cernea (1988, quoted in Murombedzi, 1990b) note the role of the dissolution of local level resource management institutions in resource degradation:

"Resource degradation in developing countries, while incorrectly attributed to 'common property resources' actually originates in the dissolution of local institutional arrangements whose very purpose was to give rise to resource use patterns that were sustainable..."

In the case of Zimbabwe, for instance, it has also been argued that changes introduced by the Communal Lands Act of 1982, and in which the rights of traditional leaders to allocate land were withdrawn in favour of VIDCOs, was a contributory factor to resource degradation. This change is considered to have upset centuries old traditional land and resource control institutions (Murphree and Cumming, 1991; Scoones and Matose, 1993).

Murombedzi (1994) recommends the institution of a common property regime over wildlife and notes the negative impact of the erosion of effective common property by the emergence of new state-elaborated forms of property systems that recognised basically two forms of property, private property and state property. This has contributed to the current situation in the communal areas.

In light of the foregoing, it is therefore important to appreciate the fact that the solution to the common property resource problem in Zimbabwe is not necessarily privatisation of the resource. This will merely institute a different tenure regime. The solution might be found in addressing the institutional and policy weaknesses that undermine the common property regime.

6. Local Governance and Institutional Context

The importance of local government in natural resources management cannot be over-emphasised. The establishment of democratic local government institutions at Independence in 1980, through setting up of District Councils and subsequently Rural District Councils (RDCs) in 1984, was in part a realisation by the authorities of the need to effectively involve communities in governance and development planning. In terms of the Regional, Town and Country Planning Act of 1975 as well as the Rural District Councils Act of 1984, Rural District Councils are the planning authorities in their respective areas of jurisdiction and they also have a natural resources management responsibility. The Communal Lands Act of 1982 also made the RDCs land authorities. It is by virtue of their responsibility over natural resources management that the Parks and Wildlife Act, as amended in 1982, provides for the granting of "Appropriate Authority" status to RDCs to enable them and their communities to gain proprietorship over and directly benefit from their wildlife resources.

The 1984 Prime Minister's Directive attempted to decentralise development planning through the establishment of village and ward development committees (VIDCOs and WADCOs). These institutions were regarded as appropriate local level management structures. However, these new institutional structures tended to sideline the traditional authority system in the communal areas. Conflict was thus inevitable as has been witnessed over the years. Sithole and Bradley (1995) in their analysis of institutional conflicts over the management of communal resources note that, "during the colonial period, centralization policies and land re-organization disrupted the boundaries of indigenous institutions and established representatives of state institutions at the local level." They note that while there was no documentation of contradictions between the two during the colonial period, these contradictions have been noted and documented since the advent of Independence.

Thomas (1992) concludes that VIDCOs and WADCOs have been ineffective for a number of reasons. First, he argues that their legitimacy was questioned by their constituency, the rural communities who have had long and established beliefs in the traditional authority system. Second, these institutions had no financial resources with which to function. It has also been noted that these institutions have largely been used by government for the implementation of centrally conceived plans and programmes rather than as institutions to enhance local participation in the planning process (Murombedzi, 1994). In his analysis of institutional structures for natural resources management in Kanyati, Nhira (1990) also notes some weaknesses of these structures when he observed that the "VIDCOs were not instrumental in the reorganization of settlement but were subordinated to the wishes of technical personnel" (p.131).

In addition, it has been observed that the VIDCO and WADCO boundaries were not necessarily aligned with the co-existing communal boundaries, thereby creating uncertainties over institutional jurisdiction, with obvious implications for effective local level resource management.

The above problems notwithstanding, it must still be recognised that the RDC/WADCO/VIDCO structure is the one that has, over the years, been the formally recognised local governance structure in the communal areas of the country. It is instructive at this point to examine current

institutional arrangements for CAMPFIRE implementation in the districts visited during this study. Institutions established in the implementation of CAMPFIRE in RDCs with Appropriate Authority are summarised below:

MODEL A

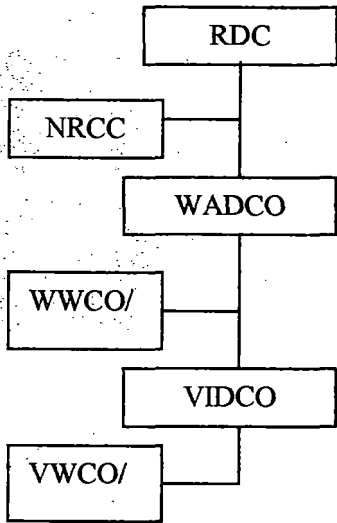

MODEL B

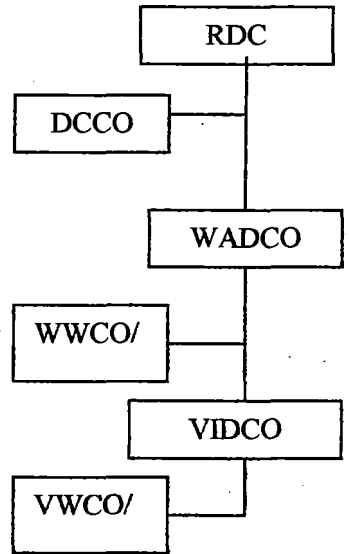

MODEL C

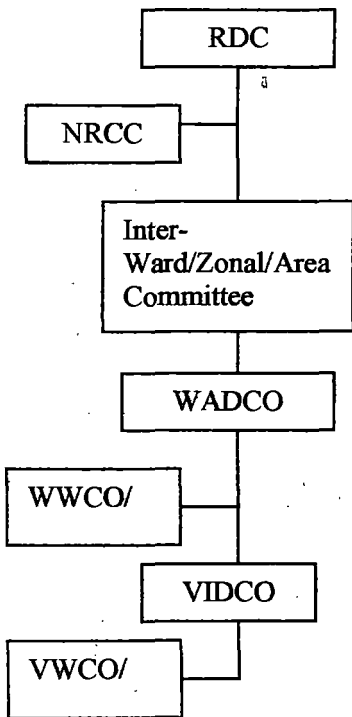

MODEL D

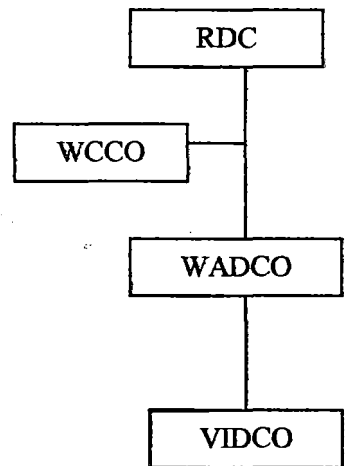

Figure 1: The four generic structures identified

In general, the structures are very similar at sub-district level with Village Wildlife/Campfire Committees (VWCO/VCCO) and Ward Wildlife/Campfire Committees (WWCO/WCCO) as sub-committees of Village Development Committees (VIDCO) and Ward Development Committees (WADCO) respectively. However, only one district (Model D) does not have these sub-committees and thus the VIDCO and WADCO assumes all the functions under the CAMPFIRE programme.

Models A & B

Above the ward level the structures differ more significantly. Some RDCs have a District Campfire Committee (DCCO) as a sub-committee of the RDC, in addition to the NRCC that is mandatory for every RDC in terms of the Rural District Councils Act. The NRCC also handles issues of natural resource management and ideally the CAMPFIRE issues should fall under it. The difference between the two is that, whilst the NRCC comprises of selected councillors from any ward, the DCCO is made up of councillors and co-opted members from CAMPFIRE producer communities only. Although this looks like an obvious duplication of structures it has been justified as follows:

- ❖ That within the NRCC, councillors with producer communities' interests are normally overpowered by votes as they may well be outnumbered by those from other areas. This compromises the empowering effect of the programme and the general principle that the affected people should gain from managing their resources.
- ❖ Councillors from non-producer communities do not fully understand problems and issues in producer communities to competently recommend to full council about them.
- ❖ CAMPFIRE duties are very **demanding** and therefore there is need to meet more often than the NRCC normally does. As a **result**, councillors from non-producer communities would not be expected to cope with extra work that does not particularly affect their wards.

Model C

This model includes an additional structure between the WADCO and NRCC. This structure comprises representatives from several CAMPFIRE wards who look into the CAMPFIRE issues before making recommendations to the NRCC. The following problems were raised with respect to this structure:

- ❖ The structure is very bureaucratic and results in delays in the implementation of activities by producer communities. In general, additional structures usually create disharmony with existing structures and normally increase bureaucracy.
- ❖ In addition, all the constraints noted under Model A are inherent in this structure as well.
- ❖ Since the structure is longer the decision-making role of the communities is further compromised.

There has, however, been a new development following the promulgation of the Traditional Leaders Act (Chapter 29:17) that is significant with respect to the implementation of the CAMPFIRE programme. Some of the changes incorporated in this new Act follow recommendations made in the 1992 Report of the Commission of Inquiry into Appropriate Agricultural Land Tenure Systems. One of the major recommendations of this Commission with respect to communal tenure was the strengthening of the traditional authority system and the establishment of village and ward assemblies as the more appropriate local governance institutions. These new institutions have now been provided for in the new Traditional Leaders Act. This development necessitates revisiting current CAMPFIRE structures discussed above.

In terms of this new law, the lowest unit of local governance will be the Village Assembly. The assembly will be composed of all the inhabitants of the village concerned and who are above the

age of eighteen years. The village head will be the chairman of the assembly. The functions of the village assembly as provided for include:

- To consider all matters, including cultural matters, affecting the interests and well-being of all the inhabitants of the village;
- To ensure good government of the village in compliance with the Act as well as with the Communal Lands Act (Cap.20:04) and the Rural District Councils Act (Cap. 29:13);
- To consider and resolve all issues relating to land, water and other natural resources within the area and to make appropriate recommendations in accordance with any approved layout or development plan of the village or ward;
- To elect and supervise the village development committee; and
- To review and approve any village development plan before its submission to the ward development committee for incorporation into the ward development plan.

Above the village assembly will be the ward assembly that will be composed of all headmen, village heads and the councillor of the respective ward. The chairmanship of the ward assembly will rotate annually among the headmen in the assembly. The functions of the ward assembly will generally be supervisory to the activities of all the village assemblies in the ward and to co-ordinate development planning in the ward for incorporation into district development plans.

In terms of this new law, VIDCOs and WADCOs become committees of village and ward assemblies respectively. VIDCO members will be elected from members of the village assembly. The establishment of WADCOs is provided for in terms of Section 59 of the Rural District Councils Act that specifies that these will comprise chairmen and secretaries of VIDCOs and will be presided over by the ward councillor.

The significance of these changes lies in the fact that VIDCOs and WADCOs have been made subservient to assemblies that bring together all the village stakeholders (in the case of the village assembly) and their representatives (in the case of the ward assembly). The role of the traditional leadership appears to have been enhanced since it has been integrated into the new administrative structures.

With respect to CAMPFIRE programme delivery within this institutional set up, the main focus will be on the lowest unit of governance, i.e. the village assembly. This institution should form the focus of CAMPFIRE efforts at assisting the development of defined user groups that can regulate resource utilisation and exclude non-users from the benefit of common resources. In the past, the jurisdictional conflict between the formal local government structures of VIDCOs and WADCOs and the parallel traditional structures made it difficult to clearly define the decision authority on matters relating to natural resources management. In the light of this confusion, programmes working with communities often came up with parallel structures that attempted to bring together the traditional leadership and these local administration authorities.

Institutional arrangements will be critical to the successful implementation of CAMPFIRE. The institutions that I refer to in this context are both the village assembly and the ward assembly. It is important to point out that the term "institutional arrangements" does not only refer to the establishment of these two institutions as constituted bodies of persons, but also to the prescribed constitution that will guide their activities. With respect to natural resources management, these institutions will need to be empowered so that they appreciate their role in this regard and are able to regulate resource utilisation in their areas of jurisdiction.

One of the main weaknesses of institutions established in the context of CAMPFIRE as observed by Murombedzi (1994) is the fact that the institution building process did not attempt to develop institutions in the normal sense of integrative mechanisms for regulation of access to resources. He argues that attempts, within the CAMPFIRE context, to provide material and technical

assistance to institutions established under the programme without reconstructing community rights over the resource are pointless. In order to change the pattern of resource utilisation there is need to first change the structure of property rights to resources. A larger programme on capacity building for these institutions should, therefore, be the major focus of CAMPFIRE and its co-operating partners.

7. Decentralisation, Devolution and Privatisation

The government adopted a decentralisation strategy as early as 1984 through the Prime Minister's Directive. This directive saw the establishment of lower tier structures of WADCOs and VIDCOs. While these structures were intended to contribute towards the bottom-up planning approach, in reality they lacked both the authority to engage in planning as well as the financial resources for the purpose. Thus, in theory, there was decentralised planning; while, in reality, planning remained centralised. In 1997 government came up with a decentralisation policy that was to guide all government departments. The policy was specific in terms of what responsibilities were to be removed from the centre and given to local authorities. With respect to natural resources management, this responsibility was to be given to local authorities.

It has been argued in the past that although local authorities, in particular Rural District Councils, were given responsibility over natural resources management, they have been reluctant to devolve this responsibility to lower level institutions and the communities. Decentralised responsibility must, of necessity, also go with decentralised decision making. This includes management decisions as well as decisions over resource use and sharing of benefits.

There is a school of thought that suggests that devolving responsibility to communities in the communal areas under communal tenure will further continue resource degradation. This is based on the assumption that common-property resource management arrangements will inevitably lead to an open access situation. The solution proffered is that of creating private property regimes. Smith (1981), in analysis of Hardin's *Tragedy of the Commons*, concludes "The only way to avoid the tragedy of the commons in natural resources and wildlife is to end the common property system by creating a system of private property rights" (p. 467).

In the case of Zimbabwe's communal areas, a question may be posed as to what privatisation would mean in the context of the social fabric of communal land dwellers, the majority of whom have strong extended family and social and cultural ties, as communities, to their natural resources. Might privatisation of resources not dislocate this social and cultural unity of the communities?

In his study on mechanisms to strengthen community involvement in decision making for desertification control, Mpande (1996) refutes the privatisation scenario with respect to Zimbabwe's communal area situation. He identifies a number of reasons why communities in the communal areas attempt to maintain common control of resources and prevent their privatisation. Some of these reasons are:

- The relative poverty of villages means that the transaction costs of a well-defined and enforced private property regime will be too great to bear, making joint use rights a necessity;
- A village economy is critically dependent on local agriculture and natural resources. Because of the random distribution of natural resources, the assignment of exclusive use rights to a piece of land in a given area can lead to uneven distribution of resources, and can be further skewed by differentiation, leading to destabilisation of the system;
- Poverty and randomly distributed natural resources makes survival more subject to a variety of unpredictable natural events. As such, environmental uncertainty contributes to the

development of common property institutions designed to include the whole group in resource use, as an insurance against failure.

In its 1992 report on Appropriate Agricultural Land Tenure Systems, the Commission of Inquiry concluded:

"The Commission recommends that communal tenure has to be maintained and strengthened through a series of measures that would improve security of tenure and improve the legal and administrative mechanisms necessary for long-term evolution of the system to meet changing needs..."

This conclusion was arrived at after the Commission received considerable evidence from many stakeholders. Bromley and Cernea, (1989) also advocate for a return to common property regimes based on the utility of such regimes in sustainable resource management. This is conditional on there being appropriate local level institutions adequately empowered to manage the common property resource. Murphree, (1991) also lends weight to the need to empower local institutions as agents of sustainable common property resource management. He concluded:

"The evidence is that communities can become effective institutions for sustainable resource management, but only if they are granted genuine proprietorship, i.e. the right to use resources, determine the mode of usage, benefit fully from their use, determine the distribution of such benefits and determine rules of access. Any policy which excludes these components will frustrate the goal of making communities effective institutions for resource management."

Part of this paper's analysis of the proposed Environment and Natural Resources Management Bill will be based on the need to strengthen the common property resource regime through devolution of responsibility and decision making to local level institutions and developing capacity for such institutions to take on the responsibility effectively.

8. CAMPFIRE and Gender

The gender dimension is an important consideration in the successful implementation of CAMPFIRE. Studies on the role of women in Zimbabwe's communal areas show that although women provide most of the production labour (Cliffe 1986), the male head of household makes the basic decisions. This is despite the fact that most males in the communal areas are only occasionally resident in these areas. In addition, there are a high percentage of female-headed households as the men migrate to work in either urban areas or at mines and farms. It is because of the traditional dominance of men in their society that women are often excluded from decisions concerning land use and natural resources management.

Nabane (1994) notes that decision making in natural resources management programmes is male dominated as a result of the patriarchal nature of most societies and that the wildlife arena is no exception. In her analysis of a community based initiative in wildlife utilisation in the Zambezi Valley under the CAMPFIRE programme, Nabane concludes that CAMPFIRE has gender differentiated outcomes:

"Benefit distribution which is biased towards male participants, raises the need to focus explicitly on women's interests and needs both at household, community and policy making levels. This would reduce the chances of the programme having negative impacts that may arise as a result of overlooking the importance of the gender variable. Differentiation of resource users and programme beneficiaries should further be reflected in natural resource management related policies in general" (p.24).

Scoones and Matose (1993) also note deficiencies in customary law with respect to women and property rights. As a result, women tend to have very limited land rights, for instance. Such rights

are invested in men. In terms of section 8 of the Communal Land Act, widows have no right to inherit and therefore lack protection after their husbands have died. The impact of the limited land rights of women on their incentives to be productive and conserve the natural resources is difficult to assess.

In spite of the above constraints, it is noted that CAMPFIRE has encouraged women to assert their rights to participate in decision making relating to natural resources management and benefit sharing. In Kanyurira ward in the north-east of the country, for instance, gender issues were raised for the first time when household dividends were distributed, with a number of women wanting to be registered in their own right since they worked in the fields that were destroyed by wildlife (Campfire Association).

The development of natural resource management legislation, therefore, needs to take into consideration gender imbalances with a view to promoting equity in access, use and benefit sharing.

9. Legislation Related to the Implementation of CAMPFIRE

CAMPFIRE has to do with sustainable management and utilisation of natural resources through community based approaches. It has to do with community empowerment and legislation is an important link in the empowerment process. There is an array of legal instruments that have a bearing on the CAMPFIRE programme. These instruments have either a positive or a negative impact on the programme. This section will look at some of these legal instruments in relation to the CAMPFIRE programme as a prelude to the review of the proposed Environment and Natural Resources Management Bill. Five pieces of legislation will be briefly reviewed in as far as they have a bearing on the CAMPFIRE programme. These include the:

Parks and Wildlife Act, Chapter 20:14;

Forest Act, Chapter 19:03;

Communal Lands Forest Produce Act.

Natural Resources Act, Chapter 20:13; and

Rural District Councils Act, Chapter 20:8.

9.1 Parks and Wildlife Act, Chapter 20:14

This Act was promulgated in 1975 and amended in 1982 to make provisions that lay the basis for CAMPFIRE. In terms of this Act, "ownership" of all wildlife is vested in the State and the Department of National Parks and Wildlife Management is the institution that manages wildlife both within and without the Parks Estate. In terms of this Act, i.e. (Section 108), the Minister in relation to communal lands may, where appropriate, declare a Rural District Council to be an "Appropriate Authority". This has been the legal basis for CAMPFIRE schemes. The "Appropriate authority" is essentially a person who has the legal authority to manage wildlife and to benefit from it. This necessarily begs the question whether it is appropriate to vest title in the Rural District Council. The answer may be in the negative because the council reports to the Minister and not to communities. This marginalises the majority of local people who do not participate meaningfully and directly in the decision-making process. However, it is important to acknowledge the role of the Rural District Council in regulation and monitoring natural resources management in its respective area of jurisdiction.

9.2 Forest act, Chapter 150

The Act provides for state intervention to protect forests through the declaration and protection of gazetted forests that include plantation forests, indigenous forests, private protected forests and

reserved trees. With respect to forest management in Zimbabwe, there are two systems of forest and woodland management, which are not necessarily mutually exclusive:

- (i) **Management systems initiated and implemented by the state.** The major piece of legislation through which this strategy is implemented is the Forest Act. The Forestry Commission is the institution created in terms of the Act and is responsible for the setting of terms and conditions of timber exploitation and ensuring compliance.
- (ii) **Management and systems initiated and implemented by local communities.** This strategy is not provided for by legislation governing forest produce in communal areas as the Rural District Councils administer these areas.

9.3 Communal Land Forest Produce Act

This Act has a bearing on woodland use in communal areas of the country and is particularly relevant where CAMPFIRE expands its scope beyond wildlife use. It remains separate from the Forest Act, and reflects the dual nature of colonial legislation, with different laws applying in different, originally racially determined, land tenure categories. In terms of this Act, all woodland within communal areas falls under the authority of the Rural District Council, which has discretion to give right to utilise communal woodlands. The Act restricts exploitation of forest produce to own use (Section 4). This has been interpreted by the implementing agencies to mean domestic use. This interpretation is based on the colonial history that gave the perception that communal residents' right to forest produce was purely subsistence. Utilisation of major forestry produce is only allowed in terms of a permit or licence (Section 7).

No forestry produce exploited in the exercise of these rights shall be sold to anyone who is not an inhabitant of such area. This impacts negatively on the exchange of woodland resources that has traditionally taken place across boundaries in the communal areas.

The Minister has the power to issue to any person (Section 7) a licence to exploit forestry produce and the Minister is not obliged to consult with the inhabitants of the area. The Minister's powers are executed through the Rural District Councils. They are empowered to enter into agreement with commercial logging companies in order to exploit timber within districts, and with the revenue going to these RDCs. Forestry Commission, as the legal guardian of National Forest resources, is responsible for setting terms and conditions for timber exploitation and ensuring compliance [S.I. 9 of 1989].

Timber concessions in communal lands are beset with numerous problems, which impact directly upon the efficient management of woodland resources. Some of these problems are as follows:

- The tendency by Councils to ignore the very existence of local communities when negotiating timber concessions; and
- Communities do not benefit from these concessions, but invariably bear the costs e.g. extraction damage, for which they receive no form of compensation.

A case in point is that of Tsholotsho where there was vigorous opposition by villagers to logging in Dhlamini Ward. People felt that they were not benefiting in any way, as the area is underdeveloped. They claimed that Council did not spend any money on upgrading their services, and reclaiming depleted areas.

The Act also has a schedule of 60 reserved trees, the exploitation of which is prohibited except with a special licence or a special permit. This list includes many of the more important fruit trees (e.g. *Parinari curatellifolia*, *Uapaca kirkiana*) that communities could exploit commercially under the CAMPFIRE concept.

9.4 Natural Resources Act

This is a broad piece of legislation providing general supervisory powers to the Natural Resources Board that in turn operates through committees. It does not specifically address issues pertaining to the CAMPFIRE programme.

The overall purpose of the Act is to make provision for the conservation and improvement of natural resources of Zimbabwe. The Act creates a Natural Resources Board whose functions include:

- General supervision over natural resources;
- Public education and awareness through the dissemination of information by such means as it may deem expedient; and to
- Recommend to government such legislative measures as it may deem to be necessary for the improvement, use and conservation of natural resources.

The general powers are given specific content in terms of Parts V and VI. Part V provides for the declaration of conservation of areas. An intensive conservation area may be declared where holders in an area want to initiate conservation construction works. The Act provides for the voluntary establishment of Intensive Conservation Areas (ICAs) on alienated land (i.e. owner occupied or private land) and how these committees may be constituted. The major function of these committees is to ensure the preservation, protection and improvement of natural resources in their respective areas and to make recommendations to the Board (Section 38a).

[Part VI] of the Act makes provision for the conservation and improvement of natural resources in communal lands. In terms of section 46(1) the Board may, with the approval of the minister responsible for the Communal Lands Act, direct that the whole or part of that land be reserved against human occupation, cultivation, pasturing of animals, cutting down of any vegetation.

It must be noted, however, that this Act will be repealed upon promulgation of the proposed Environment and Natural Resources Management Act.

9.5 Rural District Councils Act, 1988

This Act provides for the establishment of Rural District Councils. It gives power to the Councils over many aspects related to the management of natural resources in the communal areas of the country. These powers range from land administration, development control and service delivery to the conservation of natural resources. The Councils exercise these powers through by-laws and making orders in terms of the by-law. The Act also makes provision for the establishment of Natural Resources Conservation Committees and sub-committees of Council with responsibility over management of natural resources.

The significance of the Council's Natural Resources Conservation Committee is that, as the Council committee tasked with the responsibility over the management of natural resources, all CAMPFIRE issues would logically fall under this committee. However, in most cases and especially in the CAMPFIRE districts, councillors sitting on these committees do not necessarily represent producer communities and, as such, their interest in CAMPFIRE issues is minimal, if at all, and they lack full understanding of problems and issues affecting producer communities.

It must be noted that the draft Environmental Management Bill also seeks to transfer the Natural Resources Committees from the Rural District Council to the new Bill.

By and large, all the legislation discussed above has a bearing on natural resources management in communal areas. In considering discussions on the proposed Environment and Natural Resources Management Bill, and its impact on the CAMPFIRE programme, it becomes

imperative to also consider how provisions in these other related Acts have been taken into account in the new Bill. For instance, how far do these have any bearing on the CAMPFIRE programme? This question will be discussed later in this report.

10. The Draft Environment and Natural Resources Management Bill

This section looks at the background to the draft Environment and Natural Resources Management Bill including the process leading up to the current draft, various stages that the draft has gone through and its current status. An appreciation of this process is important for the CAMPFIRE Association and its partners for purposes of identifying intervention points in an attempt to influence legislative amendments that are supportive of the CAMPFIRE initiative. The section will also look at the rationale for the draft Bill, those provisions that have a bearing on CAMPFIRE and the relationship between the Bill and other environment and natural resources management related legislation.

10.1 Background to the environmental law reform process

Environmental legislation in Zimbabwe has, over the years, been topical in environmental circles. This question has to be looked at on the basis of two factors. Firstly, it has to be looked at historically. Most of the laws currently in existence were formulated during the Federation and UDI eras. Their focus therefore tends to be limited and there is a failure in most of them to address aspects of contemporary concern.

Secondly, it must be stated that the environmental legal regime is scattered over at least 18 ministries. This situation has been characterised by jurisdictional conflicts not conducive to effective environment and natural resources management. In addition, where different officers in different ministries enforce pieces of legislation, there is always a problem with lack of uniformity in the manner in which administrative discretion is utilised in the administration of the legal regime. Thus, it is possible and commonplace to find, for instance, that in one industry aspects of environmental protection would receive top billing whilst in another sector other considerations would be more favoured.

Table A (below), adopted from a report by Webster Chinamora and Don Ruhukwa entitled "Towards an Environmental Management Act: Review and Revision of Zimbabwe's Environmental Legislation," gives a clear picture of this fragmentation and the inherent dangers alluded to above. Government has long recognised this problem of fragmentation in environmental legislation. In its national report to the 1992 Earth Summit, Zimbabwe admitted, "The legislation detailed above provides for most institutional mandates. The implementation of these mandates has created numerous problems. Though the mandates themselves are clear, they tend to lead to conflict..." (Government of Zimbabwe, 1992, p. 35).

Many stakeholders have in the past called for government to take steps to rationalise all environmental legislation. In response to this call, the Zimbabwe Government, through the Ministry of Mines, Environment and Tourism initiated the Environmental Law Reform Process. This process effectively started in 1996 when government initiated nation-wide consultations with all stakeholders. These consultations culminated in the draft Environmental Management Bill that was produced in March 1998. This initial draft was widely circulated for further comments by stakeholders. By December 1998 these consultations had been completed and the ministry then proceeded to produce a bill for consideration by Cabinet and the Attorney General's Office.

In developing the draft Bill, the ministry considered a number of options with respect to the form and nature that the new Bill would take. The first draft that was produced in 1998 was in the form of a "Framework" legislation for environmental management in the country. What this "framework" legislation would do is to essentially set the broad parameters for environmental management with minimum standards that all the other sectoral legislation would draw from. This

option would leave the other pieces of legislation under current jurisdictions, but draw on standards provided for in the draft Environmental Management Bill. Based on this option, the Ministry of Mines, Environment and Tourism proceeded to draw up principles that were subsequently approved by the Cabinet Committee on Legislation and submitted to the Attorney General's Office for legal drafting.

Table A:

| Legislation | Responsible Authority |
|---|---|
| Natural Resources Act | Ministry of Mines, Environment and Tourism |
| Mines and Minerals Act | Ministry of Mines, Environment and Tourism |
| Atmospheric Pollution Prevention Act | Ministry of Health and Child Welfare |
| Water Act | Ministry of Lands and Agriculture |
| Forest Act | Ministry of Mines, Environment and Tourism |
| Fertilizer, Farm Feeds and Remedies Act | Ministry of Lands and Agriculture |
| Communal Land Forest Produce Act | Ministry of Mines, Environment and Tourism |
| Hazardous Substances and Articles Act | Ministry of Health and Child Welfare |
| Trapping of Animals (Control) Act | Ministry of Mines, Environment and Tourism |
| Parks and Wildlife Act | Ministry of Mines, Environment and Tourism |
| Regional Town and Country Planning Act | Ministry of Local Government and National Housing |
| Rural District Councils Act | Ministry of Local Government and National Housing |
| Income Tax Act | Ministry of Finance |
| Land Acquisition Act | Ministry of Lands and Agriculture |
| Agricultural Land Settlement Act | Ministry of Lands and Agriculture |
| Factories and Works Act | Ministry of Public Service, Labour and Social Welfare |
| Agricultural Development Authority Act | Ministry of Lands and Agriculture |
| Prevention of Cruelty to Animals Act | Ministry of Mines, Environment and Tourism |

Another option that the ministry had considered was the "omnibus" option. The "omnibus" option entails rationalising all environmental legislation with a view to bringing the major ones under one jurisdiction, that of the Ministry of Mines, Environment and Tourism.

However, after further consideration and consultation, the ministry decided to develop a draft Bill that was a combination of the two options. The draft Bill submitted to the Attorney General's office for legal drafting would thus be both framework legislation, and one that would also bring under it key legislation from other jurisdictions. To that end, a second draft Bill titled "**Environment and Natural Resources Management Bill**" was drafted in early 1999. This second draft includes issues relating to pollution control and hazardous articles and substances that currently fall under the jurisdictions of the Ministry of Rural Resources and Water Development and the Ministry of Health and Child Welfare. It also incorporates the control of noxious weeds that hitherto fell under the Ministry of Lands and Agriculture.

This second draft was widely endorsed by the National Conference on Environment and Natural Resources Conservation that was organised by the Natural Resources Board from 31 May – 2 June 1999. It is this second draft that will be the subject of analysis in this report with respect to its potential impact on the CAMPFIRE programme. At the time of writing this report, this second draft Bill had not gone for legal drafting. It must also be noted that the form of the final draft is likely to be different from the current draft; and, in which case, specific sections as referred to in this study may also change.

10.2 Rationale for the new Bill

The Bill is intended to:

- Rectify many deficiencies in current legislation and bring Zimbabwe up to date in environmental management;
- Integrate the country's scattered environmental legislation under one umbrella, and address all issues that are a threat to the environment;
- Give Ministry of Mines, Environment and Tourism a special role of superintending the new law in line with the country's environmental aspirations;
- Form a framework legislation with which housekeeping changes can be made to existing legislation, and standards can be set for environmental management while maintaining existing institutions and allowing for modification of their mandates;
- Allow for a co-ordinated and/or co-operative decision-making process amongst the various government ministries and departments with some part to play in environmental management.

10.3 Principles of Zimbabwe's environmental law reform

In leading the environmental law reform process, the Ministry of Mines, Environment and Tourism outlined the following ten principles that must form the basis for the new environmental law:

- i) The way we use the environment and natural resources for our development should enhance our ability and that of future generations to develop;
- ii) Our environment should be managed in a way that takes consideration of how our economic, social, cultural and natural environments are related;
- iii) It is better to manage the environment by seeking to prevent harm rather than to correct the damage after it has already been done;
- iv) Realistic pollution standards must be set to guide us when we monitor and assess our environment's ability to support us now and in future;

- v) Laboratories that help us to measure the quality of our environment should be of a high standard;
- vi) Penalties must be high enough to stop those who cause damage to the environment to stop doing so and they must be made responsible for correcting it. Those who avoid causing harm to the environment should be rewarded as a way of encouraging others to do the same;
- vii) All Zimbabweans should have the constitutional right to a clean and healthy environment and share the responsibility of keeping it that way;
- viii) The different ministries and departments responsible for managing the environment should work together in a way which is effective and which takes consideration of the relation between the different aspects of the environment;
- ix) The public must be involved in managing the environment;
- x) Zimbabwe's environmental law should recognize the requirements of international agreements to which the Government is party.

These principles formed the basis for the draft Environment and Natural Resources Management Bill that was the subject of this research.

11. Provisions of the Draft Environment and Natural Resources Management Bill that have a Bearing on CAMPFIRE

There are a number of provisions in the draft Bill that have a direct bearing on the CAMPFIRE programme. Some sections contained under Parts II, III, IV and VII are particularly relevant and warrant closer attention.

Part II of the draft Bill contains general principles and policy for sustainable management of the environment and natural resources in the country on the basis of which the draft Bill has been developed. Section 4 provides for the right to a clean environment for every individual as well as the right to have the environment protected for the benefit of present and future generations. The principle of inter-generational equity in the use of environmental resources is thus enshrined in the Bill. Section 4(b), (i) and (ii) provide for the need to take "measures that, (i) promote conservation, and (ii) secure ecologically sustainable management and use of natural resources while promoting justifiable economic and social development." This provision is significant in that the concept of sustainable use is formally recognised in the country's environmental law in the context of ecological sustainability. This is the basic principle of the CAMPFIRE programme.

Section 6 of the draft Bill deals with "Matters of National Importance," regarding environment and natural resources management. One of the most important elements of this section is 6(e):

"Encouraging the participation of all Zimbabweans in the making of decisions that affect the environment, including in the development of policies, programmes, plans and processes for the management of the environment."

This is recognition of the importance of community participation in decisions regarding environment and natural resources management, a key principle of CAMPFIRE.

Part III of the draft bill deals with the administration of the proposed Act. It defines the powers of the Minister, establishes and defines the powers, qualifications and terms of office of the Environment and Natural Resources Board, and also establishes and defines duties of the office of the Director of Environment and Natural Resources. Most significantly with respect to the implementation of CAMPFIRE, this part also provides for the appointment of Appropriate Authority for purposes of natural resources management.

Section 37 under this part provides for the appointment of appropriate authorities by the Minister. The Minister may appoint any person to be an 'Appropriate authority' for the purpose of managing natural resources occurring within such person's area of jurisdiction as may be specified in a notice. This provision does not limit 'Appropriate authority' status only to a local authority like a Rural District Council. Significantly, sub-section 2 of this section states:

"For the purpose of this Act, Appropriate Authority shall include the right to benefit from the management of natural resources and an obligation for sustainable management of natural resources under the jurisdiction of an Appropriate Authority" (Emphasis added).

This is another key CAMPFIRE principle that is also given legal backing. However, in addition to the right to benefit and an obligation for sustainable management, it is desirable, based on many research conclusions as discussed under the tenure and institutions sections of the above report, to also include the right for rule setting (inclusion/exclusion rights) by the Appropriate Authority.

Section 38 defines conditions under which Appropriate Authority status may be revoked. This is done where the Minister determines that management of natural resources by the Appropriate Authority is not in the best interest of conservation or current environmental policy. The Minister's decision may be contestable in the Administrative Court.

A progressive addition in the draft Bill is section 39 that provides for community status as Appropriate Authority. Section 39 (1) states:

"The Minister shall grant Appropriate Authority status to a community to manage an Environmental Protection Area or any other area, provided that such community can demonstrate to the satisfaction of the Board that –

- (a) in respect of areas other than an Environmental Protection Area, the geographical area of jurisdiction has been sufficiently identified;*
- (b) the inhabitants have constituted themselves into a Committee that is representative of the land holders;*
- (c) the Committee is capable of sustainably managing the environmental resource of the area;*
- (d) the proposed Committee is capable of managing funds and has an appropriate mechanism for ensuring the equitable distribution of benefits arising from environmental management; and*
- (e) the Committee has received the consent of the Local Authority responsible for natural resources and environment in the area."*

This provision seeks to uphold an important principle that communities should be given rights to use and benefit from natural resources and this principle forms the basis of what is considered to be a successful CAMPFIRE experiment in sustainable natural resources management and use. However, the revocation of Appropriate Authority status as provided for under Section 38 would appear to be retrogressive. It may be argued, however, that the perception created by revoking Appropriate Authority status is that resource management is a central responsibility that is only given to communities at the whim of the minister through granting of Appropriate Authority status. This perception tends to remove proprietorship over the resources from communities to central government and runs contrary to the fundamental CAMPFIRE principle of proprietorship lying with the producer communities. In essence, Appropriate Authority status should not be something that can be withdrawn as a form of punishment for mismanaging resources by communities. It is only logical that by virtue of their relationship to their resource base, it is the communities' primary responsibility to sustainably manage and use their resources.

Inherent in provisions under Section 39 is the desirability of a clearly defined geographical area under the jurisdiction of a “community” as well as the capacity of the “community” for natural resource and financial management. A demonstration of these two is a prerequisite to the granting of Appropriate Authority status to the “community”. While the definition and demarcation of geographical boundaries may be easily done, it is the natural resource boundaries that will not necessarily follow such geographical boundaries. Secondly, the definition of a “community” is not given in this draft Bill.

The interpretation of this section is best made in conjunction with the Traditional Leaders Act (Chapter 29:17). In terms of this Act, an ideal producer community for CAMPFIRE purposes, in cases where there will be an adequate resource base, would be the village assembly. The “community” in this case would, therefore, be the village assembly. The assembly brings together all adult members of the village under the leadership of the village headman. Section 23 of the Traditional Leaders Act also makes provision for villages to be surveyed for the purpose of boundary demarcation that must appear by way of maps. This demarcation of village boundaries would appear to meet the first requirement for the granting of Appropriate Authority status to the village assembly as the “community” in terms of Section 39 of the draft Bill. The second criteria for the granting of Appropriate Authority to the community is the capacity consideration with respect to sustainable natural resources management, use, benefit sharing and financial management. The community will initially depend on outside help for capacity building in these areas. This should be the focus of the CAMPFIRE Association and its partners.

Section 24 of the Traditional Leaders Act makes provision for village registration certificates to be issued to each village, through its village head, and settlement permits to the head of each household. These registrations would appear to be aimed at fostering group identity within the village that would be important in determining inclusion/exclusion rights that are so important in common property resource management regimes.

With respect to boundaries, while it may be possible to demarcate geographical boundaries, this is not necessarily true regarding natural resource/ecosystem boundaries. Natural resource boundaries will inevitably span more than just one community or village jurisdictional area. The granting of Appropriate Authority as provided for in the draft Bill is not clear on this issue. It may be necessary to consider co-management arrangements for resources spanning more than one defined Appropriate Authority area. The situation becomes even more complex when it comes to Appropriate Authority over “fugitive” resources. These are resources that are not fixed but move from one area to another. Some wildlife species, for example, will range across the jurisdiction of two or more producer communities and this situation tends to pose problems with respect to appropriate management institutions. This situation necessitates a clear definition of linkages among the producer communities and local and national authorities that have a monitoring responsibility over natural resources. Setting of quotas, for instance, may be done in close consultation.

Part VII of the draft Bill makes provision for environmental planning and natural resources conservation. Sections 115 and 116 make preparation of national and local environmental action plans mandatory. In both cases the emphasis is on participatory planning. With respect to local level planning, an opportunity is provided for CAMPFIRE to position itself and influence the incorporation of fundamental CAMPFIRE principles in such plans.

Section 117 designates every local authority as the Appropriate Authority for the control and management of natural resources occurring within the local authority limits of its jurisdiction. The local authority is also given powers to make by-laws for purposes of sustainable management of natural resources. This section needs further clarification. Section 39 provided for Appropriate Authority status over natural resources management to communities. The Appropriate Authority to be granted to local authorities needs to be further defined. Apart from a monitoring responsibility over those resources under the management of communities on a common property regime, the local authority might also have responsibility over those resources that span more than

two local community jurisdictions as well as over fugitive resources. Thus section 117 needs to be reconciled with section 39.

Section 117 (3) gives powers to local authorities to make by-laws on natural resources management. This section does not, however, provide for participation of communities in by-law formulation and policing. A number of communities in CAMPFIRE districts have managed to develop community by-laws that they have policed quite effectively. Legislation should thus allow communities to participate in the formulation and policing of by-laws.

Section 120 of the draft Bill provides for the declaration of Environmental Protection Areas, other than the Parks and Wildlife Estate or Forest Area, on the recommendation of an Appropriate Authority, including a community as Appropriate Authority. Section 121 gives the purpose of an environmental protection area as:

- “(1) The purpose for which an environmental protection area may be constituted under section one hundred and twenty (120) of this Act shall be to establish managed resource protected areas –*
- (a) to support the sustainable management of the environment and natural resources of the area; and*
 - (b) to ensure equitable sharing of the benefits arising from the sustainable management of the protected area, for the enjoyment and benefit of the persons and communities residing therein and the benefit of future generations.*
- (2) Without detracting from the generality of subsection (1) the enjoyment of, and benefit from an environmental protection area shall include spiritual, scientific, educational, recreational, tourism and economic benefits.”*

This provision of the draft Bill is significant in as far as it makes it possible to define resource boundaries that will limit access to resource use and benefit sharing to community members. CAMPFIRE can use this provision for a number of community initiatives, including eco-tourism ventures and other resource uses.

Preparation of an environmental protection plan is provided for in section 124 and will follow the declaration of an environmental protection area.

An important issue raised under section 8 of this report above is the gender question. Gender differentiation has had an impact on the implementation of CAMPFIRE as observed by Nabane (1994). The draft bill does not make specific reference to the need for gender equity in natural resource management. However, it is implied under section 6(e) of the draft bill. This section addresses what are considered matters of national importance in natural resources management. Section 6(e) reads:

“In achieving the purpose of this act, all persons exercising functions and powers under it, or other legislation listed in the Second Schedule or under any other law, in relation to managing the use, development, and protection of natural resources shall recognize the following matters of national importance:

... encouraging the participation of all Zimbabweans in the making of decisions that affect the environment, including in the development of policies, programmes, plans and processes for the management of the environment.”

This section is too general and there will be need to recognise gender imbalances and to have the concept of gender equity specifically provided for in law for purposes of sustainable management and use of natural resources.

12. Issues Raised by Stakeholders during the Research

A number of stakeholders were interviewed during the research and raised a number of issues that need to be considered in the context of implementing CAMPFIRE. Some of the issues raised may be included in the context of the current environmental legislative development process. Some have already been included in the draft Bill discussed above. Others are of an administrative nature and may be referred to the appropriate authorities for their consideration. The following is a summary of some of these issues raised by the stakeholders during this research:

1. In considering the draft bill, there is need to acknowledge the Traditional Leaders Act of 1998 and its provisions in order to avoid conflict. It is important to note that there are provisions of this Act that have a direct impact on community based natural resources management. This issue has been discussed under section 10 above, especially with respect to institutions established under the Act. The village assembly as the lowest local government institution at community level is quite relevant to the CAMPFIRE activities;
2. It was generally recognised that the multiplicity of environmental legislation currently prevailing in the country does not augur well for effective environment and natural resources management. There is a need to rationalise all the legislation under an umbrella legislation;
3. The question of incentives is critical to the successful implementation of CAMPFIRE and as such there is need to make provision for increased allocation to communities from CAMPFIRE revenues;
4. There is a need to make statutory provision for the devolution of authority, not only to Rural District Councils, but also to communities. Such Appropriate Authority needs to be granted for all natural resources and not just wildlife. The proposed granting of Appropriate Authority status to communities in terms of section 39 of the draft Bill as discussed under section 10 above appears to take this concern into account. However, it is the operational modalities for such Appropriate Authority status that merits further consideration;
5. The issue of rights of inclusion and exclusion in the context of common property resources managed communally needs to be clearly defined;
6. Traditional leadership and its role in community based natural resources management needs to be given recognition in law;
7. There is a need to revisit the Mines and Minerals Act with a view to allowing both Rural District Councils and local communities to benefit from mineral exploitation in their respective areas;
8. Benefits from commercial logging in Rural Council areas have tended to accrue to Rural District Councils. Direct benefits to communities by way of a percentage of total revenues would provide a useful incentive to such communities to protect indigenous forests;
9. Stakeholders consulted were unanimous that there is a need to treat all resources in the same manner that wildlife has been treated under the CAMPFIRE programme i.e. surrounding communities should benefit from managing these resources. However, legislation is required to effectively address potential unsustainable use of such resources. Cases sighted include gold panning and wood carving which are going on uncontrolled;
10. The issue of natural resources by-laws was commented upon widely. Some districts visited during the research have developed such by-laws. It is generally felt that currently, natural resources by-laws are drafted and implemented by RDCs without much participation of communities. RDCs themselves lack the capacity to enforce such by-laws. Where communities have participated in the drafting of such by-laws enforcement has often been successful. In some areas CAMPFIRE committees through game scouts and guards have been

effective in enforcement. However, some of the committees have been demotivated by the small fines imposed on offenders and also by the perception that police authorities do not take some of the offences seriously. Even where the offenders have been fined, these fines accrue to the national treasury and not to the local communities that have to live with the problem;

11. The issue of natural resources by-laws goes hand in hand with the question of trans-boundary natural resources. The problem arises where one district has such by-laws and an adjacent one does not. It is felt that the law must make provision for trans-district collaboration in natural resources management;

The issues enumerated above originating from stakeholder consultation form the basis of recommendations that are made below.

13. Recommendations

This research has established that there are certain fundamental CAMPFIRE principles that the CAMPFIRE Association and its partners need to lobby for to ensure that these principles are not lost in the current environmental law reform process. In order to strengthen the programme, there is need to make legislative provisions that support these basic principles.

Recommendations made in this section fall into two categories. The first category deals with those issues that it is necessary to make provision for in the current environmental law reform process. Some of these issues may already be in the present draft Environment and Natural Resources Management Bill that is going through the drafting stage. However, it is necessary to ensure that these principles are not lost up until the Bill has been enacted into law following parliamentary approval.

The second category of recommendations are those that are of an administrative nature. These issues do not necessarily have to be incorporated into law, but are those issues that the Campfire Association and its partners need to lobby for among different authorities. Such administrative issues are important in as far as they will strengthen the CAMPFIRE programme as well as facilitate empowerment of communities in natural resources management.

13.1 Legislative provisions

It is important for the benefit of the CAMPFIRE programme to ensure that the following principles are provided in law:

The principle of devolution of Appropriate Authority status to producer communities is fundamental to the CAMPFIRE programme. It is therefore necessary to ensure that this principle is not lost sight of during the current environmental law reform process. Appropriate authority should be viewed in the broader context of all natural resources management, where resource user groups can be identified, and not limited to just wildlife resources. In line with this principle, related legislation such as the Forest Act, the Parks and Wildlife Act and the Mines and Minerals Act will need to be amended to provide for sustainable resource use by communities. Giving Appropriate Authority status to producer communities should not be construed to mean total abdication of the Rural District Council's responsibility over natural resources management. Instead, the RDC would still be the Appropriate Authority with respect to a regulatory, monitoring and supervisory role over natural resources management. The RDC role becomes even more critical in the case of fugitive resources like wildlife that tend to range over many producer community boundaries. As such issues of quota setting and supervision of hunting concessions, for instance, would require close involvement of producer communities and the RDC, as well as the Department of National Parks and Wildlife Management;

One of the major recommendations of the 1992 Commission on Appropriate Agricultural Land Tenure Systems was the continuation of the communal tenure system and hence the common property resource management regime. Sustainable common property resource management depends largely on the ability to define inclusion/exclusion rights and to establish a strong authority system within defined resource boundaries. Institutions responsible for enforcement of such rights need to be clearly defined and adequately empowered for the purpose. The new law needs to provide for the establishment and/or recognition of such institutions. The role of traditional leaders in common property resource management needs to be recognised in the context of the lower level local government institutions that were established in terms of the Traditional Leaders Act. The Village assembly established in terms of that Act, the boundaries of which will be defined and shown by means of maps, and led by the traditional leadership structure is an institution that could play a vital enforcement role in the common property resource management regime. Appropriate authority status at community level could thus be vested in this legally constituted institution;

As much as possible, village boundaries could be defined on the basis of resource boundaries. The CAMPFIRE Association and its partners in the CSP could assist the Ministry of Local Government and National Housing with developing appropriate guidelines for defining resource boundaries. However, where this is not possible, the law needs to provide for co-management arrangements among neighbouring villages, Rural District Councils, and other authorities within common resource boundaries;

The question of incentives is fundamental to the CAMPFIRE concept. As such, it is commendable that the proposed legislation provides for this under section 135. However, in terms of benefit sharing, it might be useful if the law recognised the need for the larger share of revenues from CAMPFIRE proceeds accruing to communities that are responsible for managing the resource;

The proposed legislation provides for the establishment of Environmental Protection Areas. A local authority or a lower level community institution such as a village assembly may establish an environmental protection area for purposes of providing for an effective and sustainable resource management regime within the area. This calls for development of by-laws that provide for sustainable management and use of resources within the protected area. The law needs to empower communities to develop their own by-laws, under the guidance of the local authority and technical personnel that may be available to provide such advice. In the final analysis, such by-laws must be seen to be community by-laws developed and enforced based on a consensus within the respective community.

The above matters need to be provided for in the proposed legislation for purposes of strengthening the CAMPFIRE concept as a viable resource management option. However, as will be discussed under section 13 below, the legislative process in the country is such that by the time the final legal draft gets to parliament, some of the above provisions may have been lost in the process. A vigorous campaign will therefore need to be launched to ensure that the law fully empowers communities in their resource management responsibility.

13.2 Administrative changes necessitated by provisions of the proposed legislation

The draft Environment and Natural Resources Management Bill and the recently enacted Traditional Leaders Act warrant a review of administrative arrangements for the implementation of the CAMPFIRE programme. The CAMPFIRE Association and its partners might need to revisit some of these issues. In particular, it is recommended that the following be considered:

1. Sub-district structures created in terms of the Traditional Leaders Act warrant a review of current CAMPFIRE committee structures. An excellent opportunity exists for CAMPFIRE to work with ward/village communities within officially recognised structures. One of the reasons that CAMPFIRE established some of the structures that it did was that some of the key stakeholders that were critical to the implementation of CAMPFIRE were somewhat

sidelined in the former WADCO/VIDCO structures. This was particularly true of the traditional leadership. There were often conflicting roles and attitudes at grassroots level between political and traditional leadership structures. Most of these conflicts emanated from the legally undefined roles of the two structures with regards to natural resources management. The establishment of village and ward assemblies is basically a fusion of the political and traditional leadership structures with more prominence given to traditional leadership. VIDCOs and WADCOs become sub-committees of the village and ward assemblies respectively. Working through these structures will not only see the strengthening of these community institutions' natural resources management capacities but also an integration of the CAMPFIRE concept in development planning at district and sub-district levels. This therefore means that current CAMPFIRE structures will be subsumed under these new local government structures. It would be useful if people currently in these CAMPFIRE committees formed the core of the new VIDCOs and WADCOs;

2. There is need to build the capacity of both ward and village assemblies in natural resources management. These are the institutions that will be important in the enforcement of common property resource use rights within defined limits. Particular attention will need to be given to developing the capacity of the traditional leadership, as head of both the village and ward assemblies, on their role in natural resources management;
3. These new institutions need to be assisted in developing constitutions and rule making guidelines as regulating mechanisms for resource management and utilisation;
4. It has been observed that RDCs have been reluctant to devolve decision making, planning and management authority to sub-district, "producer community" level, (ward and village) (King, 1994). One way to resolve this problem would be to educate RDC councillors about CAMPFIRE principles. If councillors were better informed about the programme and its principles, it would make them understand the desirability of devolution. Accordingly, it is recommended to invest some resources in educating councillors about CAMPFIRE and its principles;
5. This research established that the process of quota setting with respect to wildlife resources was the same in all CAMPFIRE districts visited. The process begins with community meetings at village level where the communities analyse and assess the wildlife populations in their respective areas and then decide on quotas. The same is done at ward and district level. The agreed quota is then submitted to the Department of National Parks and Wildlife Management at national level where a final quota is approved. Because communities are not represented at the national level where a final quota is approved, there have often been conflicts between CAMPFIRE districts and National Parks on quotas that are finally approved. The feeling has been that decisions by the Department of National Parks and Wildlife Management would appear to undermine the participation of local communities in quota setting. The intervention of that Department in quota setting is understandable given the fugitive nature of wildlife resources. It is, however recommended that communities be represented, through their respective RDCs, in quota setting at national level in order to allow local authorities to appreciate the rationale for the final quotas set;
6. Wild animals, especially elephants, often cause a lot of problems to communities including being a direct threat to human life. However, when such situations arise the RDC has to seek authority from the Provincial Warden to kill the problem animal. Due to location difference, it may take a few days before permission is received by which time a lot more damage would have been done. Problem Animal Control (PAC) is directly related to the problem of devolution of authority. This problem can be solved at the local level by considering it in the context of integrated natural resources management strategy as designed and implemented by the communities themselves. It is thus recommended that decisions on PAC be decentralised to allow RDCs and their communities to address this issue in the context of their natural resources management strategies. National Parks, through its staff at district level would

always be there to provide the necessary authority and/or advice. The CAMPFIRE Association, together with other CAMPFIRE Service Providers (CSP) will need to concentrate on capacity building at the district and sub-district levels;

7. At the moment some CAMPFIRE infrastructure projects are required to undergo Environment Impact Assessment (EIA) processes. The RDCs and their communities lack the capacity to undertake EIAs. This capacity is also limited among most extension workers in the communities. The only option for communities would be to engage private consultants who are generally expensive. It is recommended that where projects of a similar nature are undertaken countrywide, it might be useful to conduct class EIAs for such projects.

In light of the above recommendations, it is important for the CAMPFIRE Association to take a two-pronged position. First, there is a need to lobby government on the fundamental CAMPFIRE principles that should be included in the draft legislation that is currently being prepared. Some of these principles are given above. Secondly, there is need for CAMPFIRE districts to align their activities and structures with local government structures established in terms of the Traditional Leaders Act. The points of intervention with respect to the legislative development process are indicated under section 14 below.

14. Current Status and the Legislative Process of Draft Bill

As earlier indicated in this report, the draft Environment and Natural Resources Management Bill has gone through a series of consultations that lasted more than two years. The first draft was produced in March 1998 and was subjected to further public scrutiny. This resulted in the current omnibus version of the Bill. The Ministry of Mines, Environment and Tourism has, at the time of writing this report, submitted its layman's draft Bill for legal drafting by the Attorney General's Office.

The first legal draft from the Attorney General's office will be submitted to the Ministry of Mines, Environment and Tourism for endorsement before it is submitted to Cabinet for approval. After cabinet has approved the bill, it will then be tabled before parliament for debate and approval before it is submitted to the President for signing into law.

During the process of legal drafting by the Attorney General's office, the legal draft Bill from that office will not necessarily be in the same form as the layman's draft submitted by the Ministry of Mines, Environment and Tourism. It is also possible that some provisions that are in the Ministry of Mines, Environment and Tourism's draft may not appear in the final legal draft by the Attorney General's office. It is in this process that some key CAMPFIRE principles might be left out of the draft law. Where such principles have been left out of the legal drafting process, there are basically two points of intervention through which a CAMPFIRE Association lobby might wish to press for the inclusion of such principles.

The first point of intervention would be through the Minister of Mines, Environment and Tourism after the Minister has received the first legal draft from the Attorney General's office. If the Minister supports the inclusion of those principles, the draft is then referred back to the Attorney General's office for inclusion of those principles. It is thus important for the CAMPFIRE Association to keep track of this process in order to make timely interventions.

The second point of intervention in the event that the CAMPFIRE Association has missed the first point, would be a lobby of parliamentarians before the draft Bill is tabled for debate in parliament. Parliamentarians would then be in a position to introduce the proposed amendments that would see the inclusion of those principles that will have been left out. In developing an effective lobby of parliamentarians, it will be useful to initially target those MPs representing constituencies within CAMPFIRE districts. These MPs would then assist in gaining support from other non-CAMPFIRE MPs who might be sympathetic to the CAMPFIRE principles.

15. Resources Required to Implement Recommendations

Resources will be required to implement the following activities arising from recommendations made above:

- Seminars for parliamentarians on the CAMPFIRE programme and its principles and the need for legislative empowerment of communities for natural resources management;
- Capacity building for village and ward assemblies and their respective development committees on CAMPFIRE principles and community based natural resources management. The idea should be to strengthen these institutions for the management of common property resources within a given constituency;
- Seminars for traditional leaders on their role in natural resources management;
- Awareness workshops for councillors in CAMPFIRE districts to make them appreciate the CAMPFIRE principles and the need for devolution of management authority over natural resources to sub-district level.

The above activities need investment in both human and financial resources if a successful lobby on the proposed legislation is to be launched.

16. Conclusion

This report has discussed the background to CAMPFIRE as a viable option for sustainable community based natural resources management. The question of resource tenure in the Zimbabwean context has also been discussed together with an analysis of various natural resource management regimes. From the literature, as well as from the recommendations made by the 1992 Commission on Appropriate Agricultural Land Tenure Systems, it has been concluded that communal tenure will continue for some time in Zimbabwe. So will the common property regime of natural resource management within the communal tenure system.

In the light of the above, it becomes useful to put more emphasis in strengthening institutions for the management of common property resources, including the enforcement of inclusion/exclusion rights by communities within defined resource user boundaries. In the light of institutional changes provided for by the recently promulgated Traditional Leaders Act (ward and village assemblies), an opportunity exists for CAMPFIRE to work within these local government structures, strengthening them to meet the challenges of sustainable natural resources management. Legislative and administrative measures will be necessary in order to empower communities to fully take on the management of their resources. The question of devolution of Appropriate Authority to communities as provided for in the draft Environment and Natural Resources Management Bill currently under consideration is fundamental to the fulfilment of the overall objectives of CAMPFIRE.

References

- Bromley, D.W.** (1992) "Property Rights as Authority Systems: The role of rules in resource management." In: *Proceedings of the Conference on Common Property Resource Management*. Washington DC: National Academy Press.
- Bromley, D. and M. Cernea** (1990) The Management of Common Property Natural Resources: Some Conceptual and Operational Fallacies. World Bank Discussion Paper 57, Washington DC.
- Cliffe, L.** (1986) Policy Options for Agrarian Reform in Zimbabwe: A Technical Appraisal. FAO, Rome.
- Fortmann, L. and C. Nhira** (1992) Local Management of Trees and Woodland Resources in Zimbabwe: A Tenurial Niche Approach. - (CASS Occasional Paper Series - CPN.42). Centre for Applied Social Sciences, University of Zimbabwe.
- King, L. A.** (1994) Inter-organizational Dynamics in Natural Resources Management: A Study of CAMPFIRE Implementation in Zimbabwe. - (CASS Occasional Paper Series - CPN.60). Centre for Applied Social Sciences, University of Zimbabwe.
- Murombedzi, J. C.** (1990a) Communal Land Tenure and Common Property Resource Management: An Evaluation of the Potential for Sustainable Common Property Resource Management in Zimbabwe's Communal Areas. (CASS Occasional Paper Series – CPN.17). Centre for Applied Social Sciences, University of Zimbabwe.
- Murombedzi, J. C.** (1990b) The Need for Appropriate Local Level Common Property Resource Management Institutions in Communal Tenure Regimes. (CASS Occasional Paper Series – CPN.18). Centre for Applied Social Sciences, University of Zimbabwe.
- Murombedzi, J. C.** (1994) The Dynamics of Conflict in Environmental Management Policy in the Context of the Communal Areas Management Programme for Indigenous Resources (CAMPFIRE). D. Phil. Thesis, Centre for Applied Social Sciences (CASS), University of Zimbabwe.
- Martin, R. B.** (1986) Communal Areas Management Programme for Indigenous Resources (CAMPFIRE). Revised version. Department of National Parks and Wildlife Management, Govt. of Zimbabwe, Harare, 110 pp.
- Murphree, M. W.** (1991) Communities as Institutions of Resource Management. (CASS Occasional Paper Series – CPN.27) Centre for Applied Social Sciences, University of Zimbabwe.
- Murphree, M. W. and D. H. M. Cumming** (1991) Savannah Land Use: Policy and Practice in Zimbabwe. (CASS/WWF Joint Working Paper Series No. 1; & CPN.26) Centre for Applied Social Sciences, University of Zimbabwe.
- Nabane, N.** (1994) A Gender Sensitive Analysis of a Community Based Wildlife Utilization Initiative in Zimbabwe's Zambesi Valley. (CASS Occasional Paper Series – CPN.61). Centre for Applied Social Sciences, University of Zimbabwe.
- Nhira, C.** (1990) "Integrated Natural Resource Management in Communal Areas: Problems and Opportunities in Kanyati Communal Land," In: Cousins, B. (Ed.). Institutional Dynamics in Communal Grazing Regimes in Southern Africa: Proceedings of a Workshop Held in Harare, Zimbabwe, December 1990; pp.125-128. Centre for Applied Social Sciences (CASS), University of Zimbabwe.

- Scoones, I. C. and F. Matosé** (1993) "Local Woodland Management: Constraints and Opportunities for Sustainable Resource Use," In: P.N. Bradley and K. McNamara (Eds.). Living With Trees: Policies for Forestry Management in Zimbabwe. (World Bank Technical Paper Number 210). World Bank, Washington D.C.
- Sithole, B. and P. N. Bradley** (1995) Institutional Conflicts Over the Management of Communal Resources in Zimbabwe. Stockholm Environment Institute, Stockholm.
- Smith, R. J.** (1981) "Resolving the Tragedy of the Commons by Creating Private Property Rights in Wildlife Management." *CATO Journal*, 1: 439-68.
- Thomas, S. J.** (1992) "Indigenous Woodlands and CAMPFIRE: Complimentarities from Collaboration." Paper presented at the SAREC/Zimbabwe Forestry Commission Symposium: Ecology and Management of Indigenous Forests in Southern Africa, Victoria Falls, July 1992. Zimbabwe Trust, Harare.
- Wade, R.** (1987) "The Management of a Common Property Resource: Finding a Co-operative Solution." *The World Bank Research Observer*, 2 (July): 219-234.
- Zimbabwe, Govt. of** (1992) Government of the Republic of Zimbabwe National Report to the United Nations Conference on Environment and Development, Brazil. Ministry of Mines, Environment and Tourism, Harare.
- Zimbabwe, Govt. of** (1994) Report of the Commission of Inquiry into Appropriate Agricultural Land Tenure Systems, Vol. 1. (Ministry of Lands and Agriculture, Harare).



This work is licensed under a
Creative Commons
Attribution – NonCommercial - NoDerivs 3.0 License.

To view a copy of the license please see:
<http://creativecommons.org/licenses/by-nc-nd/3.0/>

This is a download from the BLDS Digital Library on OpenDocs
<http://opendocs.ids.ac.uk/opendocs/>