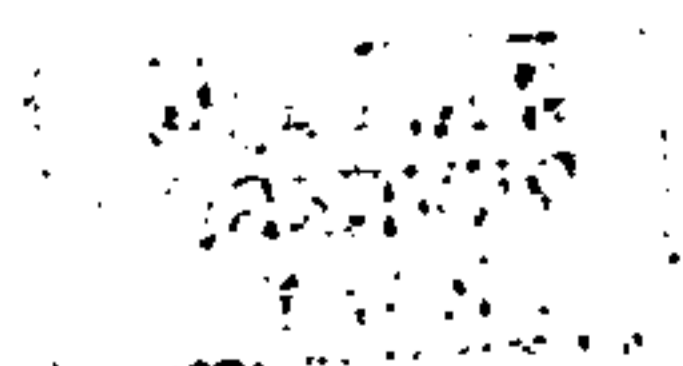


A Re-Interpretation of the Late Bronze Age
Metalwork Hoards of Essex and Kent

Volume III of III: Kent

C. E. Louise Turner

Submitted to the University of Glasgow in February, 1998 for the degree of
Doctor of Philosophy, following research undertaken at the the Department of
Archaeology, University of Glasgow



List of Hoards

All Hallows I (Little Coombe Farm) (Ref. No. 12).	.	.	1
All Hallows II (Home Wood Farm) (Ref. No. 13)	.	.	16
Aylesford (Ref. No. 14)	.	.	27
Bexley Heath (Ref. No. 15)	.	.	30
Borstal (Ref. No. 16)	.	.	59
Cliffe-at-Hoo (Ref. No. 17)	.	.	79
Dartford (Ref. No. 18)	.	.	82
Minnis Bay (Ref. No. 19)	.	.	93
Minster (Ref. No. 20)	.	.	125
Stoke-at-Hoo (Ref. No. 21)	.	.	186
Sturry (Ref. No. 22)	.	.	204
Whitstable (Ref. No. 23)	.	.	211

List of Illustrations

Note: All illustrations are the work of the author, and were undertaken with reference to the original objects. An accurate representation of the object has been sought at all times, but certain features associated with manufacture, use, and reduction such as grinding marks, hammer marks, etc. may have been exaggerated for the purposes of ensuring a clear demonstration of observations referred to in the accompanying text.

Fig. 1	The All Hallows I Hoard (Ref. No. 12): Complete Socketed Axes	9
Fig. 2	The All Hallows I Hoard (Ref. No. 12): Socketed Axe Fragments (i)	10
Fig. 3	The All Hallows I Hoard (Ref. No. 12): Socketed Axe Fragments (ii)	11
Fig. 4	The All Hallows I Hoard (Ref. No. 12): Winged Axes	12
Fig. 5	The All Hallows I Hoard (Ref. No. 12): Weaponry and Small Tools	13
Fig. 6	The All Hallows I Hoard (Ref. No. 12): Ingot Metal (i)	14
Fig. 7	The All Hallows I Hoard (Ref. No. 12): Ingot Metal (ii)	15
Fig. 8	The All Hallows II Hoard (Ref. No. 13): Socketed Axes	23
Fig. 9	The All Hallows II Hoard (Ref. No. 13): Socketed Axe Fragments and Small Tools	24
Fig. 10	The All Hallows II Hoard (Ref. No. 13): Sword Fragments	25
Fig. 11	The All Hallows II Hoard (Ref. No. 13): Weapons and Miscellaneous Items	26
Fig. 12	The Aylesford Hoard (Ref. No. 14)	29
Fig. 13	The Bexley Heath Hoard (Ref. No. 15): Complete Socketed Axes (i)	46
Fig. 14	The Bexley Heath Hoard (Ref. No. 15): Complete Socketed Axes (ii)	47
Fig. 15	The Bexley Heath Hoard (Ref. No. 15): Complete Socketed Axes (iii)	48
Fig. 16	The Bexley Heath Hoard (Ref. No. 15): Complete Socketed Axes (iv)	49
Fig. 17	The Bexley Heath Hoard (Ref. No. 15): Complete Socketed Axes (v)	50
Fig. 18	The Bexley Heath Hoard (Ref. No. 15): Socketed Axe Fragments (i)	51
Fig. 19	The Bexley Heath Hoard (Ref. No. 15): Socketed Axe Fragments (ii)	52
Fig. 20	The Bexley Heath Hoard (Ref. No. 15): Small Tools, Weaponry and Miscellaneous Items	53
Fig. 21	The Bexley Heath Hoard (Ref. No. 15): Ingot Metal (i)	54
Fig. 22	The Bexley Heath Hoard (Ref. No. 15): Ingot Metal (ii)	55
Fig. 23	The Bexley Heath Hoard (Ref. No. 15): Ingot Metal (iii)	56
Fig. 24	The Bexley Heath Hoard (Ref. No. 15): Ingot Metal (iv)	57
Fig. 25	The Bexley Heath Hoard (Ref. No. 15): Ingot Metal (v)	58
Fig. 26	The Borstal Hoard (Ref. No. 16): Socketed Axes	71
Fig. 27	The Borstal Hoard (Ref. No. 16): Socketed Axe Fragments (i)	72
Fig. 28	The Borstal Hoard (Ref. No. 16): Socketed Axe Fragments (ii)	73
Fig. 29	The Borstal Hoard (Ref. No. 16): Knife and Sword Fragments	74
Fig. 30	The Borstal Hoard (Ref. No. 16): Weapons and Miscellaneous Items	75
Fig. 31	The Borstal Hoard (Ref. No. 16): Casting Debris and Ingot Metal (i)	76
Fig. 32	The Borstal Hoard (Ref. No. 16): Ingot Metal (ii)	77
Fig. 33	The Borstal Hoard (Ref. No. 16): Ingot Metal (iii)	78
Fig. 34	The Cliffe-at-Hoo Hoard (Ref. No. 17)	81
Fig. 35	The Dartford Hoard (Ref. No. 18): Socketed Axes	88
Fig. 36	The Dartford Hoard (Ref. No. 18): Axe, Small Tool and Weapon Fragments	89
Fig. 37	The Dartford Hoard (Ref. No. 18): Ingot Metal (i)	90
Fig. 38	The Dartford Hoard (Ref. No. 18): Ingot Metal (ii)	91
Fig. 39	The Dartford Hoard (Ref. No. 18): Ingot Metal (iii)	92
Fig. 40	The Minnis Bay Hoard (Ref. No. 19): Complete Socketed Axes	112
Fig. 41	The Minnis Bay Hoard (Ref. No. 19): Socketed Axes	113
Fig. 42	The Minnis Bay Hoard (Ref. No. 19): Socketed Axe Fragments and Socketed Chisels	114

Fig. 43	The Minnis Bay Hoard (Ref. No. 19): Winged Axes	115
Fig. 44	The Minnis Bay Hoard (Ref. No. 19): Mortising Chisels, Punches and Gouges	116
Fig. 45	The Minnis Bay Hoard (Ref. No. 19): Sickles and Knife Fragments	117
Fig. 46	The Minnis Bay Hoard (Ref. No. 19): Socketed Sword and Sword Hilt Fragments	118
Fig. 47	The Minnis Bay Hoard (Ref. No. 19): Carp's Tongue Sword Fragments	119
Fig. 48	The Minnis Bay Hoard (Ref. No. 19): Ewart Park Sword Fragments, Chape and Spearheads	120
Fig. 49	The Minnis Bay Hoard (Ref. No. 19): Bracelet Fragments	121
Fig. 50	The Minnis Bay Hoard (Ref. No. 19): Miscellaneous Objects	122
Fig. 51	The Minnis Bay Hoard (Ref. No. 19): Miscellaneous Fragments	123
Fig. 52	The Minnis Bay Hoard (Ref. No. 19): Casting Debris, Sheet Bronze and Miscellaneous Items	124
Fig. 53	The Minster Hoard (Ref. No. 20): Complete Socketed Axes (i)	161
Fig. 54	The Minster Hoard (Ref. No. 20): Complete Socketed Axes (ii)	162
Fig. 55	The Minster Hoard (Ref. No. 20): Complete Socketed Axes (iii)	163
Fig. 56	The Minster Hoard (Ref. No. 20): Complete Socketed Axes (iv)	164
Fig. 57	The Minster Hoard (Ref. No. 20): Complete Socketed Axes (v)	165
Fig. 58	The Minster Hoard (Ref. No. 20): Complete Socketed Axes (vi)	166
Fig. 59	The Minster Hoard (Ref. No. 20): Socketed Axe Fragments (i)	167
Fig. 60	The Minster Hoard (Ref. No. 20): Socketed Axe Fragments (ii)	168
Fig. 61	The Minster Hoard (Ref. No. 20): Socketed Axe Fragments (iii)	169
Fig. 62	The Minster Hoard (Ref. No. 20): Socketed Axe Fragments (iv)	170
Fig. 63	The Minster Hoard (Ref. No. 20): Socketed Axe Fragments (v) and Winged Axes (i)	171
Fig. 64	The Minster Hoard (Ref. No. 20): Winged Axes (ii)	172
Fig. 65	The Minster Hoard (Ref. No. 20): Small Tools and Sword Fragments	173
Fig. 66	The Minster Hoard (Ref. No. 20): Sword Hilt Fragments	174
Fig. 67	The Minster Hoard (Ref. No. 20): Ewart Park Sword Blade Fragments (i)	175
Fig. 68	The Minster Hoard (Ref. No. 20): Ewart Park Sword Blade Fragments (ii)	176
Fig. 69	The Minster Hoard (Ref. No. 20): Sword Blade Fragments	177
Fig. 70	The Minster Hoard (Ref. No. 20): 'Carp's Tongue' Sword Blade Fragments and Scabbard Chape	178
Fig. 71	The Minster Hoard (Ref. No. 20): Spearheads	179
Fig. 72	The Minster Hoard (Ref. No. 20): Miscellaneous Objects and Casting Debris	180
Fig. 73	The Minster Hoard (Ref. No. 20): Ingot Metal (i)	181
Fig. 74	The Minster Hoard (Ref. No. 20): Ingot Metal (ii)	182
Fig. 75	The Minster Hoard (Ref. No. 20): Ingot Metal (iii)	183
Fig. 76	The Minster Hoard (Ref. No. 20): Ingot Metal (iv)	184
Fig. 77	The Minster Hoard (Ref. No. 20): Ingot Metal (v)	185
Fig. 78	The Stoke-at-Hoo Hoard (Ref. No. 21): Socketed Axes (i)	196
Fig. 79	The Stoke-at-Hoo Hoard (Ref. No. 21): Socketed Axes (ii)	197
Fig. 80	The Stoke-at-Hoo Hoard (Ref. No. 21): Socketed Axe Fragments	198
Fig. 81	The Stoke-at-Hoo Hoard (Ref. No. 21): Small Tools, Weaponry and Decorative Fittings	199
Fig. 82	The Stoke-at-Hoo Hoard (Ref. No. 21): Mould Fragment, Casting Debris and Ingot Metal (i)	200
Fig. 83	The Stoke-at-Hoo Hoard (Ref. No. 21): Ingot Metal (ii)	201
Fig. 84	The Stoke-at-Hoo Hoard (Ref. No. 21): Ingot Metal (iii)	202
Fig. 85	The Stoke-at-Hoo Hoard (Ref. No. 21): Ingot Metal (iv)	203
Fig. 86	The Sturry Hoard (Ref. No. 22): Socketed and Winged Axes	208
Fig. 87	The Sturry Hoard (Ref. No. 22): Winged Axe, Palstave, Small Tools and Spearheads (i)	209

Fig. 88	The Sturry Hoard (Ref. No. 22): Spearheads (ii), Ferrule and Ingot Metal	210
Fig. 89	The Whitstable Hoard (Ref. No. 23): Socketed Axes	220
Fig. 90	The Whitstable Hoard (Ref. No. 23): Socketed Axe Fragments	221
Fig. 91	The Whitstable Hoard (Ref. No. 23): Winged Axes and Small Tools	222
Fig. 92	The Whitstable Hoard (Ref. No. 23): Weaponry	223
Fig. 93	The Whitstable Hoard (Ref. No. 23): Casting Debris and Ingot Metal (i)	224
Fig. 94	The Whitstable Hoard (Ref. No. 23): Ingot Metal (ii)	225
Fig. 95	The Whitstable Hoard (Ref. No. 23): Ingot Metal (iii)	226
Fig. 96	The Whitstable Hoard (Ref. No. 23): Ingot Metal (iv)	227

All Hallows I (Little Coombe Farm) (Ref. No. 12)

Grid Reference: TQ 83 77.

Current Location: British Museum, Accession Numbers 94: 8-3: 1-38. There is some confusion apparent in documents which refer to the hoards of All Hallows I and All Hallows II. In some reference material, the hoard from Home Wood Farm has been given the title 'All Hallows I' (NBI), while elsewhere it is the Little Coombe Farm hoard which appears to have this name. Since both hoards share the same museum accession number, it has been assumed that the hoard which bears the earliest numbers in the sequence is All Hallows I. This is, in fact, the hoard from Little Coombe Farm.

Context: Found 3' below the surface by workmen trenching a field on Little Coombe Farm, Kent (Wickham, 1876).

Bibliography: Burgess and Colquhoun, 1988.
Jessup, 1930.
National Bronze Index (N. B. I.).
Wickham, 1877.

Contents:-

12/01 (Acc. No. 94: 8-3: 3)

Description: Socketed axe of faceted type.

Dimensions: Length: 103mm. Cutting edge: 55mm. Weight: 158.8g.

Patina: Rough, mottled pale green and brown. Details largely obscured.

Manufacture: The mouth is well-finished, but has an uneven appearance. The seams remain prominent on the upper surface, but are no longer visible over the final c.10mm back from the cutting edge. The lower surface is similar, but the seam has been removed over the loop. The cutting edge has been well-expanded, and has a crescentic appearance.

Use: The crescentic appearance of the blade probably results from resharpening. The blade has been unevenly worn, and the cutting edge is chipped and burred. Its poor condition may, however, be exaggerated through the build-up of corrosion products.

Reduction: The object is complete and there is no evidence relating to this process.

12/02 (Acc. No 94: 8-3: 2)

Description: Socketed axe of faceted type.

Dimensions: Length: 106mm. Cutting edge: 53mm. Weight: 165.2g.

Patina: Corrosion stripped, detail largely lost.

Manufacture: The mouth seems rather uneven in appearance, with faint stumps of the feeders remaining. The seams appear to have been completely removed from the upper and lower surfaces, though this is difficult to determine as a result of the corrosion loss. The cutting edge is well-expanded, and is almost crescentic in appearance. There are possible horizontal and vertical grinding marks over the cutting edge, and possible diagonal grinding marks on the body, though details are once again difficult to determine.

Use: The blade is uneven and appears to have been badly chipped in antiquity.

Reduction: The object is complete and there is no evidence relating to this process.

12/03 (Acc. No. 94: 8-3: 4)

Description: Incomplete socketed axe, of faceted type.

Dimensions: Length (maximum): 95mm. Cutting edge: 47mm. Weight: 149.1g.

Patina: Rough olive, details obscured.

Manufacture: The upper seam has been virtually obliterated, though a slight step in the section is still visible. The lower seam is less well-finished. The cutting edge has been widely expanded.

Use: The cutting edge was badly notched and broken in antiquity, and one substantial piece has broken away. Some of the lesser damage may be partly due to recent flaking of the corrosion product.

Reduction: The mouth of the object is now missing. A slight depression and associated multiple hammer marks are visible near the break on either face.

12/04 (Acc. No. 94: 8-3: 1)

Description: Socketed axe, of 'south-eastern' type. A single interior rib is visible inside the mouth - there may be another on the opposing side, but this is barely discernible.

Dimensions: Length: 116mm. Cutting edge (maximum): 37mm. Weight: 246.1g.

Patina: Smooth grey-green, much obscured by rough pale-green/brown patches. Details almost obliterated.

Manufacture: The mouth has been well-finished. Towards the mouth the top seam is still obvious, though it has been flattened. It appears, however, to have been removed from two-thirds of the way down the body right to the cutting edge. The lower seam is similar, though some traces of the seam remain on either side of the loop. The blade is not well-expanded, although it has been subject to some expansion and is no longer in an as-cast state.

Use: One corner of the edge broke away in antiquity, and the blade is badly notched, though some of this damage seems to result from recent loss of corrosion product. The blade appears blunt along its entire length.

Reduction: The object is complete. A few shallow notches visible in one area of the upper moulding (not illustrated) are likely to have resulted from the cutting of the binding or the removal of the haft.

12/05 (Acc. No. 94: 8-3: ?5)

Description: Socketed axe, of 'south-eastern' type.

Dimensions: Length: 100mm. Cutting edge: 43mm. Weight: 162.4g.

Patina: Corrosion stripped, no details visible.

Manufacture: The mouth seems very thin and uneven, with some gaps apparent, and also cracking of the metal. This seems to be the result of a casting defect, i.e. core misalignment. The loop is incomplete, and a rounded appearance to the break at one side seems to suggest that the deformity is the result of a casting flaw. On the other side, though, the jagged condition of the metal may argue against this, but it could be argued that corrosion stripping has caused this. There is also a hole in the piece - again the edges seem rather too ragged to indicate a flaw, but this may once more be due to the removal of corrosion build-up. As a result of the corrosion loss, it is also impossible to establish the condition of the seams. Possible diagonal grinding marks can be seen on one face, and possible horizontal grinding marks occur over the cutting edge on one side (not illustrated). The cutting edge has been well-expanded.

Use: The blade appears to be unevenly worn. The edge is blunted and chipped, and some hammering is visible in one corner, a feature which may indicate resharpener.

Reduction: The object is complete. No visible indications can be associated with this phase, though it could be suggested that the hole in the face might have resulted from hammering associated with the loosening of a tightly wedged haft.

12/06 (Acc. No. 94: 8-3: 6)

Description: Socketed axe, of 'south-eastern' type.

Dimensions: Length: 73mm. Cutting edge: 32mm. Weight: 116.3g.

Patina: Corrosion stripped, no details visible.

Manufacture: Some pitting in the collar may indicate a poor casting, but may have resulted from the removal of the corrosion product. The mouth is well-finished, and the top seam is flattened but still visible until halfway down the body, from which point it has been virtually obliterated all the way down to the cutting edge. No indications of the seam remain on the underside, except in the immediate vicinity of the loop. The blade seems blunt and narrow, and may be unexpanded.

Use: Possibly unused. The edge is chipped and uneven, but this may result from the build-up and subsequent flaking-away of corrosion products. There are some possible coarse striations running across one face, but with the current state of the piece these must remain problematic.

Reduction: The object is complete, with no evidence relating to this process.

12/07 (Acc. No. 94: 8-3: 7)

Description: Mouth and upper body of 'south-eastern' socketed axe. Three ribs are visible on one side, with three furrows apparent on the other. Two opposing ribs are present in the interior.

Dimensions: Length (maximum): 62mm. Weight: 140.4g.

Patina: Bright green, details obscured.

Manufacture: One wall seems thin, a result of core misalignment. The seams are now absent over the loop, but elsewhere they remain prominent, though the excess appears to have been trimmed and flattened. Some chisel marks, visible on the stretch of seam between the loop and the body, may be linked with this process.

Use: Impossible to determine.

Reduction: There are possible traces of hammering near the break, but these seem rather finely executed to be associated with fragmentation.

12/08 (Acc. No. 94: 8-3: 16)

Description: Mouth and upper body of socketed axe, probably of 'south-eastern' type. What was probably a rectangular body section has now been extensively crushed, and a probable multiple collar moulding has now been hammered flat.

Dimensions: Length (maximum): 65mm. Weight: 216.5g.

Patina: Rough grey-green, details obscured.

Manufacture: The seams have been trimmed and flattened, but they still remain obvious over the length of the piece, with the exception of the loop. The interior is filled with soil or clay.

Use: Impossible to determine.

Reduction: This upper body fragment has been crushed along its length. As a result the metal around the mouth has split, with damage especially obvious in the areas close to the casting seams on either side. At the mouth, the section is now very distorted, but at the lower break it is less so. Here, the socket appears to be filled with clay or brick earth. Another object is visible here - a fragment of a thin blade, perhaps, or a strip of bronze, and this has been wedged in place by the crushing of the section.

12/09 (Acc. No. 94: 8-3: 62)

Description: Mouth fragment of socketed axe, of 'south-eastern' type.

Dimensions: Length (maximum): 47mm. Weight: 21.2g.

Patina: Corrosion stripped, details poor.

Manufacture: The walls seem very thin, and the interior shows a deep furrow running down its length at a point equivalent to the exterior seam. This may indicate mismatched mould valves. The mouth is uneven, with a stump of the feeder remaining. The seams have been obliterated over the loop, but are visible elsewhere, though they have largely been flattened.

Use: Impossible to determine.

Reduction: The section is distorted, but no other indications are present, i.e. hammer marks, etc. A rough hole on the lower break may indicate a casting flaw, but could also be attributable to later damage or even corrosion removal. Originally located inside 12/11 (94: 8-3: 6) from which it was presumably removed during the process of corrosion stripping.

12/10 (Acc. No. 94: 8-3: 8)

Description: Blade and lower body of socketed axe, with rectangular body section.

Dimensions: Length (maximum): 86mm. Cutting edge: 43mm. Weight: 156.1g.

Patina: Rough grey-green, details invisible.

Manufacture: The seams are completely invisible on one side, and they cannot be seen on the other for a distance of c.20mm back from the cutting edge. The cutting edge does not seem well-expanded.

Use: The edge seems reasonable, with some chipping apparent in places. This may result from later damage, i.e. recent loss of corrosion product.

Reduction: The break seems ragged, though there is little distortion to the section. There are no indications of hammering.

12/11 (Acc. No. 94: 8-3: 9)

Description: Blade fragment of socketed axe, with the socket now blocked through the insertion of smaller fragments. The body section was originally rectangular.

Dimensions: Length (maximum): 73mm. Cutting edge: 45mm. Weight: 128.8g.

Patina: A very rough grey green, with the whole surface covered by encrustation. Details obliterated.

Manufacture: No indications of core misalignment are evident in this example. The seams are visible from c.10mm back from the cutting edge, which is crescentic in appearance.

Use: The cutting edge seems chipped and uneven. Some of this damage is recent, and may be related to the flaky nature of the corrosion product, but most seems to date to antiquity.

Reduction: Fragments of other objects fill the socket (the corner of a socketed axe blade, and a possible wall fragment of socketed axe can be identified). These appear to have been inserted prior to the crushing of the axehead. Crushing has resulted in one side having been pushed inwards, and the section is now so distorted that the casting seam has now twisted around so that it lies on the same plane as the face (illustrated). Some possible hammer marks are visible on one face (not illustrated) but, due to the nature of the corrosion product, it is impossible to reach firm conclusions with regards to this. The metal is also badly cracked along the interface between one face and the adjacent side.

12/12 (Acc. No. 94: 8-3: 14)

Description: Blade fragment of faceted socketed axe.

Dimensions: Length (maximum): 54mm. Cutting edge: 46mm. Weight: 83.0g.

Patina: Very rough grey-green, with much encrustation, details totally obscured.

Manufacture: The seams are prominent but very smooth, as if hammered flat and deliberately incorporated into the finished piece. The cutting edge has been widely expanded.

Use: The cutting edge seems badly chipped, though much of this may result from later loss of the corrosion product.

Reduction: There may be indications of hammering near the break but this is difficult to confirm as a result of the corrosion build-up.

12/13 (Acc. No. 94: 8-3: 11)

Description: Blade fragment of socketed axe, with rectangular body section.

Dimensions: Length (maximum): 43mm. Cutting edge: 39mm. Weight: 93.2g.

Patina: Fairly dense grey-green covering, with some encrustation in places. Details poor.

Manufacture: The wall on one side is very thin in section, suggesting core misalignment. The casting seams have been reduced through trimming and flattening, though they remain visible on both sides.

Use: The blade seems blunt and shows little evidence of any damage. The object may have seen little, if any, use.

Reduction: There are some very tenuous hammer marks near the break on one face (illustrated).

12/14 (Acc. No. 94: 8-3: 12)

Description: Blade fragment of socketed axe, with rectangular body section.

Dimensions: Length (maximum): 44mm. Cutting edge (maximum): 40mm. Weight: 70.9g.

Patina: Rough pale green, much encrustation. Details obliterated.

Manufacture: One wall is markedly thinner in section, suggesting core misalignment. The seams are invisible on one side, but on the other encrustation is too severe for any evaluation to be made. The cutting edge is well-expanded.

Use: The cutting edge seems very chipped, but this may result from recent loss of the corrosion product.

Reduction: There is one possible minor depression in one wall, but the section shows no indications of distortion, so doubt over the validity of this evidence must remain.

12/15 (Acc. No. 94: 8-3: 13)

Description: Blade fragment of socketed axe.

Dimensions: Length (maximum): 41mm. Cutting edge: 51mm. Weight: 82.7g.

Patina: One face is copper coloured, the other is covered with a thin coating of reddish brown and mottled grey with some mild encrustation. This may have been the result of patina stripping followed by localised corrosion. No details remain where fresh metal is exposed, though there are some vague indications surviving where corrosion products are still evident.

Manufacture: There are no indications of any casting flaws. On one side, all that remains of the seam is a slight step in the section, while on the other the seam survives as a thick line that runs right up to the cutting edge, which appears to be well-expanded.

Use: The cutting edge appears blunted and burred over much of its length.

Reduction: There are possible chisel marks visible in the corrosion product on one side, and these have been exaggerated by the corrosion build-up. The other side shows lateral cracking of the metal near the break, and a slight depression towards the broken edge of the piece.

12/16 (Acc. No. 94: 8-3: 15)

Description: Blade fragment of socketed axe, with rectangular body section.

Dimensions: Length (maximum): 41mm. Cutting edge: 51mm. Weight: 96.9g.

Patina: Rough grey-green, details poor.

Manufacture: The casting seems reasonable, with no visible indications of flaws. The seams have been totally removed on both sides, and the blade is crescentic in appearance.

Use: The edge is rough, but still seems reasonable. Some of the apparent damage may result from later flaking of the corrosion product.

Reduction: There are no visible indications of hammering, and the section shows no traces of distortion. A slight bulge at the break is due to a build-up of corrosion product.

12/17 (Acc. No. 94: 8-3: 27)

Description: Butt fragment of winged axe, with a hollow section evident within the piece.

Dimensions: Length (maximum): 78mm. Weight: 73.1g.

Patina: Mottled pale green/olive. Details reasonable.

Manufacture: No traces of the casting seams remain, and the butt, too, appears neatly finished. Traces of fine hammering are visible on the wings, presumably from the process of closing these over the wooden haft.

Use: Impossible to determine.

Reduction: Some striations near the break could be small tool marks, but the section here shows no obvious distortions.

12/18 (Acc. No. 94: 8-3: 17)

Description: Butt fragment of winged axe.

Dimensions: Length (maximum): 100mm. Weight: 265.6g.

Patina: The bronze is badly corroded, and the thick patina is cracked and flaking, with large lumps of encrustation apparent. Details obliterated.

Manufacture: There is no evidence pertaining to this process.

Use: Impossible to determine.

Reduction: The upper and lower wings are missing on one side of the piece. Deliberate removal is presumed, but no clear evidence is available which supports this.

12/19 (Acc. No. 94: 8-3: 18)

Description: Body fragment of probable winged axe, now missing blade, butt and wings.

Dimensions: Length (maximum): 58mm. Weight: 98.2g.

Patina: Very rough pale-green, with much encrustation present. Details obliterated.

Manufacture: Nothing can be seen.

Use: Impossible to determine.

Reduction: The wings are broken, and their vestigial remains are very battered in appearance. Mistreatment - presumably as a result of hammering - is likely to have caused this damage, though no conclusive evidence of this can be seen.

12/20 (Acc. No. 94: 8-3: 25)

Description: Blade and lower body fragment of winged axe, minus blade edge and butt/upper body section.

Dimensions: Length (maximum): 58mm. Weight: 216.7g.

Patina: Rough grey-green, details obscured.

Manufacture: The casting seams have been completely removed. No other evidence can be identified.

Use: Impossible to determine.

Reduction: The object has been broken up, but no visible traces relating to this process can be seen.

12/21 (Acc. No. 94: 8-3: 10)

Description: Blade from winged axe or adze, with possible indications of a hollowsection evident at the break. There are no indications of the depression so characteristic of winged axes where blade and body join.

Dimensions: Length (maximum): 70mm. Weight: 119.2g.

Patina: Rough pale-brown, with some greenish patches near the cutting edge. Details obscured.

Manufacture: No traces of any casting seams remain. The cutting edge seems very narrow, with little indication of expansion.

Use: The edge is blunt, but does not appear to be particularly worn in appearance.

Reduction: Though the object has been fragmented, no traces of this process can be seen.

12/22 (Acc. No. 94: 8-3: 26)

Description: Hilt fragment of sword, with one intact rivet hole and another fragmentary example apparent.

Dimensions: Length (maximum): 60mm. Weight: 33.2g.

Patina: Dense grey-green, details reasonable.

Manufacture: All seams have been removed, and the piece appears very well-finished. There are some indications of hammering visible in the centre of the tang, but these may relate to fragmentation. There are also coarse striations visible near the intact rivet hole.

Use: Impossible to determine.

Reduction: The profile is distorted, possibly through hammering. The hammer marks noted are visible at the maximum point of this distortion, which may suggest that they are linked with this.

12/23 (Acc. No. 94: 8-3: 23)

Description: Fragment of blade from leaf-shaped sword, probably of 'Ewart Park' type.

Dimensions: Length (maximum): 50mm. Weight: 31.5g.

Patina: Smooth, grey-green in colour, with some reddish-brown patches visible. There is a highly polished appearance to the piece, and there is some encrustation in places. Details are locally good.

Manufacture: A faint bevel is visible in places on both cutting edges, and there are some indications of vertical grinding marks.

Use: One edge remains reasonably intact, though the other appears badly notched. This damage may appear exaggerated following the build-up of corrosion products.

Reduction: There are no indications of deliberate hammering, although slight distortion of the blade profile is apparent.

12/24 (Acc. No. 94: 8-3: 19)

Description: Socketed spearhead, with leaf-shaped blade.

Dimensions: Length (maximum): 98mm. Weight: 45.2g.

Patina: Dense grey-green, with some encrustation. Details locally good.

Manufacture: No traces of any casting seams remain. Grinding marks are visible, running along the interface between the midrib and the blade.

Use: The edges seem badly notched and blunt on both sides.

Reduction: A jagged break runs around the base of the socket, and both rivet holes are absent. This could be use-related damage, as the the section shows no signs of distortion and there are no associated hammer marks.

12/25 (Acc. No. 94: 8-3: 20)

Description: Socket and base of blade from socketed spearhead. The socket is decorated around the base by three groups of four concentric grooves which encircle the socket. There is one rivet hole present.

Dimensions: Length (maximum): 54mm. Weight: 29.7g.

Patina: Rough light-green, with much encrustation. Details poor.

Manufacture: The wall appears markedly thinner on one side of the midrib, suggesting core misalignment. The casting seams have been removed.

Use: The edge, where it remains, seems blunt and rather rough in appearance.

Reduction: One side of the blade, near the break, has been hammered inwards, and the section is distorted here.

12/26 (Acc. No. 94: 8-3: 20)

Description: Hilt and upper blade of 'Thorndon' type socketed knife.

Dimensions: Length (maximum): 82mm. Weight: 45.5g.

Patina: Thick grey-green, with some encrustation in places. Details poor.

Manufacture: Some small hammer marks are apparent at the interface between the socket and the blade. The casting seams have been obliterated.

Use: The cutting edges are now completely absent. There are notches, and some more substantial chunks, missing down the length of the blade, though some additional damage appears more recent in date.

Reduction: Some possible hammer marks are visible inside the socket, and the section shows slight outward distortion here, with the mouth of the socket appearing rough and broken. The blade profile is straight and undistorted, but at the break the bronze shows surface cracking and looks strained, possibly as a result of the piece having been snapped into large pieces.

12/27 (Believed to be 94: 8-3: 22 - the piece was found stored in an Unprovenanced drawer in 1992, but comparison with illustrations suggested that it belonged to this hoard)

Description: Socketed gouge, with a large portion missing from the rear of the object.

Dimensions: Length (maximum): 83mm. Weight: 43.0g.

Patina: Corrosion stripped, but there are some details surviving.

Manufacture: No traces of any casting seams survive anywhere on the piece. Some vertical grinding marks are visible on the interior of the blade.

Use: Impossible to determine.

Reduction: There are no visible indications of hammering near the break. The mouth seems rather rough, and the socket has been crushed inwards.

12/28 (Acc. No. 94: 8-3: 24)

Description: Fragment of plain, undecorated sickle blade, with tip and butt now missing.

Dimensions: Length (maximum): 67mm. Weight: 35.7g.

Patina: Rough mid-green/dark green. Details obscured.

Manufacture: No traces of any casting seams remain visible, and no other evidence - e.g. grinding marks - can be identified.

Use: The original edge has gone. Some of this damage may result from later loss of the corrosion product, but it seems likely that the edge was originally in poor condition.

Reduction: No indications. The profile seems straight with no signs of distortion.

12/29 (Acc. No. 94: 8-3: 28)

Description: Large portion of copper cake.

Dimensions: Length: 95mm. Width: 67mm. Thickness: 33mm. Weight: 775.7g.
Observations: Deep grooves run across the surface, suggesting some kind of alternative use as a cutting or a striking platform. However, with the corrosion stripped, it is impossible to determine unequivocally whether or not these scores were inflicted in antiquity (c.f. 12/29). There are also indications of small chisel marks on the piece, similar to those seen on other ingot fragments.

12/30 (Acc. No. 94: 8-3: 28)

Description: Piece from edge of copper ingot.

Dimensions: Length: 63mm. Width: 50mm. Thickness: 22mm. Weight: 356.9g.

12/31 (Acc. No. 94: 8-3: 28)

Description: Piece from edge of copper ingot, very thick in section.

Dimensions: Length: 85mm. Width: 55mm. Thickness: 33mm. Weight: 659.7g.

Observations: There are some possible small tool marks on underside.

12/32 (Acc. No. 94: 8-3: 28)

Description: Large piece of copper ingot.

Dimensions: Length: 95mm. Width: 90mm. Thickness: 30mm. Weight: 987.9g.

Observations: Some striations are present on the surface, and the patinated nature of the metal and a covering of adhering soil indicates that this damage took place in antiquity (c.f. 12/29). There are also possible indications of small tool marks.

12/33 (Acc. No. 94: 8-3: 28)

Description: Piece from edge of copper ingot.

Dimensions: Length: 67mm. Width: 69mm. Thickness: 37mm.

12/34 (Acc. No. 94: 8-3: 28)

Description: Piece from edge of copper ingot.

Dimensions: Length: 69mm. Width: 38mm. Thickness: 40mm. Weight: 267.6g.

12/35 (Acc. No. 94: 8-3: 28)

Description: Interior fragment of copper ingot.

Dimensions: Length: 50mm. Width: 27mm. Thickness: 23mm. Weight: 183.4g.

12/36 (Acc. N. 94: 8-3: 28)

Description: Edge fragment of copper cake.

Dimensions: Thickness: 40mm. Weight: 148.1g.

12/37 (Acc. No. 94: 8-3: 28)

Description: Interior fragment of copper ingot, with voids visible in metal.

Dimensions: Length: 35mm. Width: 25mm. Thickness: 17mm. Weight: 84.0g.

Observations: There are possible small tool marks visible on the surface. It is impossible to gauge the likely date of this damage, because the corrosion has been stripped. but it seems quite likely that it took place in antiquity.

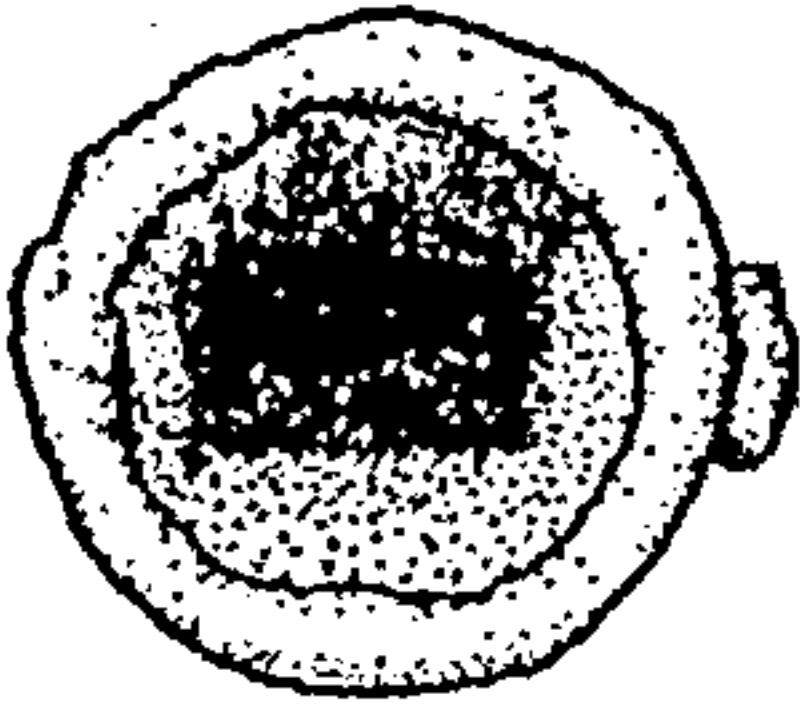
12/38 (Acc. No. 94: 8-3: 28)

Description: Edge fragment of copper ingot.

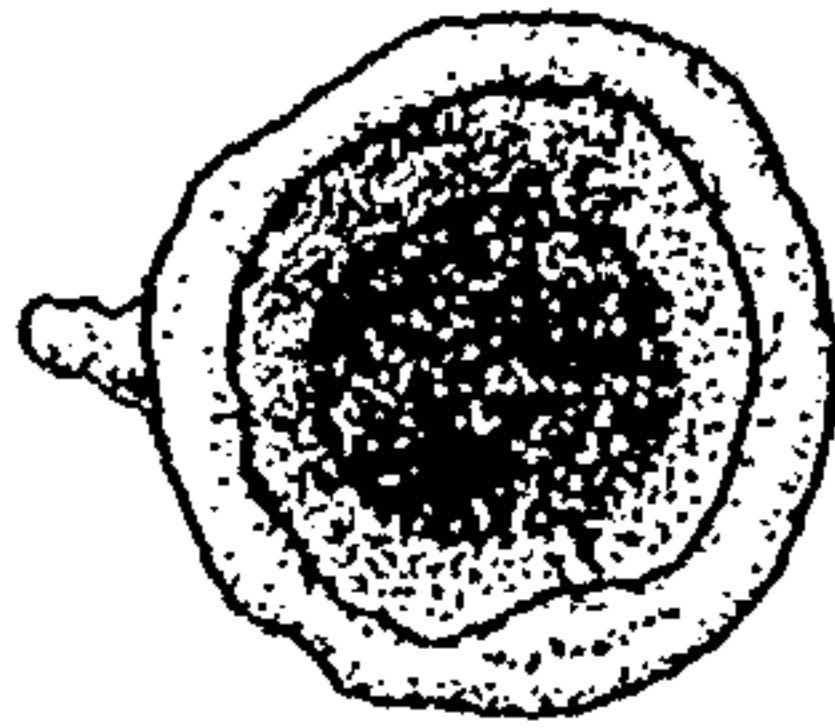
Dimensions: Length: 53mm. Width: 35mm. Thickness: 19mm. Weight: 156.9g.

Observations: Some small tool marks can be seen on the piece.

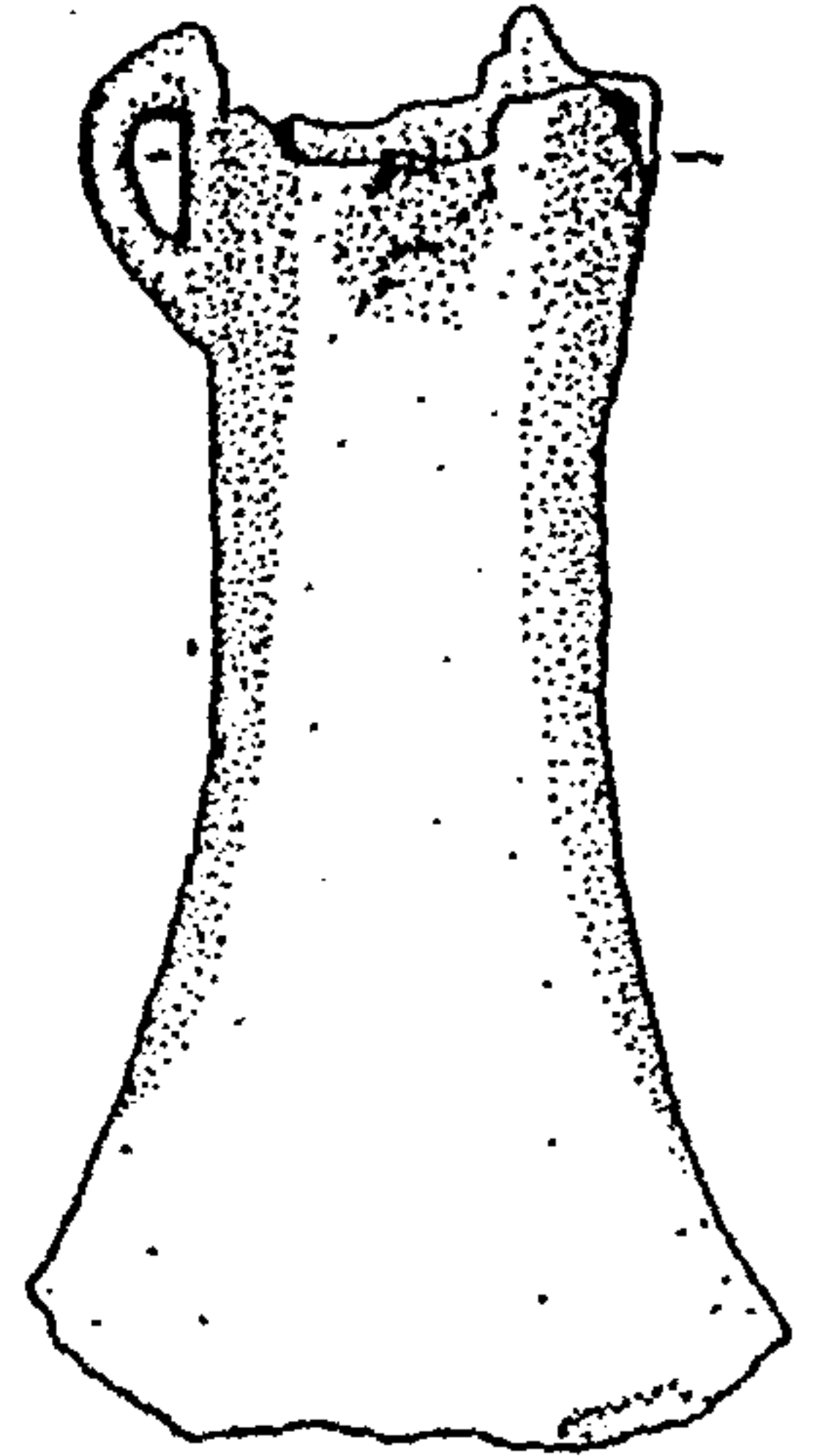
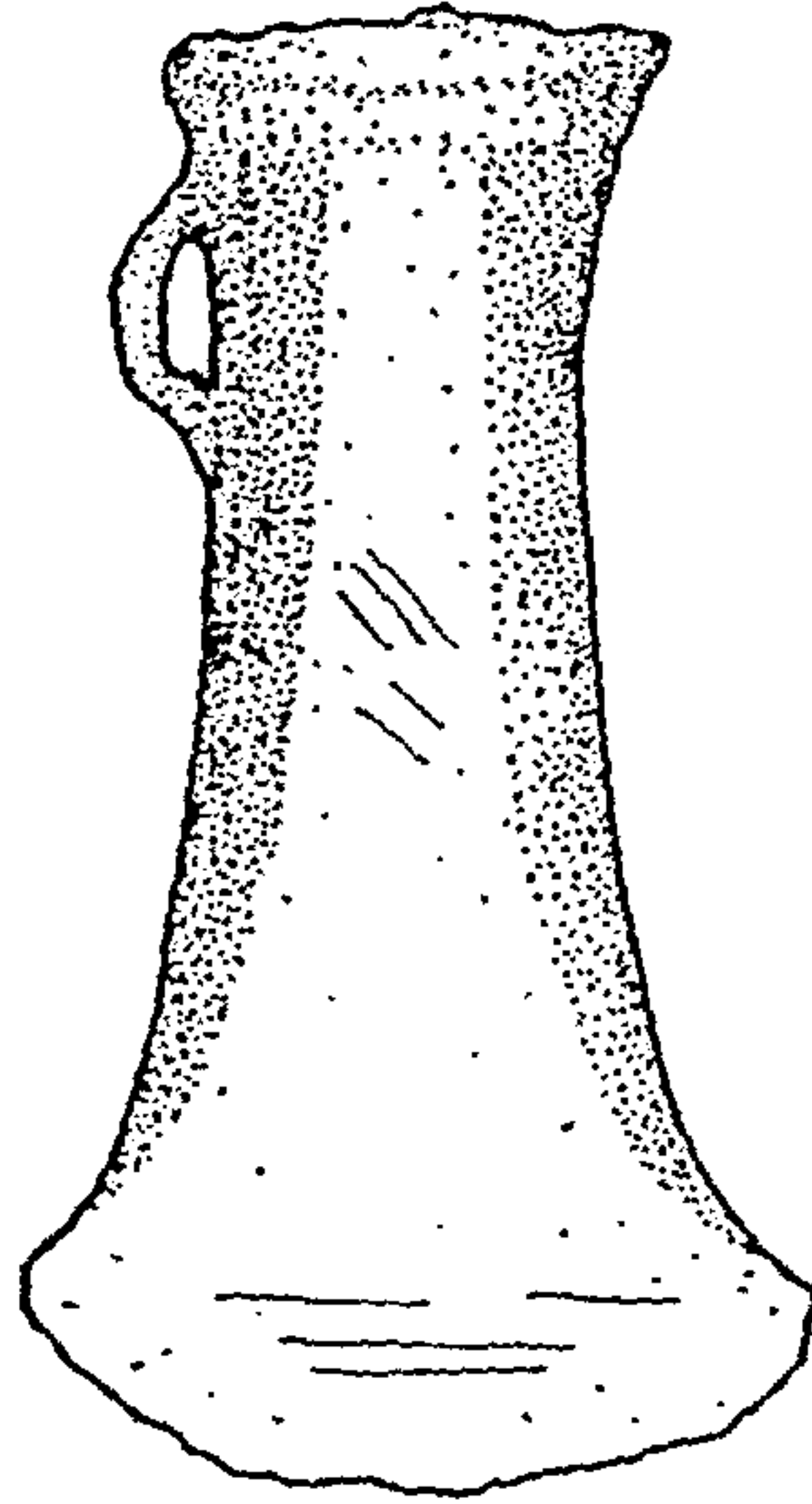
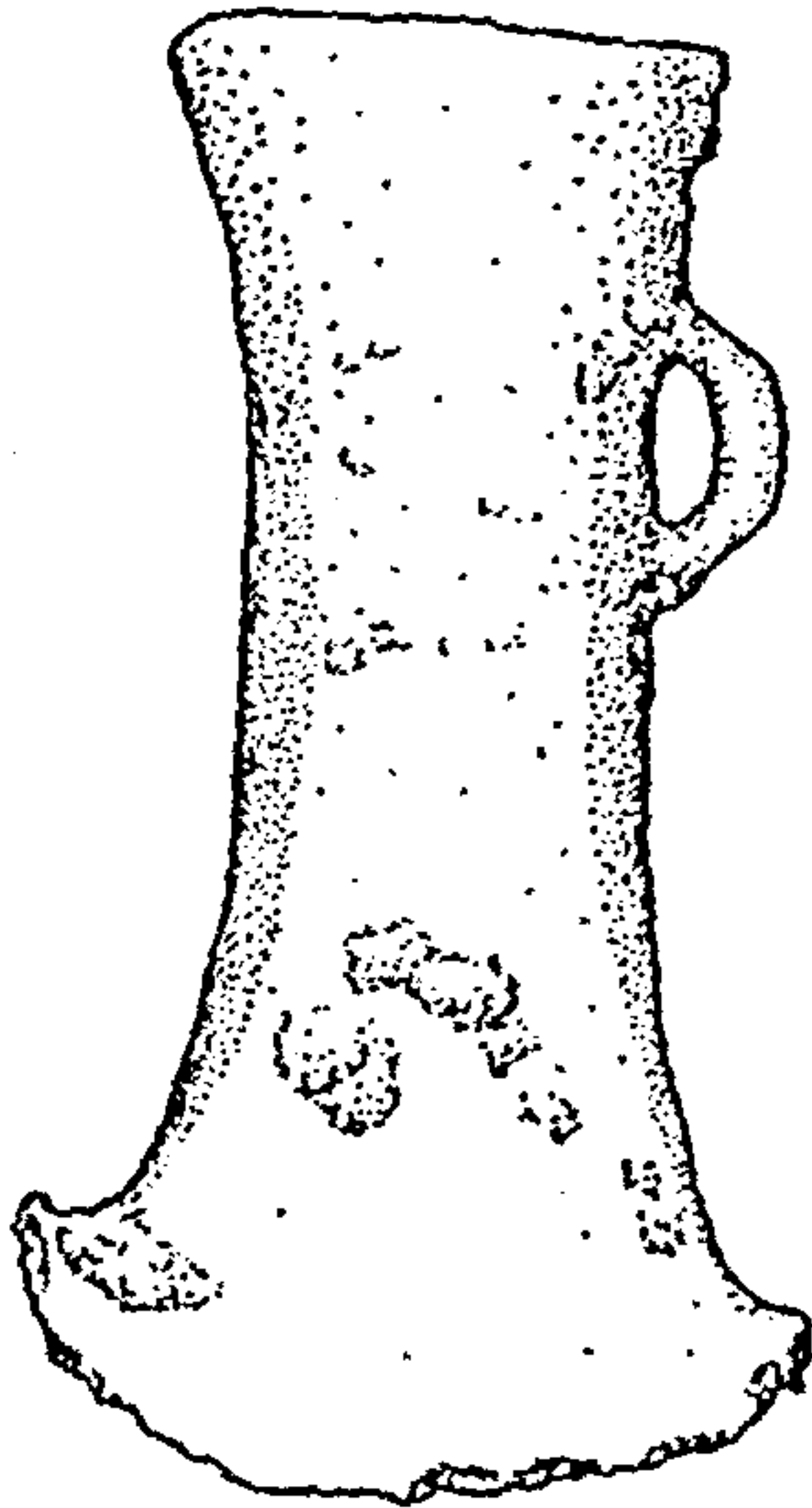
12/01



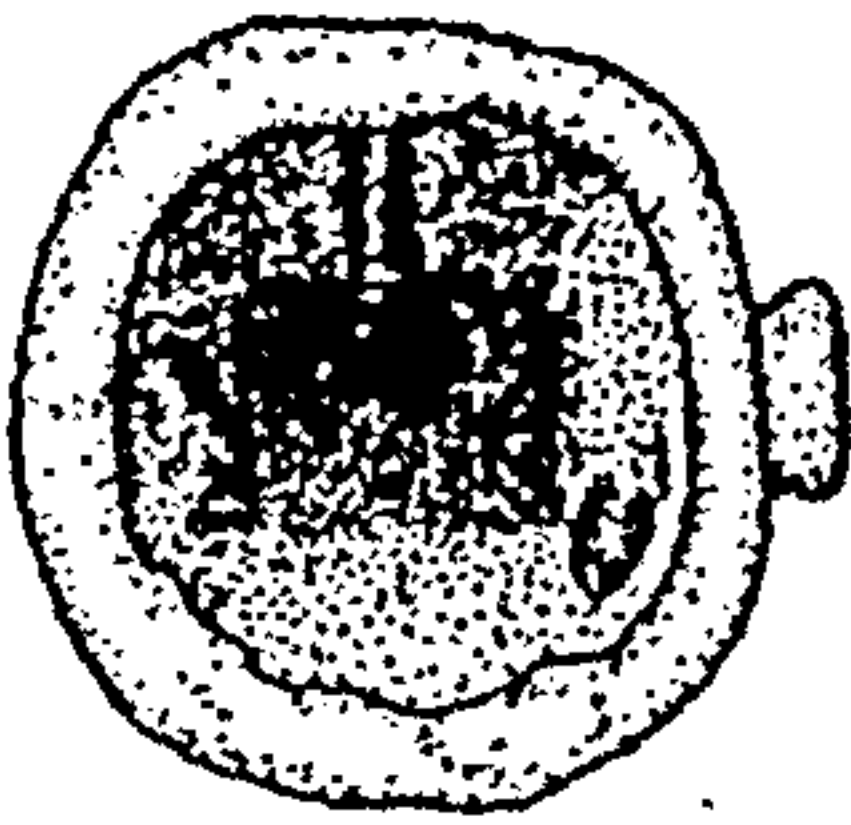
12/02



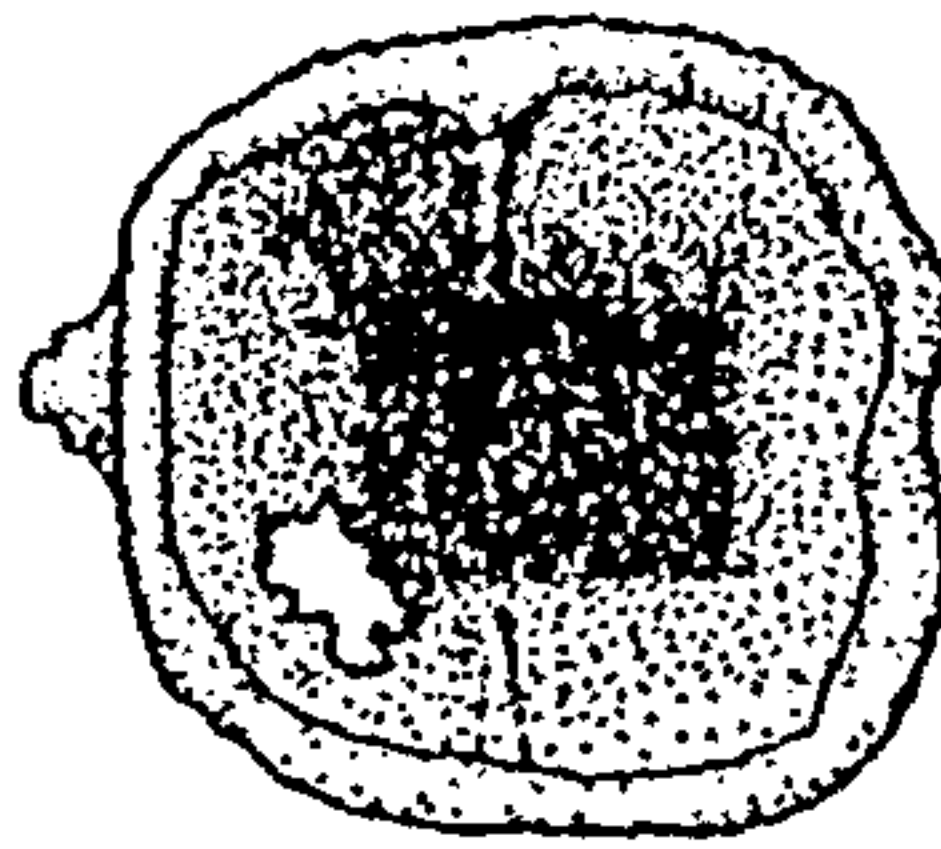
12/03



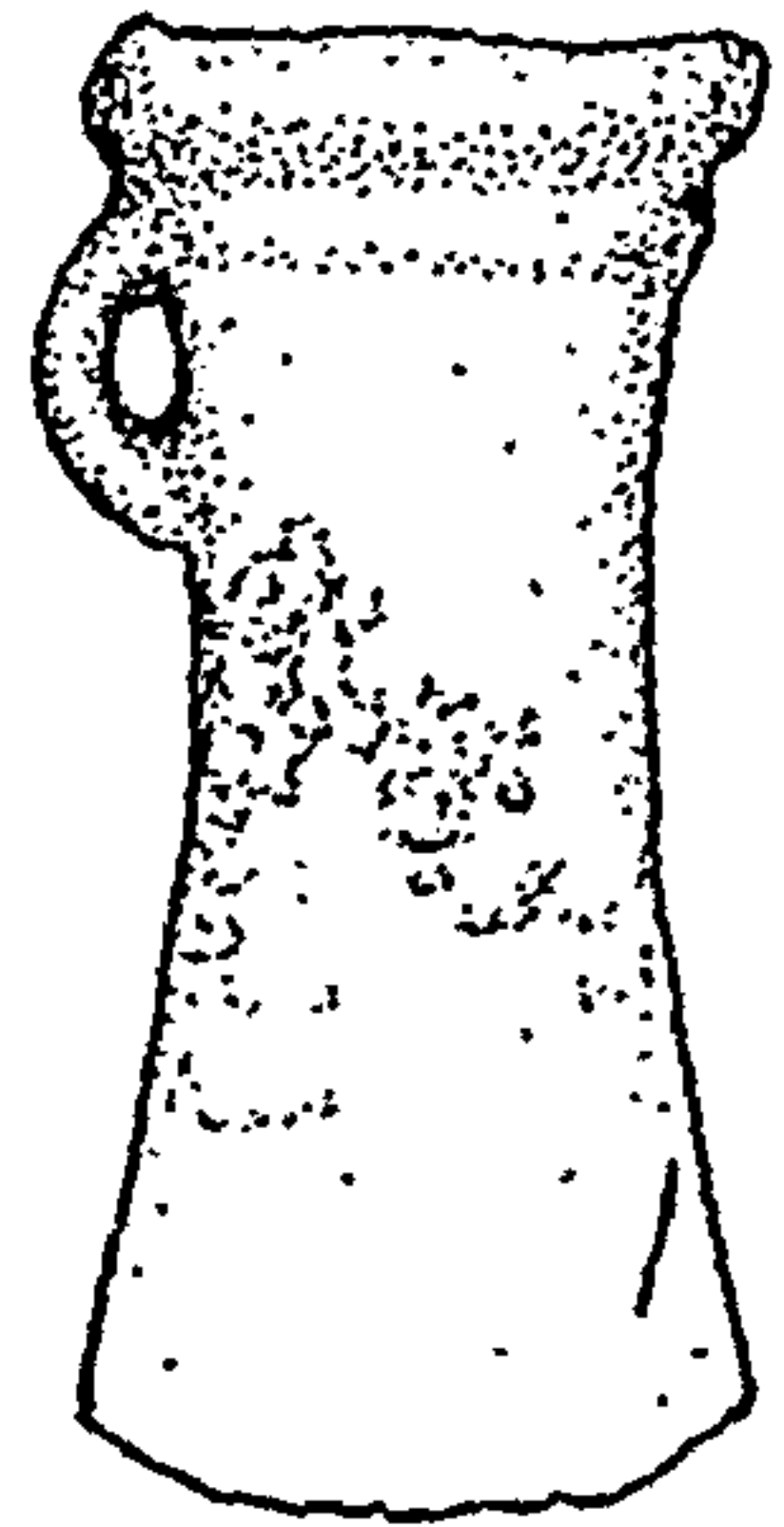
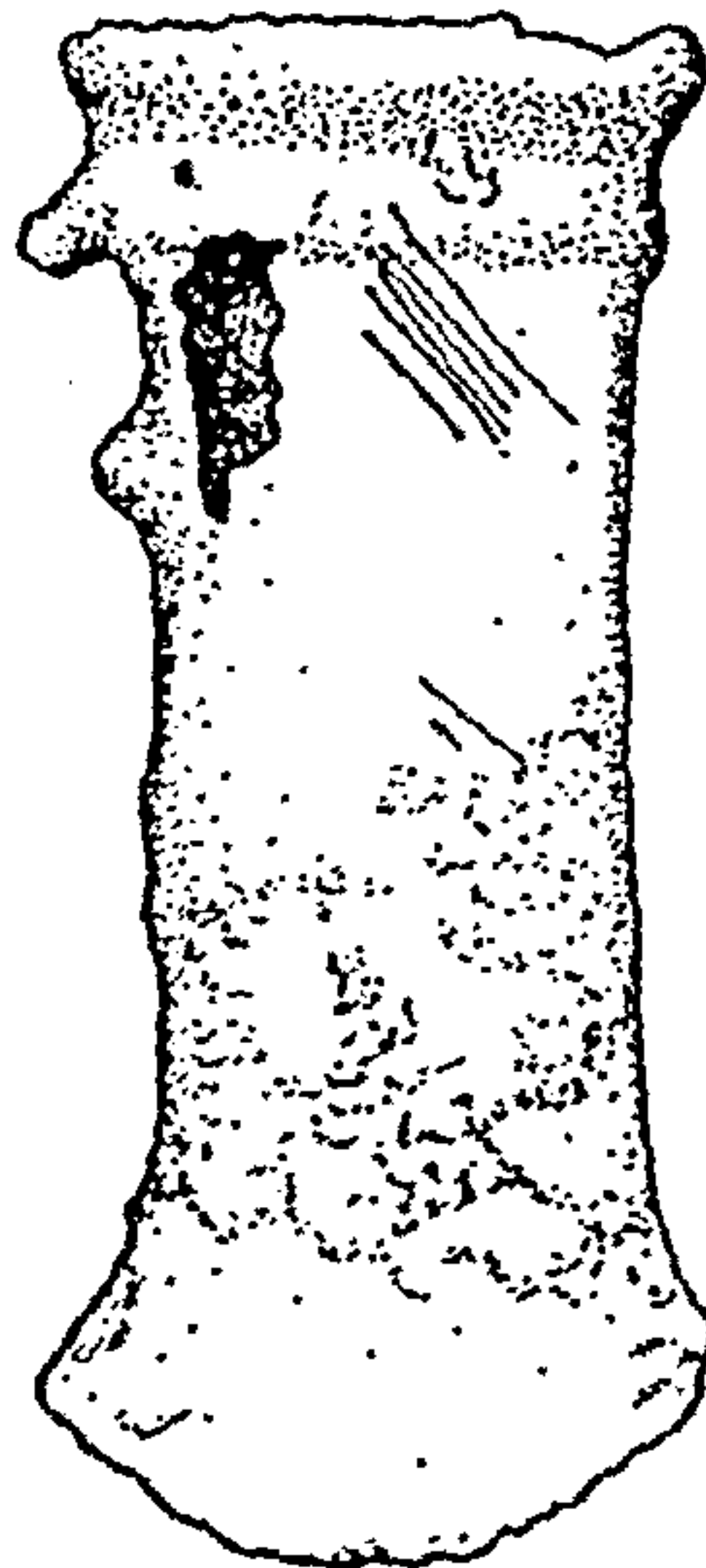
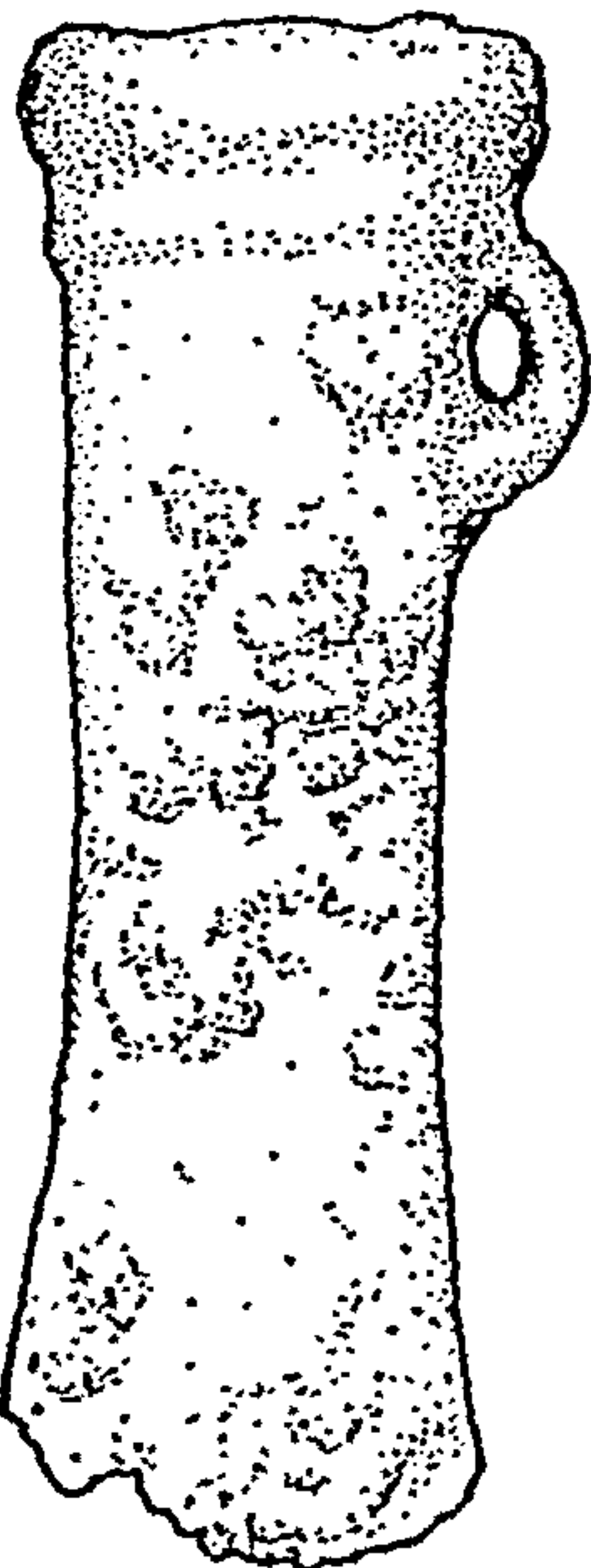
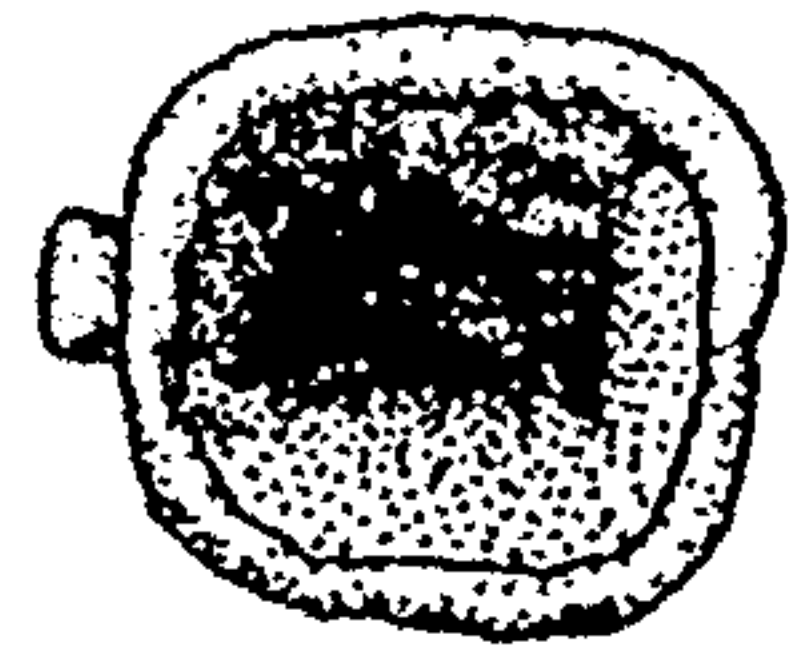
12/04



12/05



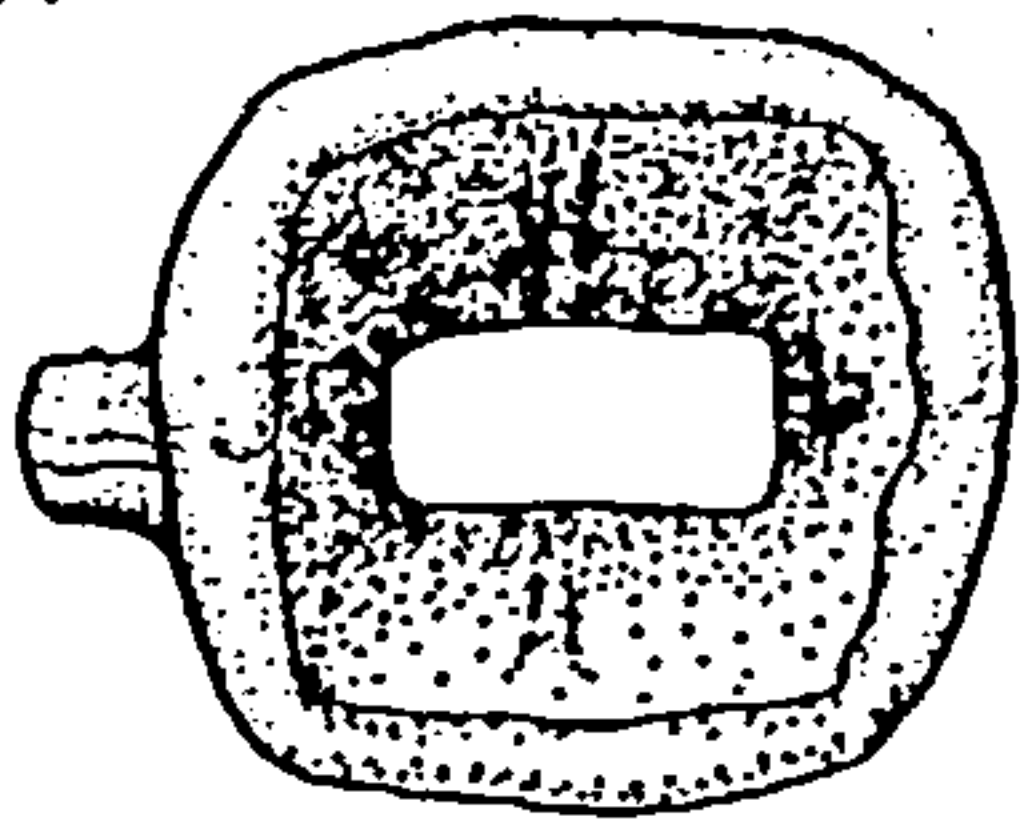
12/06



0 2cm

Fig. 1. The All Hallows I Hoard (Ref. No.12): Complete Socketed axes

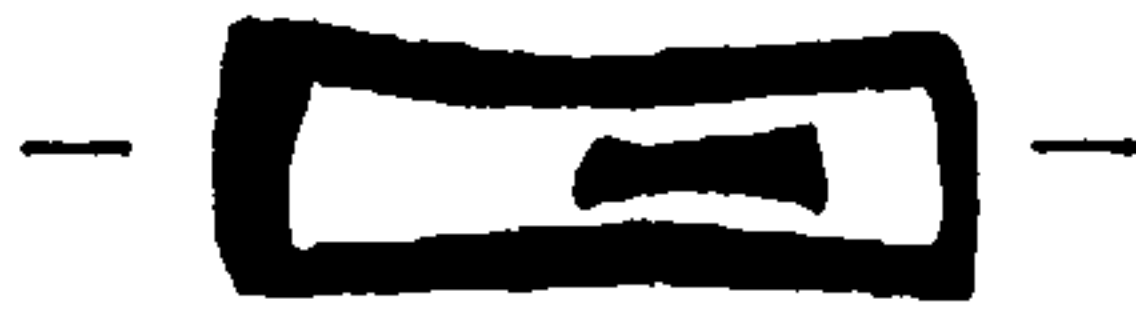
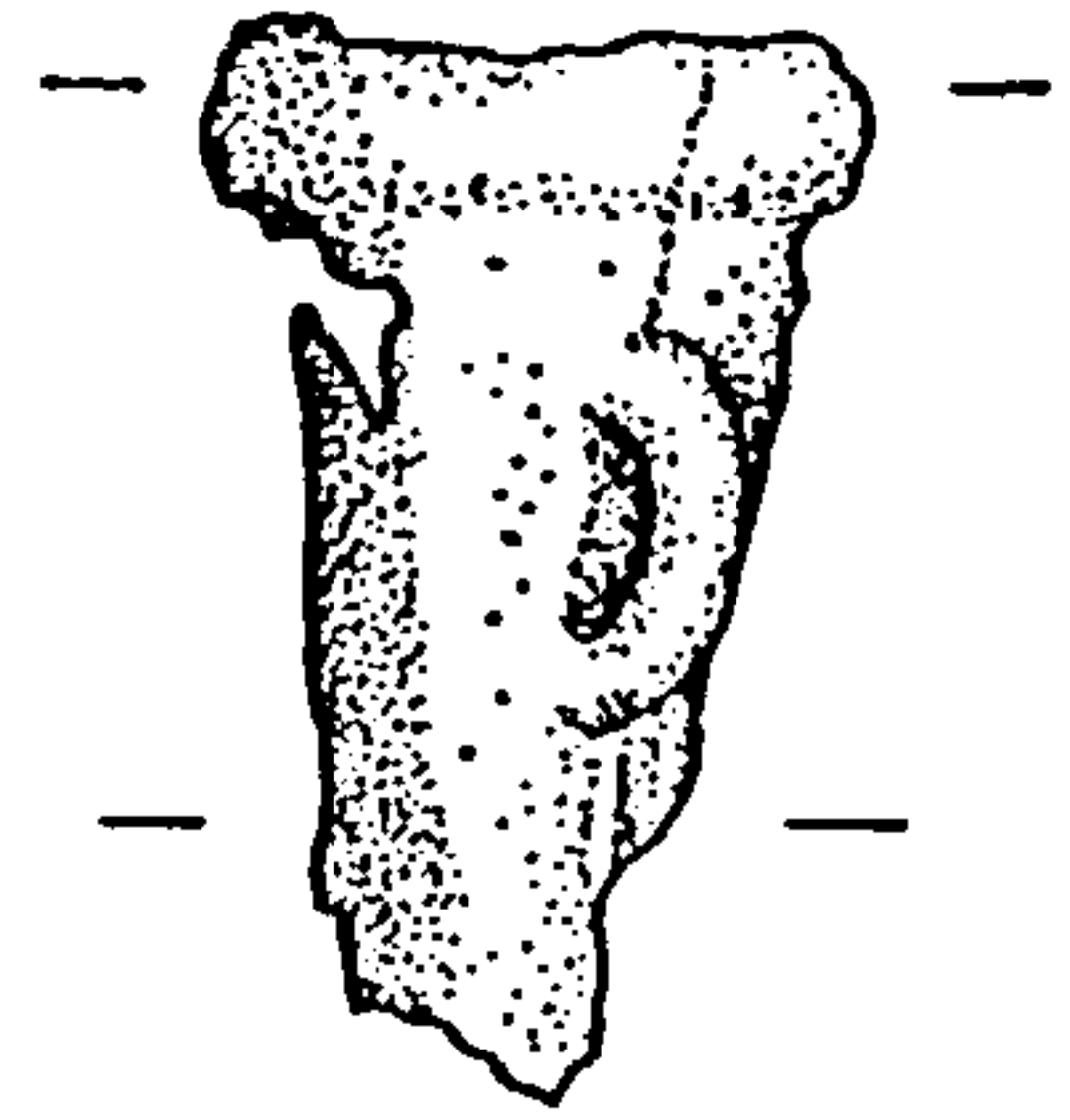
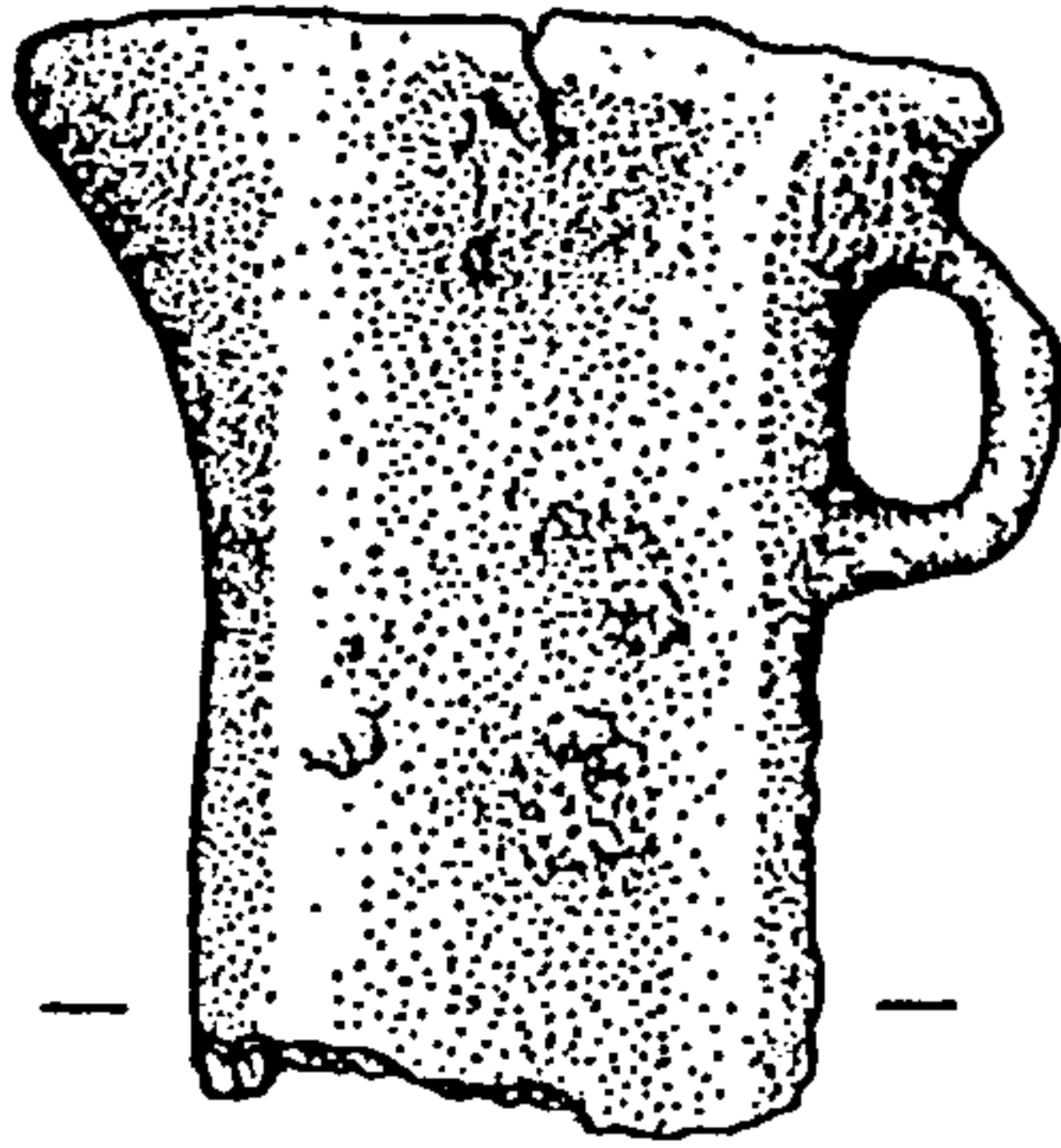
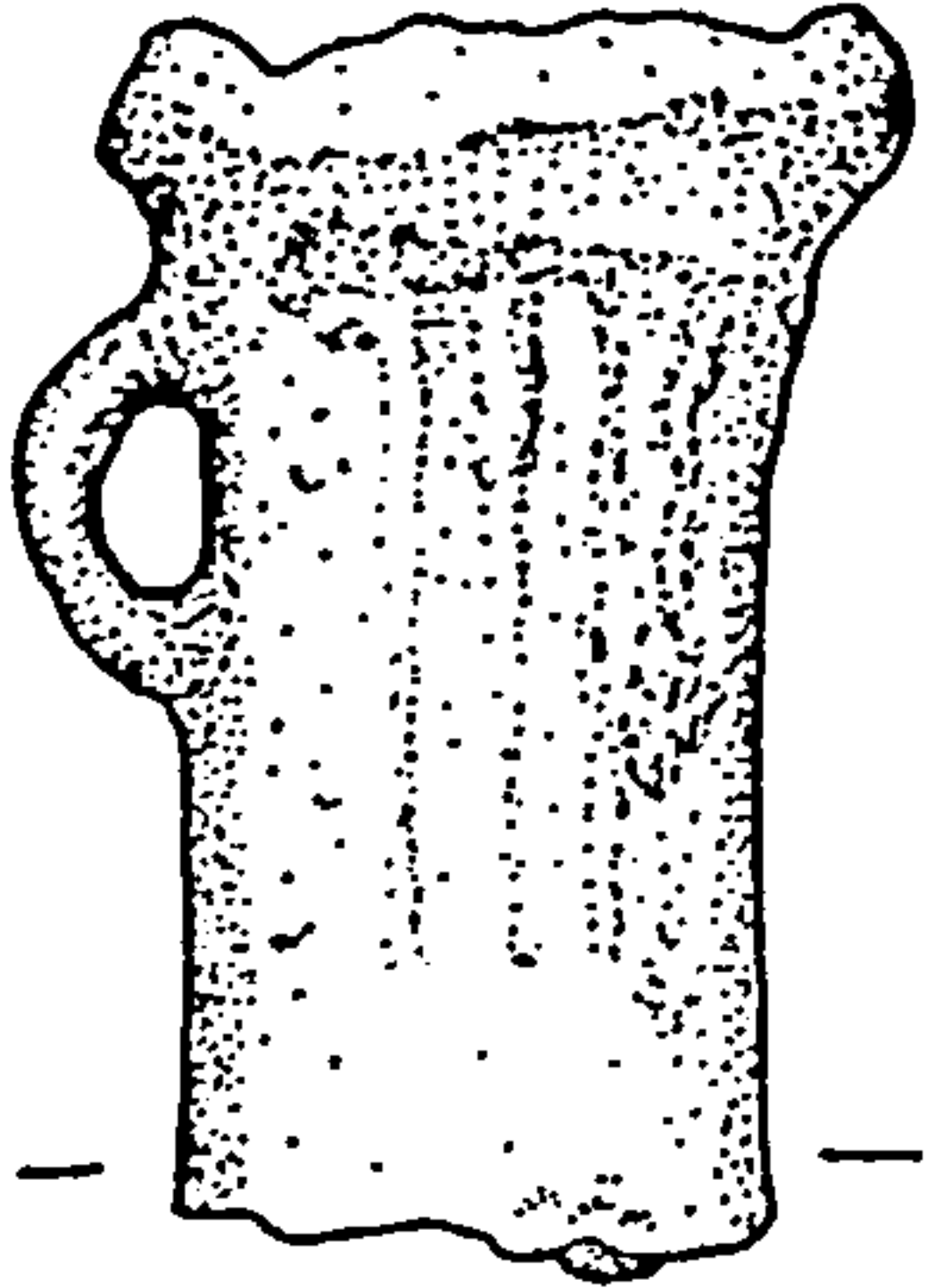
12/07



12/08



12/09



0 2cm

12/10



12/11

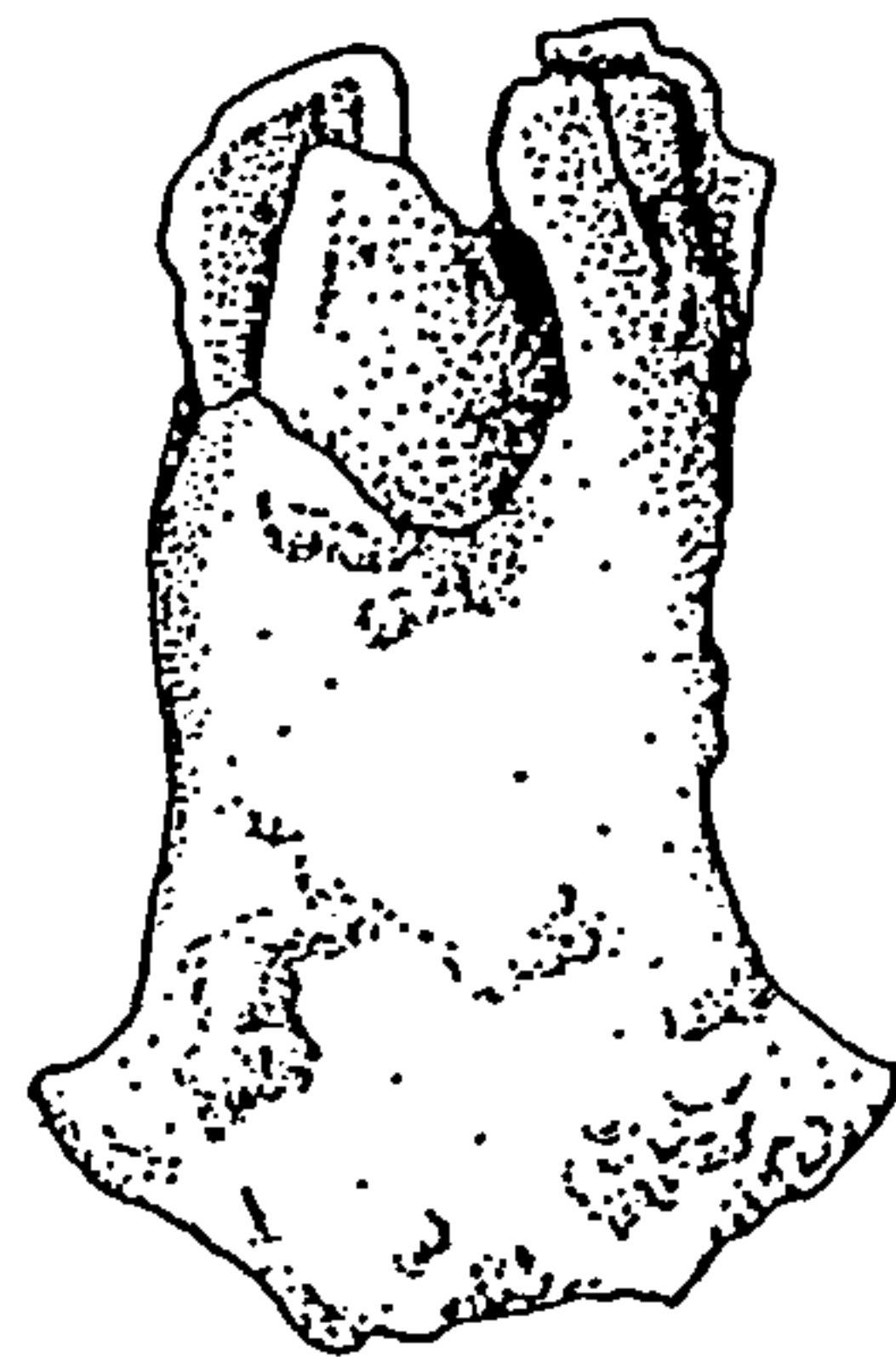
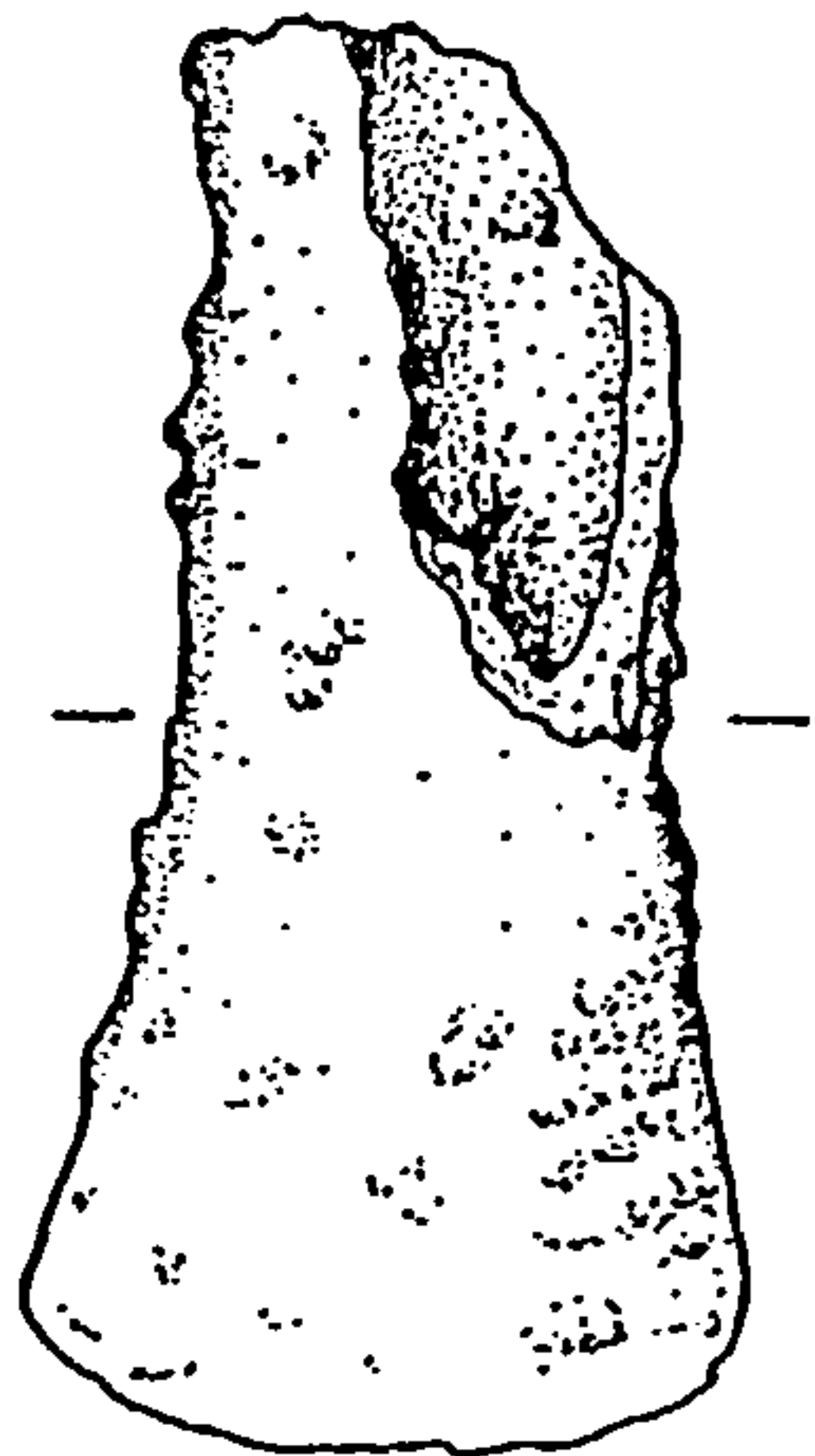
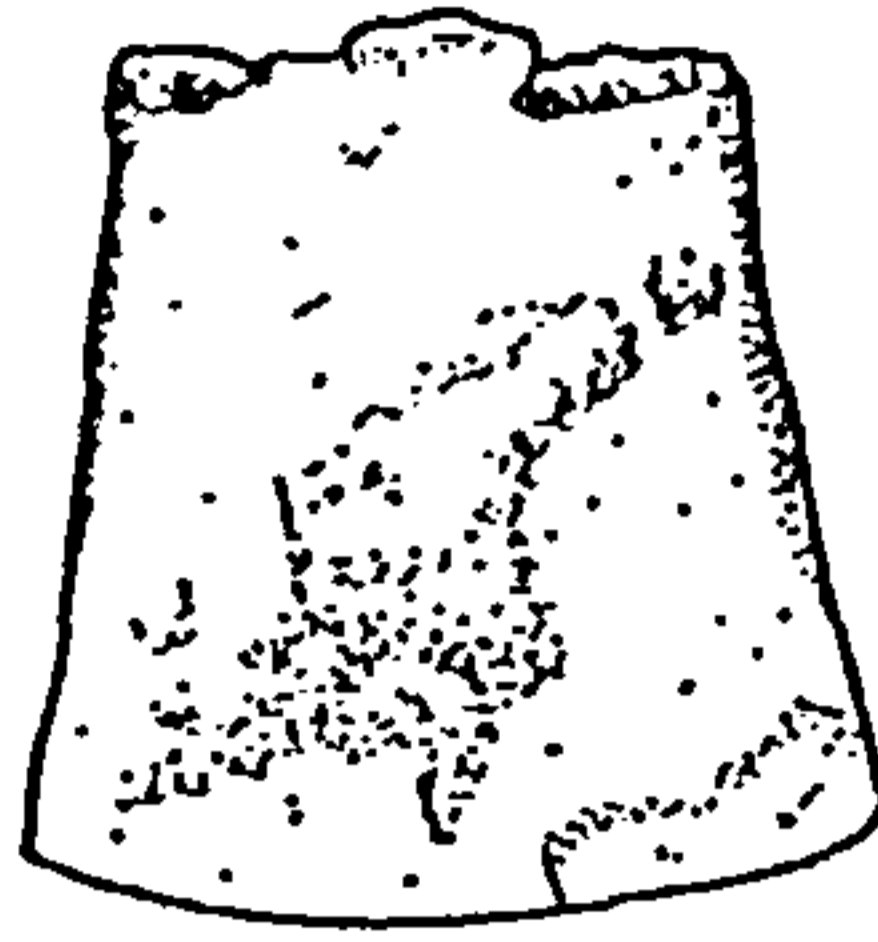
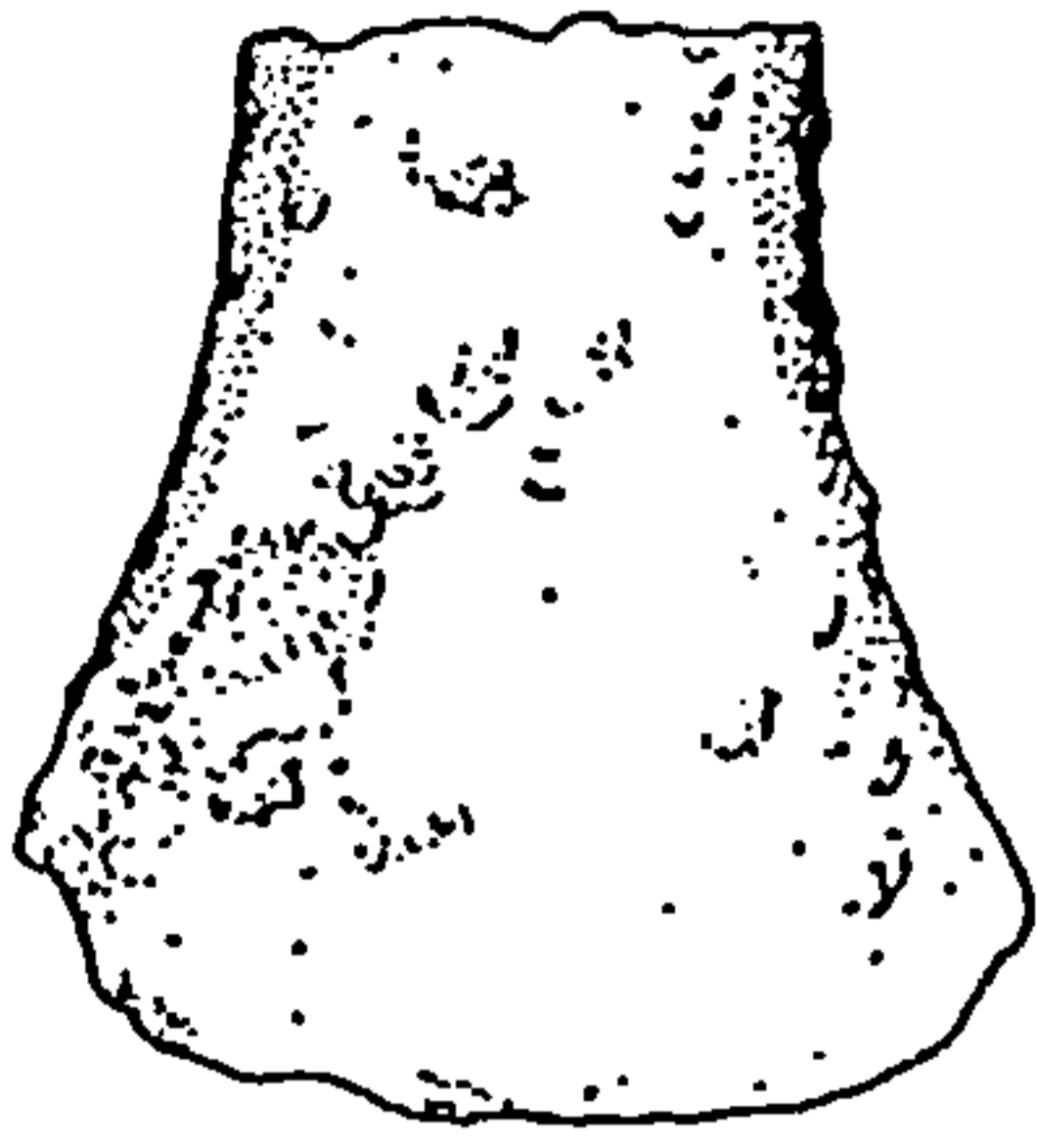


Fig. 2. The All Hallows I Hoard (Ref. No. 12): Socketed Axe Fragments (i)

12/12

12/13

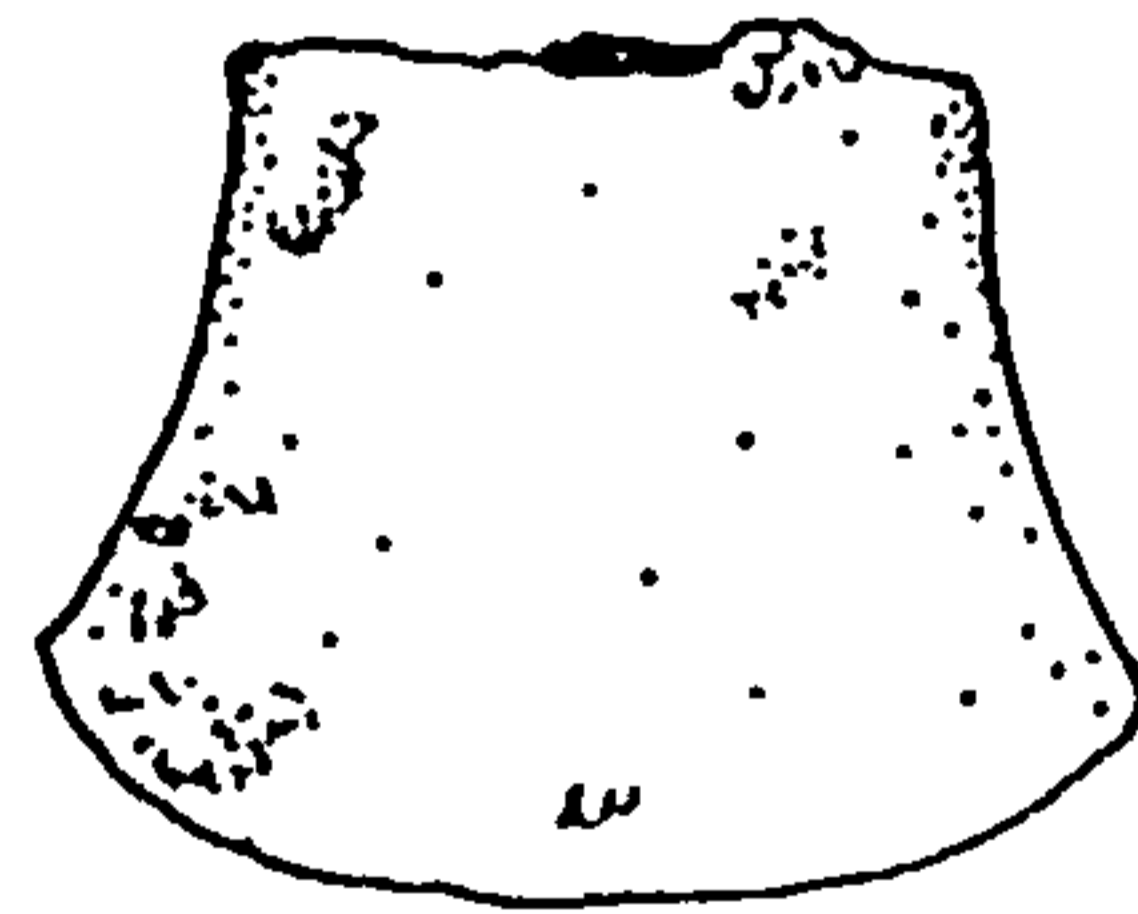
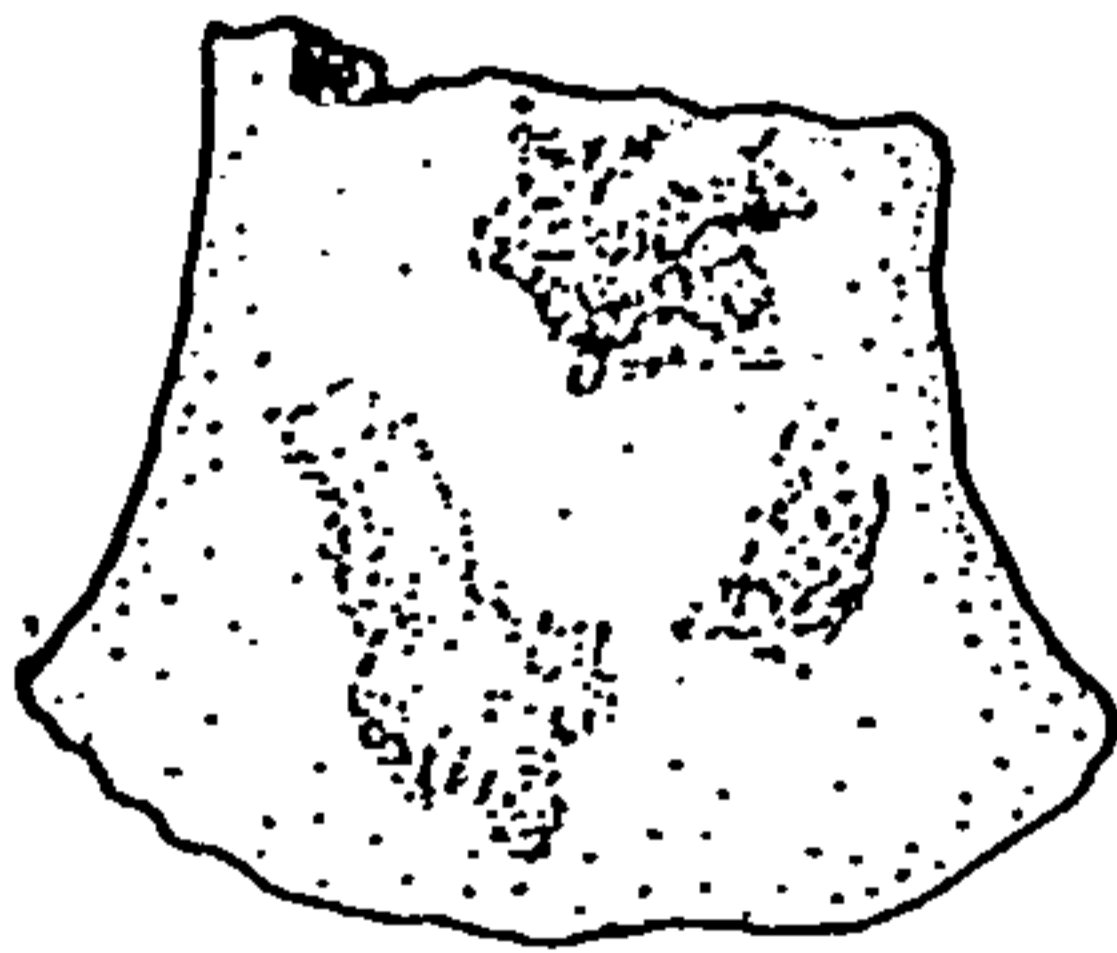
12/14



0 2cm

12/15

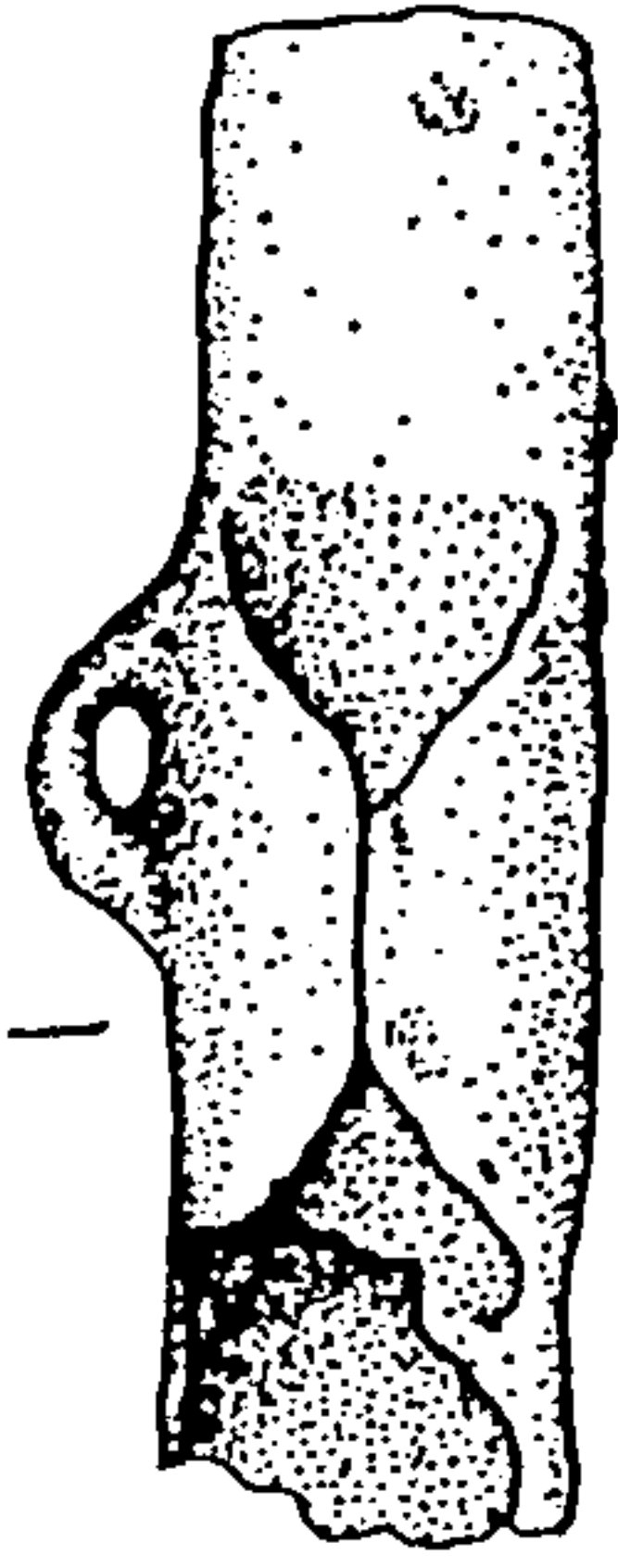
12/16



Rough Metal/Corrosion Product

Fig. 3. The All Hallows I Hoard (Ref. No. 12): Socketed Axe Fragments (ii)

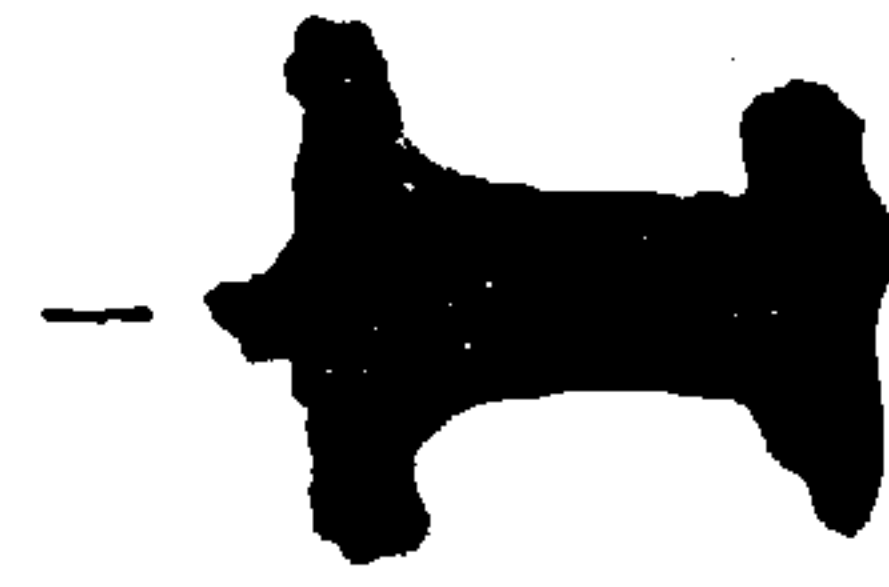
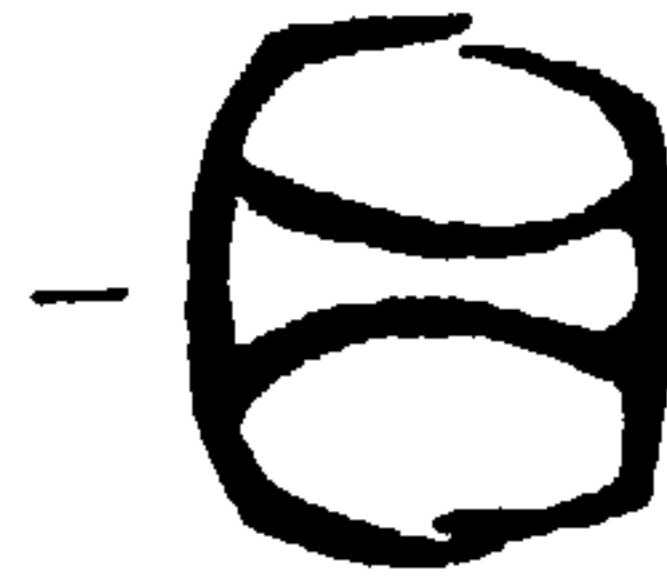
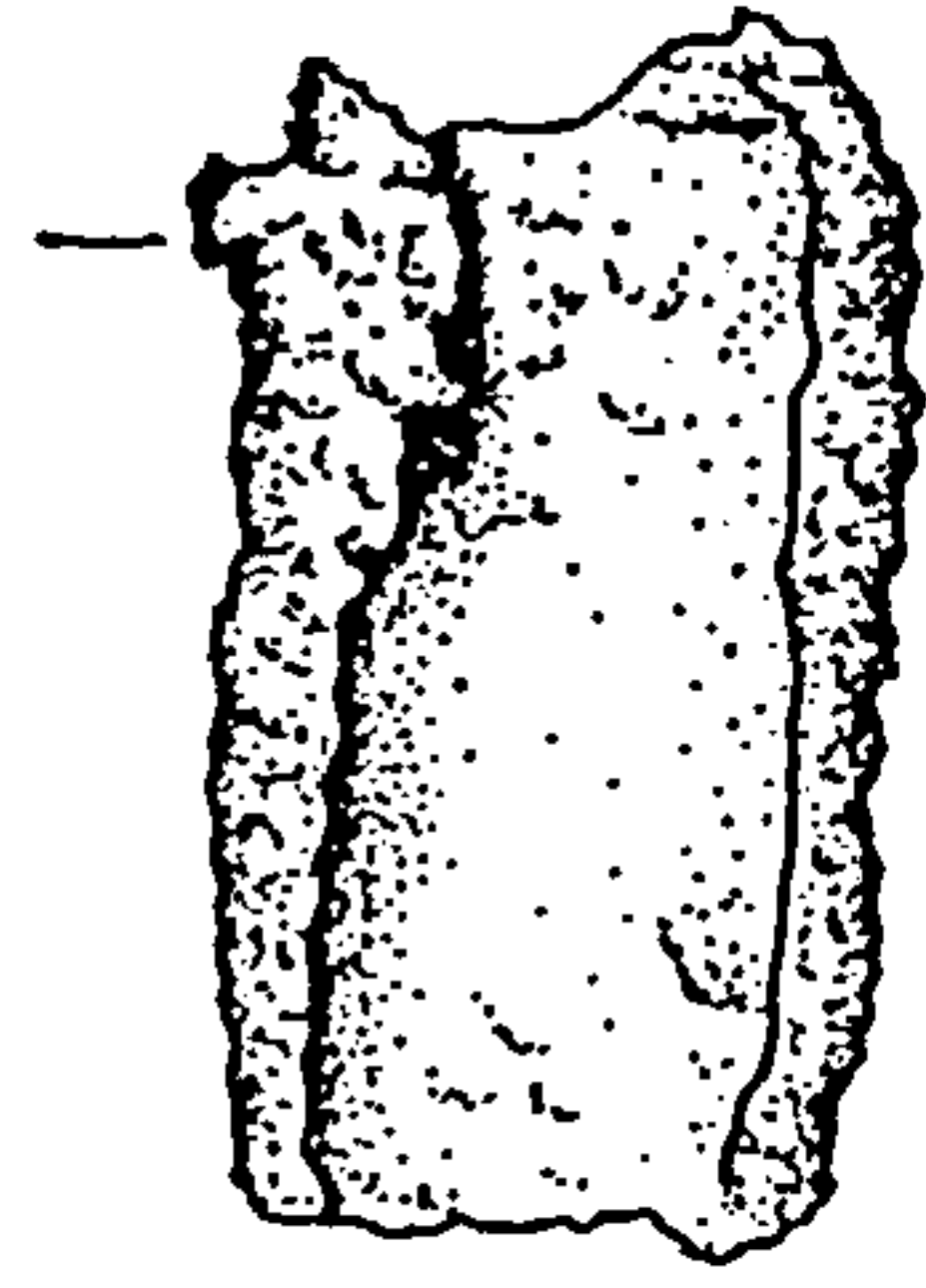
12/17



12/18

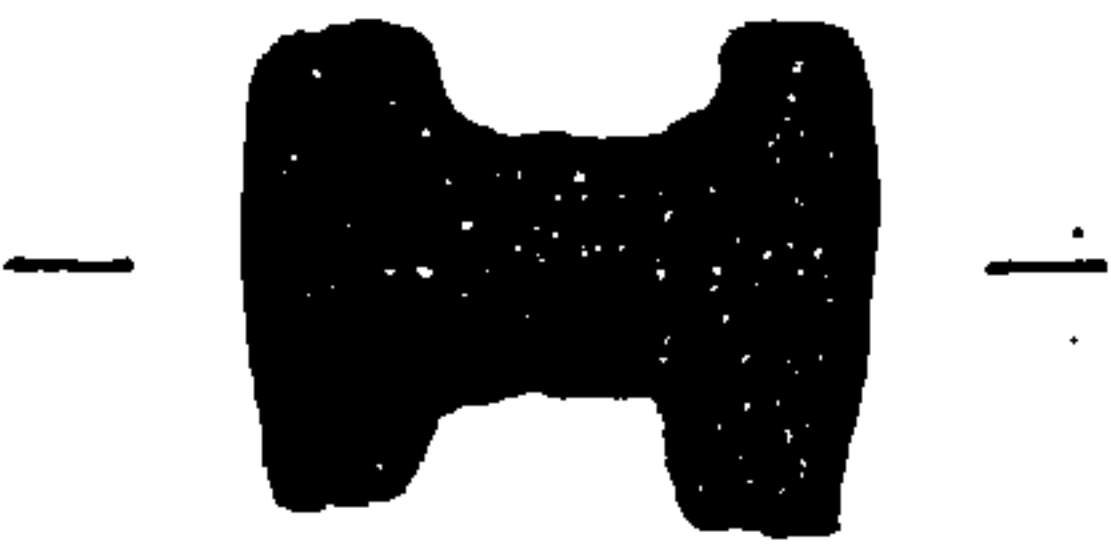


12/19



0 2cm

12/20



12/21

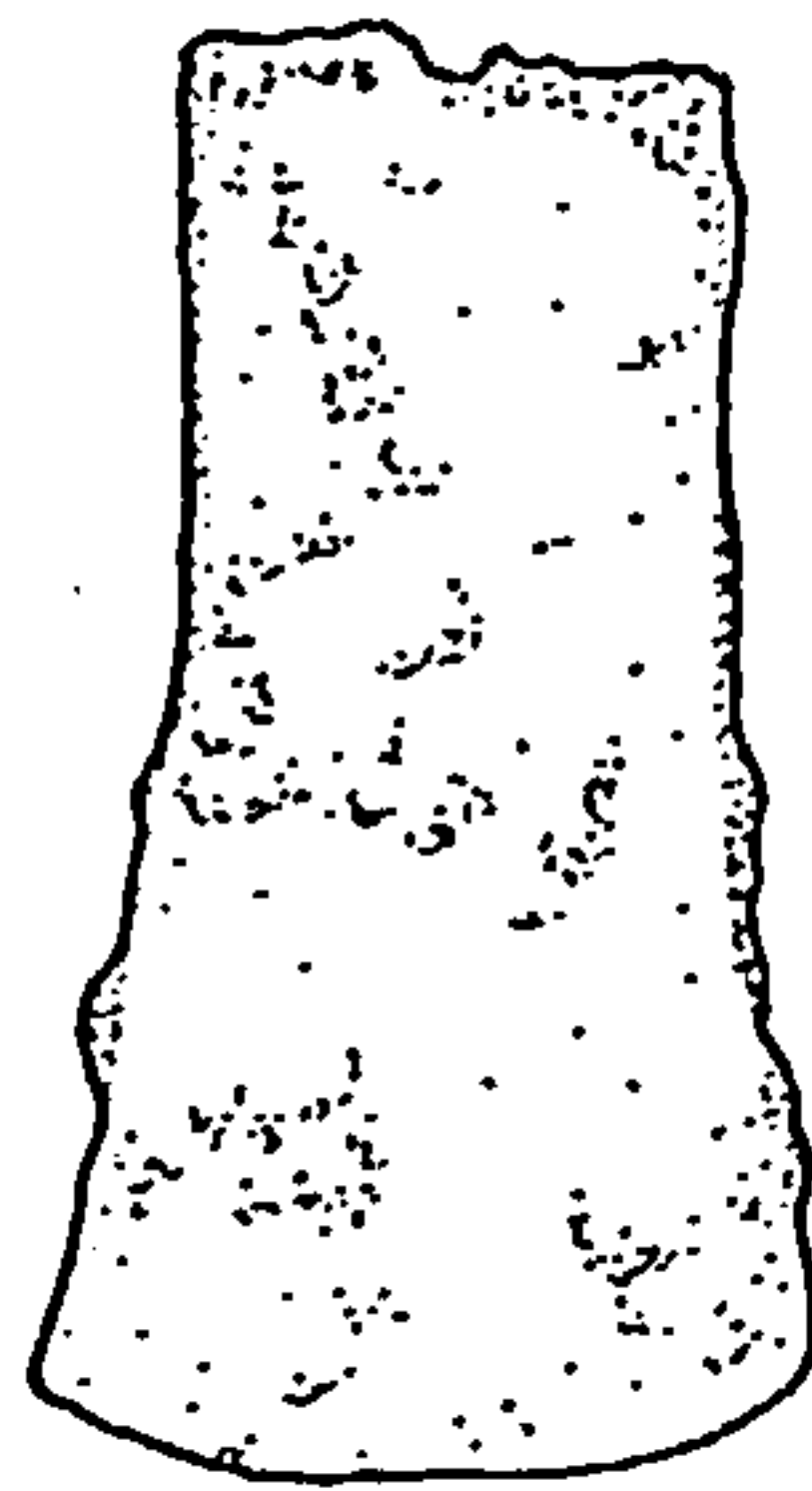
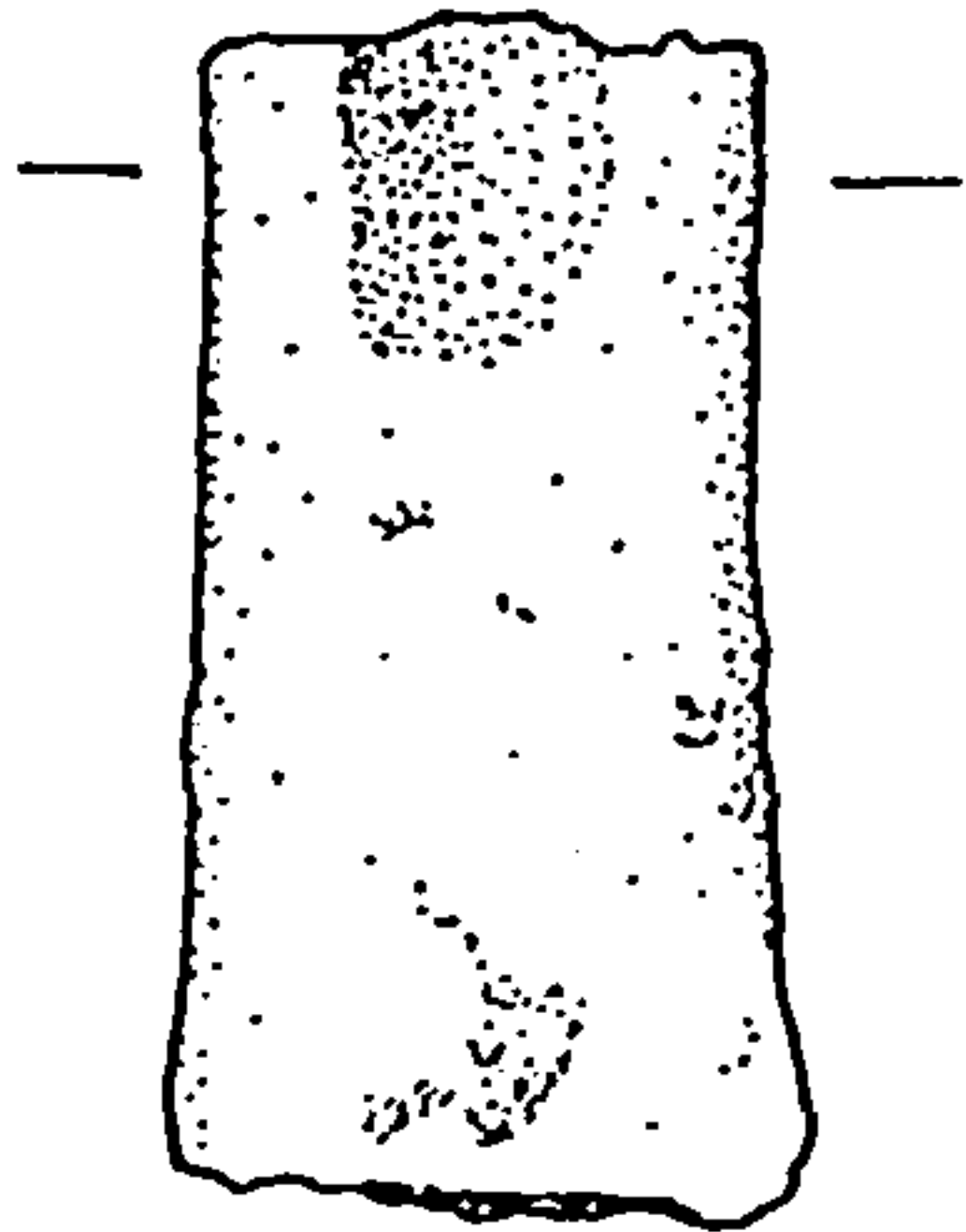


Fig. 4. The All Hallows I Hoard (Ref. No. 12): Winged Axes

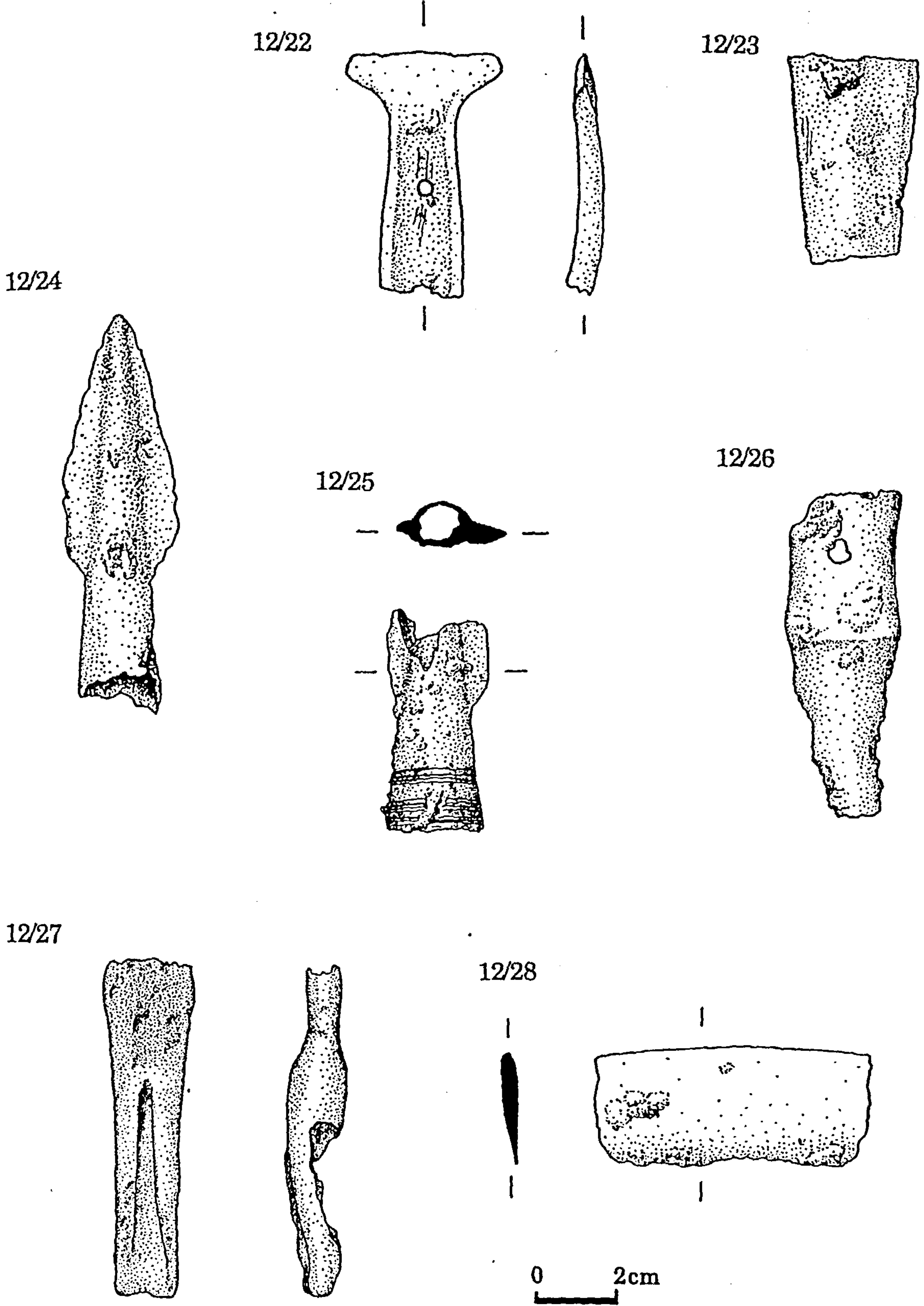
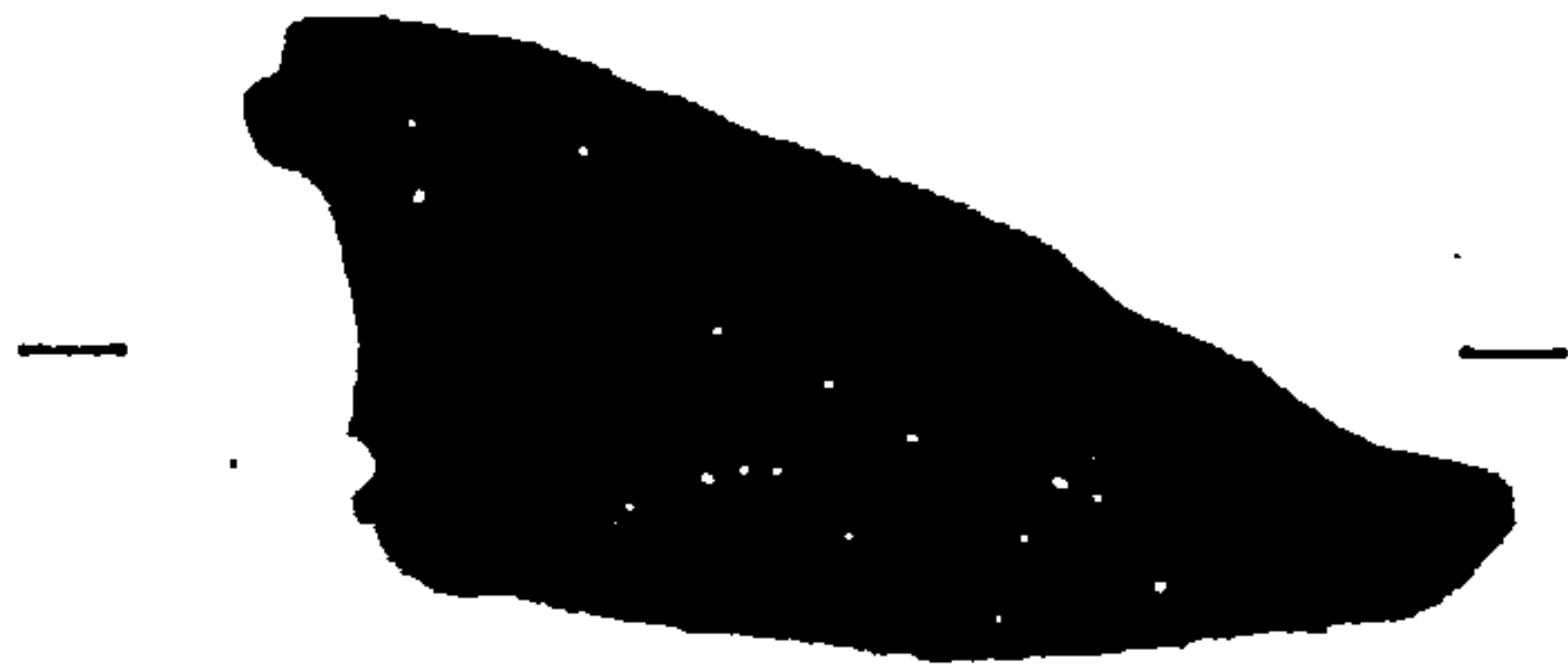
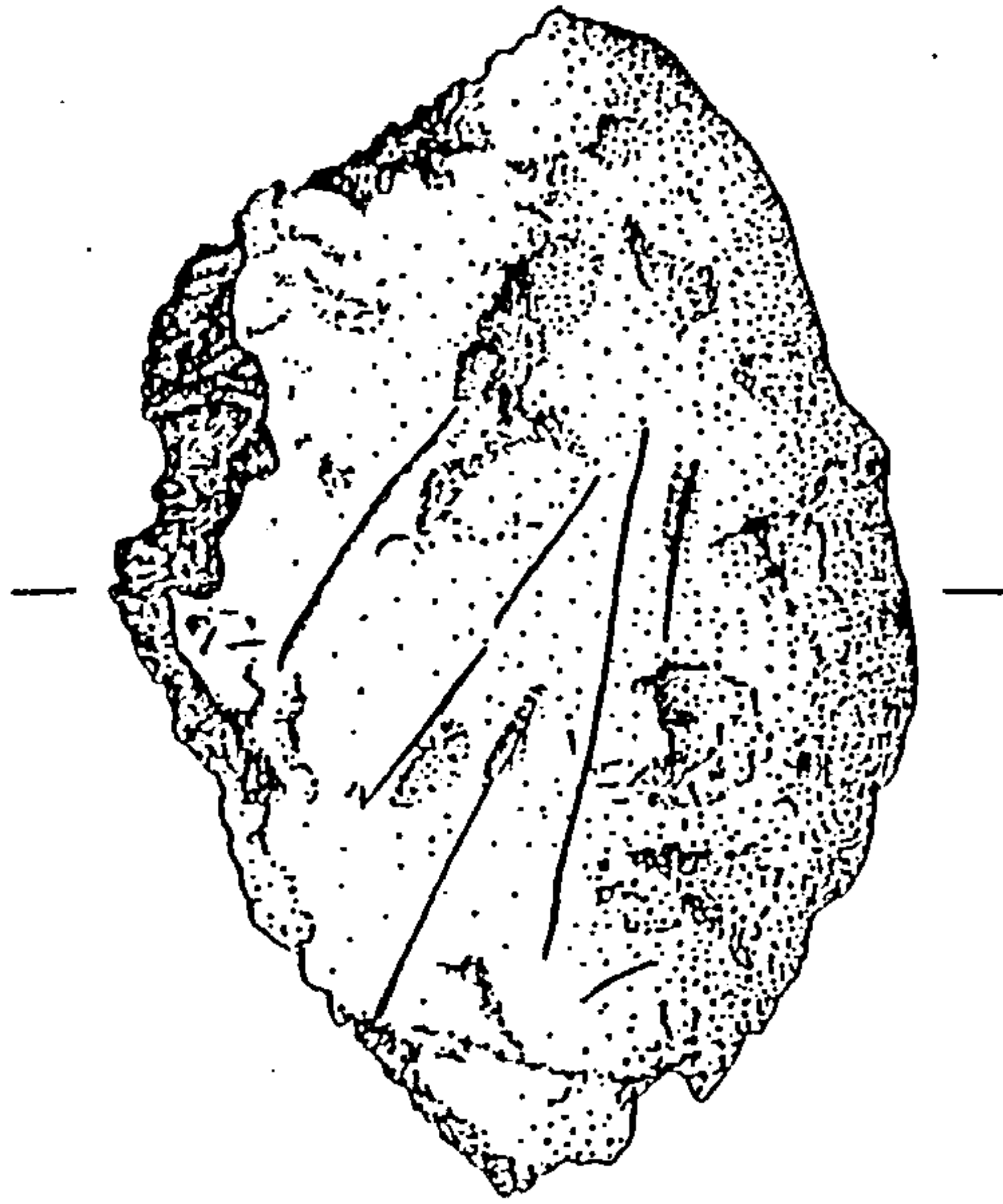
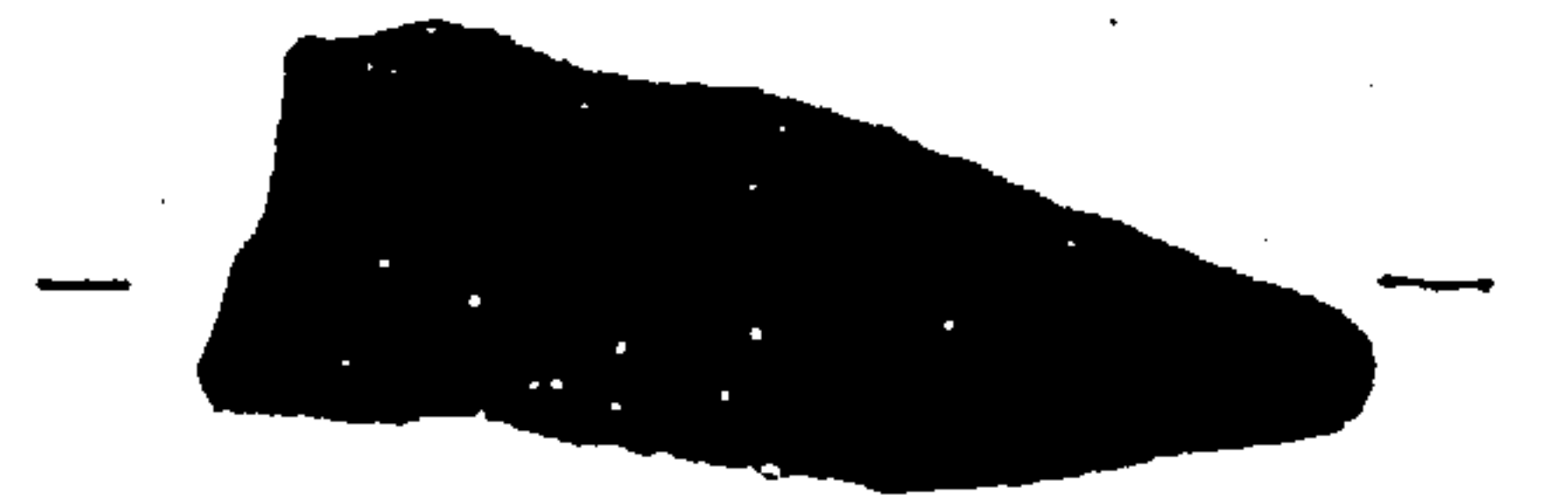
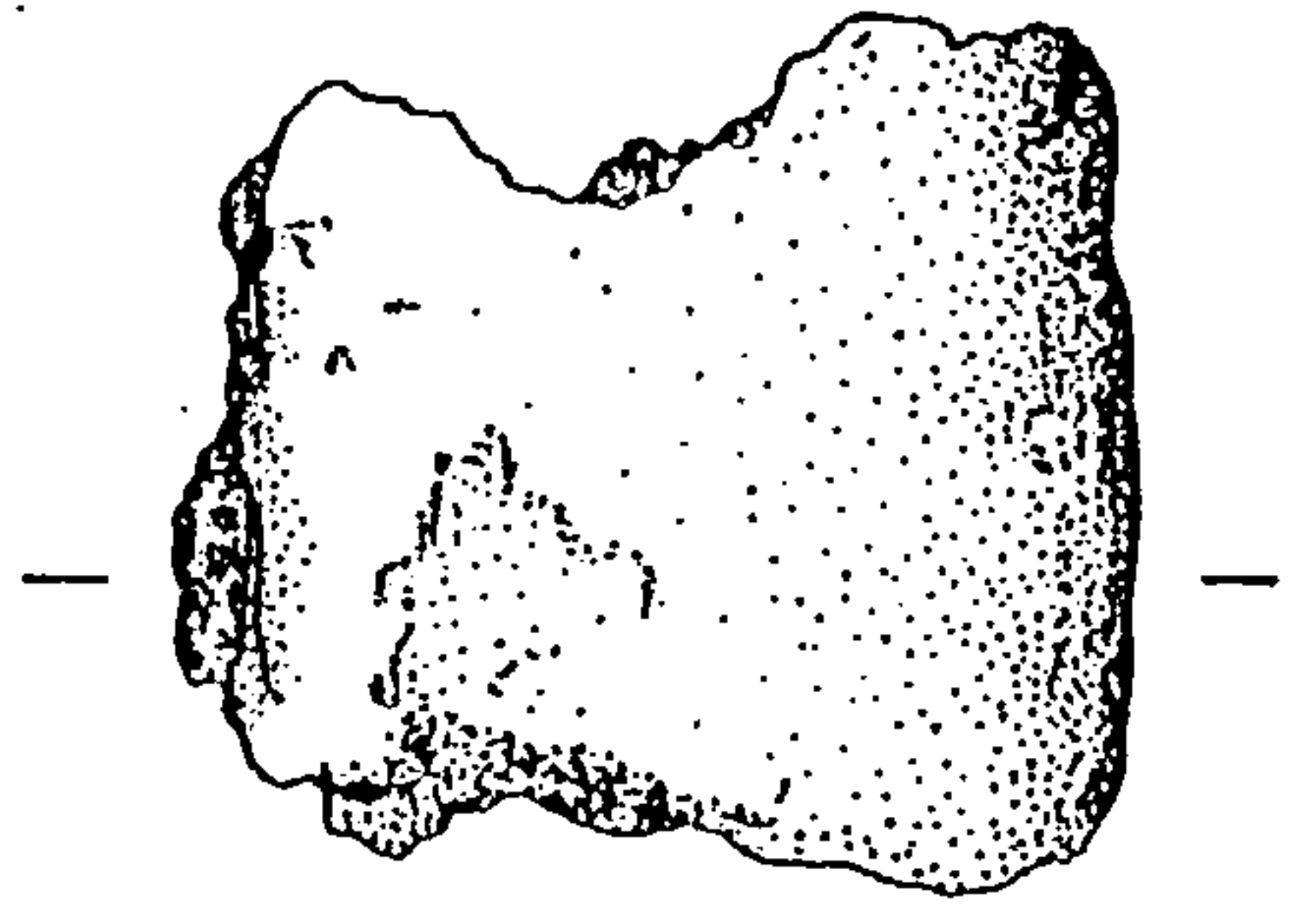


Fig. 5. The All Hallows I Hoard (Ref. No. 12): Weaponry and Small Tools

12/29

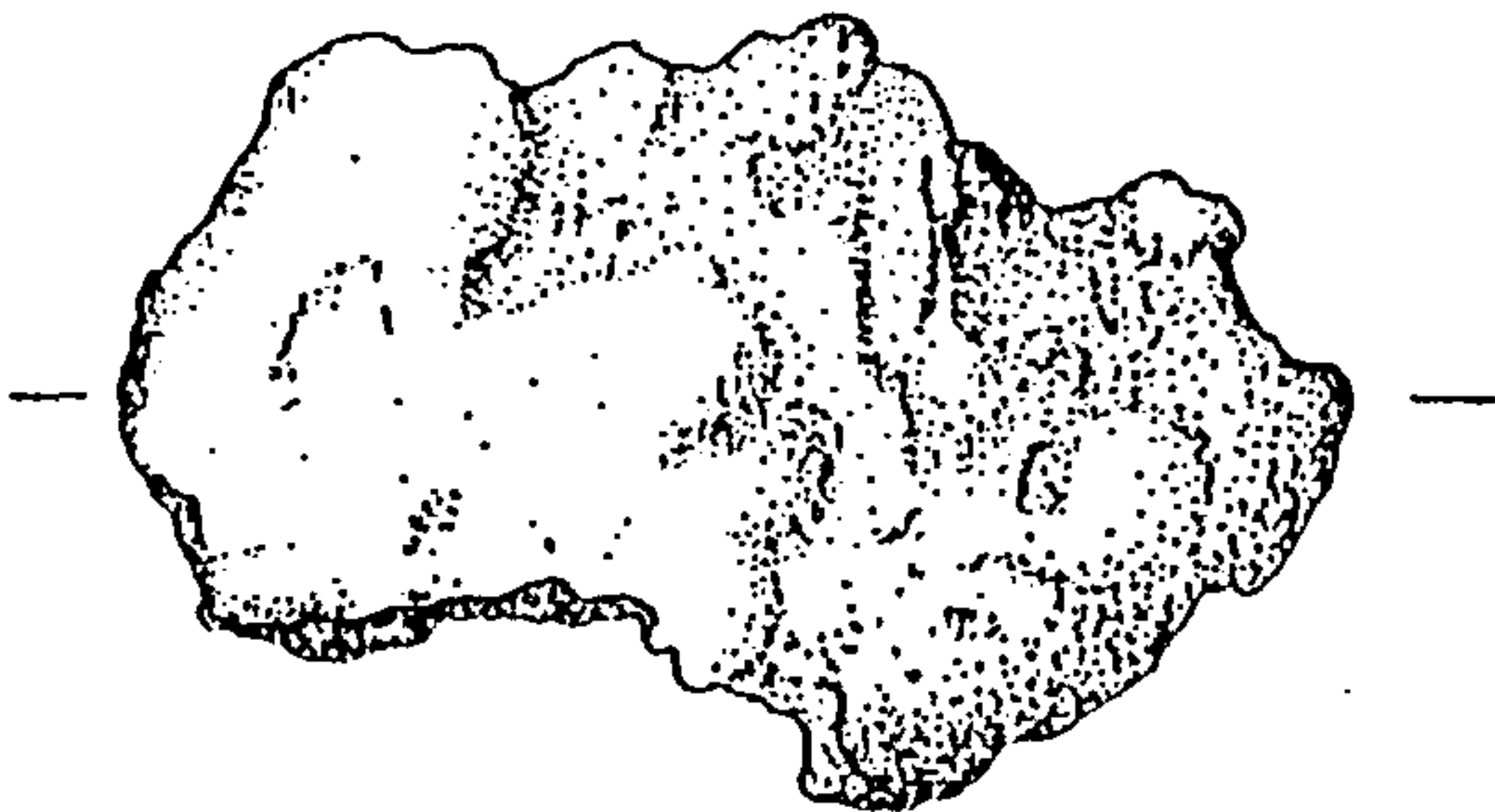


12/30



0 2cm

12/31



12/32

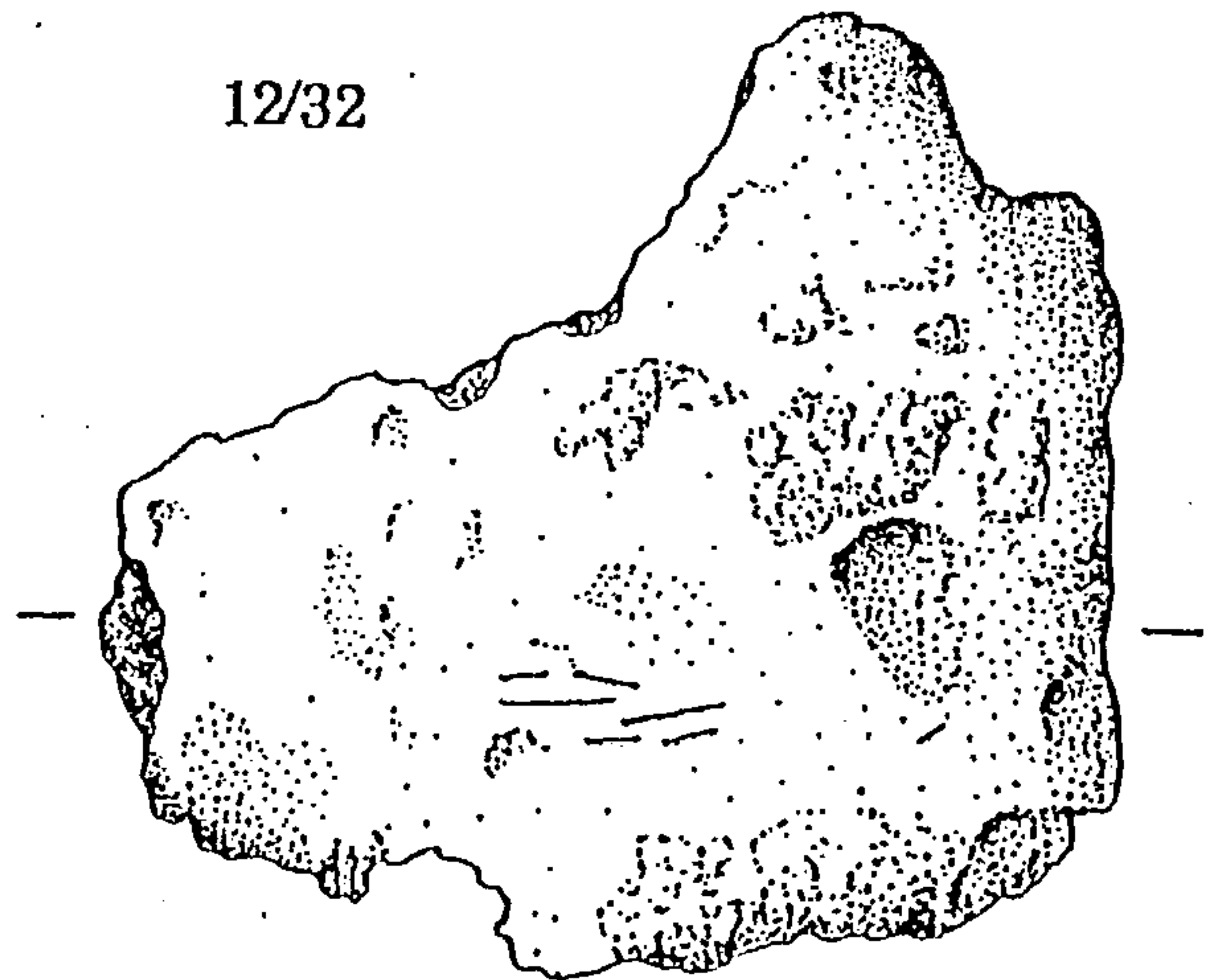
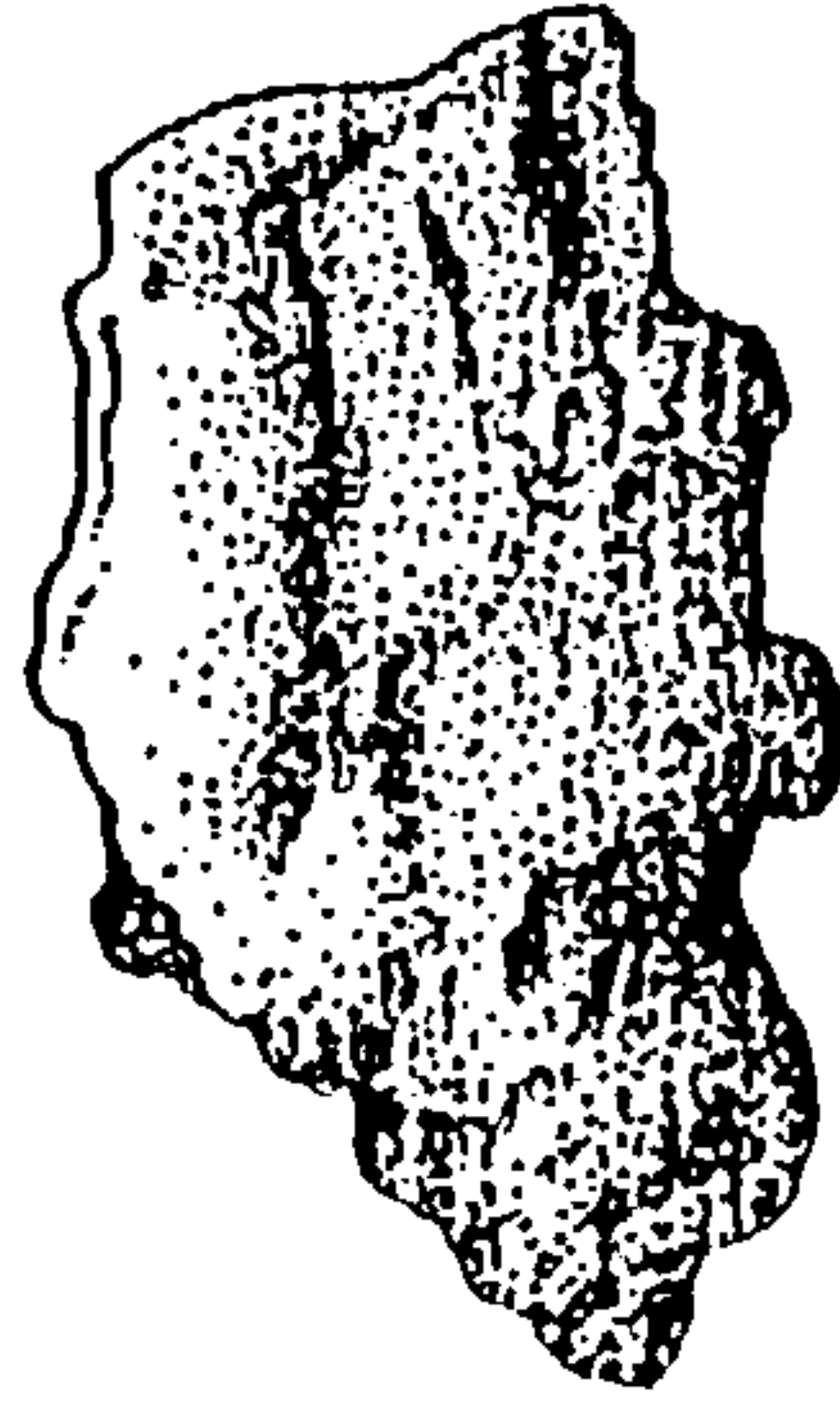


Fig. 6. The All Hallows I Hoard (Ref. No. 12): Ingot Metal (i)

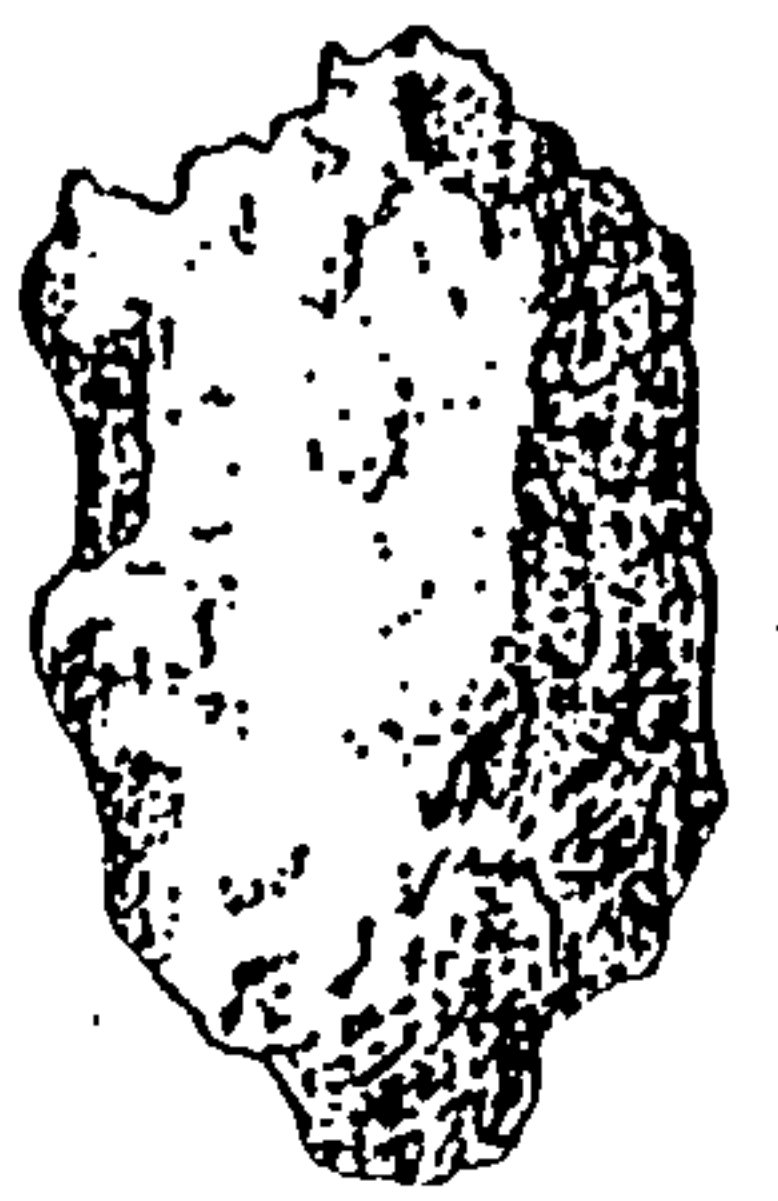
12/33



12/34

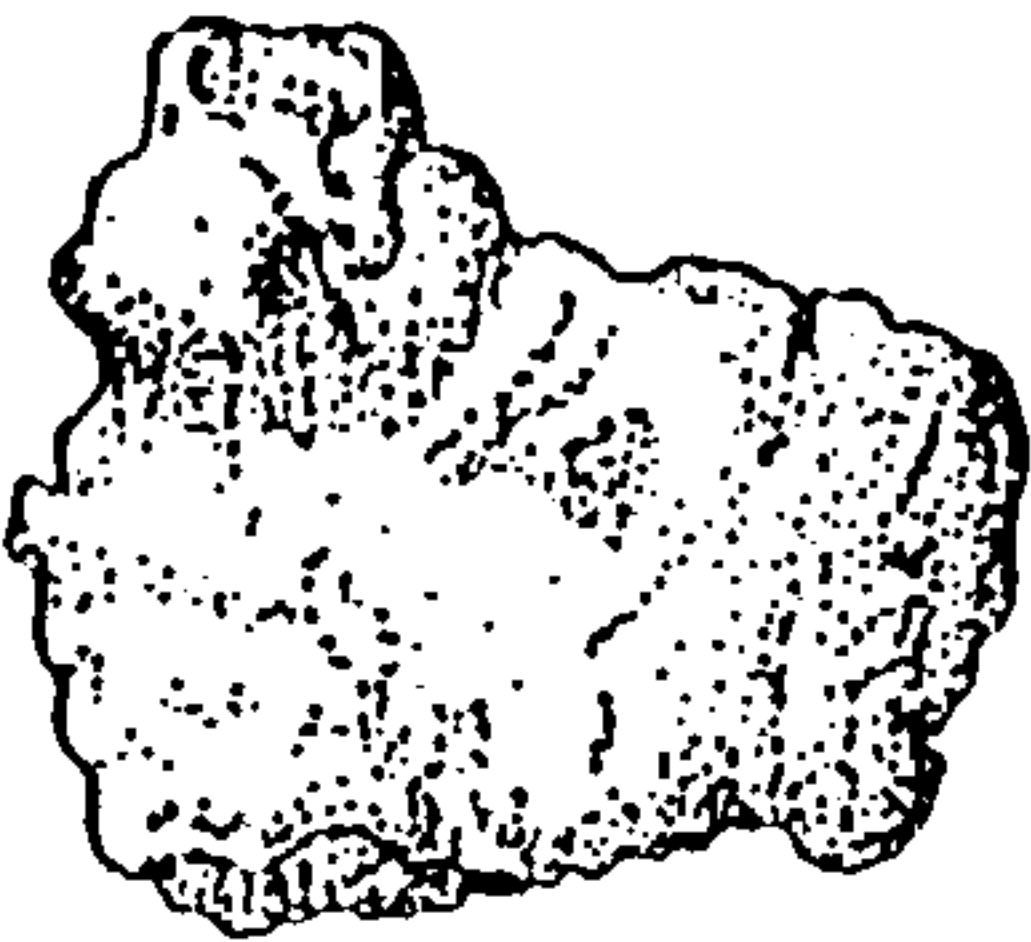


12/35

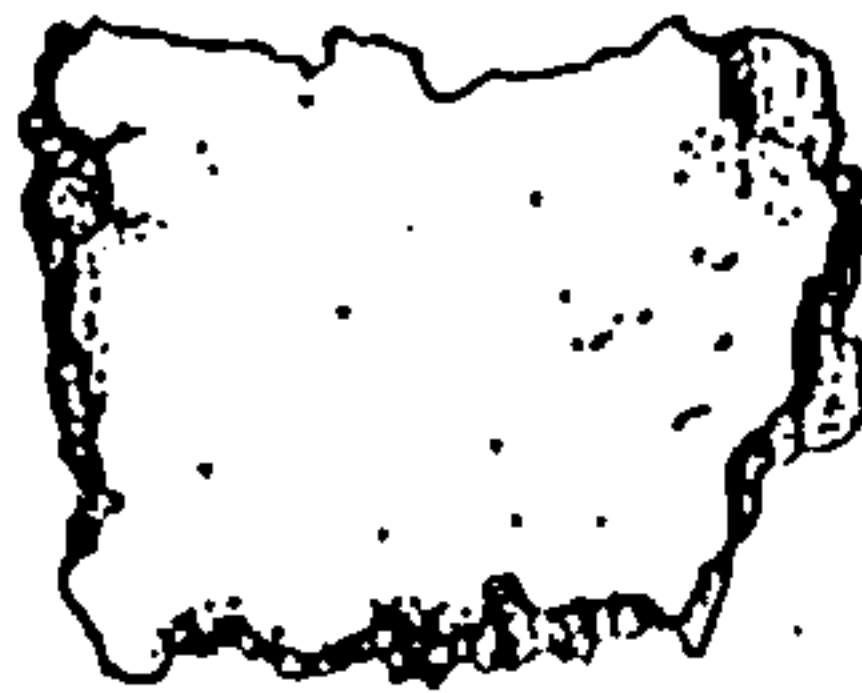


0 2cm

12/36



12/37



12/38

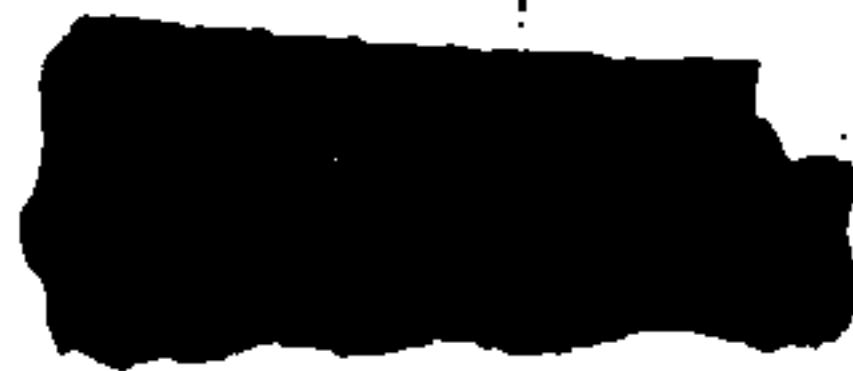
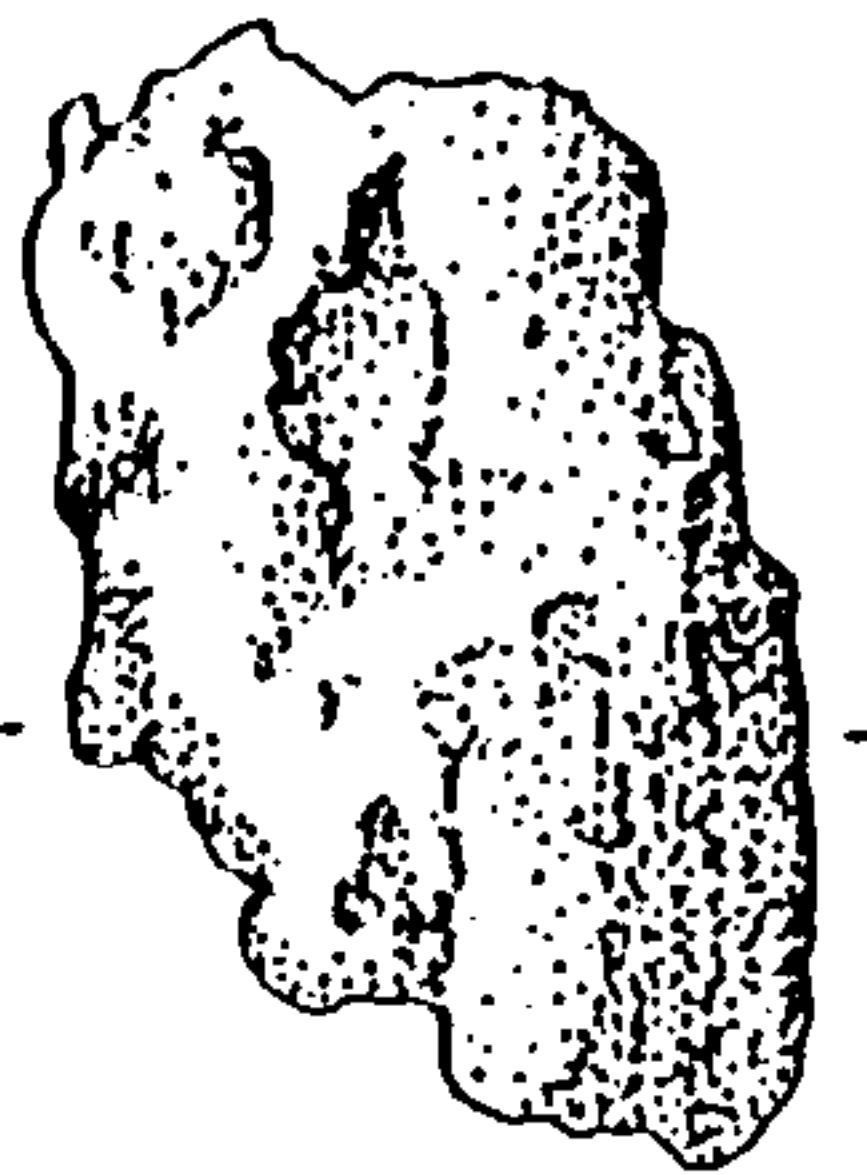


Fig. 7. The All Hallows I Hoard (Ref. No. 12): Ingot Metal (ii)

All Hallows II (Home Wood Farm) (Ref. No. 13)

Grid Reference: TQ 8305 7777 (centred).

Current Location: British Museum, Accession Numbers 94: 8-3: 30-52. There is some inconsistency apparent among documentation referring to the two All Hallows hoards. In some sources, All Hallows I appears to refer to the hoard from Home Wood Farm, while in others the hoard from Little Coombe Farm is described. In this instance, the hoard with the latest accession numbers is deemed to be All Hallows II, e.g. the Home Wood Farm hoard [c.f. All Hallows I, Ref. No. 12].

Context: Found by farm labourers.

Bibliography: Burgess and Colquhoun, 1988.
Jessup, 1930.
National Bronze Index.
Wickham, 1877.

Contents:-

13/01 (Acc. No. 94: 8-3: 33)

Description: Socketed axe, of faceted type.

Dimensions: Length: 98mm. Cutting edge: 46mm. Weight: 152.1g.

Patina: Corrosion stripped. Object is in very poor condition.

Manufacture: There are no traces of the loop. Instead, there is a gap in the metal here, and the rounded edges which surround this are suggestive of a casting flaw. The piece was used despite this potentially serious problem (see below). The mouth has been well-finished, and no traces of the casting seam survive, except for a short stretch between the collar and the area where the loop should have been. The cutting edge has been well-expanded.

Use: The blade is uneven in appearance, and has been damaged over its length, with some large notches missing from the cutting edge in places.

Reduction: The object is complete and there is no evidence pertaining to this process.

13/02 (Acc. No. 94: 8-3: 30)

Description: Socketed axe, of 'south-eastern' type, with three pellets set in a single horizontal row on either face. Two very prominent internal ribs are present, slightly offset with one another.

Dimensions: Length: 103mm. Cutting edge: 47mm. Weight: 286.2g.

Patina: Corrosion stripped, leaving a pitted surface. Details very poor.

Manufacture: The mouth is well-finished. The upper seam is problematic, with a stepped appearance to the section suggesting mould misalignment. The seams are visible on the underside, but they have been removed over the loop. The cutting edge has a rather crescentic appearance, with bevels visible over either corner, and yet the shape seems rather flat.

Use: The edge is blunt and chipped, and may have been resharpened a number of times.

Reduction: The object is complete, with no evidence pertaining to this process.

13/03 (Acc. No. 94: 8-3: 29)

Description: Socketed axe, of 'south-eastern' type, with a single pellet decoration on either face. Three collar mouldings are visible around the mouth.

Dimensions: Length: 112mm. Cutting edge: 41mm. Weight: 208.3g.

Patina: Corrosion now stripped, virtually all surface detail obliterated.

Manufacture: No observations can be made with any confidence. The uneven appearance to the mouth is likely to result from an inadequate supply of metal during casting. No trace of any seam survives over the lower surface, with the exception only of the junction between collar and loop, and this is likely to reflect the original situation. On the upper surface, the seam is visible over the collar mouldings, but it remains only as a pitted furrow elsewhere, suggesting damage caused or exaggerated by corrosion removal.

Use: The edge is unevenly worn, and seems quite blunt, though this latter characteristic may be exaggerated by the corrosion removal.

Reduction: The object is complete, with no evidence relating to this process.

13/04 (Acc. No. 94: 8-3: 34)

Description: Large portion of 'south-eastern' socketed axe, missing part of the body (including the loop), and most of the mouth. A single pellet decoration survives on one face, beneath two collar mouldings.

Dimensions: Length (maximum): 79mm. Cutting edge: 39mm. Weight: 87.0g.

Patina: Dense grey-green. Details reasonable.

Manufacture: The seams are still prominent. On the uppermost surface they have been obliterated over the final c.10mm back from the cutting edge, while on the underside they have been removed over roughly a third of the piece towards the blade. They remain prominent - though flattened - over the loop, with no traces surviving around the mouth. Some diagonal grinding marks are visible on the interface between the lower surface and one face (not illustrated), but otherwise little can be seen. The cutting edge is crescentic in appearance.

Use: The edge is chipped in places and rather blunt. Some of this damage may have originated recently as a result of flaking corrosion products.

Reduction: There are some isolated small tool marks on the surface, and hammering is evident near the break on the side illustrated. Some distortion of the metal is apparent in the vicinity of the loop on the other face, but no individual hammer marks can be seen.

13/05 (Acc. No. 94: 8-3: 32)

Description: Socketed axe of 'south-eastern' type, with a plain blade, and two roughly equal collar mouldings. Two ribs are apparent on the interior - one very sharp in appearance, the other less well-defined.

Dimensions: Length: 87mm. Cutting edge: 39mm. Weight: 176.9g.

Patina: The corrosion has been stripped, leaving a pitted surface. The detail has largely been obliterated as a result.

Manufacture: One wall seems slightly thinner in section, though not seriously so. The seams have been finished to some extent, but they remain prominent over much of the piece. They have been removed over the loop, however, and over the last c.10mm back from the cutting edge on either side. The cutting edge is narrow in width, and yet shows a deep, crescentic shape to the blade.

Use: Impossible to determine.

Reduction: A crack in the metal is evident near the mouth, and breakage has occurred here in recent times. This has since been mended with glue. The wall has been pushed outwards slightly in the vicinity of the break, and the mouth shows similar signs of distortion. This damage could be use-related, though it might result from attempts made to loosen the haft.

13/06 (Acc. No. 94: 8-3: 31)

Description: Socketed axe, of 'south-eastern' type, with plain blade. A single internal rib is visible, commencing not at the mouth, but on the wall some c.20mm below.

Dimensions: Length: 100mm. Cutting edge: 41mm. Weight: 185.3g.

Patina: Corrosion stripped, details poor.

Manufacture: The mouth is very uneven in appearance, and the metal seems thin near the break, indicating core misalignment and also an inadequate supply of metal during casting. The upper seam can be seen as a faint trace over the collar, but elsewhere only a slight step in the section is evident. The lower seam cannot be seen, but pitting from corrosion removal here may have obliterated much detail. The cutting edge is narrow, and yet shows a deep, crescentic shape.

Use: The blade is unevenly worn.

Reduction: Part of the mouth is now missing, and the metal is cracked in the vicinity of the break here. There has been a recent break near the mouth, and this has since been repaired by gluing. The damage which took place in antiquity may be use-related, the piece having broken at the metal's thinnest - and therefore weakest - point.

13/07 (Acc. No. 94: 8-3: 51)

Description: Socketed axe, of 'south-eastern' type, with much of the body, including the loop, now missing through breakage. A short rib is visible in the interior.

Dimensions: Length: 67mm. Cutting edge: 34mm.

Patina: Corrosion stripped, details largely obliterated.

Manufacture: The mouth is very uneven, the uppermost collar moulding now being barely visible on account of an inadequate supply of metal having been used during casting. One part of the mouth is so deformed as to resemble a feeder stump, but since the internal rib continues here, this seems likely to be part of the actual axehead. There are no traces of any seam, except for a very blunt and almost negligible ridge which runs along the uppermost surface near the mouth. The cutting edge seems well-expanded, and a blunt notch apparent at one end may be an additional casting flaw.

Use: The blade seems blunt and chipped along its length, but its poor condition is hardly improved by the fact that some damage has resulted from the later loss of corrosion product.

Reduction: A slight depression is visible near the break on one side (not illustrated), but there are no other indications.

13/08 (Acc. No. 94: 8-3: 44)

Description: Mouth and upper body fragment of 'south-eastern' type socketed axe.

Dimensions: Length (maximum): 65mm. Weight: 158.6g.

Patina: Dense light green, with some powdery brown patches of what appears to be clay or soil adhering. Details reasonable.

Manufacture: The mouth is rather uneven in appearance, indicating an inadequate supply of metal during casting. A slight fragmentary hole which survives as a vestigial trace on the lower break may also be a casting flaw, and one wall is markedly thinner, suggesting core misalignment. No seams or feeders remain around the mouth. The top seam is obscured by corrosion products, though there is a slight stepped appearance here. The lower surface shows faint traces of a seam over the collar and the area before the break, but the seam is absent over the loop.

Use: Impossible to determine.

Reduction: The lower break shows little distortion to the section, but a marked depression is visible above this on either face, running from just above the break to the start of the loop. On one face (illustrated), there are also signs of crushing at the mouth, and the metal has split here. The piece has been hammered, but in addition there are some sharper gashes visible in the metal, just below the lower moulding on the side illustrated.

13/09 (Acc. No. 94: 8-3: 45)

Description: Mouth and upper body fragment of socketed axe, probably of 'south-eastern' type, with part of the wall now missing. An internal rib is present.

Dimensions: Length (maximum): 56mm. Weight: 111.5g.

Patina: Rough light green, with a thick layer of encrustation. Details virtually obliterated.

Manufacture: One wall - the one which is incomplete - is considerably thinner, showing clear indications of core misalignment. Traces of the casting seam and the feeders are apparent around the mouth. On the body, the upper seam has been flattened, but it remains obvious, while the lower seam is difficult to discuss as the condition of the surface is so poor here, though its line can be traced. One unique feature with this piece is a series of regular striations visible on the metal inside the mouth of the piece. These appear to have been made in antiquity, as they are patinated, and they are quite clear. However, their awkward location meant that they could not be examined under a hand-lens and so they must remain somewhat problematic.

Use: Impossible to determine.

Reduction: One face has been completely crushed inwards, and a large section of the wall has broken away here as a result of this. The section at the lower break is distorted, with the surviving section of the wall pushed inwards. In this example, damage appears to have been concentrated upon one side of the object.

13/10 (Acc. No. 94: 8-3: 53)

Description: Mouth fragment of socketed axe, probably of 'south-eastern' type.

Dimensions: Length (maximum): 39mm. Weight: 59.8g.

Patina: Rough grey-green, details obliterated.

Manufacture: The wall seems too thin, indicating core misalignment. The mouth is neatly finished, while the seams remain obvious on both sides.

Use: Impossible to determine.

Reduction: The piece has been crushed inwards, and it seems likely that prior to this process it remained as a complete upper body fragment. Subsequent hammering split this surviving portion in half. The metal of the collar is slightly cracked where maximum distortion has occurred.

13/11 (Acc. No. 94: 8-3: 46)

Description: Mouth fragment of socketed axe, probably of 'south-eastern type'.

Dimensions: Length (maximum): 54mm. Weight: 123.9g.

Patina: Rough grey-green, with much encrustation evident, though there are occasional denser patches near the lower break.

Manufacture: No indications of any casting defects are evident. The mouth seems quite uneven, but this may be the result of corrosion build-up. The top seam remains sharp and prominent, though it is obscured by the corrosion over the collar. The lower seam also may be rather prominent, but again it is obscured by corrosion over much of its length.

Use: Impossible to determine.

Reduction: The piece has been hammered inwards at either side in the vicinity of the lower break, and the section is now much distorted as a result. Hammering is also apparent near the mouth, and this has caused cracking of the metal in the areas where the depression is most marked.

13/12 (Acc. No. 94: 8-3: 52)

Description: Mouth fragment of socketed axe, possibly of 'south-eastern' type, with the loop surviving as no more than a fragmentary stump.

Dimensions: Length (maximum): 29mm. Weight: 36.1g.

Patina: Pale green, rather rough. Few details visible.

Manufacture: There is a rather uneven appearance to the mouth, which may result from an inadequate supply of metal during casting, and the wall seems rather thin. The seam remains prominent over the collar.

Use: The breakage of the loop may be use-related.

Reduction: No traces of this process can be identified.

13/13 (Acc. No. 94: 8-3: 37)

Description: Socketed chisel, with a flared mouth and single collar moulding, and with a faceted appearance to the section.

Dimensions: Length: 58mm. Cutting edge: 25mm. Weight: 30.5g.

Patina: Dense grey-green, details locally good.

Manufacture: Very well-finished, with no visible traces of any casting seams. There are indications of fine hammering and chisel marks over the surfaces, and also possible grinding marks on one 'facet'. A slight depression above the blade is probably the result of hammer-working.

Use: The edge is reasonably good, and it remains quite sharp, though it is slightly uneven. Cracking in the metal - with no accompanying distortion - may be use-related.

Reduction: The cracking of the blade and the small tool marks could have resulted from damage inflicted at this stage of the object's life.

13/14 (Acc. No. 94: 8-3: 35) An accompanying note states that the object was found in an unprovenanced drawer in 1992, and matched with 94: 8-3: 35 by comparison with a drawing in the NBI)

Description: Socketed gouge, with faint traces of a collar moulding in places, and a wide blade.

Dimensions: Length: 77mm. Blade: 25mm. Weight: 71.0g.

Patina: Corrosion stripped, details as a result are very poor.

Manufacture: The seams appear to have been completely removed. There are possible indications of vertical grinding marks running down the interior of the blade. These are difficult to make out, but their presence seems likely, given comparisons with better-preserved socketed gouges in other hoards. The mouth has an uneven appearance, but this may result from recent removal of the corrosion product.

Use: The blade seems quite blunt and uneven, and the break in the mouth appears to result from use-related damage - it is very rough in appearance and is not associated with any hammering.

Reduction: There is a noticeable indentation just behind the edge of the blade, and this appears to have been caused by a hammer blow (fig.1), probably linked with this stage of the object's life-cycle.

13/15 (Acc. No. 94: 8-3: 36)

Description: Socketed gouge, with a slightly flared appearance to the mouth.

Dimensions: Length: 75mm. Blade Width: 17mm. Weight: 58.8g.

Patina: Dense olive, with some pale green and brown mottled patches. Details reasonable.

Manufacture: The mouth is smooth and well-finished, but elsewhere traces of the seams are apparent on either side of the piece. There are vertical grinding marks running down the interior of the blade, and indications of fine hammer working visible on the blade edge, which is slightly flared in appearance.

Use: The blade is chipped, and a notch is missing from it, in a similar location to the damage seen in 13/14. Slight cracking of the metal near the blade edge may result from use-related strain. There is also an isolated striation running close to the collar.

Reduction: One small tool mark is visible near the front of the piece, but no other evidence can be linked with this process.

13/16 (Acc. No. 94: 8-3: 48)

Description: Hilt and shoulders from sword of Ewart Park type. 4 rivet holes remain intact in the shoulder, the 2 lowermost ones being markedly larger, and the piece shows blunted ricasso notches below the shoulder.

Dimensions: Length (maximum): 81mm. Weight: 105.4g.

Patina: Rough grey-green, details poor.

Manufacture: All traces of the seams have been removed, with no other evidence present.

Use: One edge seems very good, with only a slight notch at the top. The other is very poor over the lower half of its length, and with the cutting edge completely absent here.

Reduction: There is slight distortion evident in the profile at the lowermost break, and marked hammer indents are visible on either side of the piece at the upper break.

13/17 (Acc. No. 1941: 8-3: 41)

Description: Blade fragment from leaf-shaped sword, probably of Ewart Park type.

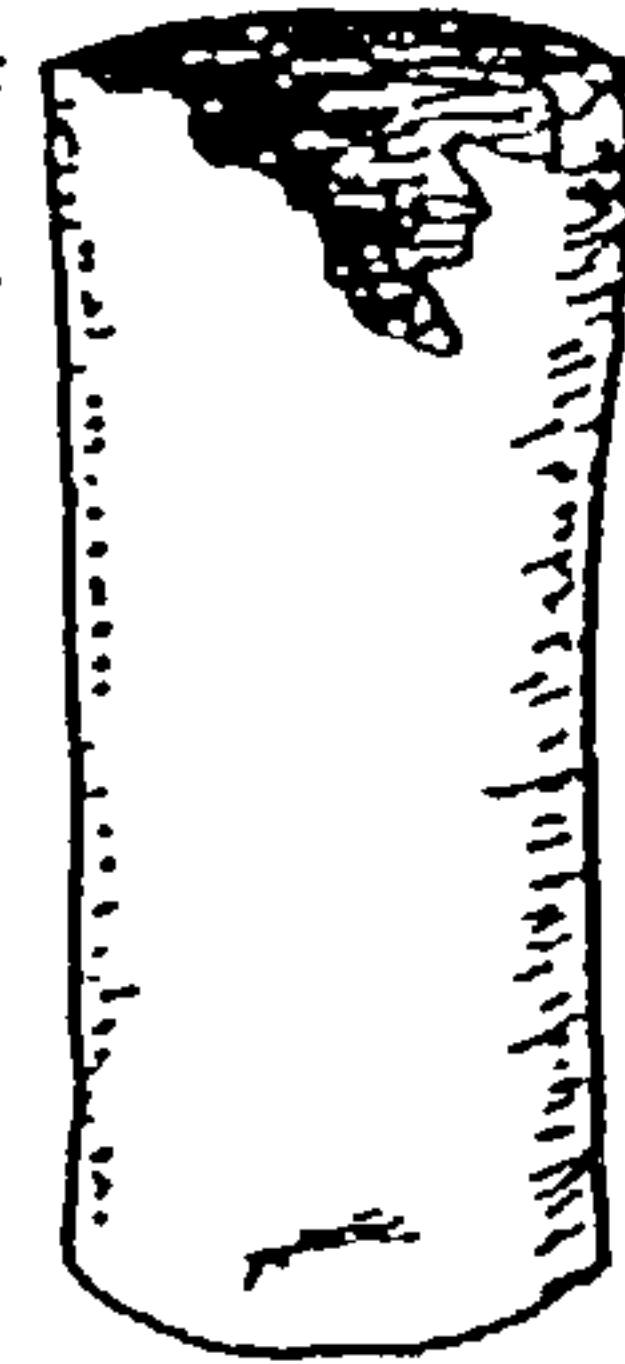
Dimensions: Length (maximum): 88mm. Weight: 106.9g.

Patina: Thick grey-green, details largely obscured.

Manufacture: The piece looks finely worked, but no hammer marks can be seen. There are bevels running down either edge, and, on both faces, vertical and diagonal grinding marks are visible.

Use: The blade shows a number of sharp notches on both edges, and these appear to have resulted from damage inflicted in antiquity. There is an additional blunt rounded notch evident, though, which is less easy to identify. What caused this cannot be ascertained.

Fig. 1



Reduction: There is a faint bow to the profile, but no signs of hammering on either break, save for one indentation near the upper break (not illustrated), and this could be a hammer mark.

13/18 (Acc. No. 1941: 1941: 8-3: 39)

Description: Fragment of sword blade, probably of Ewart Park type, broken into two adjoining parts.

Dimensions: Length (maximum): 96mm. Combined Weight: 109.0g.

Patina: Very rough grey-green, no details visible.

Manufacture: Faint bevels can be seen on the blade edges.

Use: Little if any of the original edge remains intact. On one side of the upper fragment (depicted here on the left-hand side), some of its extent remains quite sharp, but where this edge continues on the lower piece it is blunted and battered. The other side is notched and battered over its entire length. Some of this damage may result from later flaking away of corrosion product, but much seems to date from antiquity.

Reduction: There is a marked bend to the profile, but no indications of hammering can be seen near any of the breaks.

13/19 (Acc. No. 94: 8-3: 42)

Description: Small fragment of sword blade, probably of 'Ewart Park' type.

Dimensions: Length (maximum): 39mm. Weight: 51.7g.

Patina: Rough light-green, no details visible.

Manufacture: Impossible to determine.

Use: One edge is very blunt in appearance, while the other seems notched and battered over its length. Some of this may be attributable to recent damage, as the patina is absent, with fresh metal showing. There are possible horizontal striations running across the surface.

Reduction: The profile is distorted through bending, but there are no visible indications of hammering, possibly because the patina is so thick.

13/20 (Acc. No. 94: 8-3: 47)

Description: Blade fragment of sword, probably of Ewart Park type.

Dimensions: Length (maximum): 57mm. Weight: 64.2g.

Patina: Rough grey-green, details totally obscured.

Manufacture: Bevels are apparent on either edge, though while on one it appears very pronounced, while on the other it is not so clearly visible.

Use: Some of the original edge survives on one side, though it is badly notched and chipped over its length. Some of this damage may have occurred recently, as the patina is absent. The other cutting edge is completely absent, and the piece is blunt over its length.

Reduction: There are no visible indications of hammering, but any indents are likely to have been hidden by the corrosion product. No distortion is apparent in the profile.

13/21 (Acc. No. 94: 8-3: 40)

Description: Large piece of 'Carp's Tongue' sword blade, with the midrib defined by incised lines.

Dimensions: Length (maximum): 101mm. Weight: 133.5g.

Patina: Some bronze remains visible, though the piece is mainly dull olive with occasional patches of encrustation.

Manufacture: There are vertical grinding marks apparent, running down the blade and the midrib.

Use: Some marked notches on the cutting edge look like damage caused by a similar sharp-edge object, possibly through active use in combat. The remainder of this edge is good, but the other edge shows marked blunting and burring throughout much of its length.

Reduction: Slight distortion of the profile is apparent. Some small tool marks are visible, and there are hammer indents visible on the midrib.

13/22 (Acc. No. 94: 8-3: 50)

Description: Fragment of 'Carp's Tongue sword blade, with the midrib defined by grooves along its length.

Dimensions: Length (maximum): 37mm. Weight: 39.0g.

Patina: Rough pale green with large lumps of encrustation apparent. Details virtually obliterated.

Manufacture: No details can be seen through patina.

Use: The condition of the blade is obscured by corrosion products. There is one notch present which appears to date to antiquity, though another sharper example results from more recent damage.

Reduction: Faint distortion of the blade profile is apparent.

13/23 (Acc. No. 94: 8-3: 49)

Description: Bronze semi-circular fitting, which would have been riveted into place at either end using two tab-like attachments. Its dimensions and appearance would not be inconsistent with a sword pommel.

Dimensions: 34mm in width, and 34mm in depth (including tang). Weight: 23.6g.

Patina: Dense grey-green, details poor.

Manufacture: A fine casting, beautifully finished.

Use: One tab appears uneven, perhaps as a result of breakage. A faint crack runs down the casting in one place.

Reduction: There are no indications of deliberate breakage.

13/24 (Acc. No. 94: 8-3: 43)

Description: Hog-backed knife, hole slightly off-centre.

Dimensions: 78x42mm. Weight: 71.8g.

Patina: Mainly rough-olive, with some smoother patches, but the details are largely poor.

Manufacture: The hole has been punched through off-centre, and has in fact missed the hollowed area which marks its correct position. The top edge seems very rough and asymmetrical, and this might be due to an inadequate supply of metal for the casting. One face has a marked furrow running parallel to the edge - this may be a casting flaw (mould valves poorly aligned?) though it may be due to the inadequate removal of a casting seam (fig. 2). There are possible horizontal and vertical grinding marks visible where the patina is in a reasonable condition. There are no further indications of any casting seams. Altogether, this seems like a rather poor quality piece.

Use: The edge and sides appear chipped and blunted.

Reduction: No evidence can be linked with this process.

13/25 (Acc. No. 8-3: 38)

Description: Socketed spearhead, with a rather stumpy appearance.

Dimensions: Length: 76mm. Weight: 30.8g.

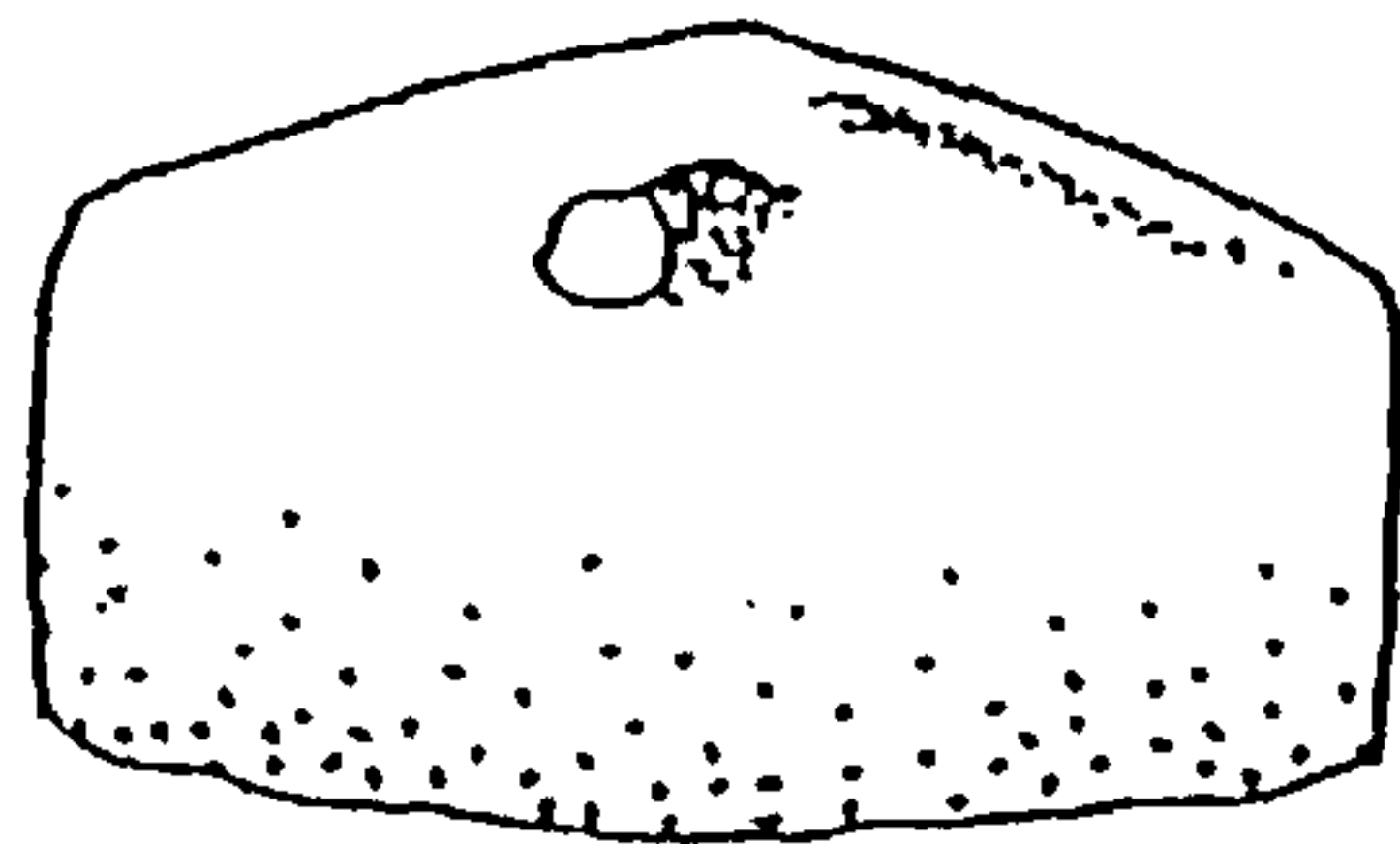
Patina: Rough mottled olive-brown and light green, with details badly obscured.

Manufacture: The edge of the socket has been beautifully finished, though a slight dip here may indicate a casting flaw. There are faint indications of a seam on one side.

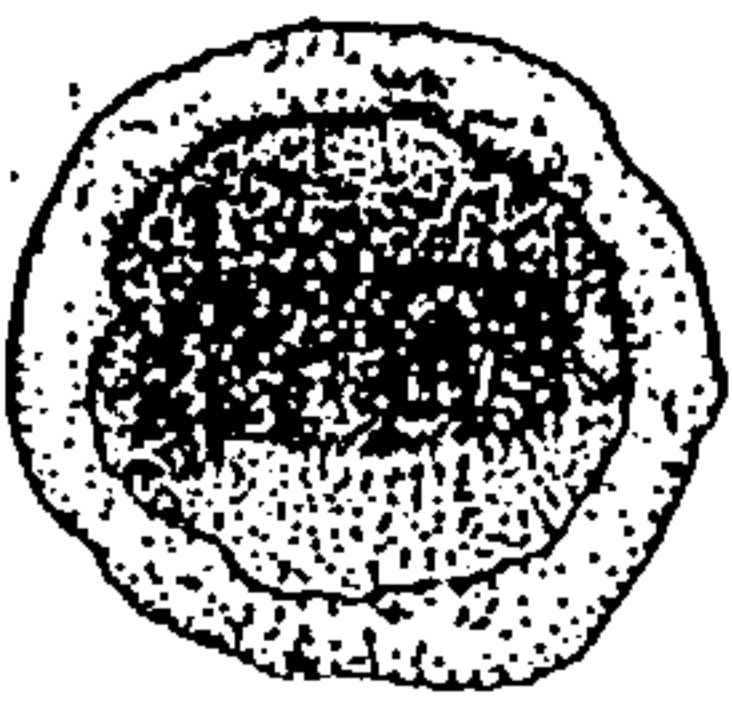
Use: The cutting edges are in poor condition. They are badly notched, and seem to have a slightly undulating appearance. The break in the socket could be use-related.

Reduction: There are slight hammer dents visible on the midrib, at a point measuring roughly one third of the way down the blade (not illustrated). The damaged edges might result from deliberate damage rather than through use, as the distortion appears to have been caused by a blunt object. There is a furrow visible in the midrib on one side (illustrated), but no indications of hammering are visible here.

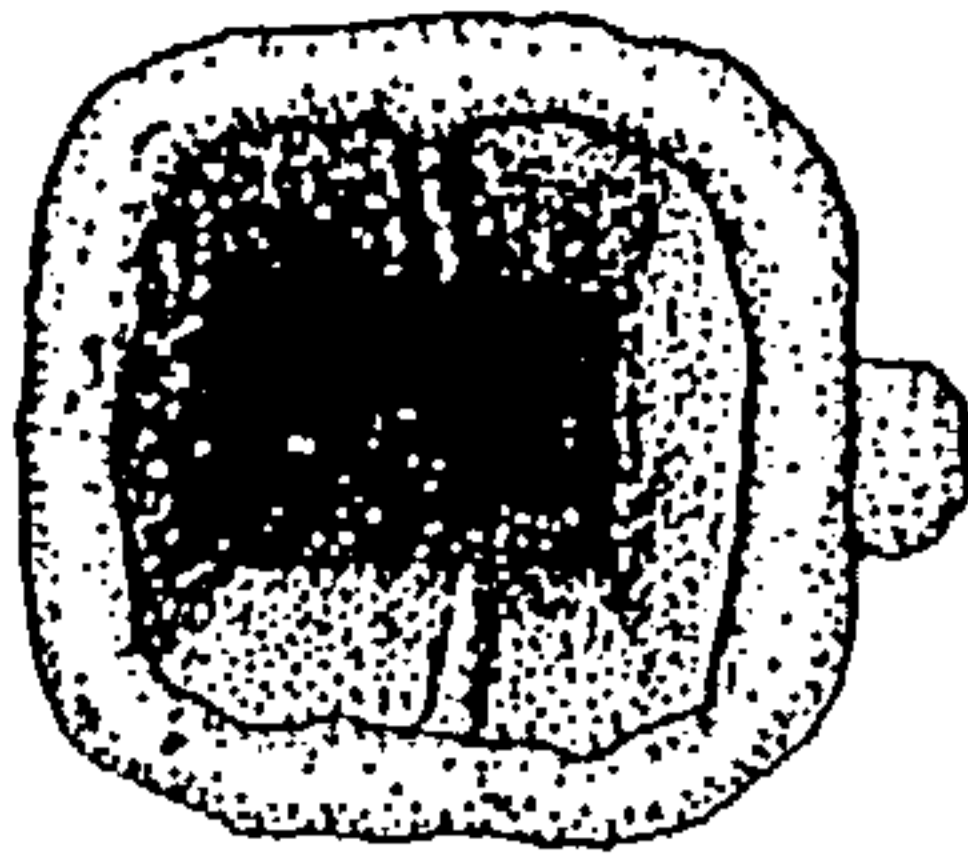
Fig. 2



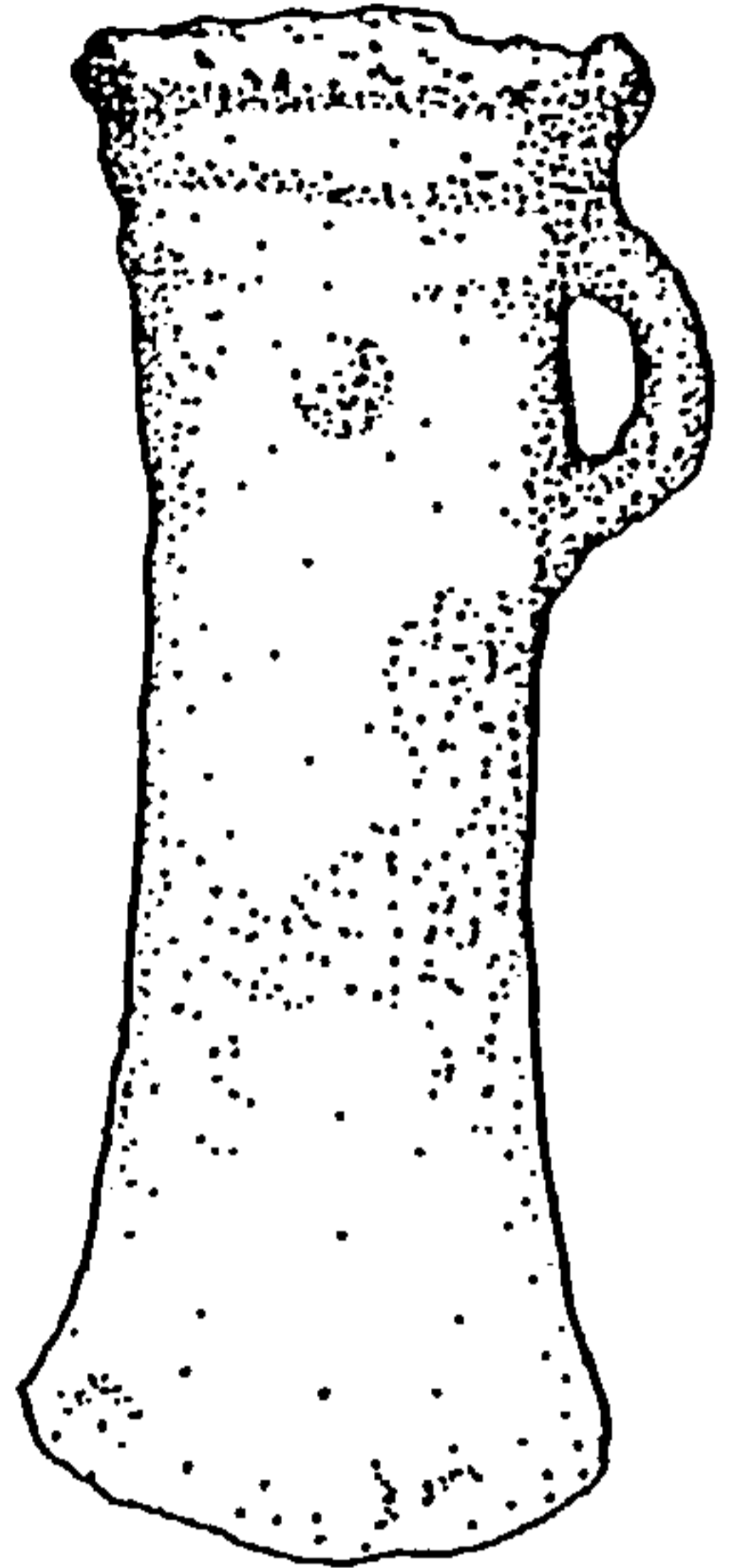
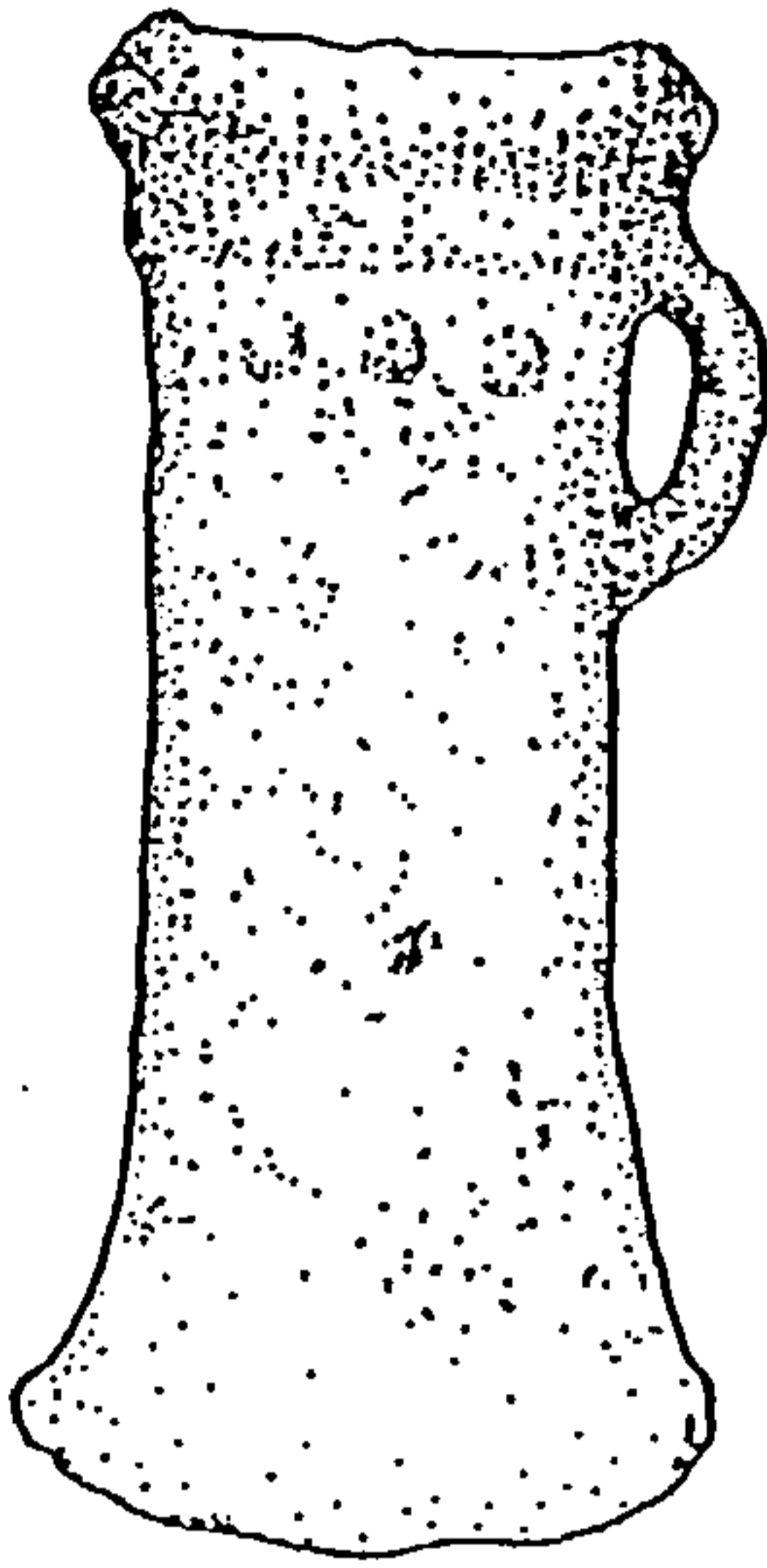
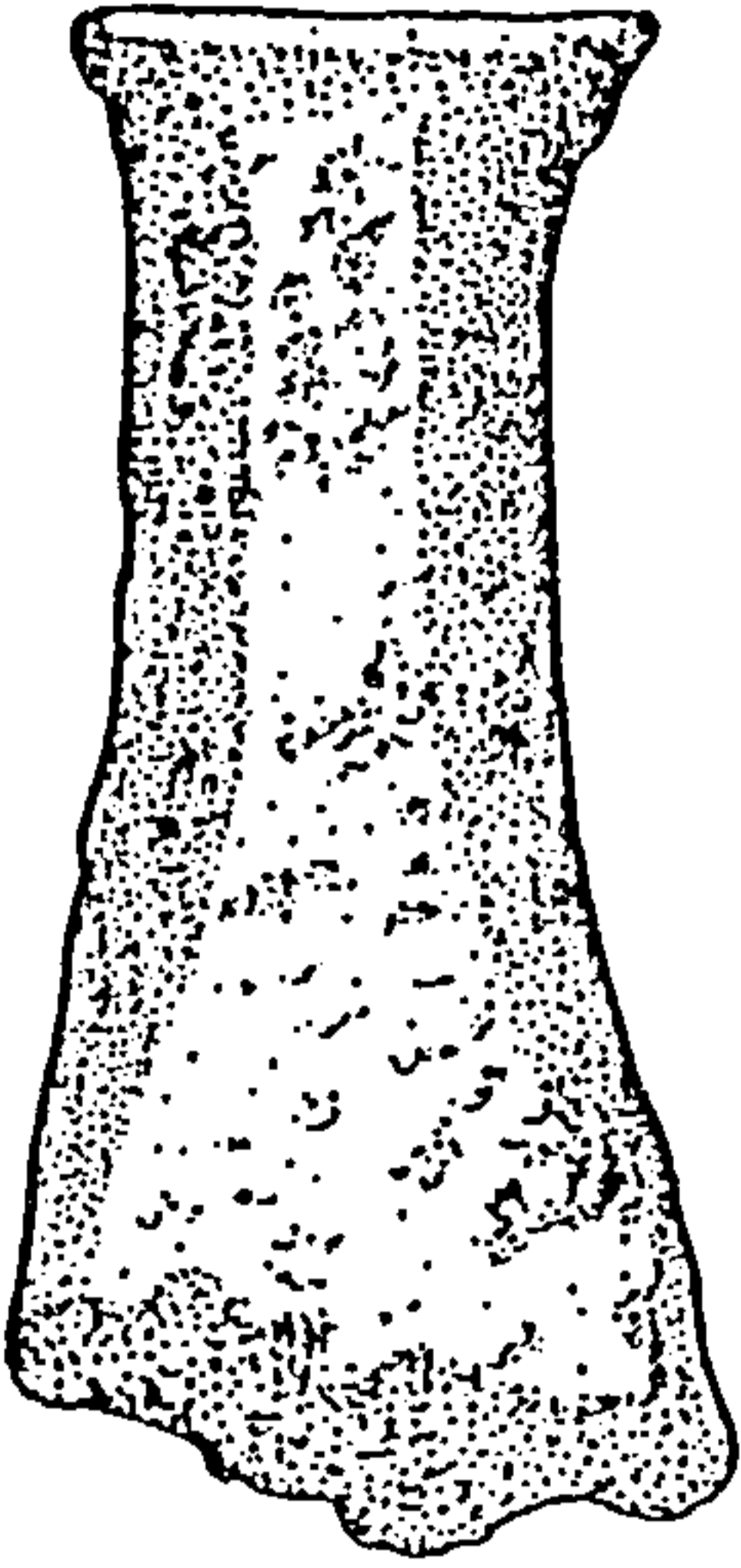
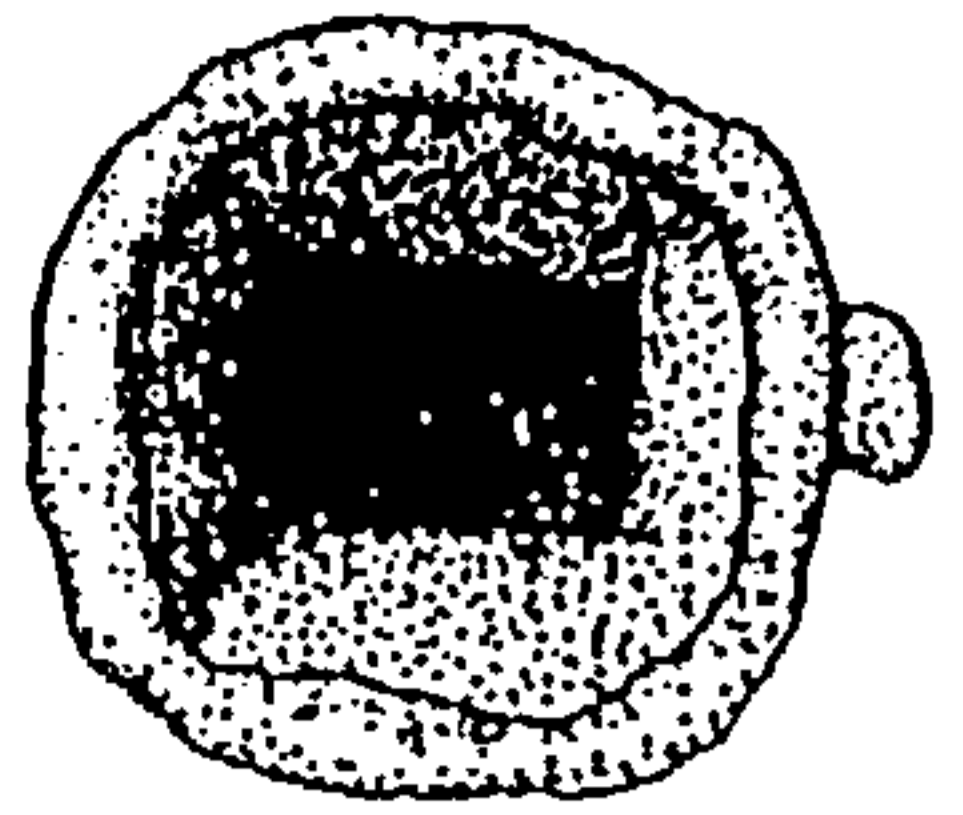
13/01



13/02

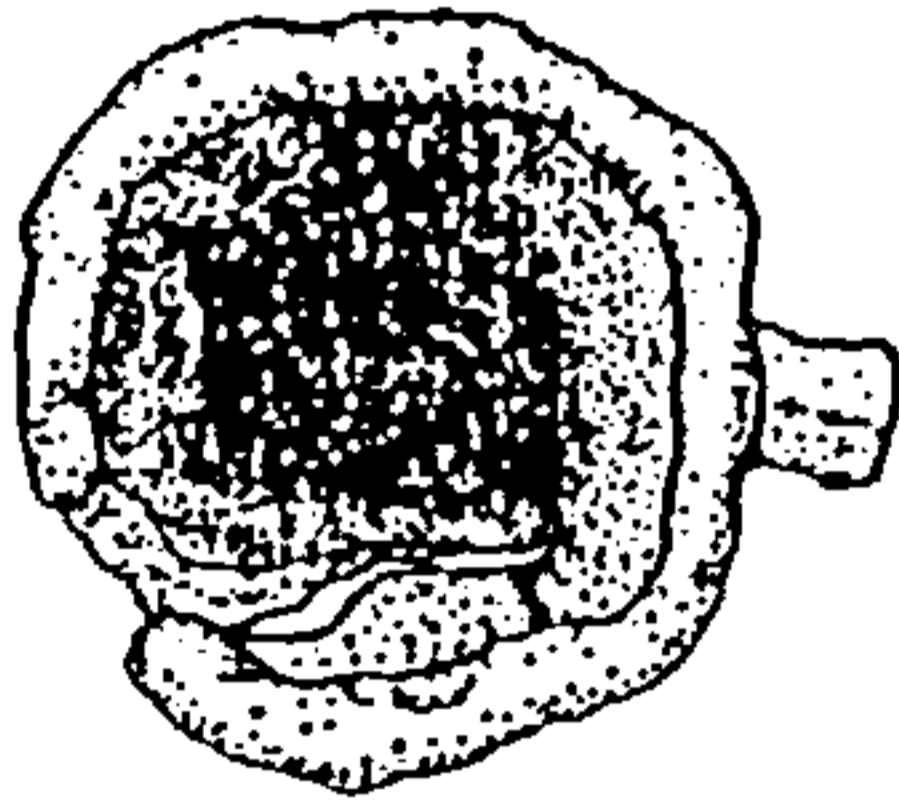


13/03



0 2cm

13/05



13/06



13/07



13/04

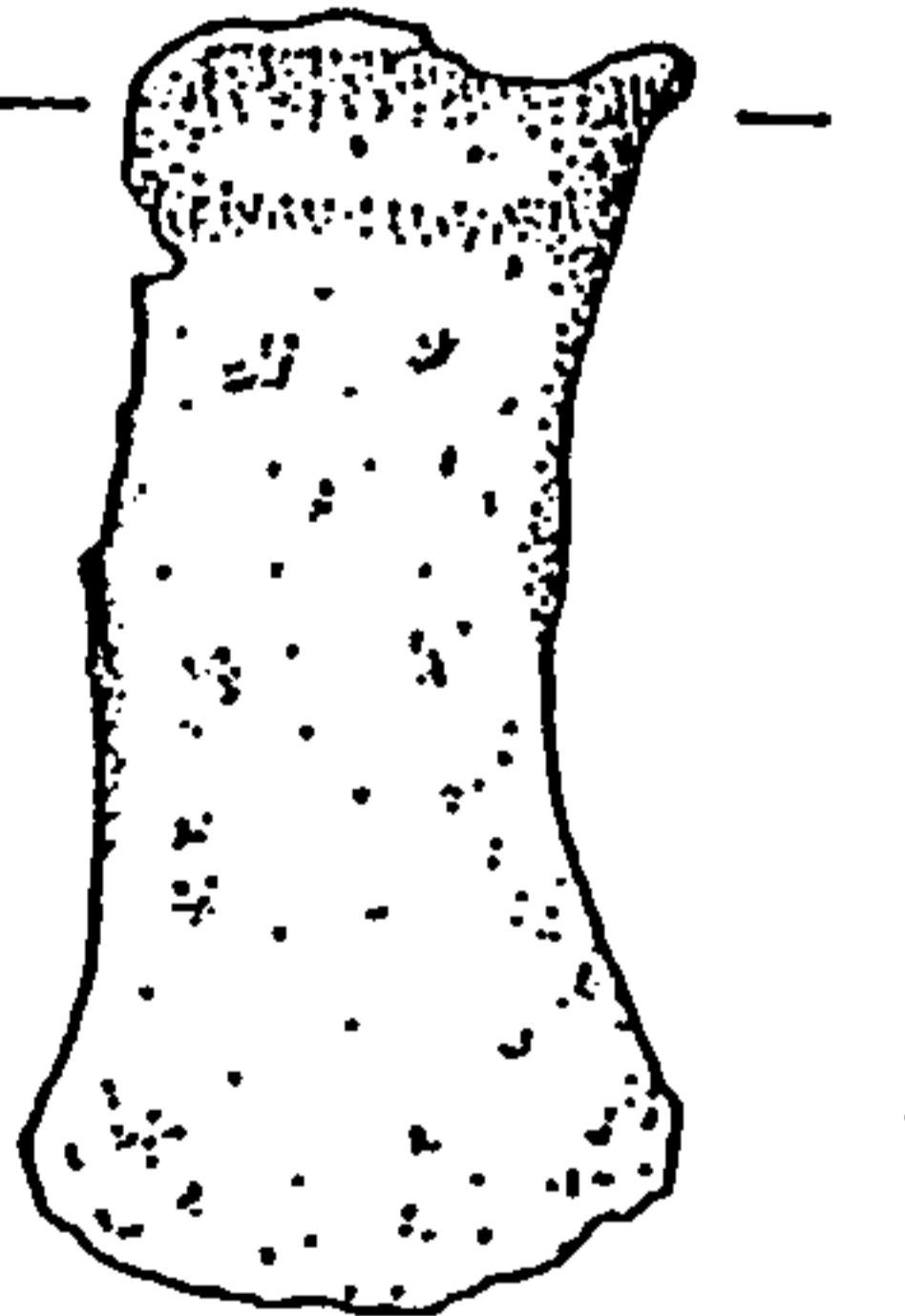
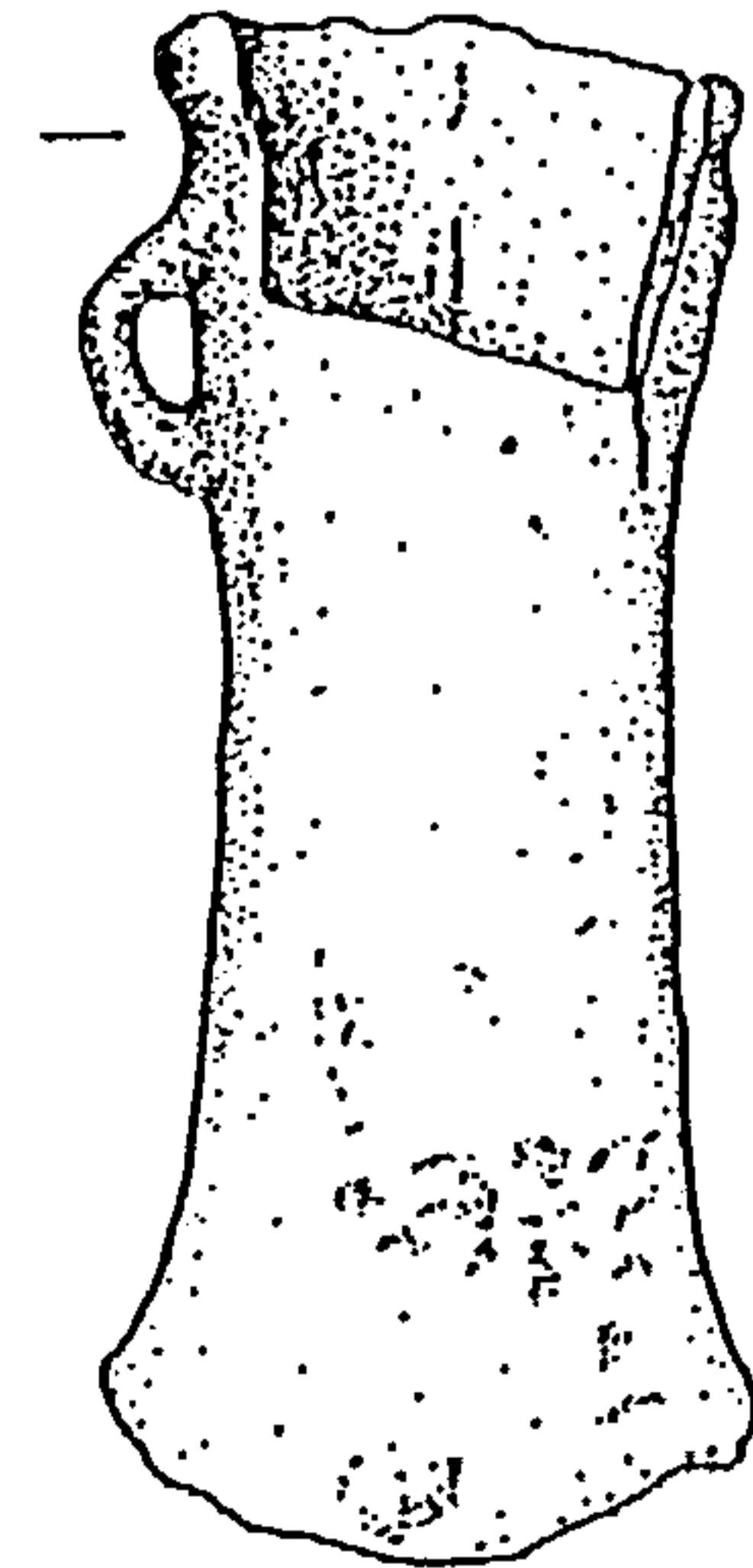
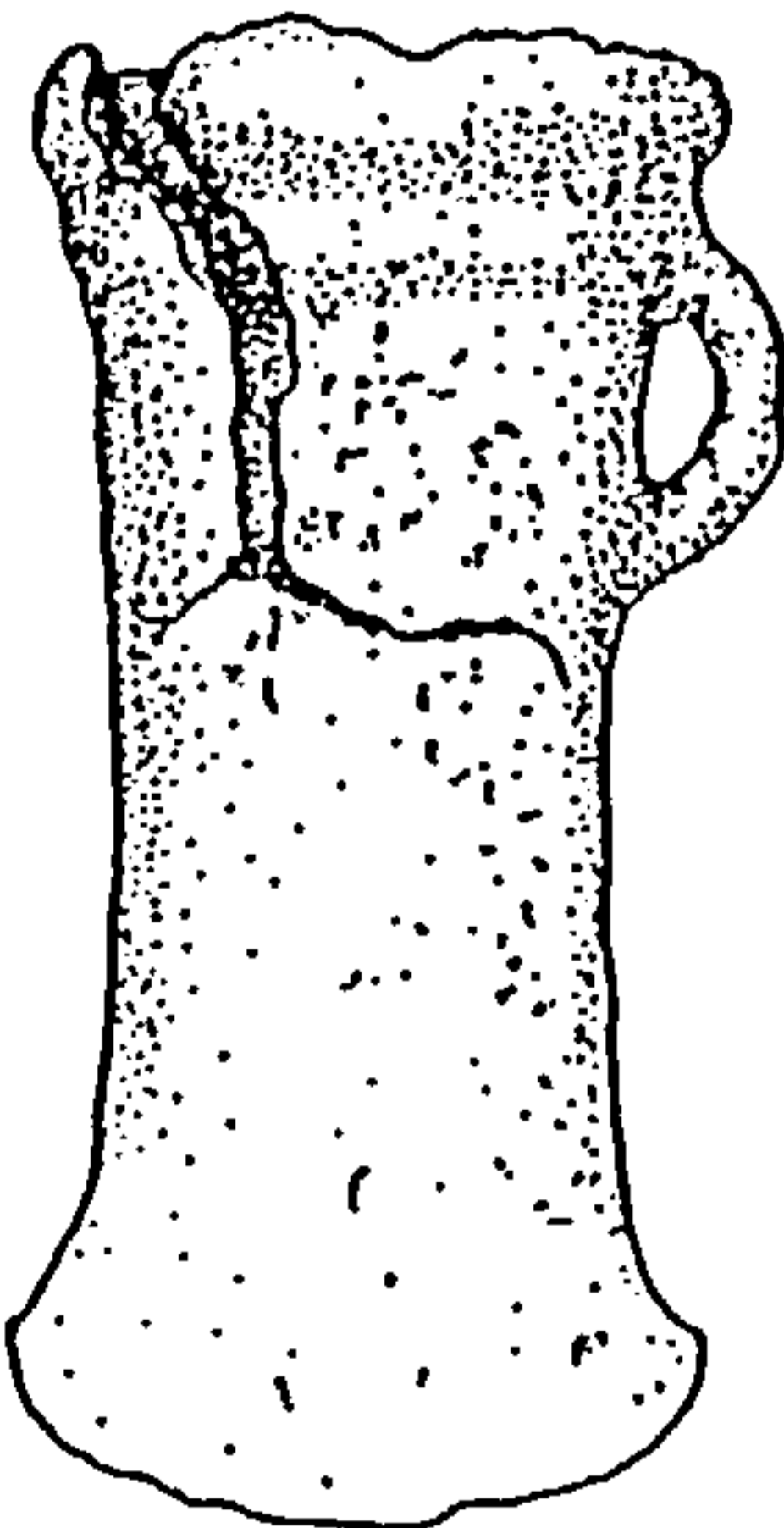
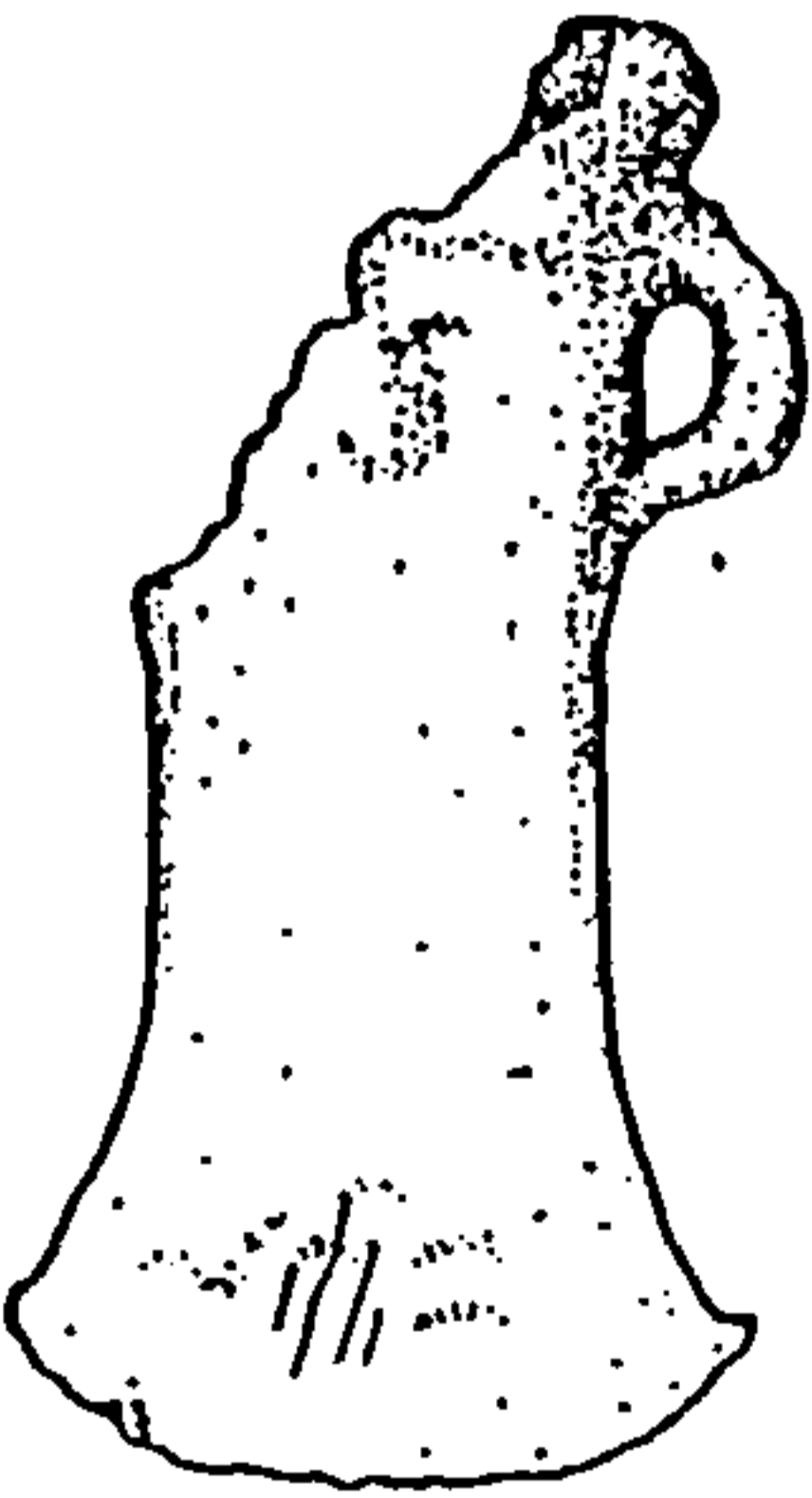
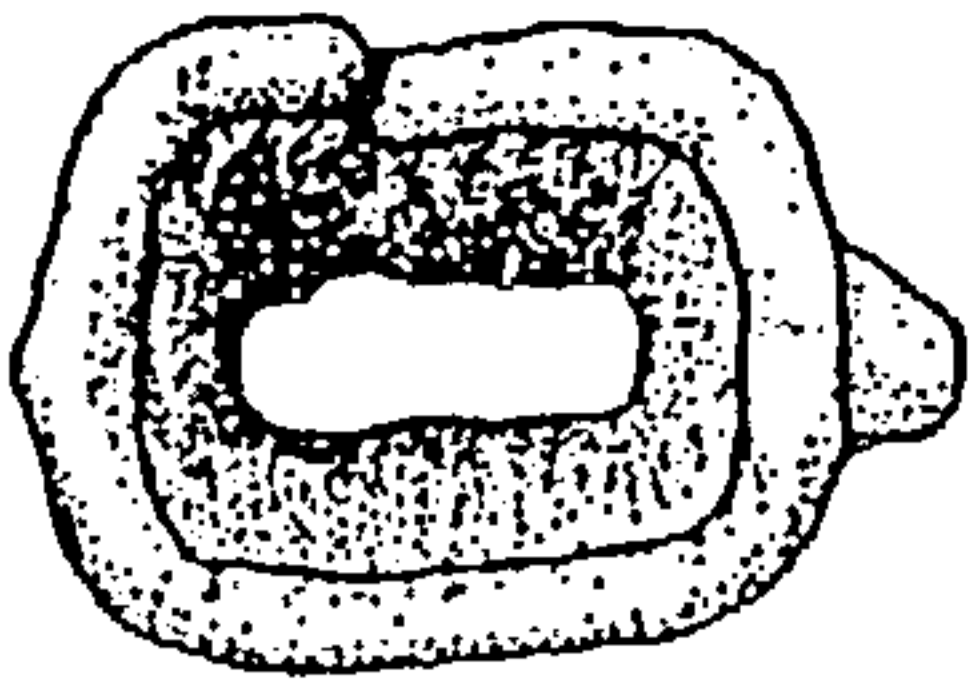
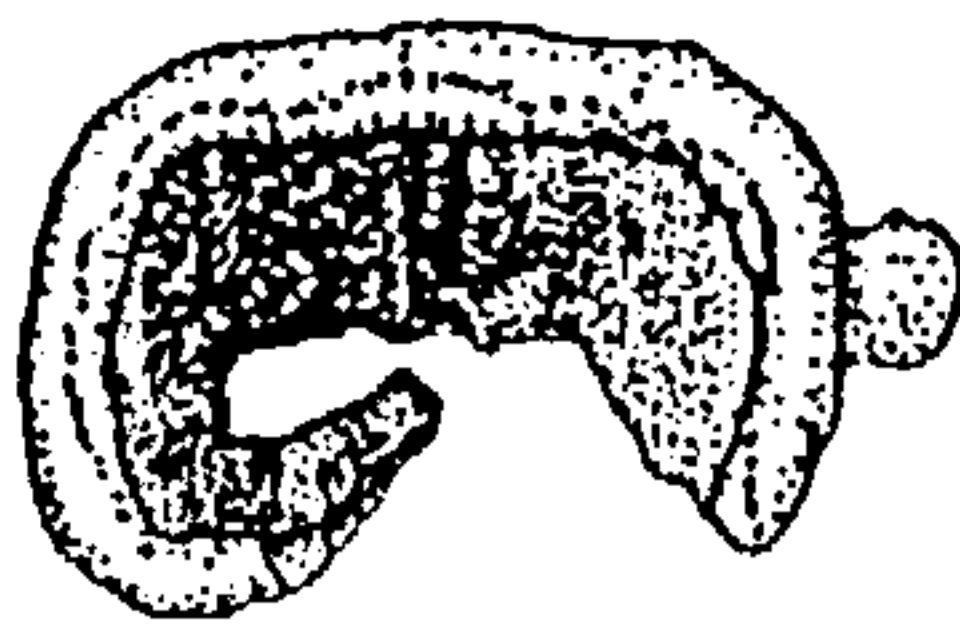


Fig. 8. The All Hallows II Hoard (Ref. No. 13): Socketed Axes

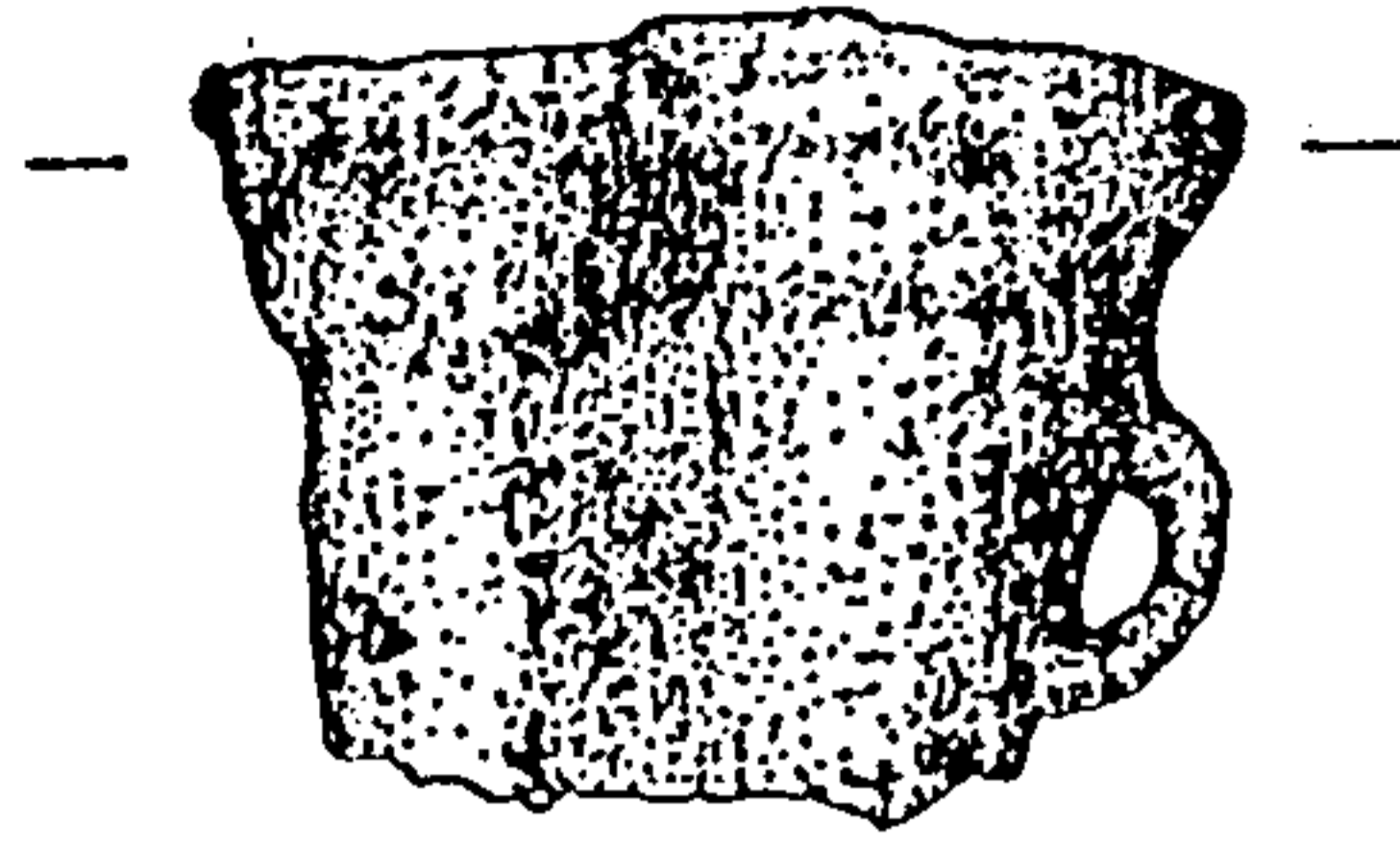
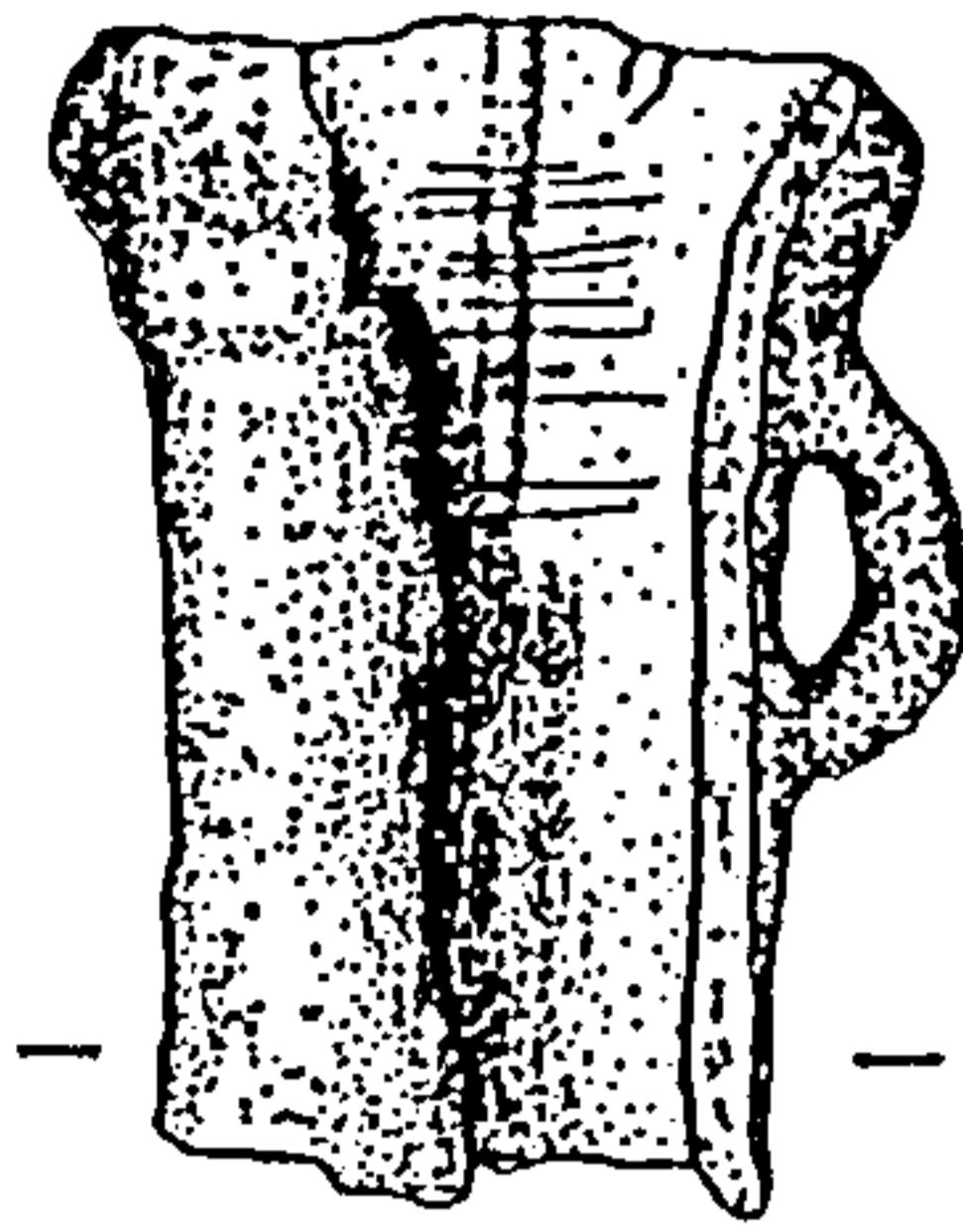
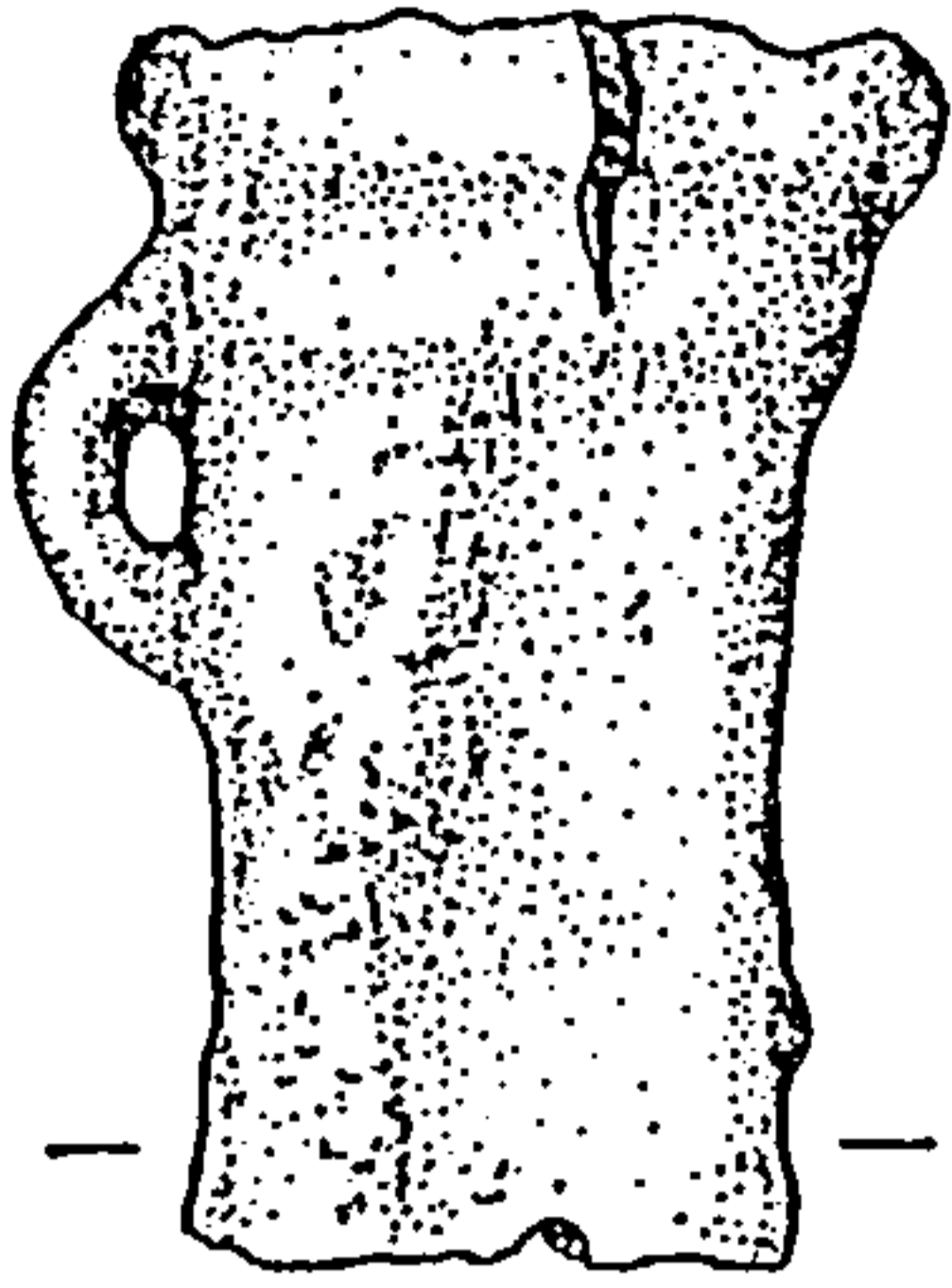
13/08



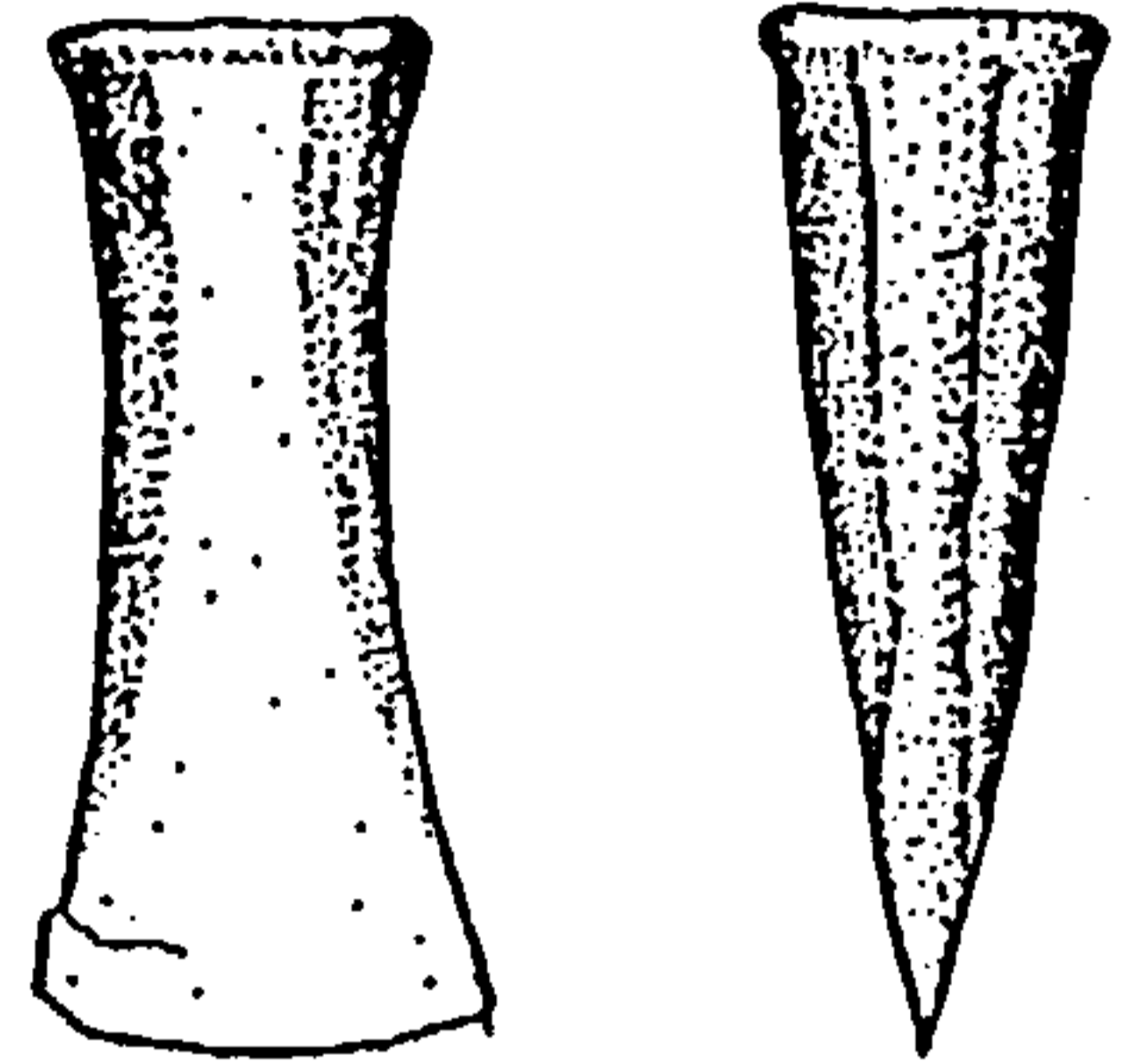
13/09



13/10



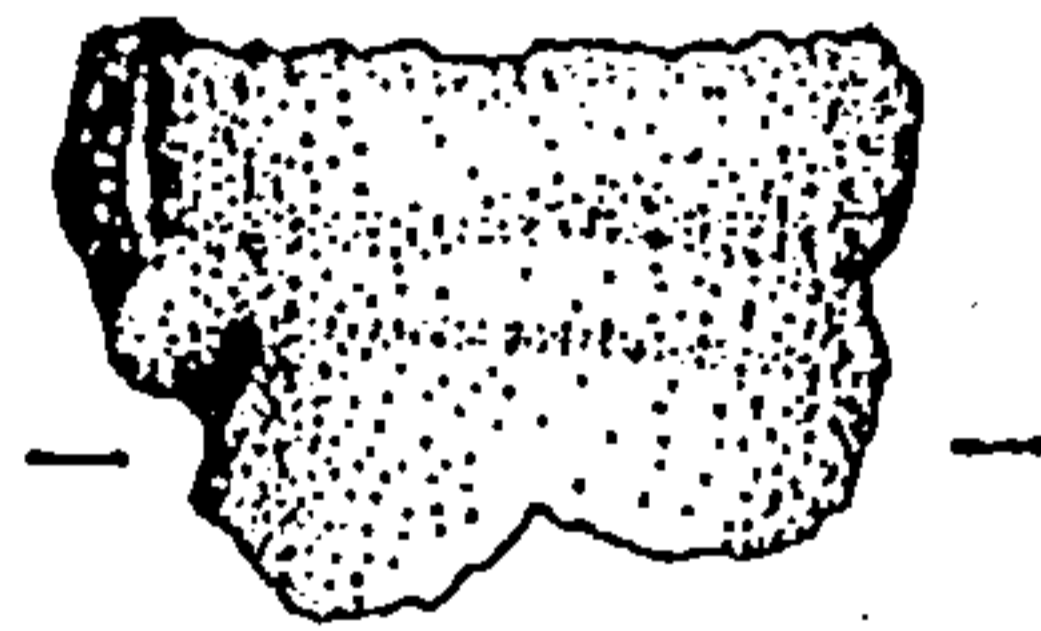
13/13



13/12

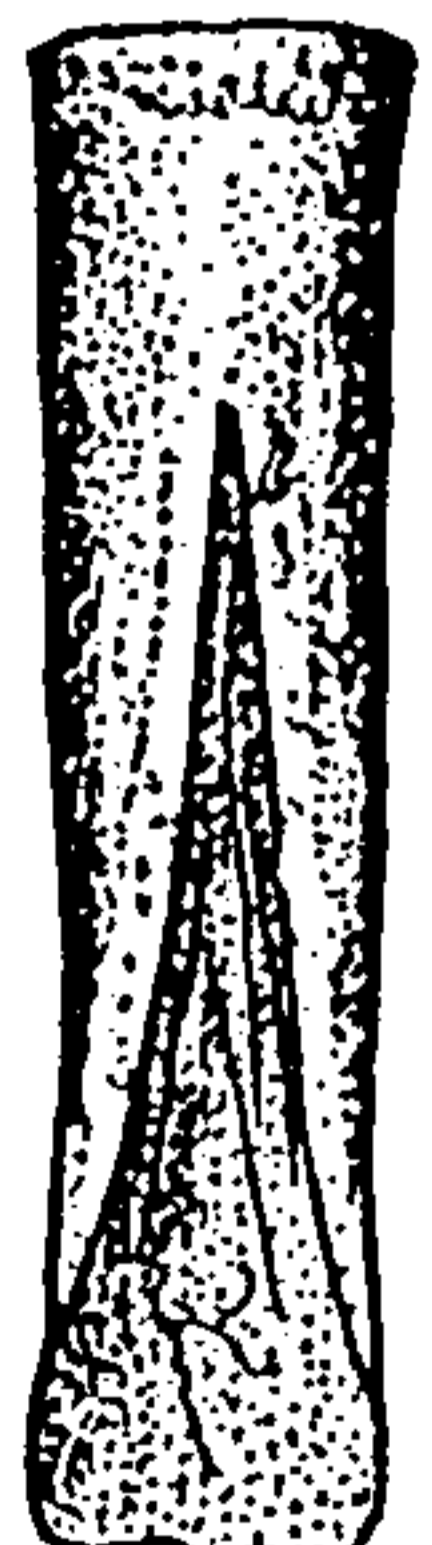
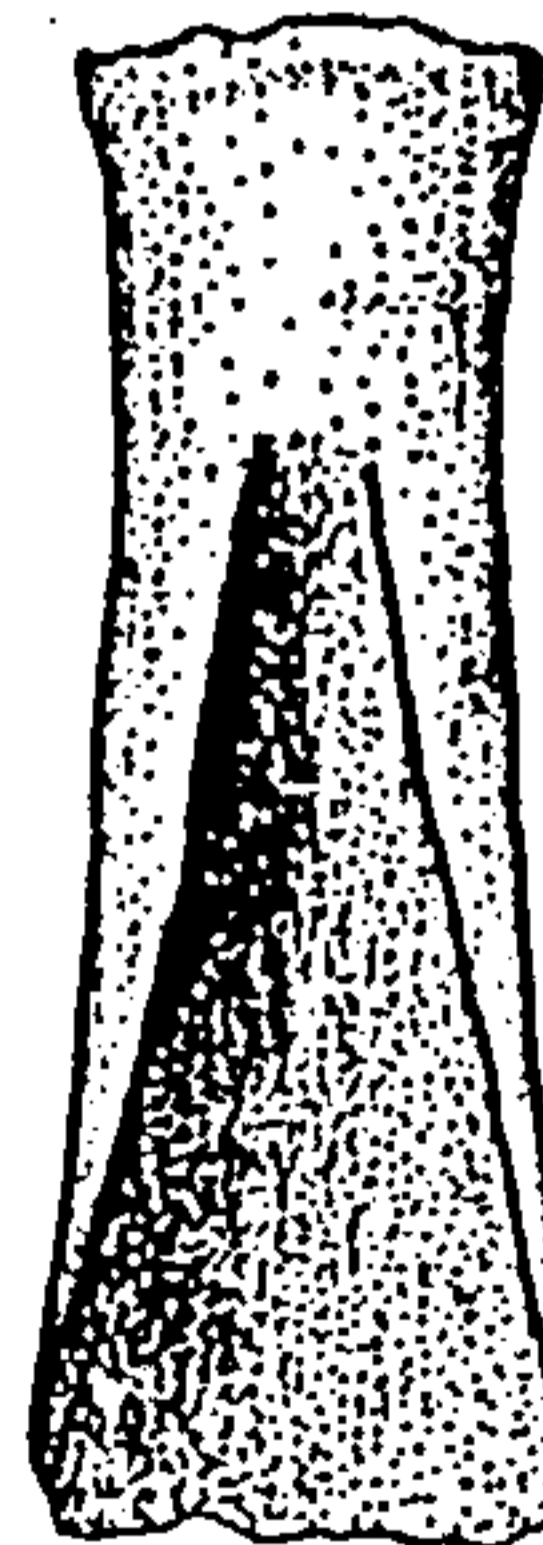
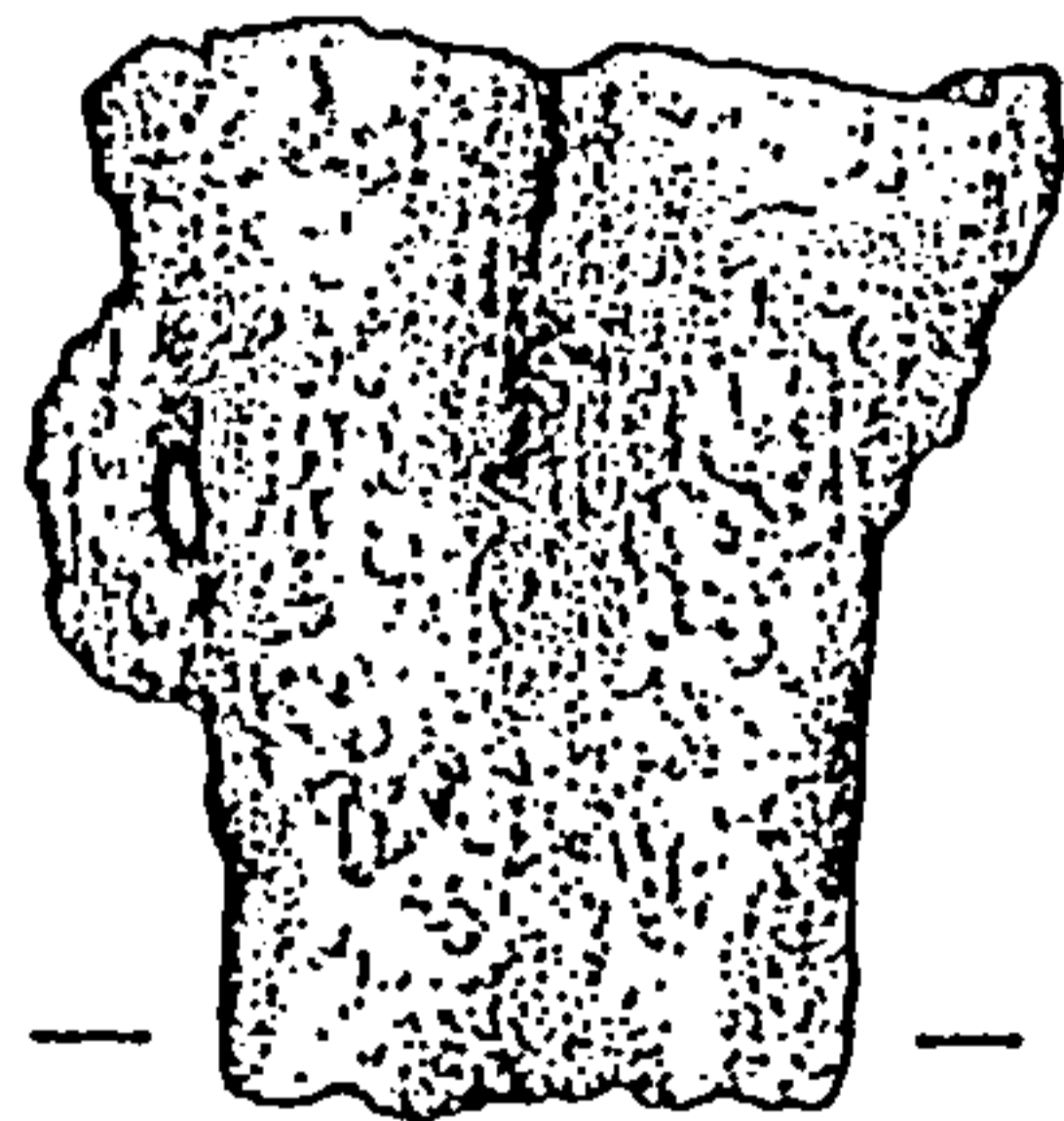


13/11



13/14

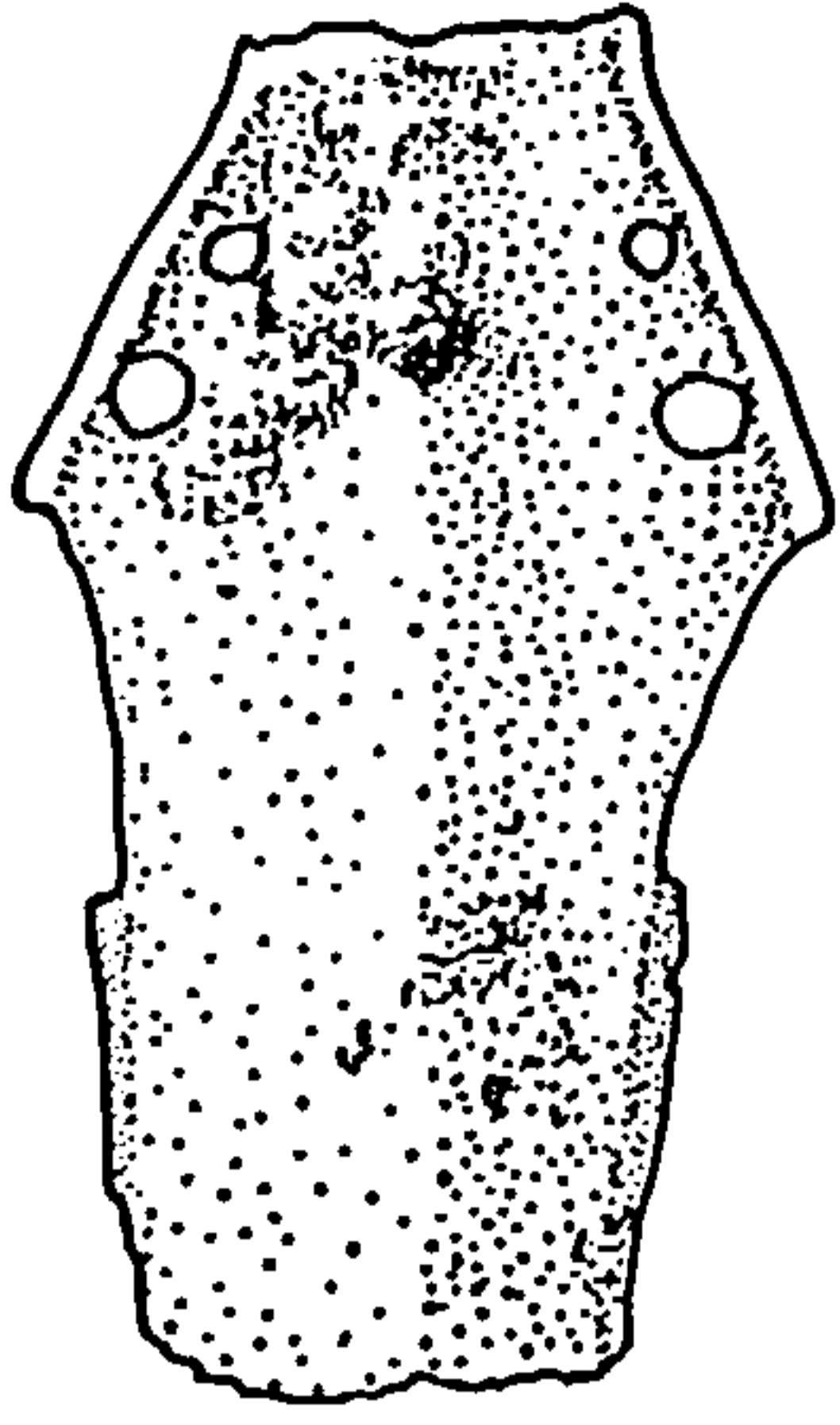
13/15



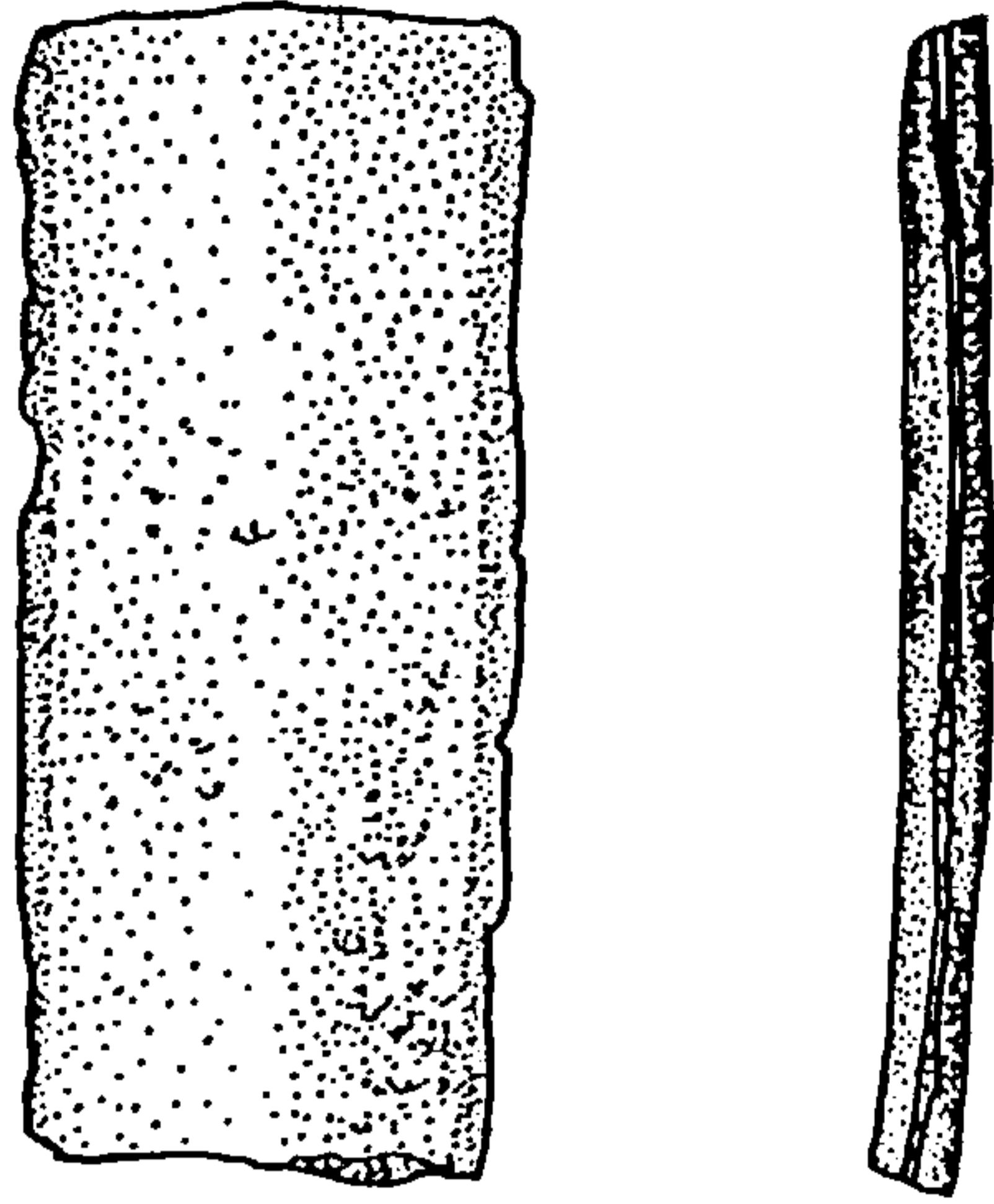
0 2cm

Fig. 9. The All Hallows II Hoard (Ref. No. 13): Socketed Axe Fragments and Small Tools

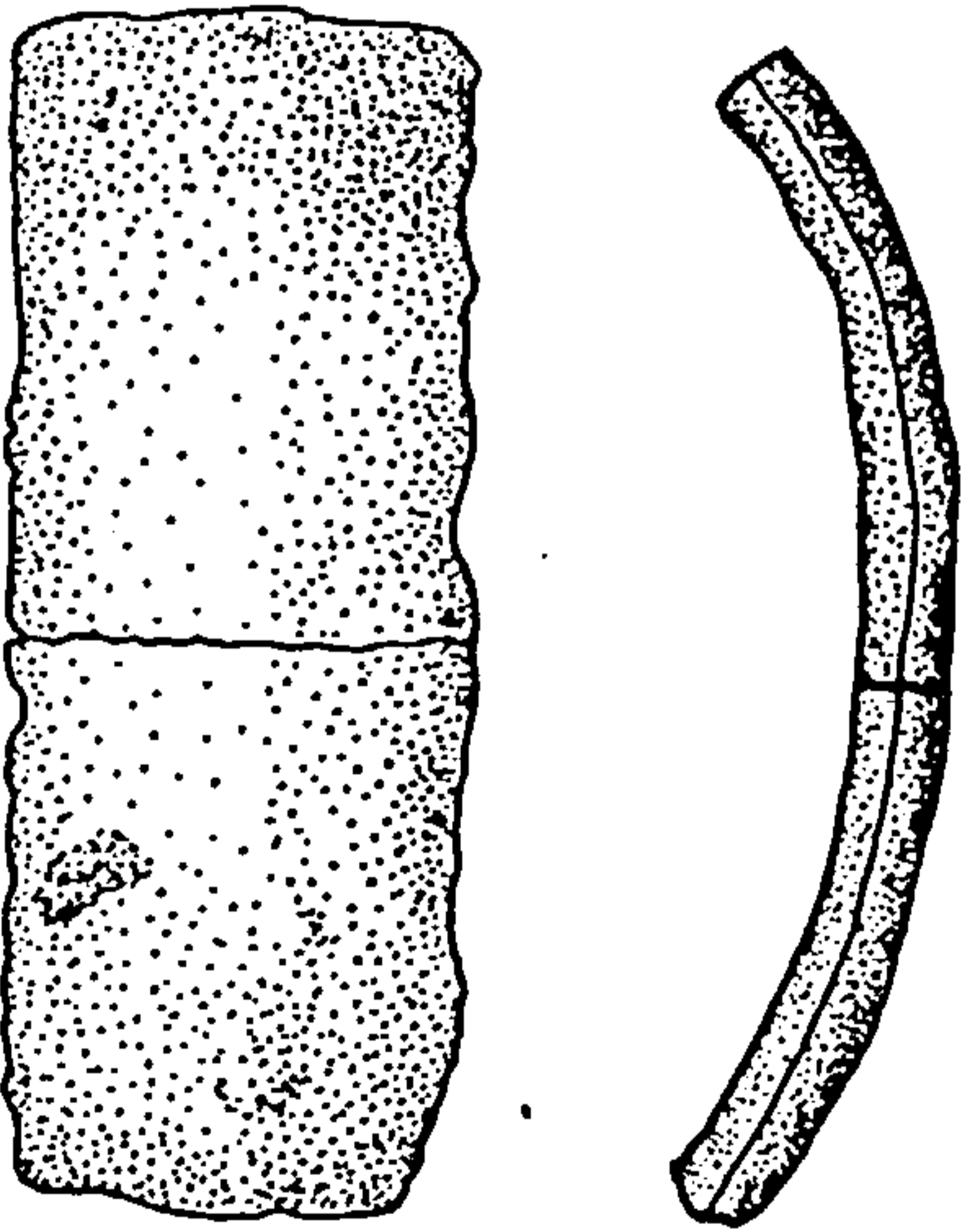
13/16



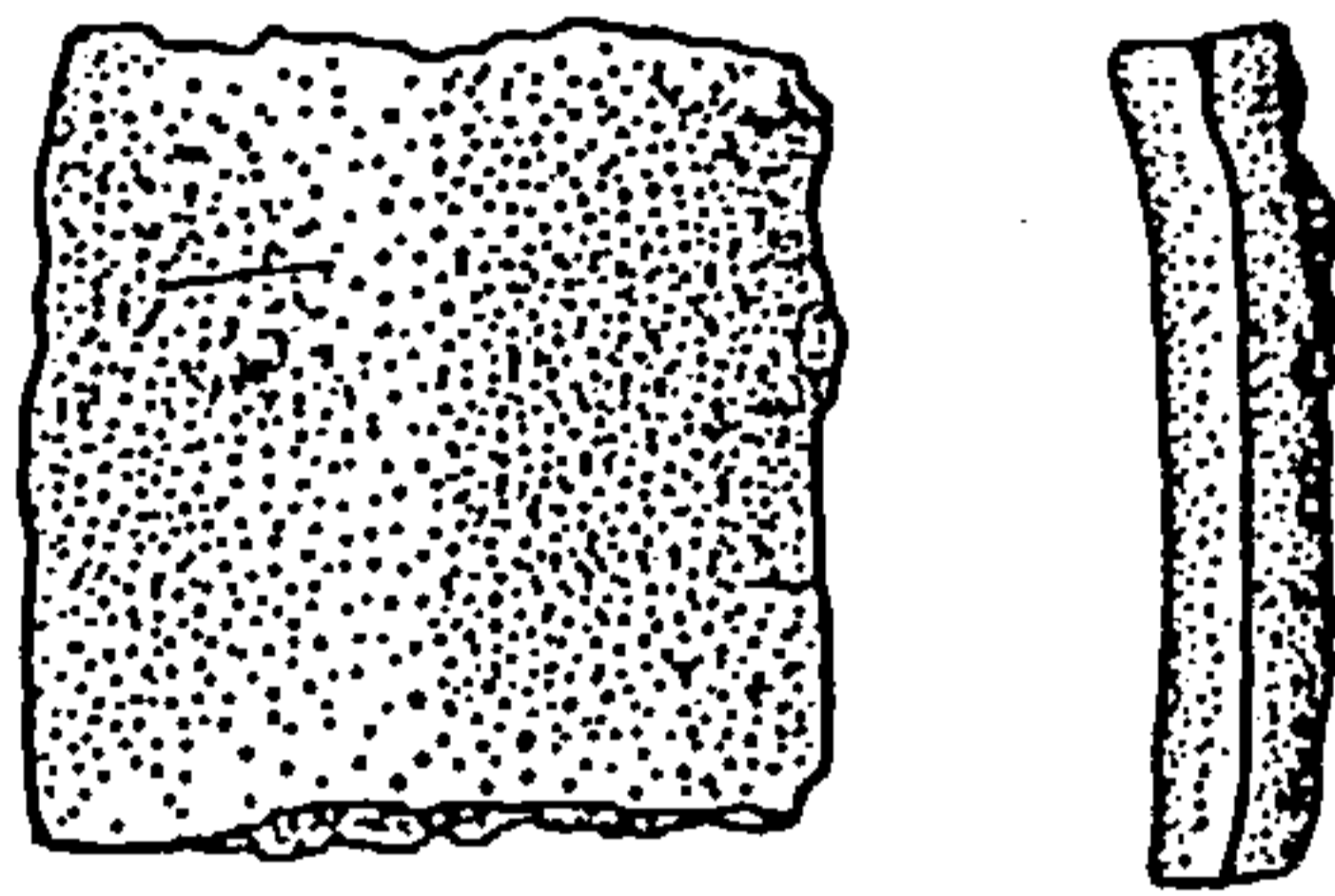
13/17



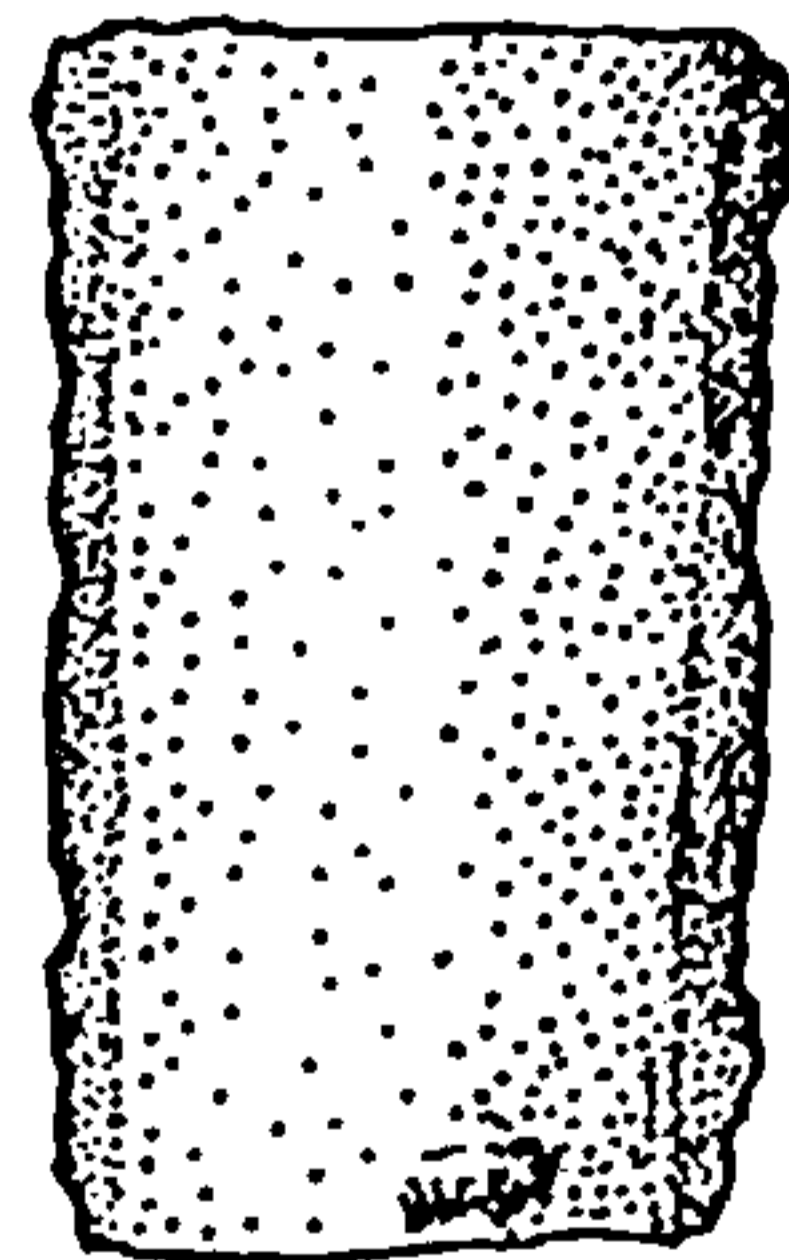
13/18



13/19



13/20

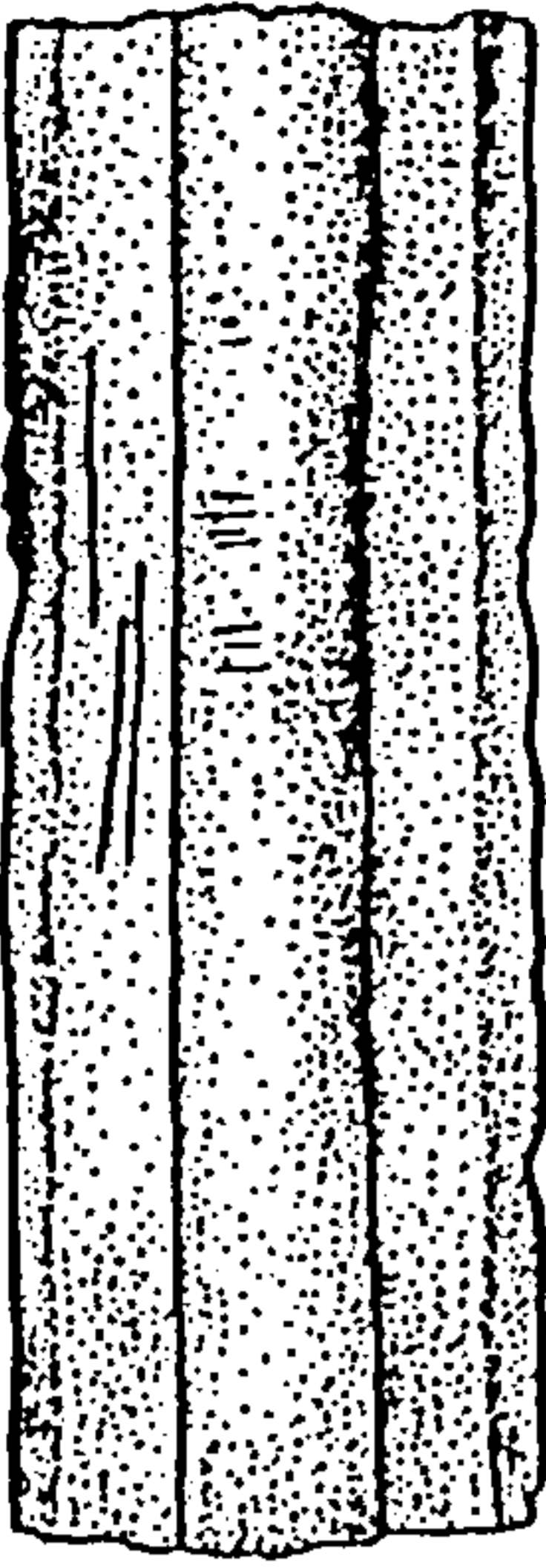


0 2cm

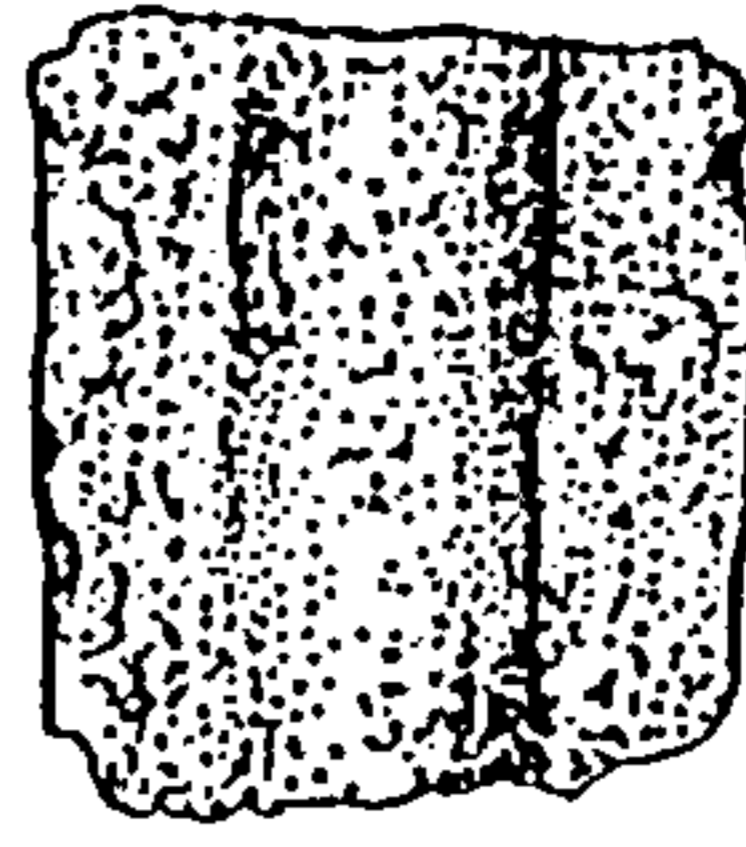
 A horizontal scale bar with a vertical tick at the left end labeled '0' and a vertical tick at the right end labeled '2cm'.

Fig. 10 The All Hallows II Hoard (Ref. No. 13): Sword Fragments

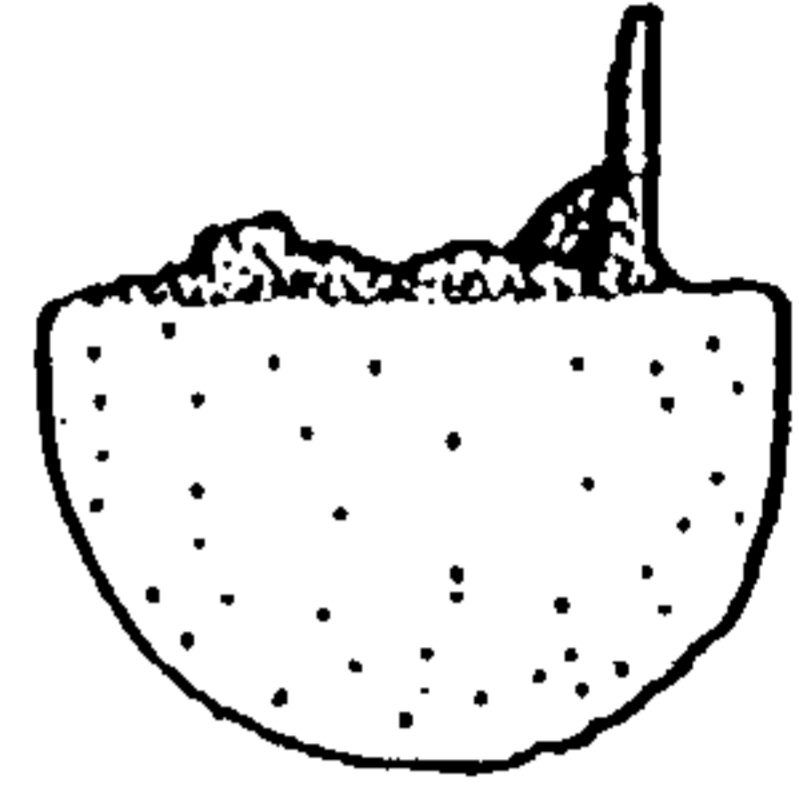
13/21



13/22



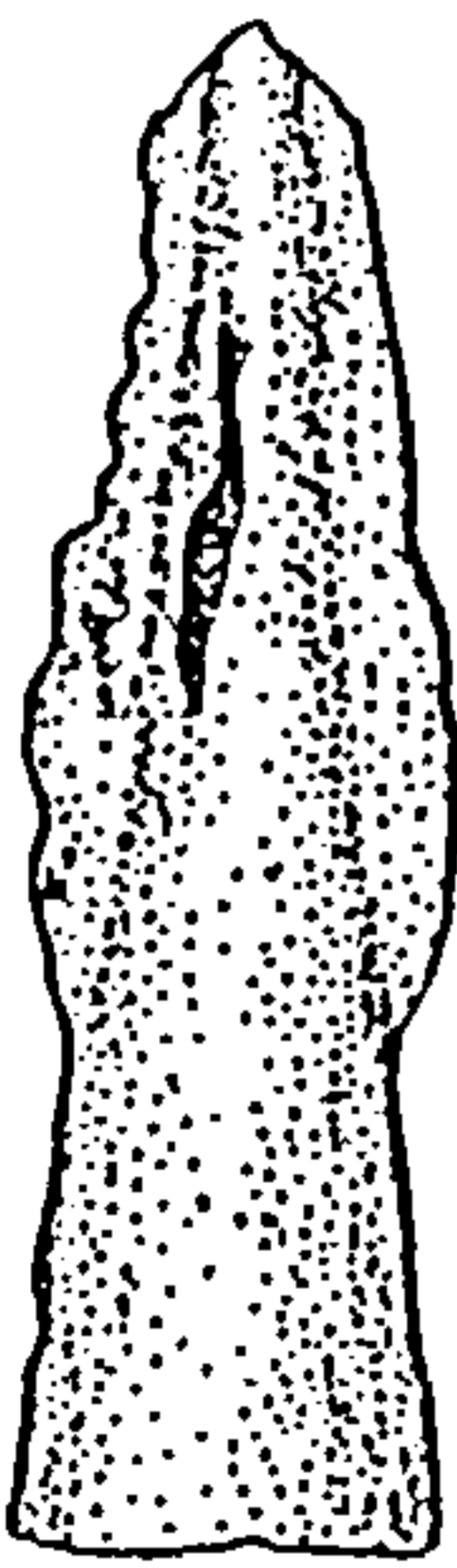
13/23



0 2cm



13/24



13/25

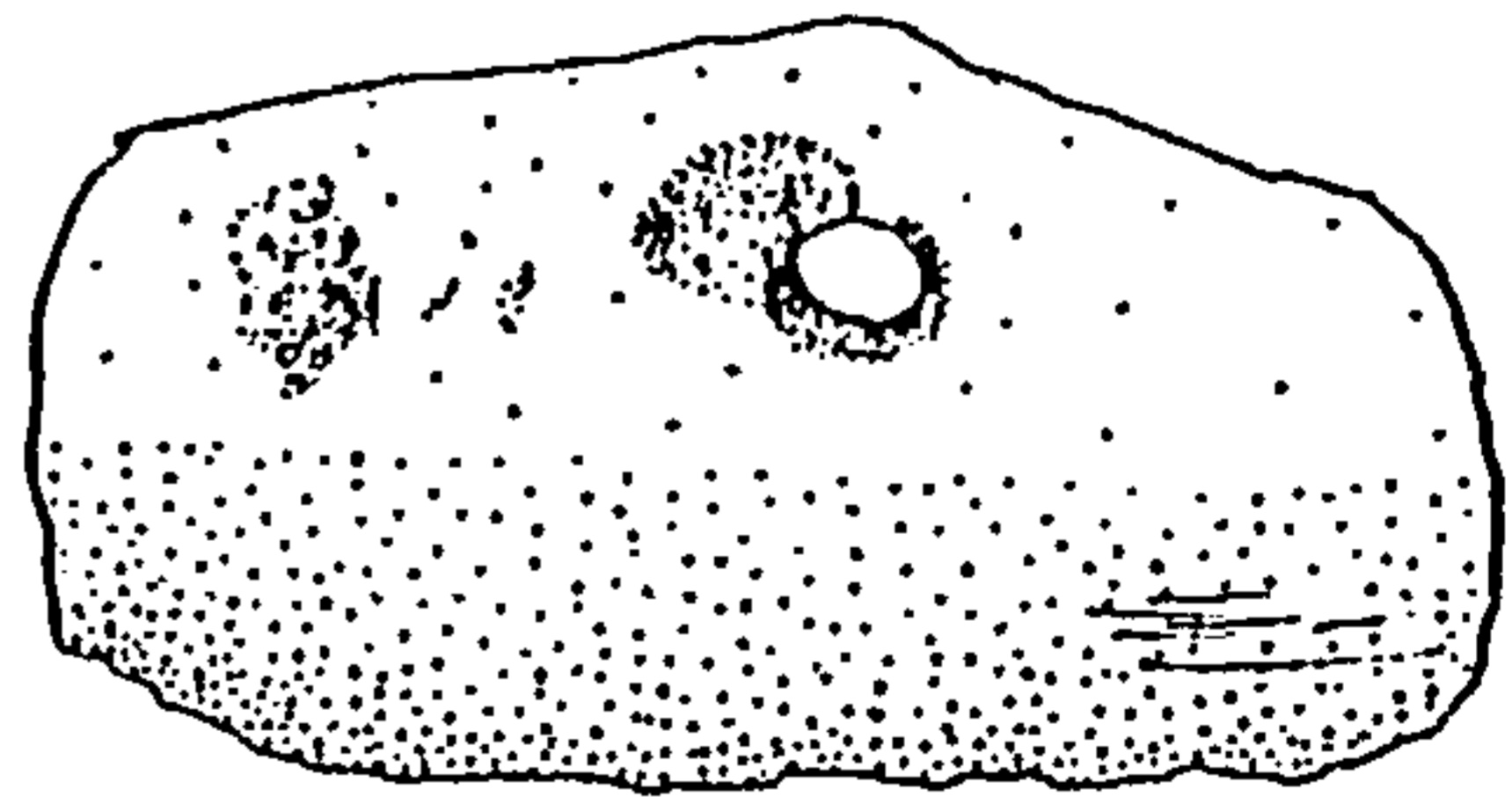


Fig. 11 The All Hallows II Hoard (Ref. No. 13): Weapons and Miscellaneous Items

Aylesford (Ref. No. 14)

Grid Reference: TQ 74 60.

Current Location: British Museum, W.G. 1944-7.

Context: A note stored with these objects reads 'Found at Preston Shelf at Aylesford, the ancient ford in a line of the pilgrim's road'. Another reference states that the axes were found 'in a sand drift in the line of the ancient road' (N.B.I.).

Bibliography: Jessup, 1931.

National Bronze Index (N. B. I.)

Contents:-

14/01 (Acc. No. W.G. 1944)

Description: Socketed axe, with 3 ribs on either face and a squared-off appearance to the collar. An unusual decorative feature is present on the lower surface. Here the loop merges with two ribs which diverge and run off towards either face. The axehead is rather massive in size, and is probably of one of the 'highland' types.

Dimensions: Length: 135mm. Cutting edge: 57mm. Weight: 462.8g.

Patina: Thick light green, details good.

Manufacture: The mouth has been well-finished. The casting seam remains visible here but it has been hammered flat, as if retained deliberately as a decorative feature. The uppermost casting seam can still be identified, but has been neatly finished. The lower seam is similar, but has been flattened over the loop. The blade is widely expanded, and there are coarse diagonal grinding marks visible over its extent on both faces.

Use: The cutting edge largely survives in reasonable condition, though there is a large notch missing from its centre.

Reduction: A series of sharp notches can be seen on the uppermost surface of the object. This damage may have been caused by striking the axehead with a heavy, sharp instrument, i.e. another axe.

14/02 (Acc. No. W.G. 1947)

Description: Socketed axe, with 3 unevenly spaced ribs on either face. On one face the ribs are quite closely clustered, while on the other, two are more closely spaced, while the third is displaced to the side. The axehead has a single collar moulding with a squared-off appearance, and is probably of a 'highland' type, e.g. Yorkshire.

Dimensions: Length: 86mm. Cutting edge: 52mm. Weight: 189.2g.

Patina: An olive outer layer has flaked away to reveal a pale green surface. Details poor.

Manufacture: The mouth seems uneven, indicating that an inadequate supply of metal was used during casting. The feeders and the intervening casting seam have been obliterated from the mouth, leaving a flat surface. The uppermost seam has been hammered and flattened, leaving only a vestigial trace. The lower seam is similar, but remains more prominent over the loop and the collar. The blade is widely expanded, and some horizontal grinding marks are visible over the cutting edge on one face (not illustrated).

Use: The cutting edge is notched, and this damage appears to have taken place in antiquity. The crack running down from the mouth may be use-related, though it may be related to the reduction process.

Reduction: No evidence can clearly be linked with this process, though it is possible that the large crack which runs down one face resulted from this process, i.e. during the hammering which was required to separate axehead and haft.

14/03 (Acc. No. W.G. 1945)

Description: Socketed axe of faceted type.

Dimensions: Length: 105mm. Cutting edge: 49mm. Weight: 227.7g.

Patina: Rough olive-green with encrustation over the base of the blade. Details poor.

Manufacture: The mouth has been extremely well-finished, with no traces of the feeders or the intervening seam surviving. Faint traces of the uppermost seam can be identified over the upper body, but below this point the seam has been obliterated. The situation is

similar on the lower surface. Here the seam has been flattened and smoothed, but in this example it remains very thick and heavy over the loop. On one face, there are some coarse diagonal grinding marks apparent on the cutting edge (not illustrated). The blade is crescentic in shape and was probably resharpened.

Use: The cutting edge is badly burred and notched over its length, with one substantial notch missing from one corner.

Reduction: Some sharp notches can be identified on the uppermost surface of the piece. These are similar in appearance to those on 14/02, and may also be evidence of damage inflicted by another axe, though they are not so clearly apparent in this example.

14/04 (W.G. 1946)

Description: Socketed axe of unusual faceted type. In this example, the facets upon either face are defined by ribs.

Dimensions: Length: 101mm. Cutting edge 47mm.

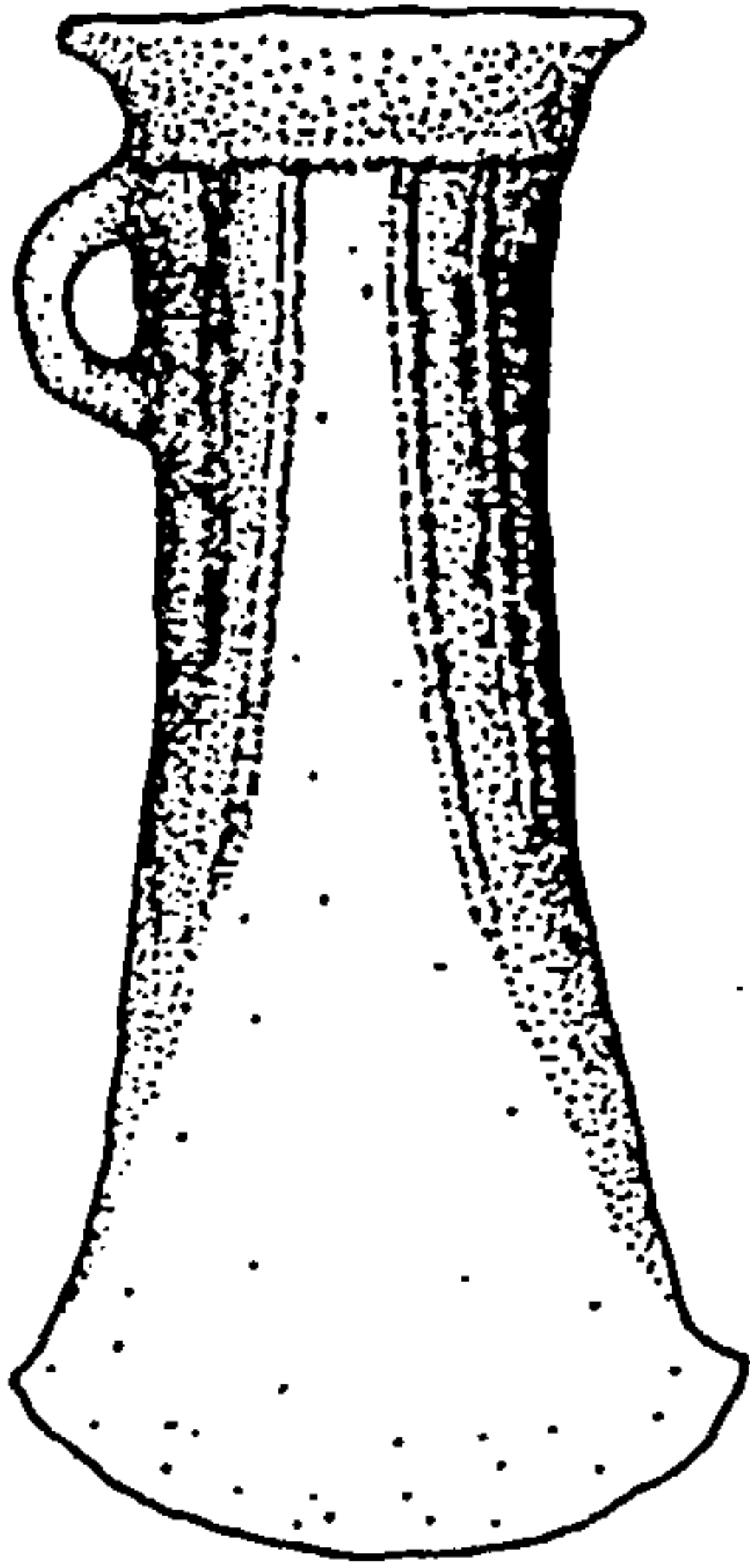
Patina: Rough light green, details poor.

Manufacture: The mouth has been well-finished, with no traces of the feeders or the intervening casting seam surviving. Elsewhere, the casting seams have been subject to careful finishing, with only vestigial traces surviving over their extent. The blade has been well-expanded, and is virtually crescentic in shape, which suggests that it was resharpened, perhaps on more than one occasion.

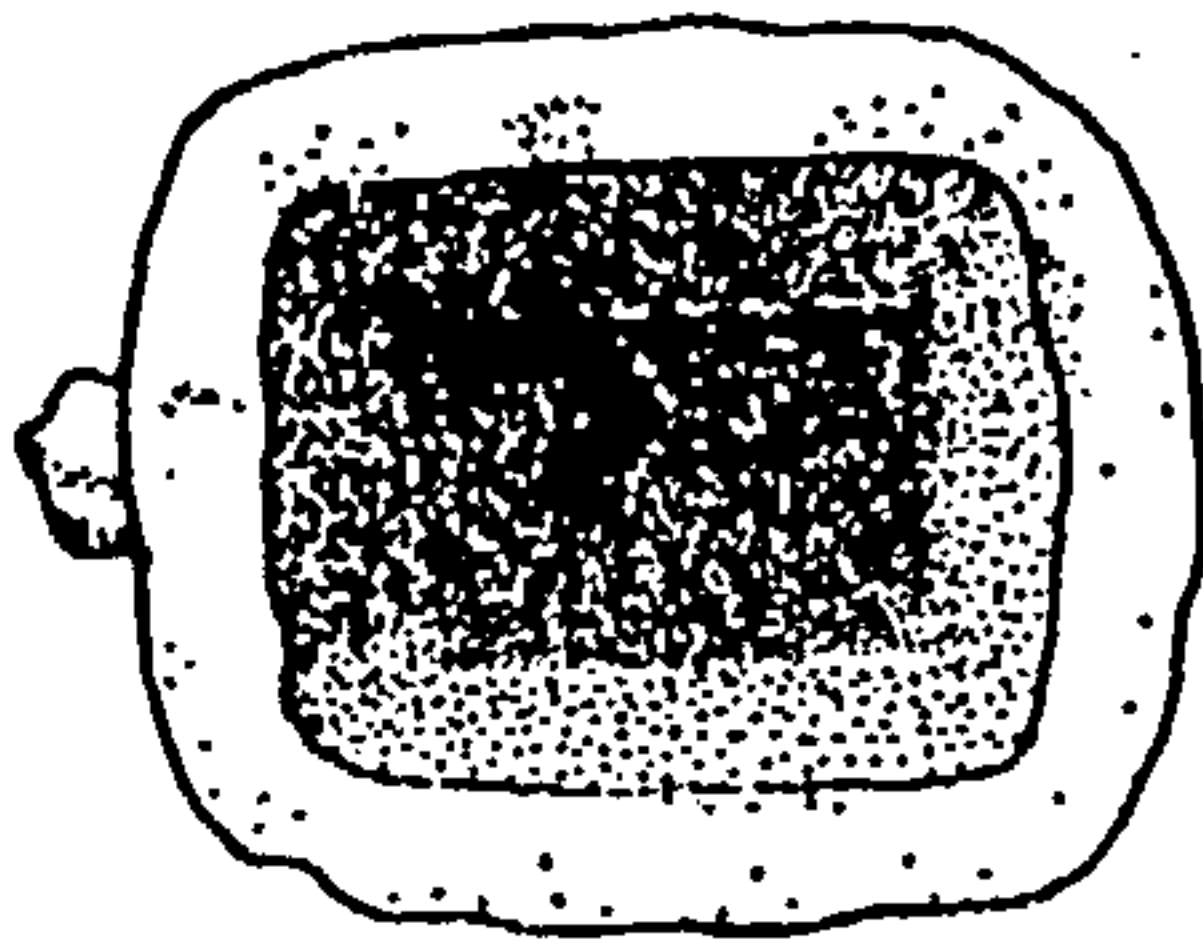
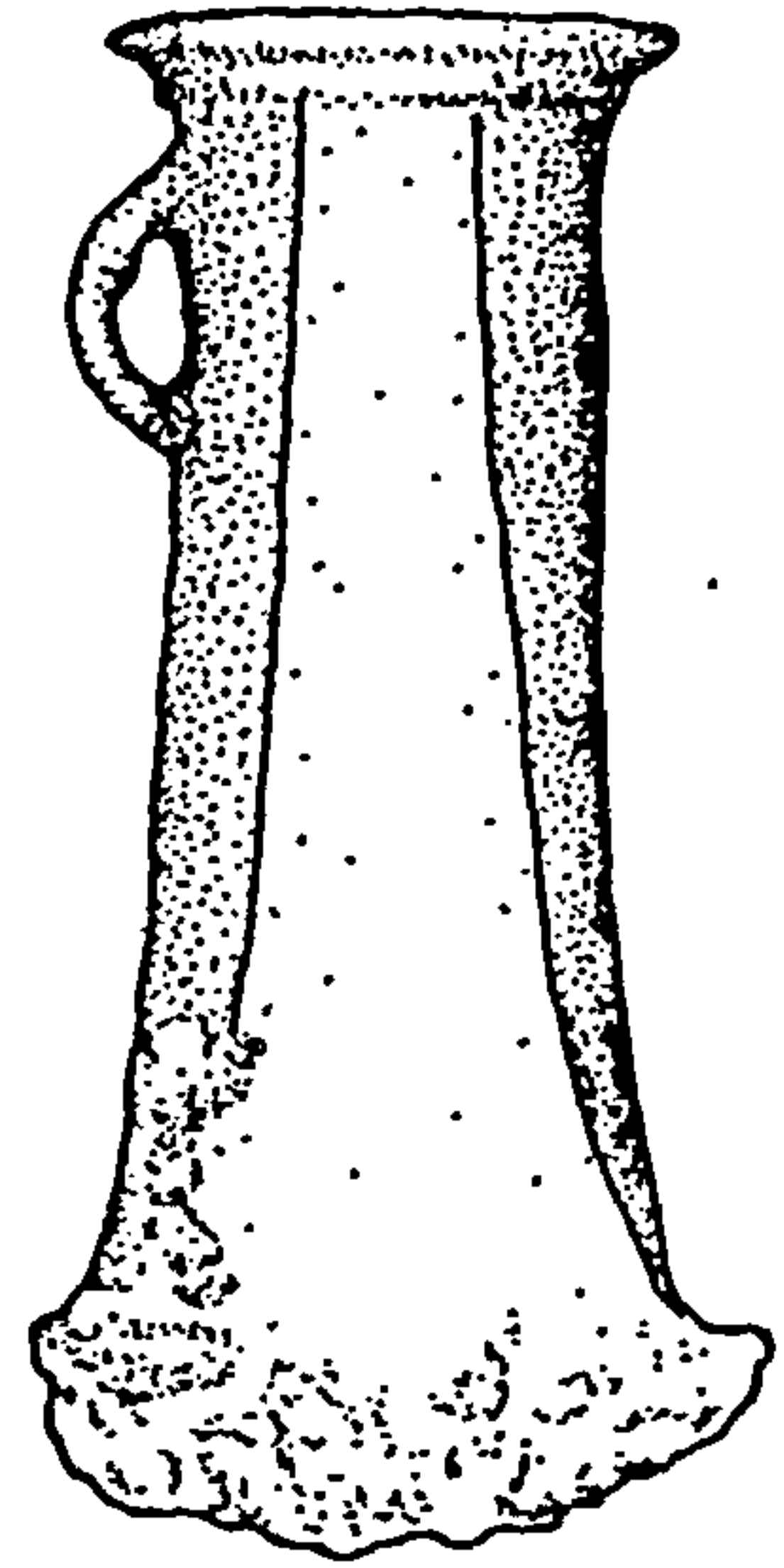
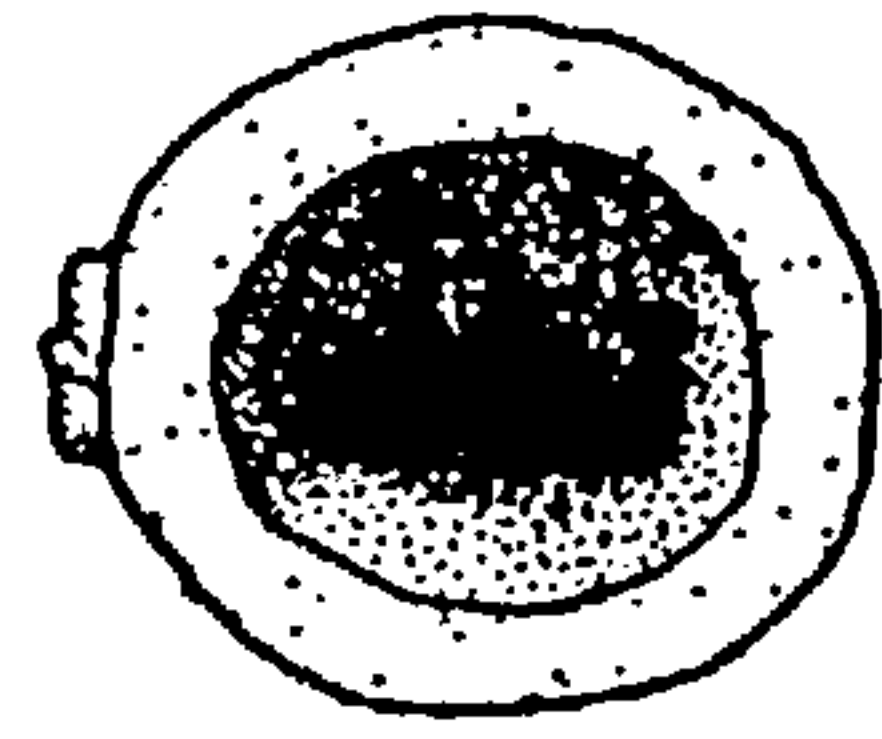
Use: The cutting edge remains in reasonable condition, though it is slightly chipped over its extent.

Reduction: There is no evidence relating to this process.

14/01



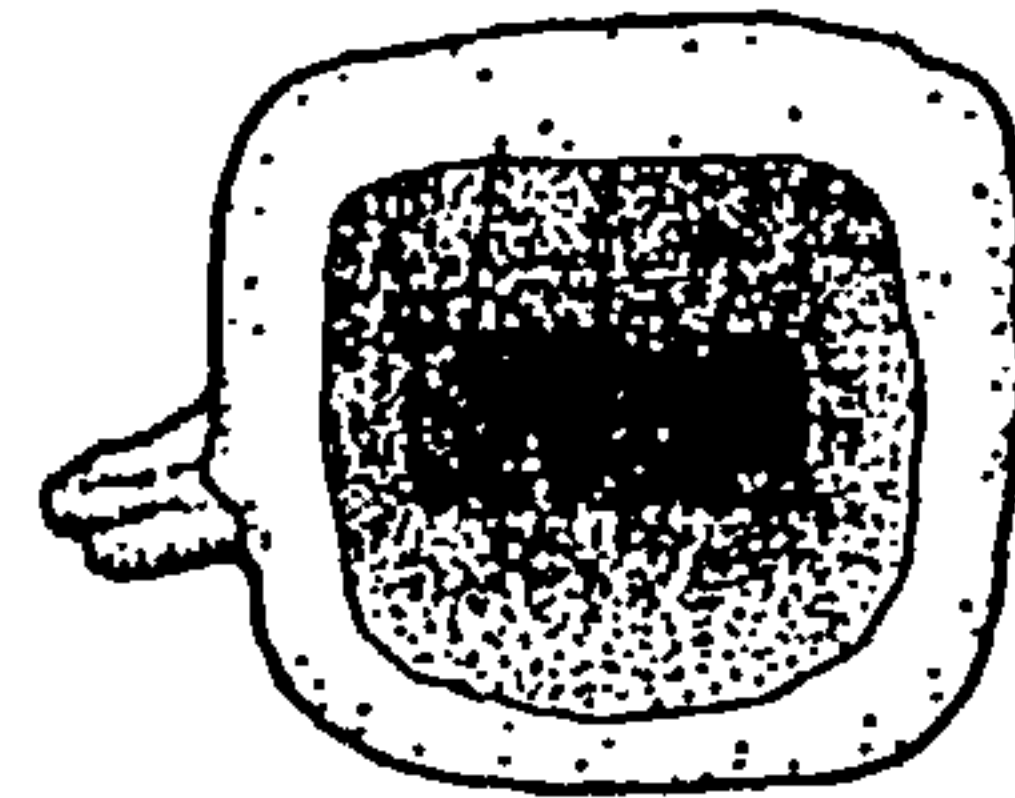
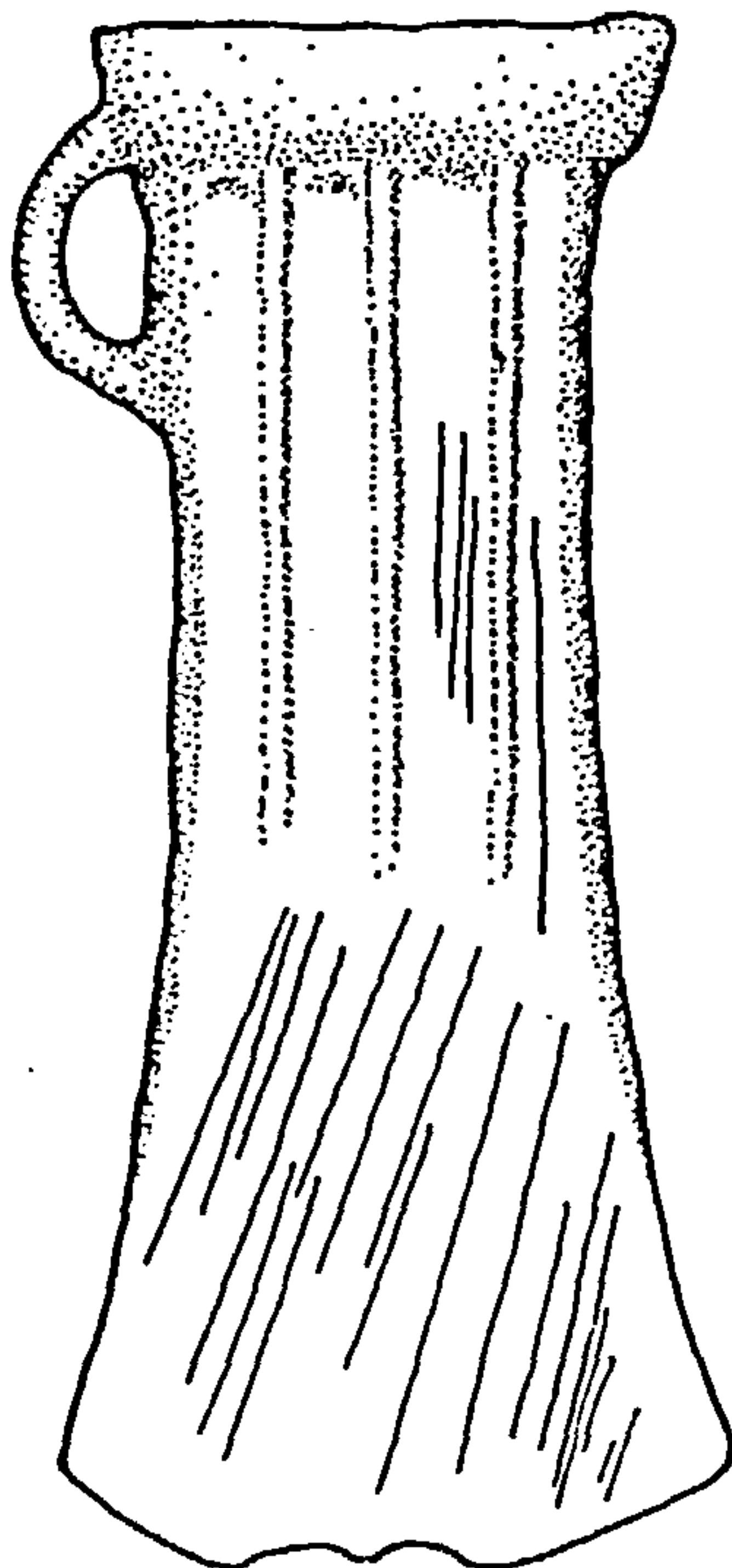
14/02



0 2cm

 A horizontal scale bar with a vertical tick at the left end labeled '0' and a vertical tick at the right end labeled '2cm'.

14/03



14/04

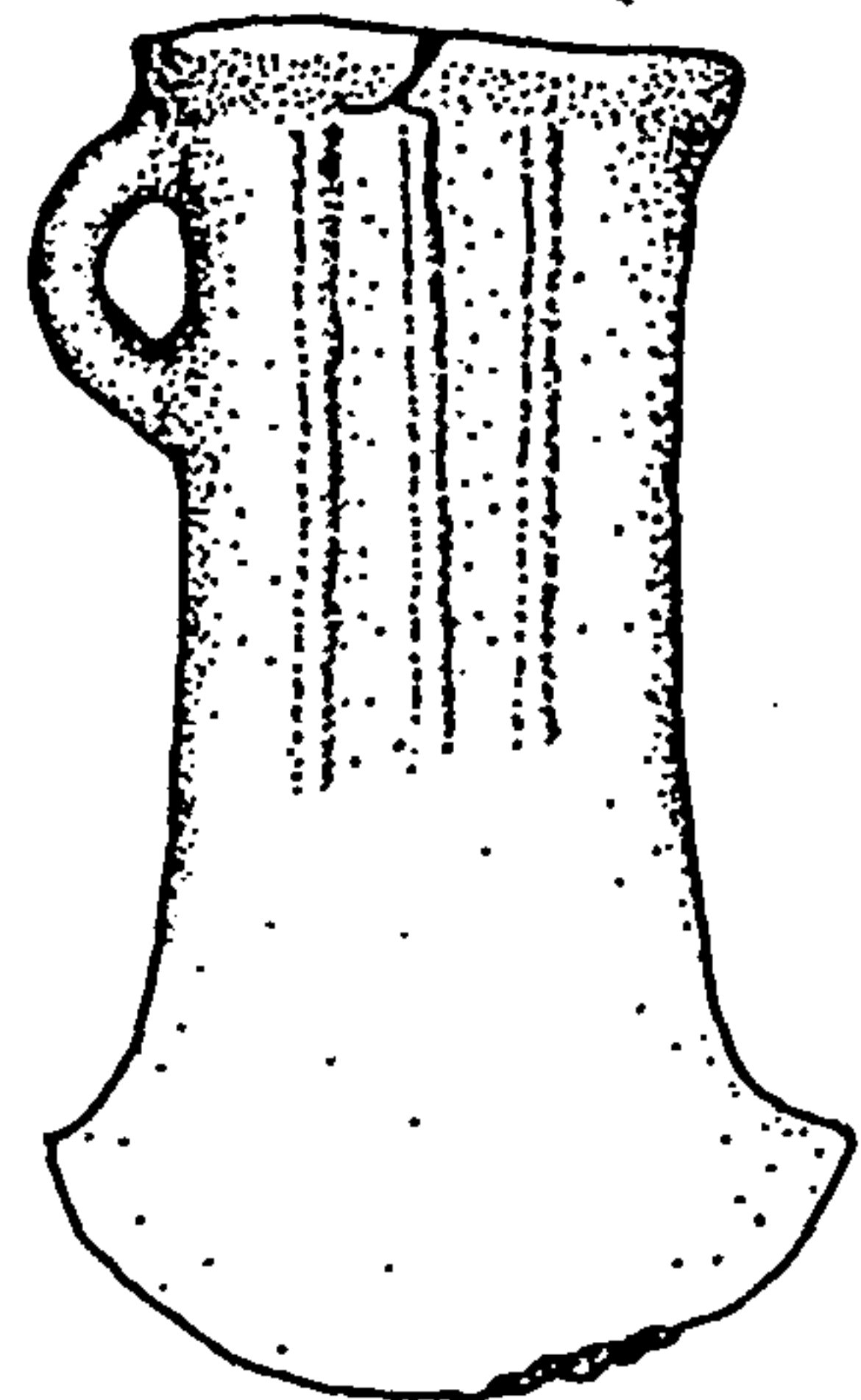


Fig. 12 The Aylesford Hoard (Ref. No. 14)

Bexley Heath (Ref. No. 15)

Grid Reference: TQ 499 743.

Current Location: British Museum.

Context: Found in a sandpit, at a depth of 15-20 feet.

Bibliography: Burgess and Colquhoun, 1988.

Kendrick and Hawkes, 1931.

Britton, 1959 (Inventaria Archaeologia, G.B. 53-3).

National Bronze Index.

Tester, 1957.

Contents:-

15/01 (Acc. No. 1931: 3-14: 9)

Description: Socketed axe, of 'south-eastern' type, with four ribs on either face. The outermost ribs define the line of interface between the faces and the upper and lower surfaces.

Dimensions: Length: 73mm. Cutting edge: 45mm. Weight: 148.6g

Patina: Rough dark green, details somewhat obscured.

Manufacture: The stump of a feeder remains visible on the mouth, and there are traces of a seam remaining here, too. The top seam is smooth but prominent right down to the cutting edge. On the underside, the situation is similar, but the seam has been flattened more extensively over the loop. The cutting edge is crescentic in shape, and there is a faint bevel evident on one side (not illustrated).

Use: The edge appears blunt and chipped over much of its length.

Reduction: Chisel marks are visible in the vicinity of the collar, and one isolated small tool mark can be seen lower down the blade. These marks are probably linked with the removal of the axehead from its haft.

15/02 (Acc. No. 1931: 3-14: 3)

Description: Socketed axe, of 'south-eastern' type, with three ribs on either face.

Dimensions: Length: 96mm. Cutting edge: 45mm. Weight: 282.8g.

Patina: Rough mid-green, details obscured.

Manufacture: The metal appears pitted in places, with a hole evident in the casting between the collar mouldings. The vestige of a feeder survives on one side of the mouth. The upper seam is still apparent over much of the object, but has been virtually obliterated on the lower third of the piece towards the blade. On the underside, the seam is almost invisible below the loop, but is smooth and prominent elsewhere, including over the loop. The cutting edge is well-expanded, and is virtually crescentic in shape.

Use: The edge is in poor condition, with none of the original edge surviving and substantial notches missing at one end.

Reduction: Some possible chisel marks are visible on the upper collar, damage which probably resulted from the removal of the axehead from its haft.

15/03 (Acc. No. 1931: 3-14: 16)

Description: Socketed axe, of 'south-eastern' type, with four faint furrows just visible on one face. The other face appears to be undecorated.

Dimensions: Length: 88mm. Cutting edge: 54mm.

Patina: Rough pale-green, with some bronze showing. Details locally good.

Manufacture: Some vestiges of the seam remain around the mouth, which appears uneven in places. The top seam seems to have been trimmed, but remains sharp right down to c.10mm from the cutting edge. The lower seam is similar, but is flattened over the loop. Horizontal grinding marks are visible over the cutting edge in places. The cutting edge is markedly crescentic, with a faint bevel running along it, and tiny vertical grinding marks can be seen running back from the edge.

Use: The blade is unevenly worn. It remains sharp and fine over roughly half of its length, while the rest is chipped, with one substantial notch broken away.

Reduction: The object is complete, with no visible evidence relating to this process.

15/04 (Acc. No. 1931: 3-6: 14D)

Description: Socketed axe, of 'south-eastern' type, with traces of two, or perhaps three, ribs apparent near the lower moulding. This decoration is only apparent for a few millimetres beneath the collar mouldings. Two internal ribs are present.

Dimensions: Length: 96mm. Cutting edge: 47mm. Weight: 210.6g.

Patina: Rough mid-green/olive, details locally reasonable.

Manufacture: The mouth is very messy, with the stump of a feeder remaining on one side. The other side has an uneven appearance, the result of an inadequate supply of metal during casting. The upper seam is thin and sharp, and apparent over the upper two-thirds of the object's length, and the underside is similar, though the seam has been flattened over the loop. There are some horizontal and diagonal grinding marks evident above the cutting edge, and there are indications of diagonal grinding marks on the edge itself, which is crescentic in appearance.

Use: The blade seems to be unevenly worn. It is battered and chipped over its length, though this damage may be exaggerated by flaking corrosion product. None of the original edge now remains.

Reduction: The object is complete, with no evidence relating to this process.

15/05 (Acc. No. 1931: 3-6: 1)

Description: Socketed axe, of 'south-eastern' type, with three collar mouldings. There are two indentations on either face, each of which resemble a shape that lies halfway between a wing and rib. There is a slight stepped appearance to the section between the upper and the lower body.

Dimensions: Length: 118mm. Cutting edge: 54mm. Weight: 413.4g.

Patina: Thick bright green, details faint but reasonable.

Manufacture: There is a marked dip in the mouth apparent at the point where the two mould valves joined (fig. 3). While one half seems like a good casting, the other shows evidence of the metal having flowed poorly. There are some traces of feeders and a seam still visible around the mouth. Elsewhere, the seams are trimmed but remain prominent over two-thirds of the piece, though the seam has been flattened over the loop. Horizontal grinding marks run across the blade, and vertical grinding marks are present along its length, too. Grinding marks can also be seen within the indented decoration, too. There are possible traces of fine hammering evident below the heavier upper section, and the cutting edge is crescentic.

Use: The edge is very battered in appearance, and has been unevenly worn. The blade seems to have been resharpened.

Reduction: There are small tool marks evident on the upper body, and some possible notches around the mouth. This damage is probably associated with the removal of the haft.

15/06 (Acc. No. 1956: 11-2: 6)

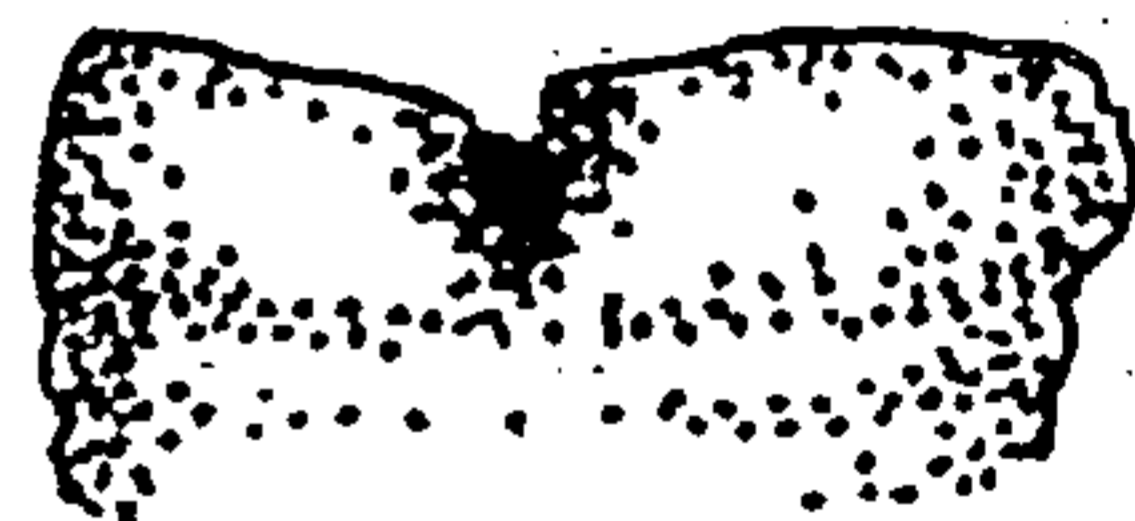
Description: Socketed axe of 'south-eastern' type, bearing three collar mouldings, and a variant on the wing-decorated theme, with two furrows as opposed to ribs on either face.

Dimensions: Length: 114mm. Cutting edge: 46mm. Weight: 293.8g.

Patina: Very rough mid-green. Some detail is visible towards the blade on one face, but elsewhere it is obscured.

Manufacture: The mouth seems uneven, with dips on both sides, the result of an inadequate supply of metal during casting. A feeder remains visible on one side of the mouth. The top seam has been flattened, but remains thick and clearly visible for two-thirds of the way down the piece, and the lower seam is similar, though it has been virtually obliterated over the loop. The blade is deep and crescentic in appearance, but is unusually narrow in shape. Some horizontal grinding marks are visible over the cutting edge.

Fig. 3



Use: The edge seems reasonably undamaged, though one corner is broken. It is very rough and chipped in appearance, though this may at least partly result from later flaking of the corrosion product.

Reduction: A depression is evident on one face, associated with cracking of the metal and also a hole in the casting. This damage seems likely to be linked with the closing stage of the object's use-cycle. It may, for example, result from hammering inflicted during the removal of the axehead from its haft.

15/07 (Acc. No. 1956: 11-2: 7)

Description: Socketed axe of 'south-eastern' type. It bears a variant on the wing-decorated pattern, with the wings merging into a horizontal rib which encircles the body.

Dimensions: Length: 102mm. Cutting edge: 46mm. Weight: 224.9g.

Patina: Thick mid-green, details obscured.

Manufacture: The mouth is uneven in appearance, implying an inadequate supply of metal during casting. Stumps of the feeders remain visible at the mouth, and the seam survives here in places, too. The top seam is sharp and prominent, showing little sign of having been flattened, though the finish is better over the final third of the piece towards the cutting edge, with the seam obliterated completely over the last c.10mm. The lower seam is similar, remaining obtrusive even over the loop, where the protruding shape of a chaplet can be seen. There are some horizontal grinding marks visible over the cutting edge on the side not illustrated, and the cutting edge has a somewhat crescentic appearance.

Use: The blade shows a high degree of uneven wear. Only one corner of the cutting edge remain intact, and this is blunt. The rest is badly broken and chipped.

Reduction: The object is complete, with no evidence relating to this process.

15/08 (Acc. No. 1931: 3-14: 2)

Description: Socketed axe, of 'south-eastern' type. It bears a variant on the wing-decorated pattern, the lower wing dividing into two parallel ribs on the underside of the piece.

Dimensions: Length: 108mm. Cutting edge: 52mm. Weight: 222.8g.

Patina: Thick dark green, with some bronze showing, and details locally reasonable.

Manufacture: The bronze is pitted in places on one face. The seams and feeders have been removed around the mouth, but on the body both upper and lower seams remain sharp and prominent. They have, however, been virtually obliterated over the lowermost third of the piece towards the cutting edge, and over the loop the seam has been well flattened and polished to the point of invisibility. There are some vertical grinding marks visible in the vicinity of the decoration, and some horizontal examples running over the cutting edge. The cutting edge has a rather crescentic appearance.

Use: The blade has been resharpened, by hammering and then grinding back to a sharp edge. A slight depression in the lower blade, associated with a faint undulation in the cutting edge might result from this. Little of the edge remains intact. Where it survives, it is blunted and chipped in appearance, with large pieces missing from its length.

Reduction: Small tool marks are visible in the vicinity of the collar, and these are probably associated with the removal of the haft.

15/09 (Acc. No. 1956: 11-2: 5)

Description: Socketed axe, of wing-decorated 'south-eastern' type. Two internal ribs are visible, but one does not start exactly at the opening of the mouth.

Dimensions: Length: 106mm. Cutting edge: 52mm. Weight: 230.0g.

Patina: Rough light green, details obscured.

Manufacture: The mouth is well-finished, with no traces of feeders or seams apparent. The uppermost seam still shows as a thin line upon the surface, and has been removed over the final third of the piece towards the cutting edge. The lower seam has been virtually obliterated over the loop and, like the upper example, is virtually invisible over the lowermost third of the piece. There are horizontal and vertical grinding marks visible over the edge, which has a faint bevel remaining in places.

Use: The axehead has been resharpened. Some of the edge remains intact, but is chipped and blunted over its length, with some large notches present.

Reduction: The axehead is complete with no evidence relating to this process.

15/10 (Acc. No. 1931: 3-14: 4)

Description: Socketed axe of 'south-eastern' type, with two collar mouldings. Wing-and-pellet decoration is clearly visible on one face, while the other is wing-decorated, with a central lump that may represent a misshapen pellet.

Dimensions: Length: 92mm. Cutting edge: 48mm. Weight: 181.2g.

Patina: Thick dark green/olive, with much bronze remaining. Details good.

Manufacture: The stumps of the feeders remain, but the intervening seam around the mouth is absent. The upper casting seam has been flattened and polished, but remains prominent to a point roughly halfway down the piece, while the lower seam is virtually invisible below the loop. There is evidence of fine hammering on the lower body, and horizontal grinding marks can be identified over the cutting edge, which is crescentic in shape.

Use: The edge appears to have been resharpened, and is now rather thin. It is broken and chipped over its length, remaining intact only at one corner.

Reduction: Hammering on the body has led to a depression in the face and the casting has cracked in one location (not illustrated). There are small tool marks evident in the vicinity of the decoration.

15/11 (Acc. No. 1931: 3-14: 14B)

Description: Socketed axe, of 'south-eastern' type. One clear central pellet is visible, with two fainter pellets flanking it. The decoration seems much clearer on one face than on the other.

Dimensions: Length: 94mm. Cutting edge: 51mm. Weight: 254.1g.

Patina: Rough light-green, with some patches of dense bronze/olive remaining. Details are locally good.

Manufacture: Vestigial traces of one feeder remain at the mouth, but the piece is otherwise well-finished here. The uppermost casting seam has been largely removed, but it remains visible over all except the lowermost third of the piece towards the cutting edge, where it has been obliterated. The lower seam is similar, but it can be identified to a point just behind the cutting edge, and it has been well-flattened over the loop. There are vertical grinding marks visible in places on the upper body, and some diagonal and vertical grinding marks apparent over the blade. The cutting edge itself bears horizontal grinding marks, and is somewhat crescentic in appearance.

Use: The cutting edge seems worn, and is now very battered and blunt in appearance. It remains intact only over the lowermost corner, and it is very blunt here.

Reduction: Chisel marks are visible inside the mouth, and these may have resulted from the removal of the haft.

15/12 (Acc. No. 1931: 3-14: 12)

Description: Socketed axe, of undecorated 'south-eastern' type.

Dimensions: Length: 101mm. Cutting edge: 50mm. Weight: 296.9g.

Manufacture: The feeders and intervening seam around the mouth have been roughly trimmed and flattened. The top seam has been roughly ground and flattened, remaining visible right down to the cutting edge, while the lower seam is prominent until about a third of the way back from the cutting edge. Traces of the seam can be identified over the loop in this example. Some horizontal grinding marks are visible above the cutting edge, which is crescentic in appearance.

Use: The edge remains even and symmetrical, but is very blunt, and seems rather battered and chipped in appearance.

Reduction: There is a chisel mark on the collar, and this could be linked with the removal of the haft.

15/13 (Acc. No. 1931: 13A)

Description: Socketed axe, of undecorated 'south-eastern' type. Two internal ribs are present.

Dimensions: Length: 99mm. Cutting edge: 53mm. Weight: 263.2g.

Patina: One face is a thick bright/dark green. The other seems much rougher, with all details now being virtually invisible.

Manufacture: The stumps of the feeders remain visible at the mouth. The top seam is quite sharp, and does not appear to have been flattened or smoothed, remaining evident almost to the blade edge. The lower seam is flatter, though again it is visible right down to the cutting edge. The cutting edge is crescentic in appearance.

Use: The edge is badly notched and broken at either corner, and is chipped along the remainder of its length.

Reduction: There are chisel marks visible on the body, and these may be related to the separation of axehead and haft, but nothing else can be seen.

15/14 (Acc. No. 1931: 3-14: 13B)

Description: Socketed axe, of undecorated 'south-eastern' type. Two interior ribs are visible.

Dimensions: Length: 104mm. Cutting edge: 52mm. Weight: 222.8g.

Patina: Thick mid-green, with some rough patches. Details locally reasonable.

Manufacture: The seam remains quite prominent around the mouth. On the body, the upper seam has been largely obliterated, though it remains visible over the collar mouldings. The lower seam has been flattened but can still be seen over much of its length, though it has been removed over the loop. The edge is crescentic in appearance.

Use: Large chunks are broken out of the edge.

Reduction: One face (illustrated) shows a depression on the upper body, possibly caused by hammering. A cluster of hammer marks can be seen below this. On the other face, there is a cluster of small circular impressions, probably made by a punch or similar tool, and there are some small notches present around the mouth which may be chisel marks.

15/15 (Acc. No. 1931; 3-14: 13C)

Description: Socketed axe, of undecorated 'south-eastern' type. Two very prominent internal ribs are present.

Dimensions: Length: 104mm. Cutting edge: 46mm. Weight: 221.9g.

Patina: Thick olive with some smooth pale-green patches in places. Details locally good.

Manufacture: The stumps of three feeders remain prominent around the mouth. These have been only roughly trimmed, though elsewhere the intervening seam has been removed. On the body, the upper seam remains sharp and prominent, though it has been obliterated over the last c.20mm back from the cutting edge. The lower seam is similar, but may be visible down to the cutting edge, appearing prominent until c.10mm back from the edge, where it is obscured by the patina. It has been flattened more extensively over the loop. There is hammering evident on the body, and this appears rather rough in places. Horizontal grinding marks are visible over the cutting edge.

Use: One corner has broken away, and the other seems blunt. In spite of its poor condition, it appears to have been resharpened, as a faint bevel and grinding marks are apparent. Much of the edge has a battered appearance, though.

Reduction: There is a slight depression evident in the upper body, associated with rough hammer indents. This may be associated with the closing stages of the object's life.

15/16 (Acc. No. 1931: 3-14: 14)

Description: Socketed axe, of undecorated 'south-eastern' type, with thick and prominent interior ribs present

Dimensions: Length: 95mm. Cutting edge: 48mm. Weight: 191.5g.

Patina: Rough grey-green. Occasional polished mid-green patches remain, and here the detail is good, but elsewhere it is poor.

Manufacture: One feeder remains in vestigial form at the mouth, but elsewhere almost all traces of feeders and seams have been removed. The upper seam remains thin and sharp right down to the cutting edge, with no indications of flattening, and the lower seam is similar, though no traces remain over the loop. There are some vertical grinding marks on the upper body. The cutting edge is crescentic in appearance.

Use: The edge is unevenly worn, and is very battered and chipped, though its poor condition has been at least partly exaggerated through recent flaking of the corrosion product.

Reduction: The axehead is complete, with no evidence relating to this process.

15/17 (Acc. No. 1931: 3-14: 13D)

Description: Socketed axe, of undecorated 'south-eastern' type, with internal ribs present.

Dimensions: Length: 100mm. Cutting edge: 50mm. Weight: 258.8g.

Patina: Rough mid-green, details largely obscured.

Manufacture: The mouth is largely well-finished, but vestigial traces of a feeder and the seam can still be seen. The upper casting seam is smooth and flattened, and has been obliterated over the lowermost third of the piece towards the blade. The situation is similar on the underside, but the seam has been flattened more thoroughly and also ground here, which means that it has now been virtually obliterated. Some traces of hammering on the lower surface, near the blade, may be linked with the removal of the seam, but this seems rather rough and carelessly executed. There are some horizontal grinding marks over the cutting edge, which is crescentic in shape.

Use: Around half of the edge remains reasonably sharp, but elsewhere large pieces have been broken from it.

Reduction: There are some rough hammer marks on the top surface which could be linked with this process, and some small chisel marks are visible on one face (not illustrated).

15/18 (Acc. No. 1931: 3-14: 14C)

Description: Socketed axe, of undecorated 'south-eastern' type, with two ribs on the interior.

Dimensions: Length: 96mm. Cutting edge: 46mm.

Patina: Bronze/olive, with some rough green patches, details poor.

Manufacture: The mouth is uneven, with a rounded hole on one side which results from a casting flaw. There is an additional flaw visible in the lower collar moulding, where a hole in the piece indicates that the molten metal failed to flow freely in the mould. Around the mouth, the seams have largely gone. Elsewhere, on the body, the upper seam is thick and prominent until halfway down the piece, though it has been obliterated below this point. The lower seam is similar, and seems to be untrimmed between the collars and the loop, with minimal flattening over the loop. There are some vertical grinding marks visible on the upper body on one side, and the edge is crescentic in appearance.

Use: The cutting edge seems blunt and chipped, but is otherwise reasonable, remaining quite sharp in some places.

Reduction: The object is complete, with no evidence relating to this process.

15/19 (Acc. No. 1931: 3-14: 14A)

Description: Socketed axe, of undecorated 'south-eastern' type, with internal ribs present.

Dimensions: Length: 98mm. Cutting edge: 46mm. Weight: 205.0g.

Patina: Thick light-green, details much obscured.

Manufacture: The feeders and the seams are absent around the mouth, where the piece has an uneven appearance, probably caused by an inadequate supply of metal in the mould. The uppermost seam is prominent but flattened, and has been obliterated over the lowermost third of the piece, while the lower seam appears sharp, remaining visible to a point some c.10mm from the cutting edge, though it is absent over the loop and the upper collar. Some grinding marks are locally visible on the collar, and these may be related to the removal of the seams. The blade is crescentic in appearance.

Use: The cutting edge is badly chipped, with none of the original edge remaining, much damage having apparently taken place in antiquity.

Reduction: There are small tool marks visible on the upper body on both faces, possibly made by a chisel. There is in addition a slight depression apparent on one face (not illustrated) running from a point parallel with the lower end of the loop to the junction

between body and blade.

15/20 (Acc. No. 1931: 3-14: 15)

Description: Socketed axe, of 'south-eastern' type, with plain blade.

Dimensions: Length: 91mm. Cutting edge: 48mm. Weight: 178.6g.

Patina: Rough grey-green, details obscured.

Manufacture: At the mouth, the stumps of the feeders and the intervening seam are still apparent. On the body, the upper seam is visible, remaining rather thick right down to the cutting edge. The lower seam is similar, though the lowermost third which lies over the cutting edge is thinner and sharper, as if trimmed prior to flattening and grinding. The blade is crescentic.

Use: There are some large notches missing from the cutting edge. Where it remains intact, it seems battered and blunt.

Reduction: There are chisel marks in evidence on the upper body, probably linked with the removal of the haft.

15/21 (Acc. No. 1931: 3-14: 17)

Description: Socketed axe, of undecorated 'south-eastern' type, with two interior ribs present.

Dimensions: Length: 84mm. Cutting edge: 44mm. Weight: 163.8g.

Patina: Rough olive/light green. details obscured.

Manufacture: The mouth has been well-finished, but elsewhere little attention seems to have been paid to removing the seams. The upper seam is very thick and prominent; though it has been obliterated over the final c. 10mm, possibly as a result of expanding the blade. The lower seam is better, remaining visible only in vestigial form over the lowermost third of the piece, though it is still prominent over the collar. There are horizontal grinding marks evident over the cutting edge, which is crescentic in appearance.

Use: The blade is battered and broken, with none of its original edge remaining, though some of this damage may have been exaggerated by flaking corrosion product.

Reduction: The object is complete, with no evidence relating to this process.

15/22 (Acc. No. 1931: 3-14: 18)

Description: Socketed axe, of undecorated 'south-eastern' type.

Dimensions: Length: 86mm. Cutting edge: 34mm. Weight: 149.5g.

Patina: Rough mid-green, details obscured.

Manufacture: The mouth appears rough, with the stump of one feeder surviving. The upper seam remains quite prominent over the body, though it has been flattened along its length. The lower seam remains visible over the loop, but appears to have been obliterated over the lower half of the piece, though the corrosion product obscures much detail here. The blade is blunt, and appears unexpanded.

Use: Though the seams have been trimmed to some extent, the narrow blade suggests that the object was never used.

Reduction: The object is complete, with no evidence relating to this process.

15/23 (Acc. No. 1931: 3-14: 19)

Description: Socketed axe, of undecorated 'south-eastern' type. It is small in size, with internal ribs present.

Dimensions: Length: 72mm. Cutting edge: 42mm. Weight: 137.5g.

Patina: Rough grey-green, details obscured.

Manufacture: The mouth is slightly misshapen. A dip in the casting here suggests that an inadequate supply of metal was used. The mouth is otherwise well-finished. The upper seam has been trimmed and flattened, though it still remains visible. The lower is similar, but has been flattened over the loop. The cutting edge is crescentic in appearance.

Use: The edge is battered, and there are large chunks missing from its length.

Reduction: The object is complete, with no evidence relating to this process.

15/24 (Acc. No. 1931: 3-14: 20)

Description: Socketed axe, of undecorated 'south-eastern' type, and small in size. The faint trace of an interior rib is visible on one side of the mouth, though the metal appears

rough here, and this detail cannot be securely ascertained. This example is unusual in that the upper and lower collar mouldings merge halfway across the face (illustrated).

Dimensions: Length: 67mm. Cutting edge: 38mm. Weight: 99.0g.

Patina: Rough mid-green, details obscured.

Manufacture: The mouth is well-finished, with seam and feeders removed. The upper seam is thin, and is evident only to a point just past the collar mouldings. The lower seam is present only on the upper body, remaining thin and prominent over the upper collar and between the loop and the lower body, but obliterated over the loop and the underside of the blade. The cutting edge has a crescentic appearance.

Use: The edge seems blunt and battered along its length.

Reduction: The object is complete and there is no evidence relating to this process.

15/25 (Acc. No. 1931: 3-14: 23)

Description: Socketed axe, of 'south-eastern' type, probably undecorated.

Dimensions: Length: 78mm. Cutting edge: 35mm. Weight: 89.4g.

Patina: Rough grey-green, details obscured.

Manufacture: The wall seems thin at the break, indicating core misalignment. In addition, the loop seems rather misshapen, suggesting that the molten metal failed to flow properly in the mould. The mouth has been well-finished. On the body, the upper seam is prominent, though flattened, to c.10mm back from the cutting edge, the lower appearing better finished, having been almost obliterated over the loop. The blade seems to have been expanded, but remains narrow in shape.

Use: Though it is possible that this piece was finished but never subject to actual use, some doubt is cast on this suggestion by the slightly uneven appearance of the cutting edge. Such damage may have resulted from wear, though the cutting edge remains complete despite its unusually blunt appearance.

Reduction: Both faces have been hammered inwards in the vicinity of the mouth, and extensive cracking and breakage has occurred as a result.

15/26 (Acc. No. 1956: 11-2: 1)

Description: Socketed axe, of undecorated 'south-eastern' type, with two internal ribs present.

Dimensions: Length: 100mm. Cutting edge: 56mm. Weight: 264.4g.

Patina: Rough grey-green, details obscured.

Manufacture: Stumps of the feeders remain visible at the mouth, and much of the intervening seam survives here, too. The upper seam has been largely removed over the body, remaining visible as a flattened but prominent trace to a point roughly a half or two-thirds of the way down the piece. The lower seam is less well-finished, though it has been flattened over much of its length, and has been smoothed down well over the loop. Some chisel marks, visible just above the cutting edge, may be linked with the trimming of the lower seam. There are indications of fine hammering over the cutting edge, associated perhaps with the initial working of the blade, or resharpening. The blade is crescentic in appearance.

Use: The blade is unevenly worn. It is blunt over its whole length, but one corner shows significantly more damage, with some sizable chunks missing.

Reduction: The axehead is complete, with no evidence relating to this process.

15/27 (Acc. No. 1956: 11-2: 2)

Description: Socketed axe, of undecorated 'south-eastern' type, with two internal ribs present.

Dimensions: Length: 94mm. Cutting edge: 56mm. Weight: 265.6g.

Patina: Rough grey-green.

Manufacture: There are three dips evident in the collar, one rather extreme, and these indicate minor casting flaws. In addition, the surface seems rougher on the side illustrated. This might indicate a poor quality casting, a lack of fine working over the body, or both. The mouth seems smooth and rounded over its extent, as if the metal did not fill the mould, but a length of seam in one location argues against this possibility. The upper seam appears to have been trimmed, but remains sharp to c.10mm back from the cutting edge.

The lower seam has also been trimmed, but vestigial traces remain along its length, except over the loop. There are some indications of grinding marks over the edge, which is somewhat crescentic in shape.

Use: The cutting edge remains largely intact, though it is battered towards the corners and is blunt along the remainder of its length.

Reduction: The axehead is complete, with no evidence relating to this process.

15/28 (Acc. No. 1956: 11-2: 3)

Description: Socketed axe of undecorated 'south-eastern' type, with faint traces of internal ribs present.

Dimensions: Length: 98mm. Cutting edge: 54mm. Weight: 244.2g.

Patina: Some bronze shows, but patina is mainly rough grey-green. Details obscured.

Manufacture: The stumps of the feeders and some lengths of the intervening seam survive around the mouth. The upper seam is prominent, and seems to have been only roughly flattened down to c.10mm back from the cutting edge. The situation is similar on the underside, though the seam has been well flattened over the loop. The cutting edge is crescentic in appearance.

Use: The edge is largely gone. Only one short length remains intact, and this is blunt. The rest is badly chipped and broken.

Reduction: The axehead is complete, with no evidence relating to this process.

15/29 (Acc. No. 1956: 11-2: 4)

Description: Socketed axe, of undecorated 'south-eastern' type.

Dimensions: Length: 91mm. Cutting edge: 52mm. Weight: 202.2g.

Patina: Rough mid-green.

Manufacture: Some traces of the seam remain visible in vestigial form around the mouth, though they appear to have been flattened down well. The upper seam is well-finished over most of the body, though some traces remain over the upper collar moulding. The lower seam has also been largely removed, with only a slight ridge in the section marking its route. The cutting edge is crescentic in appearance.

Use: The edge of the blade is chipped, and seems slightly distorted in places over its length.

Reduction: The axehead is complete, with no evidence relating to this process.

15/30 (Acc. No. 1931: 3-14: 21)

Description: Incomplete socketed axe, probably of undecorated 'south-eastern type', now missing its mouth.

Dimensions: Length (maximum): 81mm. Cutting edge: 54mm. Weight: 264.4g.

Patina: Rough green with some bronze showing, details poor.

Manufacture: The seam has been removed over the loop, but can be seen elsewhere, on both sides, to a point c.10mm back from the cutting edge. The cutting edge is crescentic in appearance.

Use: Large pieces have been broken from the cutting edge, and some of this damage may be use-related.

Reduction: The blade looks as if it has been deliberately broken in places, some of the notches being associated with thinned metal which may have been distorted as a result of hammering. The whole piece has now been completely crushed along its surviving length following hammering. Some additional fragments are visible inside the socket. One appears to be a small mouth fragment from a socketed axe, while the other cannot be identified.

15/31 (Acc. No. 1931: 3-14: 22)

Description: Mouth and upper body of socketed axe, with one rather squared-off collar moulding. The piece is decorated with four ribs on either face, with two placed centrally on the face itself, and a further two defining the interfaces between faces and upper/lower surfaces.

Dimensions: Length (maximum): 52mm. Weight: 132.4g.

Patina: Rough grey-green, with some detail visible.

Manufacture: The mouth is well-finished, but a slight dip in the collar is evidence of a minor casting flaw. In addition, one wall is markedly thinner, suggesting core misalignment. The top seam remains prominent and rather sharp, though it seems to have been roughly flattened. The lower seam is similar, but is much flattened over the loop. Vertical grinding marks can be seen running down the piece, over the collar and in the vicinity of the decoration.

Use: The wall where the metal seems thinner is cracked, damage which may be use-related.

Reduction: There are no indications of any hammering in the vicinity of the break.

15/32 (Acc. No. 1931: 3-14: 25)

Description: Long mouth fragment of wing-decorated 'south-eastern' type socketed axe, with a possible triple collar moulding.

Dimensions: Length (maximum): 63mm. Weight: 56.6g.

Patina: Rough mid-green, some bronze showing. Details poor.

Manufacture: One wall seems rather thin, indicating core misalignment. The seam is still apparent in places around the mouth, but has been removed almost entirely from the top surface, with only faint traces remaining.

Use: Cannot be determined, though the object appears to have been prepared for use.

Reduction: The piece has been crushed inwards. One face has been folded down over the upper surface, while the other is virtually absent over its extent.

15/33 (Acc. No. 1931: 3-14: 24)

Description: Lower body and blade of socketed axe, with ribbed decoration apparent.

Dimensions: Length: 68mm (maximum). Cutting edge: 53mm. Weight: 194.7g.

Patina: Rough mid-green, details obscured.

Manufacture: One wall is slightly thinner, indicating core misalignment. The seam is very thick, having been hammered flat without prior trimming. The cutting edge is crescentic.

Use: Large notches are missing from the cutting edge in places, which elsewhere is blunt in appearance.

Reduction: The object has been hammered inwards on both faces in the vicinity of the break. This distortion is more marked on the side where the wall is thinner. Individual hammer marks are visible in places here, and the ribbed decoration has been virtually obliterated.

15/34 (Acc. No. 1931: 3-14: 24)

Description: Blade fragment of socketed axe.

Dimensions: Length (maximum): 56mm. Cutting edge: 40mm. Weight: 140.1g.

Patina: Rough grey-green.

Manufacture: The seam is faintly apparent on one side, and has been obliterated on the other. There are still indications of the seam running along the blade edge. This was possibly a failed casting: the core was misaligned, and while this problem does not appear too serious here, it could have been sufficient to prevent use of the axehead.

Use: It seems likely that the piece has never been used, though the imperfect corner of the blade seems rough and sharp, which might suggest use-related damage which took place in antiquity rather than a casting defect.

Reduction: A faint depression in one face is likely to have resulted from hammering.

15/35 (Acc. No. 1931: 3-14: 24)

Description: Blade fragment of socketed axe.

Dimensions: Length (maximum): 56mm. Cutting edge: 49mm. Weight: 136.8g.

Patina: Rough grey-green, with some bronze-coloured patches.

Manufacture: One wall is considerably thinner, indicating core misalignment. On both sides the seams have been obliterated c. 20mm back from the cutting edge, though elsewhere they remain quite sharp, while having been trimmed and flattened somewhat. There are diagonal grinding marks apparent near the cutting edge, and vertical grinding marks run down the body. The edge is somewhat crescentic in appearance.

Use: Large chunks are missing from the cutting edge.

Reduction: A depression in the thinner wall is associated with a large number of superimposed hammer-marks. The section has been crushed and distorted.

15/36 (Acc. No. 1931: 3-14: 24)

Description: Blade fragment of socketed axe.

Dimensions: Length (maximum): 40mm. Cutting edge: 50mm. Weight: 81.7g.

Patina: Some bronze still shows, and the details are locally excellent.

Manufacture: One wall is rather thin, indicating core misalignment. Only a faint trace of the seam remains near the break at one side: elsewhere, it has been obliterated. The blade is crescentic in appearance, with a faint bevel apparent along the cutting edge.

Use: The blade seems good, but is blunt in a few places. This may, however, be associated with modern damage, as the metal here is bright and polished.

Reduction: Cracking is apparent in the interior of the piece on the thicker wall. This may be use-related, or may be related to the stress caused by hammering as the piece was broken up.

15/37 (Acc. No. 1931: 3-14: 24)

Description: Blade fragment of socketed axe.

Dimensions: Length (maximum): 35mm. Cutting edge: 47mm. Weight: 66.8g.

Patina: Rough mid-green, with occasional bronze showing. Details poor.

Manufacture: The seams have been obliterated along both sides. The edge seems well expanded, and there are no indications of any casting defects.

Use: There is one notch in the edge, which seems otherwise reasonable. One corner is blunted and seems a little misshapen at the very edge, and this may be due to a minor casting flaw as opposed to use-related damage.

Reduction: There is a possible hammer facet on one face, and a piece of rough metal has been wedged inside the base of the socket.

15/38 (Acc. No. 1931: 3-14: 24)

Description: Blade fragment of socketed axe.

Dimensions: Length (maximum): 38mm. Cutting edge: 52mm. Weight: 61.6g.

Patina: Rough mid-green.

Manufacture: One wall seems thin, indicating core misalignment. No casting seams remain visible. The blade is crescentic in appearance.

Use: While some of the cutting edge remains in good condition, roughly half of its extent is now rather battered in appearance.

Reduction: Some slight hammer impressions are visible near the break, but there are no other indications.

15/39 (Acc. No. 1931: 3-14: 24)

Description: Blade fragment of socketed axe.

Dimensions: Length (maximum): 62mm. Cutting edge: 44mm. Weight: 130.0g.

Patina: Rough grey-green, details obscured.

Manufacture: The seams are thick and, though they have been flattened, remain visible right down to the cutting edge, which seems reasonably well-expanded.

Use: A large notch is missing from the cutting edge. Otherwise, the edge is reasonable, although a little blunt.

Reduction: The faces have been hammered inwards in the vicinity of the break. There is a possible chisel mark occurring in association with this damage, as well a possible punch mark.

15/40 (Acc. No. 1931: 3-14: 24)

Description: Blade fragment of socketed axe.

Dimensions: Length (maximum): 58mm. Cutting edge: 42mm. Weight: 118.0g.

Patina: Rough grey-green, details poor.

Manufacture: One side shows no trace of the casting seam, but the piece seems rough in this area, with some fresh bronze showing, so the original nature of the surface here cannot be properly evaluated. The other seam has been largely removed, though it remains as a faint trace in places. The edge has been widely expanded.

Use: The edge appears blunt and may be unused, with no indications of chipping or notching.

Reduction: Both faces have been crushed at the break following intensive hammering. Some individual hammer-marks are present.

15/41 (Acc. No. 1931: 3-14: 24)

Description: Blade fragment of socketed axe.

Dimensions: Length: 46mm. Cutting edge: 42mm. Weight: 89.7g.

Patina: Rough grey-green, details obscured.

Manufacture: One wall is markedly thinner, indicating a misaligned core. The seams are almost completely gone - obliterated on one side, and with only faint traces apparent at the cutting edge and the break on the other. The edge appears to have been expanded.

Use: The edge seems blunt but largely undamaged, and may never have received final working prior to use. The object may therefore be unused.

Reduction: Both faces have been hammered inwards at the break, and as a result the section appears much distorted. There are no indications of individual hammer marks.

15/42 (Acc. No. 1931: 3-14: 24)

Description: Blade fragment of socketed axe.

Dimensions: Length (maximum): 41mm. Cutting edge: 39mm. Weight: 93.5g.

Patina: Rough mid-green, details obscured.

Manufacture: One wall is slightly thinner, indicating core misalignment. On one side, an extensive length of the casting seam remains thick and prominent. Here, the seam appears to have been flattened, though it may not have been trimmed. The other seam has been largely removed, but it remains visible. The blade has been expanded.

Use: Only a tiny portion of one corner of the cutting edge remains intact.

Reduction: Depressions are present on either face at the break, and the hammering which created these has caused distortion of the section.

15/43 (Acc. No. 1931: 3-14: 24)

Description: Blade fragment of socketed axe.

Dimensions: Length (maximum): 60mm. Cutting edge: 36mm. Weight: 74.4g.

Patina: Rough grey-green, details obscured.

Manufacture: There are no indications of core misalignment. The seam has been virtually obliterated along one side, but on the other traces remain near the break. The blade does not appear to have been expanded.

Use: There are slight dips apparent in the cutting edge in two places. The metal appears rounded here, and so it can be suggested that these anomalies represent casting defects. Because of these, the piece may never have been used.

Reduction: There are indentations on either face in the area of the break, and the section shows slight distortion here, though no individual hammer-marks can be seen, probably on account of the patina.

15/44 (Acc. No. 1956: 11-2: 8)

Description: Blade fragment of socketed axe.

Dimensions: Length (maximum): 56mm. Cutting edge: 54mm. Weight: 122.8g.

Patina: Some bronze/olive remaining, with mid-green patches obscuring the surface detail in places.

Manufacture: One wall seems particularly thin, indicating core misalignment. The seams are visible on both sides, but have been largely removed, with only faint traces remaining. Some horizontal grinding marks are visible near the cutting edge in places, and the blade is crescentic in shape.

Use: The edge is largely intact, and though it shows signs of chipping in places, it remains quite sharp over its length.

Reduction: There are depressions apparent on both faces at the break, and the section is distorted here. Some hammer-marks can be seen in association with this damage, and these seem particularly long and slim. They cannot have been inflicted by either a trunnion chisel or a socketed hammer, and the nature of the object that created them cannot be ascertained.

15/45 (Acc. No. 1931: 3-14: 24)

Description: Blade fragment of socketed axe.

Dimensions: Length (maximum): 50mm. Cutting edge: 40mm. Weight: 69.6g.

Patina: Rough grey-green. Details obscured.

Manufacture: One wall is very thin. This indicates core misalignment, the severe nature of which can be attested by the rounded edge of the hole apparent in one face (not illustrated). It is probable that this hole represents the surviving evidence of a serious casting defect. The casting seams have been largely obliterated on one side, while on the other no traces are visible. This implies that the object was prepared for use, but the blade does not appear to have been expanded, and there appear to be faint traces of a casting seam evident along the cutting edge.

Use: It is likely that the object was never used.

Reduction: No evidence can be found which relates to this process.

15/46 (Acc. No. 1931: 3-14: 10)

Description: Socketed chisel, with a faintly ribbed appearance to the exterior.

Dimensions: Length: 59mm. Cutting edge: 34mm. Weight: 27g.

Patina: Rough mid-green, details obscured.

Manufacture: The seams are still prominent, but they have been flattened and they are now smooth in appearance. The mouth has been very well finished. A faint bevel is apparent, running along the blade edge.

Use: A small hole is visible in one side of the object, and there are cracks associated with this, but its appearance is rough, which might suggest use-related damage as opposed to a casting defect. The cutting edge seems fine and sharp.

Reduction: The object is complete and there is no evidence relating to this process.

15/47 (Acc. No. 1931: 3-14: 11)

Description: Socketed gouge, with two collar mouldings. The upper moulding is well-defined and prominent, the lower one rather vague.

Dimensions: Length: 66mm. Weight: 42.9g.

Patina: Rough mid-green, with occasional bronze patches.

Manufacture: The mouth appears well-finished, but on the body the seams remain prominent and quite sharp on either side. Vertical grinding marks run down the interior of the blade.

Use: The cutting edge seems rather chipped and battered.

Reduction: Some notches on the collar may be related to the removal of the handle or haft.

15/48 (Acc. No. 1931: 3-14: 9)

Description: Two adjoining fragments of Ewart Park type sword. They comprise the hilt/shoulders, and an adjoining blade fragment. Four rivet holes have been punched through the piece - one on either shoulder and another two in the tang - and there is a 'blank' for a third rivet hole lying between the others in the tang.

Dimensions: Combined length (maximum): 240mm. Weight: 268.7g.

Patina: Rough grey-green, details obscured.

Manufacture: There is evidence of fine hammering to be seen along the length of the tang. The casting seams have been removed from the sides of the tang and the blade, but the butt of the tang still appears rather rough. Fine bevels are evident, running along either cutting edge.

Use: One edge remains fine and sharp, though three minor notches are present along its length. The other seems more battered, with none of the original edge remaining from the ricasso to the break, though below this point the blade does not appear too badly damaged.

Reduction: A hammer indent is visible on the upper break on one side (not illustrated). The lower break shows another tiny hammer mark, but this must remain tenuous. There is no bend or distortion visible in the profile of the piece.

15/49 (Acc. No. 1931: 3-14: 8)

Description: Blade tip from undecorated hollow-sectioned socketed spearhead.

Dimensions: Length (maximum): 88mm. Weight: 46.2g.

Patina: Rough mid-green. Details reasonable.

Manufacture: One wall appears thin at the break, indicating core misalignment. No traces of any seams can be seen, and a faint bevel runs down either blade edge. Vertical striations are visible on the blade.

Use: The blade edges are chipped and battered.

Reduction: There is an indentation visible at the lower break, and further depressions can be seen halfway up the piece. The indentation at the base appears to have occurred where the metal is thinner, suggesting a concentration of blows at the weakest point in the casting.

15/50 (Acc. No. 1931: 3-14: 7)

Description: Socket and lower blade of socketed spearhead, with a fillet-defined midrib apparent. These fillets continue beyond the blade on either side, becoming broad flat bands which encompass either rivet hole. Concentric incised lines run around the socket.

Dimensions: Length (maximum): 87mm. Weight: 79.3g.

Patina: Rough light green, with olive patches. Details obscured.

Manufacture: One wall seems thinner, suggesting core misalignment. The seams have been removed, and there is a faint bevel apparent running along either edge.

Use: The decoration seems rather worn.

Reduction: The midrib has been hammered in two locations near the break, causing crushing. A slight notch on one side (not illustrated) may be a punch mark.

15/51 (Acc. No. 1931: 3-14: 6)

Description: Hog-backed knife.

Dimensions: Length: 83mm. Width: 49mm. Weight: 98.6g.

Patina: Thick light grey-green, some bronze patches showing.

Manufacture: No seams are apparent along the edges, but the hole by which the piece was once attached to its ?handle has been punched through an area of thinned metal. Much of this still survives. No grinding marks are visible, though there is a bevel visible running along the blade.

Use: No use-related damage can be identified.

Reduction: The object is complete and there is no evidence relating to this process.

15/52 (Acc. No. 1931: 3-14: 26)

Description: Complete copper ingot.

Dimensions: Diameter: 130mm. Thickness: 33mm. Weight: 1589.6g.

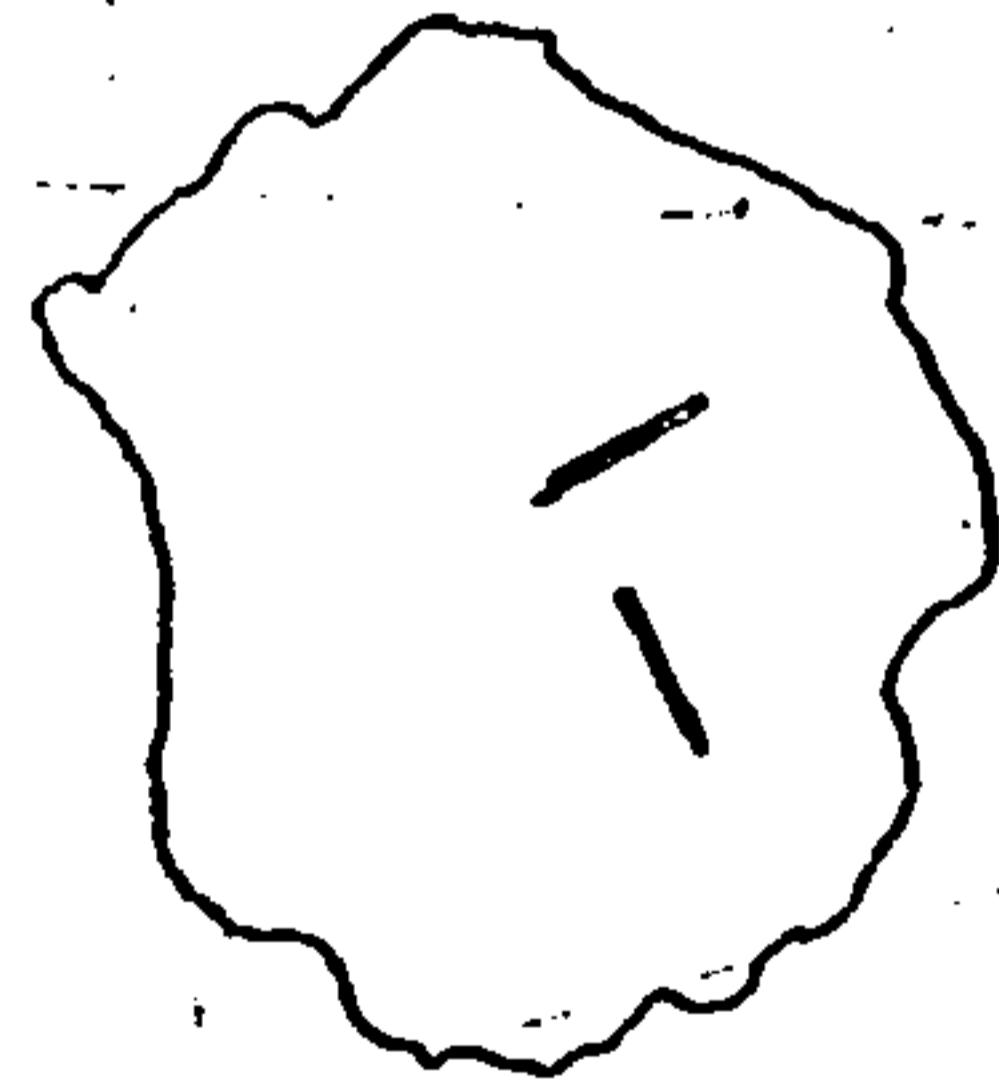
15/53 (No Accession Number)

Description: Small piece of copper cake.

Dimensions: Length: 48mm. Width: 57mm. Thickness: 23mm. Weight: 209.7g.

Observations: There are two possible chisel marks on the underside (fig.4), though these are very deep and may in fact have come from a blow from a more substantial object, such as an axe.

Fig. 4



15/54 (No Accession Number)

Description: Small piece of copper cake.

Dimensions: Length: 55mm. Width: 41mm. Thickness: 25mm. Weight: 278.1g.

Observations: None.

15/55 (Acc. No. 1931: 3-14: 29)

Description: Complete copper cake, small in size.

Dimensions: Diameter: 91mm. Thickness: 28mm. Weight: 624.2g.

15/56 (No Accession Number)

Description: Small piece from edge of copper ingot, with a pitted appearance to either surface.

- Dimensions:** Length: 50mm. Width: 36mm. Thickness: 24mm. Weight: 150.8g.
15/57 (No Accession Number)
Description: Large piece of copper cake, comprising roughly half of its original extent. One surface is still covered by soil which adheres to it, while the underside shows indication of modern damage.
Dimensions: Length: 122mm. Width: 81mm. Thickness: 38mm. Weight: 935.3g.
15/58 (No Accession Number)
Description: Large piece of copper cake, with substantial voids present in the interior of the piece.
Dimensions: Length: 98mm. Width: 62mm. Thickness: 26mm. Weight: 452.3g.
15/59 (No Accession Number)
Description: Large piece of copper cake.
Dimensions: Length: 86mm. Width: 66mm. Thickness: 34mm. Weight: 560.0g.
Observations: Some small chisel marks are visible near the break on the flatter surface.
15/60 (Acc. No. 1931: 3-14: 27)
Description: Piece of copper cake, with some large voids present in the interior.
Dimensions: Length: 81mm. Width: 61mm. Thickness: 26mm. Weight: 489.0g.
15/61 (No Accession Number)
Description: Edge piece from copper cake.
Dimensions: Length: 78mm. Width: 63mm. Thickness: 31mm. Weight: 544.4g.
Observations: A flattened, smooth and burred appearance to one edge suggests possible re-use as a hammer.
15/62 (Acc. No. 1956: 11-9: 9)
Description: Piece of copper cake.
Dimensions: Length: 95mm. Width: 52mm. Thickness: 36mm. Weight: 761.4g.
15/63 (No Accession Number)
Description: Large piece of copper cake, with voided appearance to the interior.
Dimensions: Length: 94mm. Width: 74mm. Thickness: 38mm. Weight: 749.4g.
15/64 (No Accession Number)
Description: Edge fragment of copper cake, with many voids evident in the bronze, including one which runs along the length of the edge.
Dimensions: Length: 47mm. Width: 46mm. Thickness: 15mm. Weight: 160.1g.
15/65 (No Accession Number)
Description: Piece from edge of copper cake, with voided appearance.
Dimensions: Length: 55mm. Width: 36mm. Thickness: 20mm. Weight: 171.5g.
Observations: The surface of the metal seems very smooth, but since fresh metal is visible here, this might indicate damage which took place more recently, e.g. extensive stripping of corrosion products.
15/66 (No Accession Number)
Description: Piece from interior of copper cake.
Dimensions: Length: 76mm. Width: 56mm. Thickness: 26mm. Weight: 481.3g.
15/67 (No Accession Number)
Description: Piece from edge of copper cake.
Dimensions: Length: 62mm. Width: 52mm. Thickness: 38mm. Weight: 469.1g.
15/68 (No Accession Number)
Description: Piece from edge of copper cake, very thick in section.
Dimensions: Length: 57mm. Width: 72mm. Thickness: 45mm. Weight: 652.8g.
Observations: Modern damage is apparent, with fresh copper showing in places.
15/69 (No Accession Number)
Description: Piece from edge of copper cake.
Dimensions: Length: 72mm. Width: 56mm. Thickness: 38mm. Weight: 630.6g.

15/70 (No Accession Number)

Description: Piece from edge of copper cake, with a voided appearance to the metal.

Dimensions: Length: 64mm. Width: 50mm. Thickness: 27mm. Weight: 249.1g.

15/71 (No Accession Number)

Description: Edge from copper cake.

Dimensions: Length: 75mm. Width: 50mm. Thickness: 33mm. Weight: 526.0g.

15/72 (No Accession Number- probably from Bexley Heath hoard)

Description: Piece of copper cake, with very rough, irregular appearance.

Dimensions: Length: 60mm. Width: 62mm. Thickness: 23mm. Weight: 216.8g.

15/73 (No Accession Number)

Description: Piece from edge of copper cake, with a voided appearance to the interior.

Dimensions: Length: 42mm. Width: 40mm. Thickness: 19mm. Weight: 99.1g.

15/74 (No Accession Number)

Description: Edge fragment of copper cake, with large voids present in the metal.

Dimensions: Length: 63mm. Width: 52mm. Thickness: 29mm. Weight: 363.7g.

15/75 (No Accession Number)

Description: Interior fragment of copper cake.

Dimensions: Length: 50mm. Width: 46mm. Thickness: 24mm. Weight: 270.2g.

15/76 (No Accession Number)

Description: Piece from edge of copper cake.

Dimensions: Length: 50mm. Width: 46mm. Thickness: 30mm. Weight: 167.7g.

Observations: There are possible hammer-marks on one surface, associated with a rather smooth appearance to the metal.

15/77 (No Accession Number)

Description: Small piece of copper cake, with numerous voids apparent in the interior.

Dimensions: Length: 46mm. Width: 57mm. Thickness: 23mm. Weight: 209.7g.

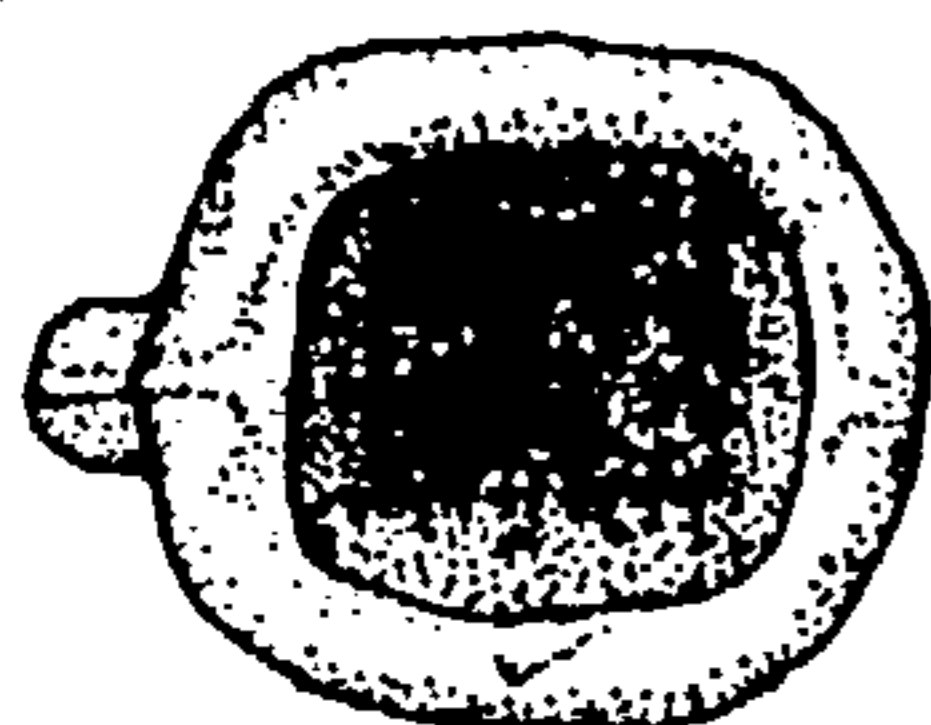
Observations: There are two deep striations apparent on one flat surface, and these appear to date to antiquity. These may be chisel marks, though they may even have resulted from striking by an axe, as substantial damage to the surface is evident, damage which a lighter object such as a chisel might not have been capable of inflicting. On the other surface there is a marked depression which may be the result of hammering.

15/78 (No Accession Number)

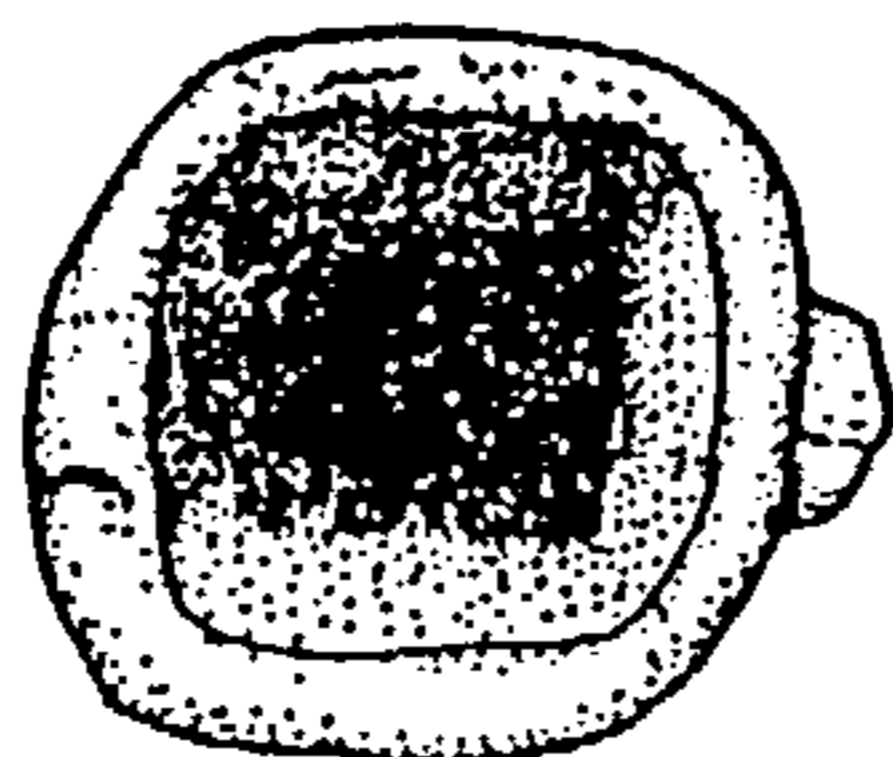
Description: Piece from edge of copper cake.

Dimensions: Length: 66mm. Width: 58mm. Thickness: 34mm. Weight: 281.3g.

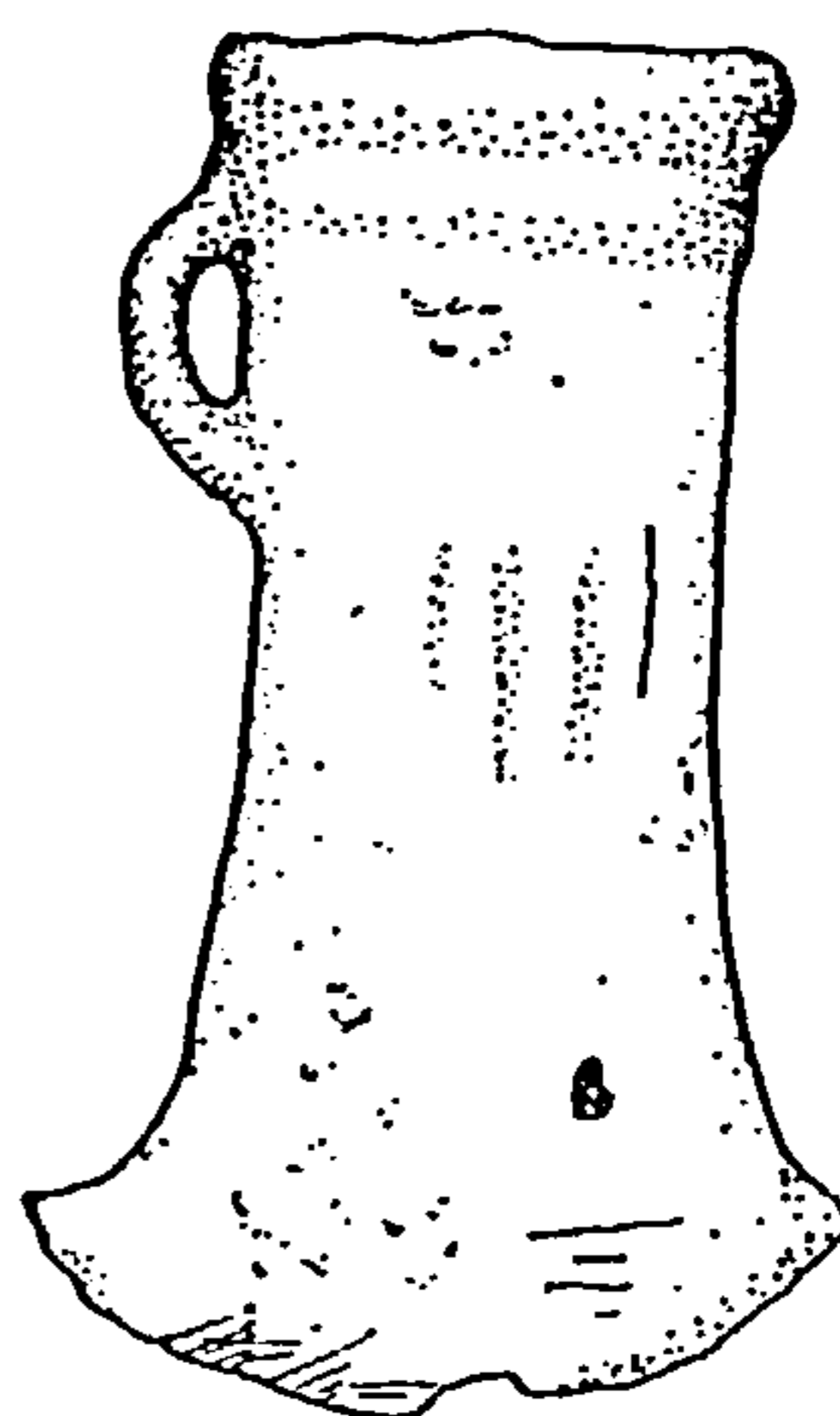
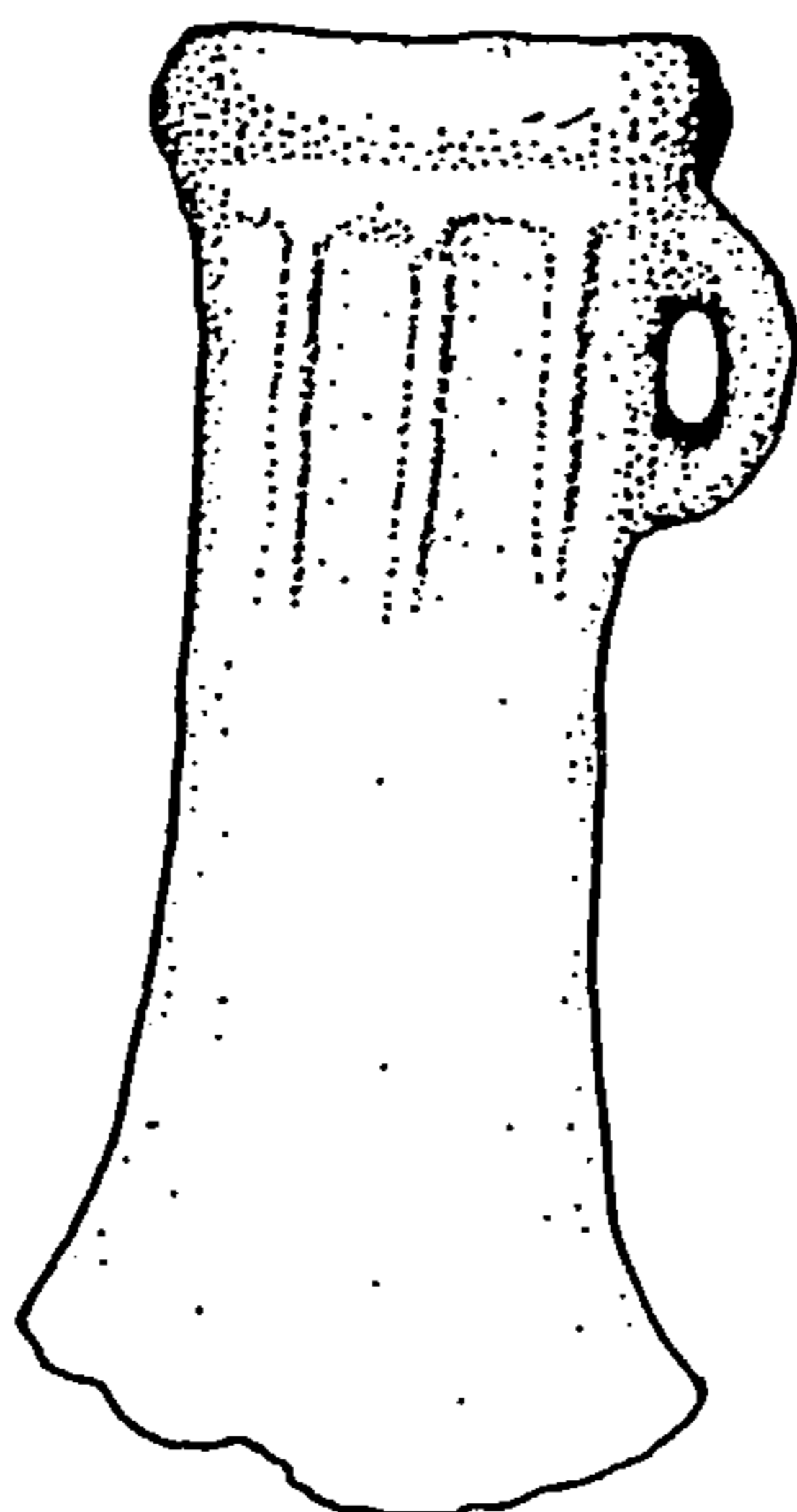
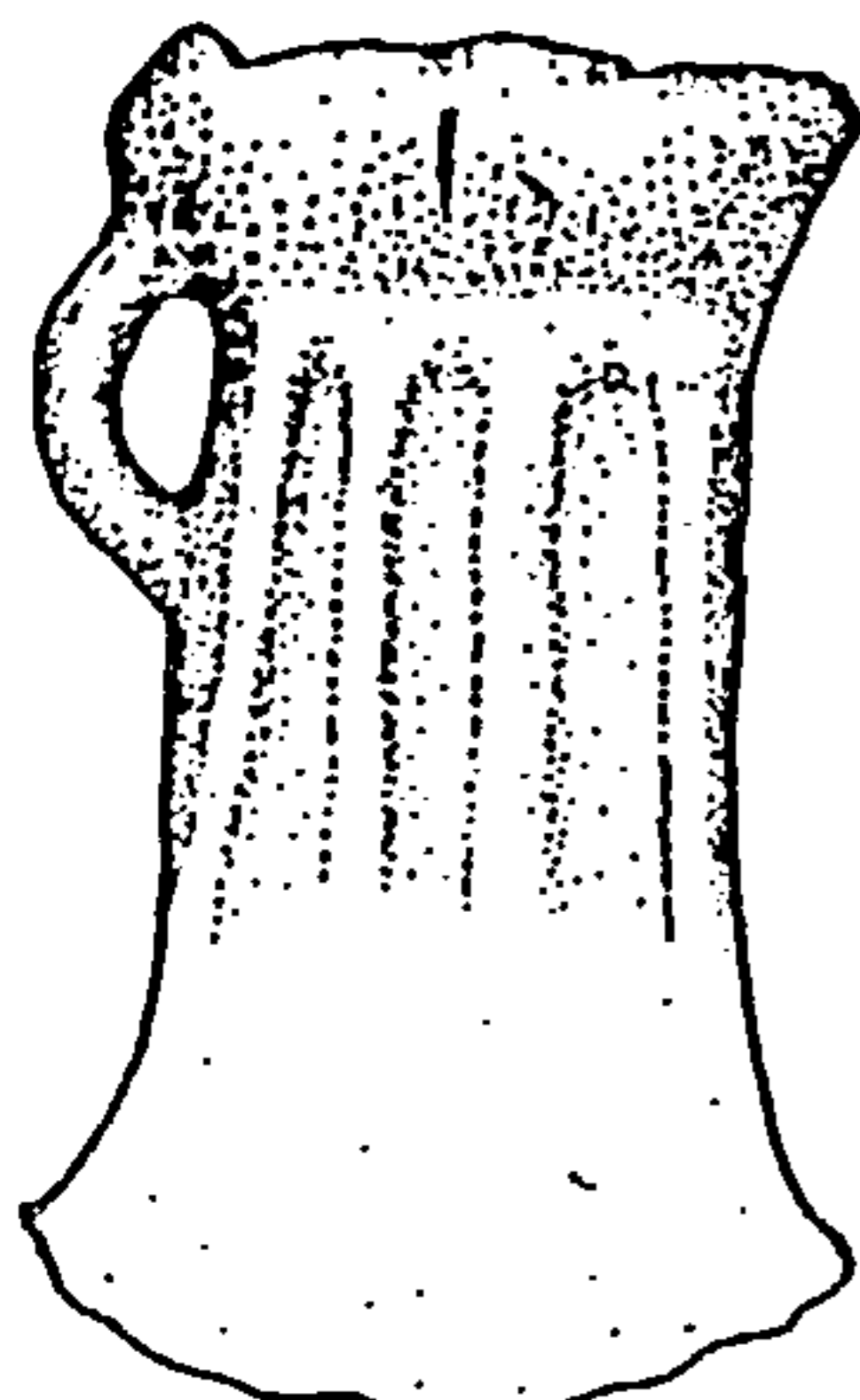
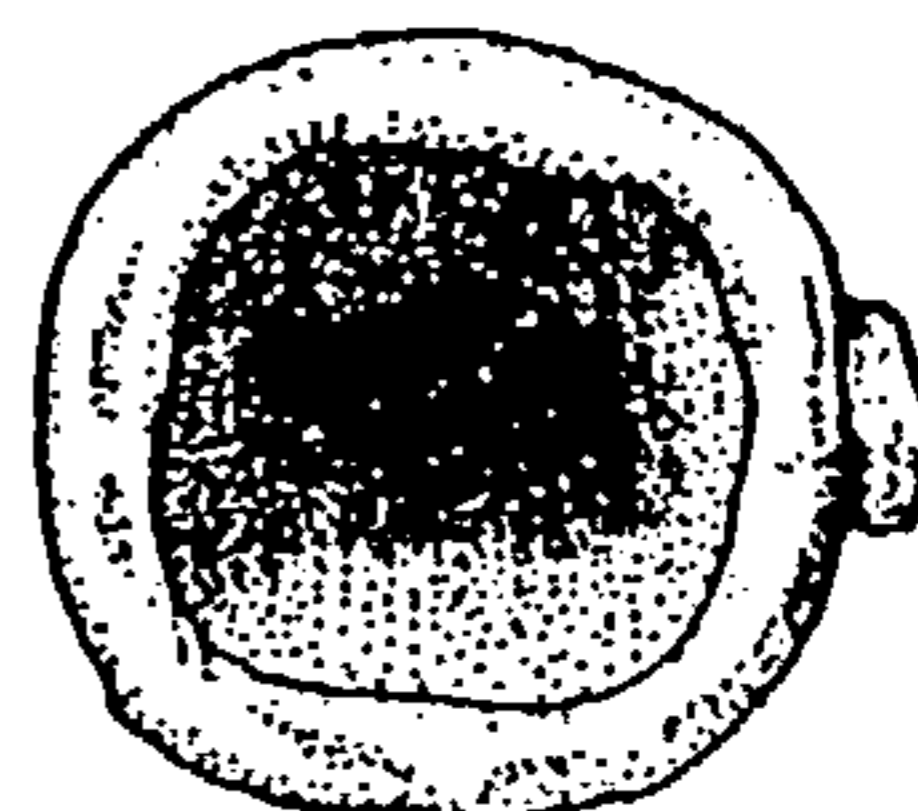
15/01



15/02

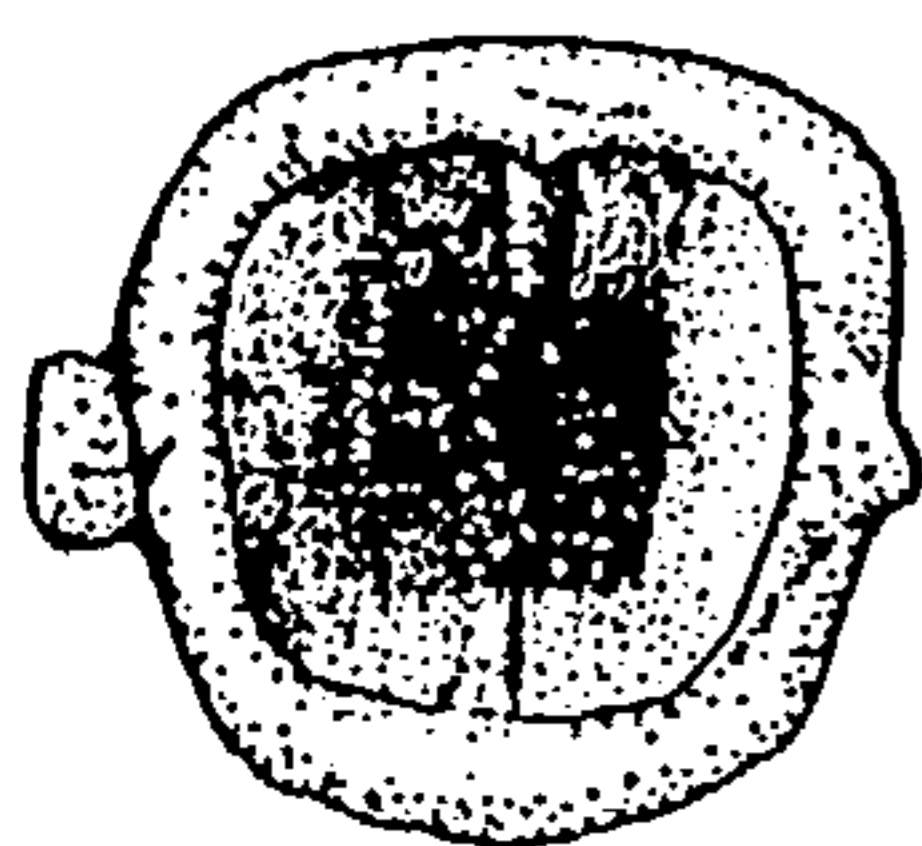


15/03



0 2cm

15/05



15/06

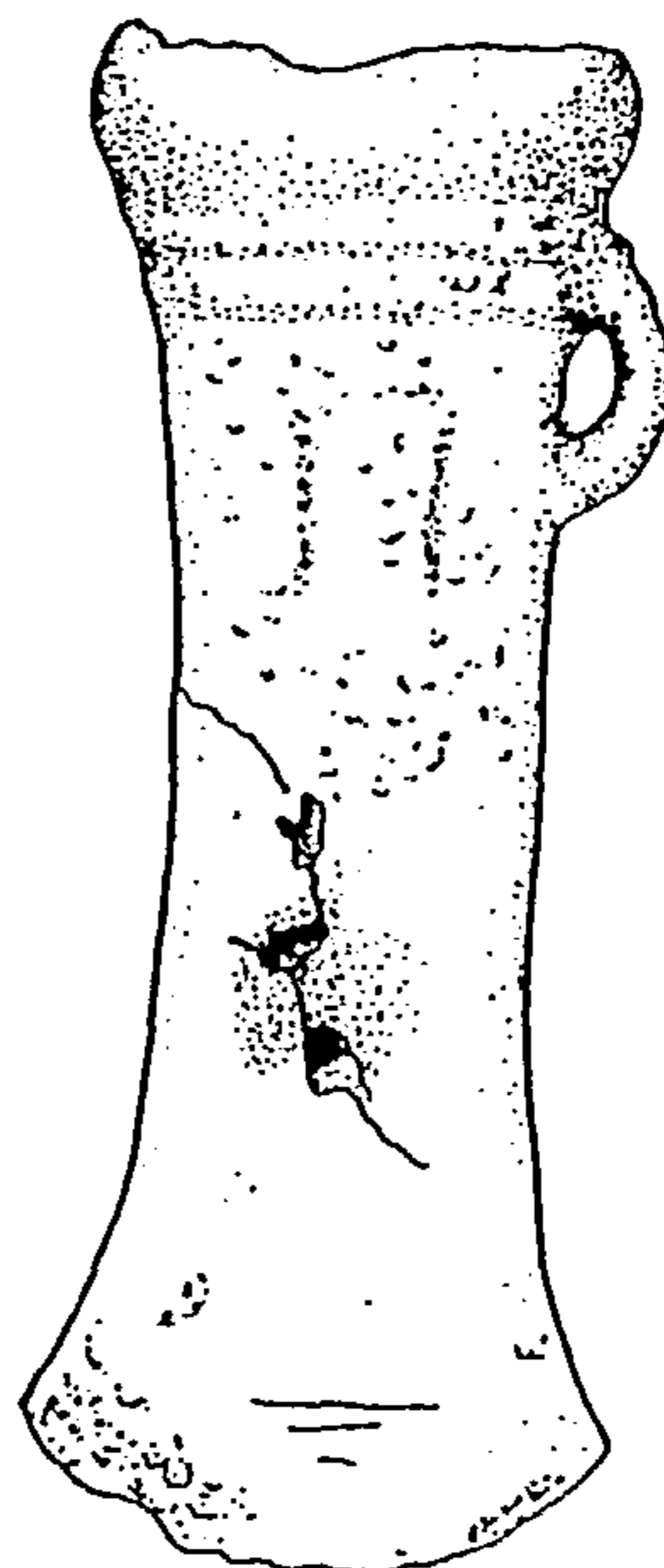
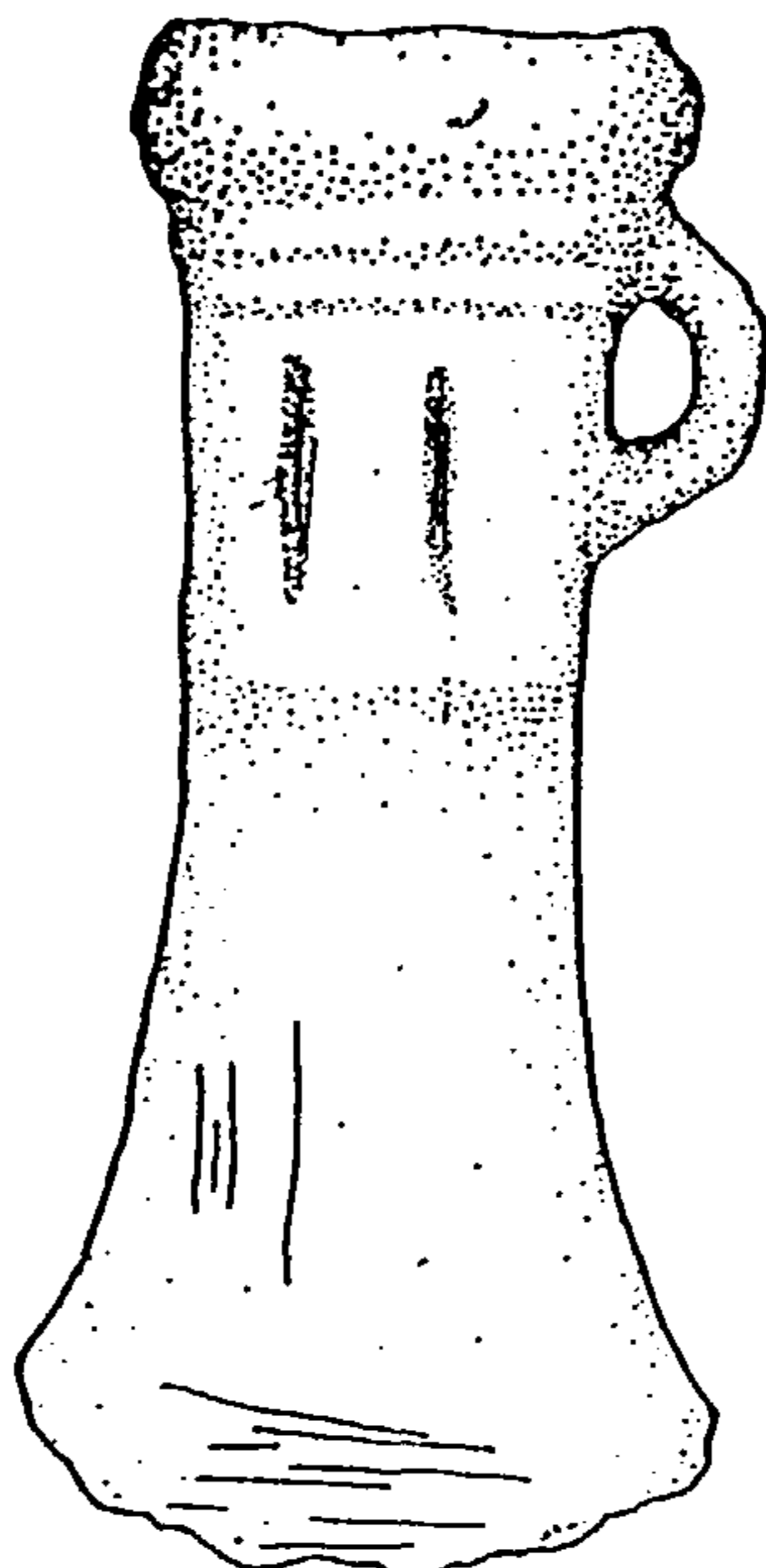
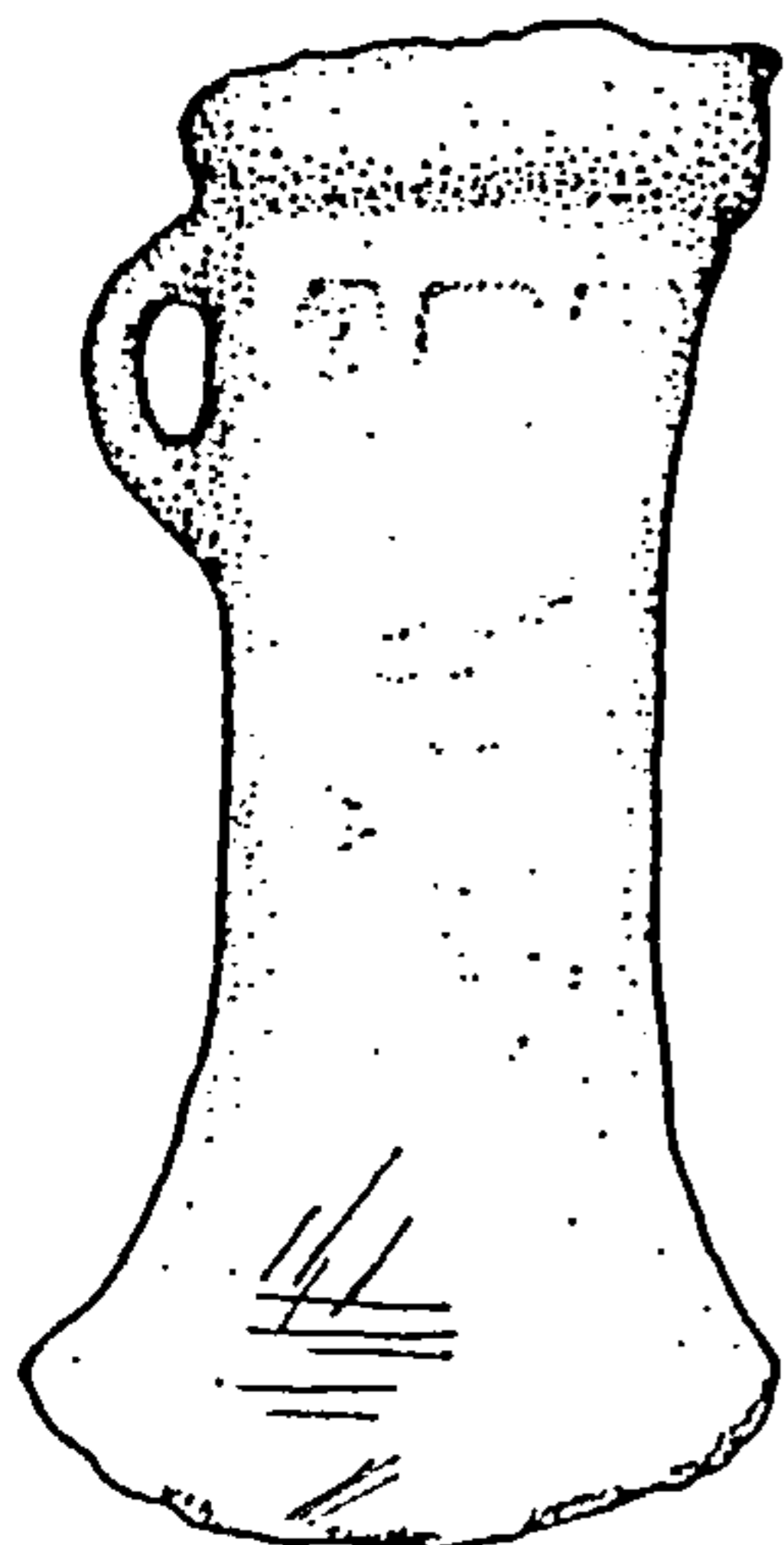
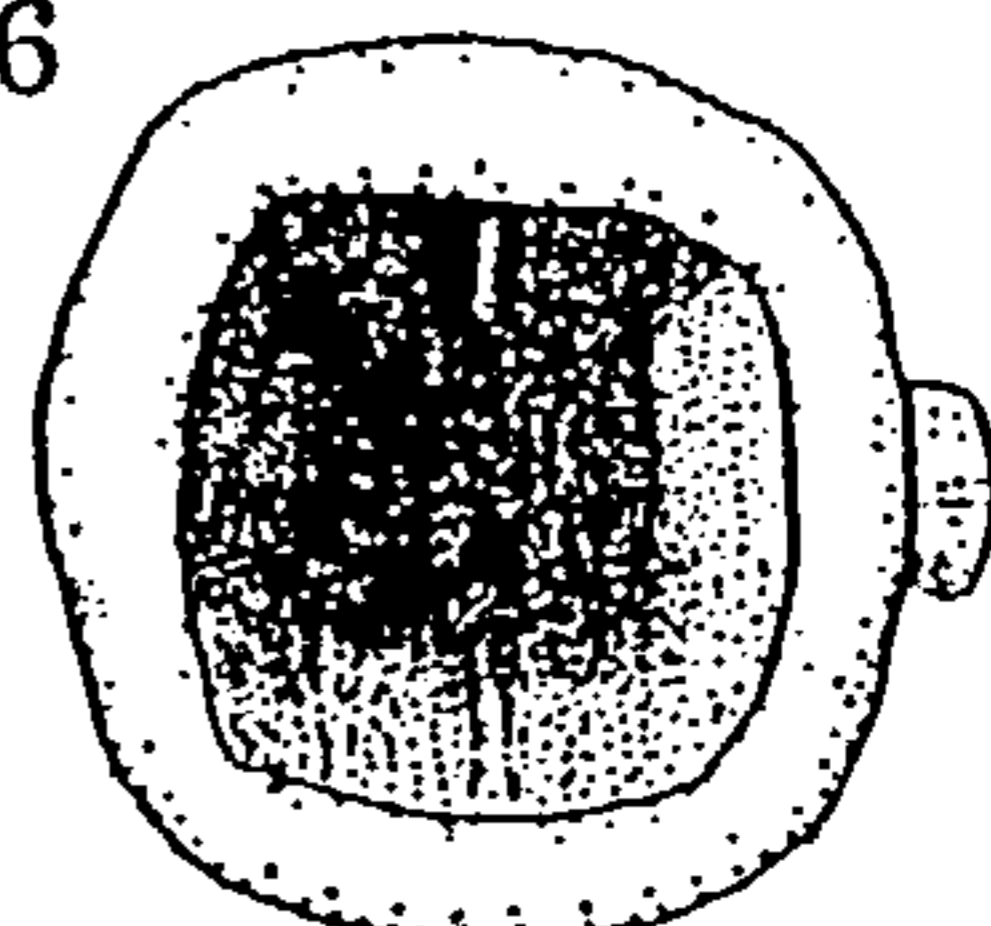
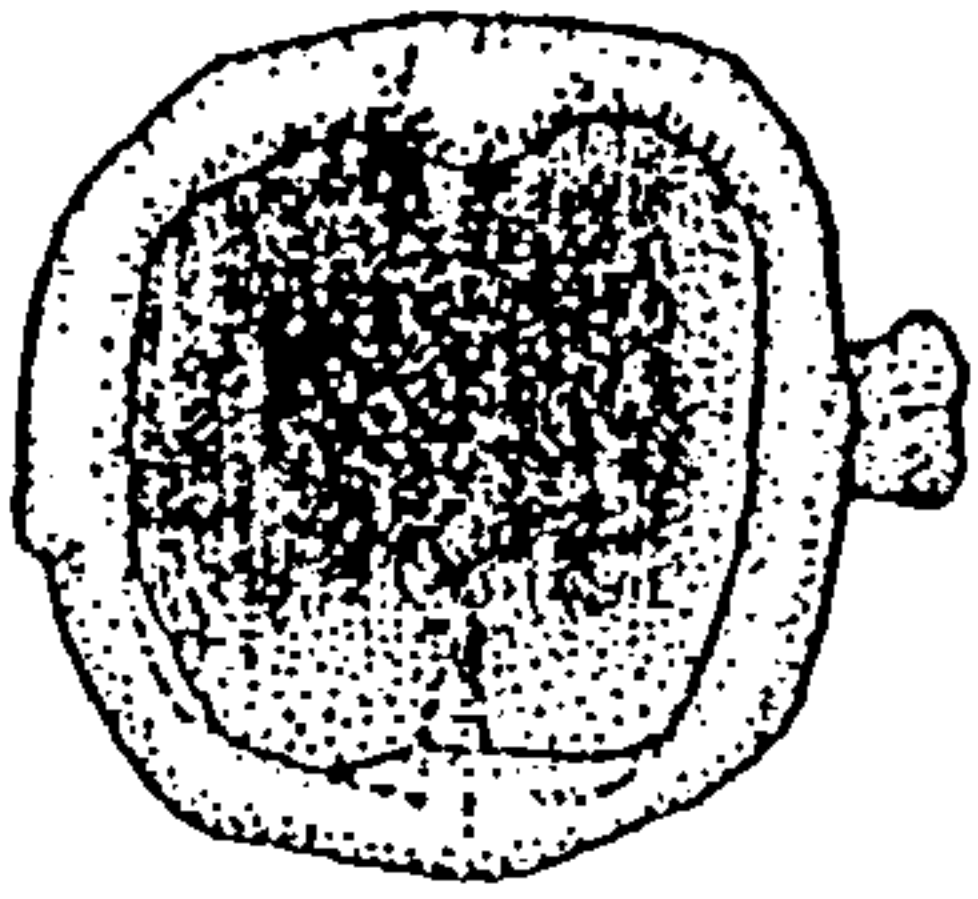
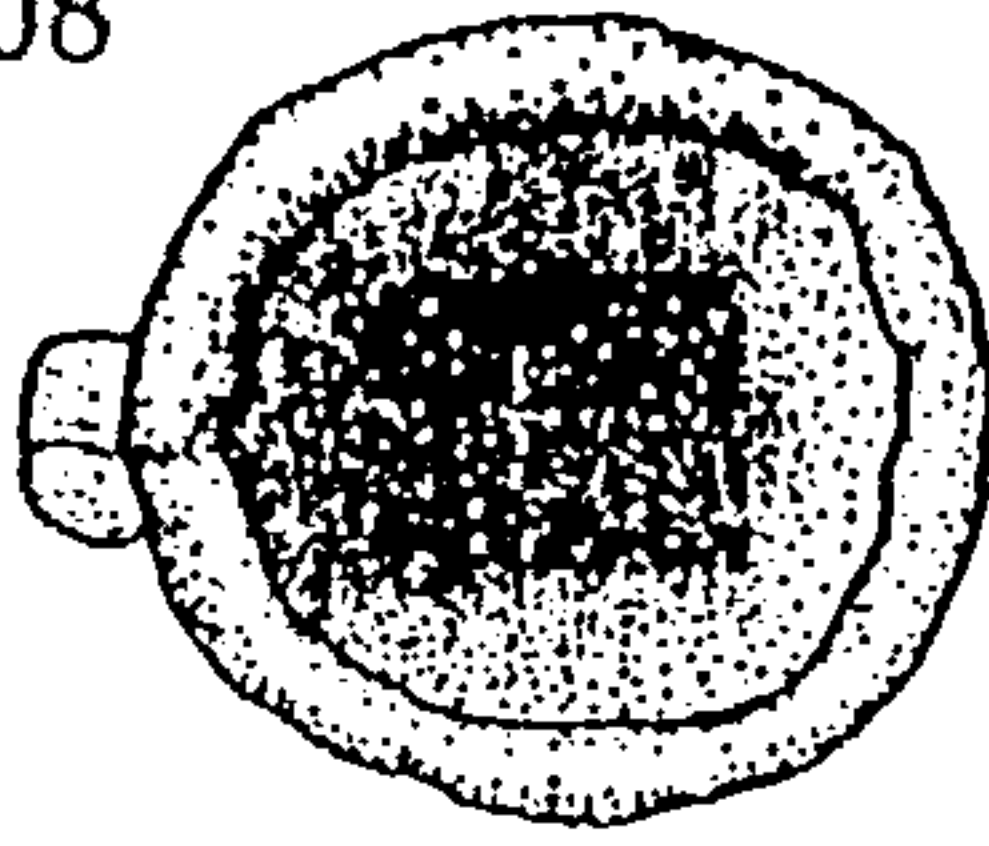


Fig. 13 The Bexley Heath Hoard (Ref. No. 15): Complete Socketed Axes (i)

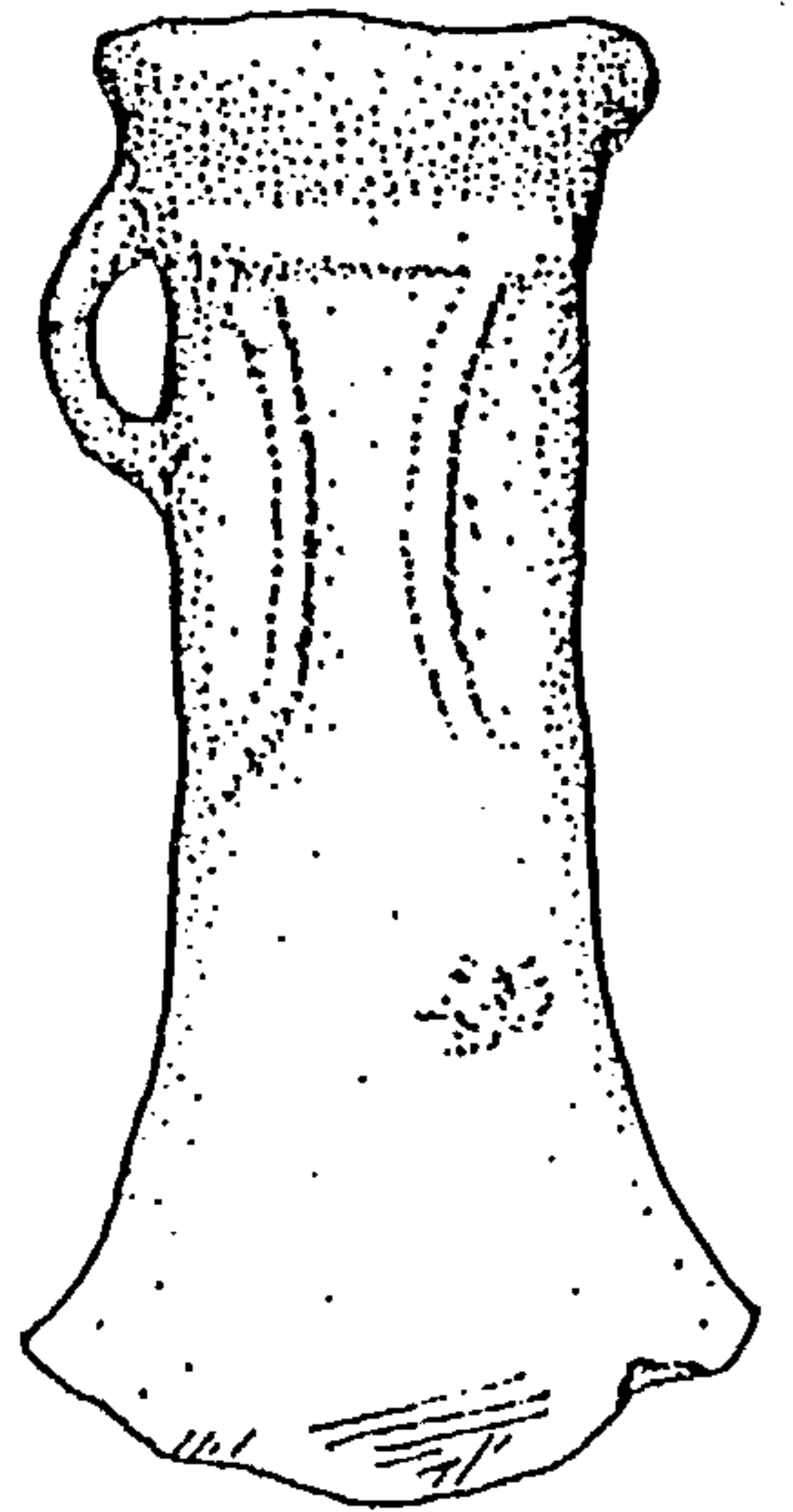
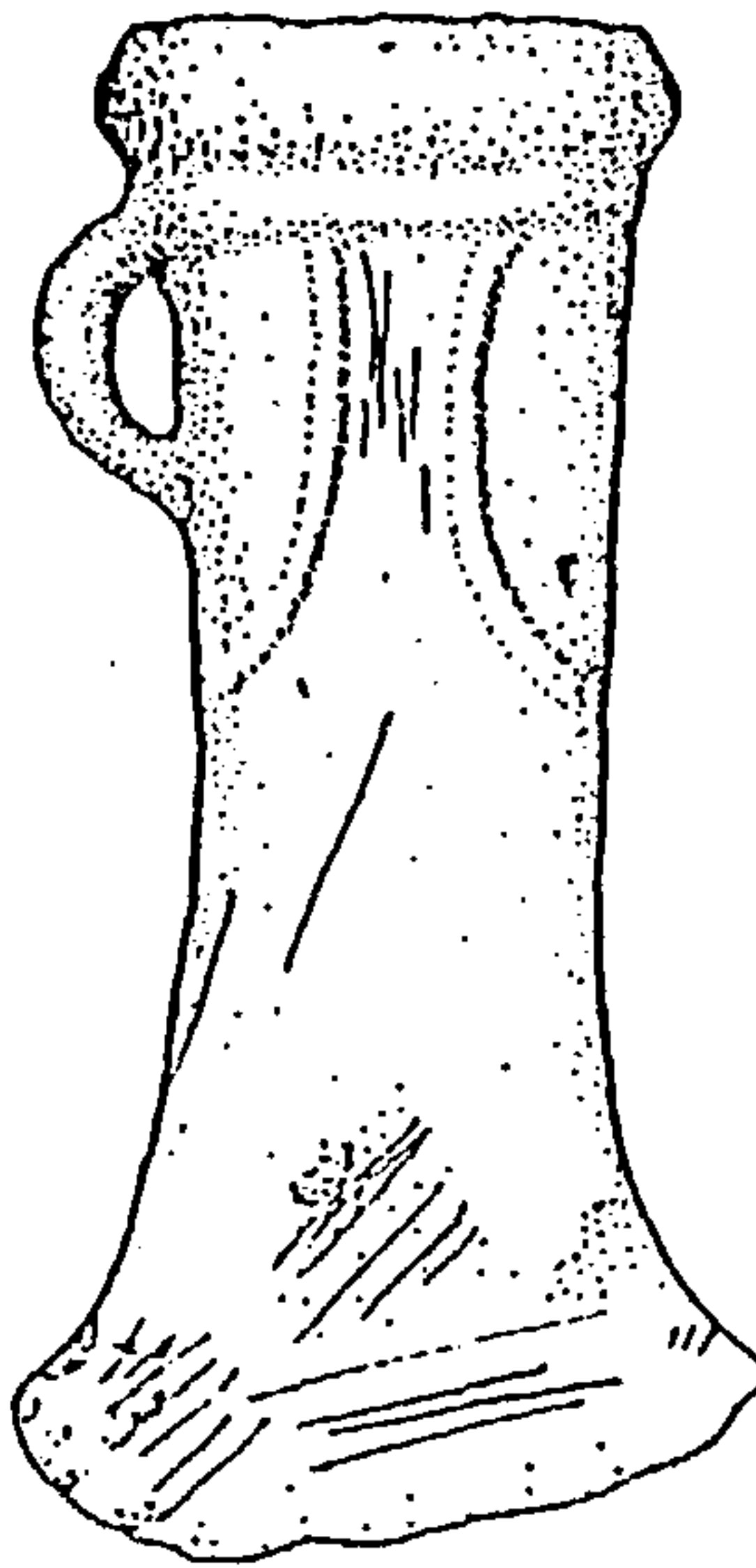
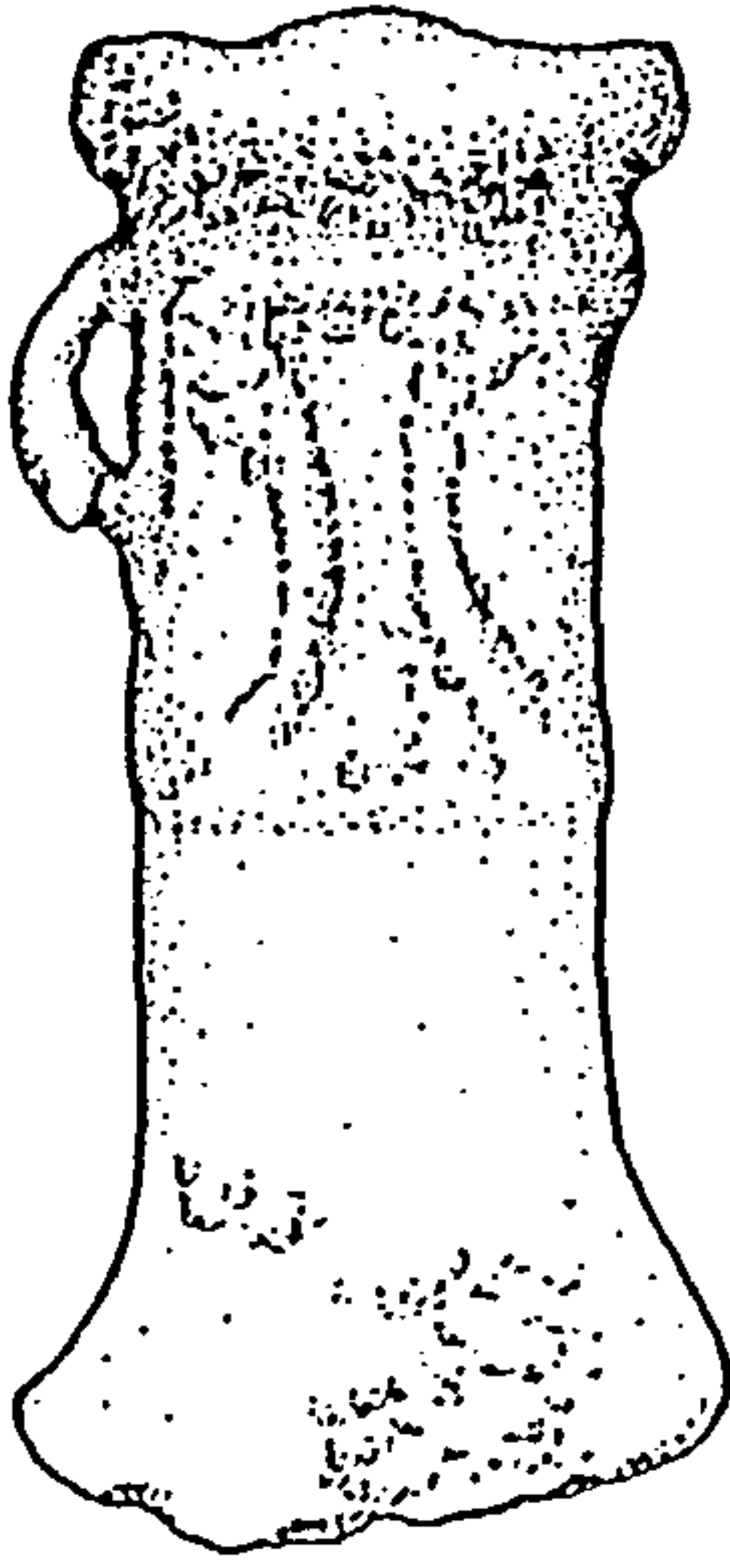
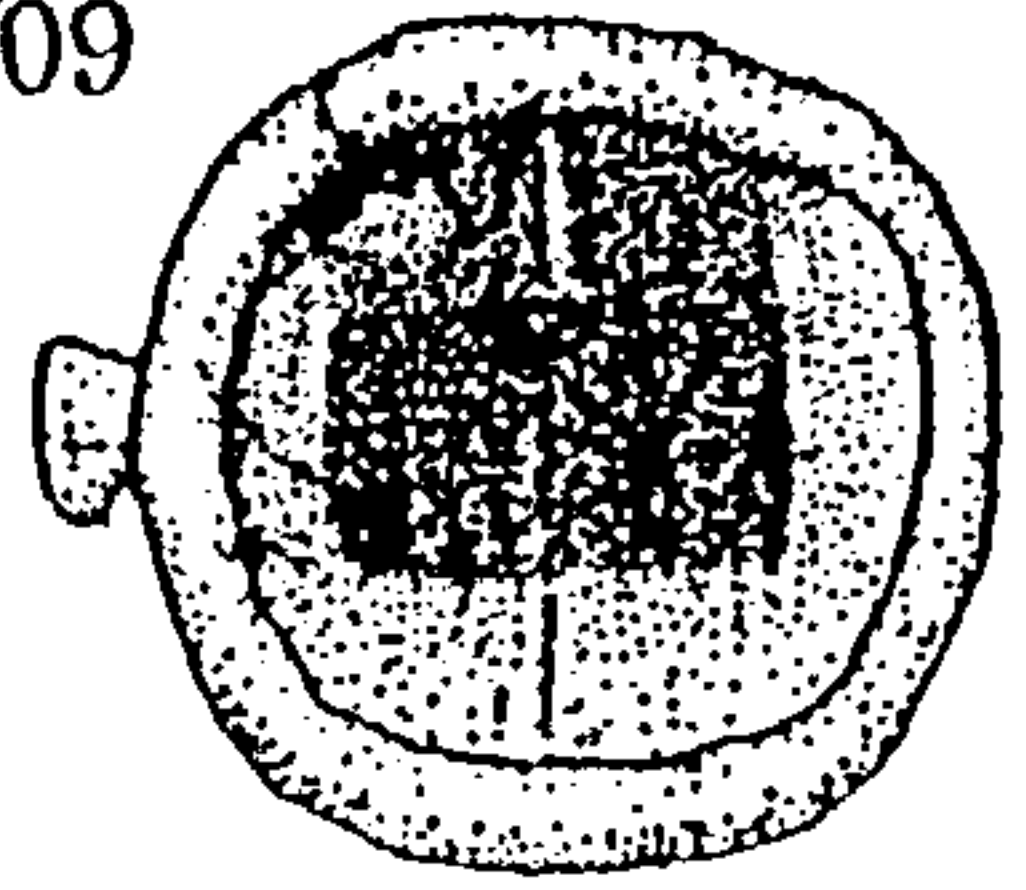
15/07



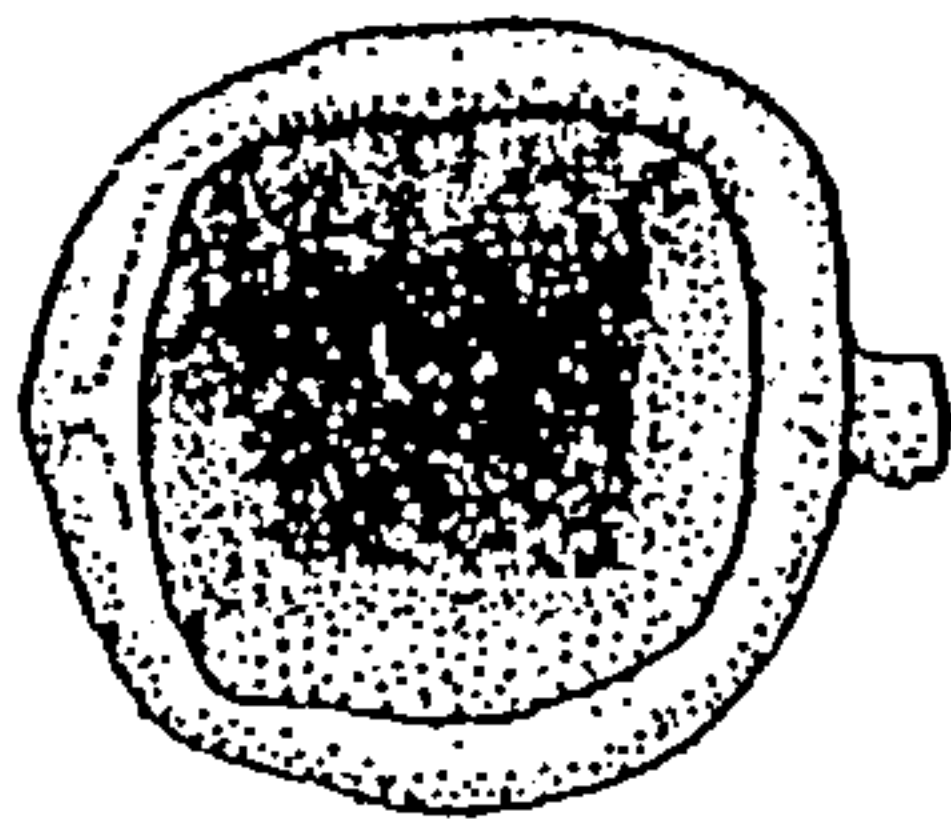
15/08



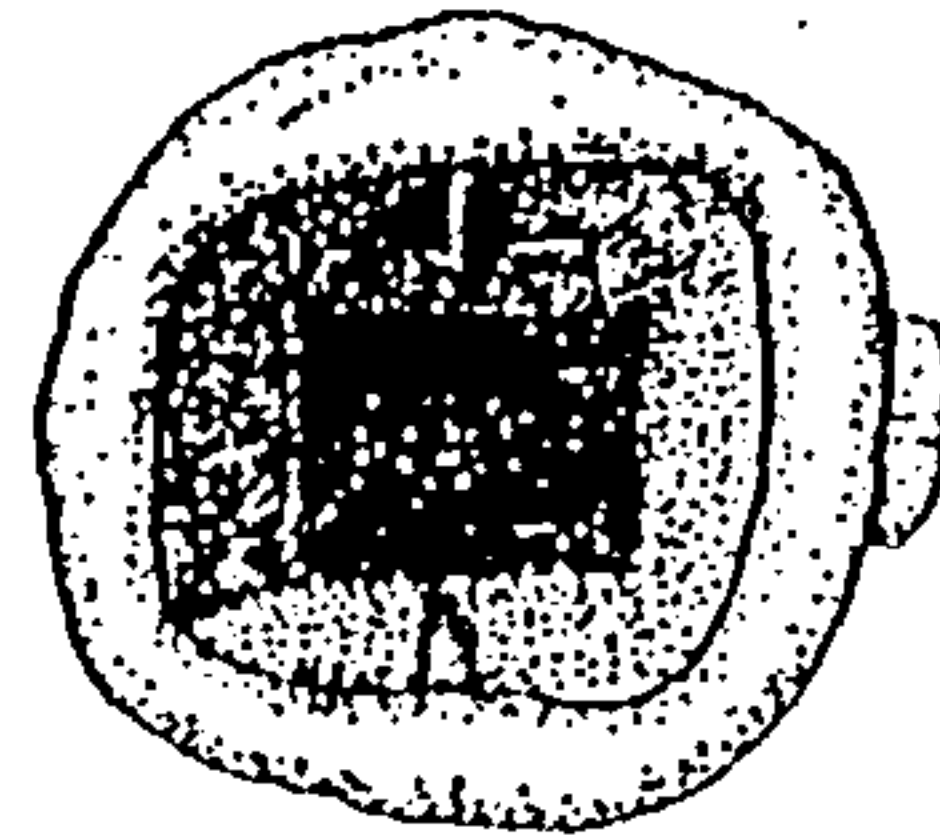
15/09



15/10



15/11



0 2cm

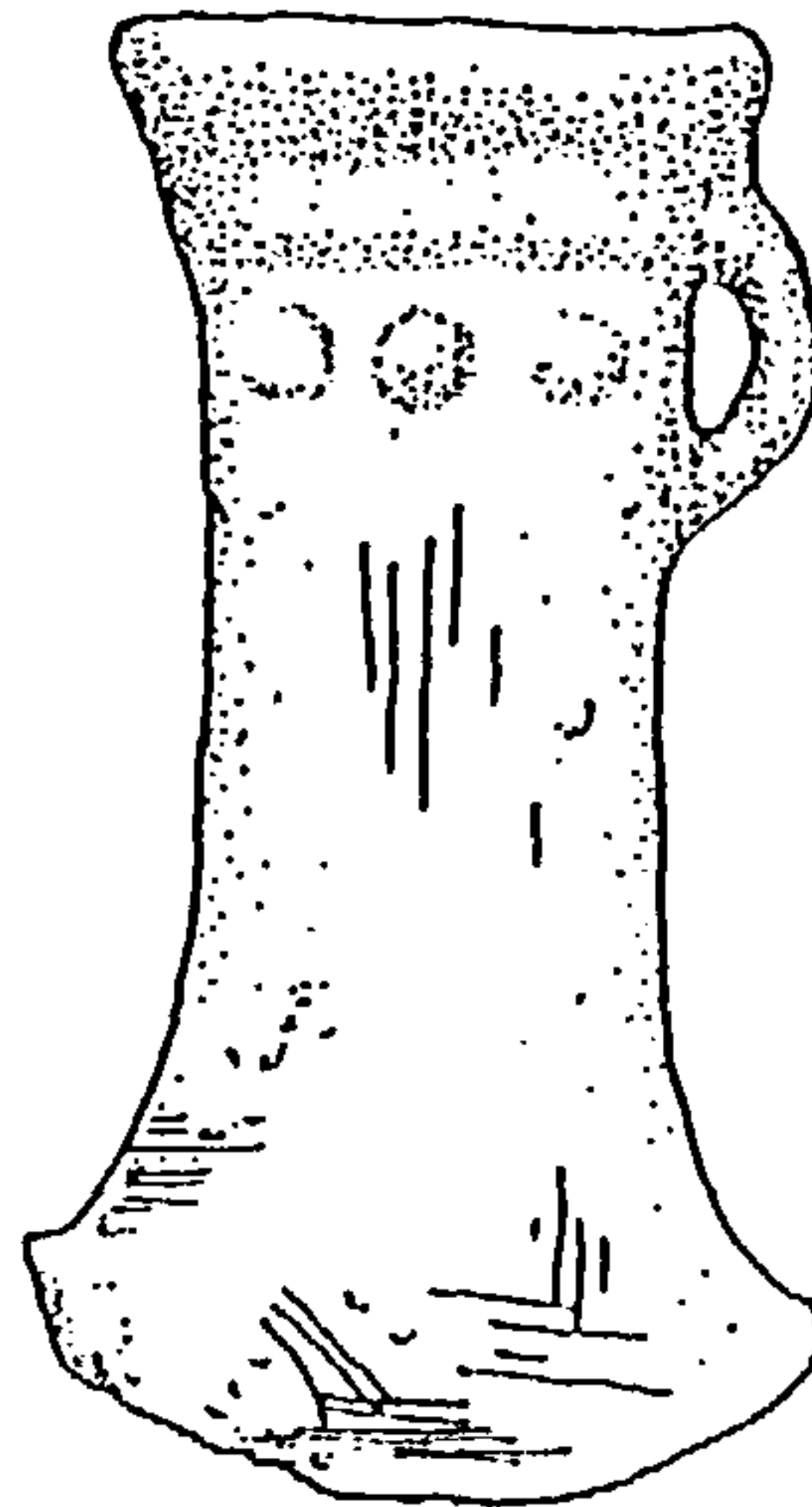
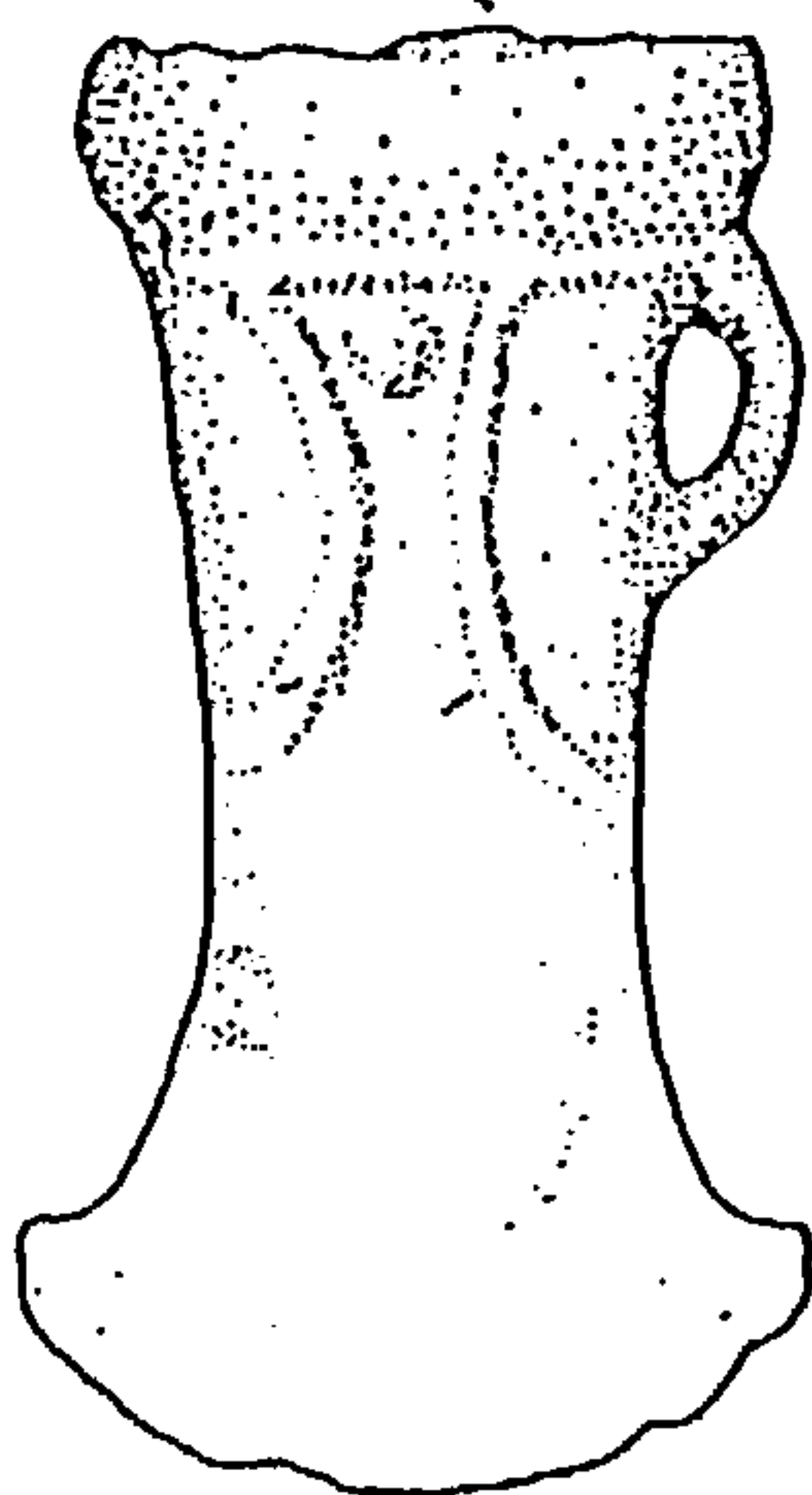
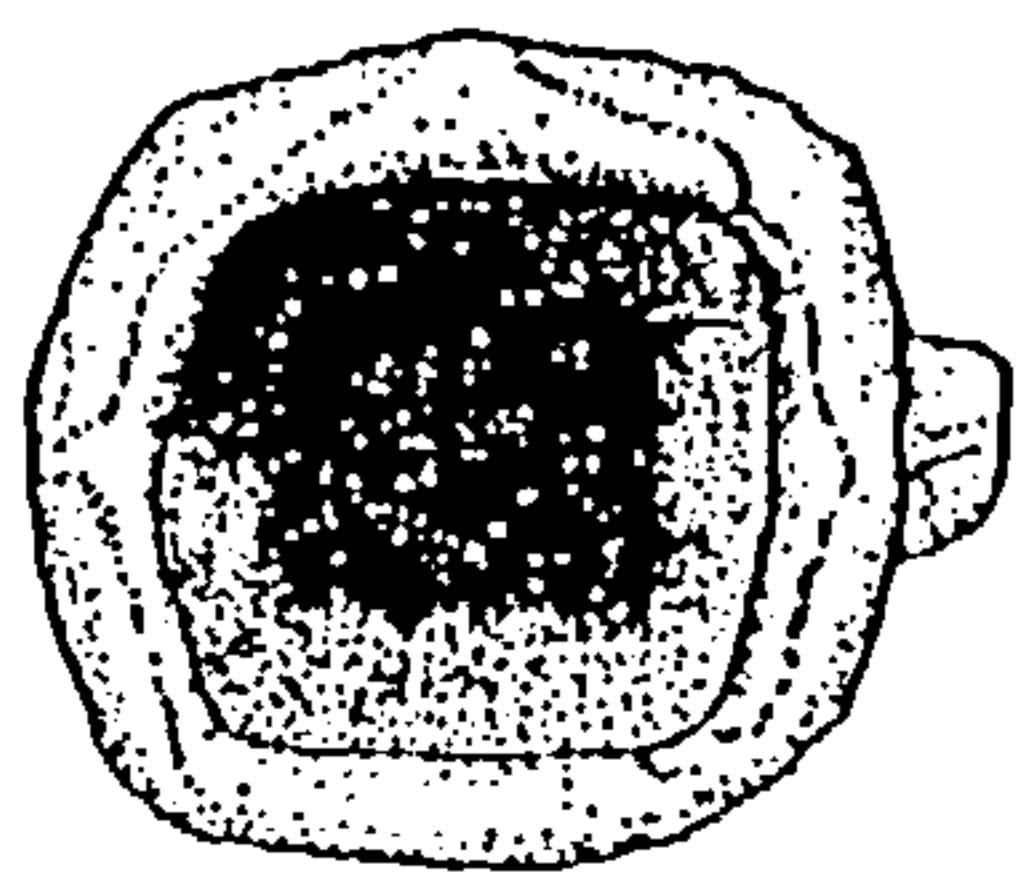
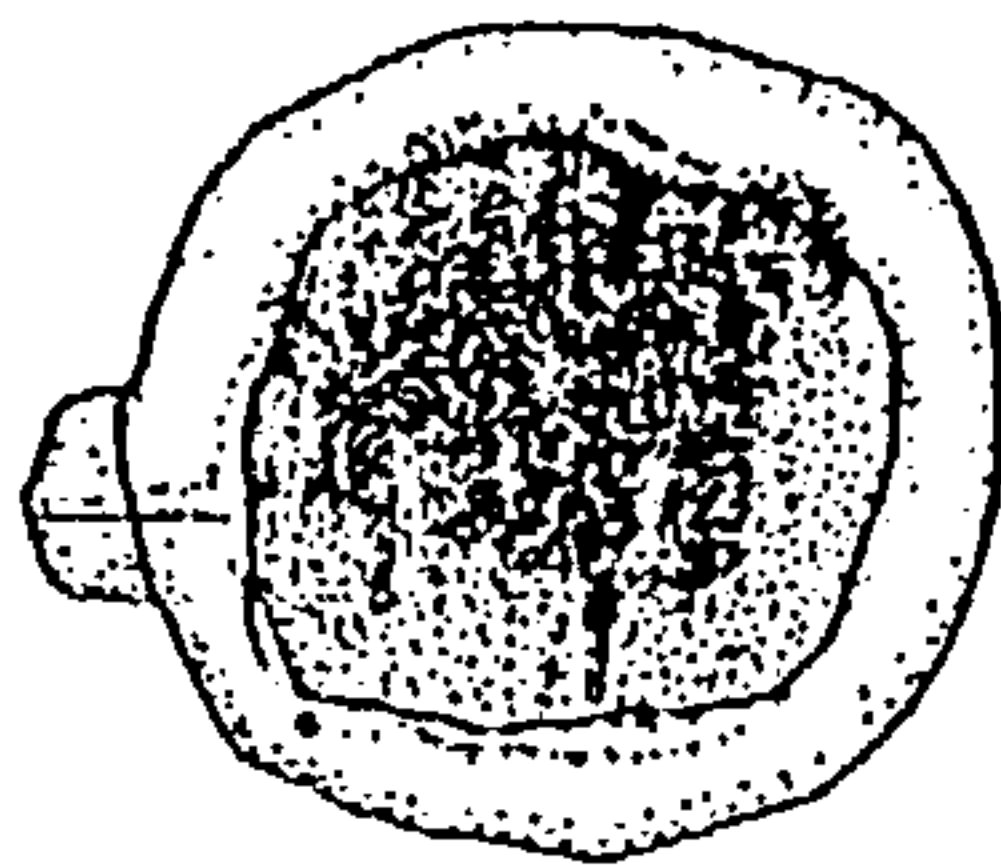


Fig. 14 The Bexley Heath Hoard (Ref. No. 15): Complete Socketed Axes (ii)

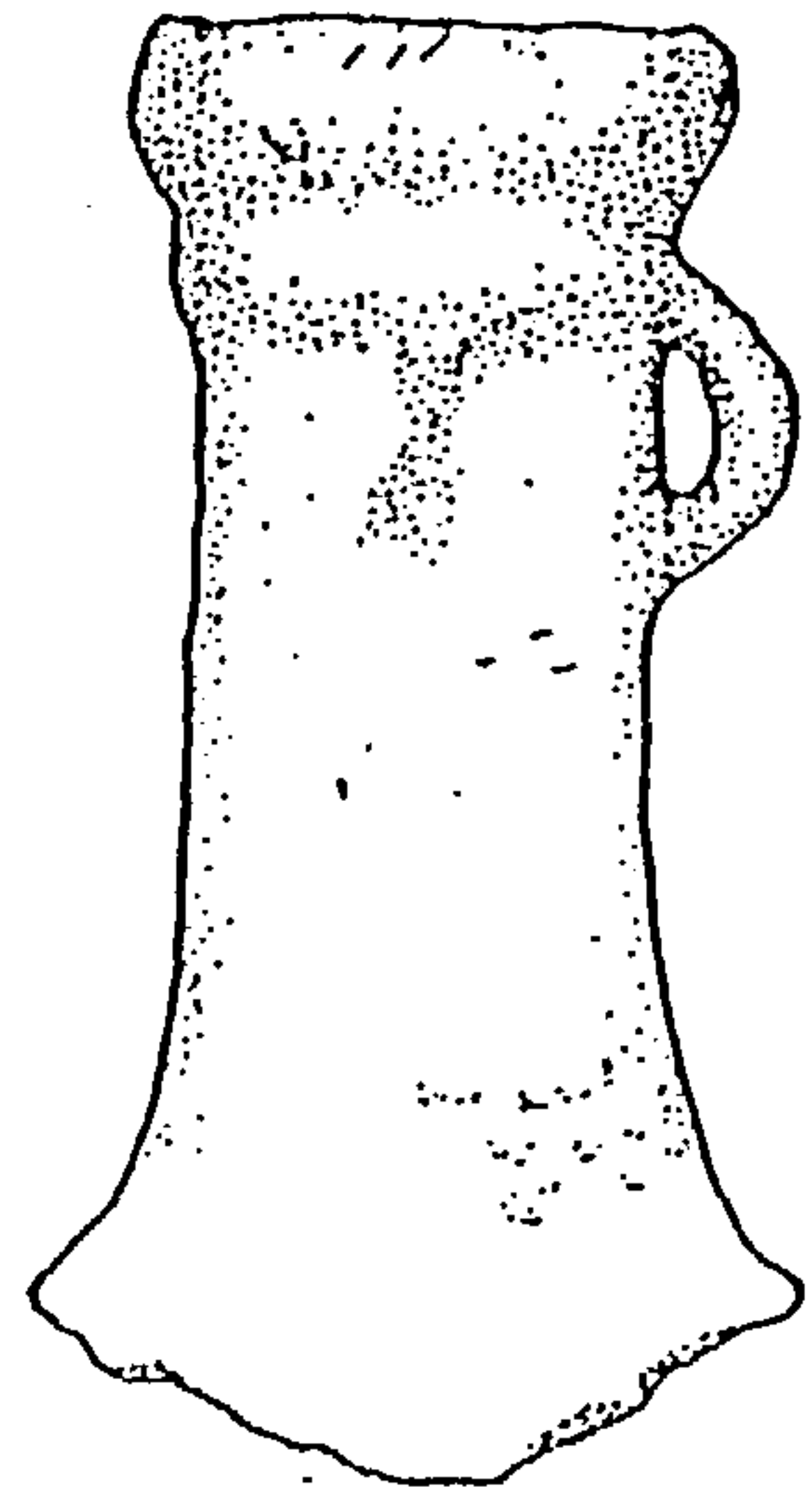
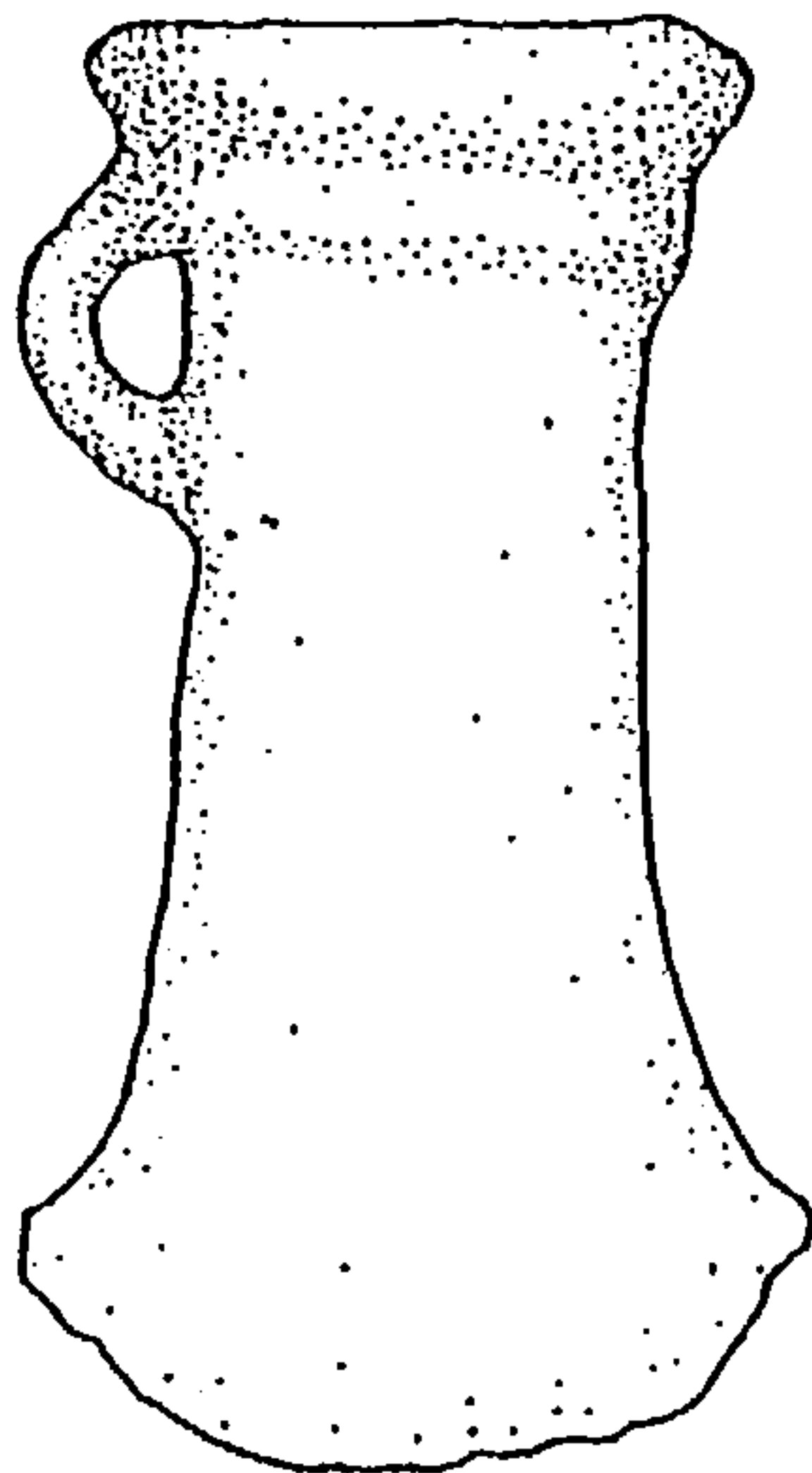
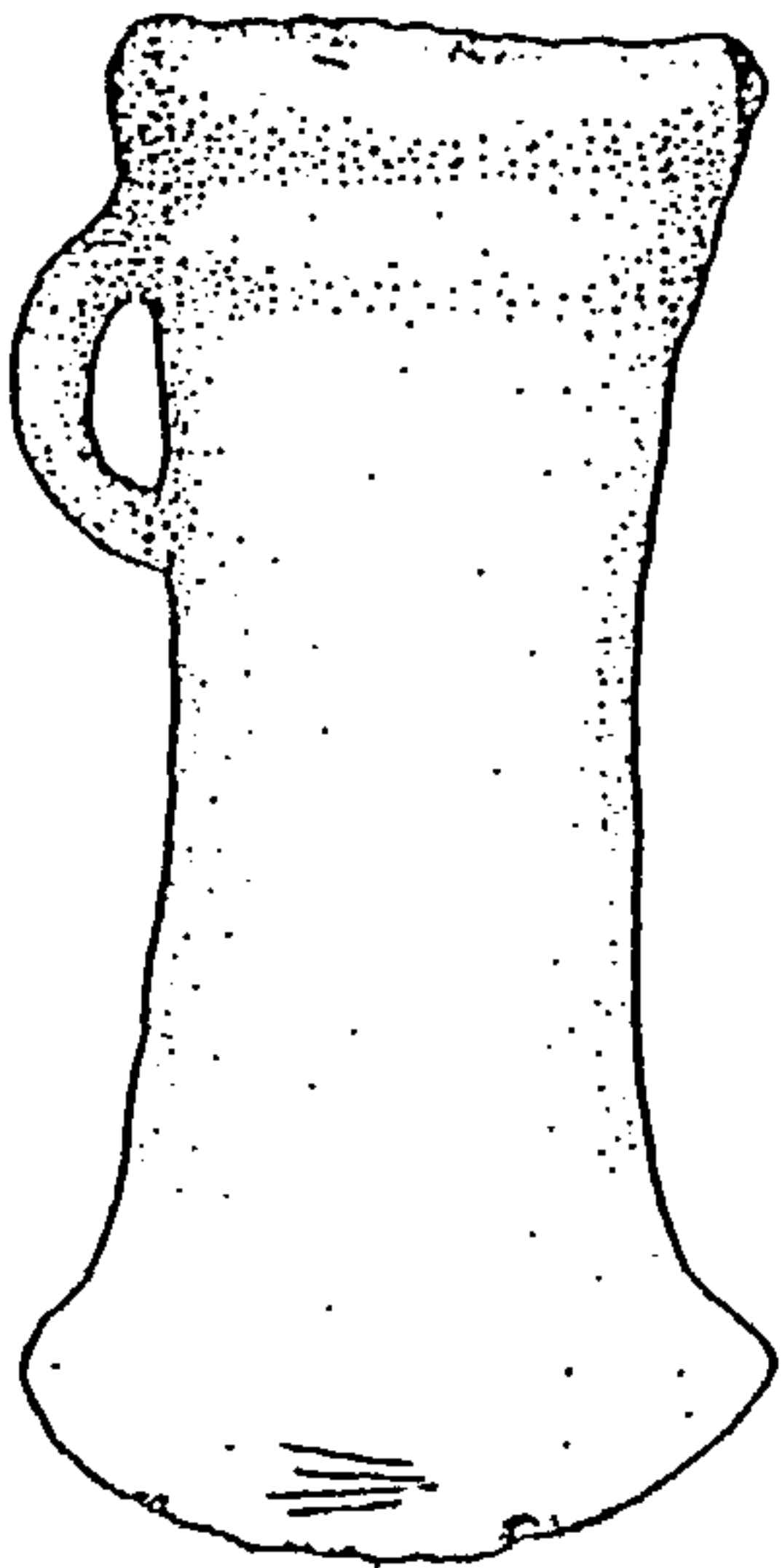
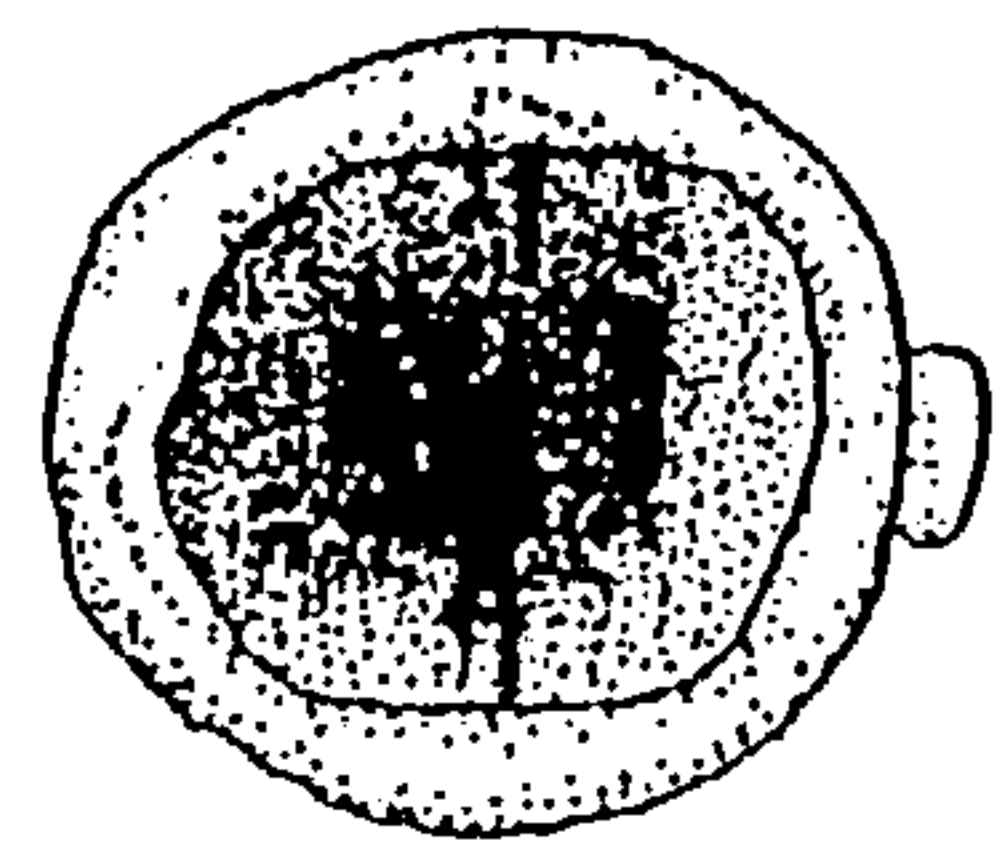
15/12



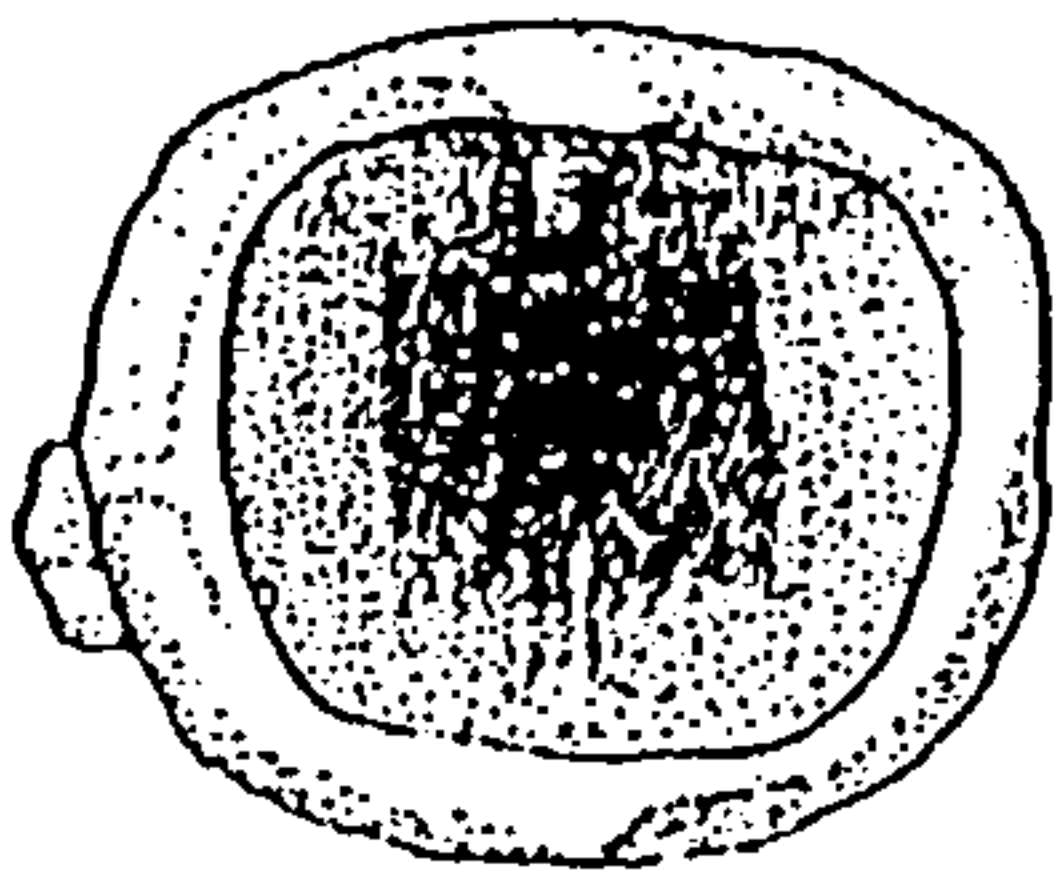
15/13



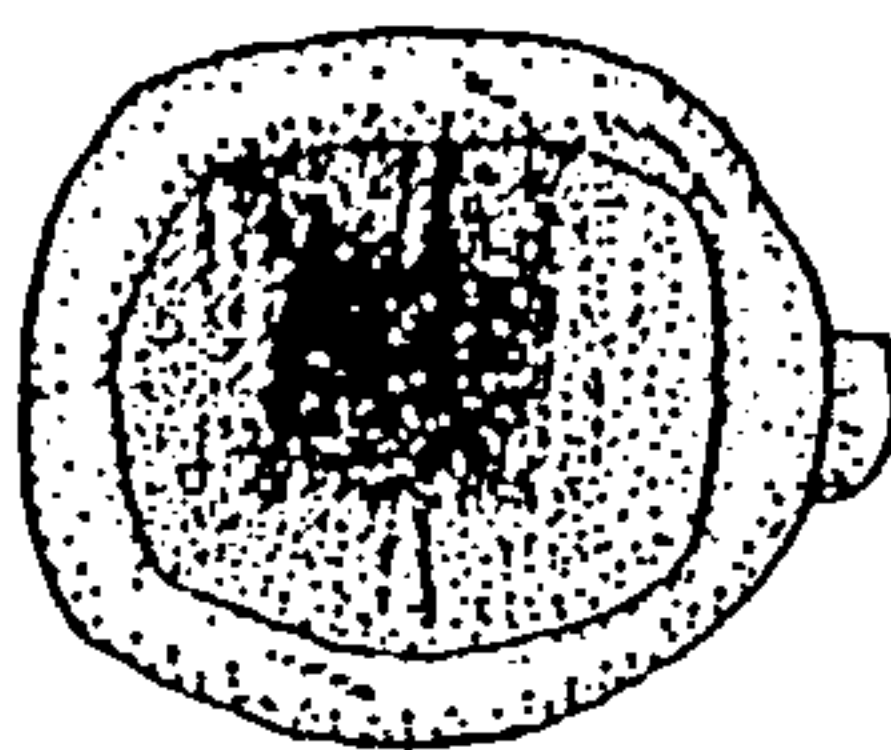
15/14



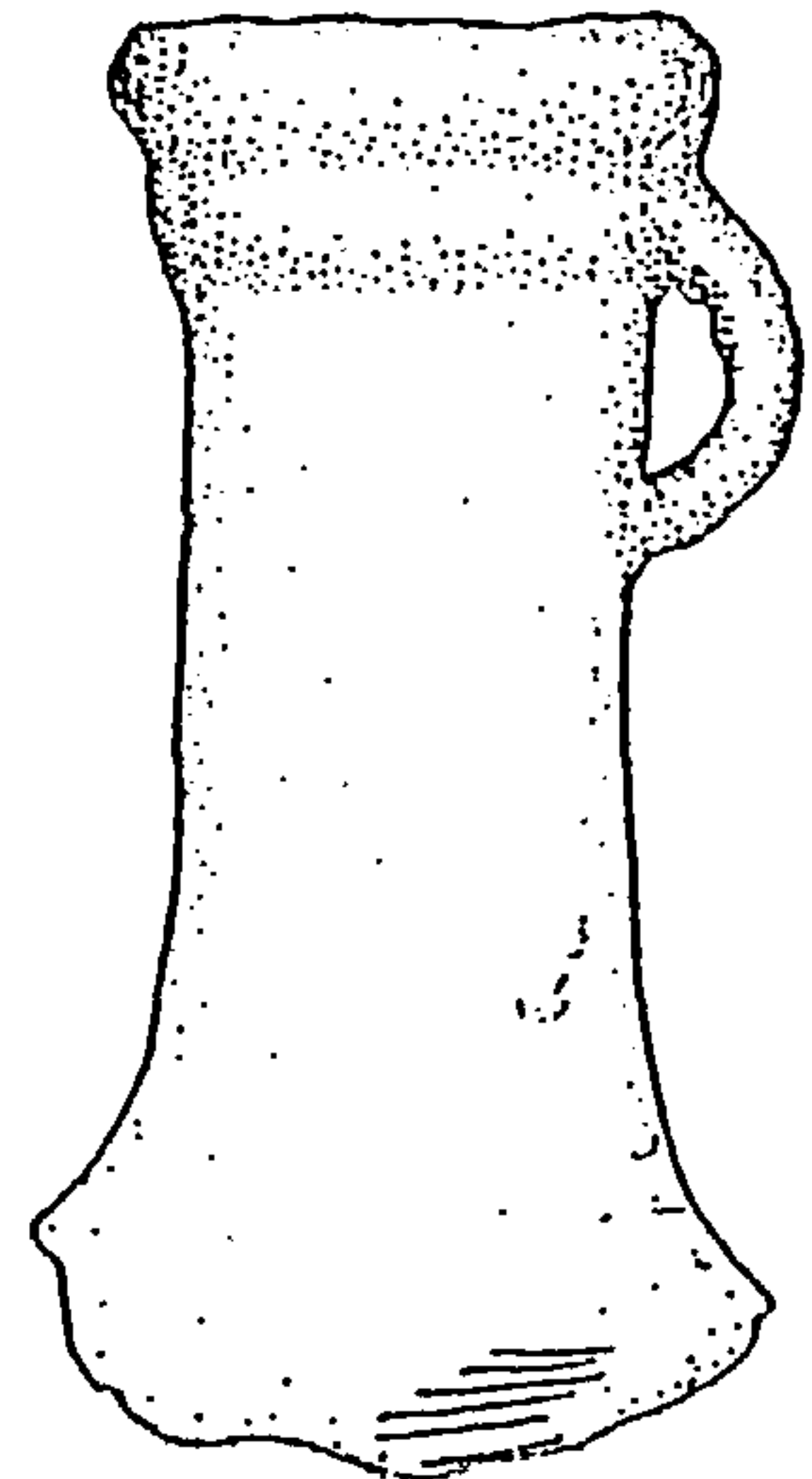
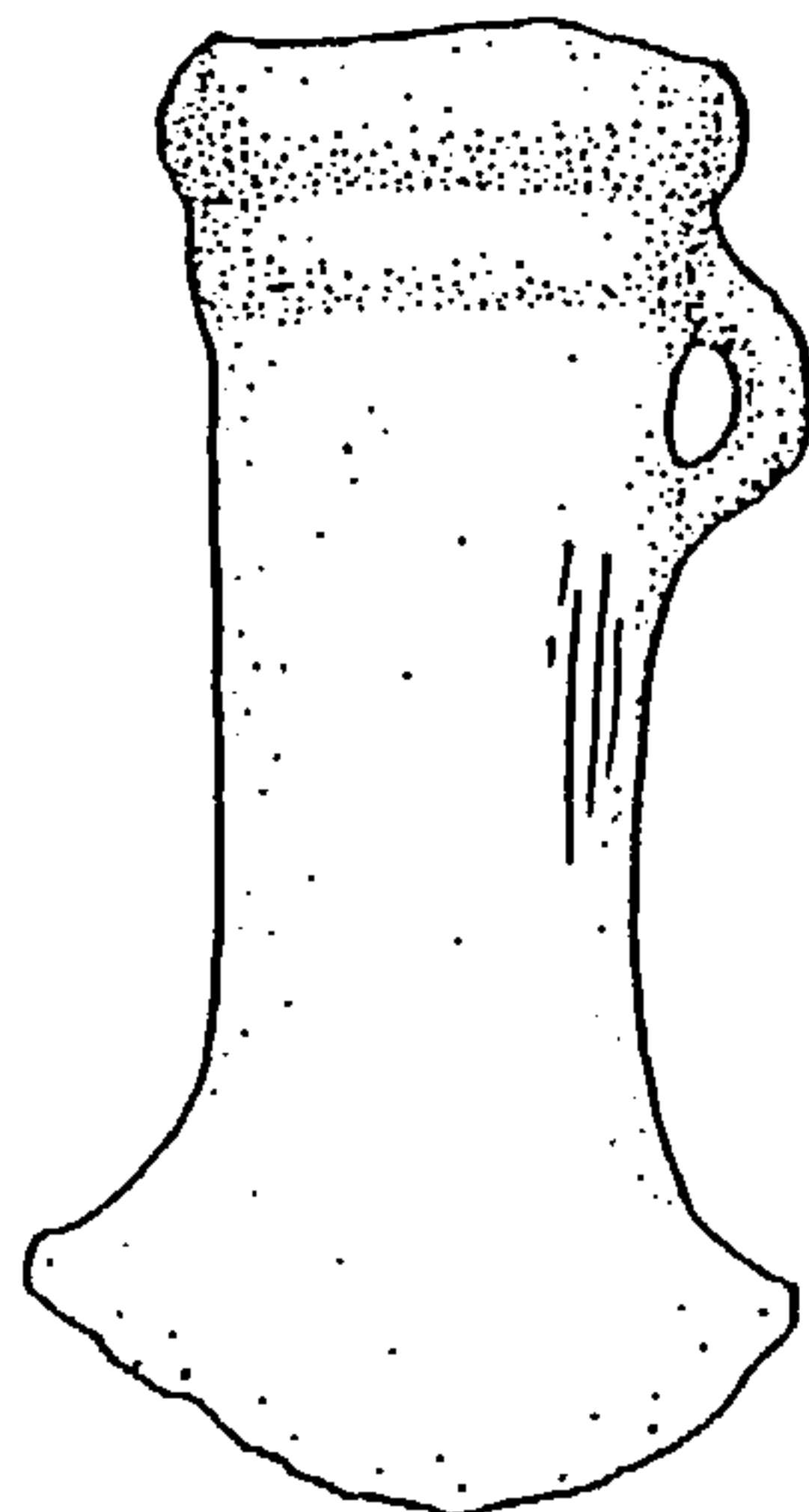
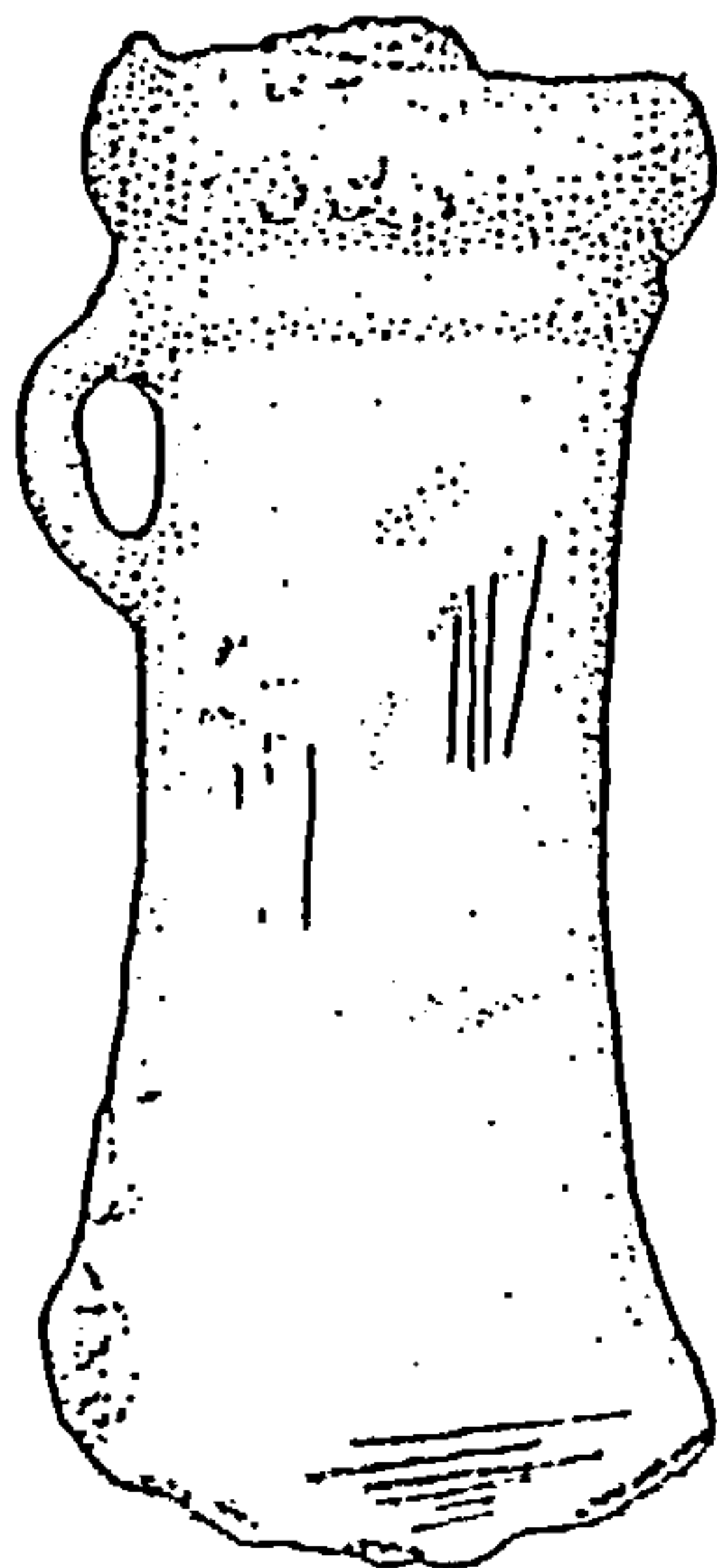
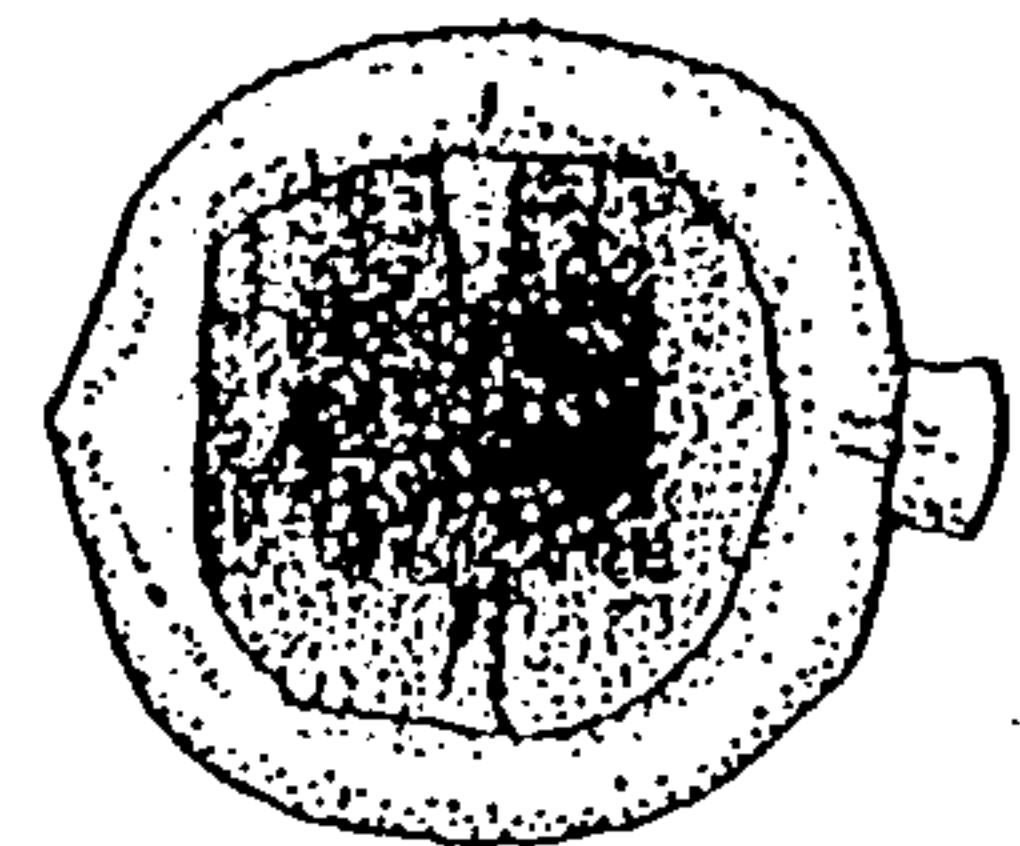
15/15



15/16



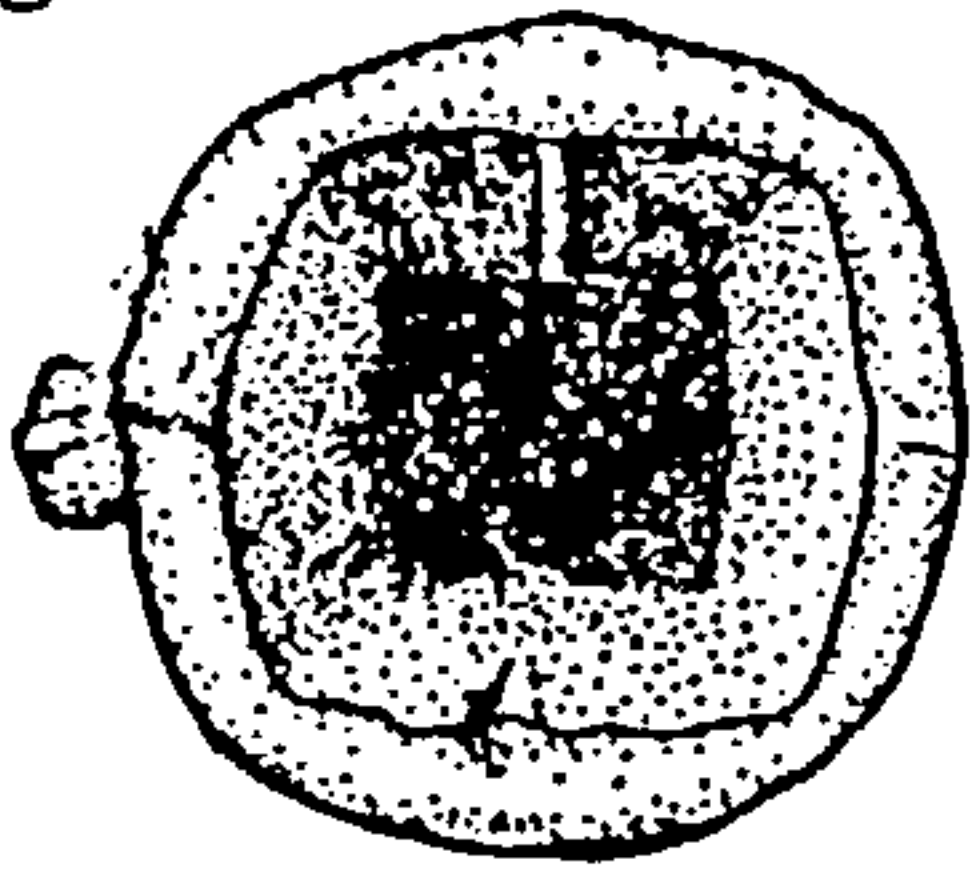
15/17



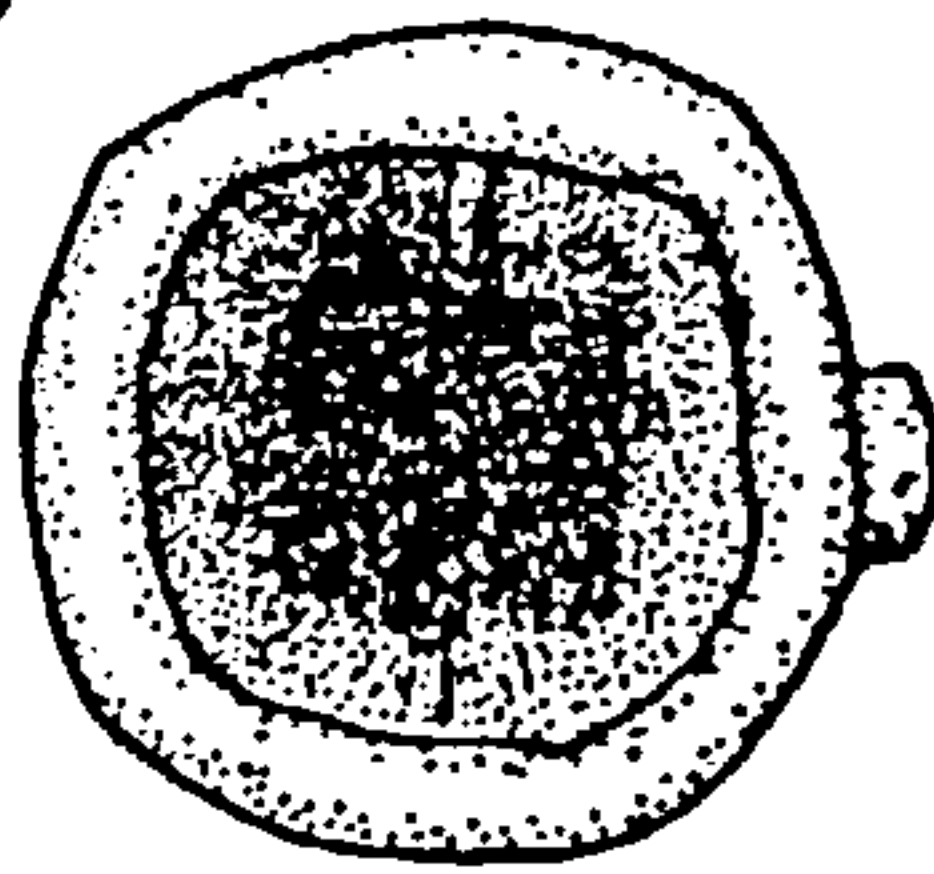
0 2cm

Fig. 15 The Bexley Heath Hoard (Ref. No. 15): Complete Socketed Axes (iii)

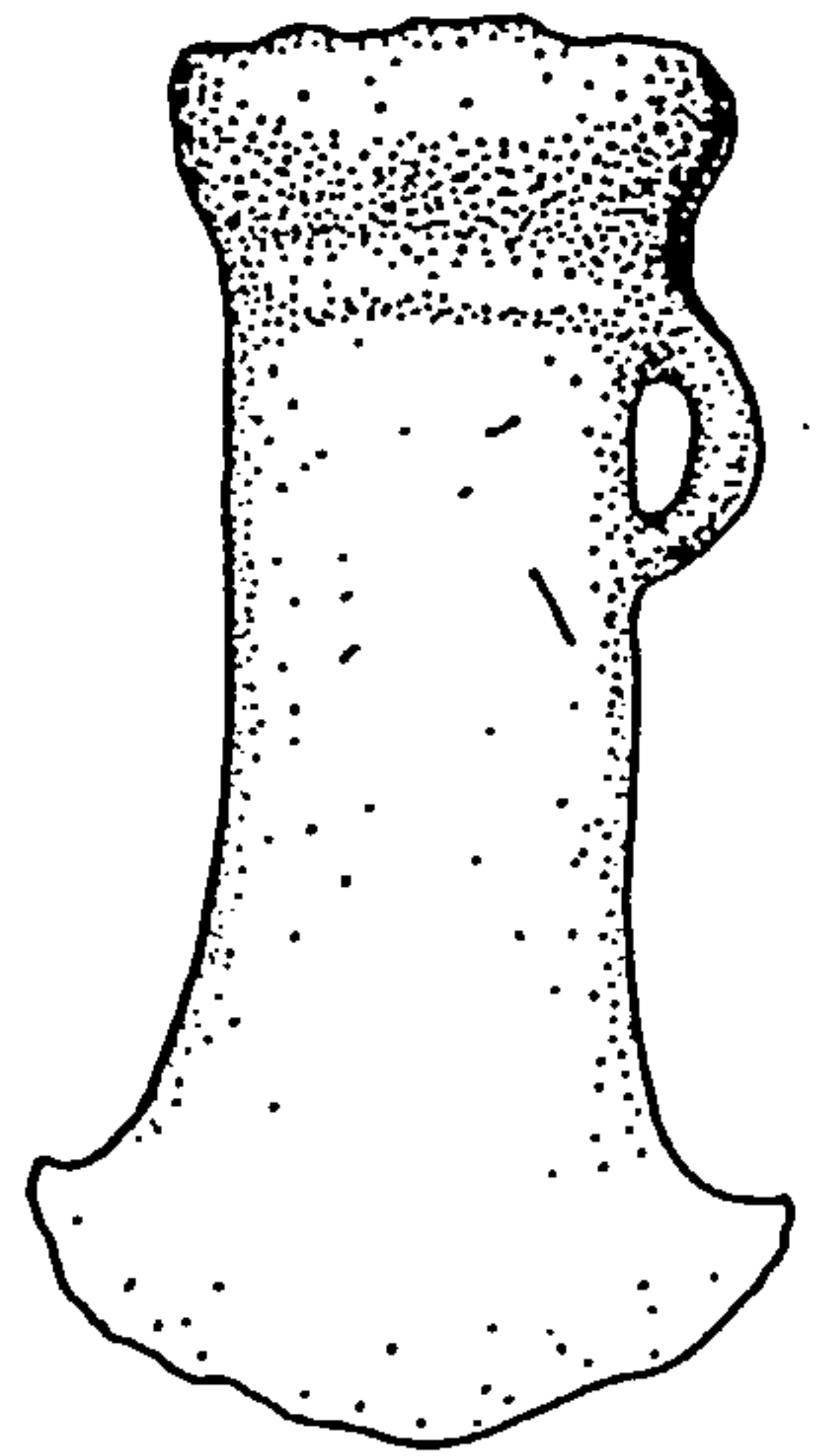
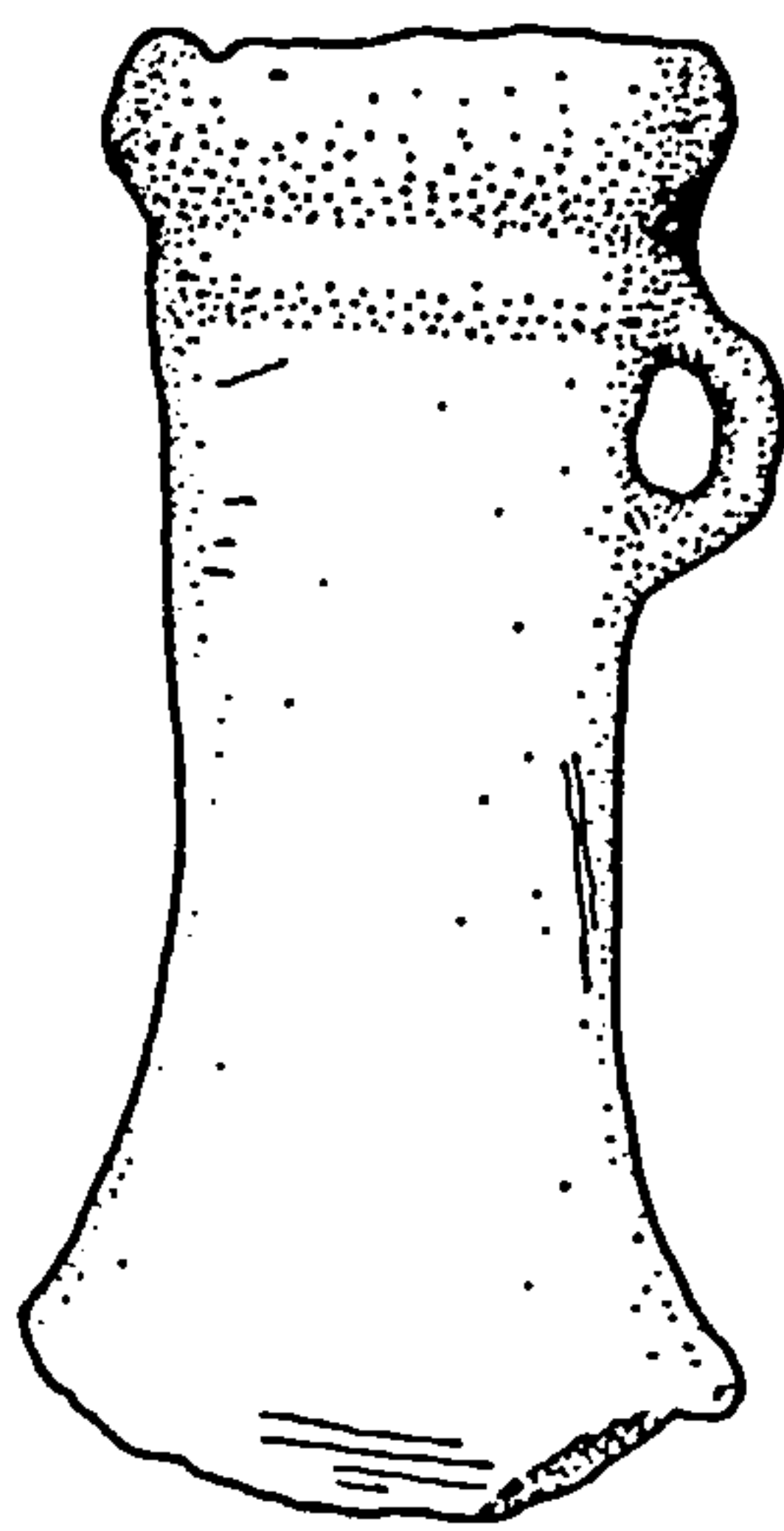
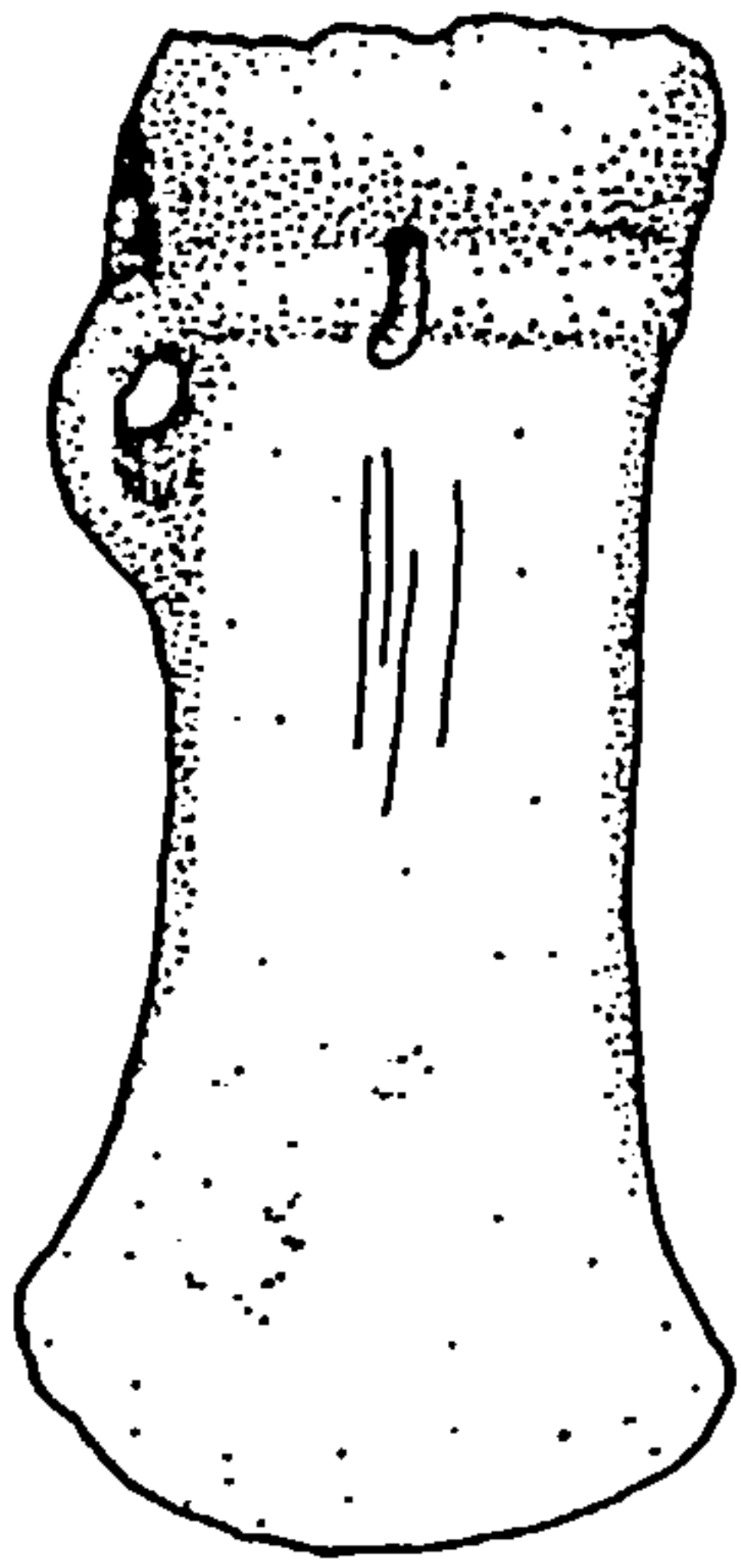
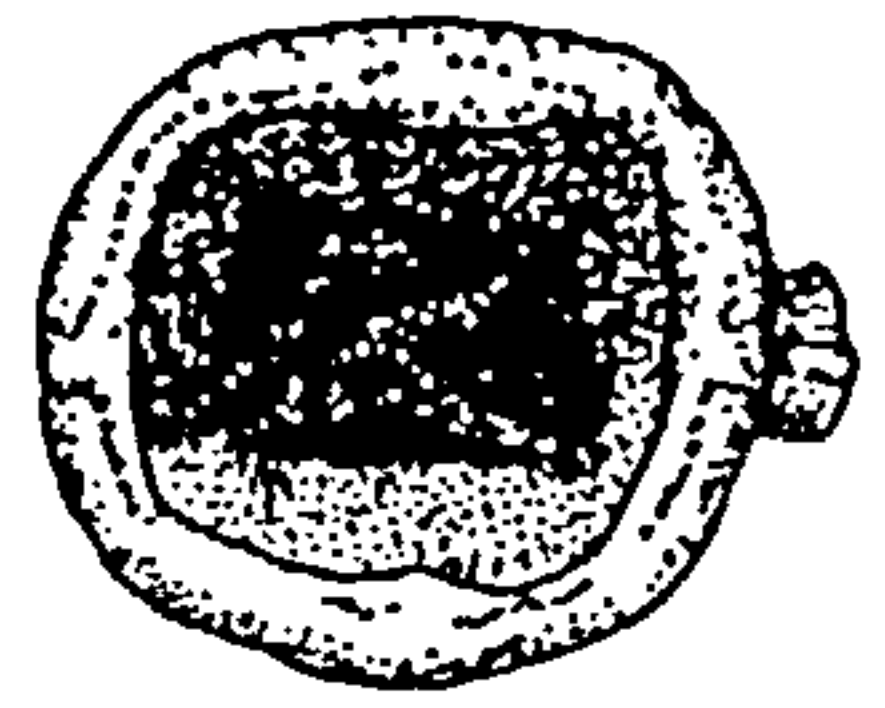
15/18



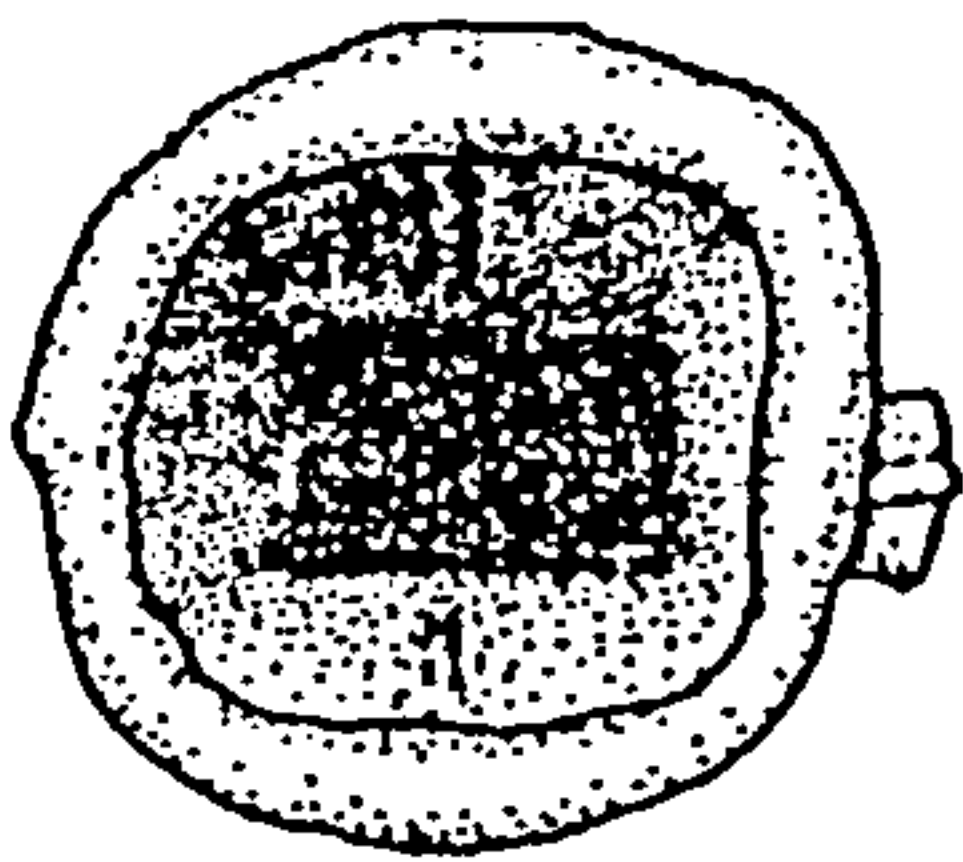
15/19



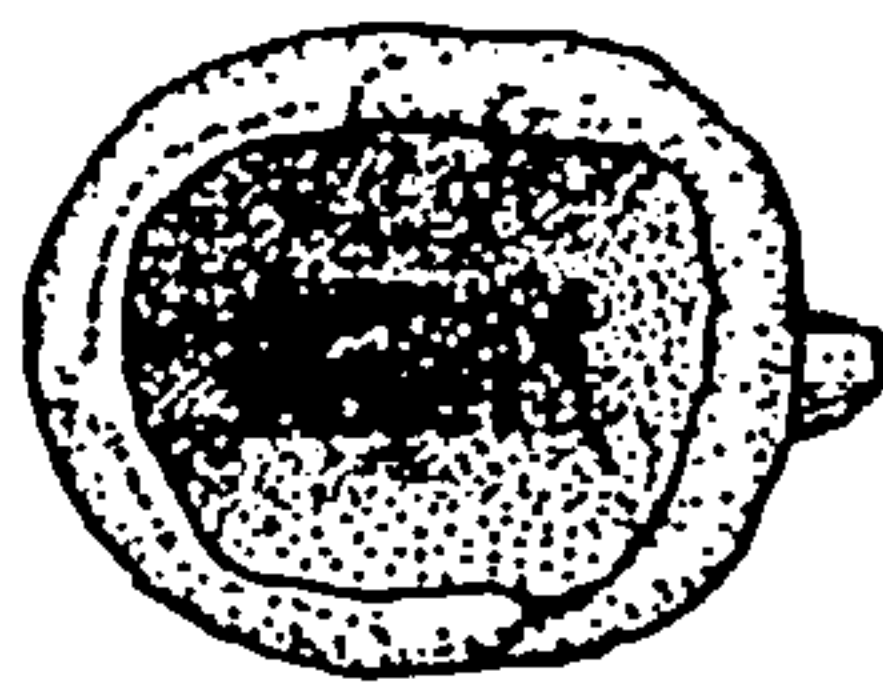
15/20



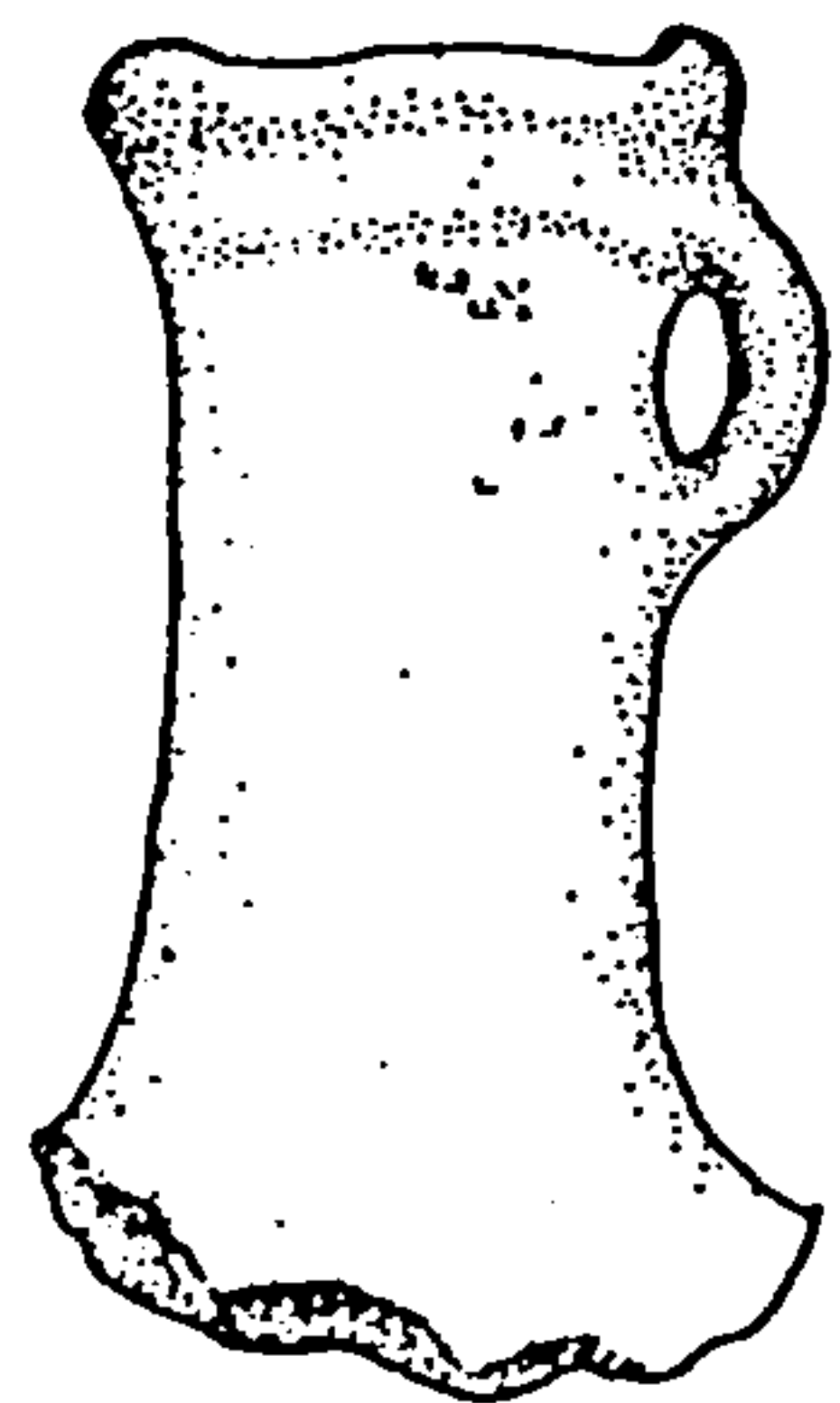
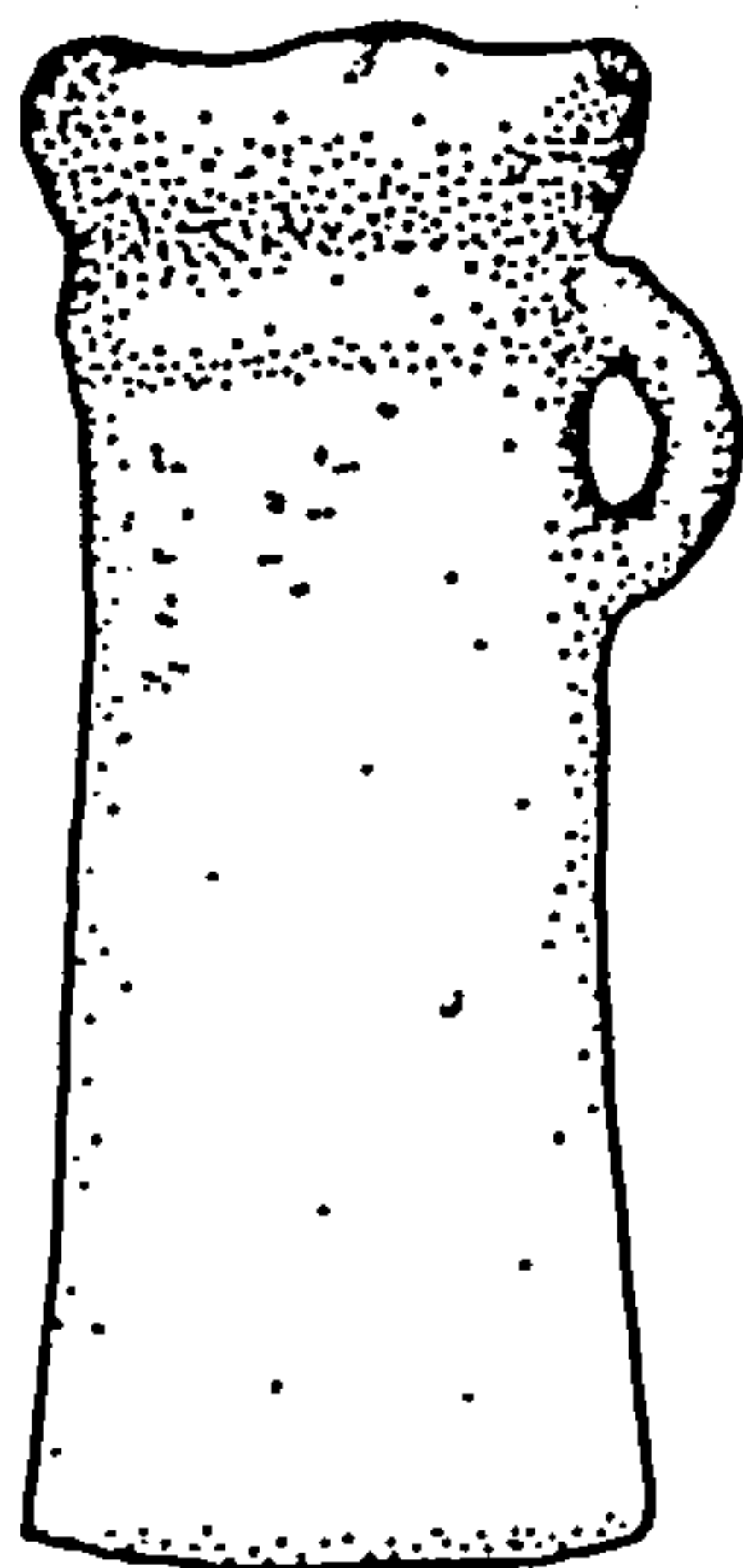
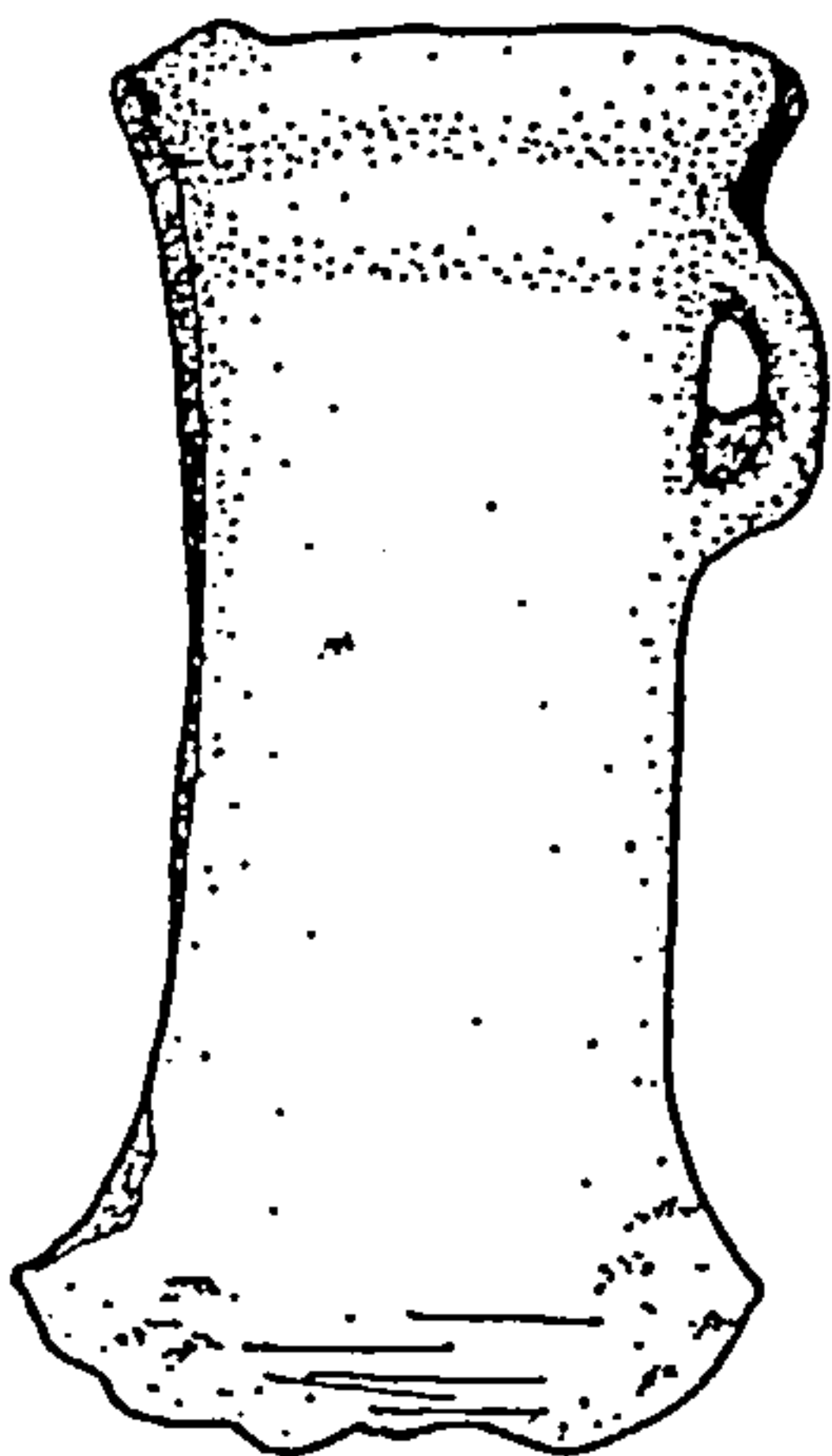
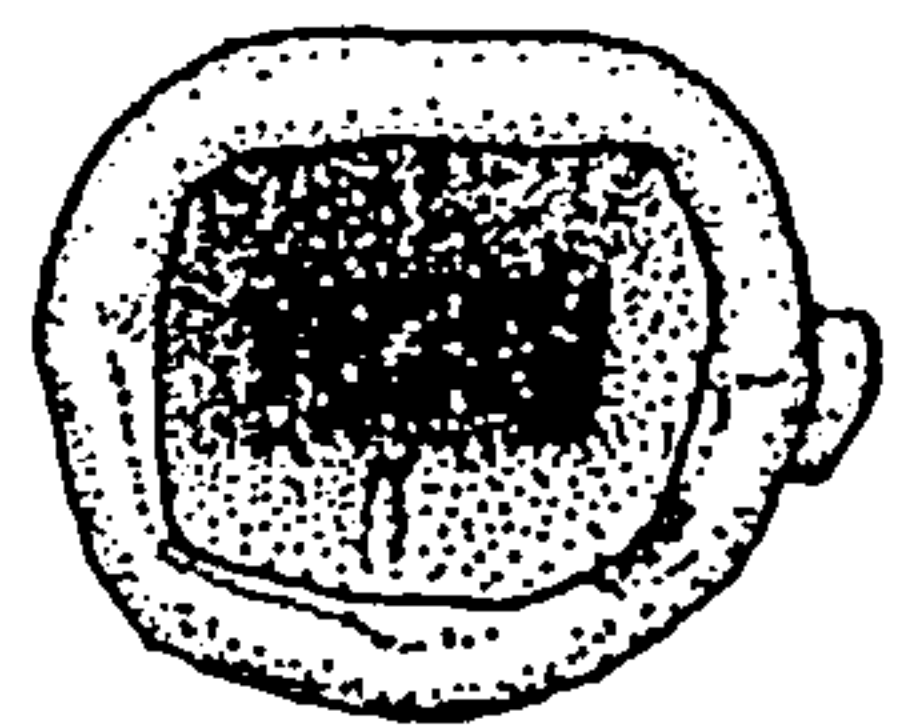
15/21



15/22



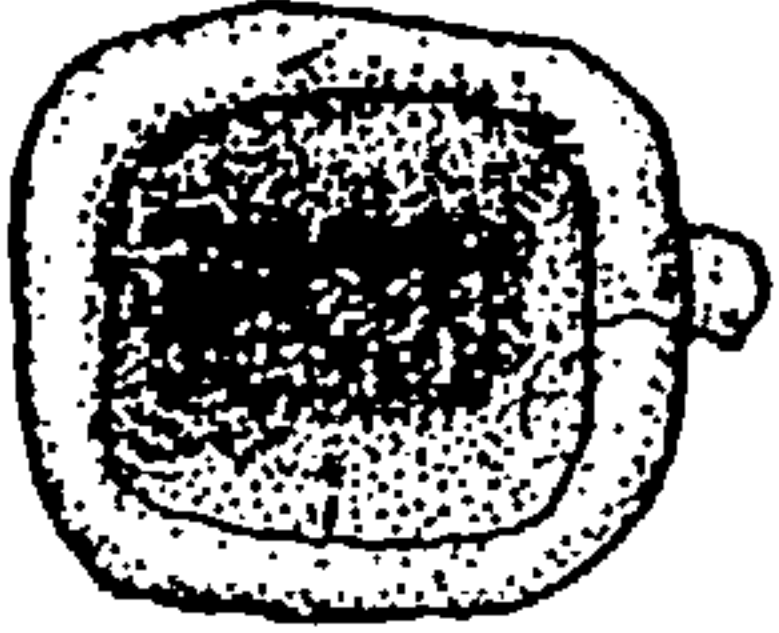
15/23



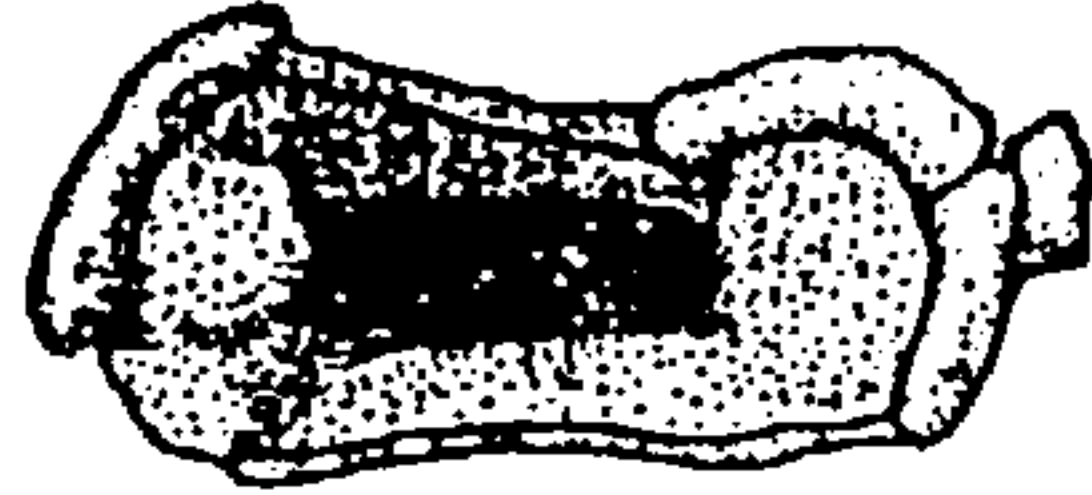
0 2cm

Fig. 16 The Bexley Heath Hoard (Ref. No. 15): Complete Socketed Axes (iv)

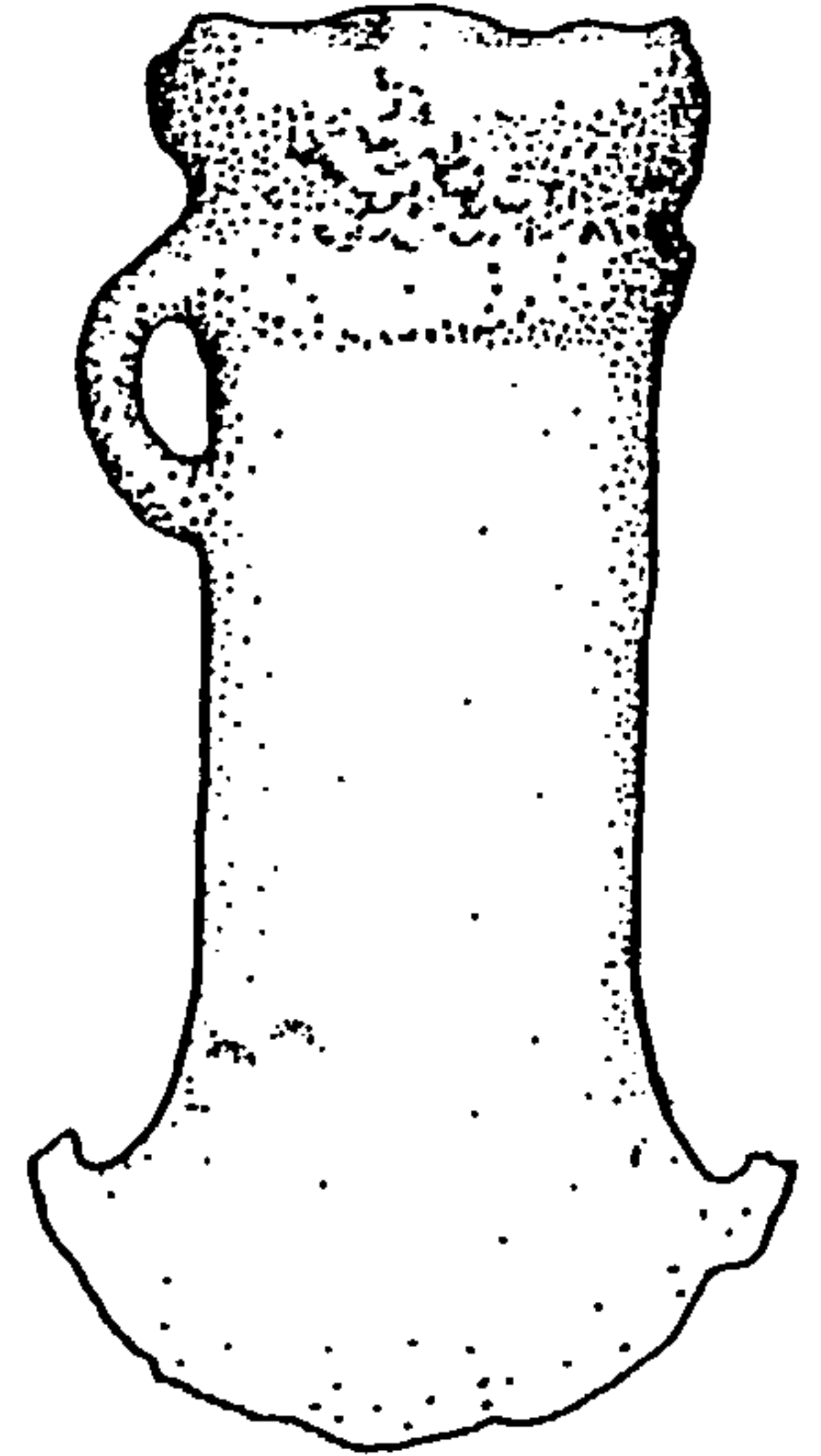
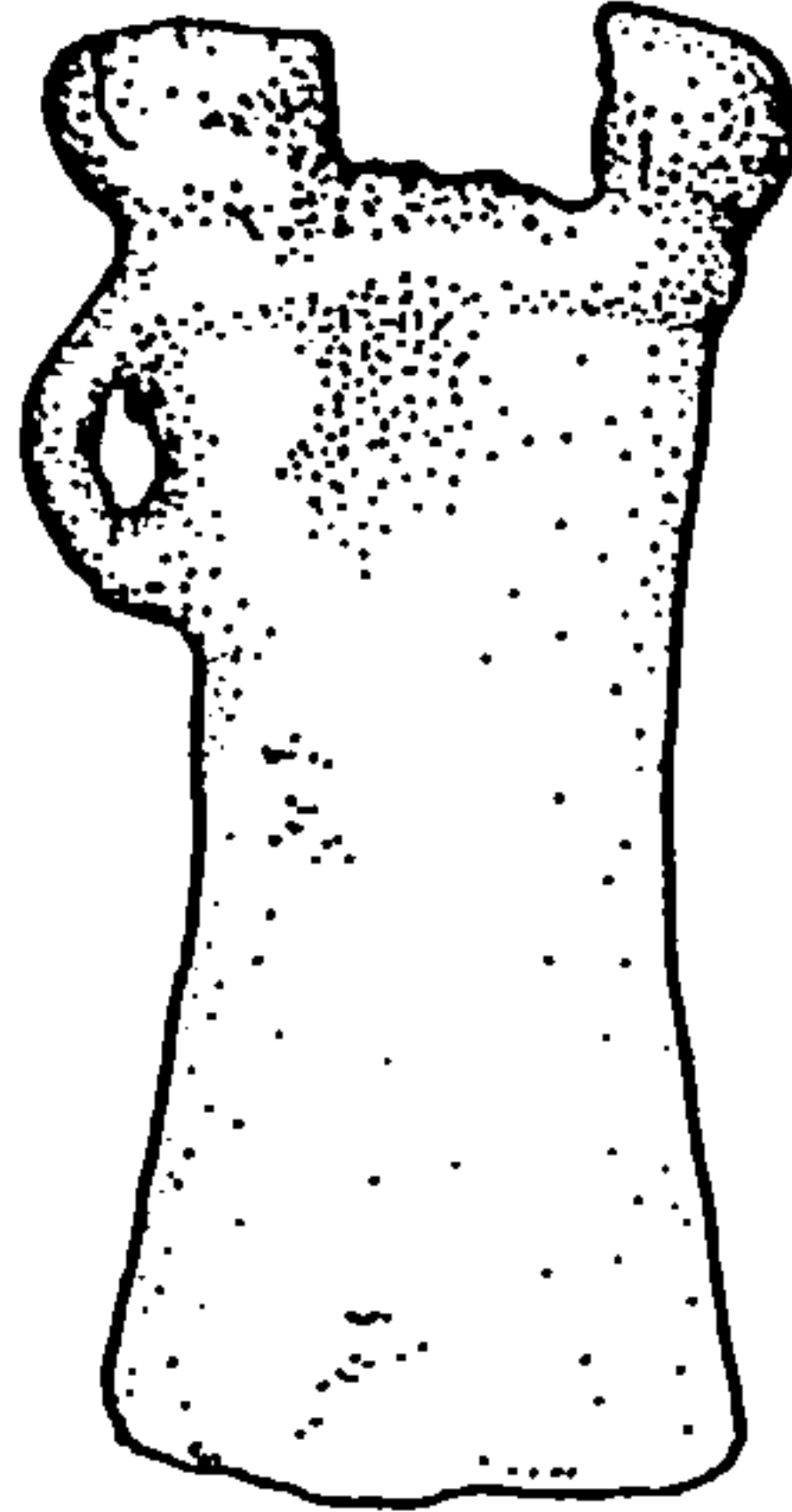
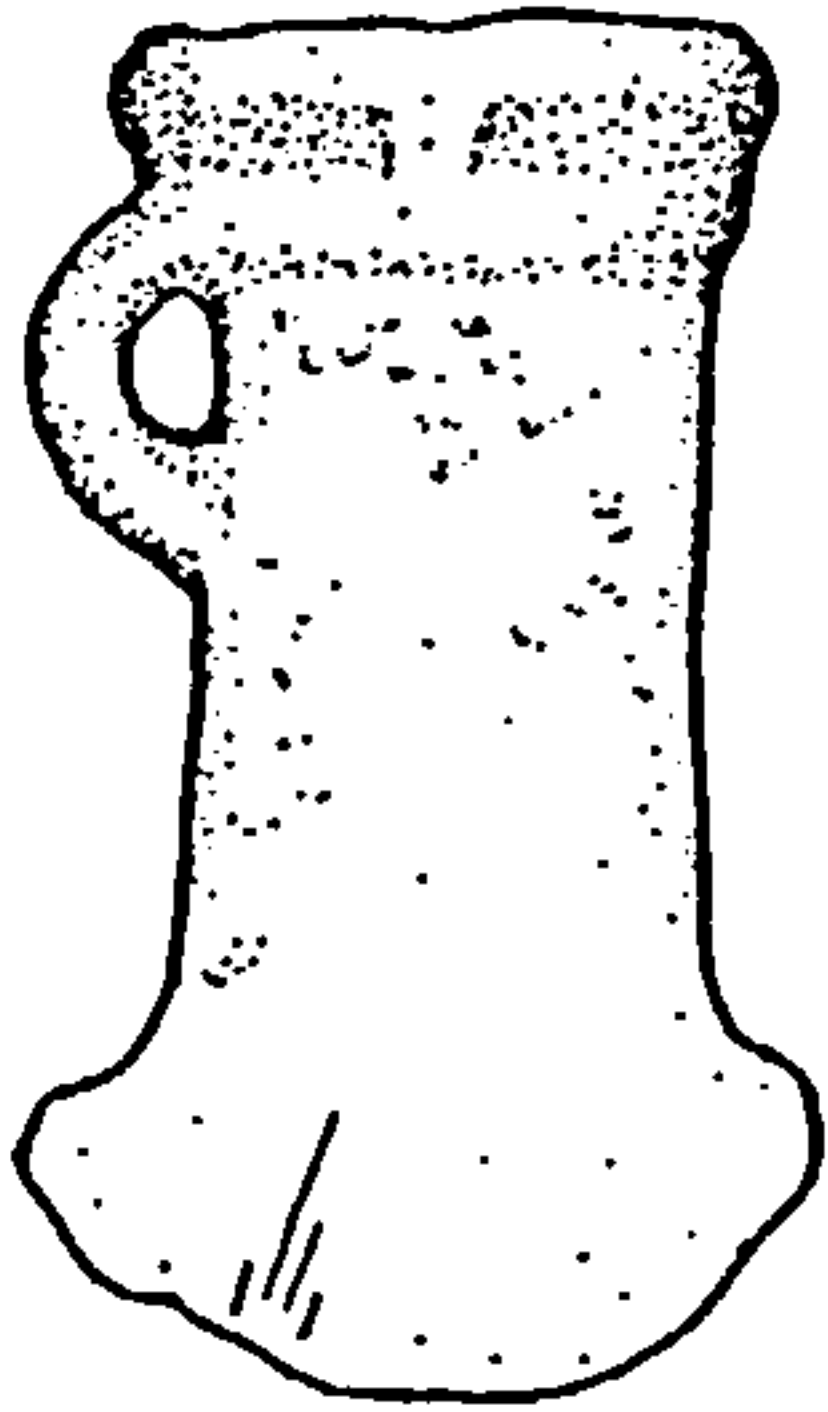
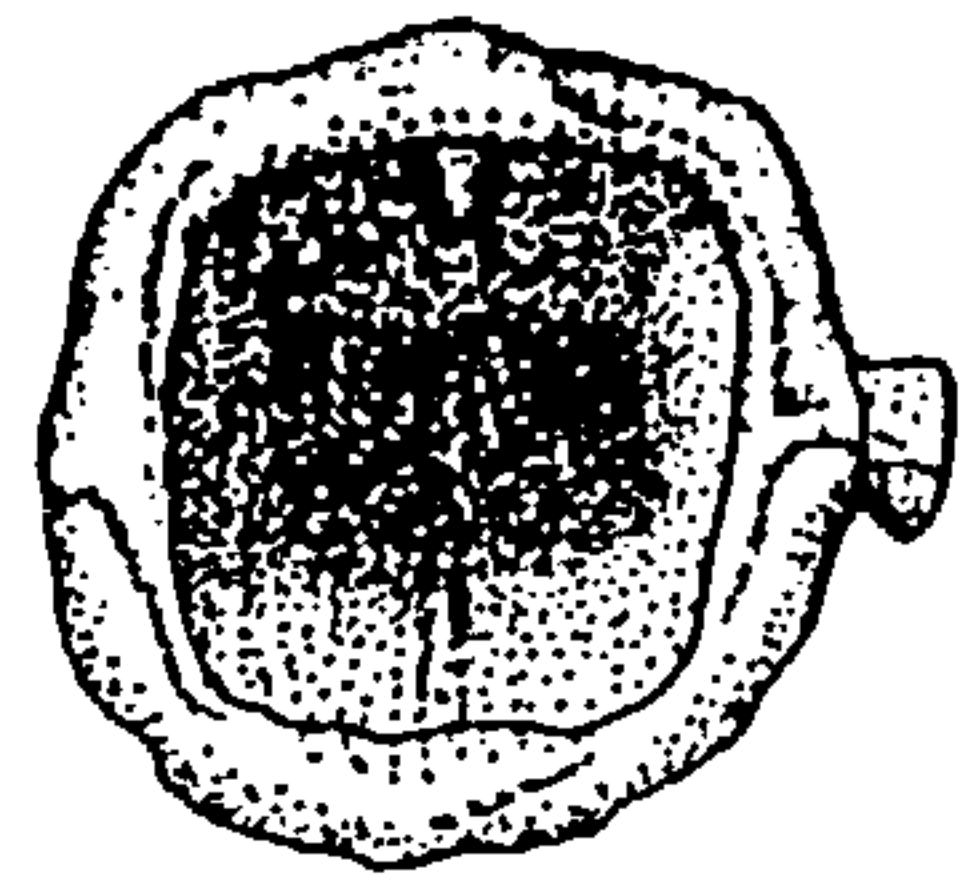
15/24



15/25

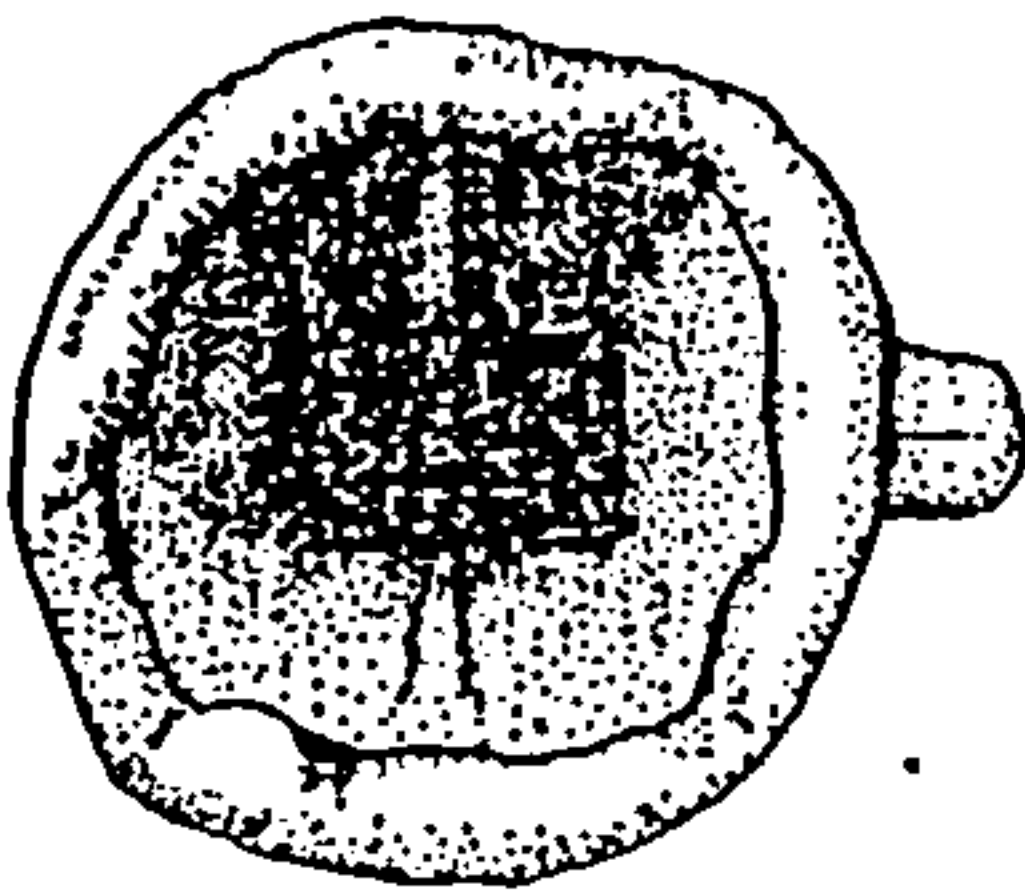


15/26

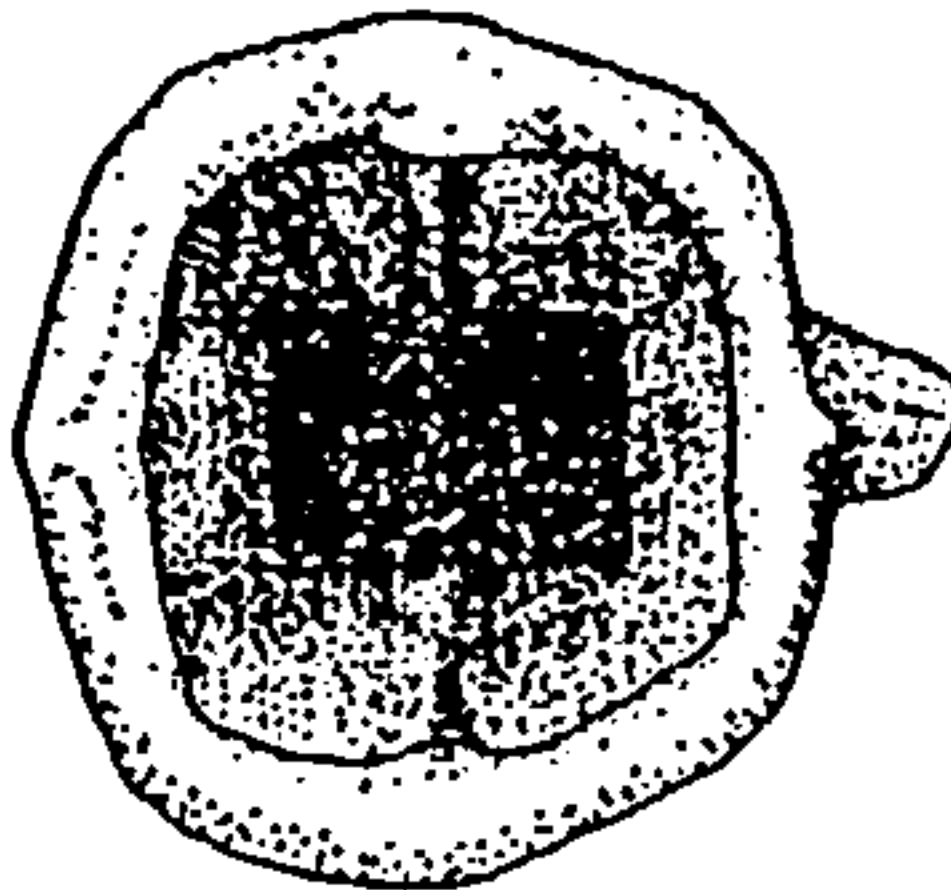


0 2cm

15/27



15/28



15/29

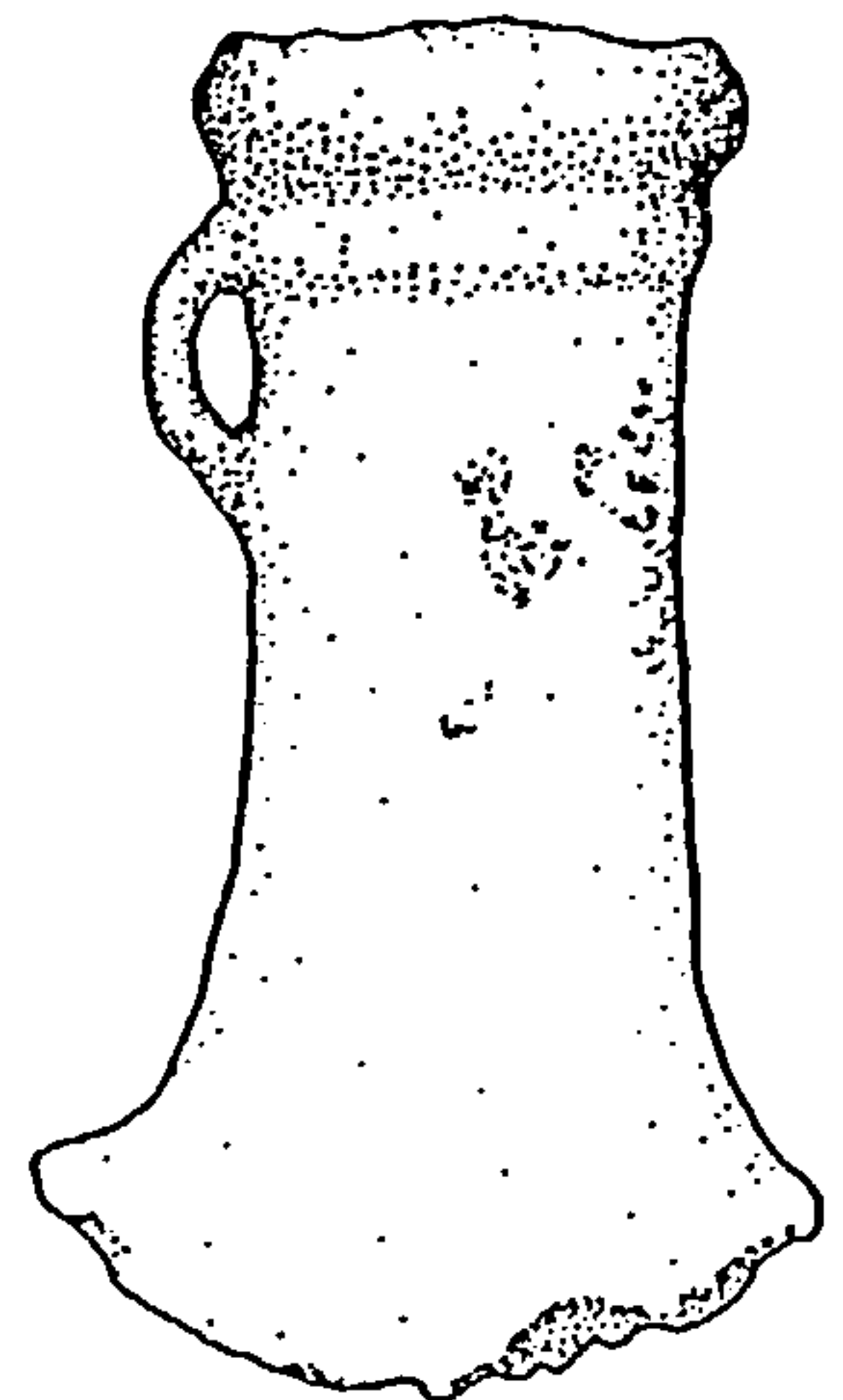
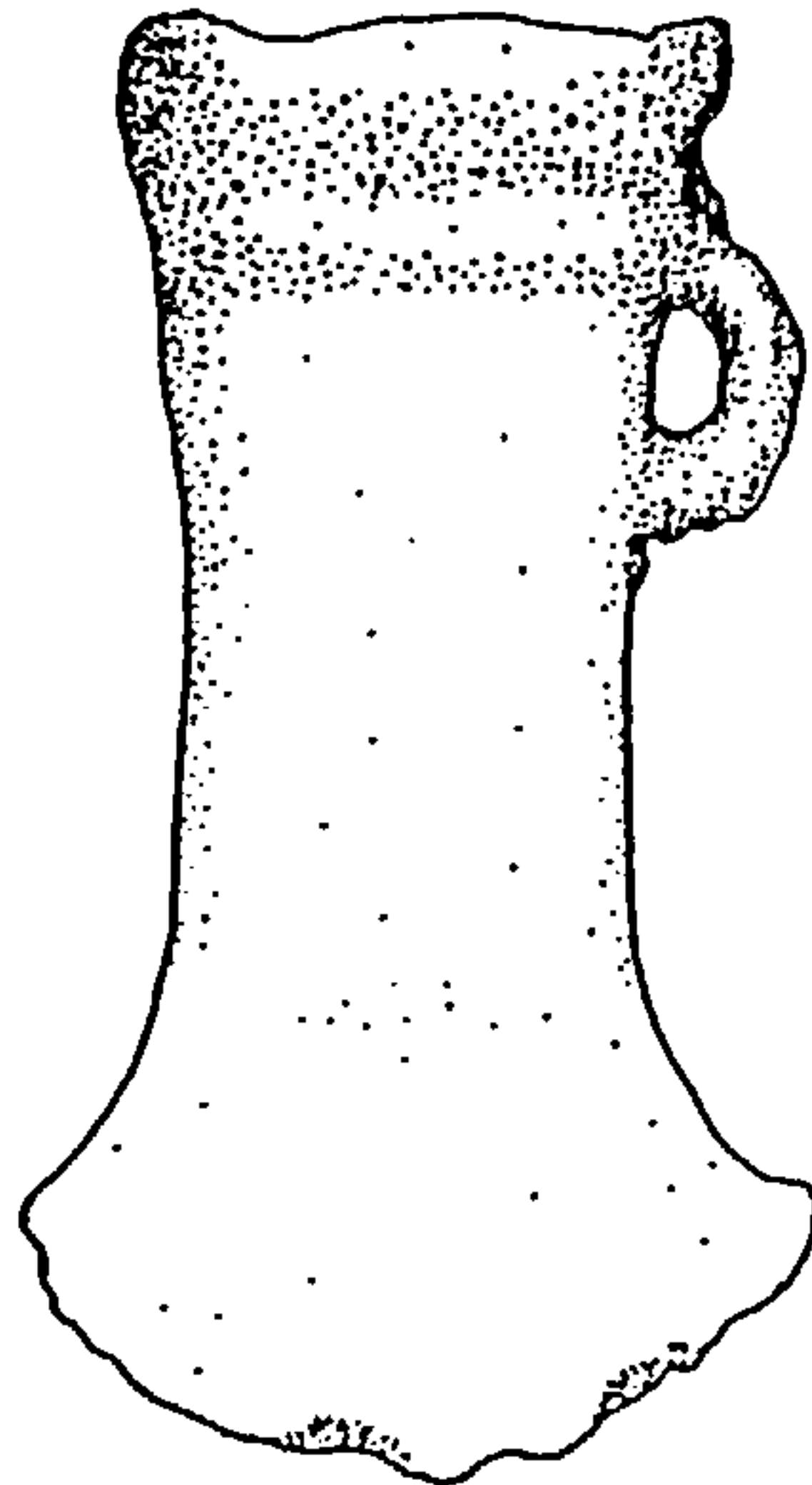
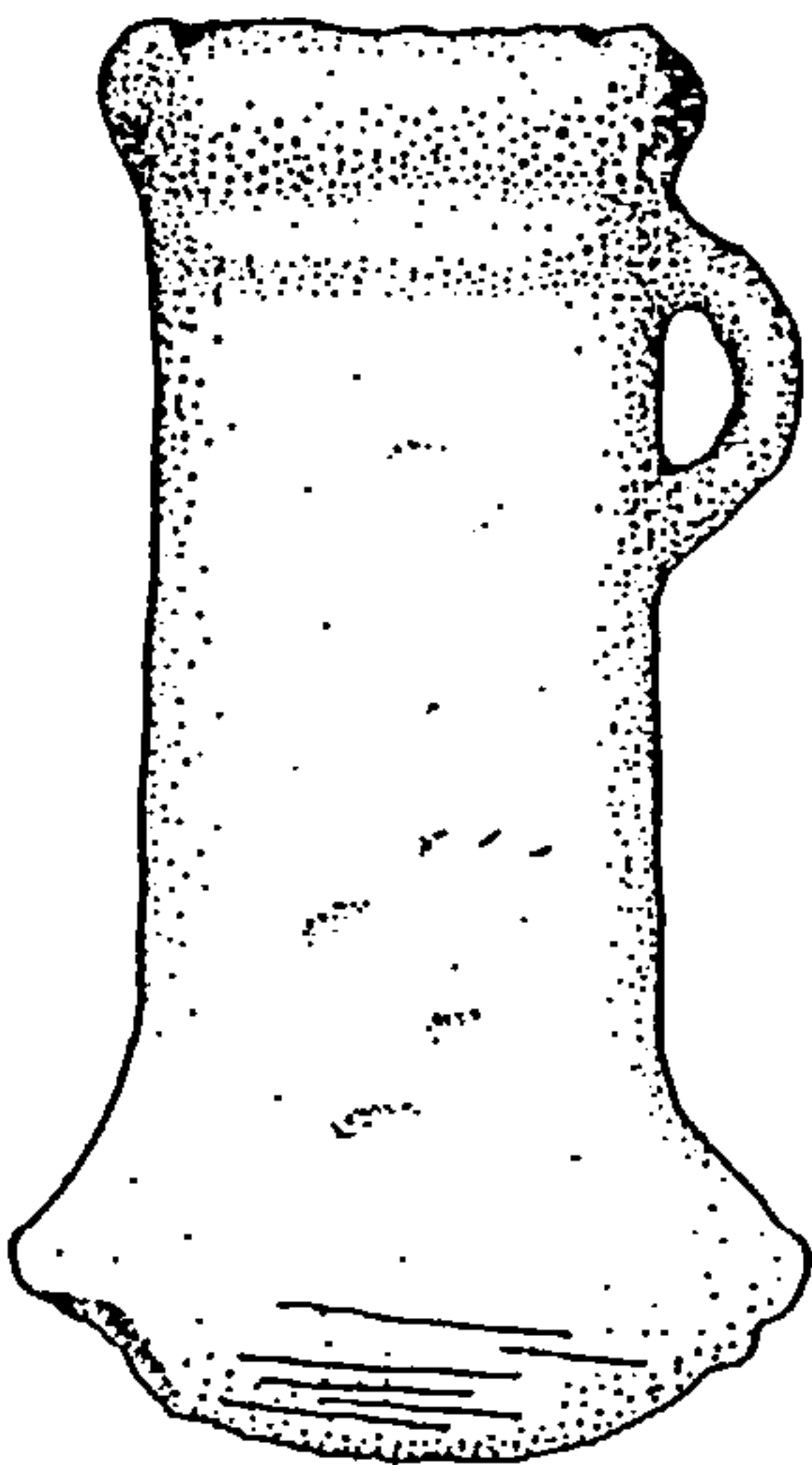
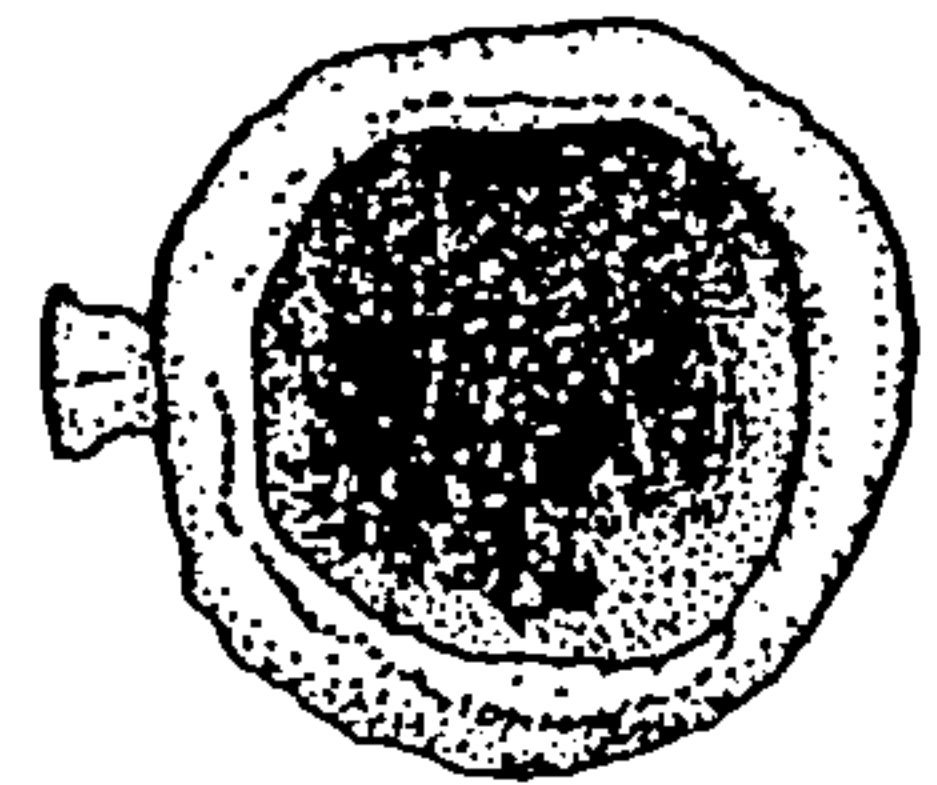
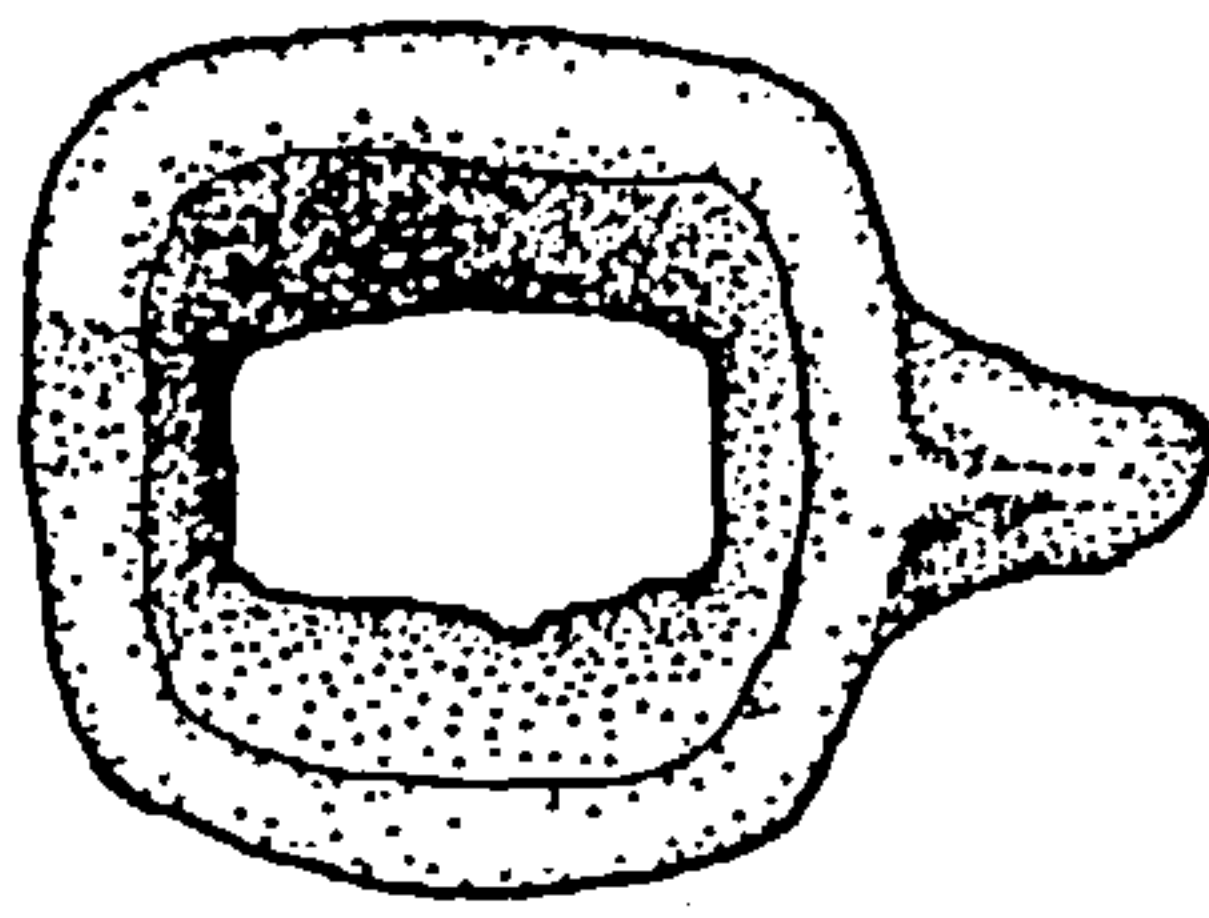


Fig. 17 The Bexley Heath Hoard (Ref. No. 15): Complete Socketed Axes (v)

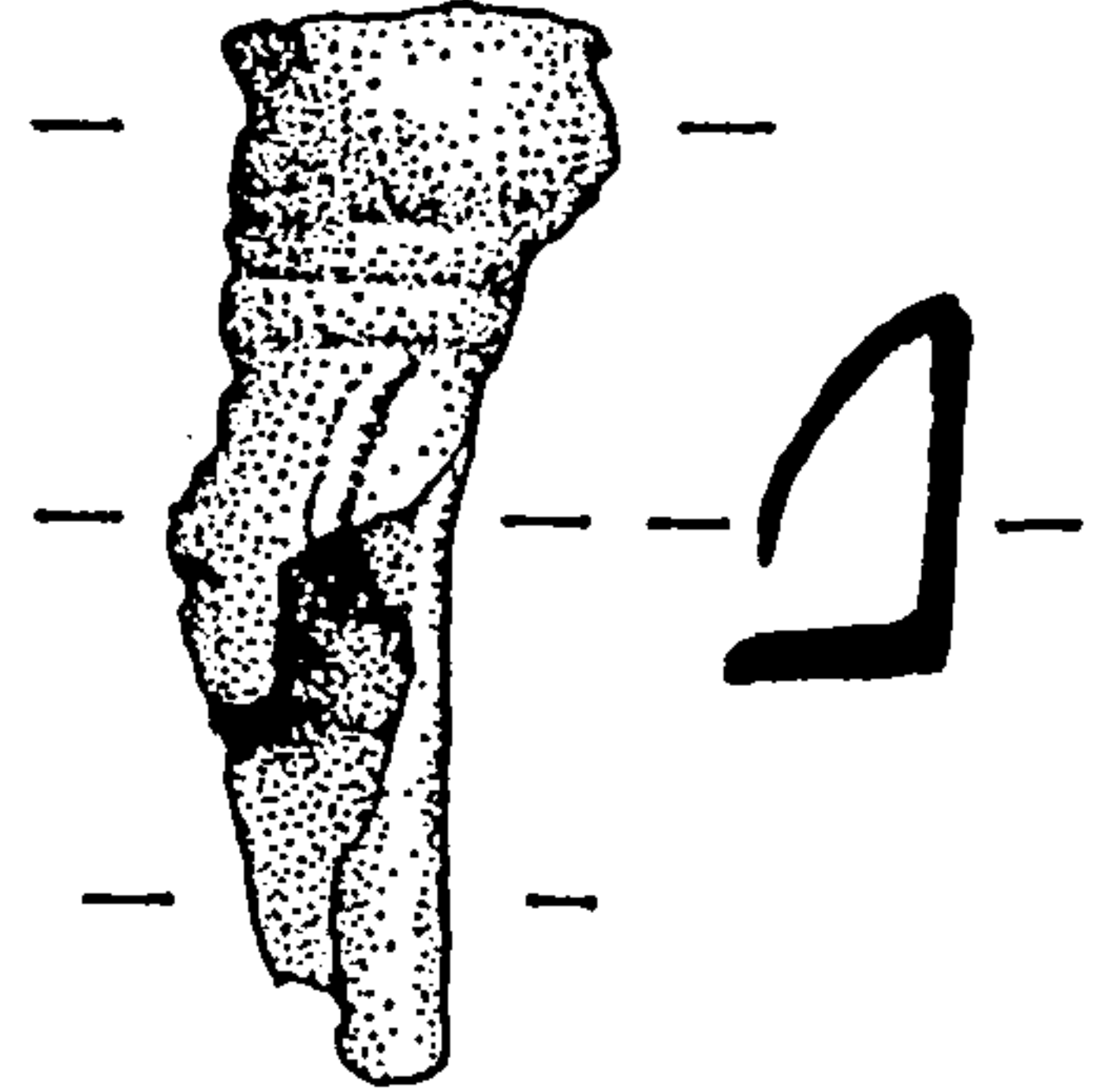
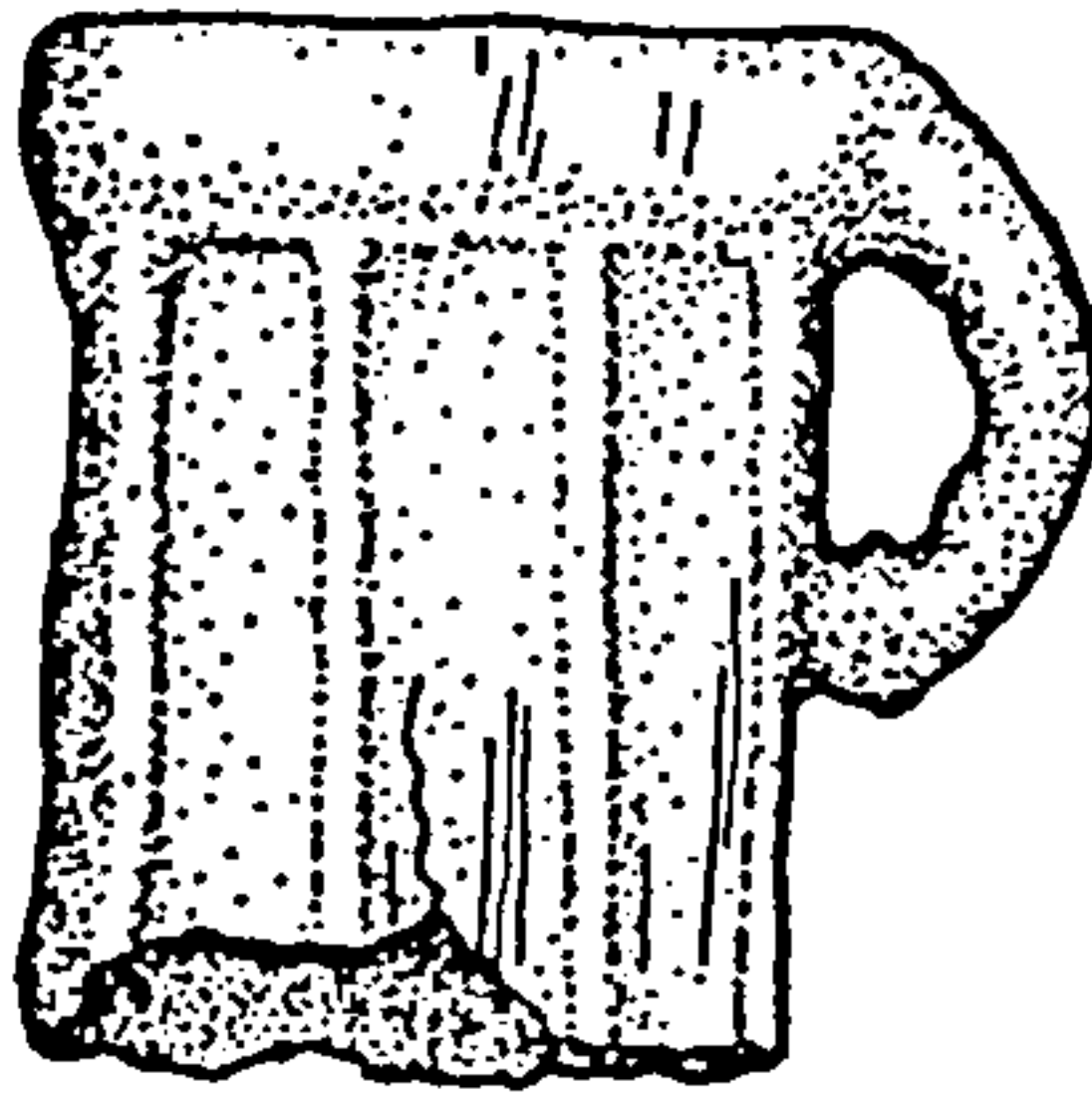
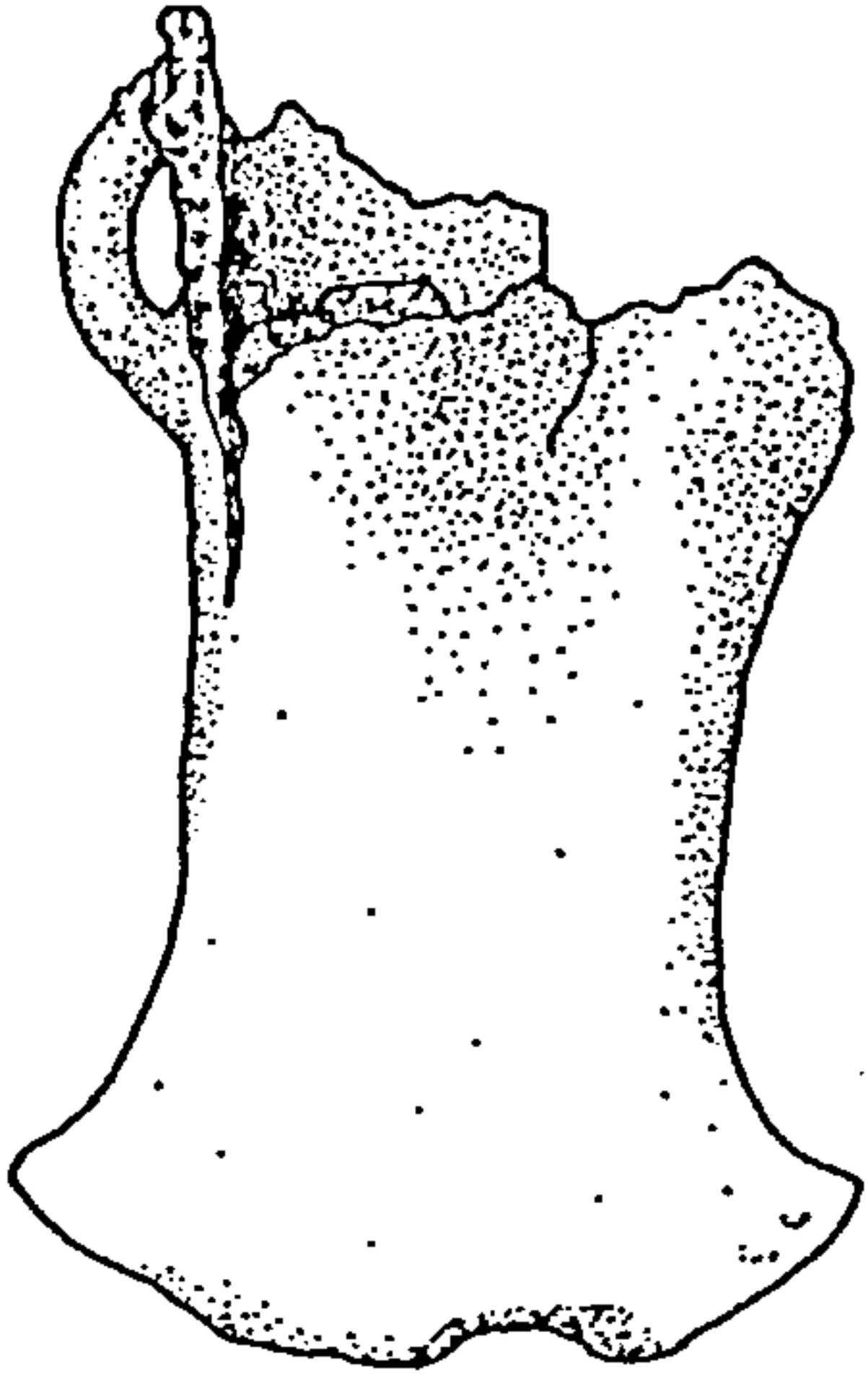
15/30



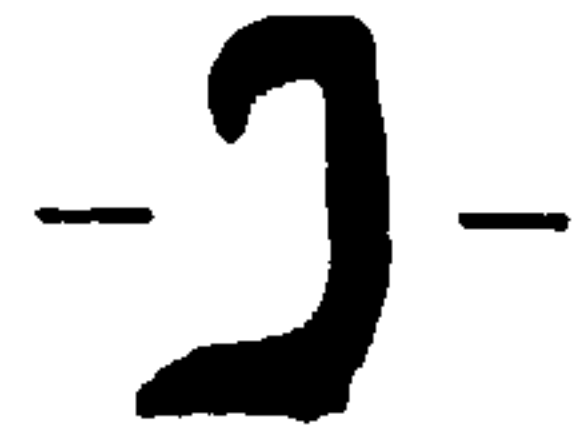
15/31



15/32



0 2cm



15/33



15/34



15/35

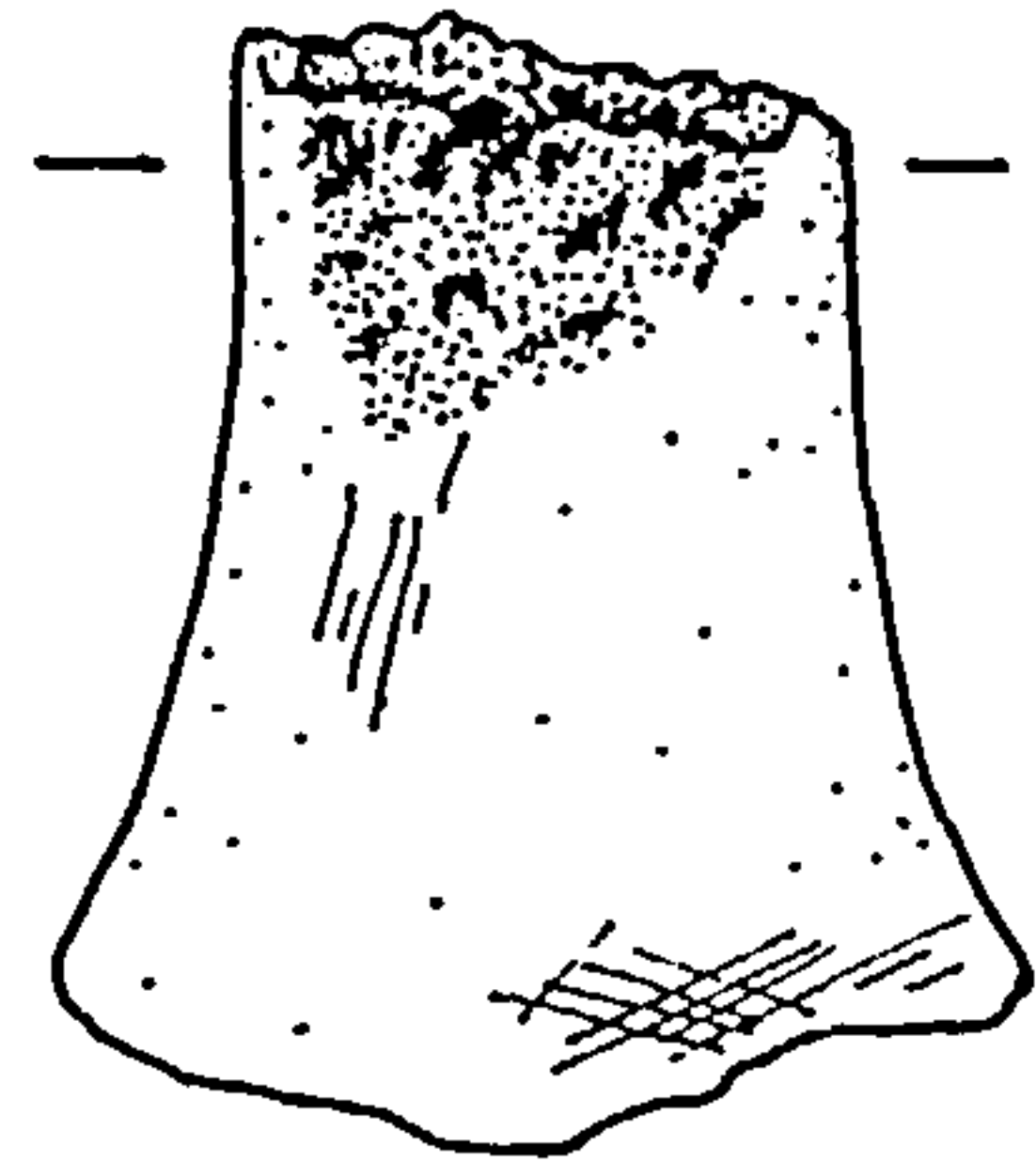
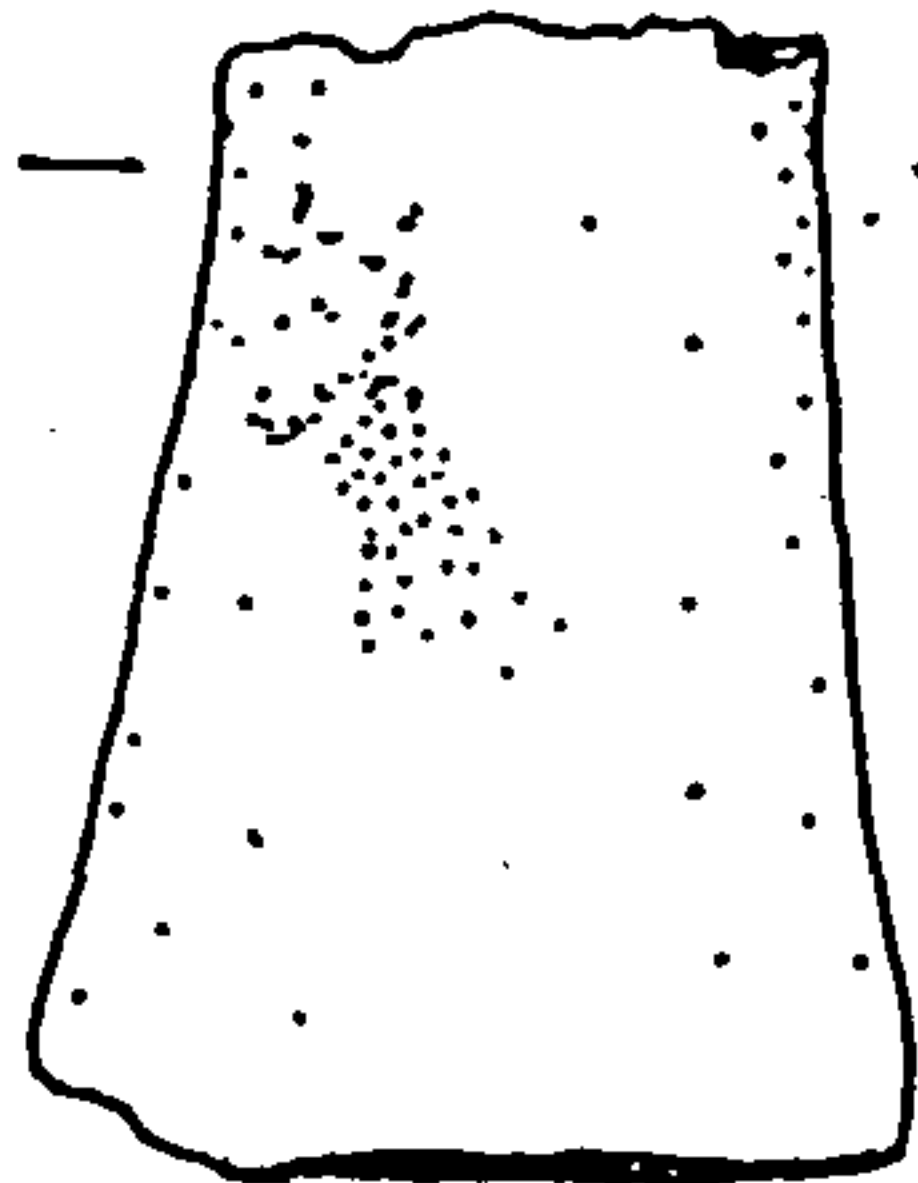
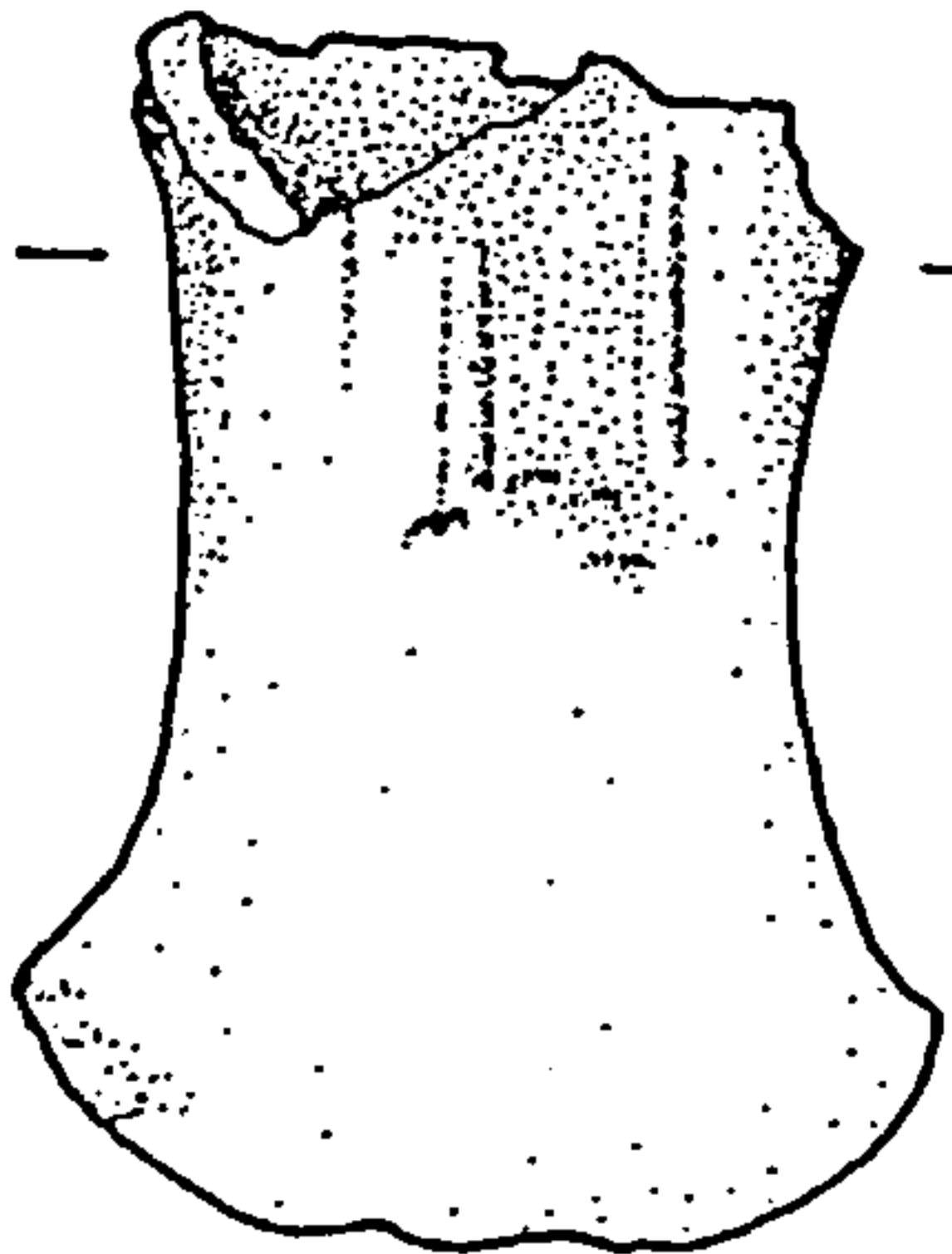


Fig. 18 The Bexley Heath Hoard (Ref. No. 15): Socketed Axe Fragments (i)

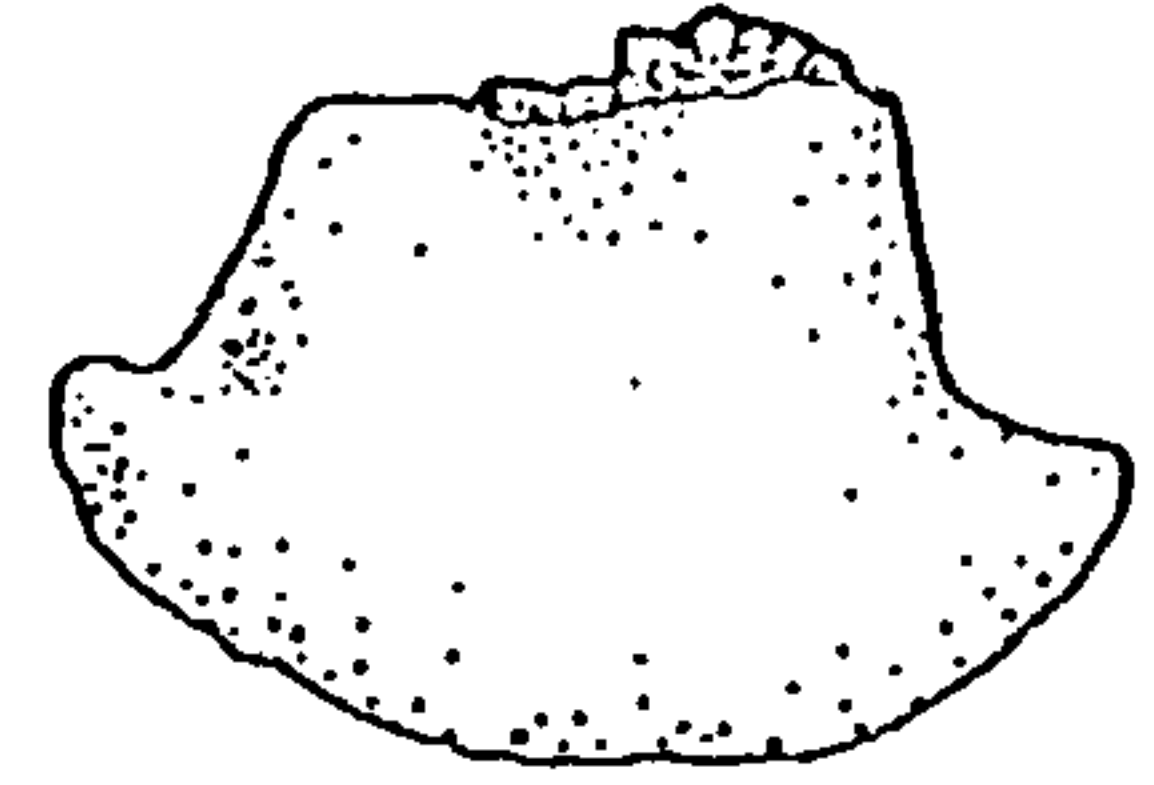
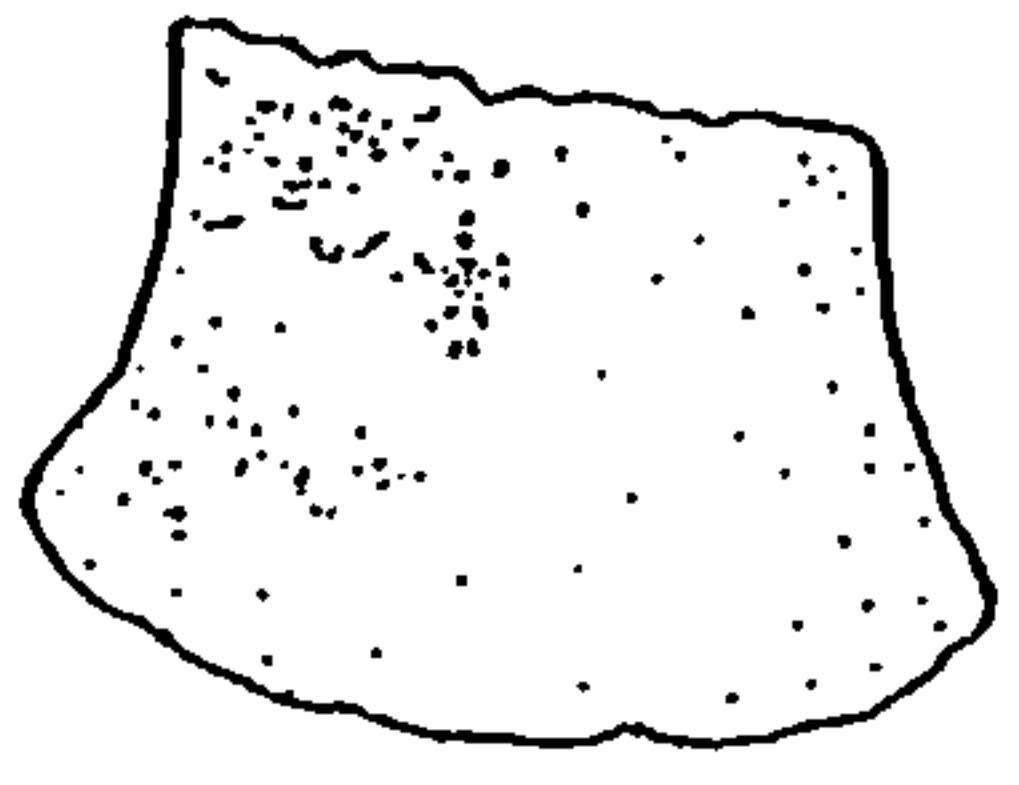
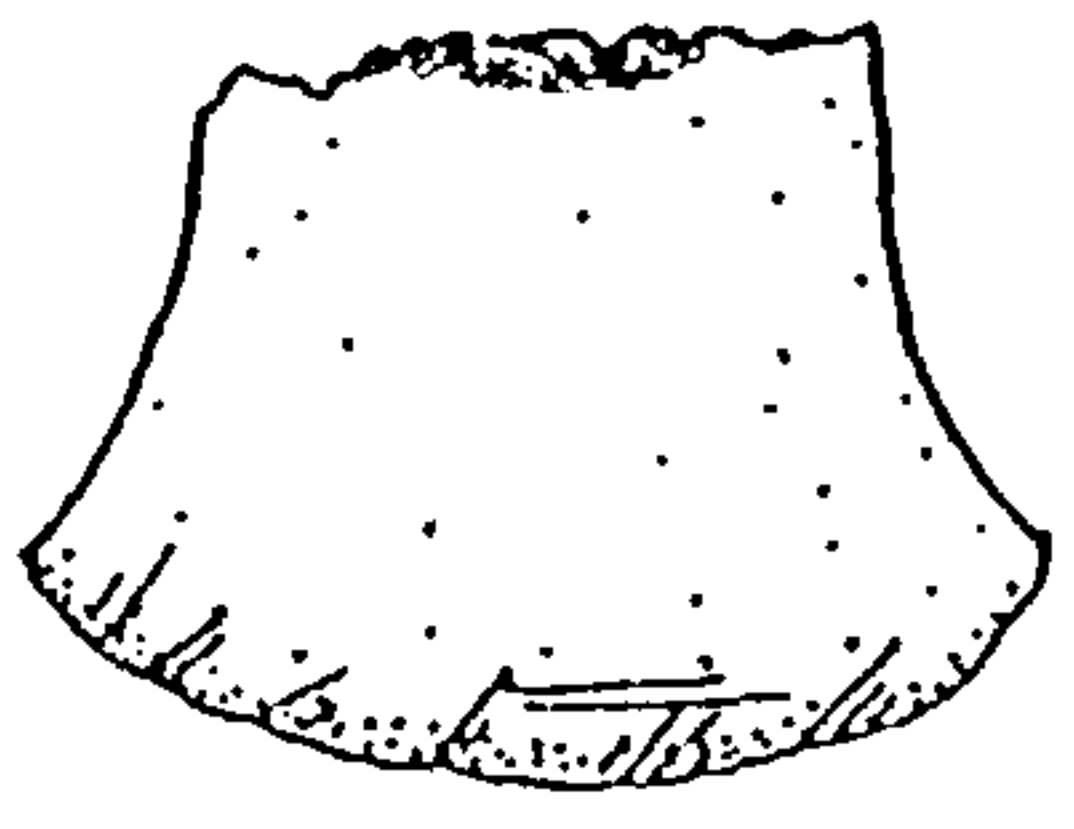
0 2cm



15/36

15/37

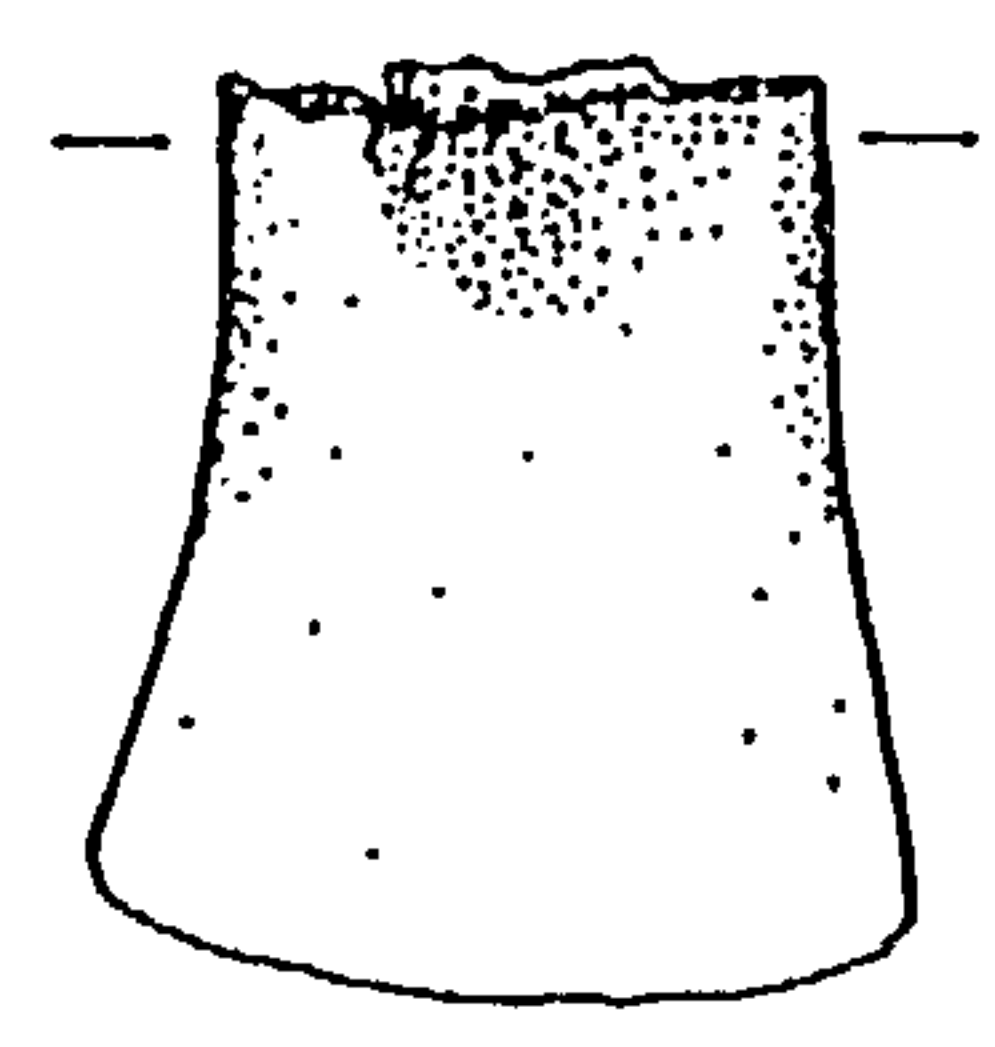
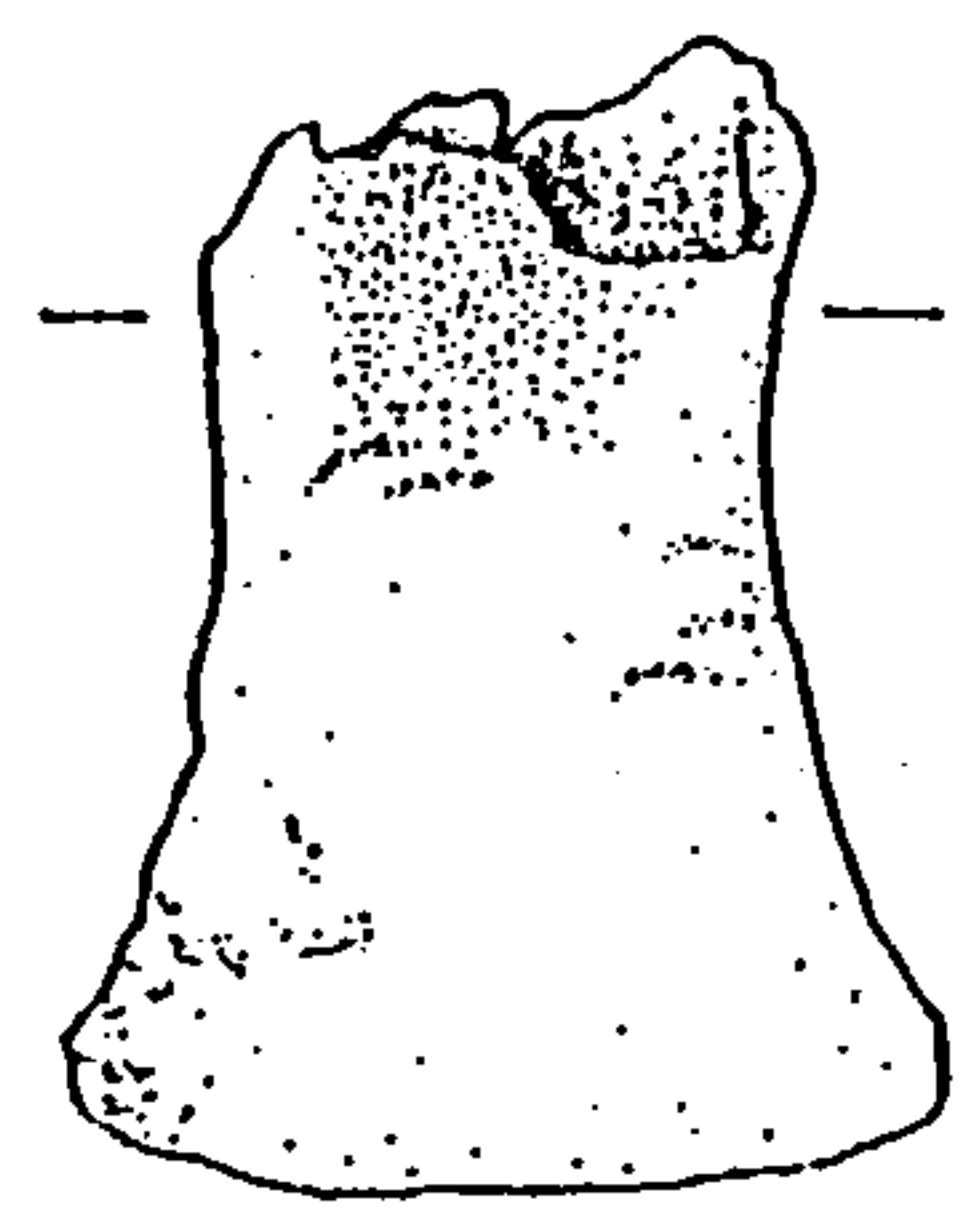
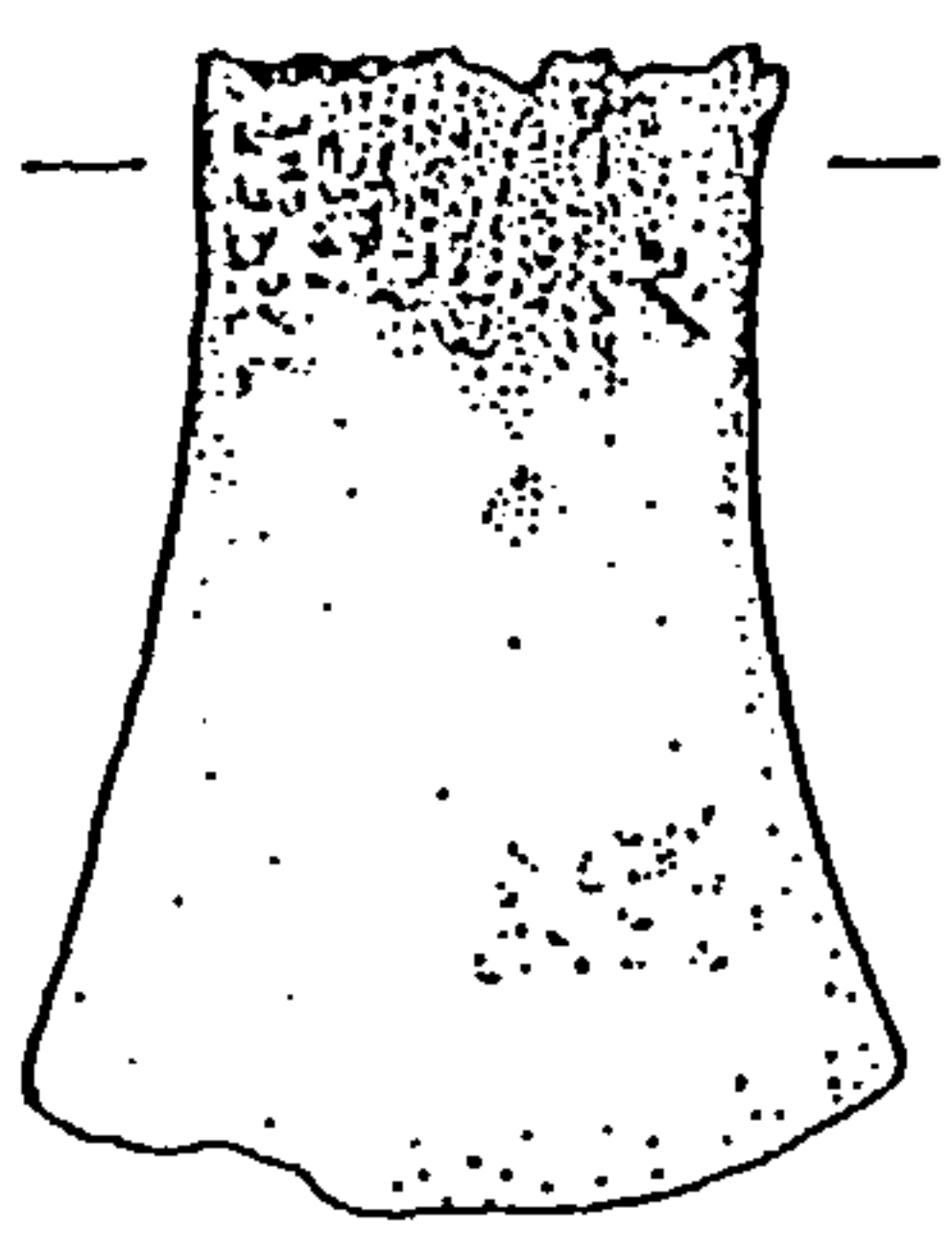
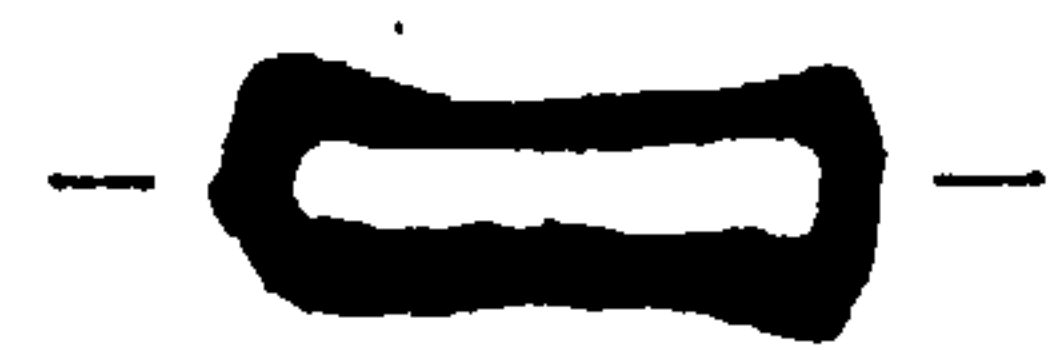
15/38



15/39

15/40

15/41



15/42

15/43

15/44

15/45

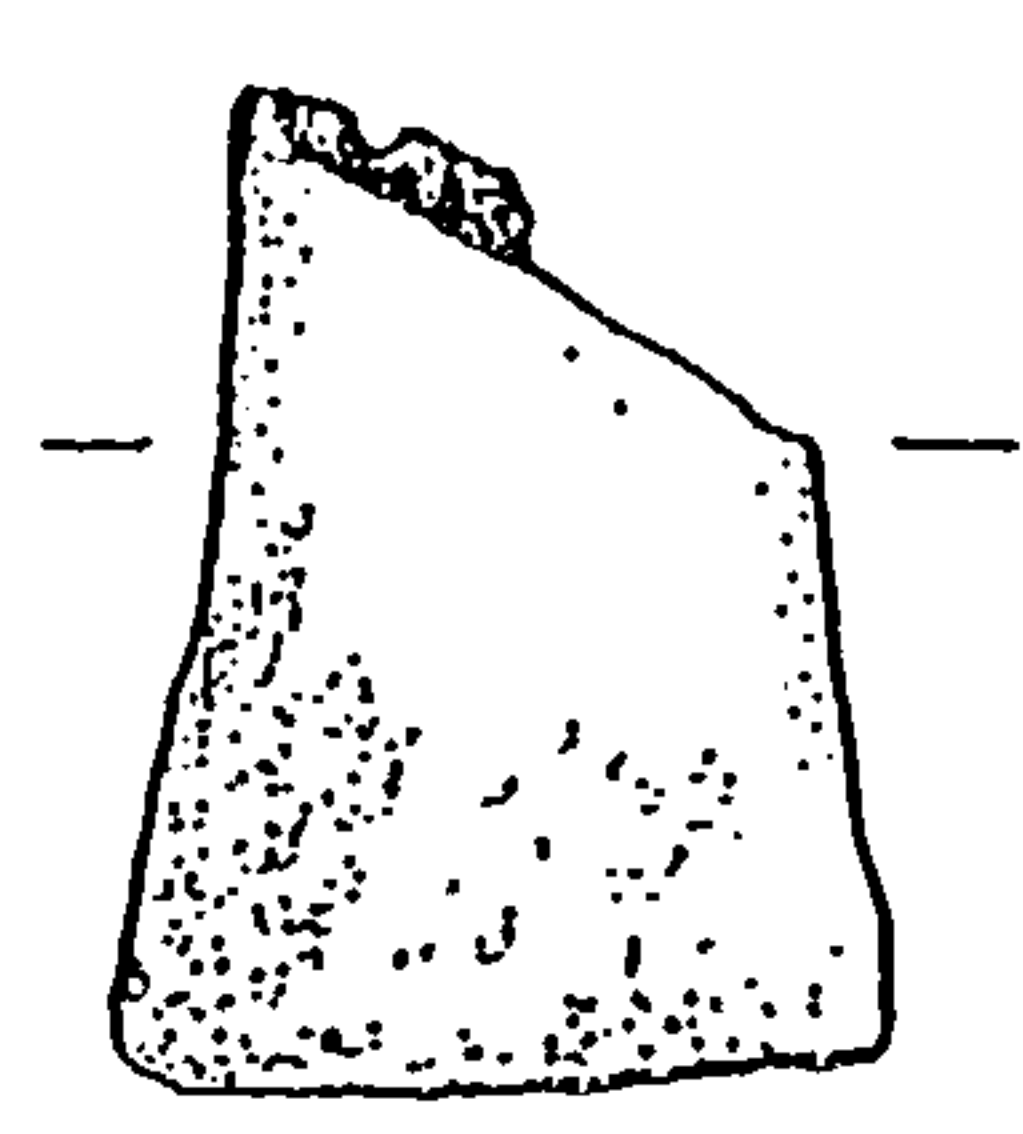
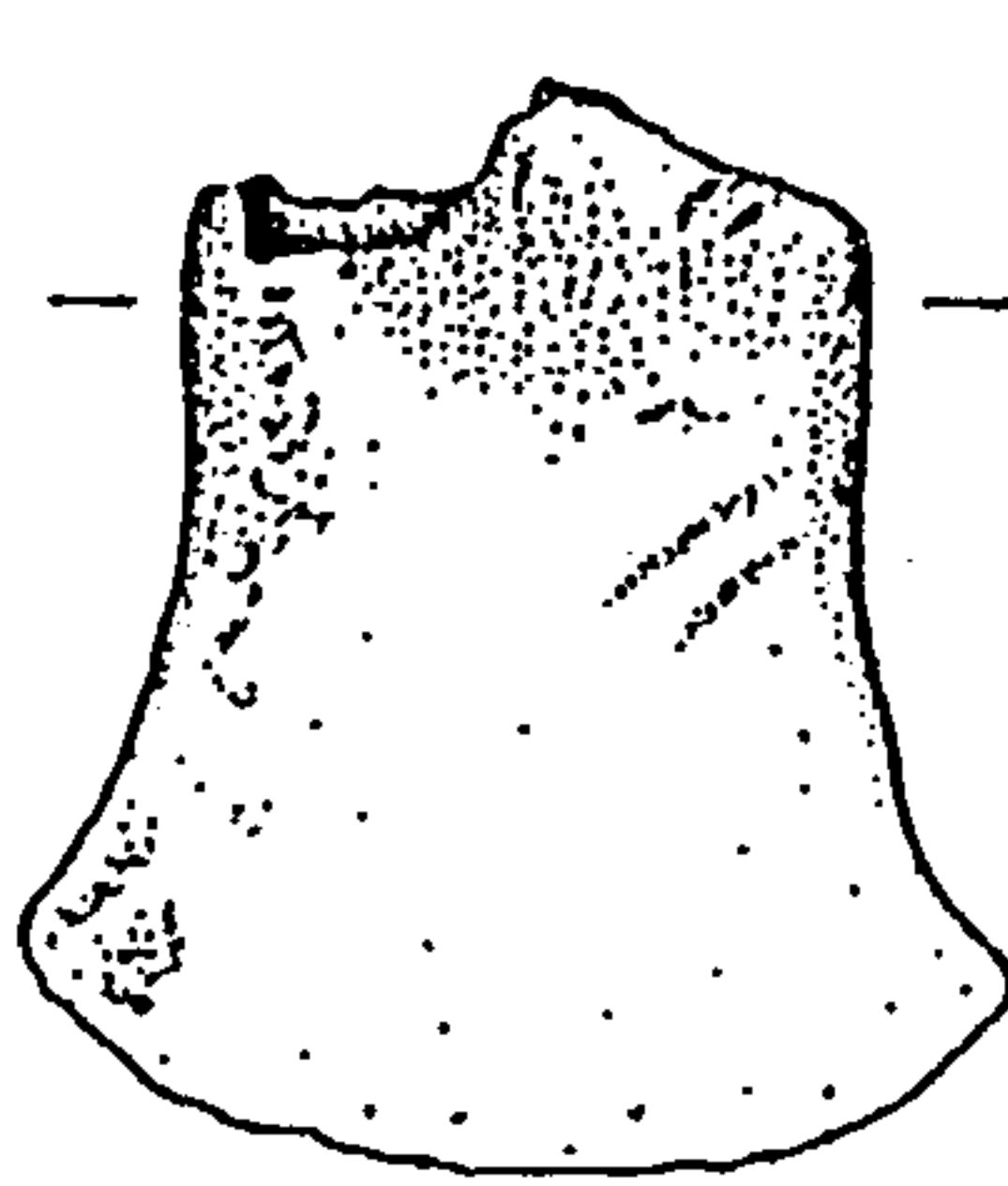
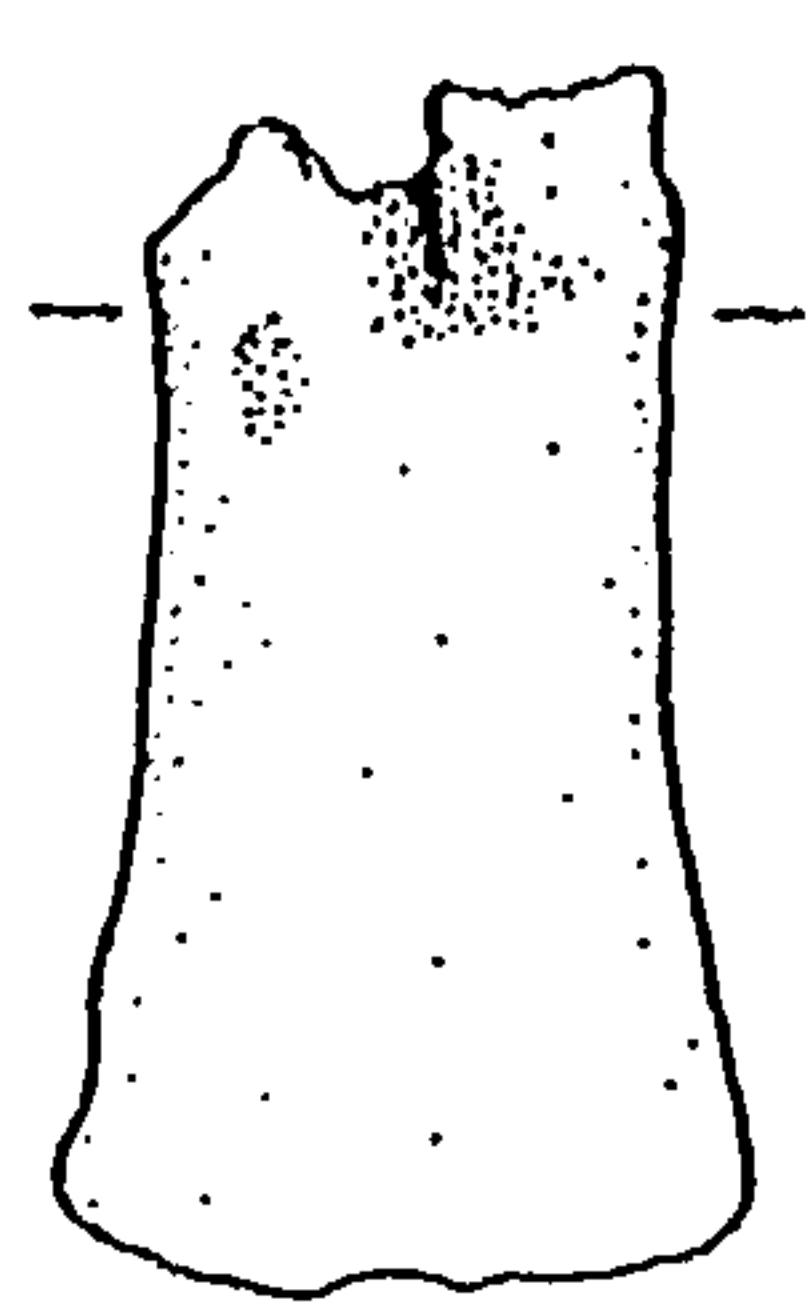
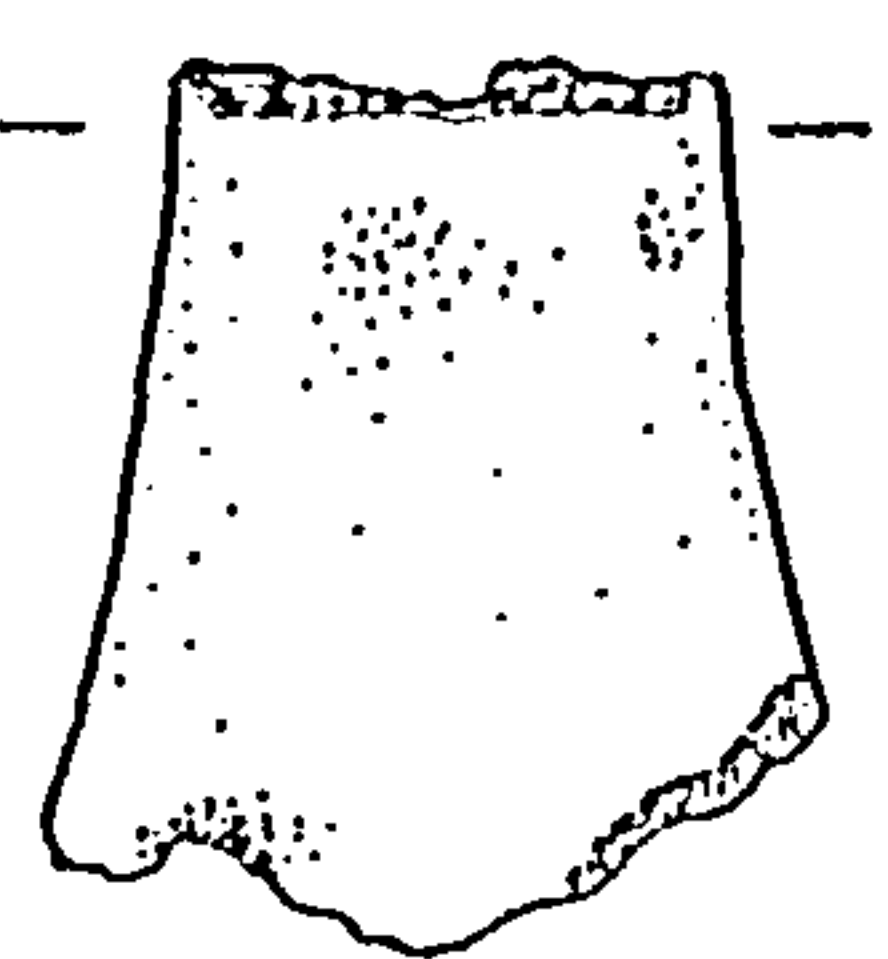
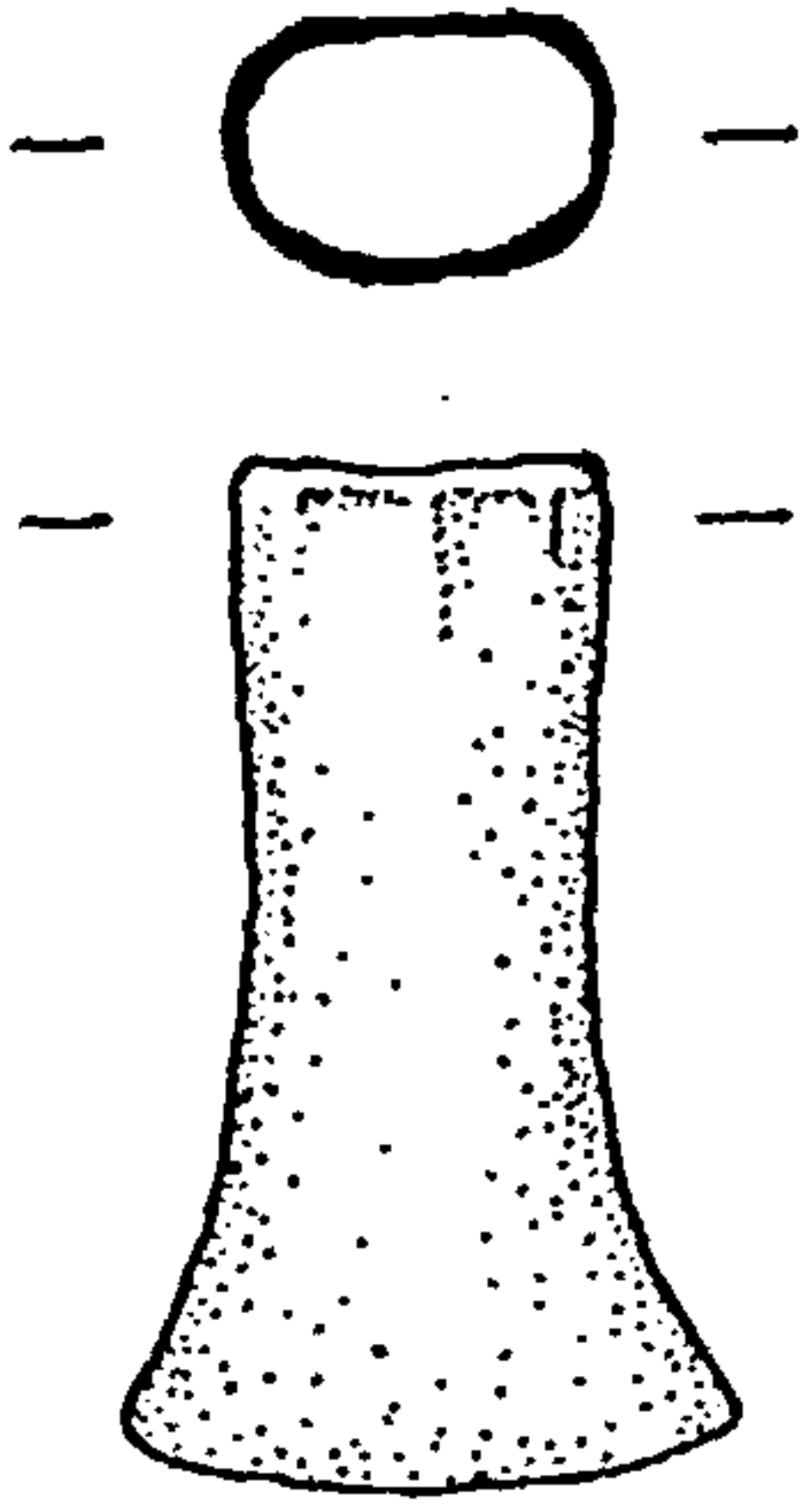
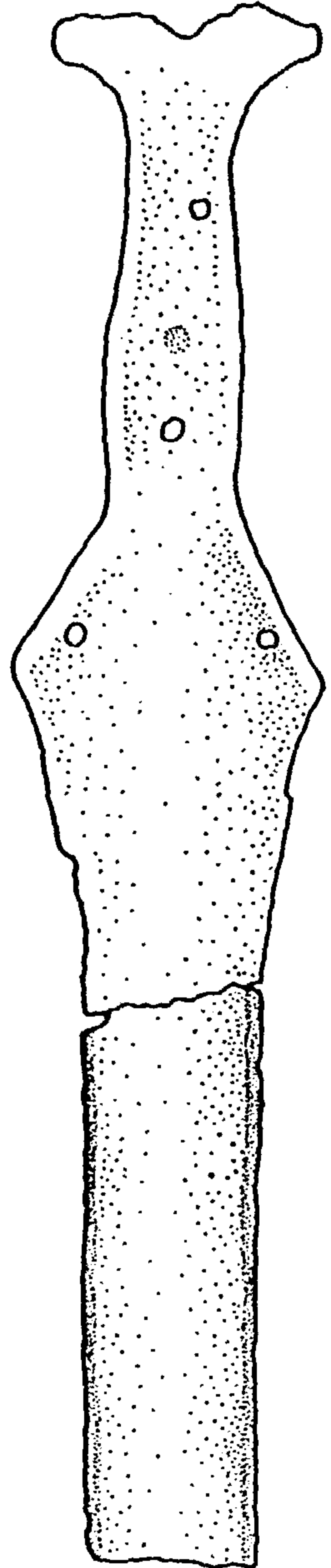


Fig. 19 The Bexley Heath Hoard (Ref. No. 15): Socketed Axe Fragments (ii)

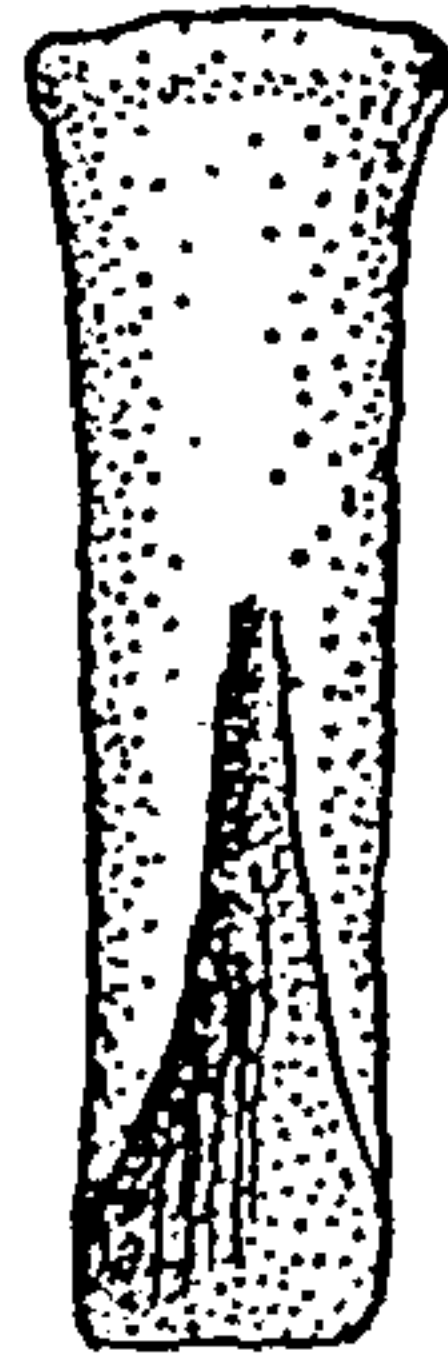
15/46



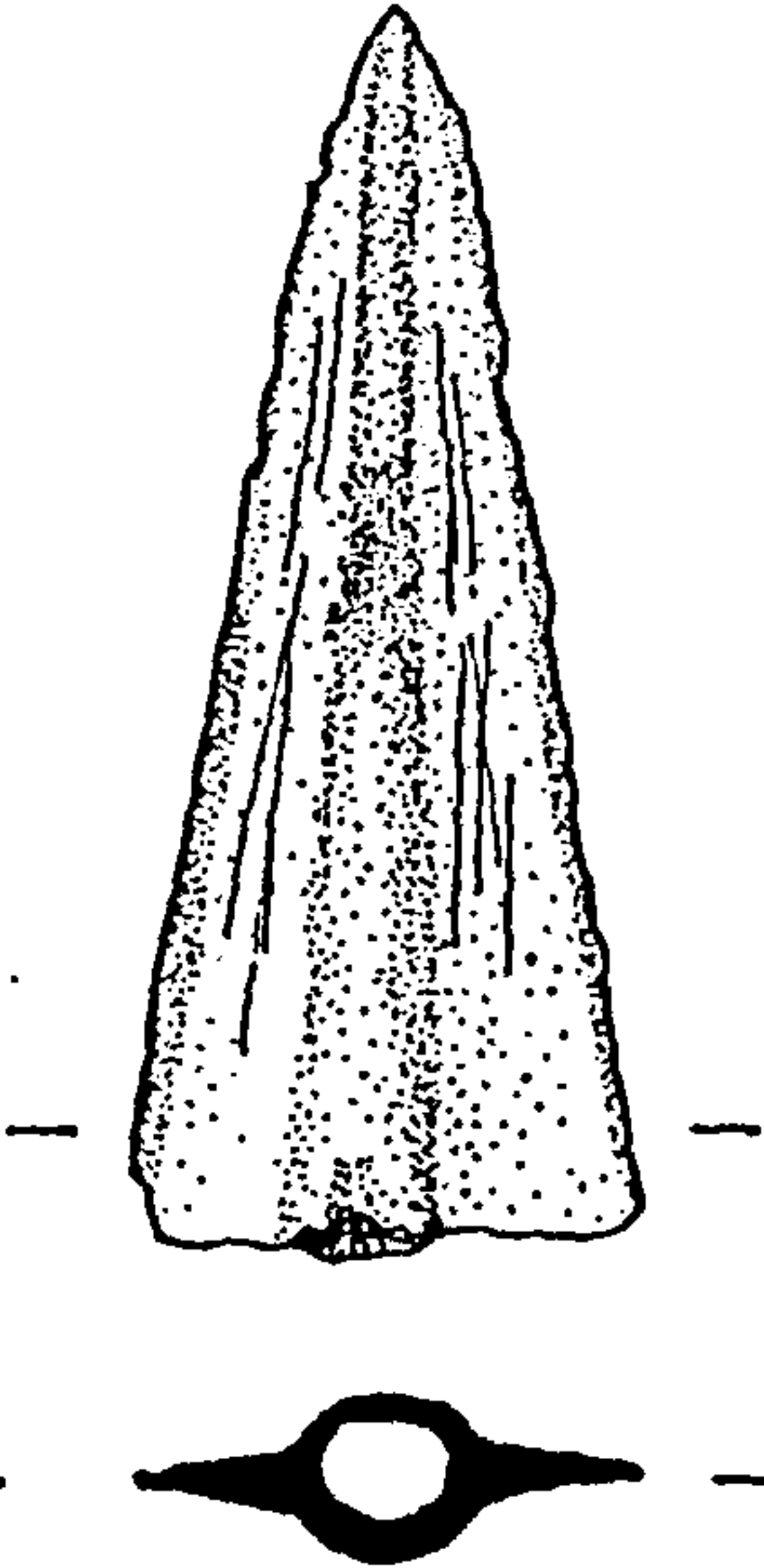
15/48



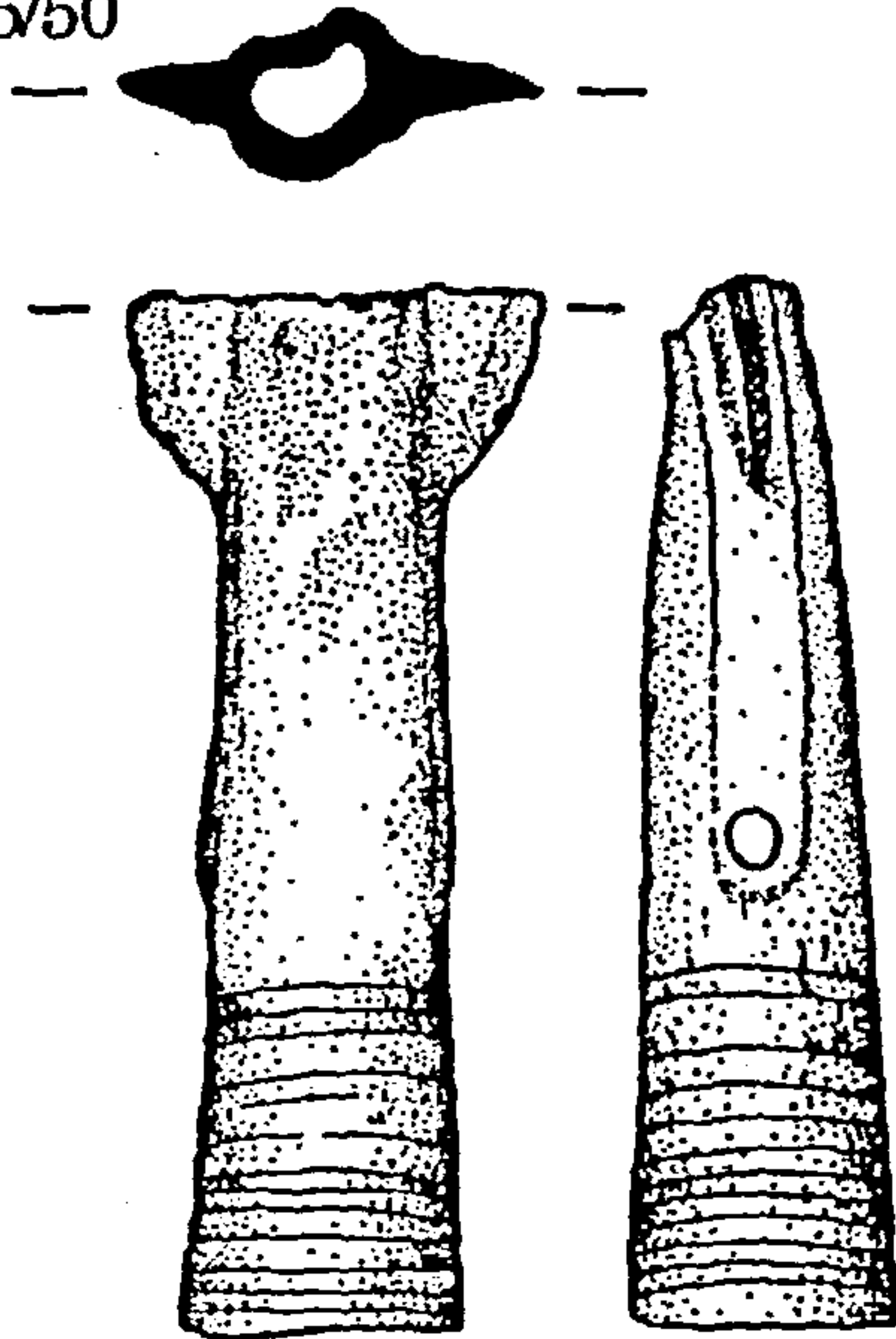
15/47



15/49



15/50



0 2cm

15/51

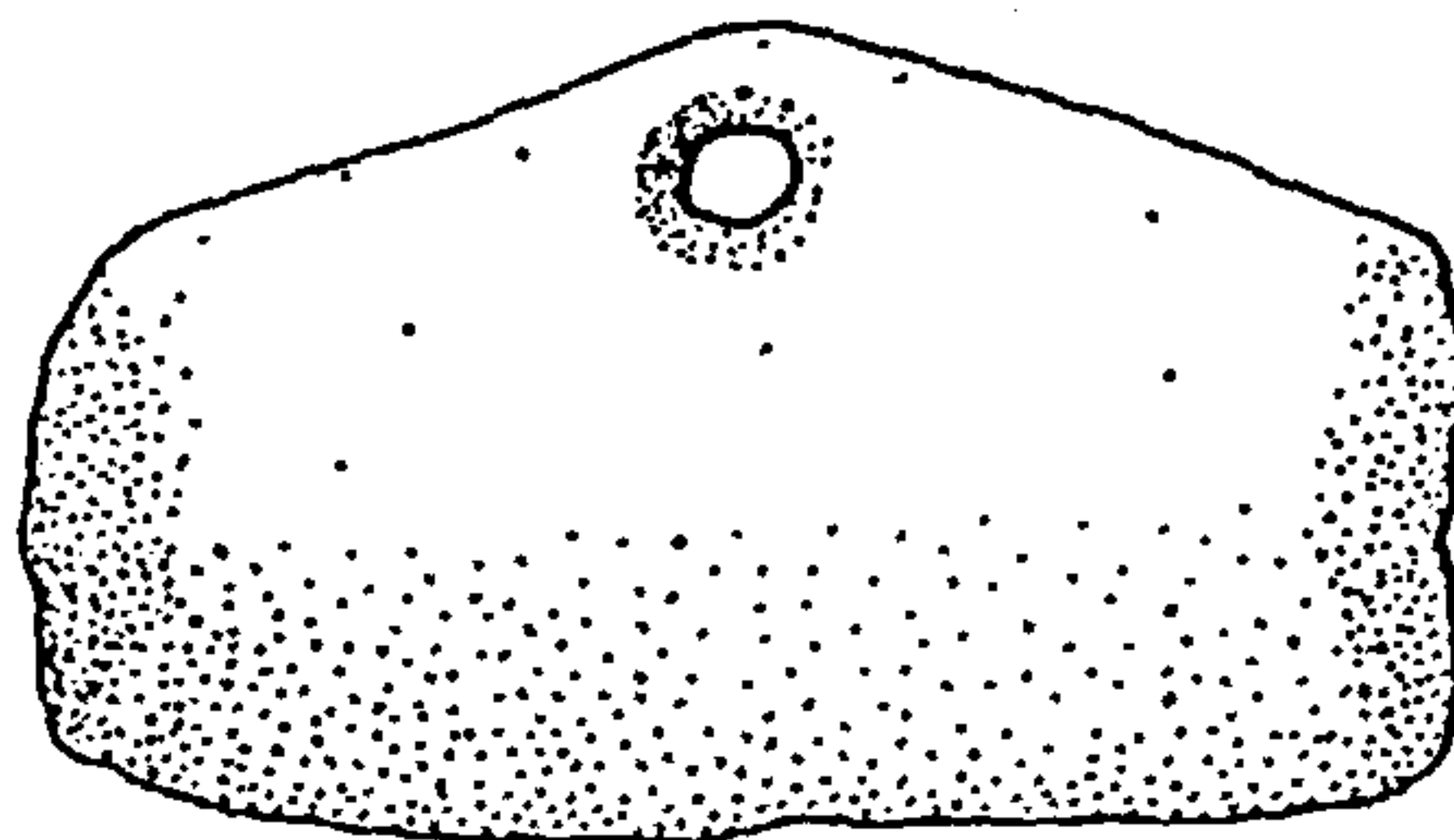
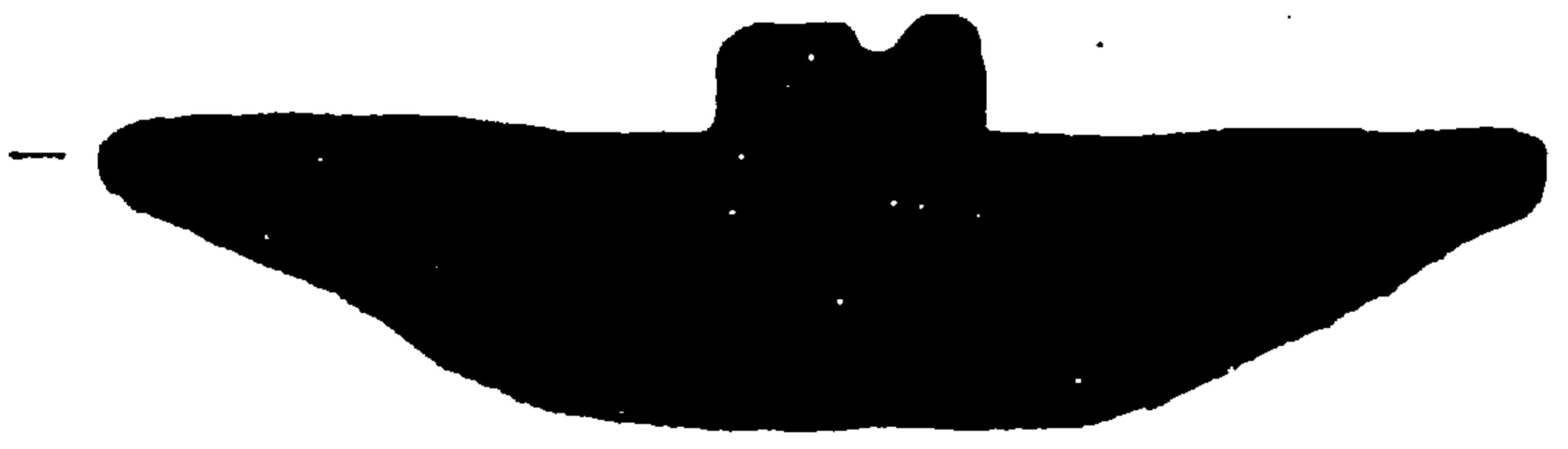
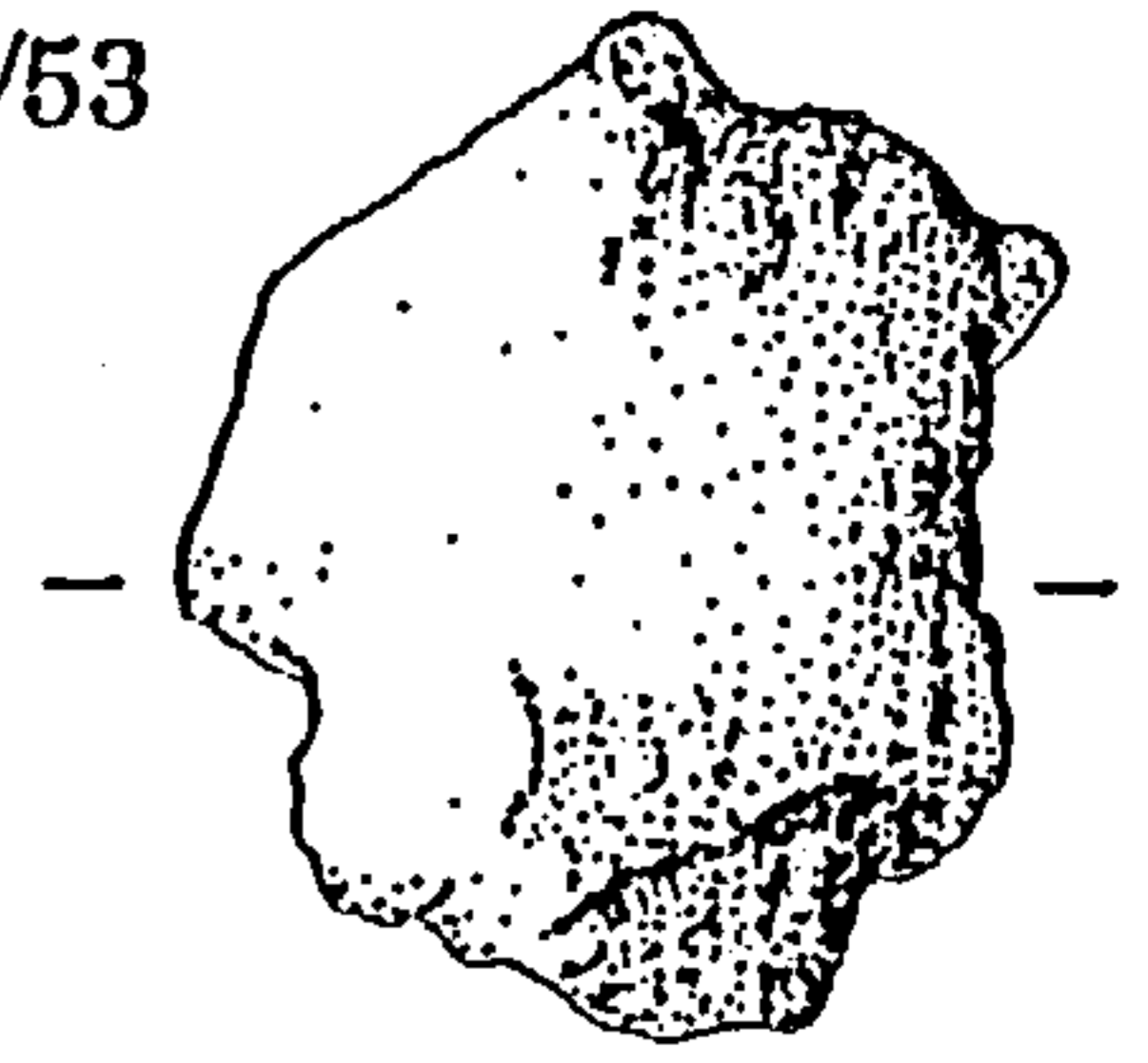
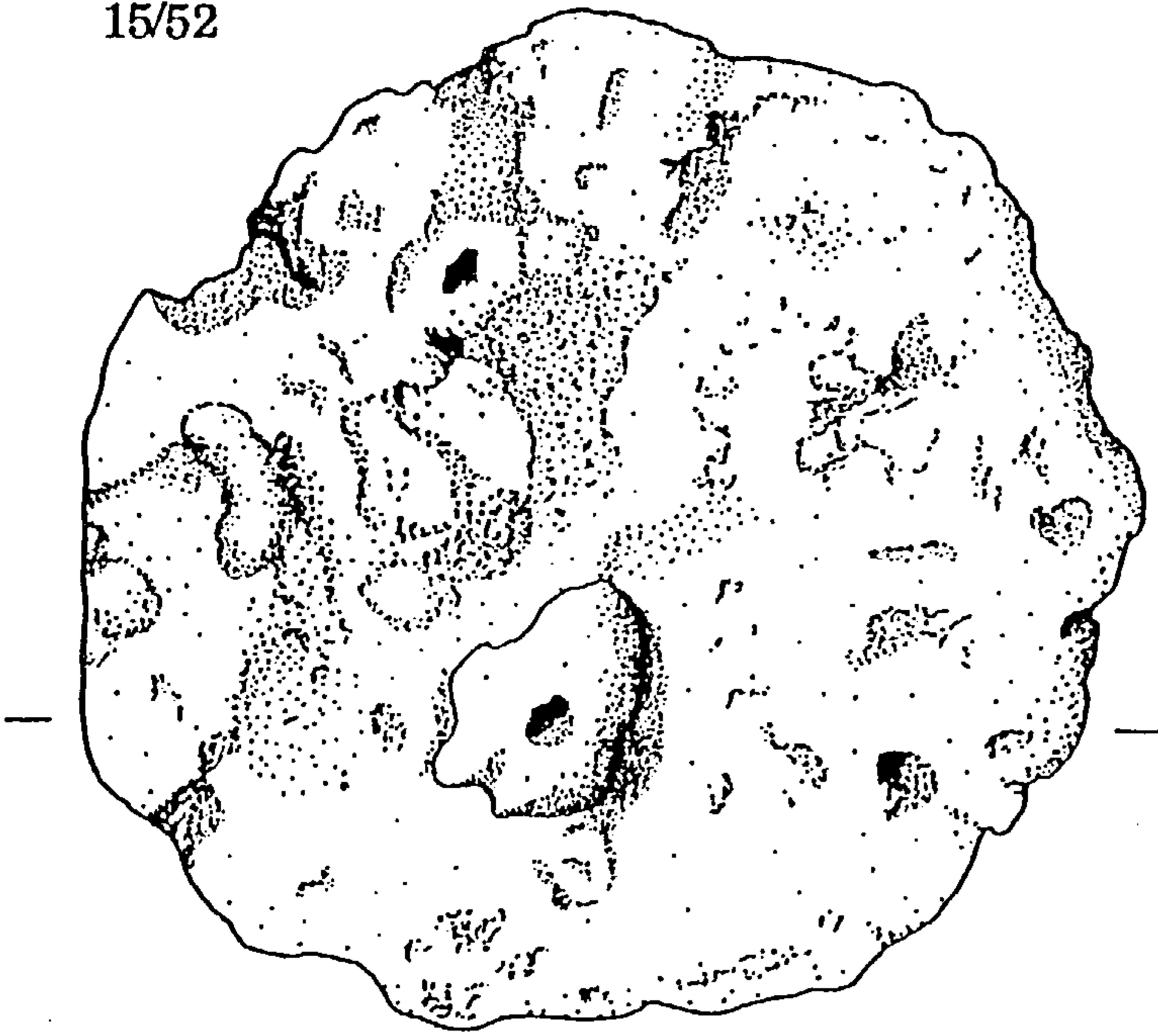


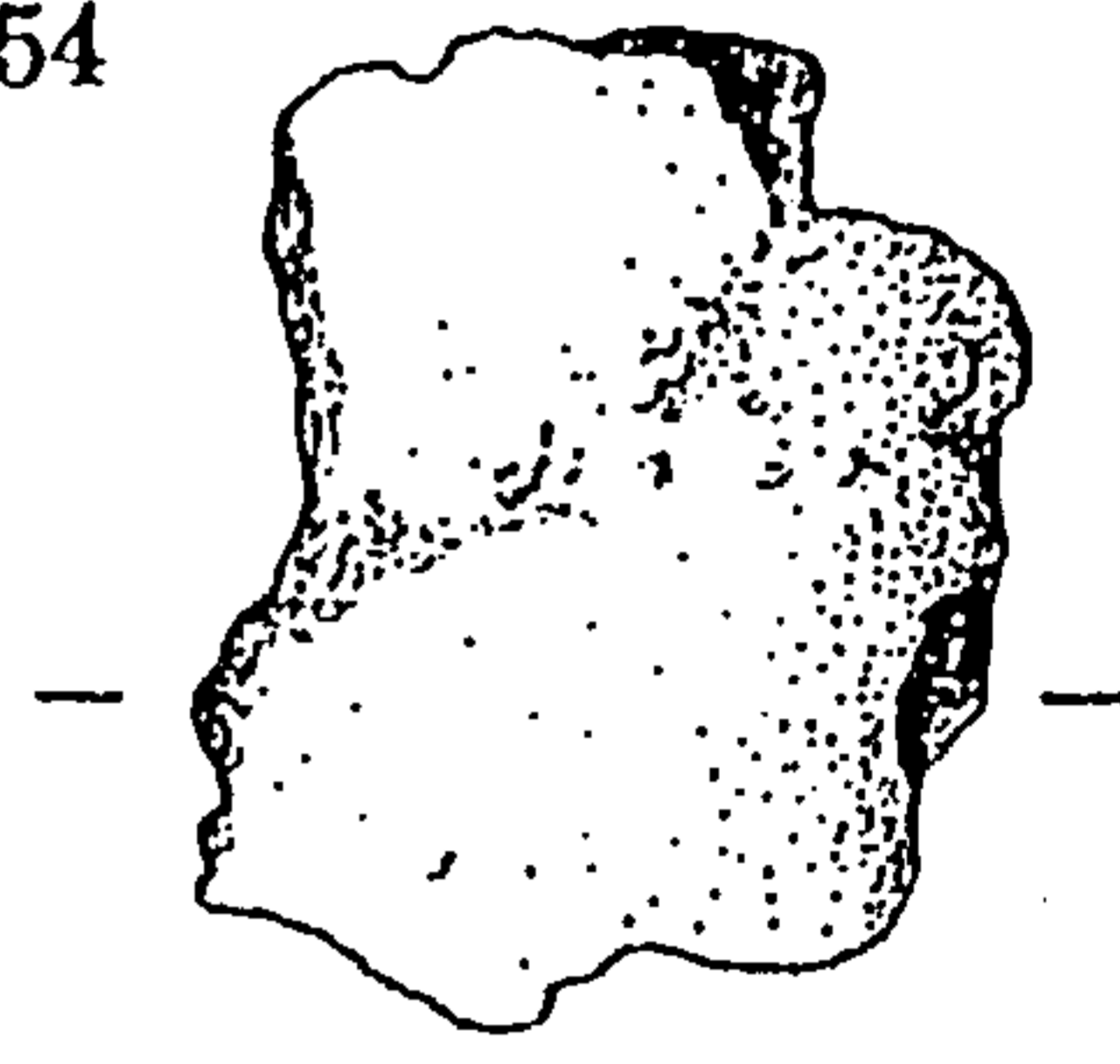
Fig. 20 The Bexley Heath Hoard (Ref. No. 15): Small Tools, Weaponry and Miscellaneous Items

15/52

15/53



15/54



0 2cm

15/55

15/56

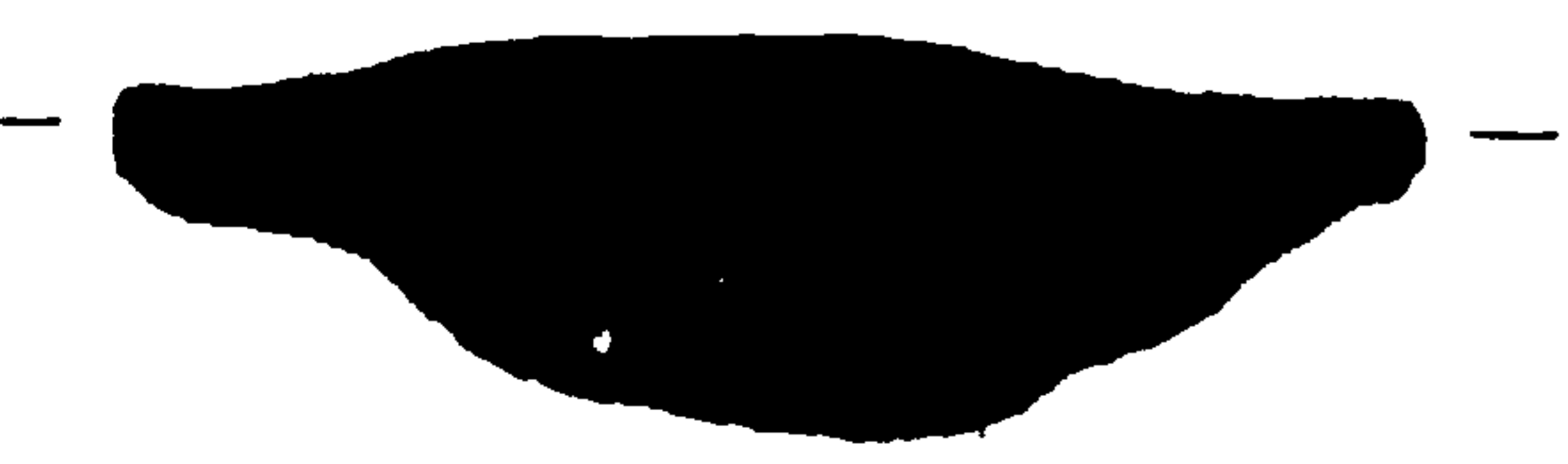
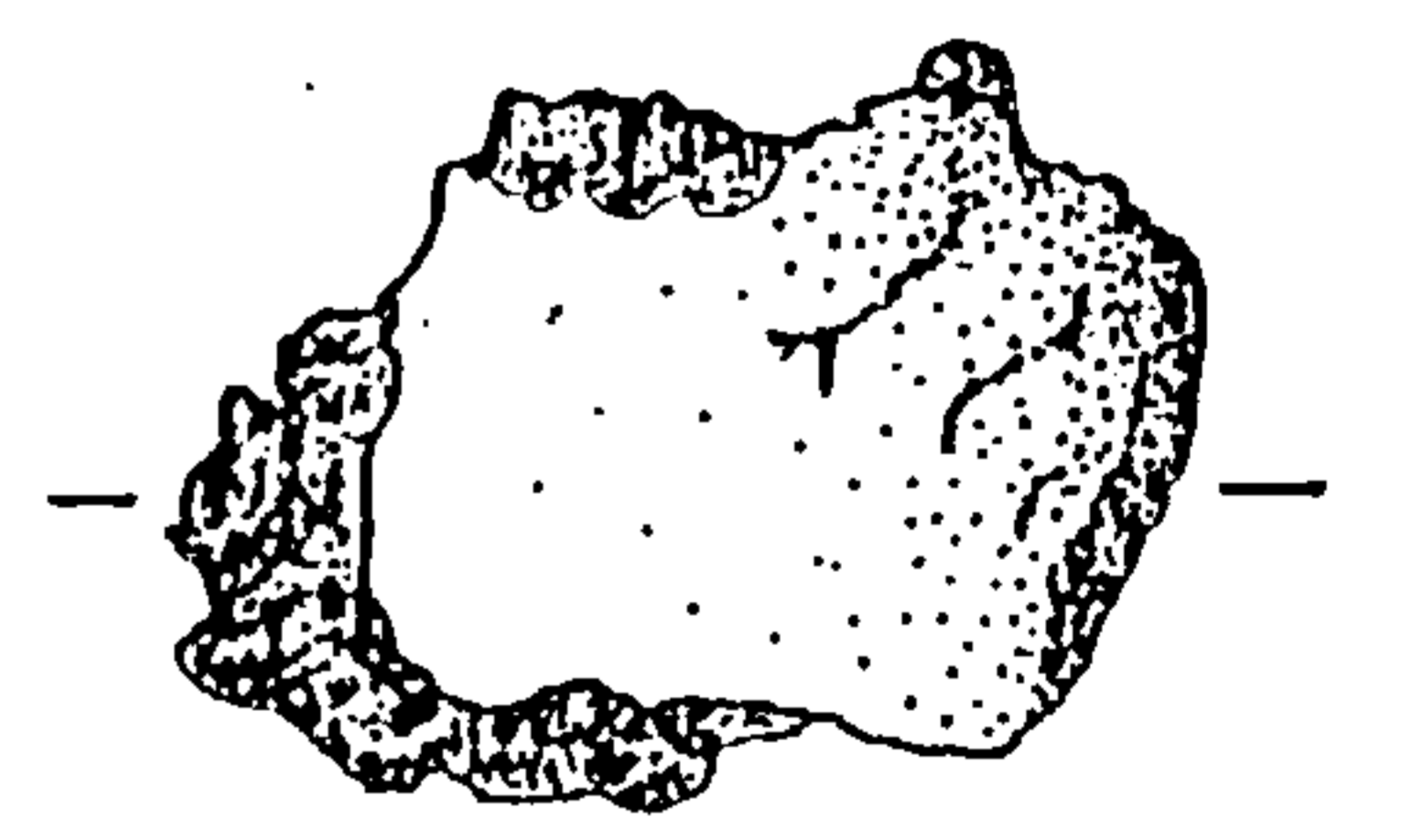
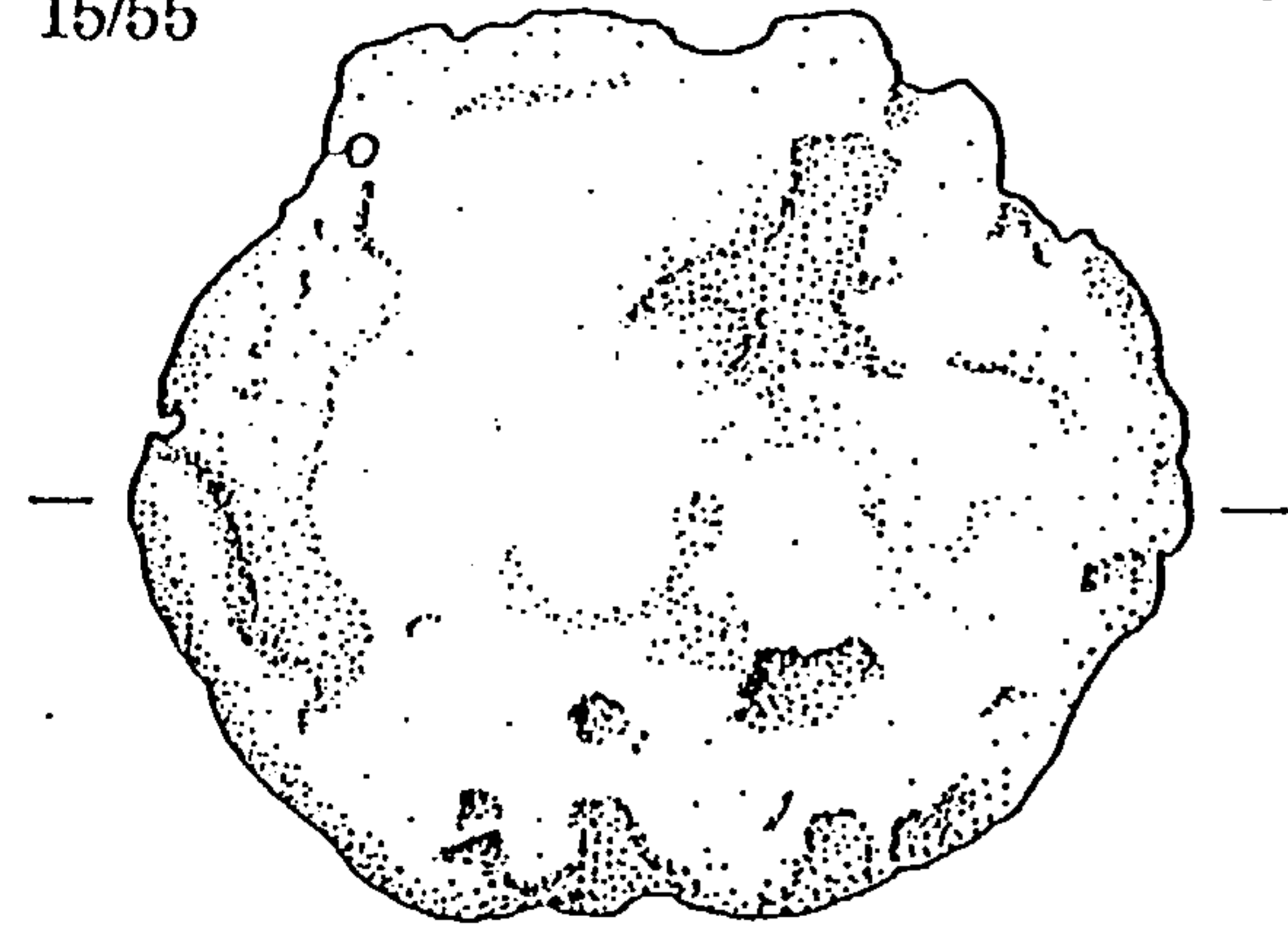
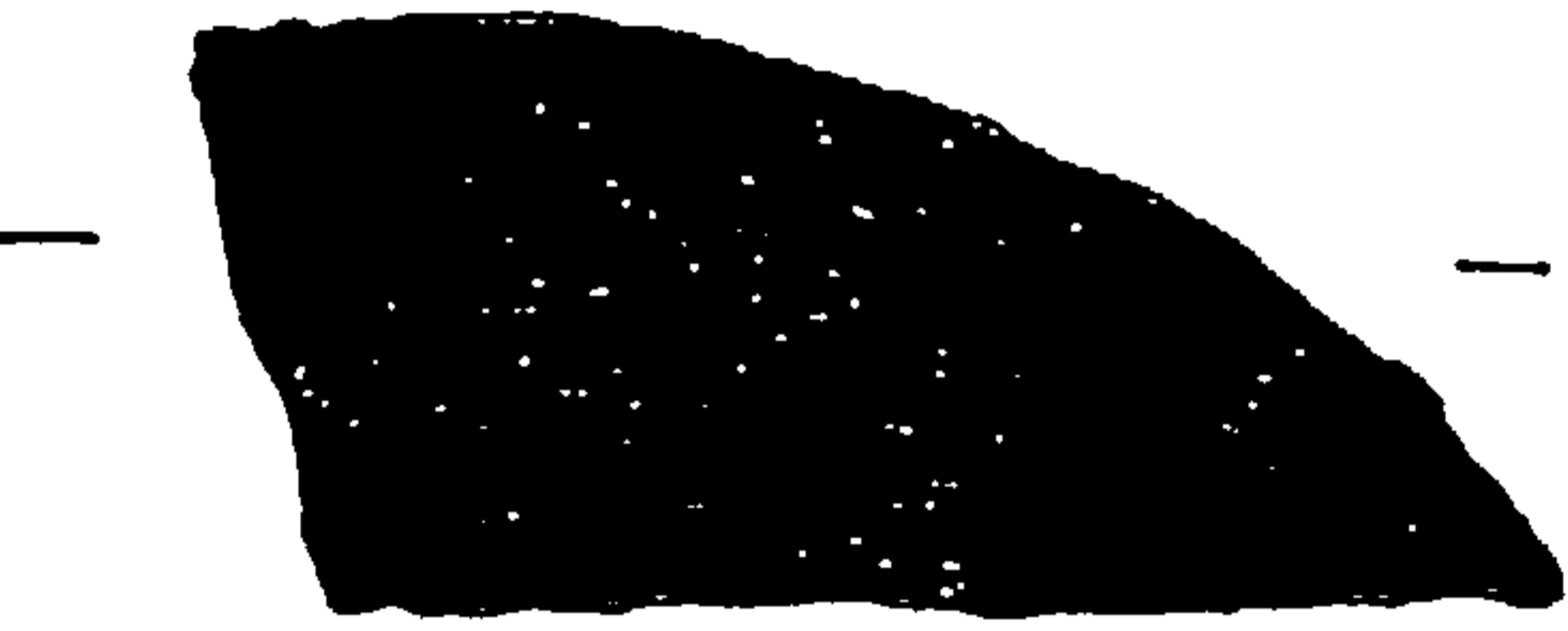
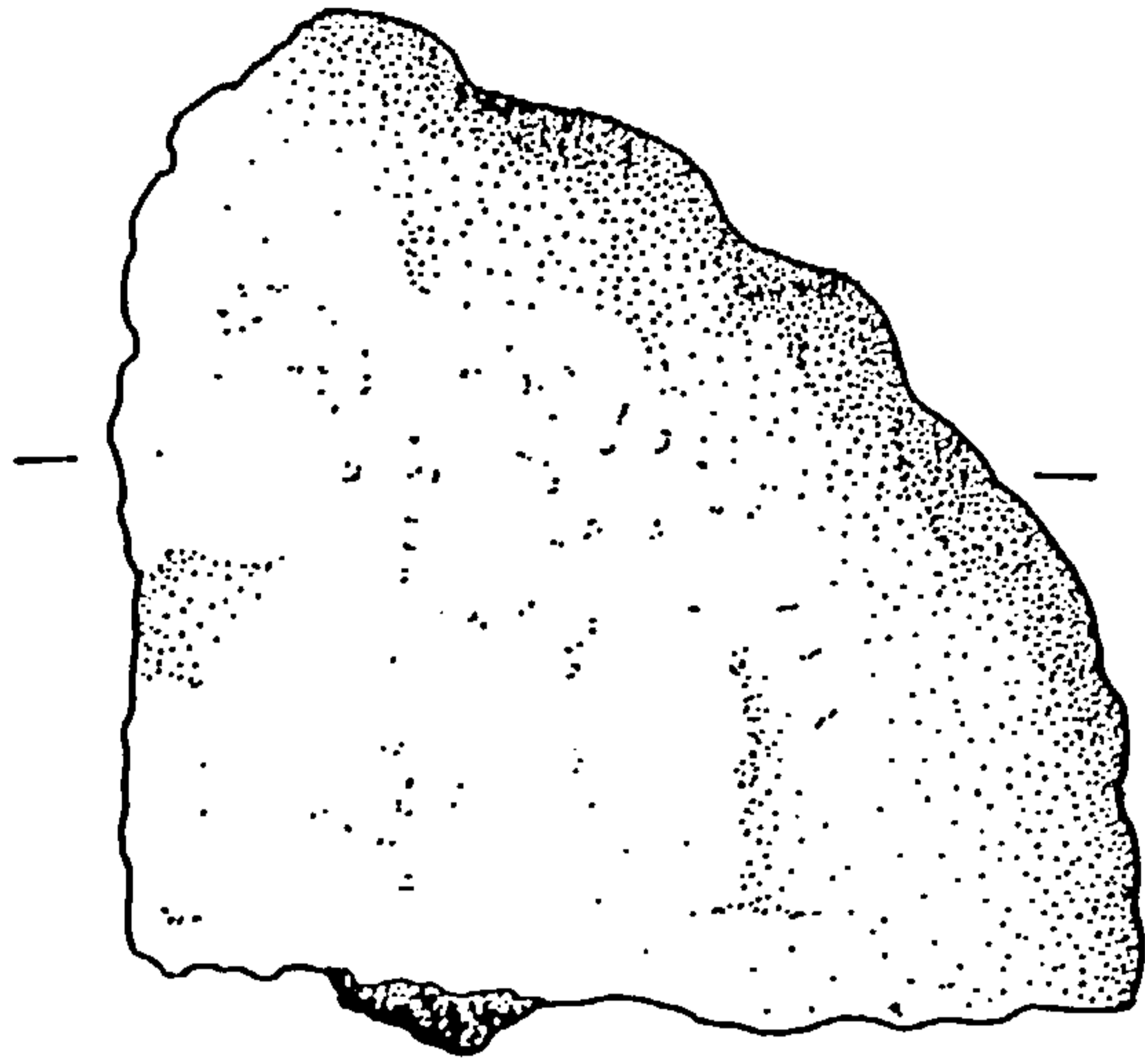
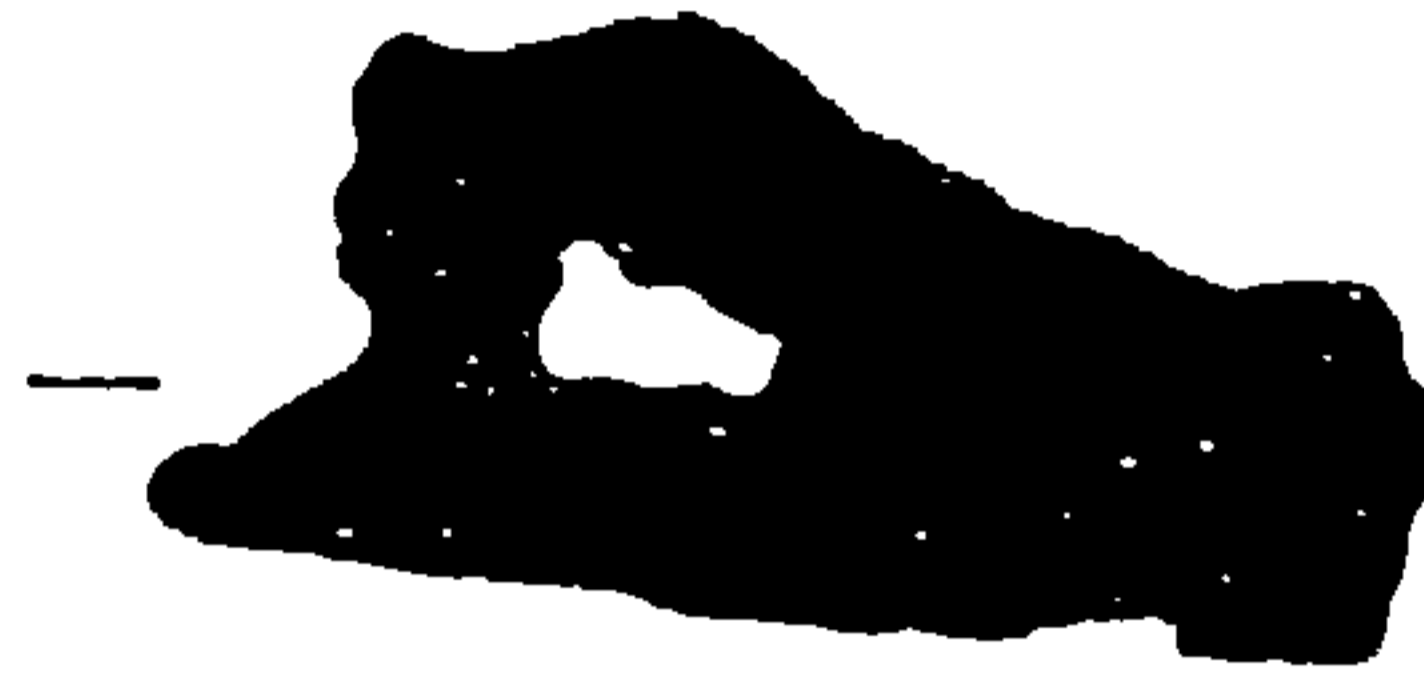


Fig. 21 The Bexley Heath Hoard (Ref. No. 15): Ingot Metal (i)

15/57

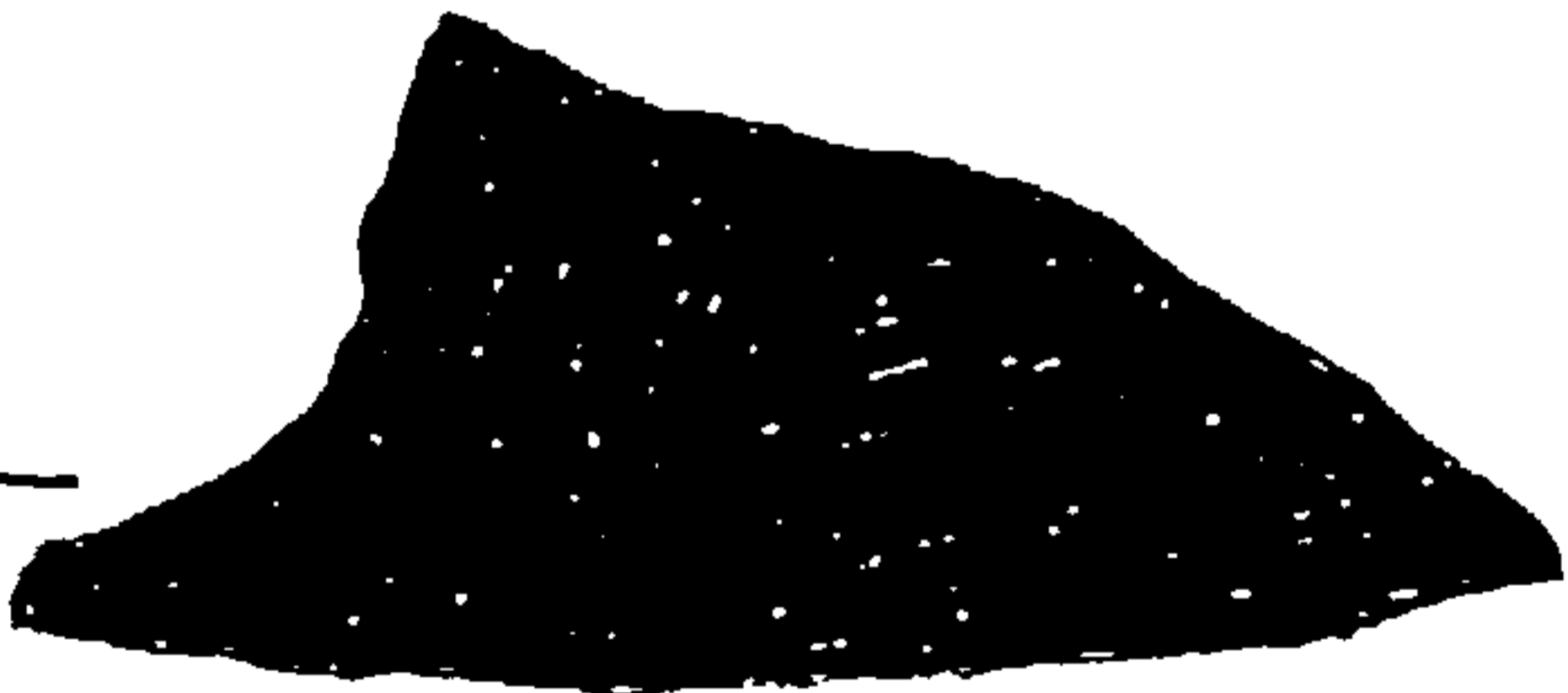
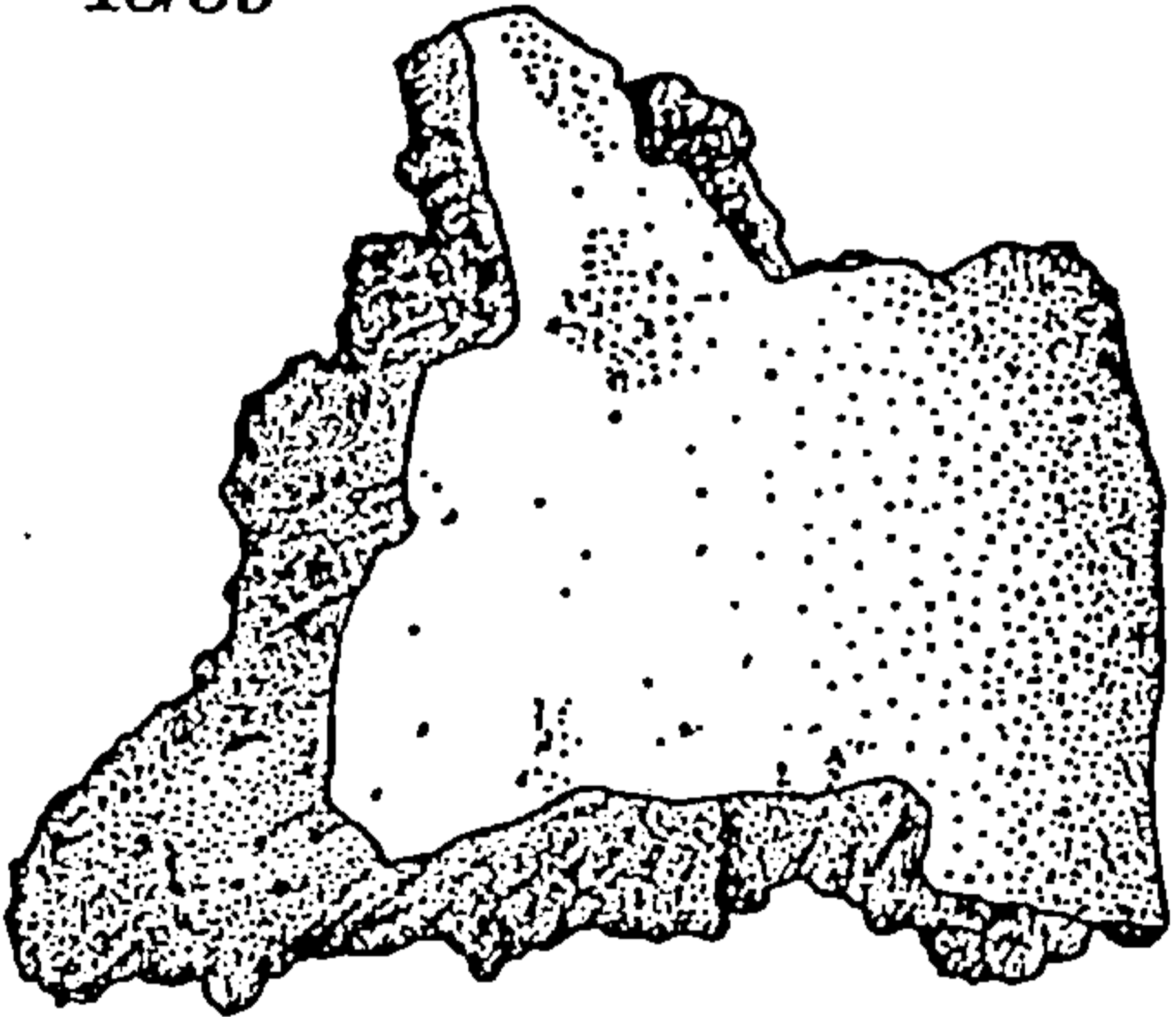


15/58



0 2cm

15/59



15/60

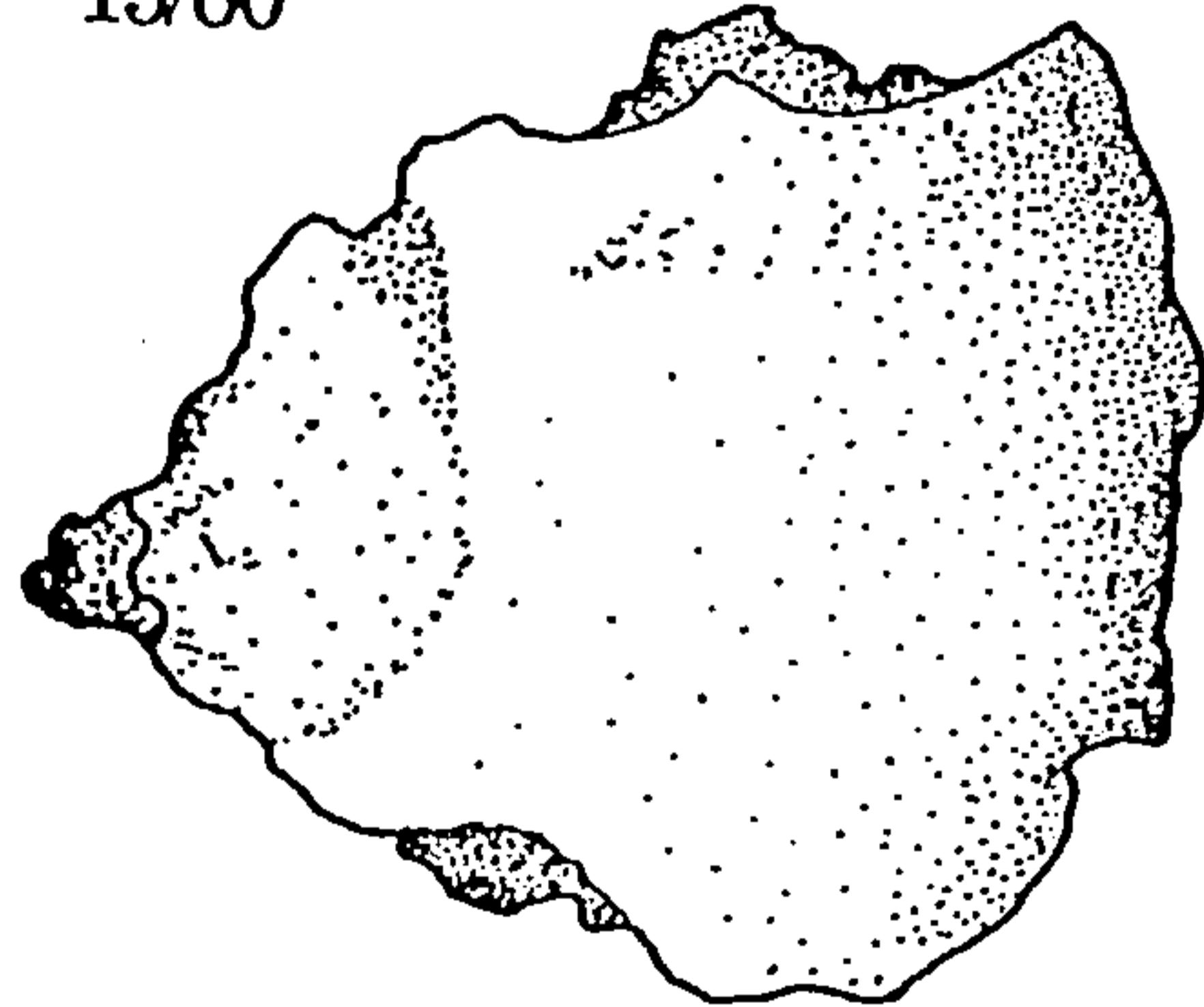
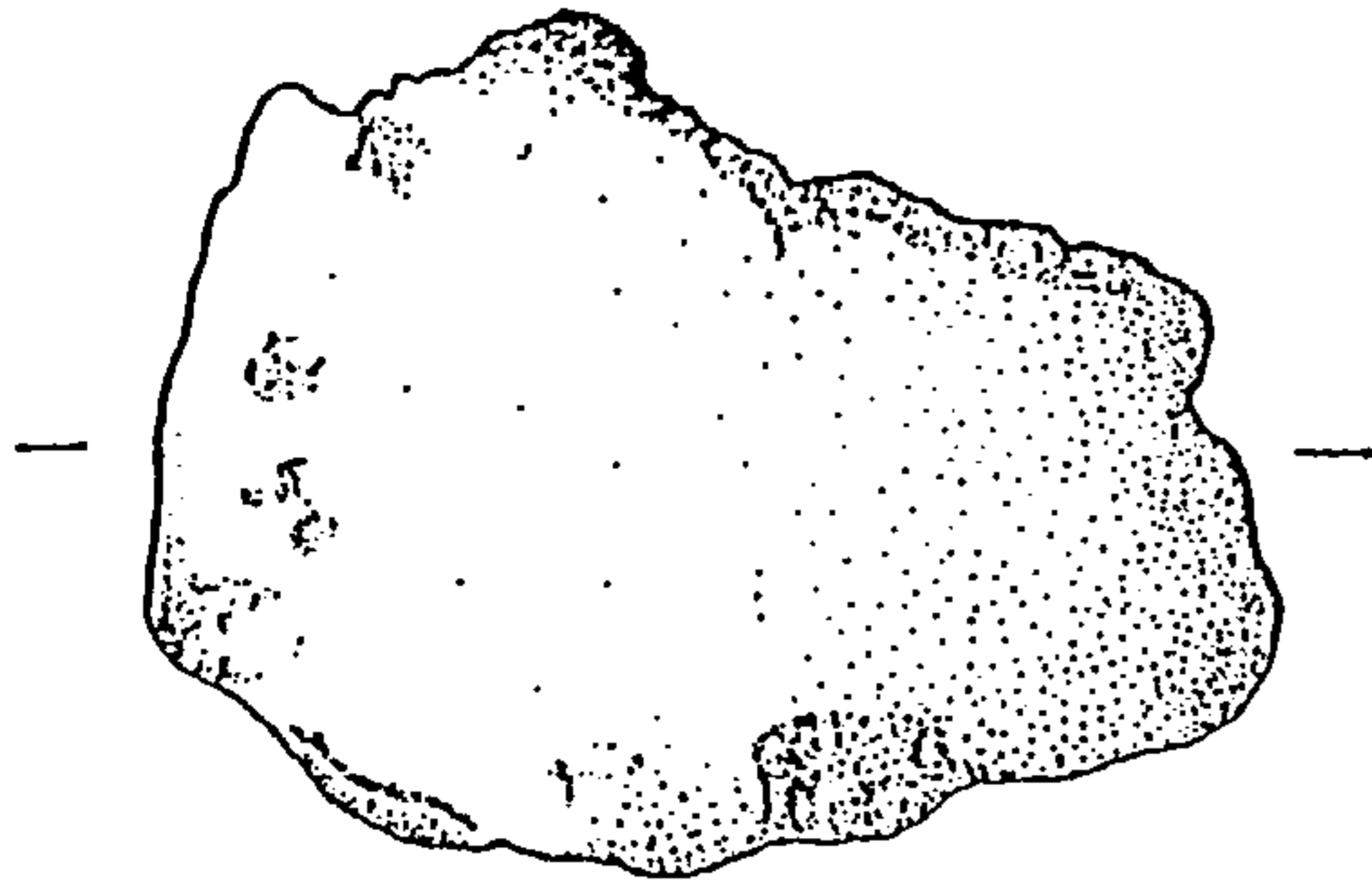
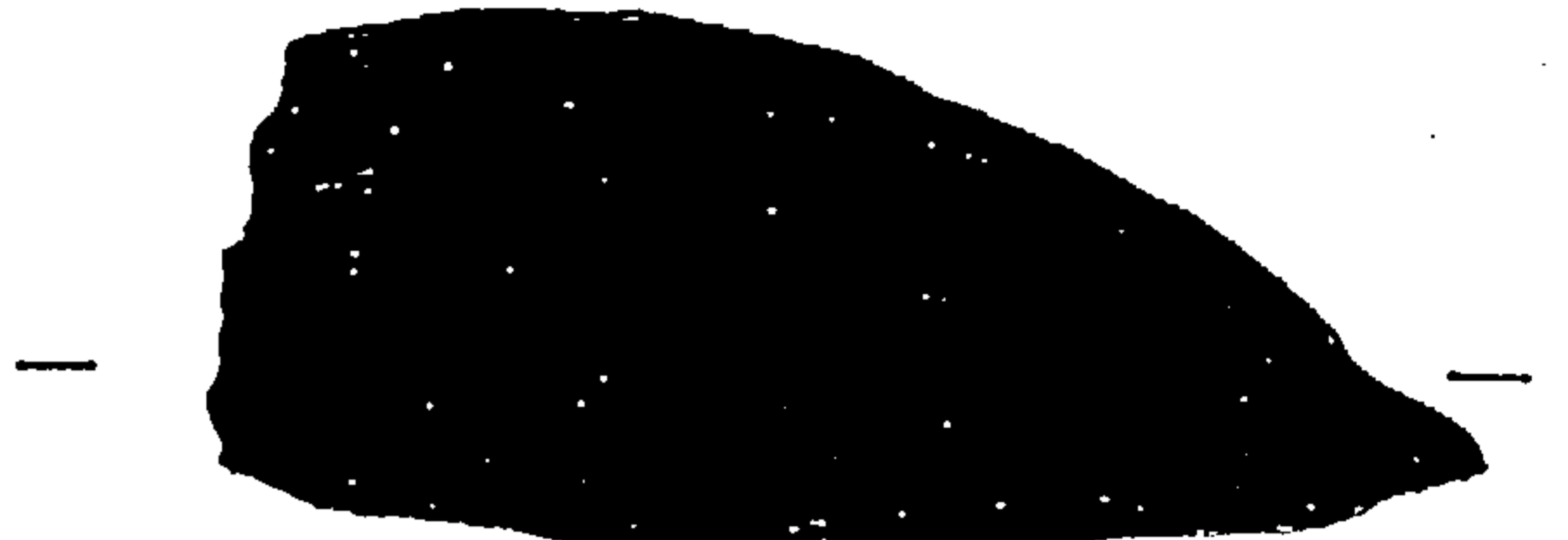
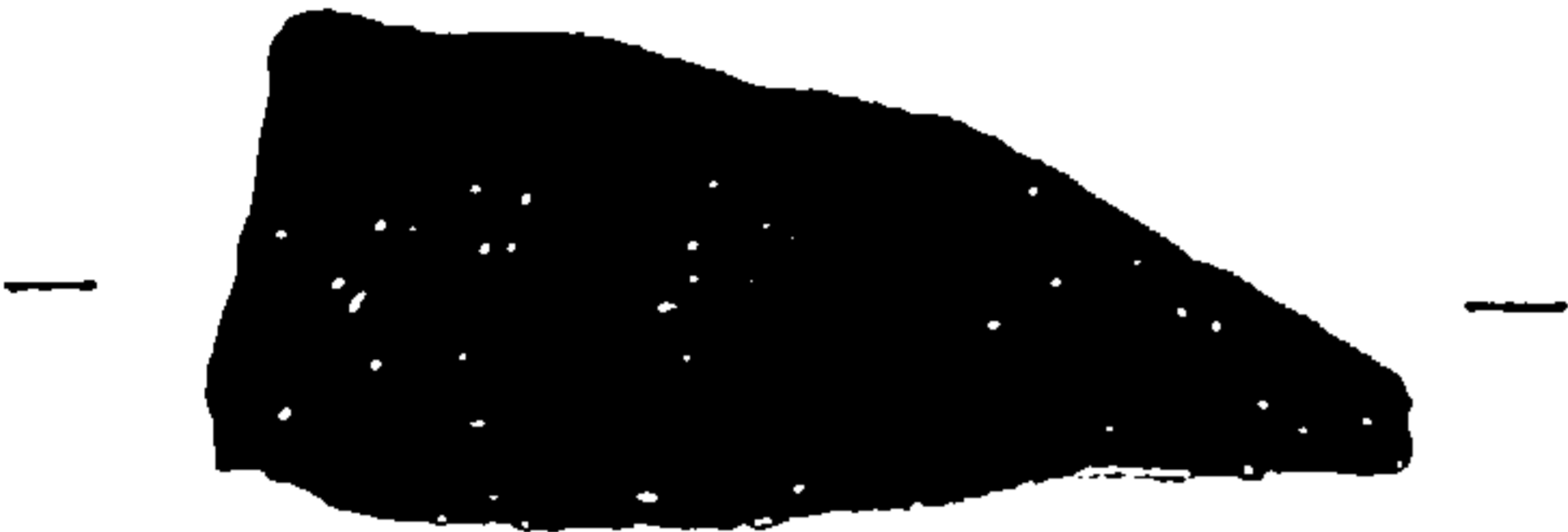
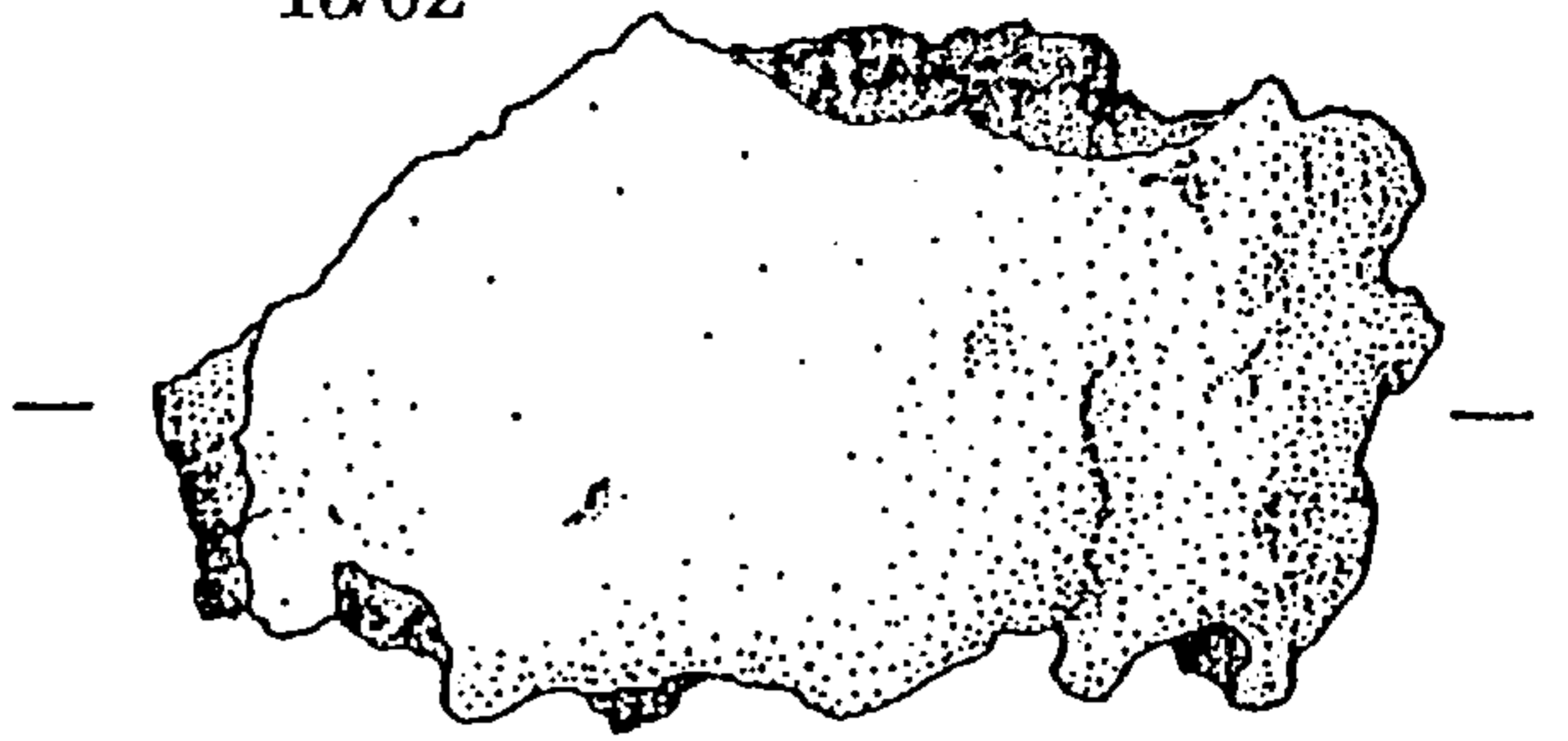


Fig. 22 The Bexley Heath Hoard (Ref. No. 15): Ingot Metal (ii)

15/61

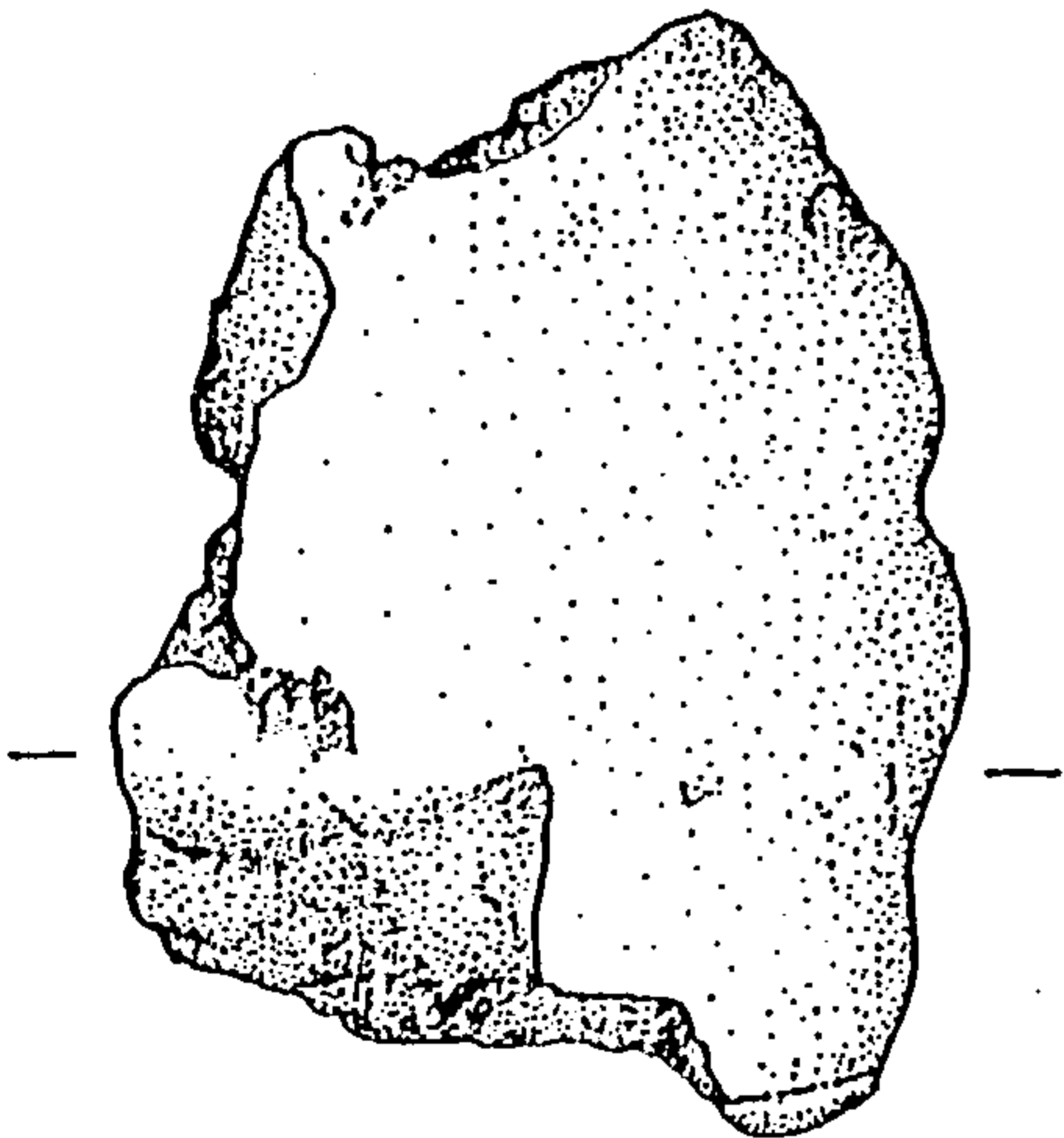


15/62

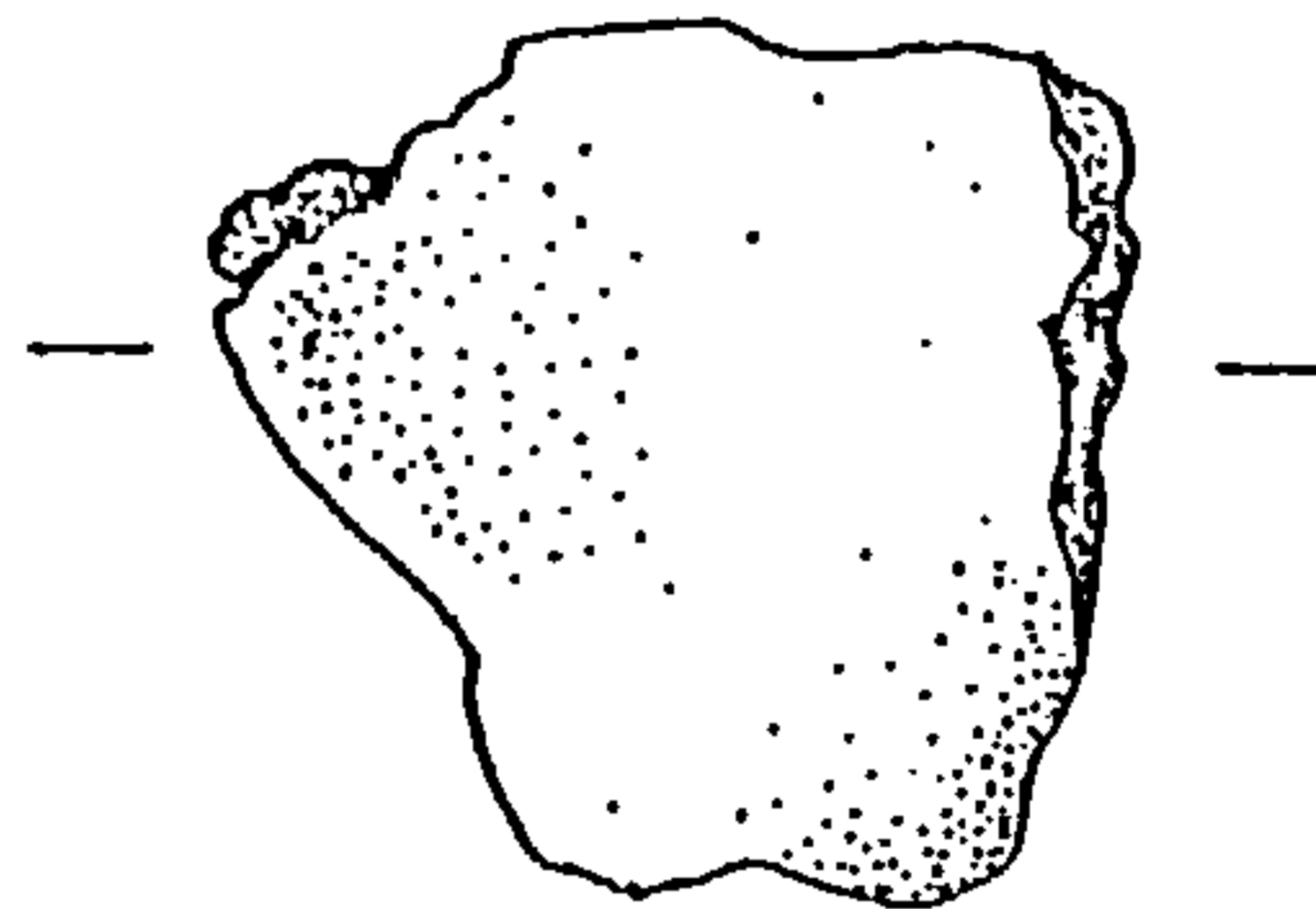


0 2cm

15/63



15/64



15/65

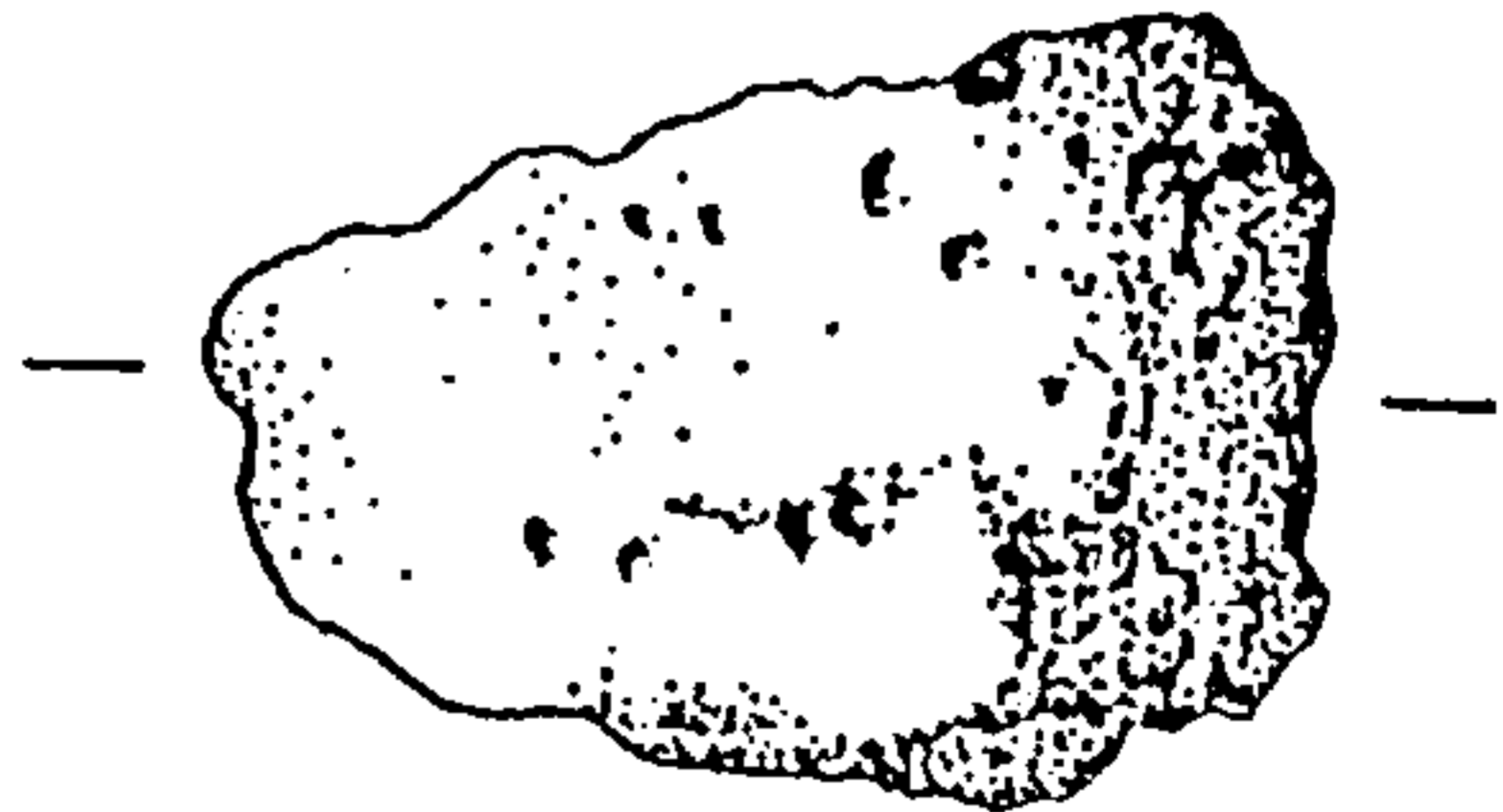
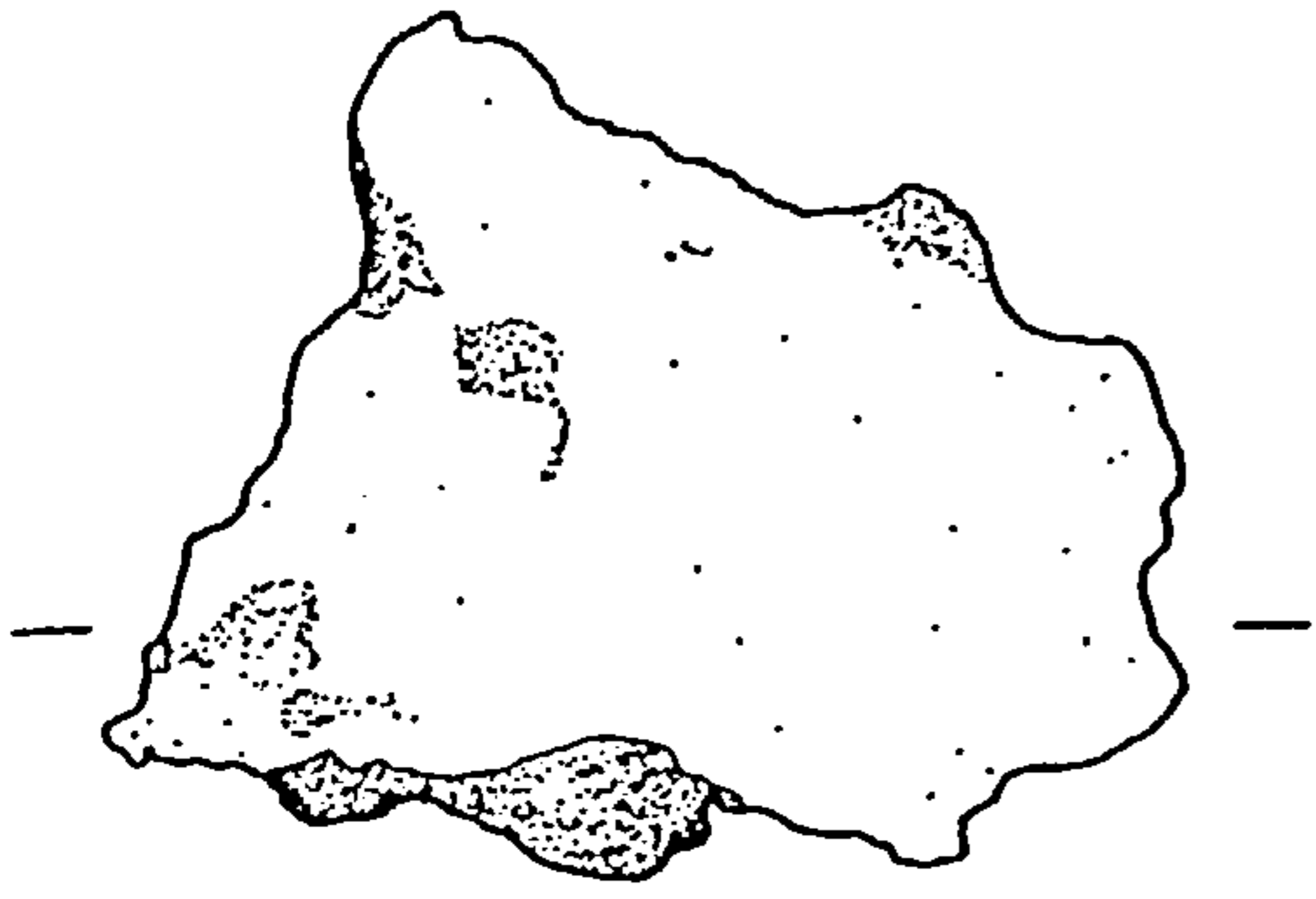
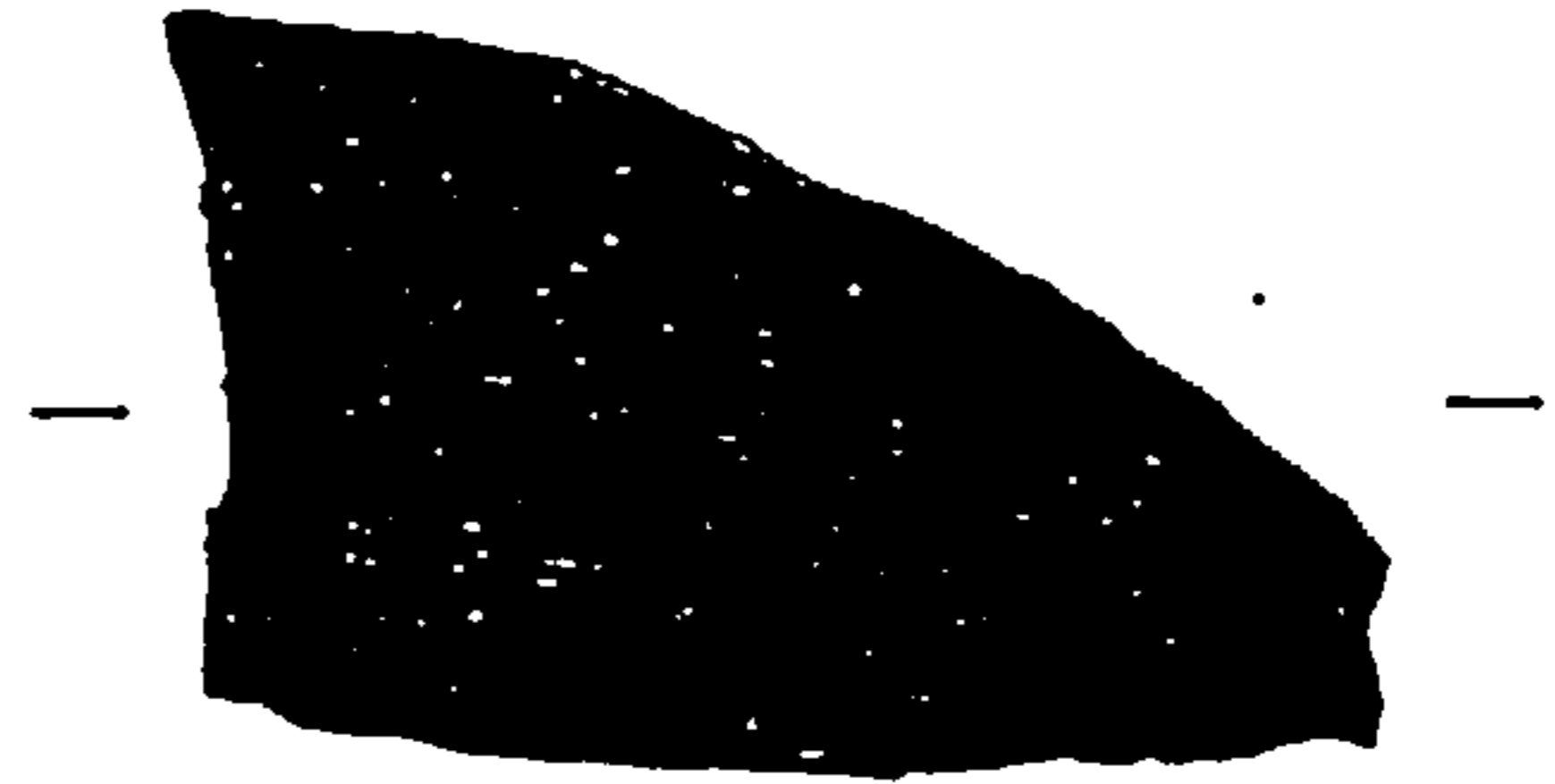
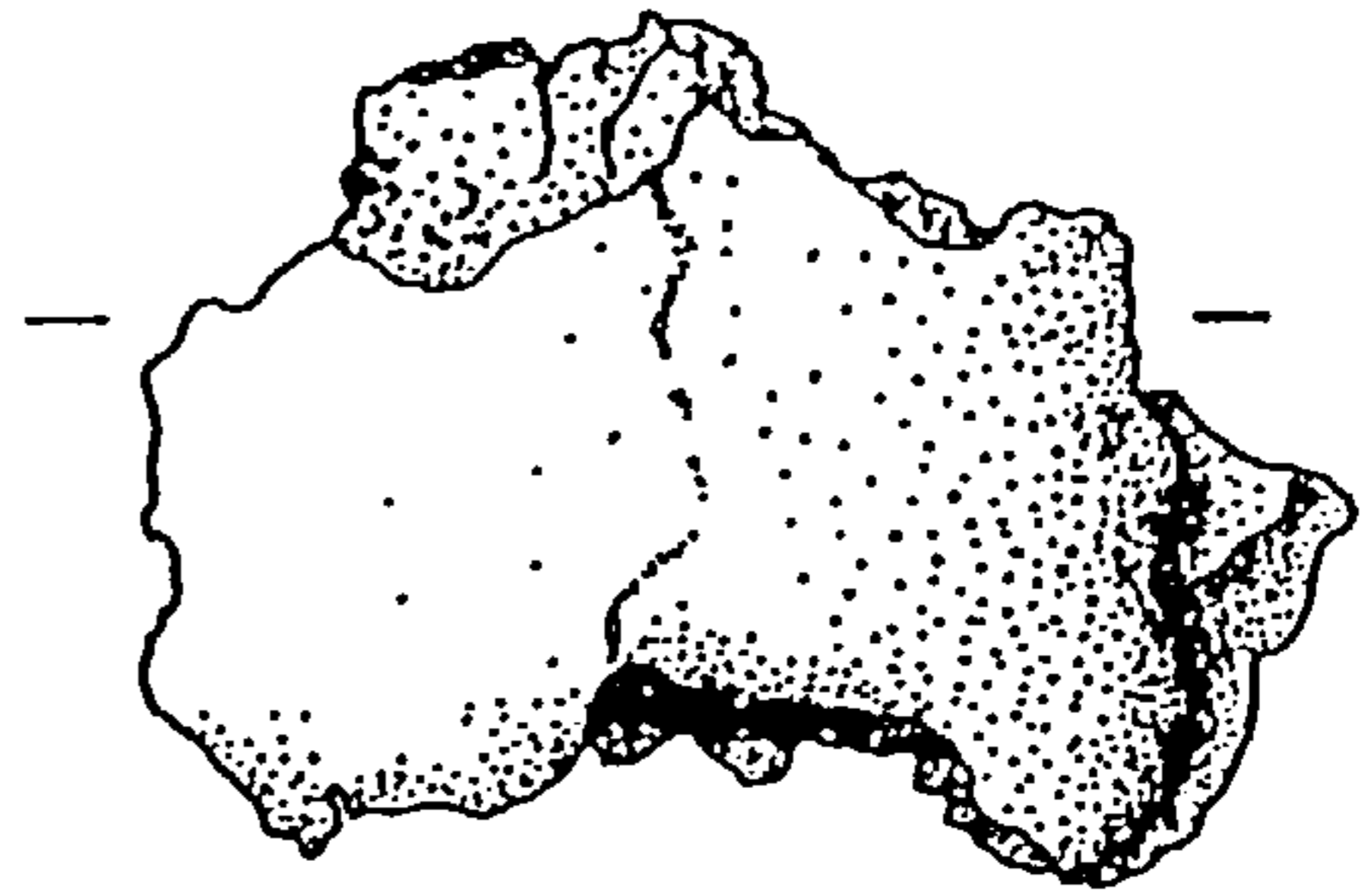


Fig. 23 The Bexley Heath Hoard (Ref. No. 15): Ingot Metal (iii)

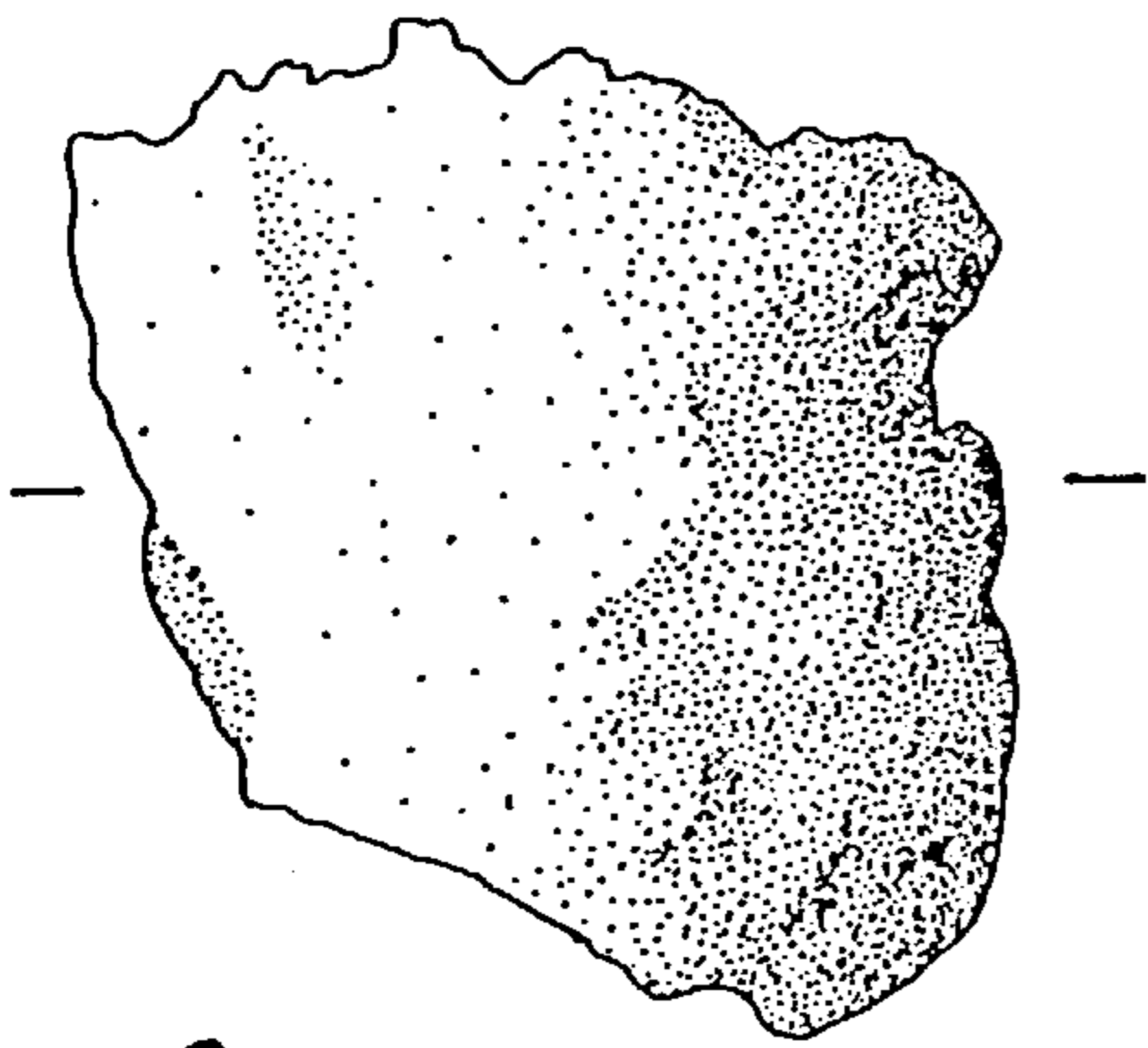
15/66



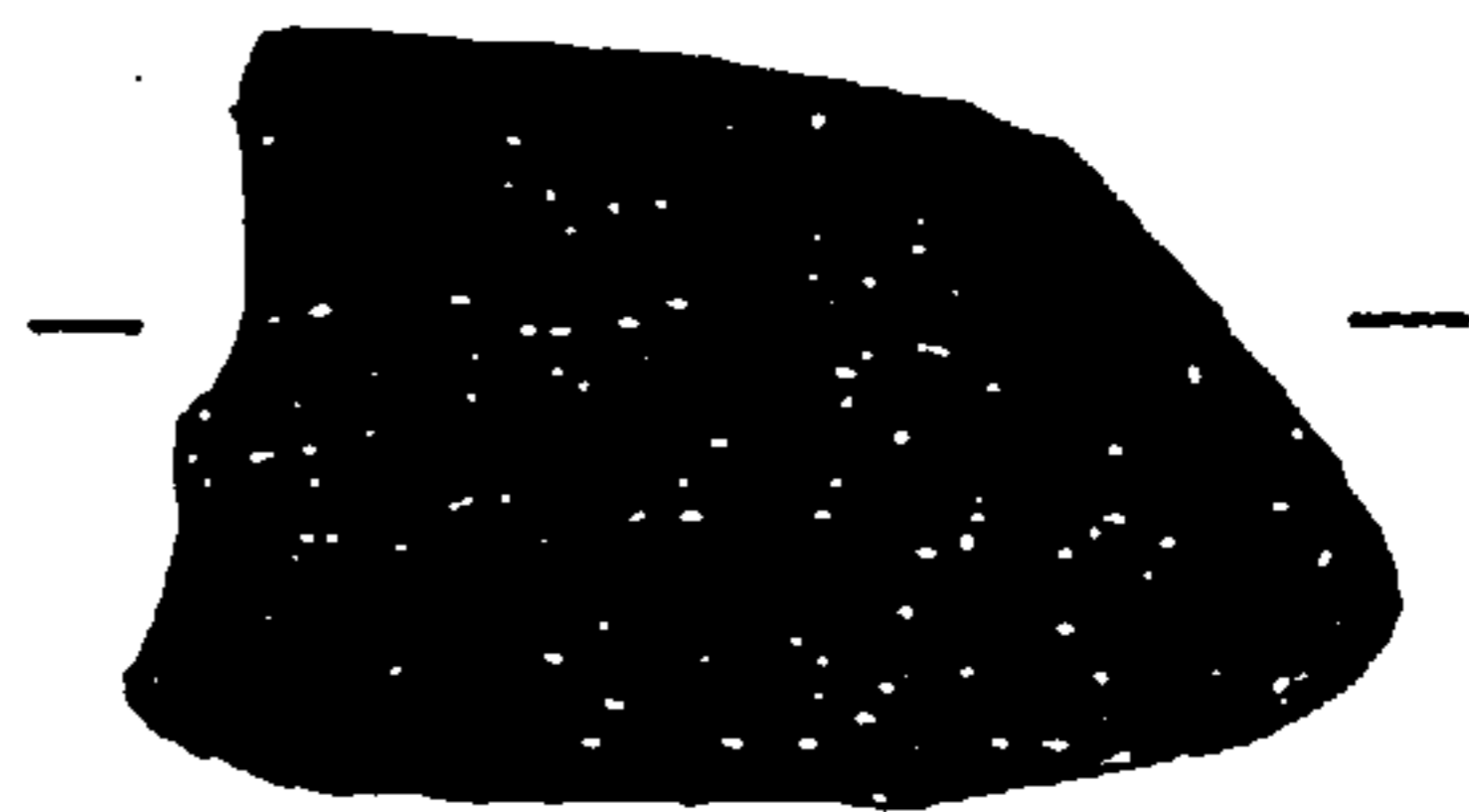
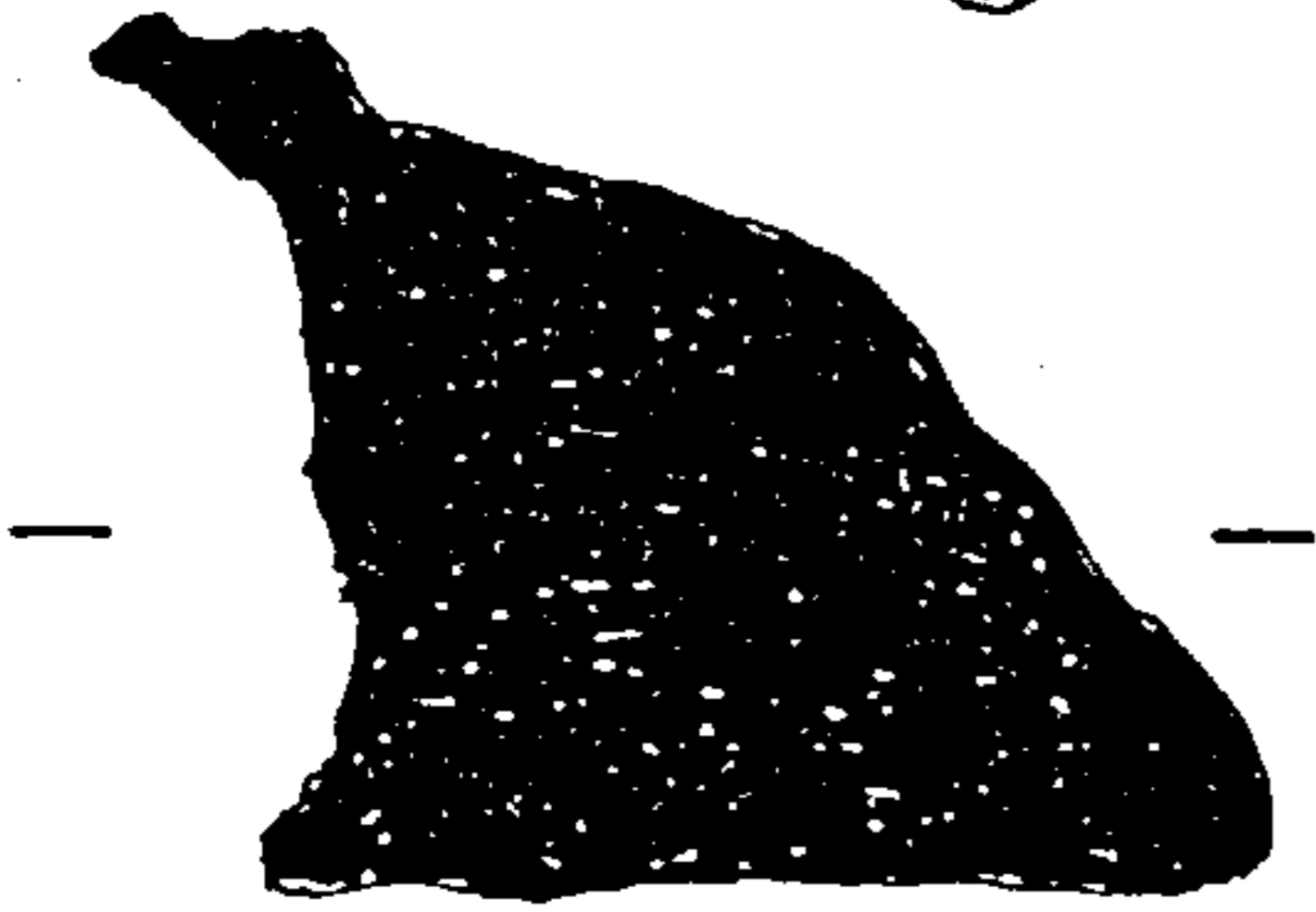
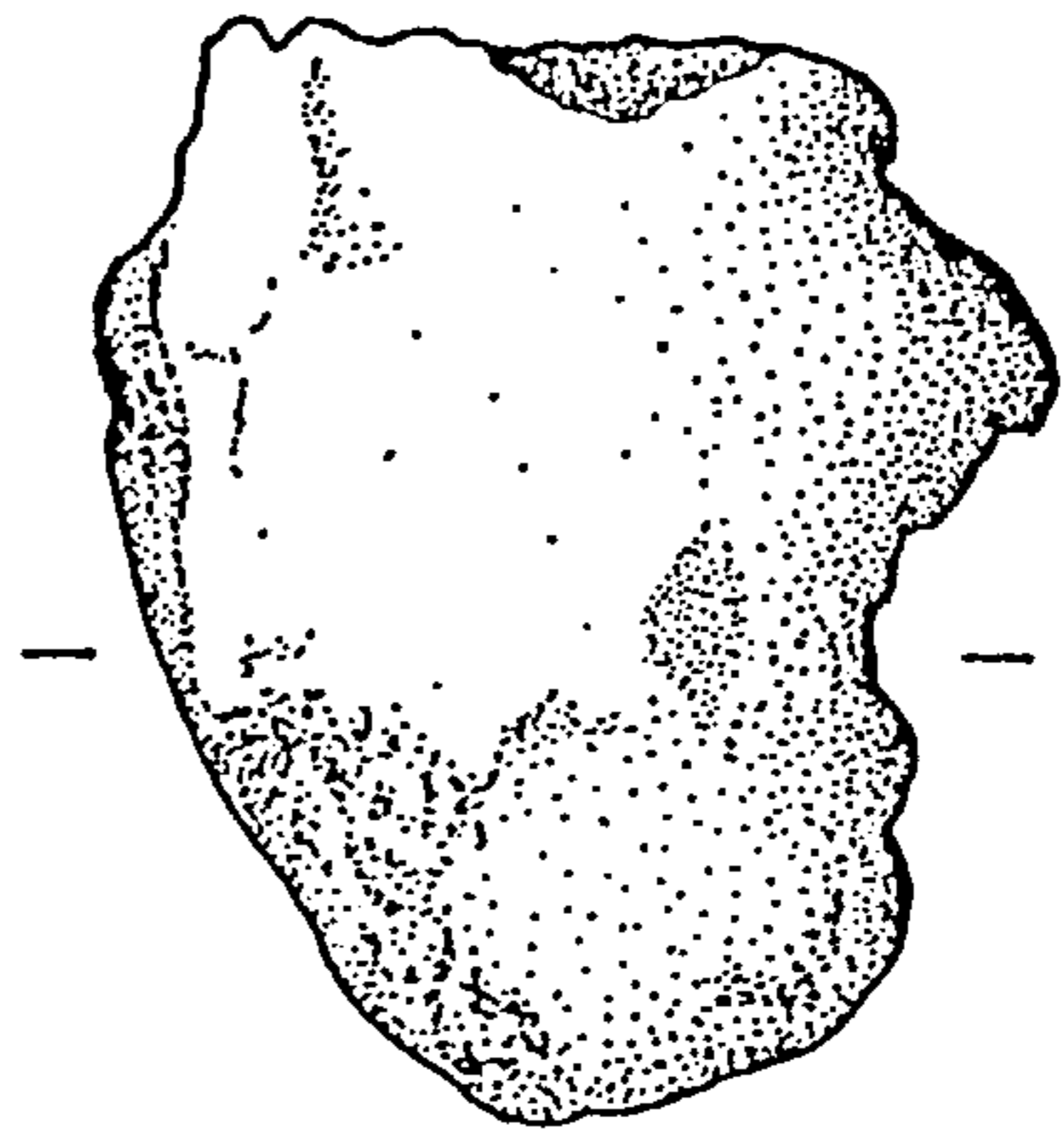
15/67



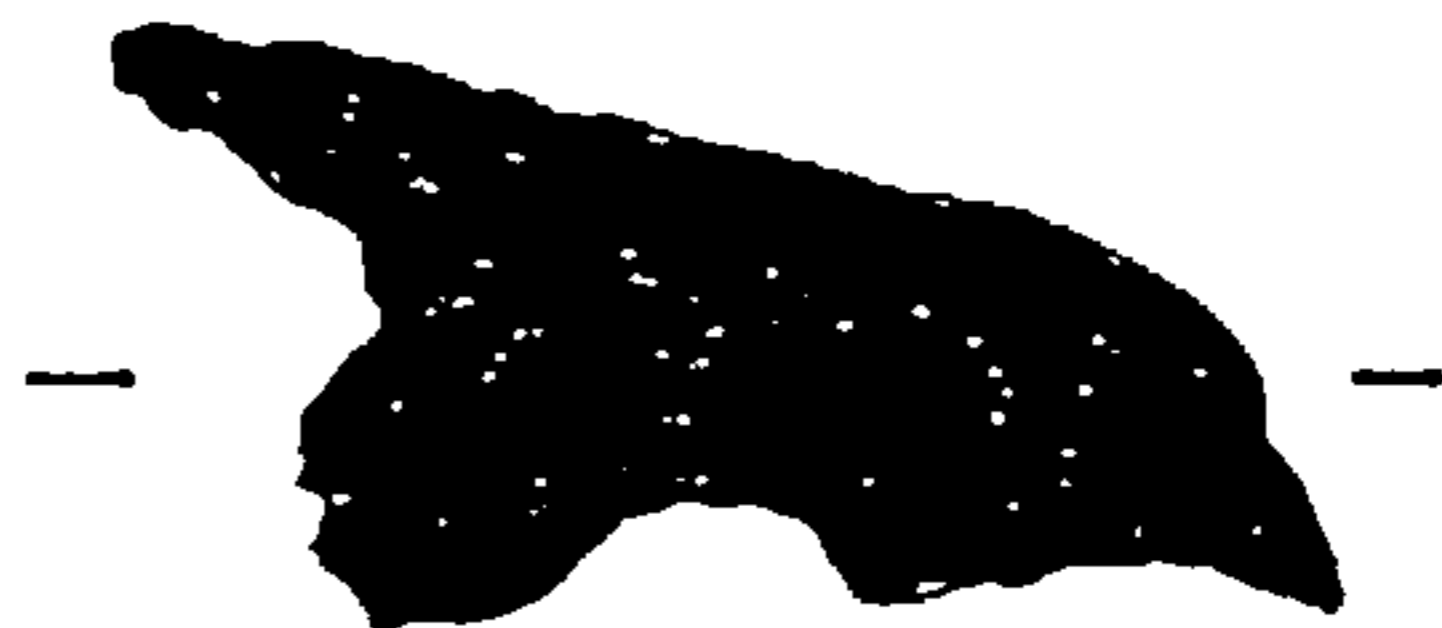
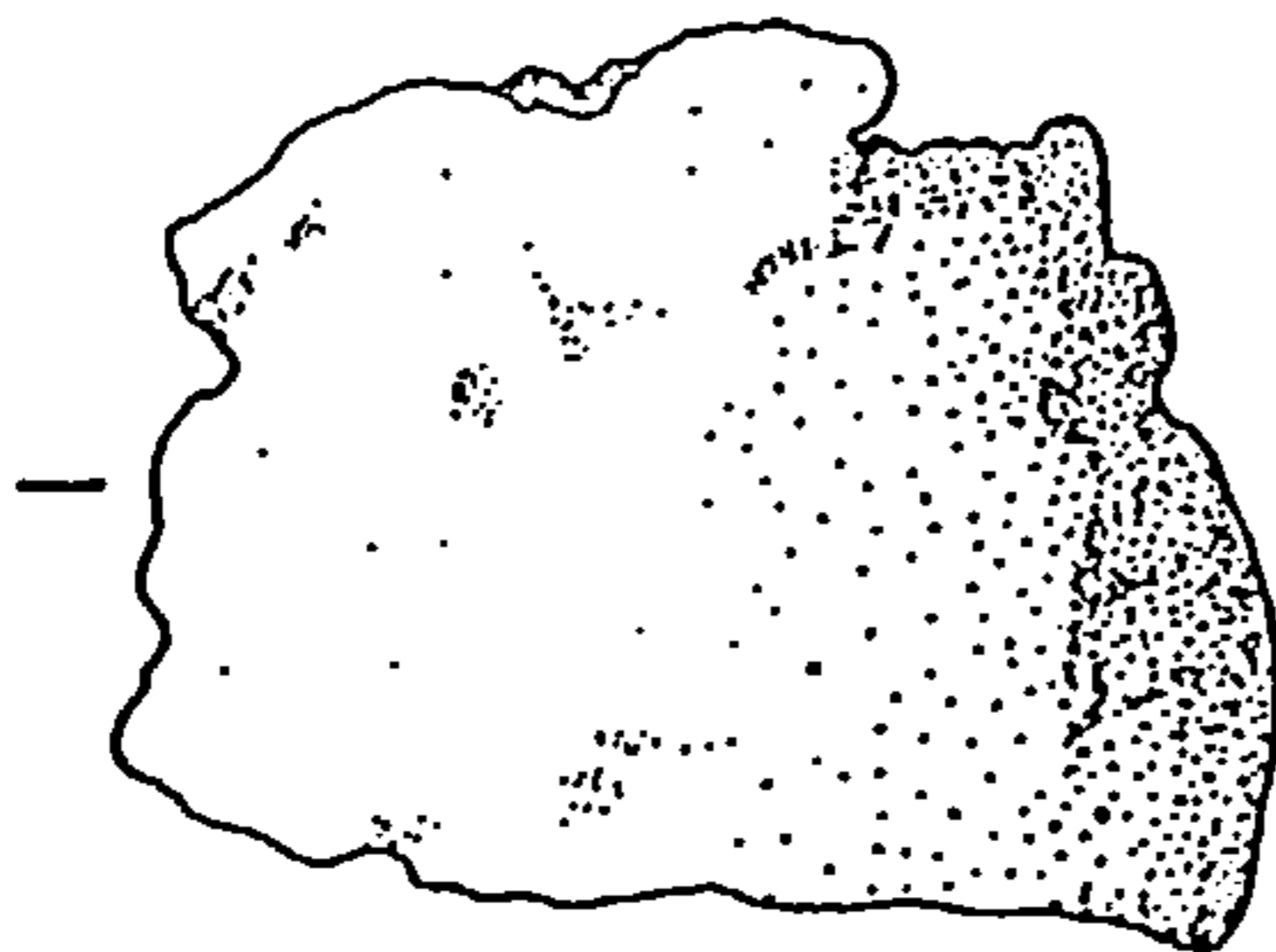
15/68



15/69



15/70



0 2cm

Fig. 24 The Bexley Heath Hoard (Ref. No. 15): Ingot Metal (iv)

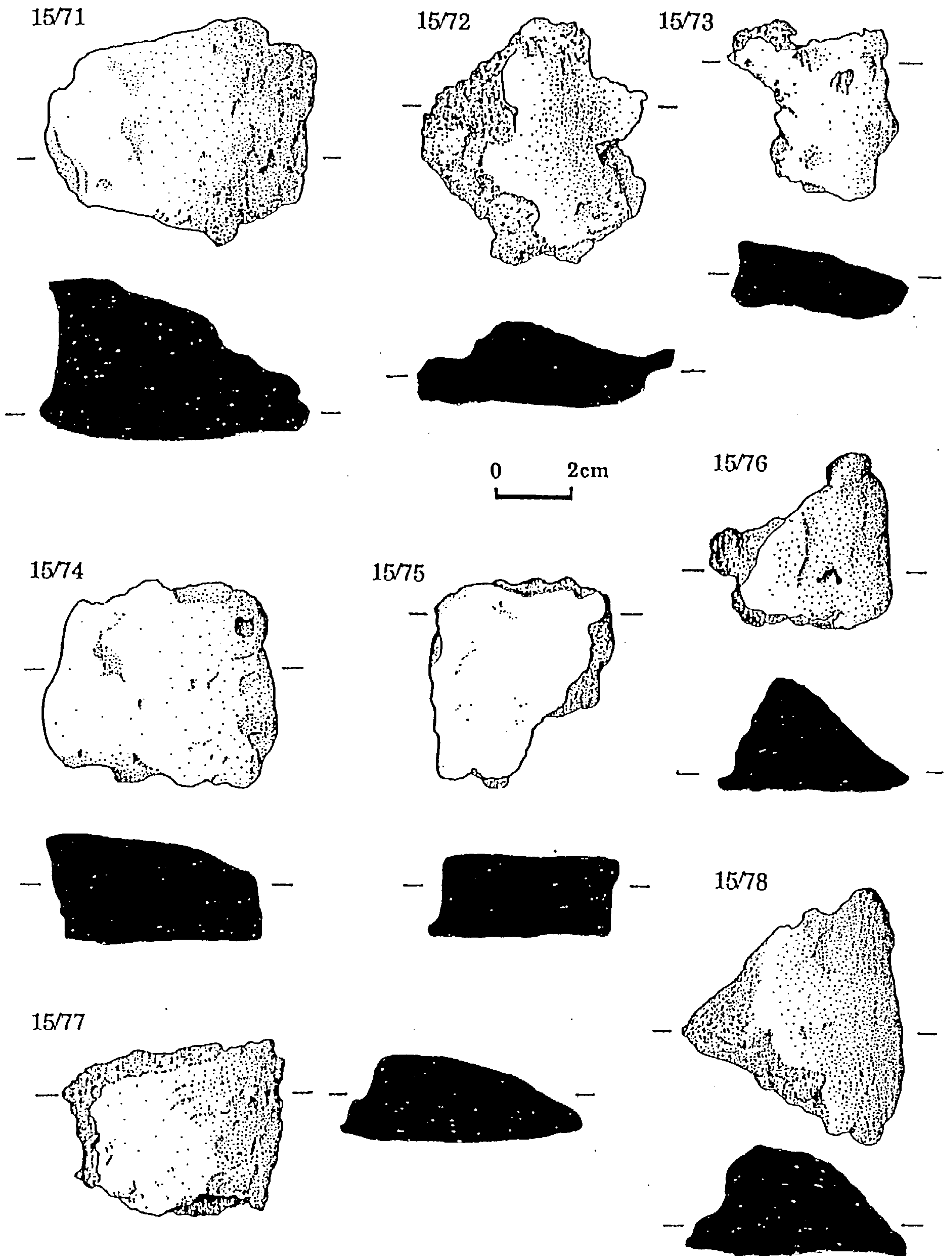


Fig. 25 The Bexley Heath Hoard (Ref. No. 15): Ingot Metal (v)

Borstal (Ref. No. 16)

Grid Reference: TQ 82 75.

Current Location: Maidstone Museum. No accession numbers are marked on these objects.

Context: No further information available.

Bibliography: NBI.

Further Information: No weighing facilities were available at Maidstone Museum, and so no weights are given in association with any of the pieces described below.

Contents:-

16/01

Description: Socketed axe, of 'south-eastern' type, with pendant loop decoration hanging from the lower collar moulding.

Dimensions: Length: 90mm. Cutting edge: 40mm.

Patina: Some bronze showing, with patches of dark and bright green encrustation present. Details obscured in places.

Manufacture: The thickness of the wall seems uneven around the mouth, indicating core misalignment. Near the loop, the metal appears cracked and distorted, and this also seems to be related to a casting defect. The mouth is very uneven, though few traces of any seams are apparent. On the body, the casting seams have been trimmed, though they remain sharp. Over the final c.20mm back from the cutting edge on either side, however, all traces appear to have been removed, though the corrosion product obscures much detail here. The cutting edge, though narrow in appearance, shows bevels over either corner, which suggests that the blade was subject to resharpening at least once in its lifetime.

Use: The corners of the cutting edge are broken, and there are large notches and chips missing from its length, with no stretches of the original edge remaining intact.

Reduction: A large number of small tool marks on the body may have been inflicted during the removal of the material which once bound the axehead to the haft.

16/02

Description: Socketed axe, of undecorated 'south-eastern' type.

Dimensions: Length: 78mm. Cutting edge: 42mm.

Patina: Though some bronze shows, much of the piece is covered with a thick layer of a green/olive patina, with some rough encrustation apparent. Details are largely excellent.

Manufacture: The mouth has a rather uneven appearance, a slight dip here in the vicinity of the break perhaps indicating a casting flaw. One feeder remains visible, and the seam is prominent outside the mouth near the loop. The upper seam appears to have been trimmed, though it remains thin and sharp, but over the last c.25mm towards the blade, it has been flattened, and has been obliterated in the immediate vicinity of the cutting edge. The lower seam is more difficult to assess because of the nature of the corrosion product. Some traces remain over the collar, as do possible indications further down the body, though it appears to have been obliterated over the loop and also immediately above the cutting edge. Horizontal grinding marks can be seen on both faces over the cutting edge, which appears well expanded. Some diagonal grinding marks, present further up the piece on the lower collar moulding, appear to have originated in recent times.

Use: The cutting edge appears very blunt and badly chipped. However, some of this damage may be due to the flaking away of corrosion products in more recent times. One small fragment is now missing from the mouth, and since this break is associated with a likely casting flaw it seems feasible to suggest that this breakage was use-related damage resulting from an inherent weakness in the casting.

Reduction: There are chisel marks visible on the collar and the upper body, and these may relate to the removal of the haft. The base of the socket appears to have been infilled with copper alloy, and a tiny fragment of copper cake lies above this. The latter fragment is not wedged in place, instead appearing to adhere firmly to the metal, perhaps through inclusion when the metal was still cooling, or perhaps through later build-up of corrosion products.

16/03

Description: Incomplete socketed axe of 'south-eastern' type, with much of one face and the adjoining upper surface now missing.

Dimensions: Length: 113mm. Cutting edge: 41mm.

Patina: Some bronze showing, with rough patches in places.

Manufacture: The mouth seems somewhat uneven, and in the vicinity of the break, the wall appears thin, indicating core misalignment. The upper seam, where surviving, remains quite prominent over the body. It appears to have been trimmed, but has been flattened only over the final c.20mm towards the cutting edge. The lower seam seems to have been flattened over much of its length, though it remains prominent over the collar mouldings. Some horizontal grinding marks are evident over the cutting edge, which has a narrow appearance, and some vertical grinding marks run down the length of the body.

Use: The edge is virtually absent, with only one corner remaining. It appears to have been very unevenly worn.

Reduction: Hammering is apparent on the complete face, and there are also pronounced hammer indents on the other face, concentrated at the point where the solid section of the blade gives way to the socket (illustrated). On this same face there are also possible hammer indents on the collar, and two punch marks situated just above the loop.

16/04

Description: Mouth and upper body of faceted socketed axe.

Dimensions: Length (maximum): 75mm.

Patina: Thick dark green, with some rough patches in places, while in others some bronze remains visible. Details good.

Manufacture: There are indications of core misalignment, but this does not appear too serious. Vestigial traces of the loop are present, but whether its absence is the result of a casting defect or later removal cannot be ascertained. Its remains appear smooth, however, as if subject to deliberate finishing. The seams are well-finished over mouth and body, and though they remain visible and sharp over the collar mouldings, elsewhere they have been flattened and virtually obliterated.

Use: Impossible to determine.

Reduction: The cutting edge is now missing, and cracking in the bronze directly above this point probably results from its removal. No associated indentations are evident, though a series of rough indents on one face (not illustrated) may be linked with this. The piece is now jammed full of objects and rough bronze, including:- i) a tiny fragment of curved metal, probably from a socket, and specifically - from the thickness of the metal - a spearhead socket; ii) a mouth fragment of socketed axe; iii) an unknown fragment, possibly a shoulder fragment of a sword; and iv) another unknown fragment - with a squarish appearance to the section and traces of a casting seam surviving - which might conceivably be a much-distorted socketed gouge fragment.

16/05

Description: Large portion of 'south-eastern' type socketed axe, minus blade, with faint wing decoration apparent on either face.

Dimensions: Length (maximum): 78mm.

Patina: Dull dark-green, with details largely good, though some patches of rough encrustation do obscure a little detail.

Manufacture: One wall is thinner, indicating core misalignment. The seam has been neatly trimmed around the mouth, though the faint bulge of one feeder remains visible. On the body, the upper seam has been flattened considerably, but it still remains visible along the length of the fragment. The lower seam is similar, though it has been virtually obliterated over the lower collar and some of the loop.

Use: Impossible to determine.

Reduction: This piece has been hammered in the area of the lower body, resulting in a marked indentation, and subsequent breakage. Coarse grinding marks are evident which appear to postdate the indentation, as they are superimposed upon it, and their purpose is unknown. There are some marked notches apparent over the upper collar, too. These

appear to be too substantial to have been made by a chisel, and may indicate striking by a heavier object, e.g. another socketed axe. In addition, the piece has been jammed full of small objects and fragments. Only a few were visible, and x-rays of the object yielded no further information (Mason, pers. comm.). At the lower break, a flat object with looped attachment was visible, perhaps a button or a decorative fitting (c.f. Grays Thurrock I, 02/213). The following objects were visible in the mouth:- i) A thin curved fragment, possibly a fragmentary spearhead or gouge socket; ii) a lenticular-sectioned piece (?small knife blade), jammed between i) and the mouth of the axehead; iii) a fragment of sword hilt; iv) a fragment of square-sectioned object (?tang portion of tanged chisel); and v) a fragment with rectangular tang and spatulate blade. This latter item appears to be a chisel blade, though it is small in size and rather crescentic in shape along the cutting edge, which might indicate that it has seen much use. Its edge appears battered, and the piece has now been bent over slightly, and has a distorted profile as a result. The actual axehead also seems to have been in-filled with rough metal.

16/06

Description: Mouth and upper body of undecorated 'south-eastern' type socketed axe, with three collar mouldings present.

Dimensions: Length (maximum): 70m.

Patina: Some bronze showing, with shiny olive-green patches in places, and other areas which seem more rough in appearance. Details largely good.

Manufacture: The loop is malformed, having a waisted appearance. It appears to have sagged inwards slightly, giving a narrowed aperture. Its poor condition is probably due to a casting defect, though its narrow shape may be due to later hammering. The walls generally seem rather thin at the lower break, indicating core misalignment. The object has been well-finished, though. Over the body, the top seam has been hammered, but remains prominent. The lower seam is similar, but no traces remains over the loop.

Use: Impossible to determine.

Reduction: Hammering is evident on either face at the lower break, and the section has been distorted as a result. The interior has been stuffed full of fragmentary objects, including:- (*Visible at upper break*) i) a small piece of rough metal; ii) a mouth fragment of an object, probably a socketed axe, which is now in very poor condition, perhaps having been heated; iii) a small flat piece of bronze, apparently in good condition which may be the hilt fragment of a socketed knife; iv) a small flat piece of bronze, which broadens slightly in section at one end and which seems to be a mouth fragment from an unknown object; and (*Visible at the lower break*) a small flat piece of bronze, possibly a knife blade fragment.

16/07

Description: Mouth and upper body of 'south-eastern' socketed axe, with a single rib apparent within the socket.

Dimensions: Length (maximum): 75mm.

Patina: Thick dark green with some rough patches. Details largely good.

Manufacture: The mouth seems uneven, and the walls of the upper and lower surfaces seem rather thin, indicating core misalignment. There is in addition a peculiar stepped appearance to the section at the lower break, as if the metal failed to flow properly within the mould here. Stumps of the feeders are visible at the mouth, and there are some traces of the intervening seam surviving. Over the body, the upper seam is visible along its entire length, though the lower half towards the cutting edge has been flattened down more extensively. The lower seam is also visible over its extent, and, though prominent over the collar, has been flattened elsewhere. There are diagonal grinding marks apparent over the upper body on one face (illustrated), while the other face shows a series of grinding marks c.20mm from the break. The latter are confined to the interface between the face and the top surface.

Use: Impossible to determine.

Reduction: Substantial deformation and cracking on the upper surface seems to have resulted from a single blow made by a heavy, sharp-bladed object, perhaps an axe. There

are marked indentations on either face, and these may have been caused during the removal of the haft.

16/08

Description: Lower body and cutting edge from socketed axe, probably of 'south-eastern' type.

Dimensions: Length (maximum): 82mm. Cutting edge: 45mm.

Patina: Much of one face is the original bronze-colour, the other face being dark green. There are some rougher patches on both faces. Details variable.

Manufacture: On one side only faint traces of the seam remain, with grinding marks still evident following its removal. The other side is largely obscured by corrosion product, but some traces of the seam are apparent. There is evidence of fine hammering and also grinding marks on the faces and sides, but because the patina has not survived here, the latter must remain problematic. Similar marks are visible where the patina resumes, again associated with fresh metal, so these, too, must be viewed with caution.

Use: None of the original blade edge survives intact. Here, the metal seems blunt and is in poor condition, though subsequent build-up and loss of corrosion product may have exaggerated this situation.

Reduction: No evidence can be linked with this process.

16/09

Description: Lower body and cutting edge of socketed axe.

Dimensions: Length (maximum): 54mm. Cutting edge: 45mm.

Patina: Rough dark-green, details fair.

Manufacture: Only vestigial traces of the seam survive on either side, and slight evidence of core misalignment is apparent. The cutting edge has been widely expanded, and there are some horizontal grinding marks apparent over the blade.

Use: The cutting edge is very badly damaged, with large pieces broken from either corner. A small portion of the edge remains intact, and here it seems blunt, though reasonable.

Reduction: There is evidence of hammering on either face, and the section has become slightly distorted as a result, particularly where the wall is thinner.

16/10

Description: Lower body and cutting edge of socketed axe, with a distorted appearance to the profile which gives it a rather adze-like shape.

Dimensions: Length (maximum): 51mm. Cutting edge: 38mm.

Patina: Dark green.

Manufacture: Faint vestigial traces of a seam can be seen on one side, though it has been largely removed. On the other side, it has been obliterated completely. The cutting edge seems rather narrow, and some horizontal grinding marks are evident over the blade edge in places.

Use: The edge is intact, but is in a very poor condition, perhaps due to damage inflicted at a later stage in the object's use-cycle.

Reduction: The cutting edge has a burred and undulating appearance, and it looks as if this damage may have resulted from deliberate hammering. Perhaps such treatment also resulted in the adze-like profile. Hammer indents are evident on both sides at the break.

16/11

Description: Lower body and cutting edge of socketed axe.

Dimensions: Length (maximum): 49mm. Cutting edge: 42mm.

Patina: Mostly dense dark-green, with some rough patches in places.

Manufacture: The walls are of uneven thickness, indicating of core misalignment. The casting seam is still visible along one side, but has been obliterated on the other. The blade is well-expanded.

Use: None of the original cutting edge remains intact, and large pieces are now missing from either corner.

Reduction: Both faces have been crushed inwards at the break, causing distortion and cracking of the metal just above the solid-sectioned portion of the blade. The base of the socket has been infilled with a white metallic substance (?lead - c.f. 16/14).

16/12

Description: Lower body and blade of socketed axe.

Dimensions: Length (maximum): 54mm. Cutting edge: 41mm.

Patina: Thick green, details obscured in places.

Manufacture: Faint vestigial traces of the casting seams survive on either side, though these appear to have been well trimmed and flattened. The cutting edge has a rather narrow appearance.

Use: This is difficult to determine, as the cutting edge has not survived. There are large pieces missing from either corner, and the blade is chipped along its length.

Reduction: There is no evidence relating to this process.

16/13

Description: Lower body and blade of socketed axe, with much of one face now missing above the point where the solid-sectioned blade adjoins the socket.

Dimensions: Length (maximum): 60mm. Cutting edge: 37mm.

Patina: Some bronze showing, but much has been obscured by a rough coating of dark green patina. Details obscured on one face.

Manufacture: The casting seam has been virtually obliterated over one side, but remains visible as a vestigial trace on the other. The cutting edge is narrow in appearance.

Use: There are no indications of resharpening, though the edge must have seen some use prior to reduction, for it is blunt along its length and there is a large notch now missing from its extent.

Reduction: There is no evidence relating to this process.

16/14

Description: Blade fragment of socketed axe - with only one face surviving to any extent, the other consisting of little more than the cutting edge. The base of the socket has been filled with another metallic substance, analysed and identified as a lead alloy (containing a minor proportion of tin).

Dimensions: Length (maximum): 40mm. Cutting edge: 47mm.

Patina: Dark green, details good.

Manufacture: The surviving wall seems thin. Documentation accompanying the hoard included a note by Needham which suggests that this was deliberate, the walls having been created thin for the purpose of including of lead within the socket. This would make the blade heavier, and therefore more effective as a cutting implement. However, I would argue that it seems equally likely that the piece was infilled as part of a damage limitation exercise, made necessary because the casting was weak as a result of core misalignment. Grinding marks are apparent all over the surviving face, and the cutting edge seems well-expanded.

Use: The edge seems to be in good condition, with only a few chips missing along its length. It is likely that the object broke during use.

Reduction: There is no evidence relating to this process.

16/15

Description: Cutting edge from socketed axe.

Dimensions: Length (maximum): 26mm. Cutting edge: 39mm.

Patina: Some bronze is showing, but patches of dark olive green are also present. Details largely good, though some areas are obscured.

Manufacture: Faint traces of the casting seams are apparent on both sides. There are diagonal grinding marks over the cutting edge in places, and a faint bevel can be glimpsed, running along the blade edge.

Use: The blade is unevenly worn, and one corner has broken away. The edge, where it remains intact, appears chipped and blunt along its length.

Reduction: There is no evidence relating to this process.

16/16

Description: Short mouth fragment of socketed axe, including loop, probably of 'south-eastern' type.

Dimensions: Length (maximum): 43mm. Width: 24mm.

Patina: Thick, rather rough dark green. Details quite poor.

Manufacture: The wall seems slightly thin, suggesting that the core was misaligned. The seams have been poorly finished: though they have been trimmed and flattened over the loop, they remain prominent and rounded over the collar and at the junction between the loop and the body.

Use: Impossible to determine.

Reduction: There is no evidence relating to this process.

16/17

Description: Short mouth fragment of socketed axe, possibly of 'south-eastern' type, with one internal rib present.

Dimensions: Length (maximum): 20mm.

Patina: Dark green, somewhat rough, but details are reasonable.

Manufacture: The mouth seems uneven, and the wall is rather thin in section, suggesting core misalignment. No other evidence relating to this process can be seen.

Use: Impossible to determine.

Reduction: There is no evidence relating to this process.

16/18

Description: Short mouth fragment of socketed axe, including loop. It probably came from a 'south-eastern' type axehead, though one of the diagnostic collar mouldings appears to have been obliterated as a result of hammering.

Dimensions: Length (maximum): 29mm.

Patina: Dense dark green/olive. Details reasonable.

Manufacture: The seam remains prominent over the collar mouldings, but has been obliterated over the loop.

Use: Impossible to determine.

Reduction: A probable hammer indent can be seen near the break, and this was probably inflicted during the fragmentation process.

16/19

Description: Tiny fragment from mouth of socketed axe, with two collar mouldings visible.

Dimensions: Length (maximum): 21mm.

Patina: Pale grey-green. Details poor.

Manufacture: The mouth appears uneven, but there is no other evidence relating to this phase.

Use: Impossible to determine.

Reduction: There is no evidence relating to this process.

16/20

Description: Small mouth fragment of socketed axe, with the vestigial trace of an internal rib apparent.

Dimensions: Length (maximum): 26mm. Width: 27mm.

Patina: Rough grey-green, details poor.

Manufacture: The mouth seems rather rough, with traces of the seam surviving here.

Use: Impossible to determine.

Reduction: There is no evidence relating to this process.

16/21

Description: Fragment of bladed object. Only one edge is bevelled and sharp, and the object appears too straight to be a sickle. It therefore seems likely that it is a blade fragment from a single-edged knife.

Dimensions: Length (maximum): 49mm.

Patina: Some bronze showing, with dark green patination in some places. Details locally excellent.

Manufacture: Extensive vertical grinding marks are visible down the length of the blade, and a bevel runs along the cutting edge. A casting seam remains over the blunt edge, and it appears to be very thick and blunt, having apparently been retained as a decorative element in the piece.

Use: The edge is basically good, though it is chipped in places along its length.

Reduction: There is no evidence pertaining to this process.

16/22

Description: Shoulders and upper blade of 'Ewart Park type' sword. Four rivet holes survive, with the vestigial remains of another apparent at the upper break. Slight ricasso notches are evident, and a faint groove marks the original line of the organic hilt-plate on the side illustrated.

Dimensions: Length (maximum): 104mm.

Patina: Mainly thick dark green, though some corrosion loss has revealed a large patch of fresh metal on one side, and all details have gone here. Elsewhere, they are excellent.

Manufacture: No traces of any casting seams survive, and there are grinding marks apparent in numerous places. Especially noticeable are a number of vertical grinding marks running down the blade, which bears a fine bevel along both cutting edges.

Use: The cutting edges no longer survive on either side, though damage appears worse on one blade edge than it does on the other. It is possible that one of the rivet holes at the shoulder may have given way as a result of strain caused by repeated use. A number of scratches run across both faces, and while some may have been due to use-related damage, others could not have been caused in this way as they lie in the area where the hilt-plate would once have been.

Reduction: It is possible that the marks mentioned above were caused by a chisel during the removal of the hilt-plate. The blade also showed hammer indents near the break on both sides.

16/23

Description: Fragment of unknown sword type, comprising shoulders and very top of blade, with a probable rivet hole surviving in vestigial form.

Dimensions: Length (maximum): 38mm.

Patina: Thick dark green, details poor.

Manufacture: No evidence relating to this process can be seen.

Use: Impossible to determine, as none of the blade survives.

Reduction: There is no evidence relating to this process.

16/24

Description: Substantial blade fragment of leaf-shaped sword.

Dimensions: Length (maximum): 137mm.

Patina: Thick dark green, details good.

Manufacture: The blade edges are finely bevelled, with vertical grinding marks evident running down bevels and blade.

Use: The blade edges are in poor condition on both sides. They are completely absent in one location, and are battered and notched elsewhere. Numerous scratches are evident on the blade, and these apparently originated in antiquity.

Reduction: There is a marked 'S'-shaped bend to the profile, but there are no visible hammer marks associated with either break.

16/25

Description: Blade fragment of leaf-shaped sword.

Dimensions: Length (maximum): 45mm.

Patina: Thick dark green, details variable.

Manufacture: The blade edges are finely bevelled, with some vertical grinding marks running down blade and bevels.

Use: Both cutting edges appear to be in poor condition. One side is badly chipped along its entire length, while on the other some of the original edge remains, though some stretches of chipping and burring are apparent.

Reduction: Marked distortion of the profile is apparent, though no associated hammering is evident. The lower break (as illustrated) shows cracking of the metal, damage which must have resulted from the strain placed on the metal during this process.

16/26

Description: Blade fragment from leaf-shaped sword.

Dimensions: Length (maximum): 45mm.

Manufacture: The blade edges are finely bevelled, and vertical grinding marks run down the length of the blade in places.

Use: The edges are chipped and notched over much of their length.

Reduction: The lower break is associated with a single hammer indent (illustrated) and there is a slight 'S'-shaped profile to the blade.

16/27

Description: Blade fragment from leaf-shaped sword, with a possible row of pointille decoration running up the bevel on one side (illustrated). This must remain tenuous, as this apparent decoration is only visible along one bevel, and examination under a microscope should be considered desirable in confirming its presence.

Dimensions: Length (maximum): 23mm.

Patina: Some bronze showing, the rest of the piece being dark green. Details reasonable.

Manufacture: Some grinding marks are apparent on blade and bevels.

Use: The edges are badly chipped, with one side displaying a number of marked notches.

Reduction: There is a faint bend to the profile, and evidence of rough hammering on the midrib.

16/28

Description: Blade fragment of leaf-shaped sword. A double set of incised lines define the midrib, and the bevels along the blade edges are also highlighted by incised lines. Possibly of Thames or Gundlingen type?

Dimensions: Length (maximum): 42mm.

Patina: Some bronze shows in places, and there are rough patches of bright green encrustation apparent in places.

Manufacture: The blade looks finely hammered and polished, but no evidence of any grinding marks can be seen.

Use: One edge remains sharp and fine where corrosion does not obscure it. The other has very little of the original edge remaining, and is notched and chipped along its length.

Reduction: A very faint bow to the profile is apparent, but there is no evidence of any associated hammering.

16/29

Description: Blade fragment of a sword which has the defined midrib of a 'Carp's Tongue' sword, but which appears to be leaf-shaped.

Dimensions: Length (maximum): 58mm.

Patina: Some bronze showing, with some dull green patches, and some mottled reddish-brown/green encrustation evident.

Manufacture: Faint bevels run down the blade edges, and some vertical grinding marks are apparent, running down blade and bevels.

Use: One side is chipped and notched over its length, with none of the original cutting edge remaining intact. The other side is better preserved, with some of its extent remaining fine and sharp. Here, one substantial notch is evident, with another similar example present beneath this.

Reduction: There is a marked bend to the profile, and a number of hammer indents can be identified near the upper break on one face (illustrated). One marked hammer indent is apparent on the lower break on the other face (not illustrated).

16/30

Description: Probable sword pommel fitting (c.f. All Hallows 13/23), with a single rivet hole surviving in the tang.

Dimensions: Length (maximum): 28mm.

Patina: Shiny grey-green, details poor.

Manufacture: The piece appears well-finished, with no seams surviving.

Use: Impossible to determine.

Reduction: Deliberate breakage can be suggested. The piece is now incomplete, and on one face (illustrated) there are hammer indents associated with the break.

16/31

Description: Incomplete socketed spearhead, with one rivet hole surviving in fragmentary form.

Dimensions: Length (maximum): 105mm.

Patina: Thick dark-green. Some encrustation apparent, with some bronze showing through in places. Details reasonable.

Manufacture: All the casting seams have been obliterated. There is a marked bevel to the edge of the blade, and vertical grinding marks run down blade and bevels. There are a series of striations apparent on the centre of the midrib and a marked score running down the length of the midrib (illustrated). These marks cannot be accounted for.

Use: The edges appear very battered and the tip is now missing. The break to the socket may be use-related.

Reduction: The socket could have been broken through hammering, though no individual hammer indents can be seen. A number of pieces of metal have been wedged inside the base of the midrib - two are fragments of rough metal, and the third has a distinctly lenticular appearance to the section, though the surface appears very poor. There is a lump of rough or ingot metal adhering to this. *Note: These insertions follow the shape of the original socket, which might suggest that breakage took place following this insertion. Object No. 16/34 is adjoining.*

16/32

Description: Lower blade fragment of socketed spearhead.

Dimensions: Length (maximum): 35mm.

Patina: Thick mid-green, with some rougher patches. Details reasonable.

Manufacture: A bevel runs along the surviving cutting edge, and some vertical grinding marks are visible at the interface between midrib and blade. There is evidence of core misalignment, the section of the wall appearing rather thin here.

Use: The edge now has a very battered appearance. It is chipped over its length, but its poor condition may have resulted at least partly from later loss of corrosion products.

Reduction: Socket and blade have been separated, with evidence of hammering apparent at the lower break. The upper break also shows a number of hammer indents, associated with marked crushing of the section.

16/33

Description: Fragment of spearhead socket. It is possible that it once adjoined 16/31, though this seems unlikely, as the sections do not quite match between the pieces.

Dimensions: Length (maximum): 27mm.

Patina: Dark green, flaking away in places.

Manufacture: Fine hammering is apparent over the surface, undoubtedly associated with finishing and the removal of the seam.

Use: Impossible to determine, as the cutting edges do not survive.

Reduction: The section shows evidence of distortion, but there are no marked hammer indents present in association.

16/34

Description: Fragment of spearhead socket, possibly adjoining 16/32, though the patina is dissimilar on both pieces.

Dimensions: Length (maximum): 23mm.

Patina: Dark green, but brighter than that seen in 16/32.

Manufacture: There is no evidence relating to this process.

Use: Impossible to determine, as the cutting edge does not survive.

Reduction: There is no evidence relating to this process.

16/35

Description: Circular-sectioned bronze ring, apparently solid-cast.

Dimensions: Diameter: 34mm.

Patina: Dark green.

Manufacture: The object is unfinished, with casting seams apparent around the extent and interior surfaces of the piece, and with stumps of the feeders surviving.

Use: Though final finishing did not occur, the ring may have been used, as some of the interior appears a little shiny, with the seams not so evident here.

Reduction: There is no evidence relating to this process.

16/36

Description: Bronze fitting, possibly a button, though no means of attachment is visible. There are two stumps visible on the rear of the piece: perhaps this was a failed casting, and the object was originally intended to possess a loop by which it could be affixed to another item. A series of concentric circular ribs and furrows radiate from the central point, and these were part of the casting, as opposed to having been hammered out at a later point (c.f. the embossed fittings in the Minnis Bay hoard, 19/67-72).

Dimensions: Diameter: 23mm.

Patina: Rough dark green, details poor.

Manufacture: See **Description** above. No indications of the casting seam can be seen.

Use: There is no evidence relating to this process.

Reduction: There is no evidence relating to this process.

16/37

Description: A peculiar object of circular section, narrowing at either end and swelling towards the centre. It has been broken at either end. This piece has been identified as a bead (though there are no perforations evident which might indicate this, thus suggesting the presence of a failed casting) or the terminal of a bracelet, though perhaps the shank of a pin might be an equally appropriate suggestion.

Dimensions: Length (maximum): 25mm.

Patina: Dense grey-green, details reasonable.

Manufacture: No traces of any casting seams are evident. Slight pitting in one face seems unusually regular in shape, but it cannot be one side of a perforation as no similar mark matches it on the other side. It must therefore be a minor casting defect.

Use: Impossible to determine.

Reduction: There is no evidence pertaining to this process.

16/38

Description: Tiny fragment of bronze, broken from another object. It is stored with spearhead 16/32, and the two spearhead socket fragments, but it cannot be assumed that all three fragments were once part of the same object.

Manufacture: There are faint traces of a casting seam evident upon the fragment.

Use: Impossible to determine.

Reduction: Impossible to determine.

16/39

Description: Unusual fragment, originally of circular shape, and bordered by a thickened rim. It is described as 'plate scrap' in the National Bronze Index, though no similar examples like this have been recovered amongst the contents of the 'Carp's Tongue' hoards in this area.

Dimensions: Length (maximum): 45mm.

Patina: Rough mid-green, details obscured.

Manufacture: Uncertain. No indications of any casting seams are evident, with all surfaces appearing smooth.

Use: Not applicable.

Reduction: The object shows a number of rough hammer indents over one surface, and these probably result from fragmentation.

16/40

Description: Casting jet from unknown object, with a circular reservoir and two feeder stumps.

Dimensions: Length: 19mm.

16/41

Description: Large piece from edge of copper ingot, with numerous voids present in the interior.

Dimensions: Length: 92mm. Width: 73mm. Thickness: 27mm.

Observations: The edge seems flattened and a little burred, suggesting possible re-use as a hammer.

16/42

Description: Large piece of copper ingot, with some voids present in the interior.

Dimensions: Length: 68mm. Width: 75mm. Thickness: 26mm.

Observations: There are a number of potential hammer indents on both surfaces, and some possible chisel marks can be seen close to the break.

16/43

Description: Fragment of copper ingot, with numerous voids evident in the piece.

Dimensions: Length: 33mm. Width: 32mm. Thickness: 15mm.

16/44

Description: Fragment from exterior of copper ingot, with numerous voids present in the piece.

Dimensions: Length: 33mm. Width: 32mm. Thickness: 15mm.

16/45

Description: Fragment from interior of copper ingot.

Dimensions: Length: 30mm. Width: 18mm. Thickness: 20mm.

16/46

Description: Piece from exterior of thick copper ingot, with numerous voids evident in the cross-section.

Dimensions: Length: 68mm. Width: 55mm. Thickness: 27mm.

Observations: There are some possible striations evident on one face (not illustrated), and some lumps of spilled metal adhering on the other (illustrated).

16/47

Description: Piece from edge of copper ingot, surface pitted and rough.

Dimensions: Length: 65mm. Width: 47mm. Thickness: 26mm.

16/48

Description: Interior fragment of copper ingot.

Dimensions: Length: 46mm. Width: 40mm. Thickness: 34mm.

Observations: There are possible chisel marks on the flatter surface (not illustrated).

16/49

Description: Piece from edge of thick copper ingot, with numerous voids apparent.

Dimensions: Length: 41mm. Width: 61mm. Thickness: 26mm.

16/50

Description: Edge fragment of copper ingot, with large voids present in the interior.

Dimensions: Length: 33mm. Width: 31mm. Thickness: 18mm.

16/51

Description: Edge fragment of copper ingot, with a large number of voids apparent.

Dimensions: Length: 25mm. Width: 35mm. Thickness: 17mm.

16/52

Description: Edge fragment of copper ingot, with a large number of voids present.

Dimensions: Length: 25mm. Width: 35mm. Thickness: 17mm.

16/53

Description: Fragment from interior of thin copper ingot, with a large number of voids present.

Dimensions: Length: 29mm. Width: 20mm. Thickness: 13mm.

Observations: Possible chisel marks evident in places.

16/54

Description: Edge fragment from thick copper ingot.

Dimensions: Length: 46mm. Width: 40mm. Thickness: 34mm.

Observations: Possible chisel marks on the flatter surface.

16/55

Description: Edge fragment of copper ingot, with large voids present in the interior.

Dimensions: Length: 33mm. Width: 31mm. Thickness: 18mm.

16/56

Description: Fragment from edge of thick copper ingot.

Dimensions: Length: 41mm. Width: 34mm. Thickness: 24mm.

16/57

Description: Fragment from edge of copper ingot.

Dimensions: Length: 42mm. Width: 28mm. Thickness: 13mm.

16/58

Description: Edge fragment of copper ingot, large number of voids present.

Dimensions: Length: 23mm. Width: 35mm. Thickness: 17mm.

16/59

Description: Small fragment from edge of copper ingot.

Dimensions: Length: 28mm. Width: 22mm. Thickness: 13mm

16/60

Description: Small fragment from edge of copper ingot, very thin in section.

Dimensions: Length: 27mm. Width: 26mm. Thickness: 9mm.

16/61

Description: Tiny fragment of copper ingot.

Dimensions: Length: 26mm. Width: 16mm. Thickness: 10mm.

16/62

Description: Fragment of copper ingot, voids apparent in the interior.

Dimensions: Length: 29mm. Width: 29mm. Thickness: 18mm.

16/63

Description: Edge fragment of copper ingot.

Dimensions: Length: 29mm. Width: 24mm. Thickness: 17mm.

16/64

Description: Fragment of copper ingot.

Dimensions: Length: 26mm. Width: 18mm. Thickness: 9mm.

16/65

Description: Tiny fragment of copper ingot.

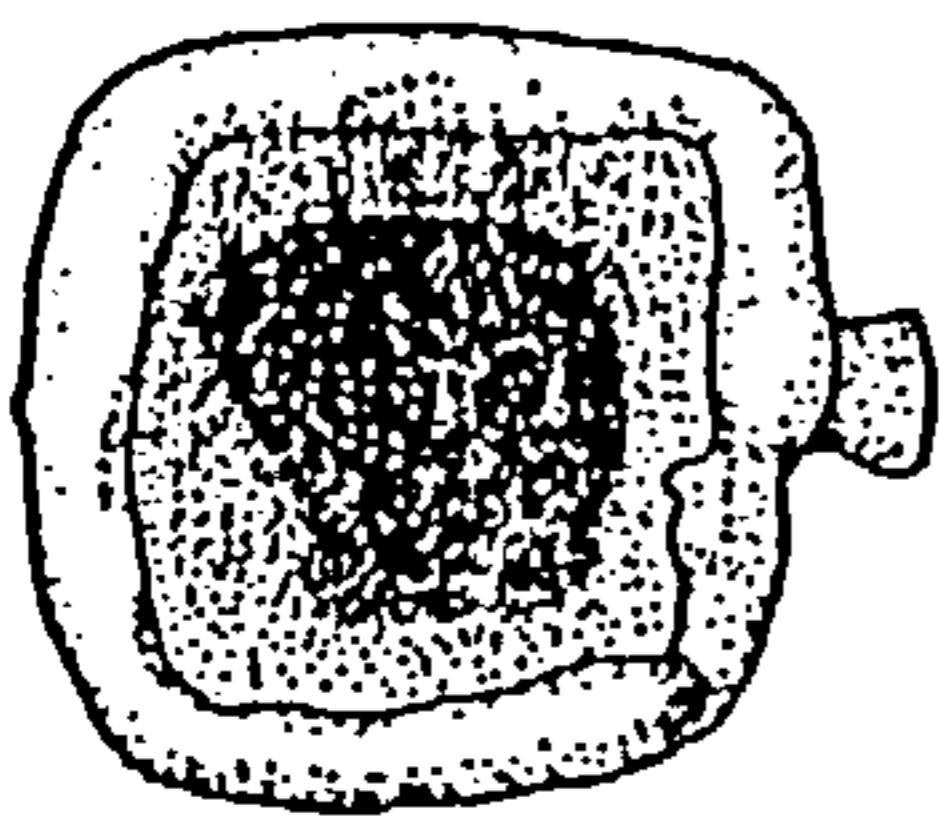
Dimensions: Length: 26mm. Width: 21mm. Thickness: 13mm.

16/66

Description: Fragment from interior of copper ingot.

Dimensions: Length: 18mm. Width: 16mm. Thickness: 20mm.

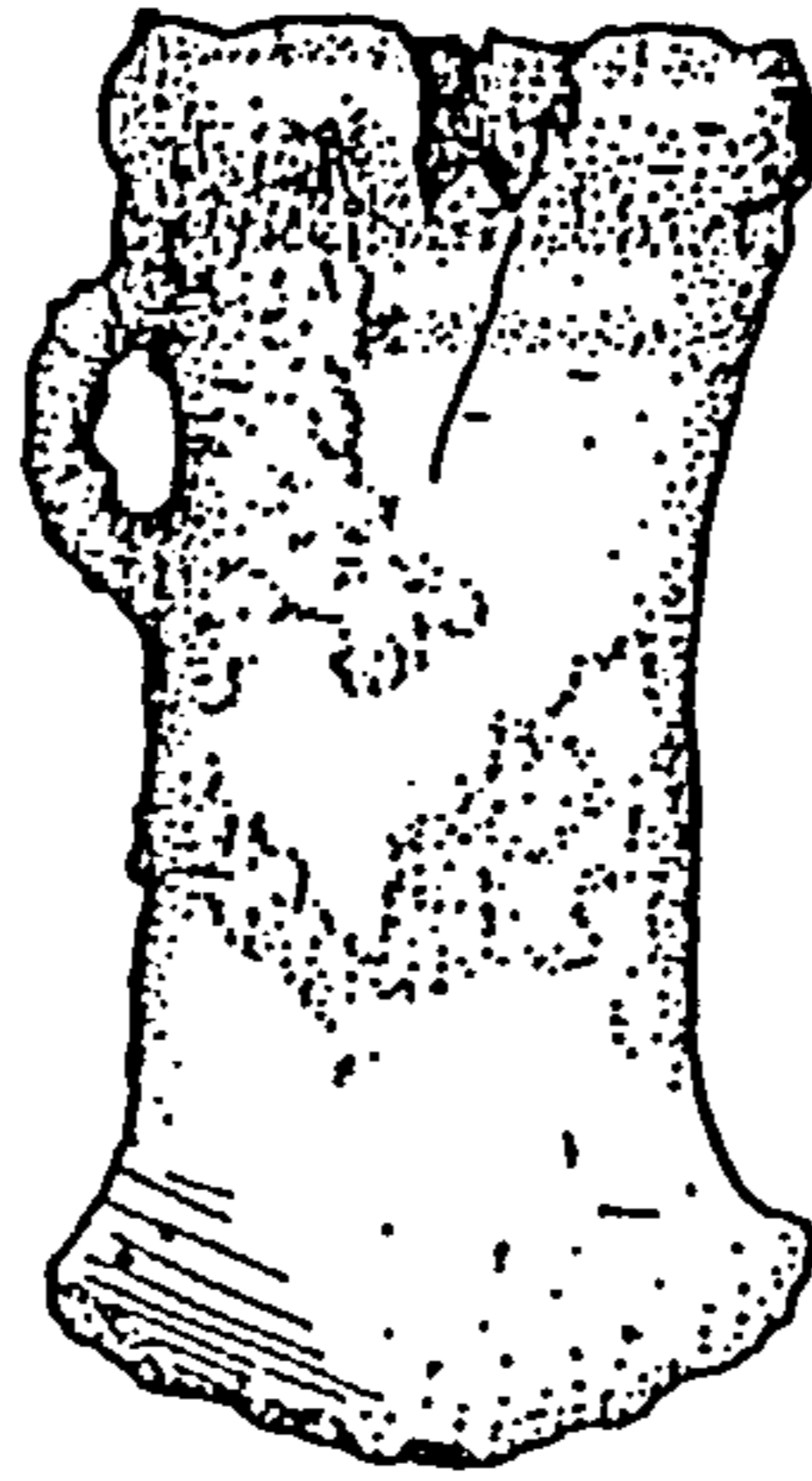
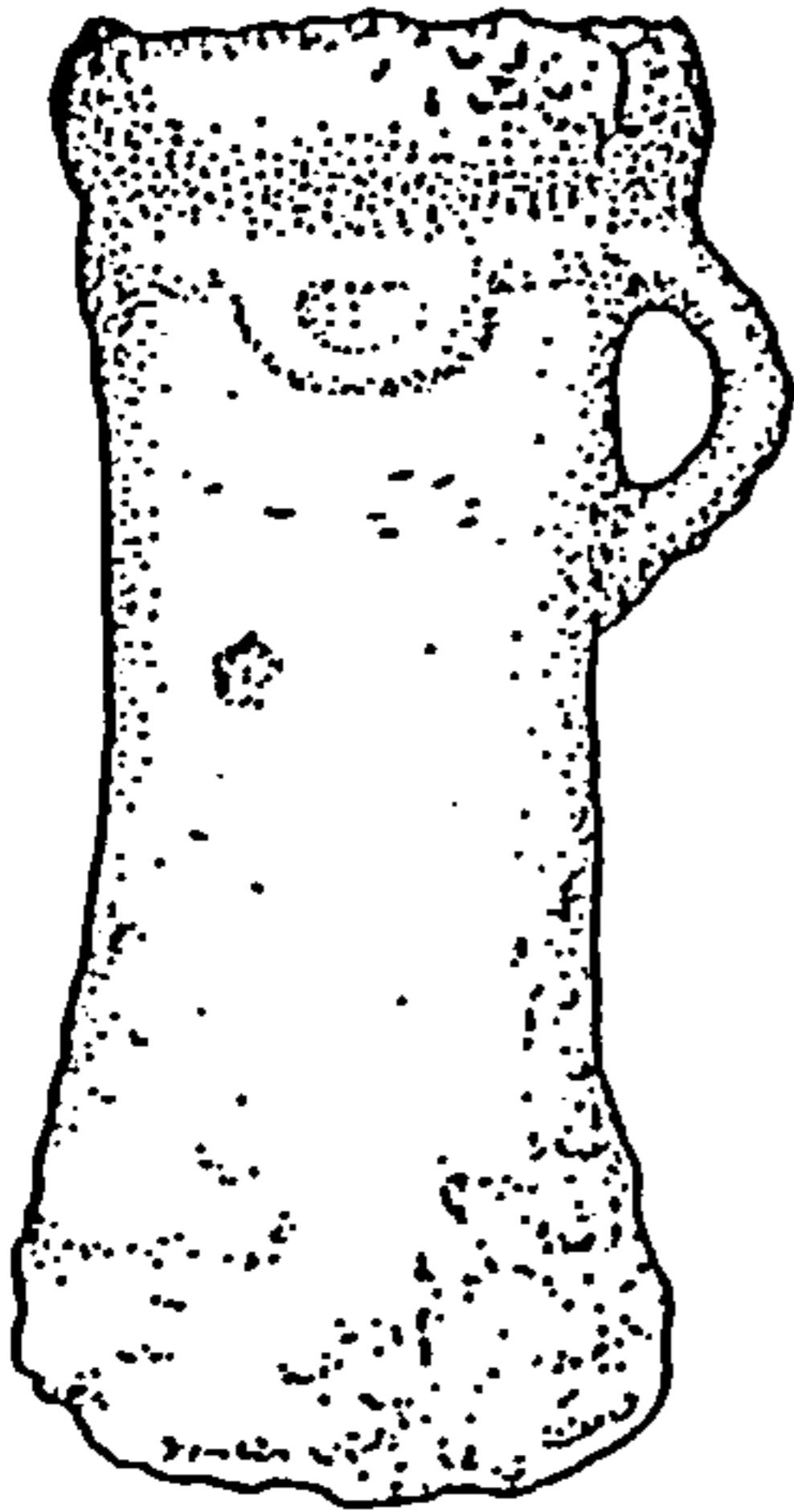
16/01



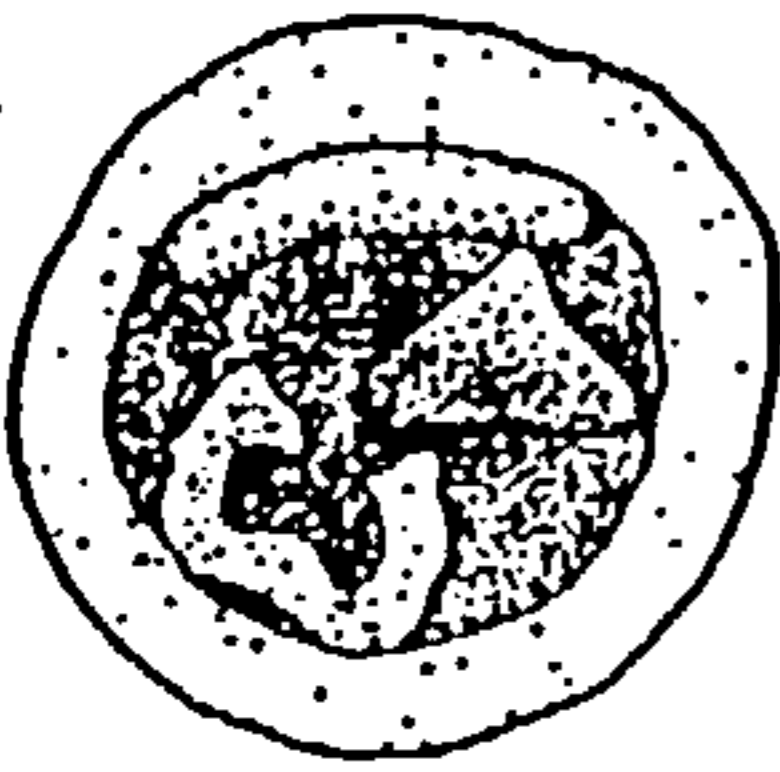
16/02



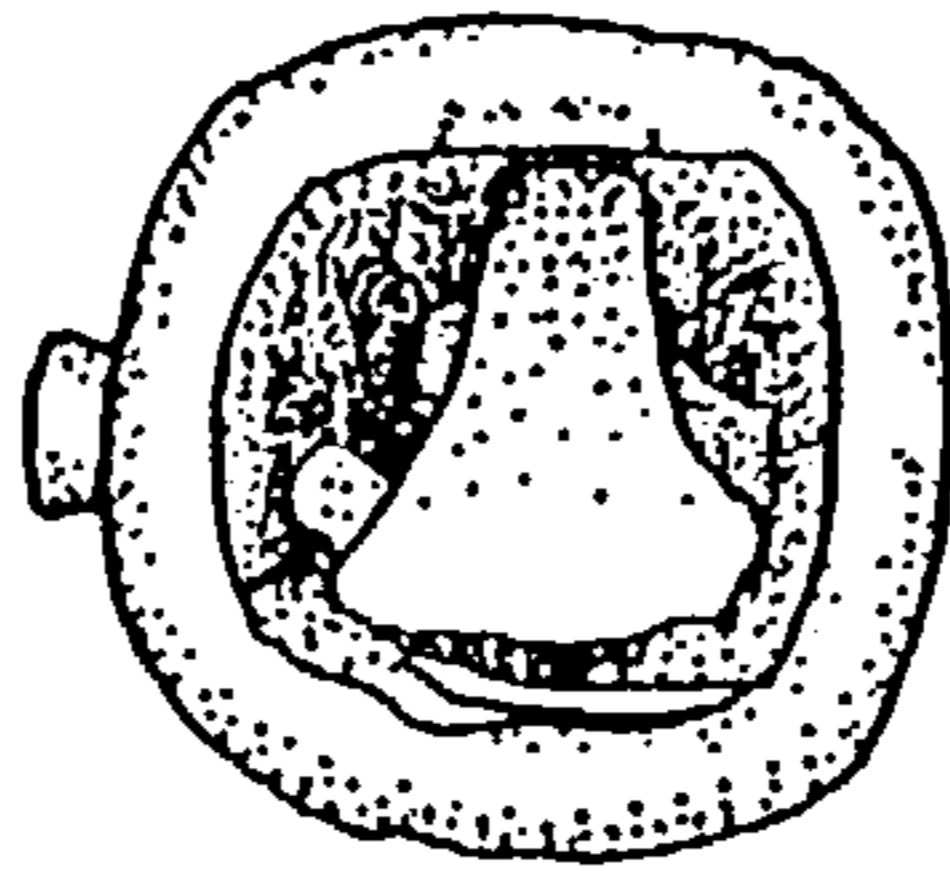
16/03



16/04



16/05



0 2cm

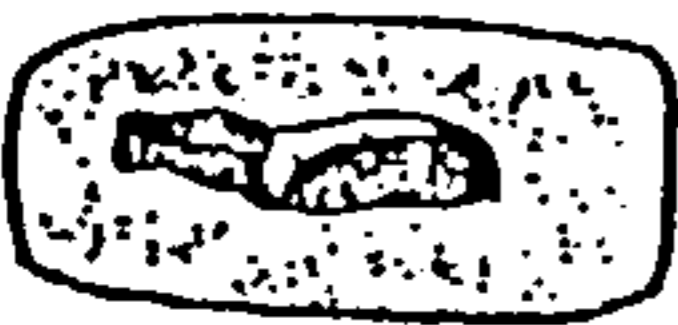
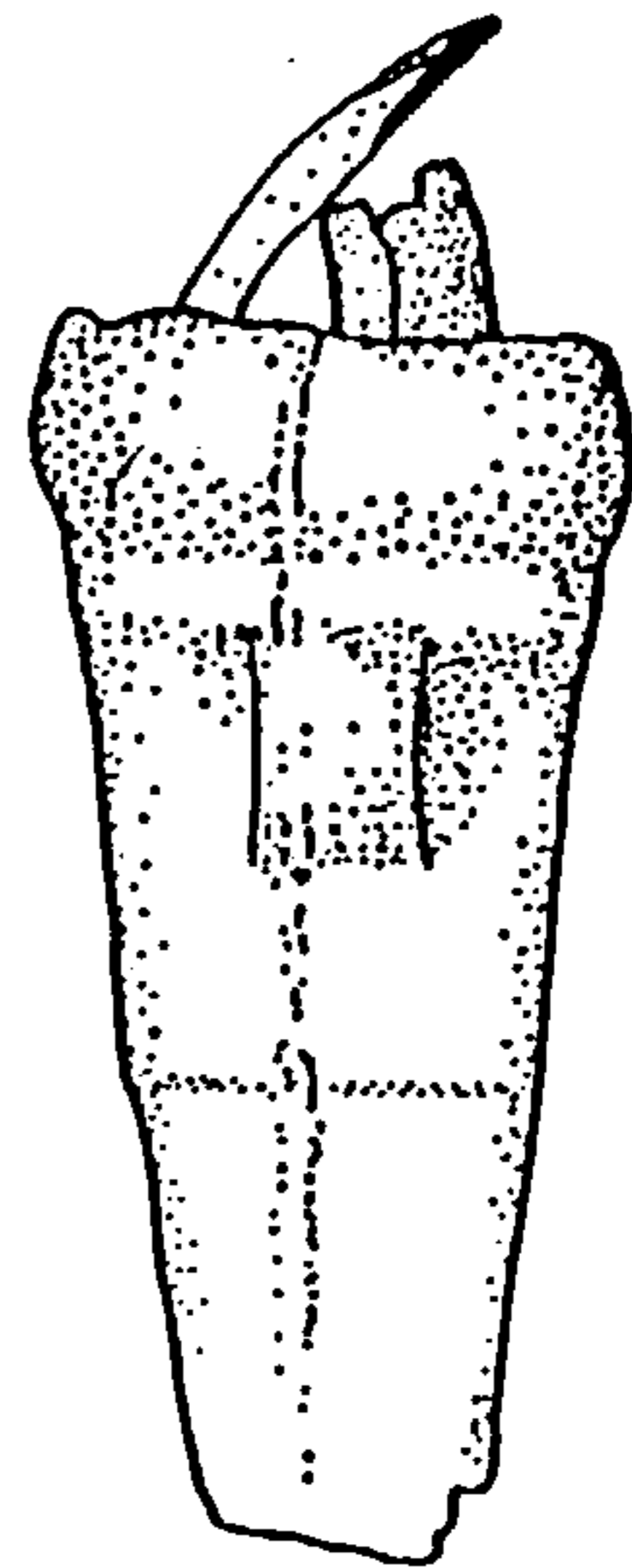
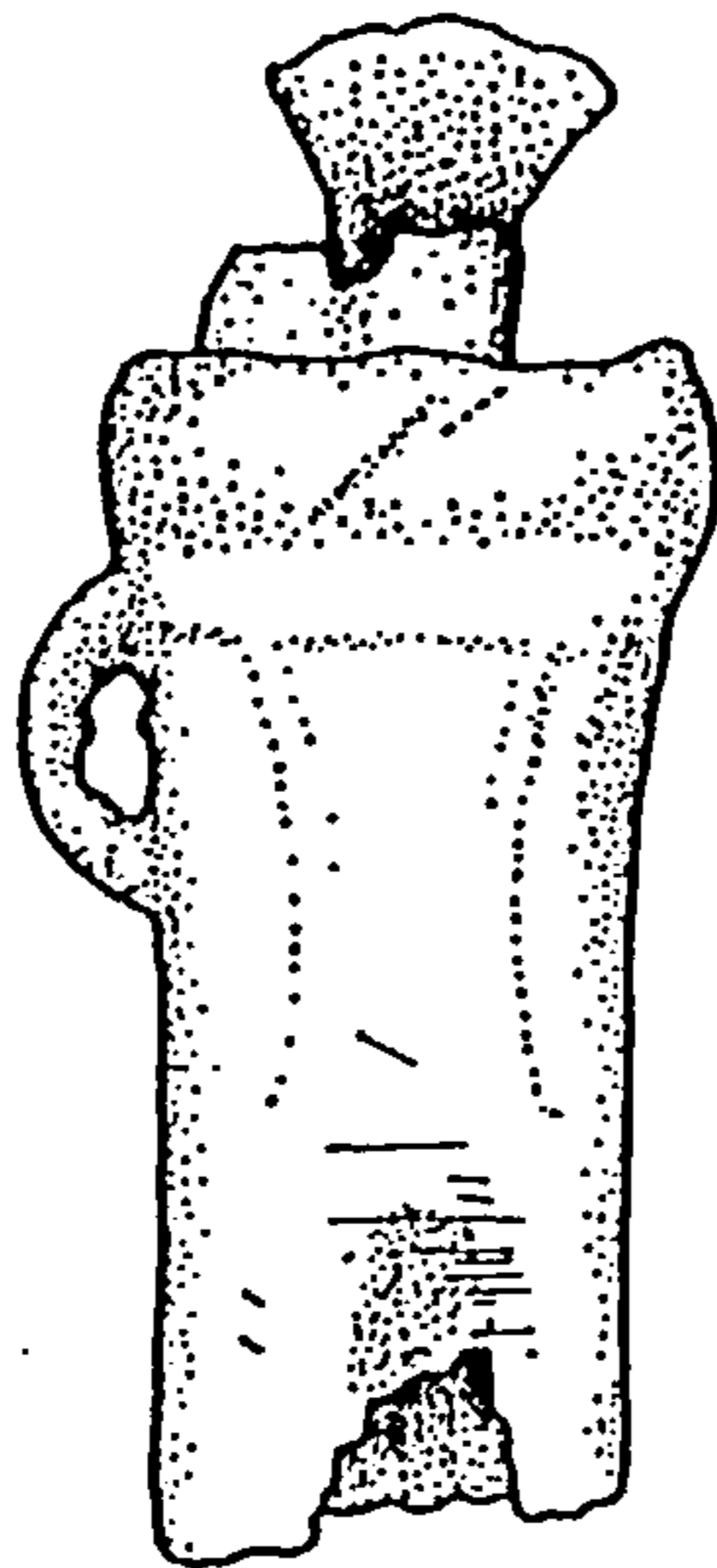
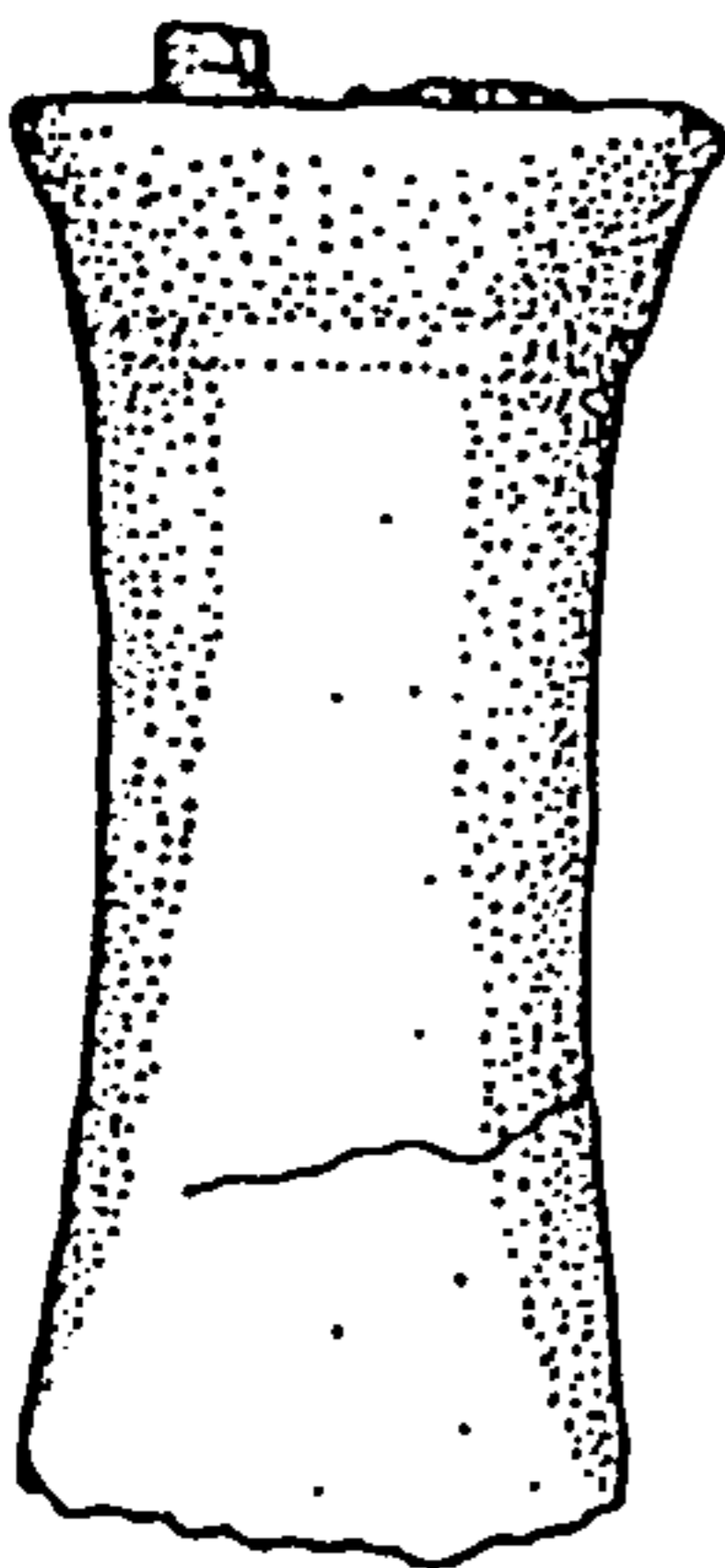
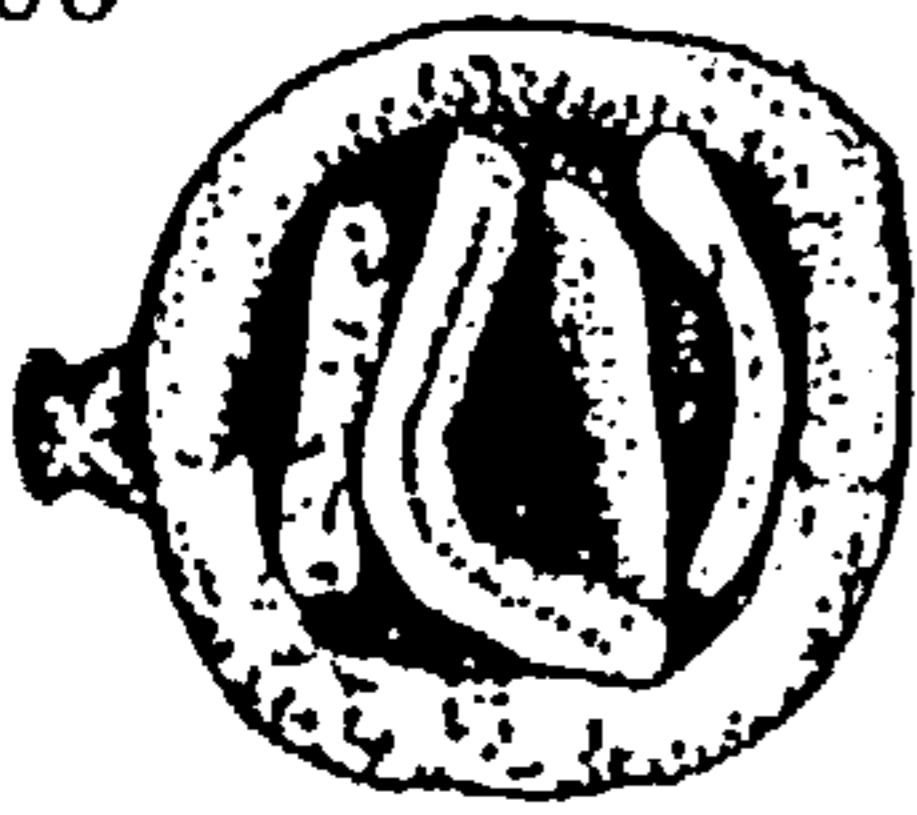
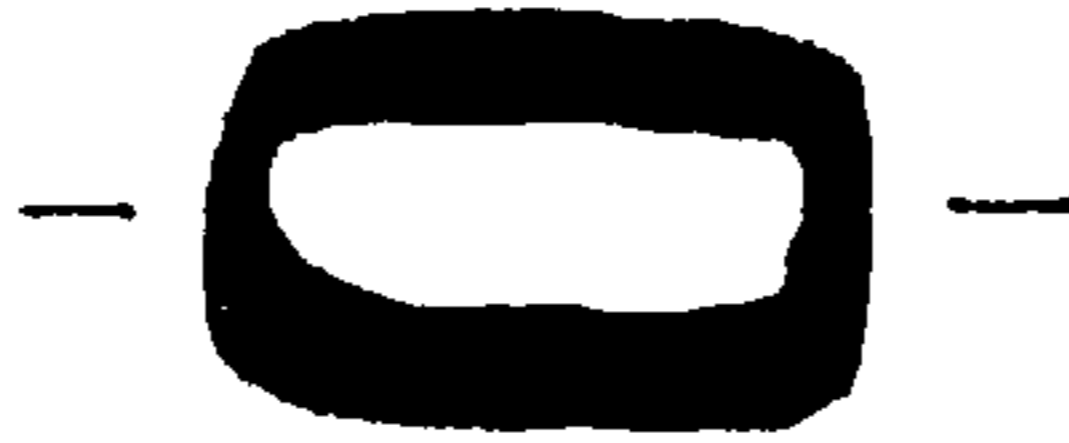
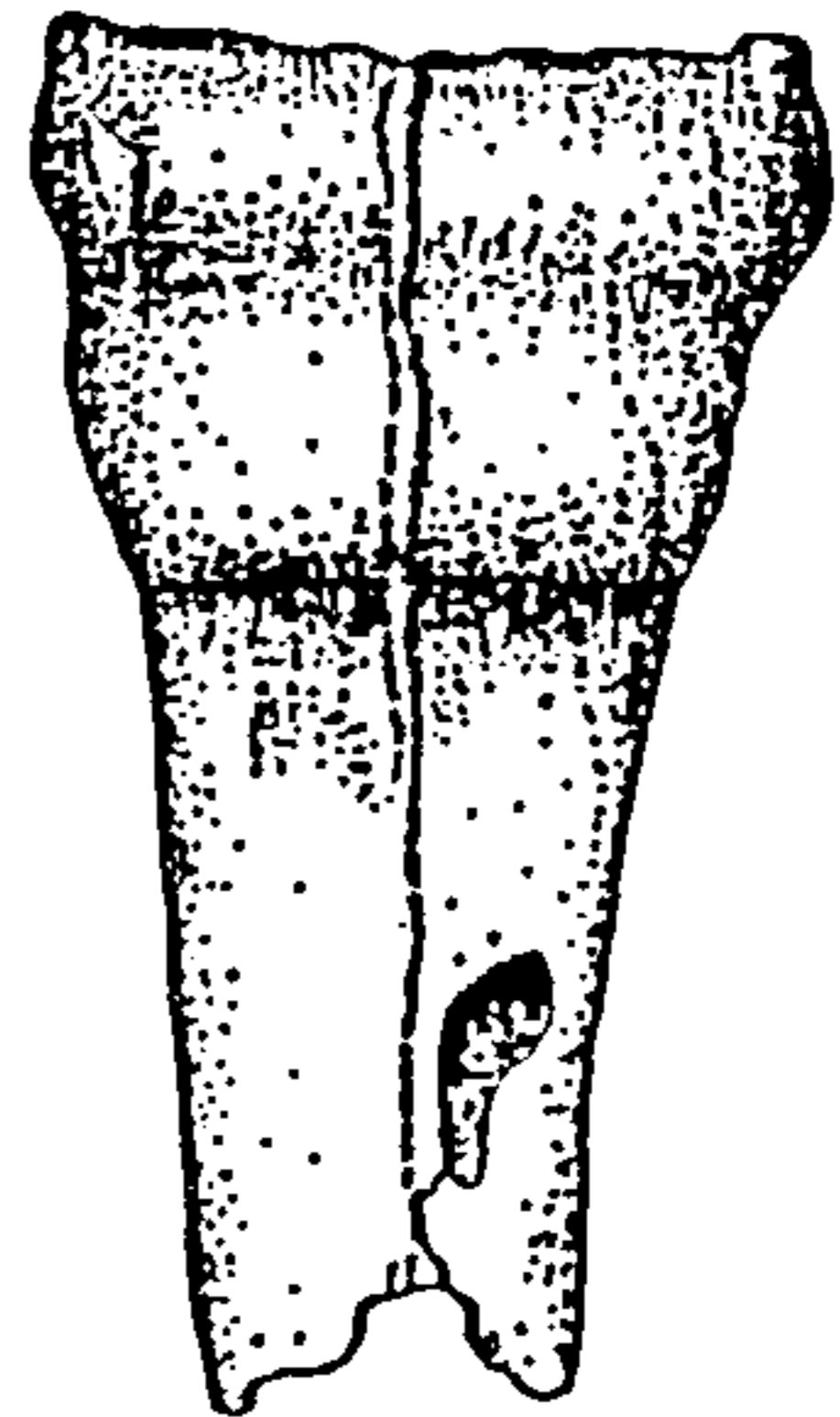
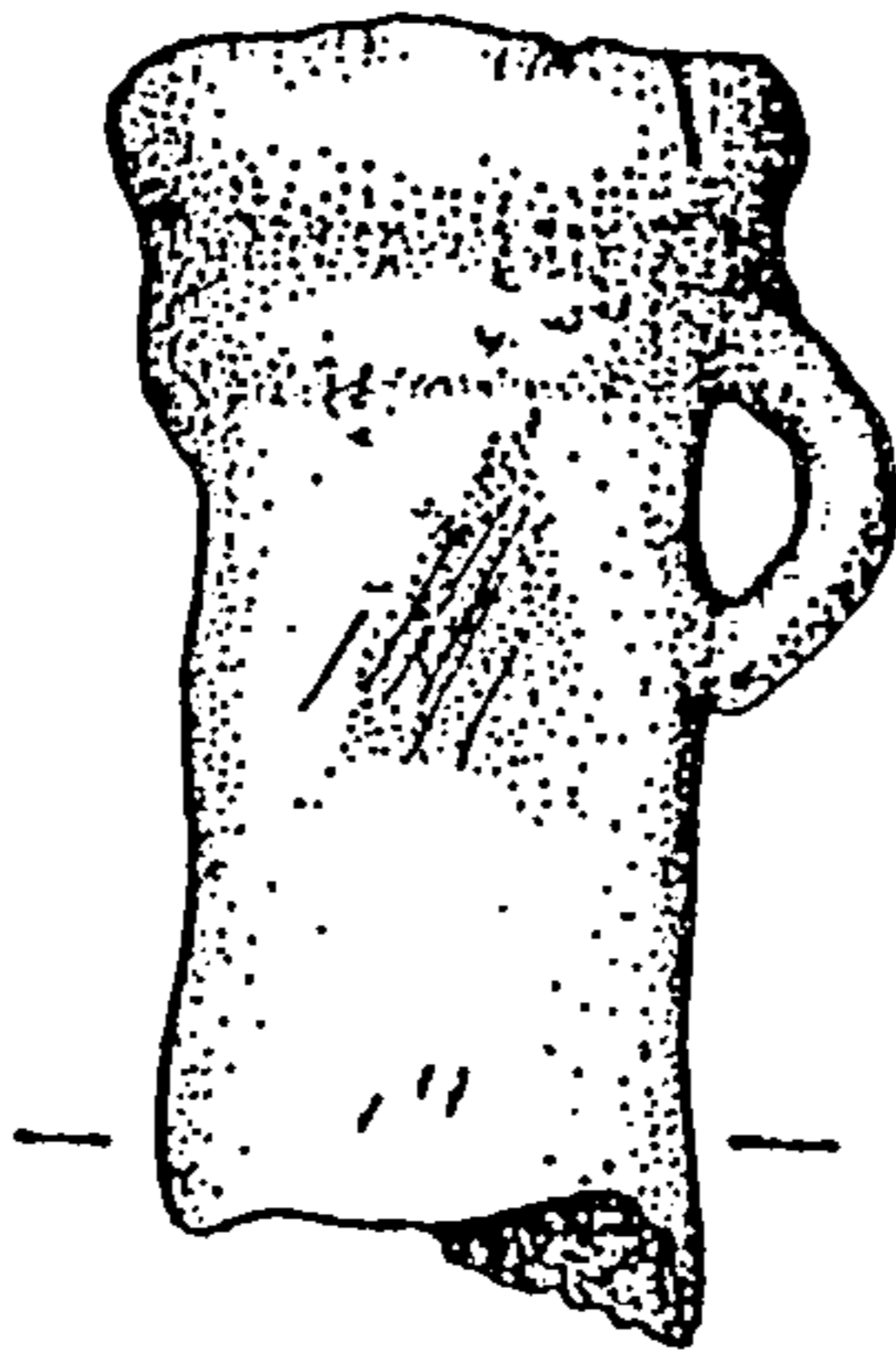
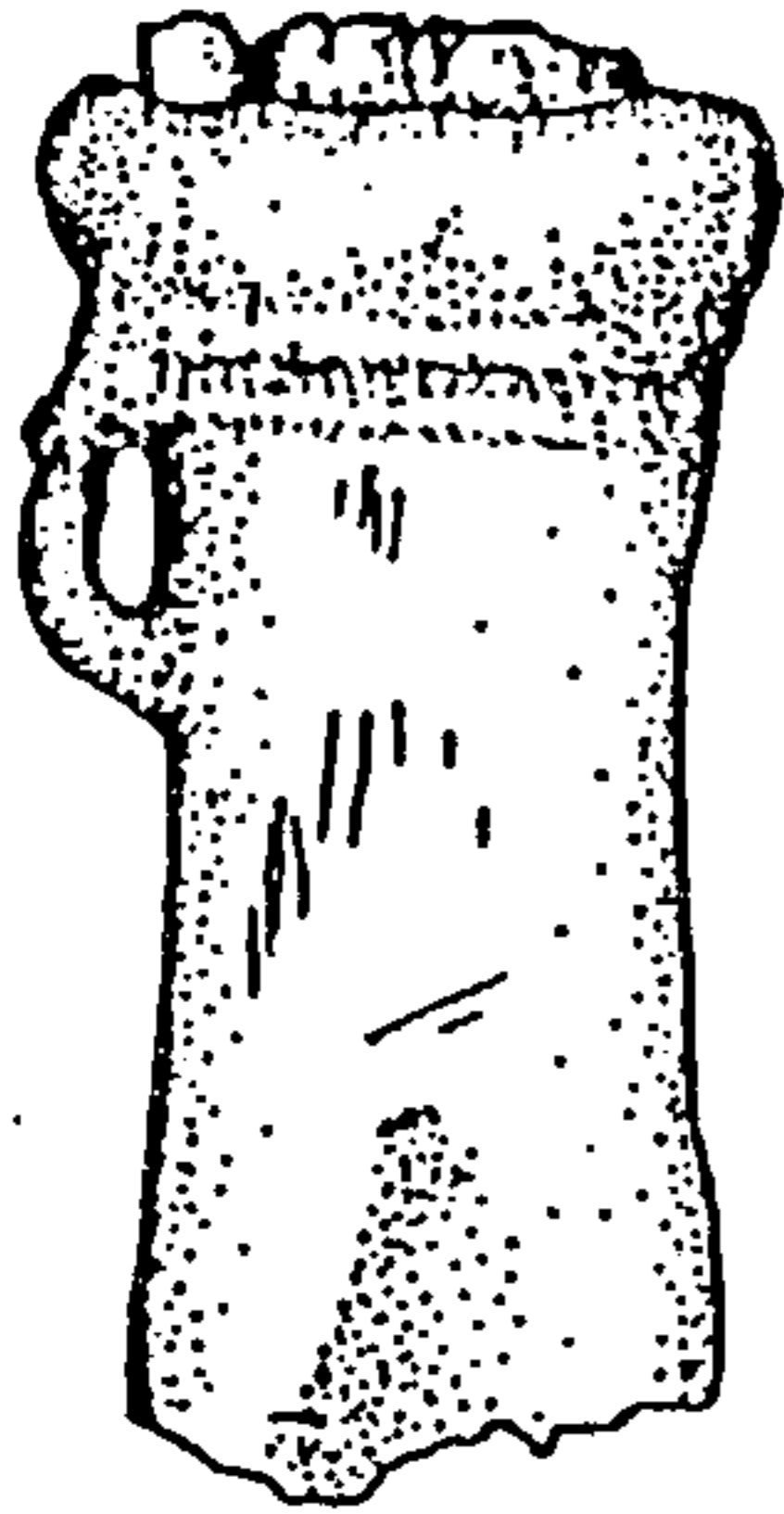
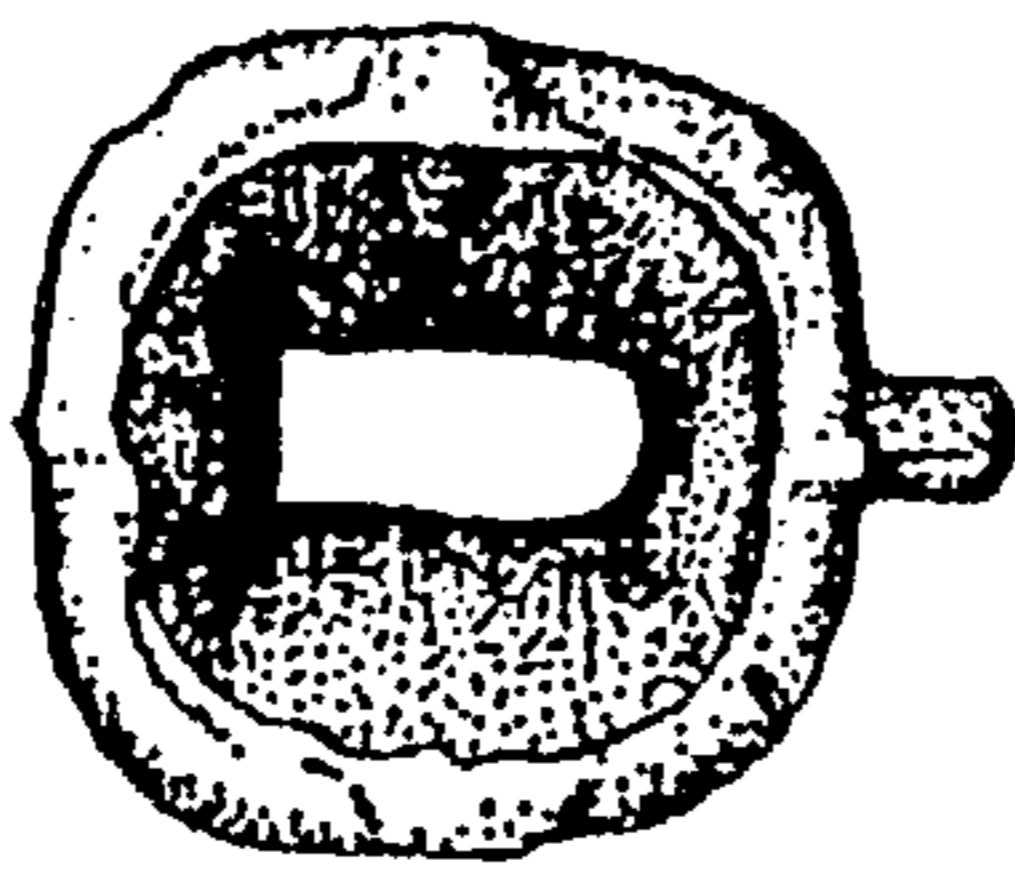


Fig. 26 The Borstal Hoard (Ref. No. 16): Socketed Axes

16/06

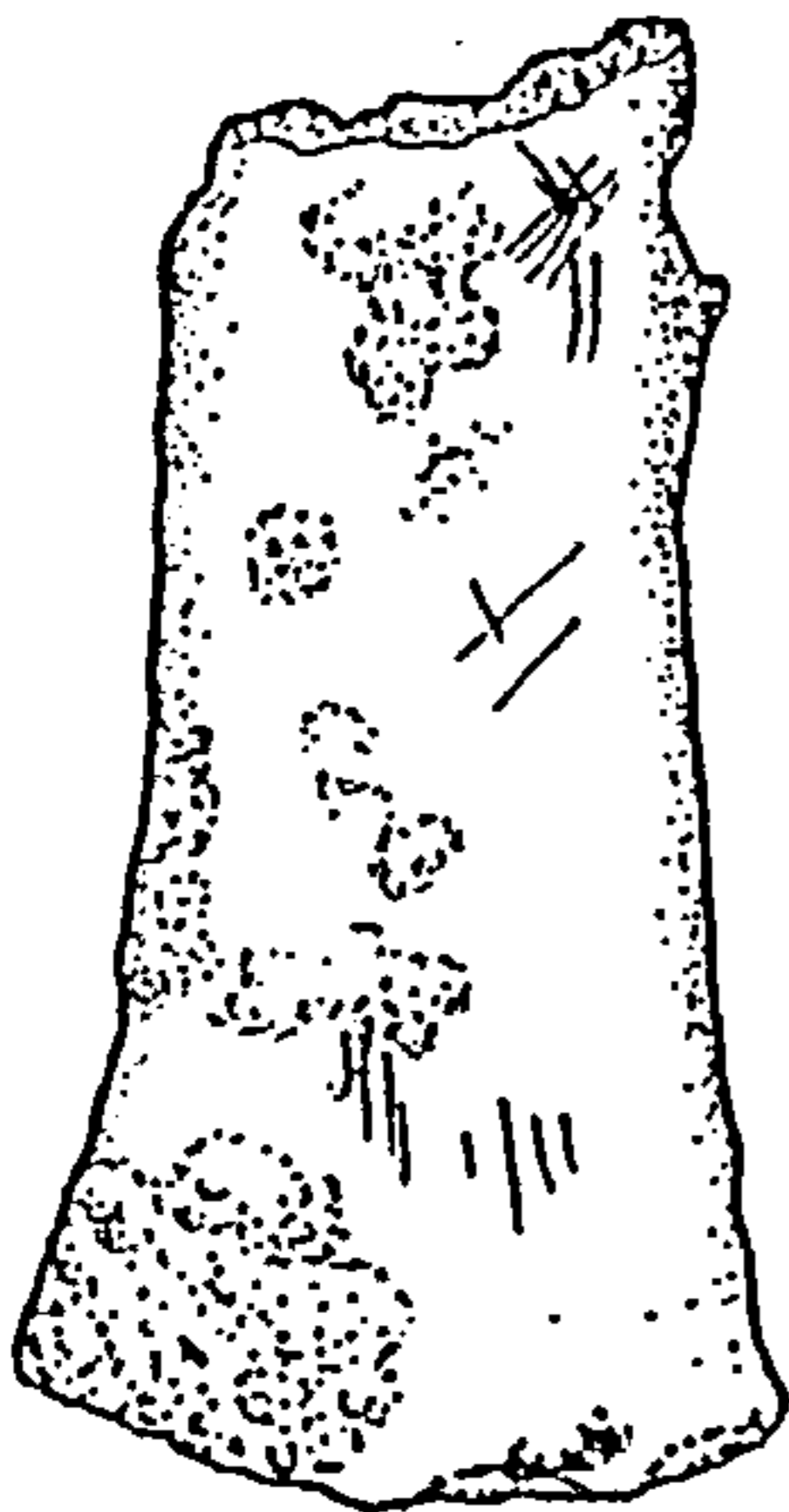


16/07

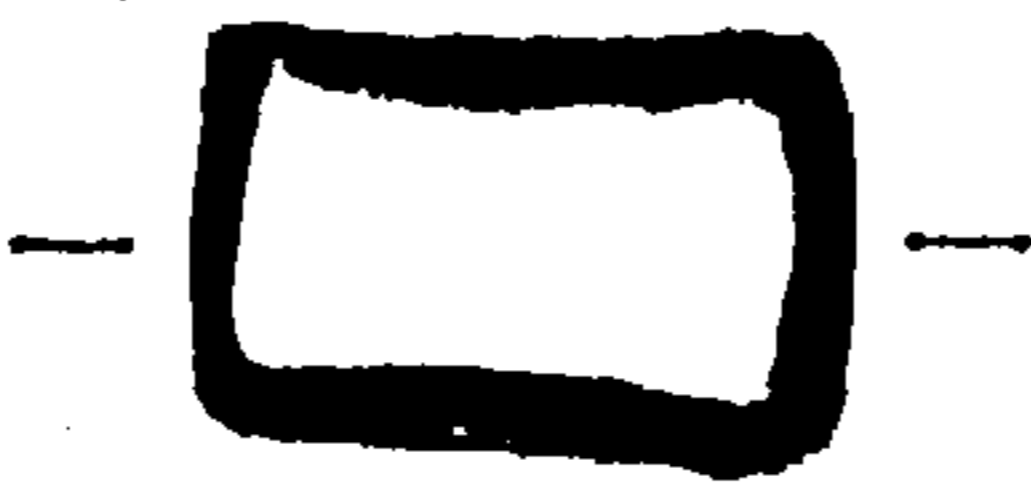


0 2cm

16/08



16/09



16/10

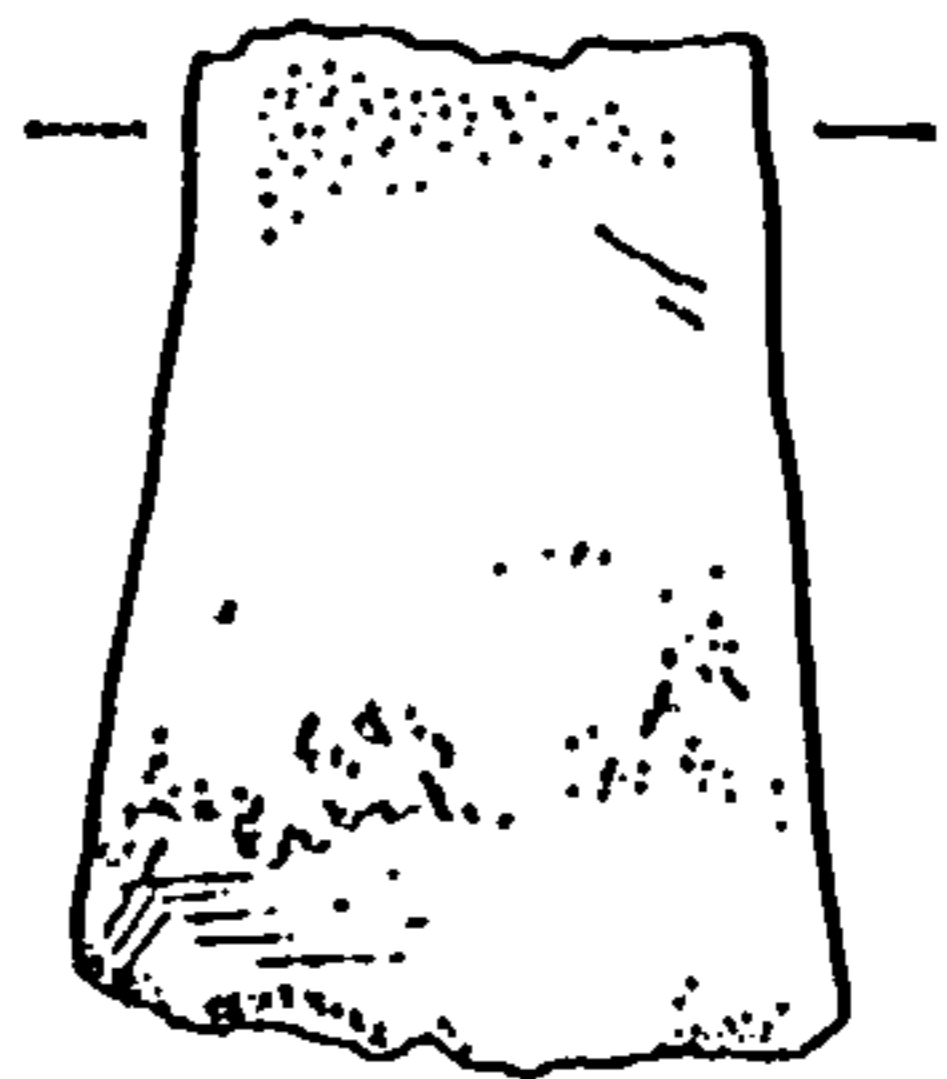
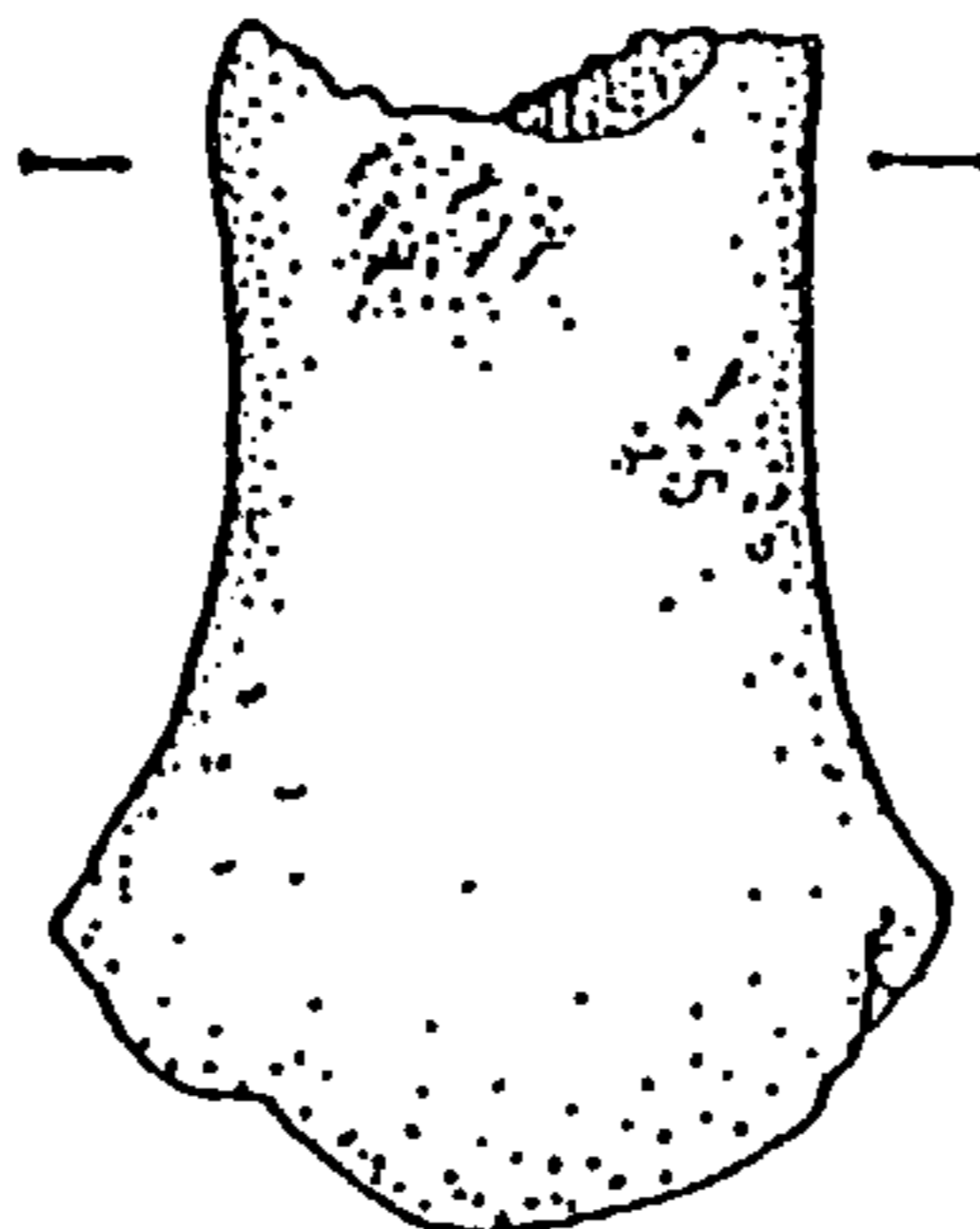
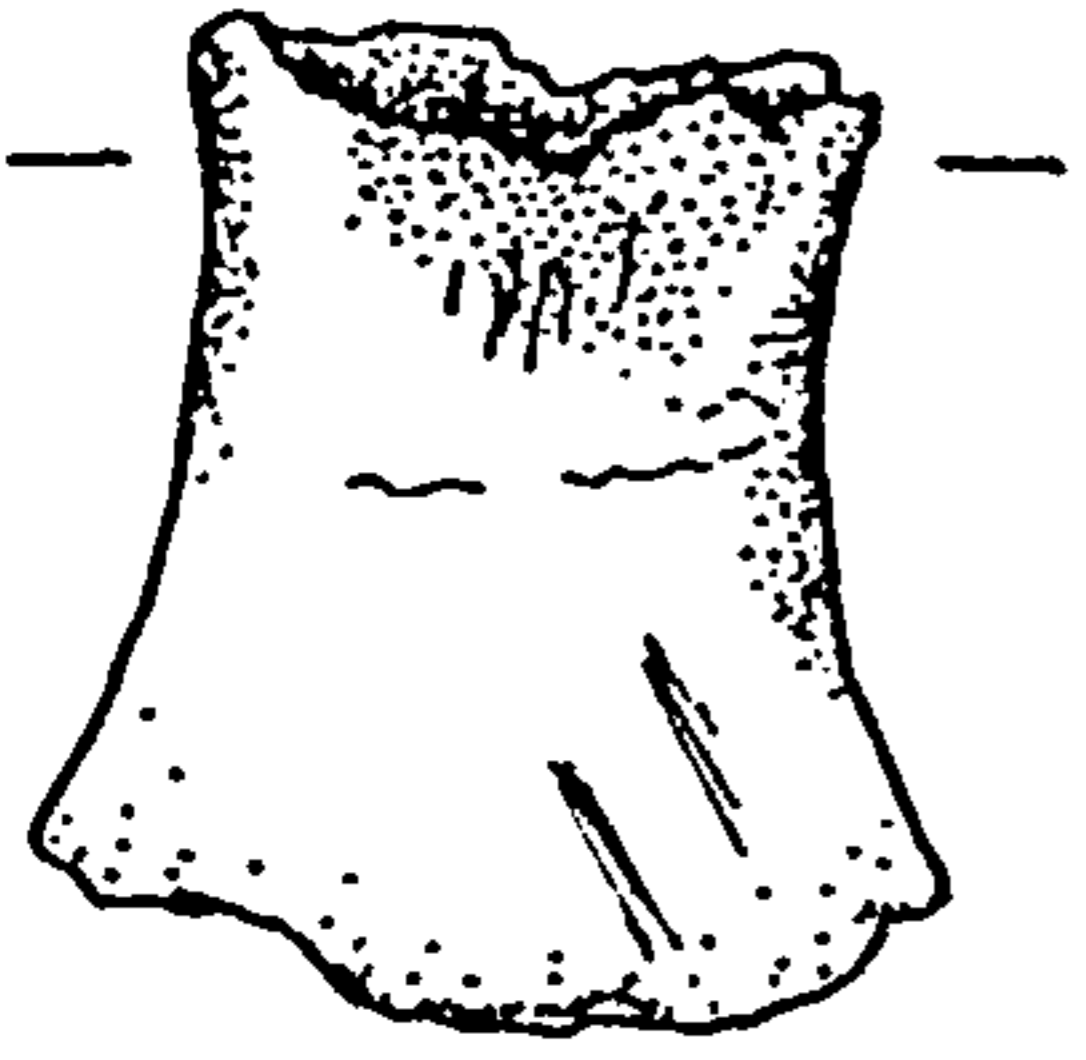


Fig. 27 The Borstal Hoard (Ref. No. 16): Socketed Axe Fragments (i)

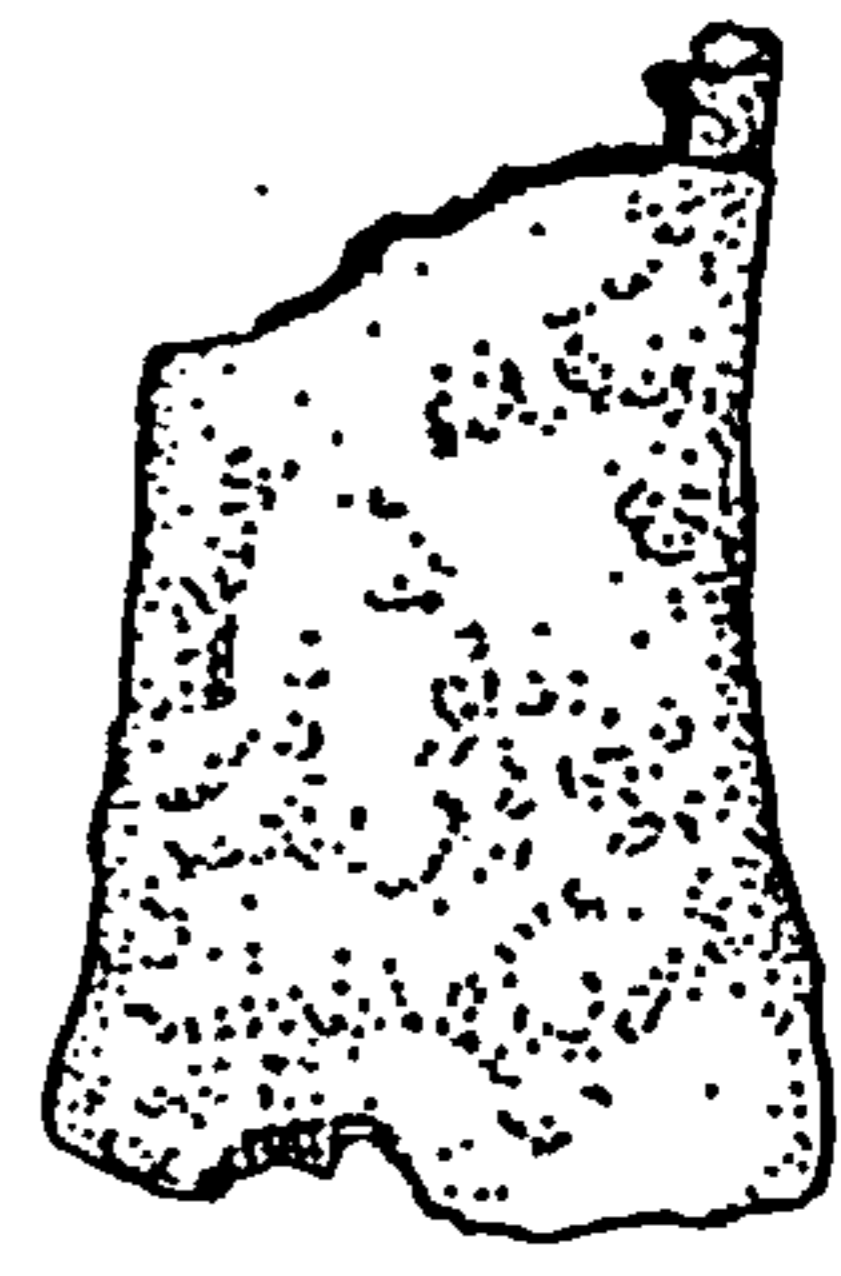
16/11



16/12



16/13



16/14

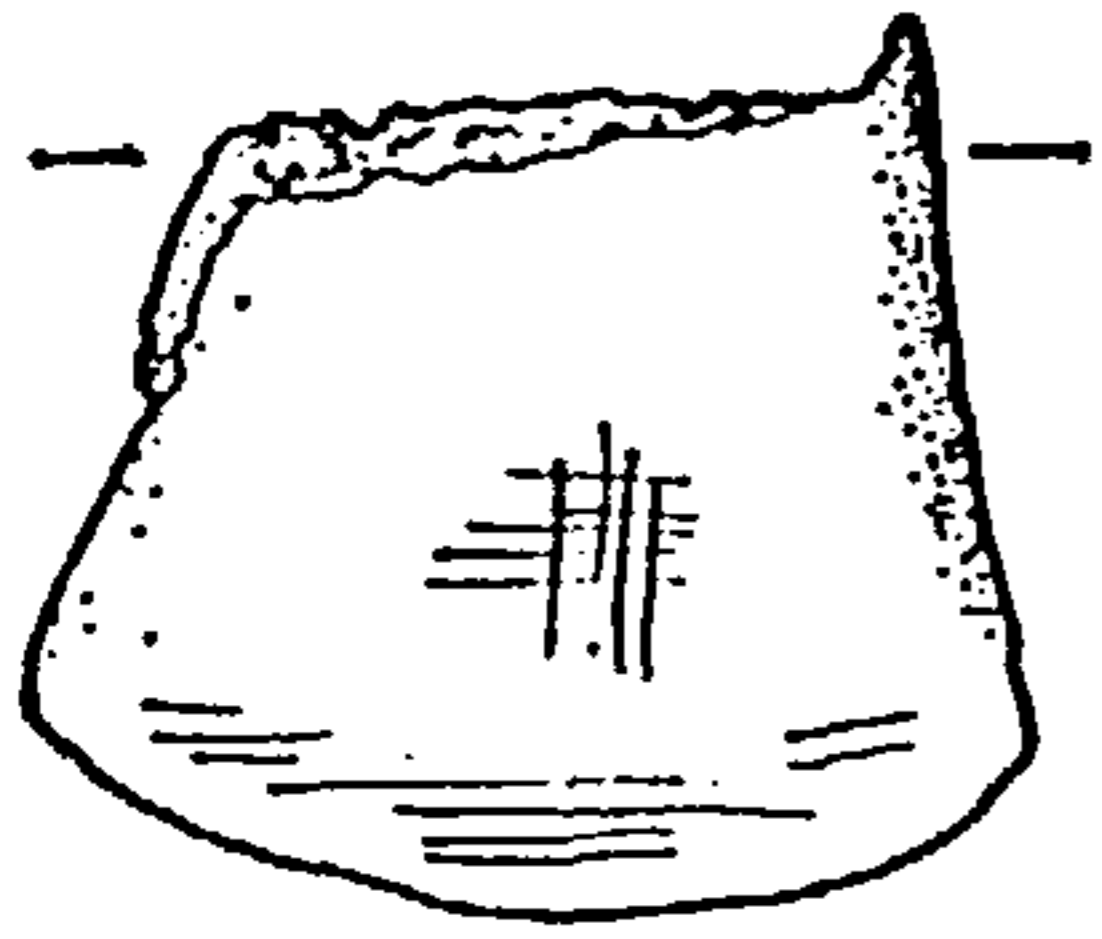
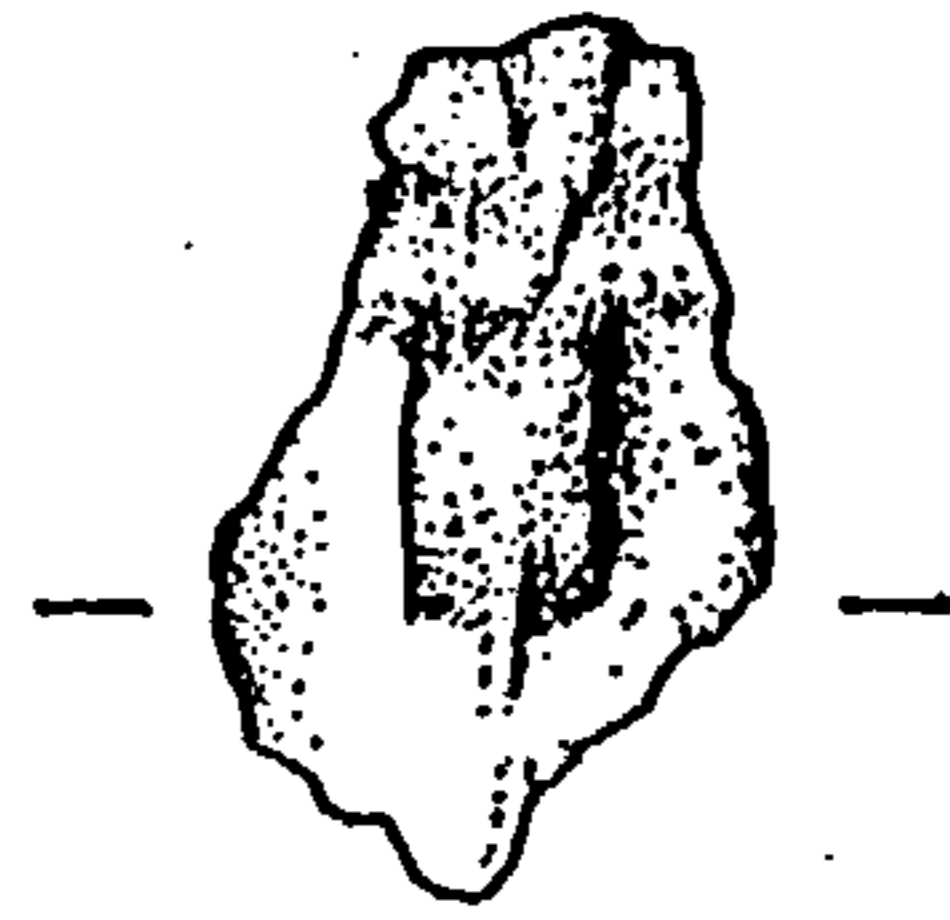




0 2cm

16/15



16/16



 Lead Infill
 Rough Metal/Corrosion Product



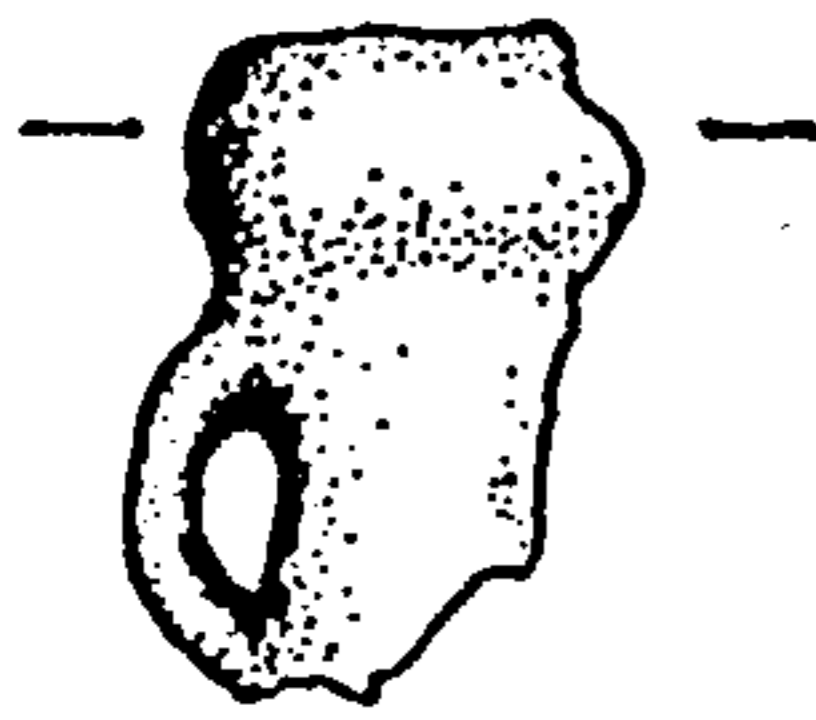
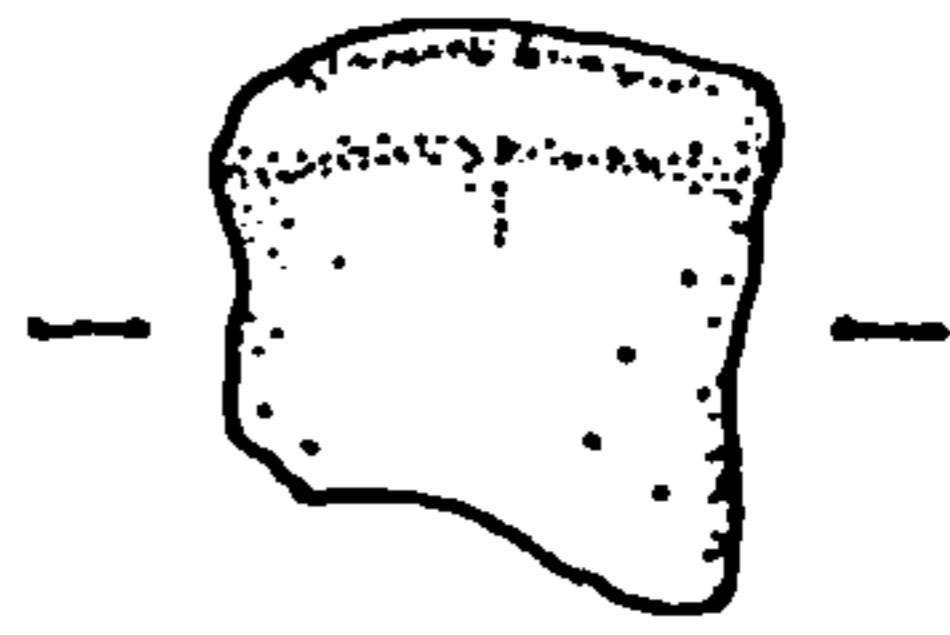
16/17



16/18



16/20



16/19

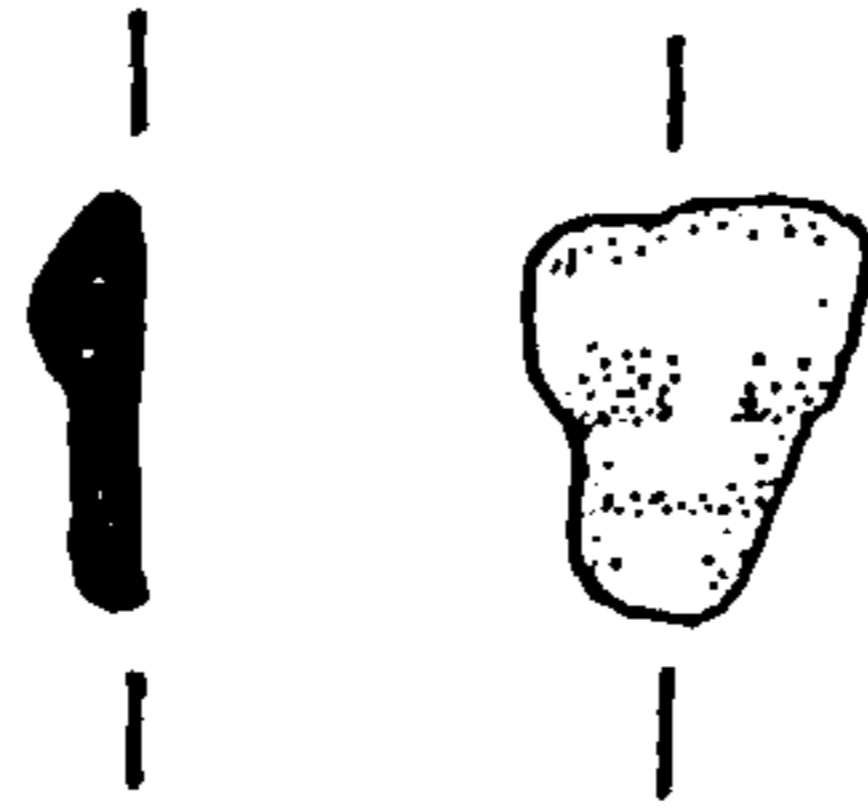
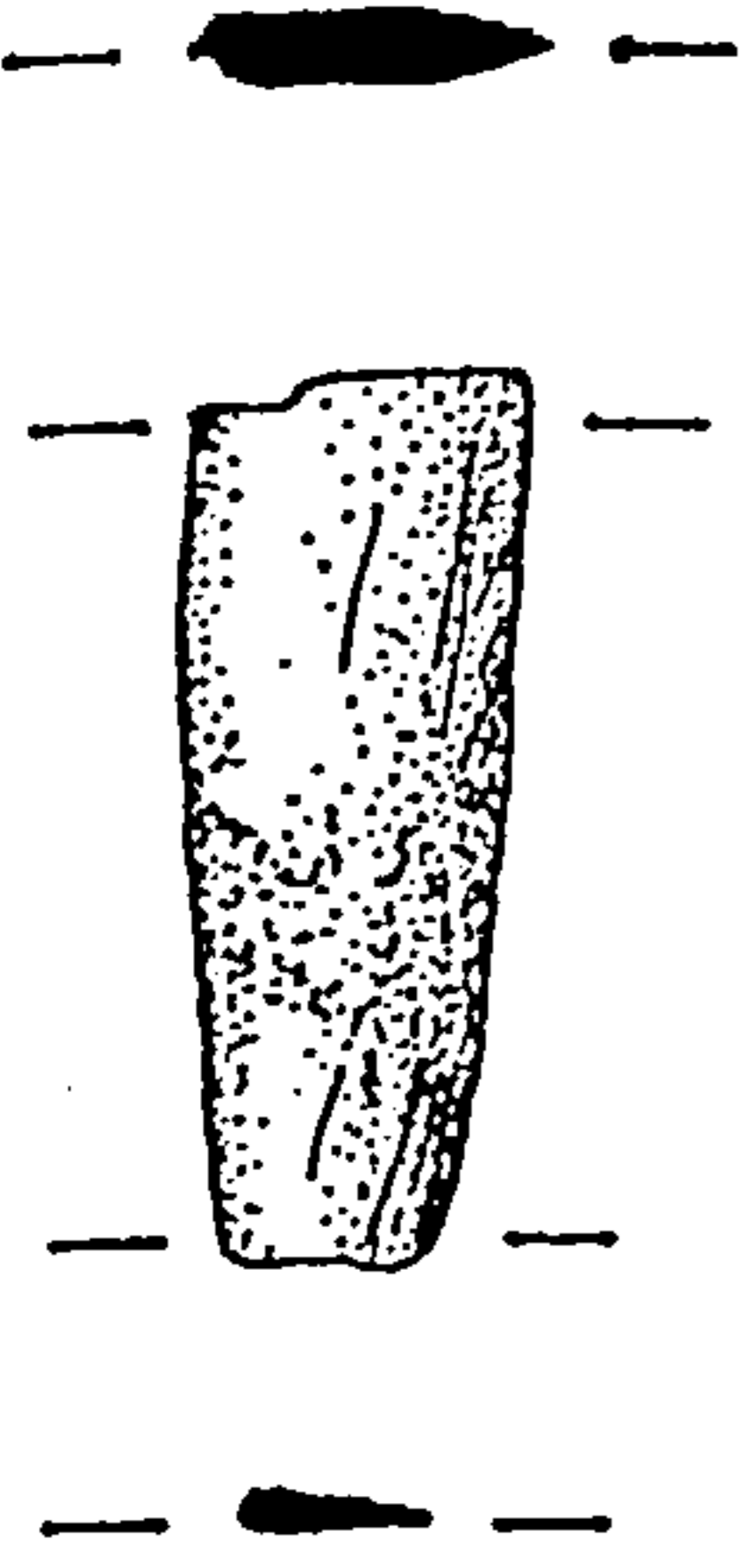
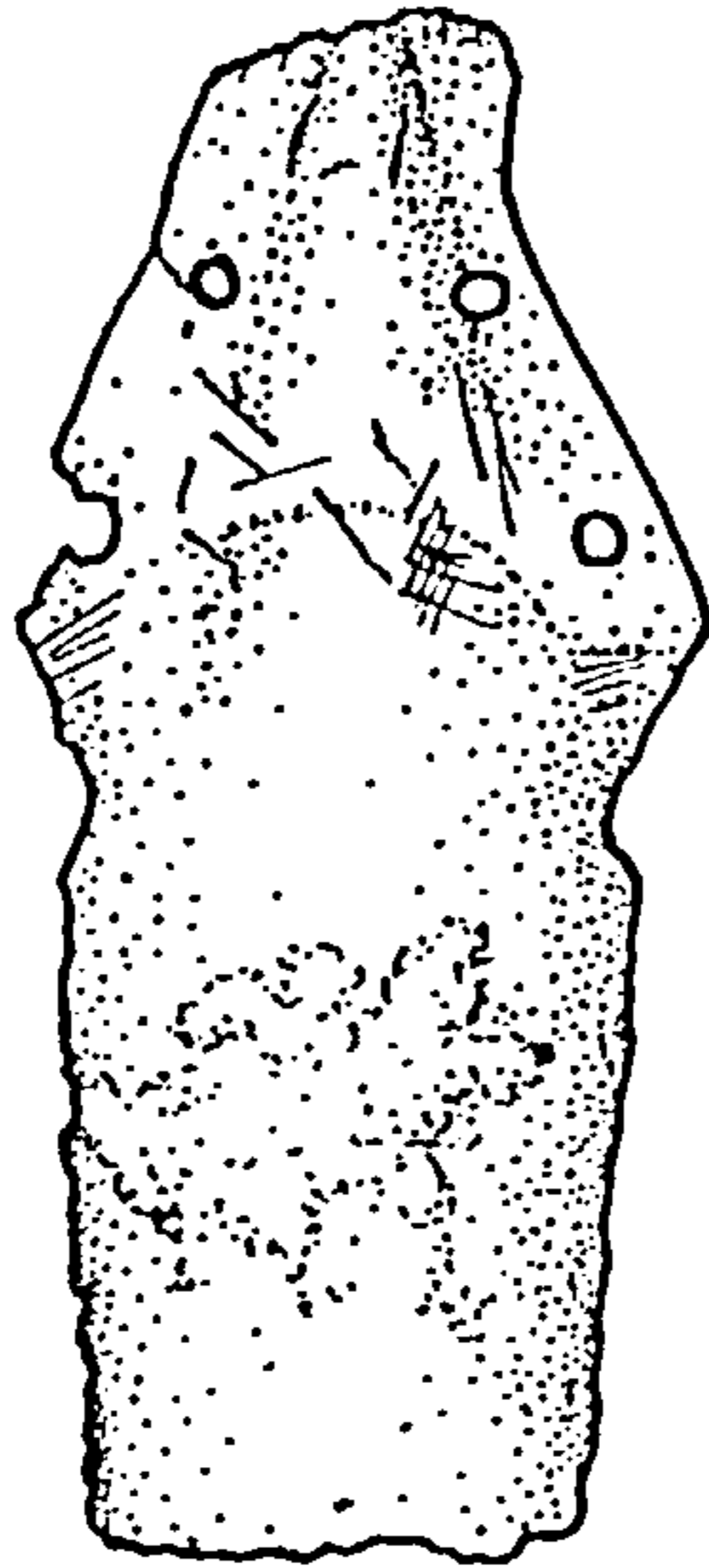


Fig. 28 The Borstal Hoard (Ref. No. 16): Socketed Axe Fragments (ii)

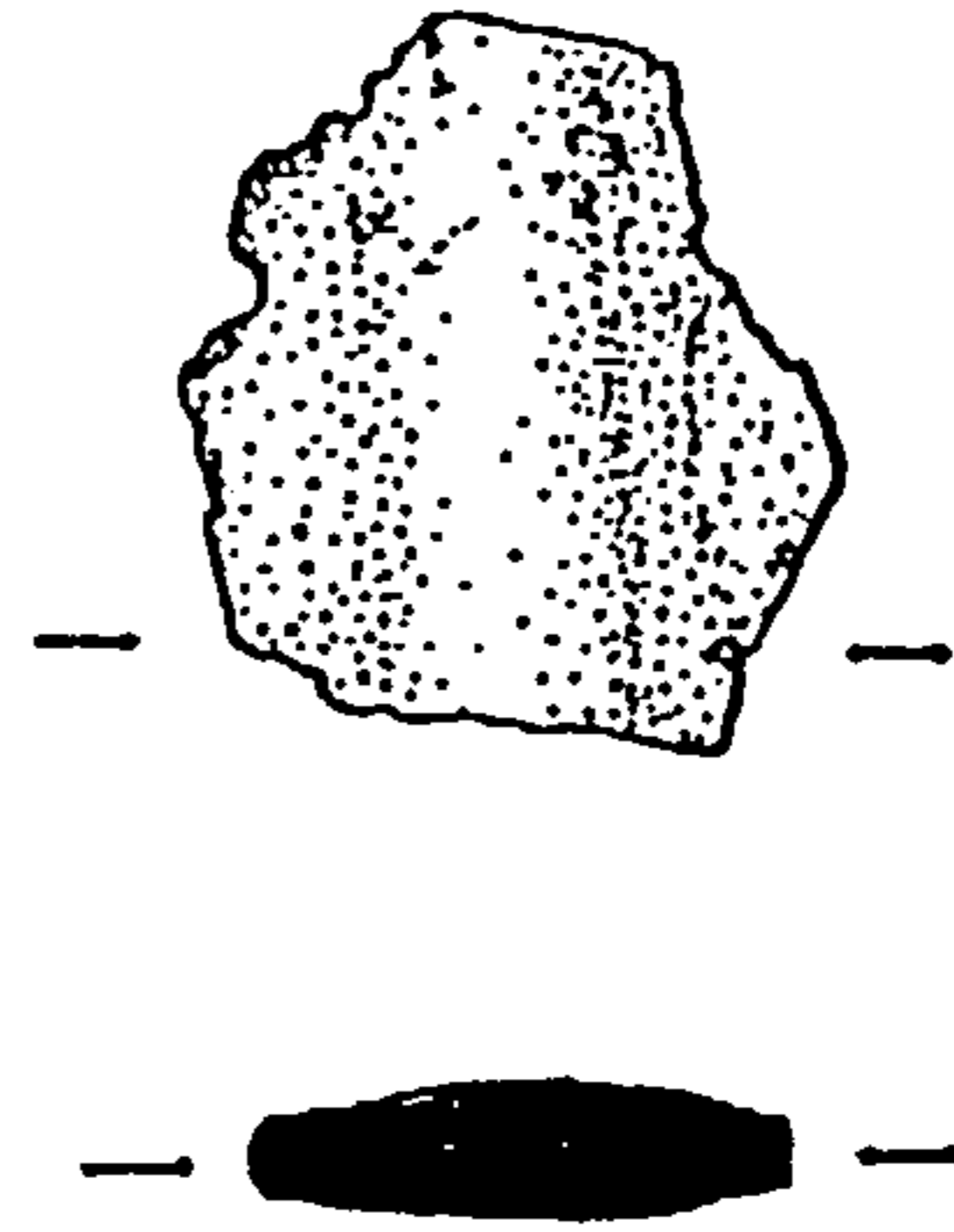
16/21



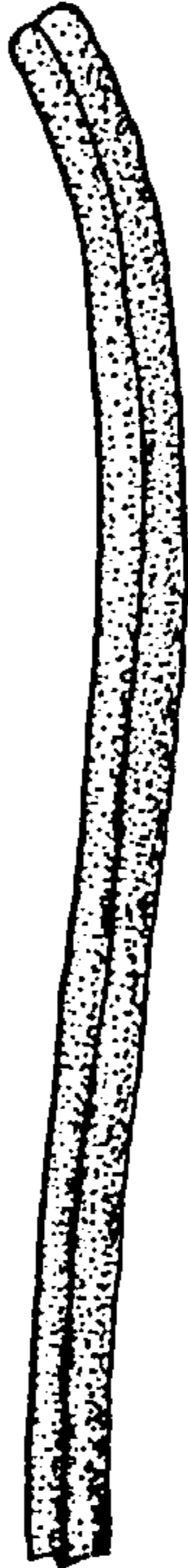
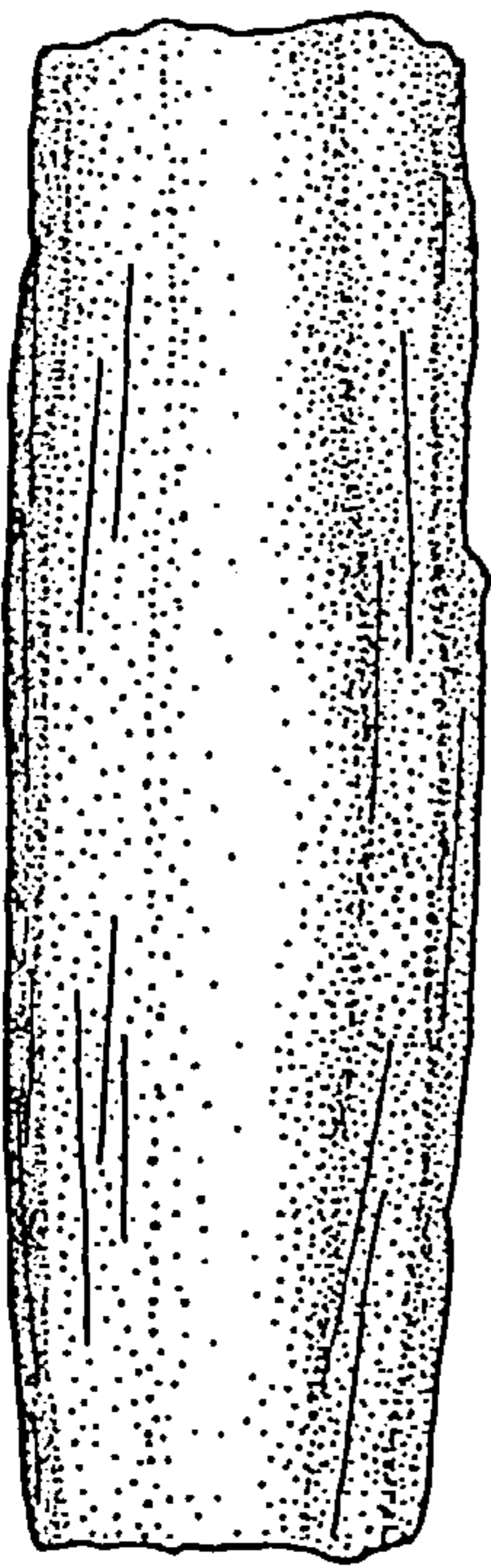
16/22



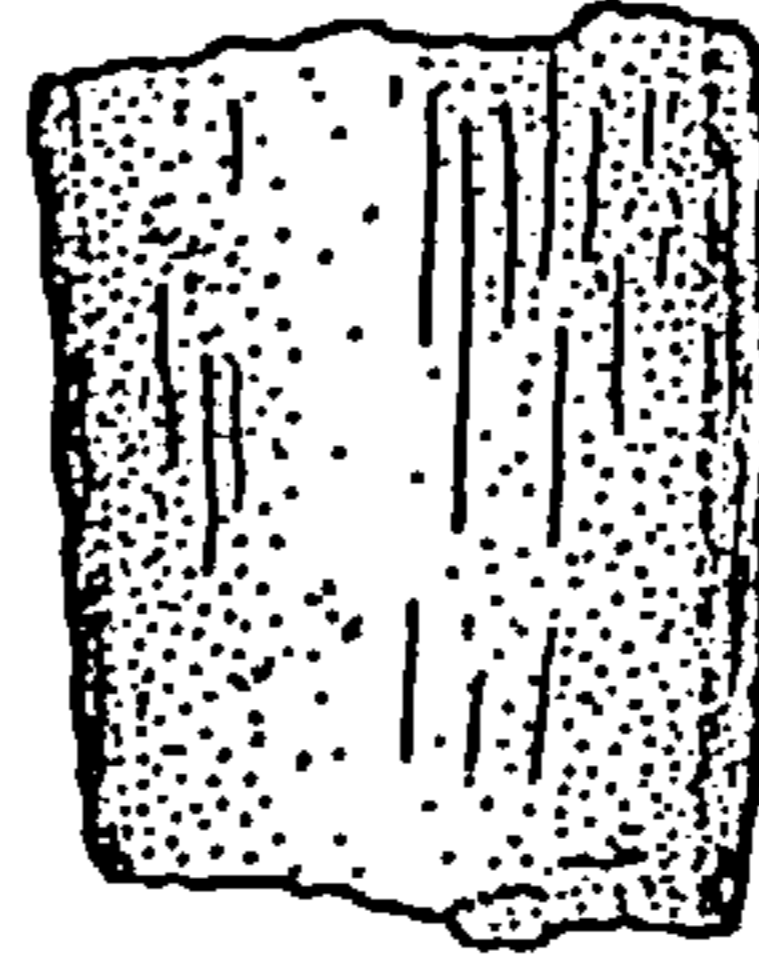
16/23



16/24



16/25



16/26

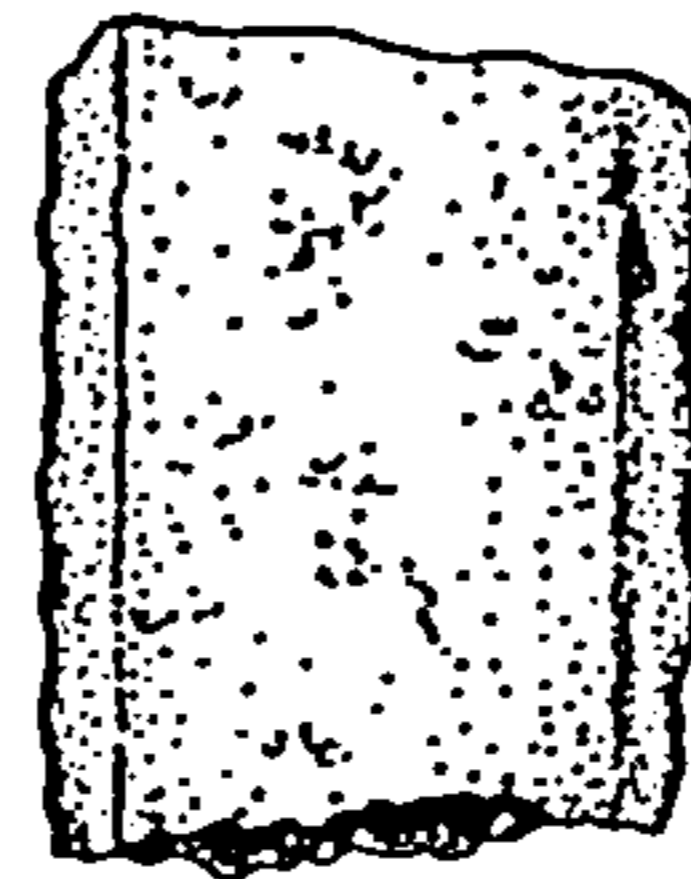
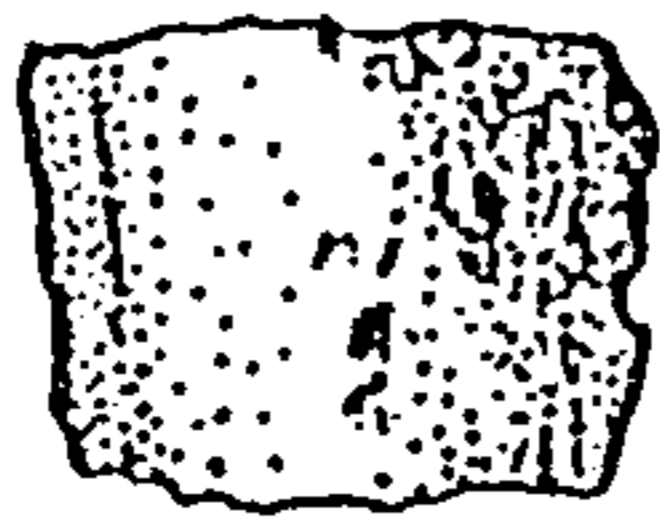
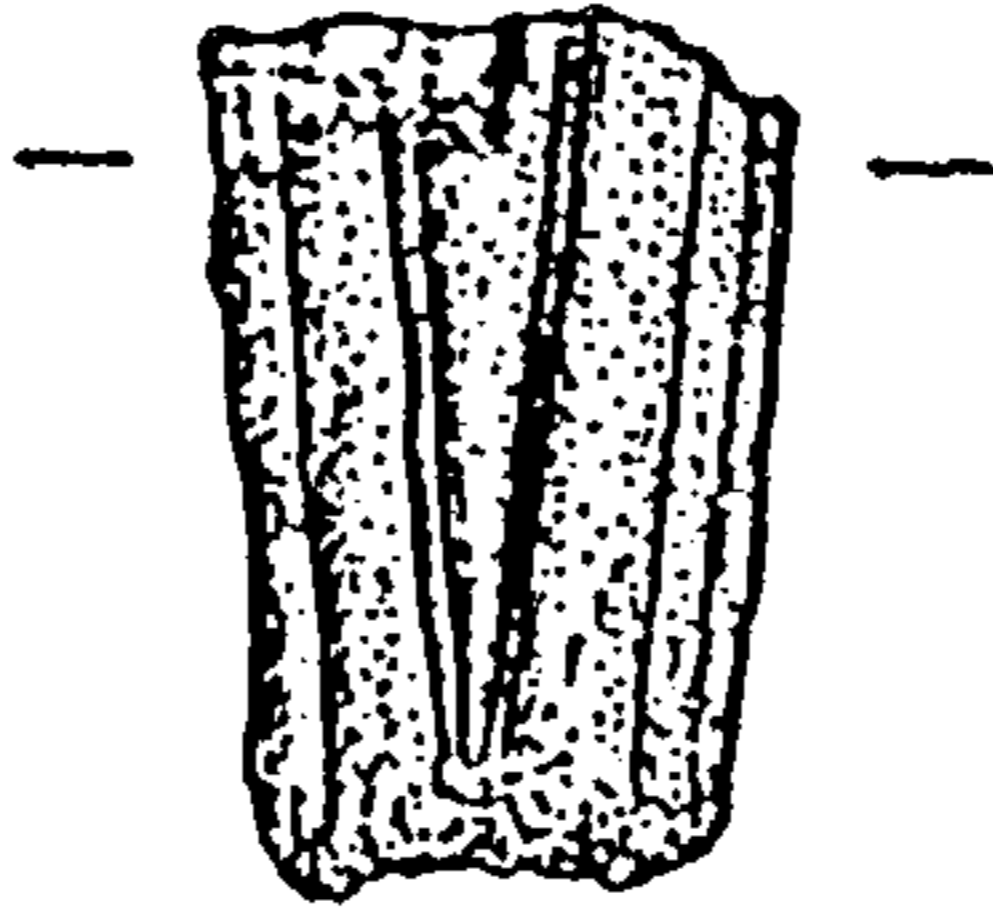


Fig. 29 The Borstal Hoard (Ref. No. 16): Knife and Sword Fragments

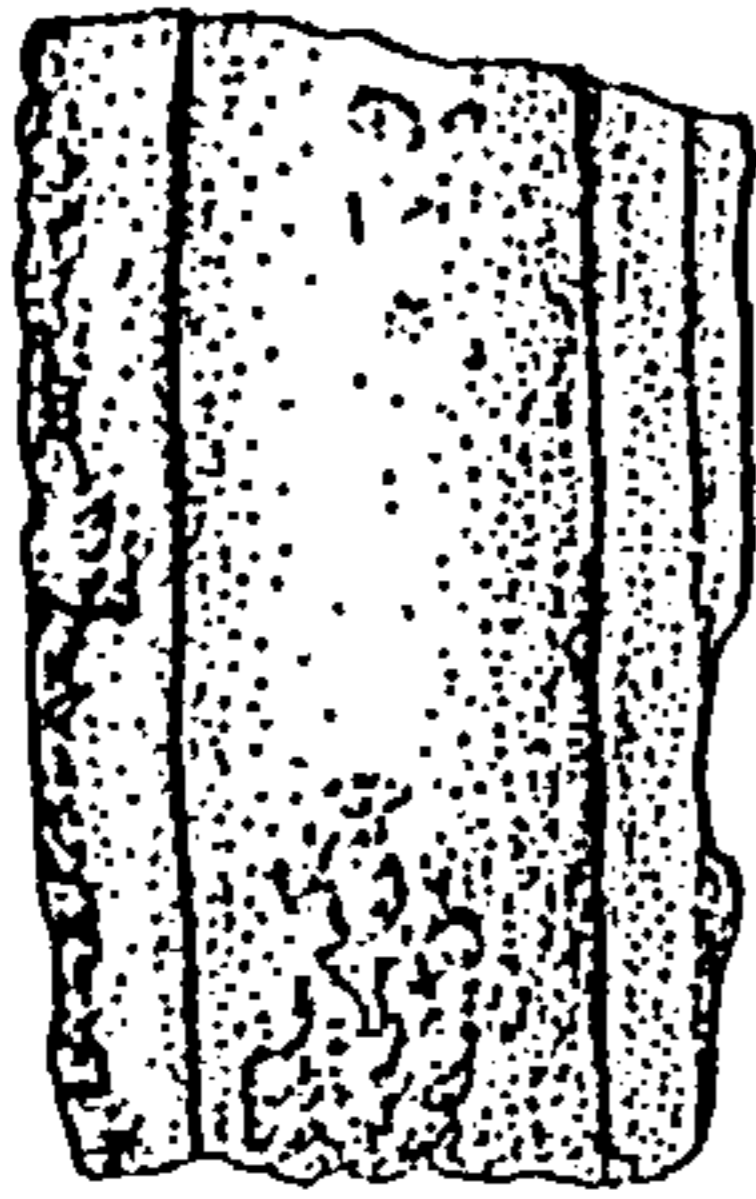
16/27



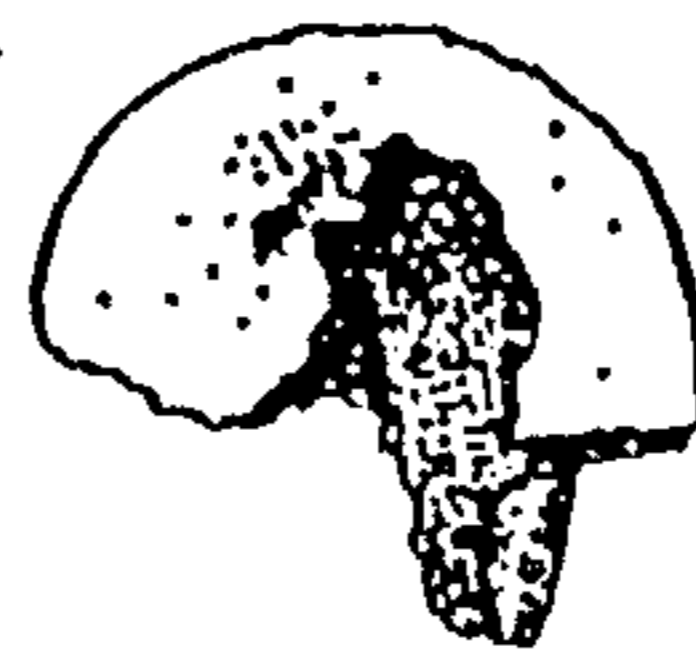
16/28



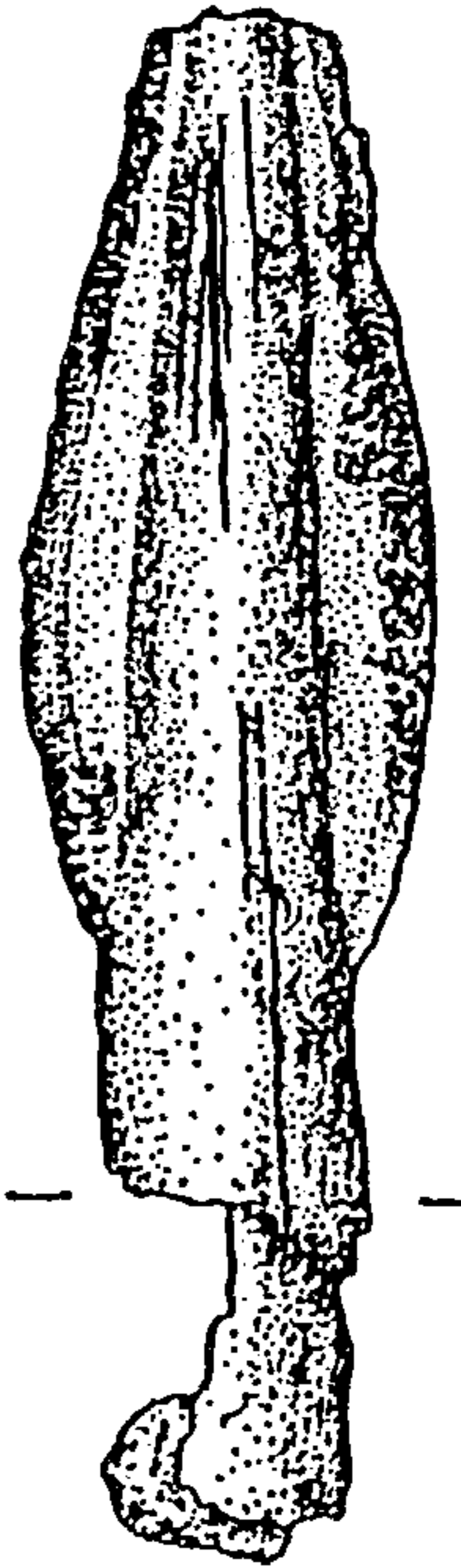
16/29



16/30



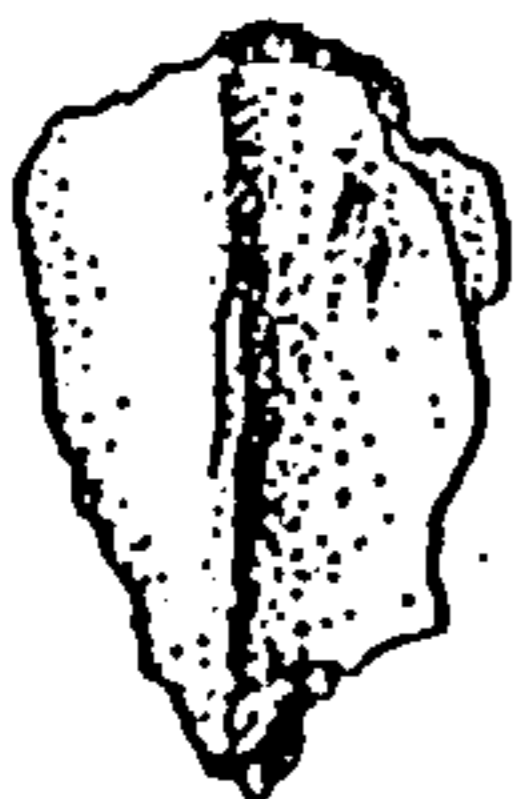
16/31



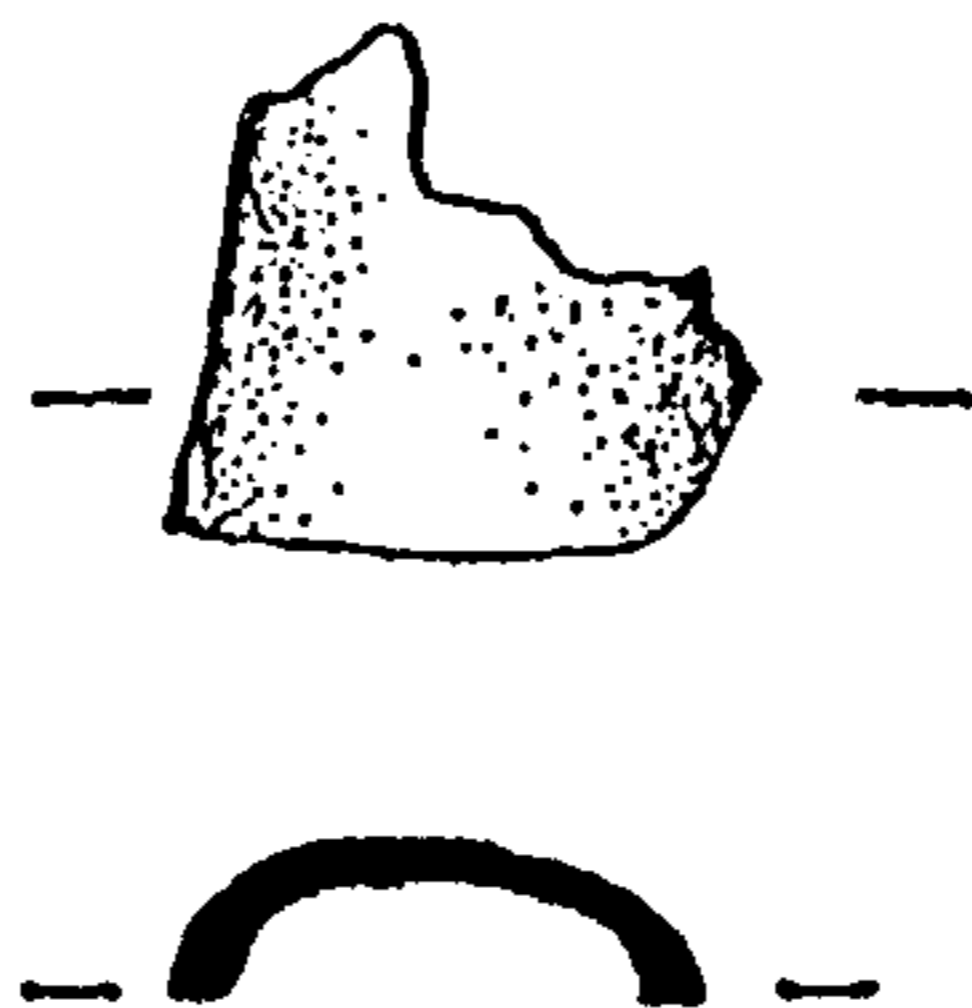
0 2cm



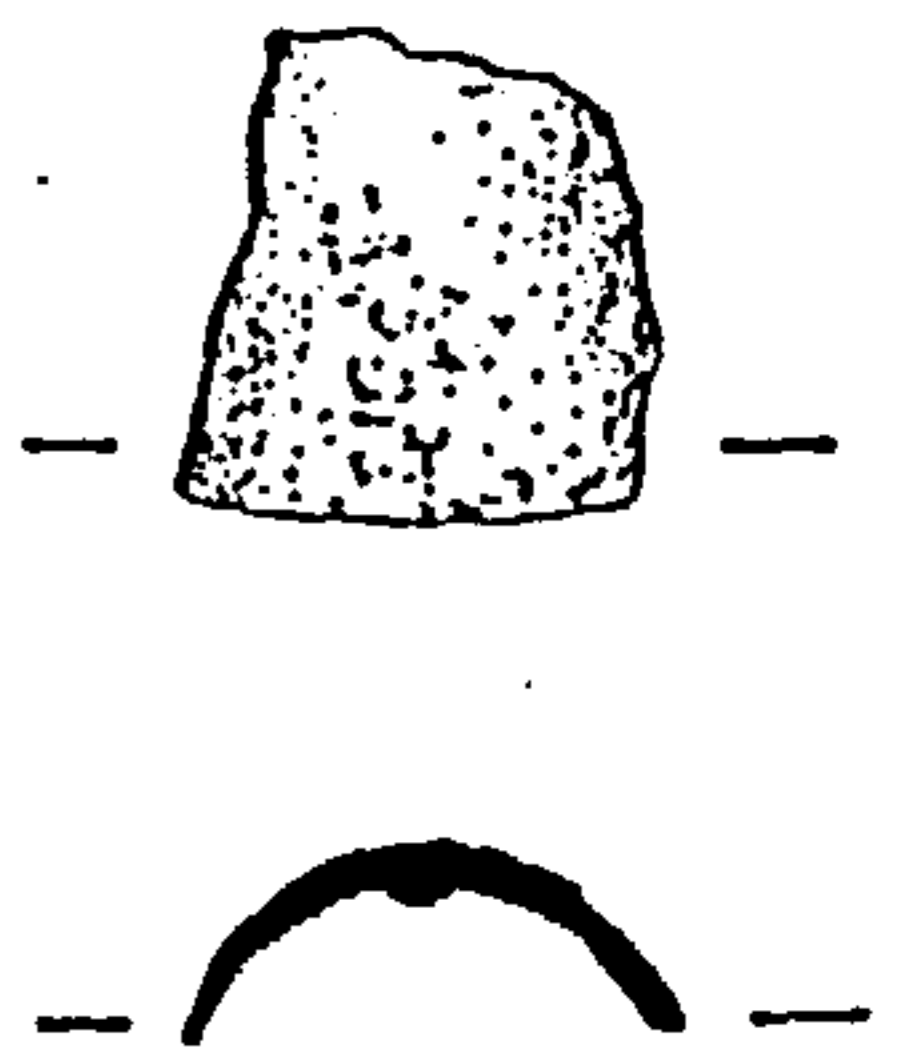
16/32



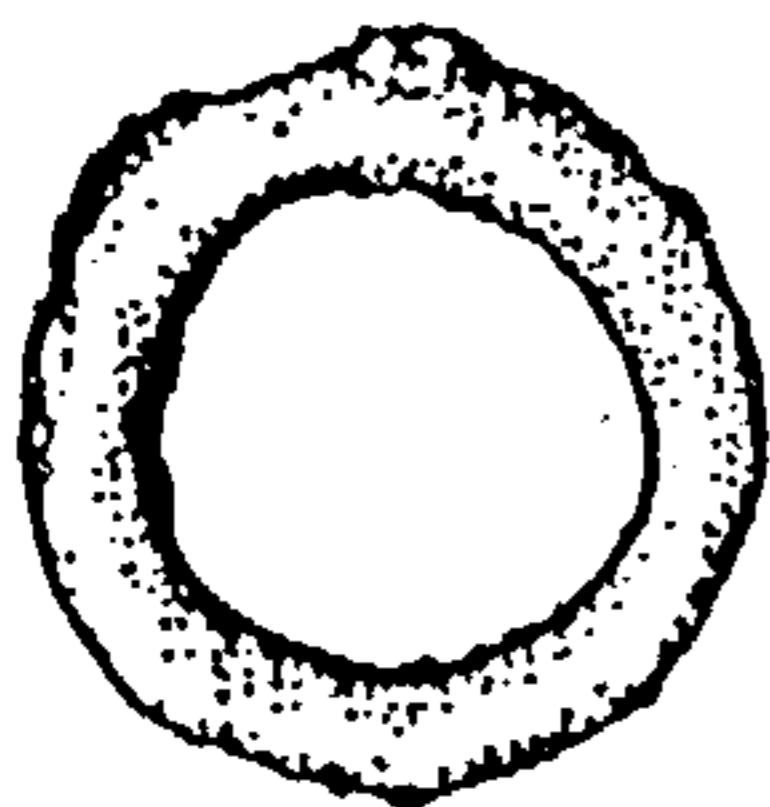
16/33



16/34



16/35



16/36



16/37



Fig. 30 The Borstal Hoard (Ref. No. 16): Weapons and Miscellaneous Items

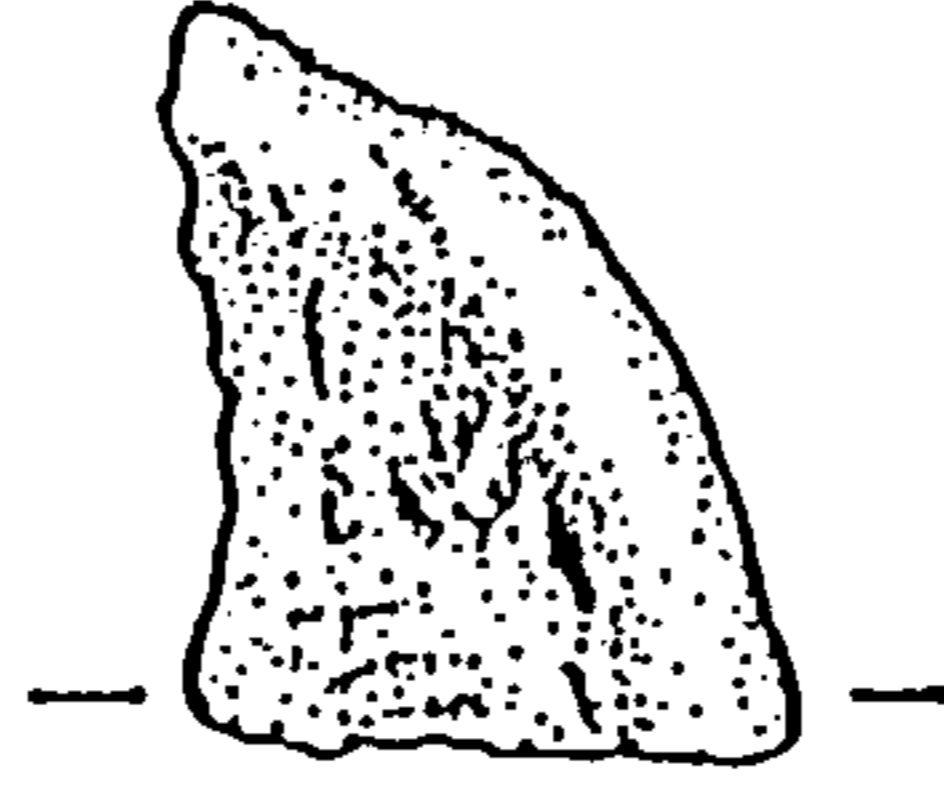
16/38



16/39

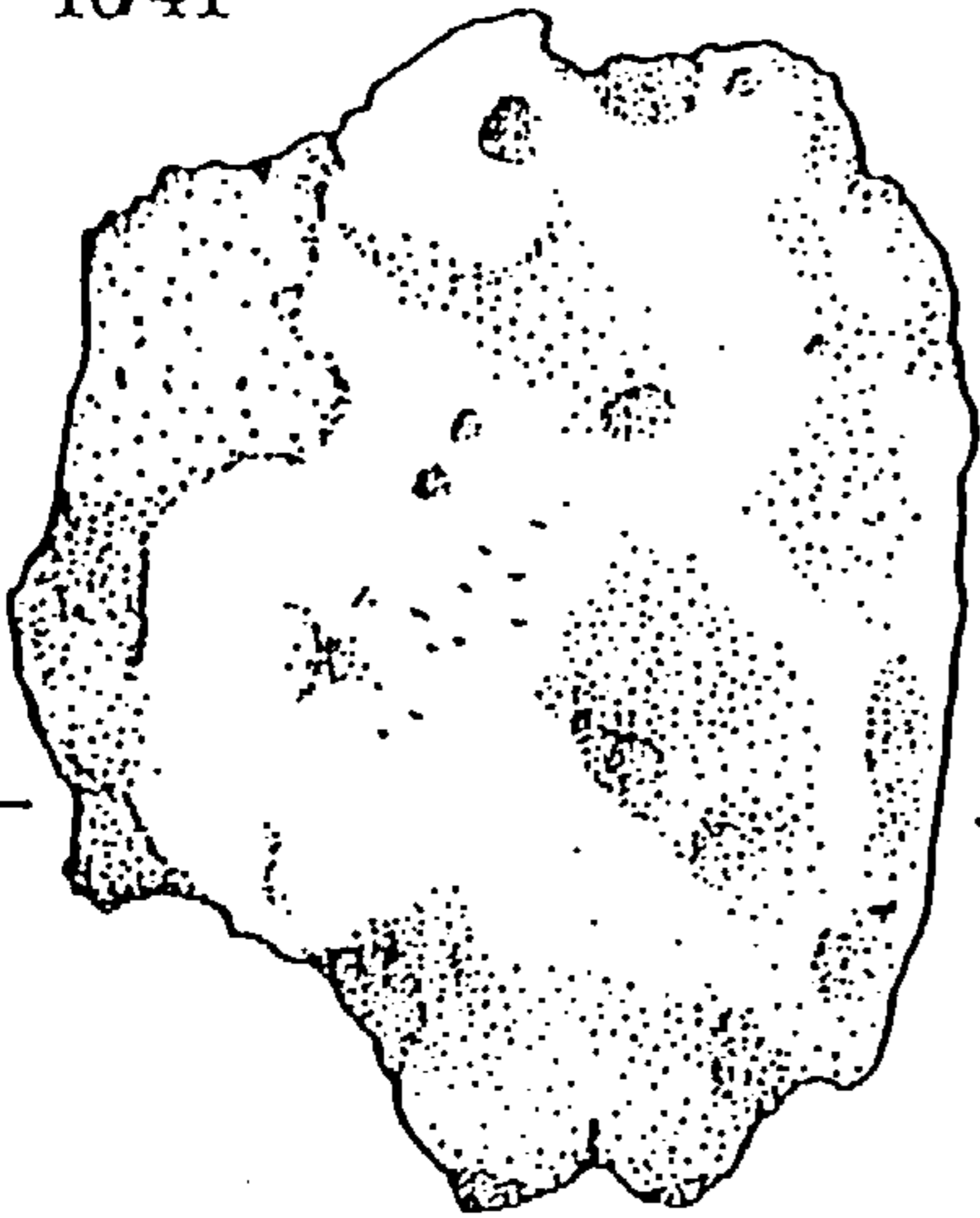


16/40

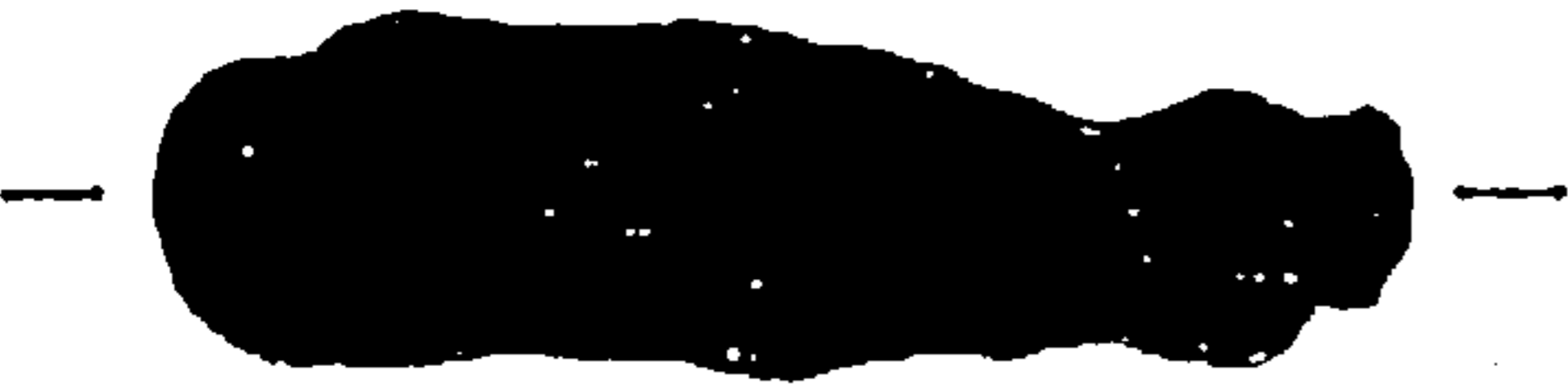
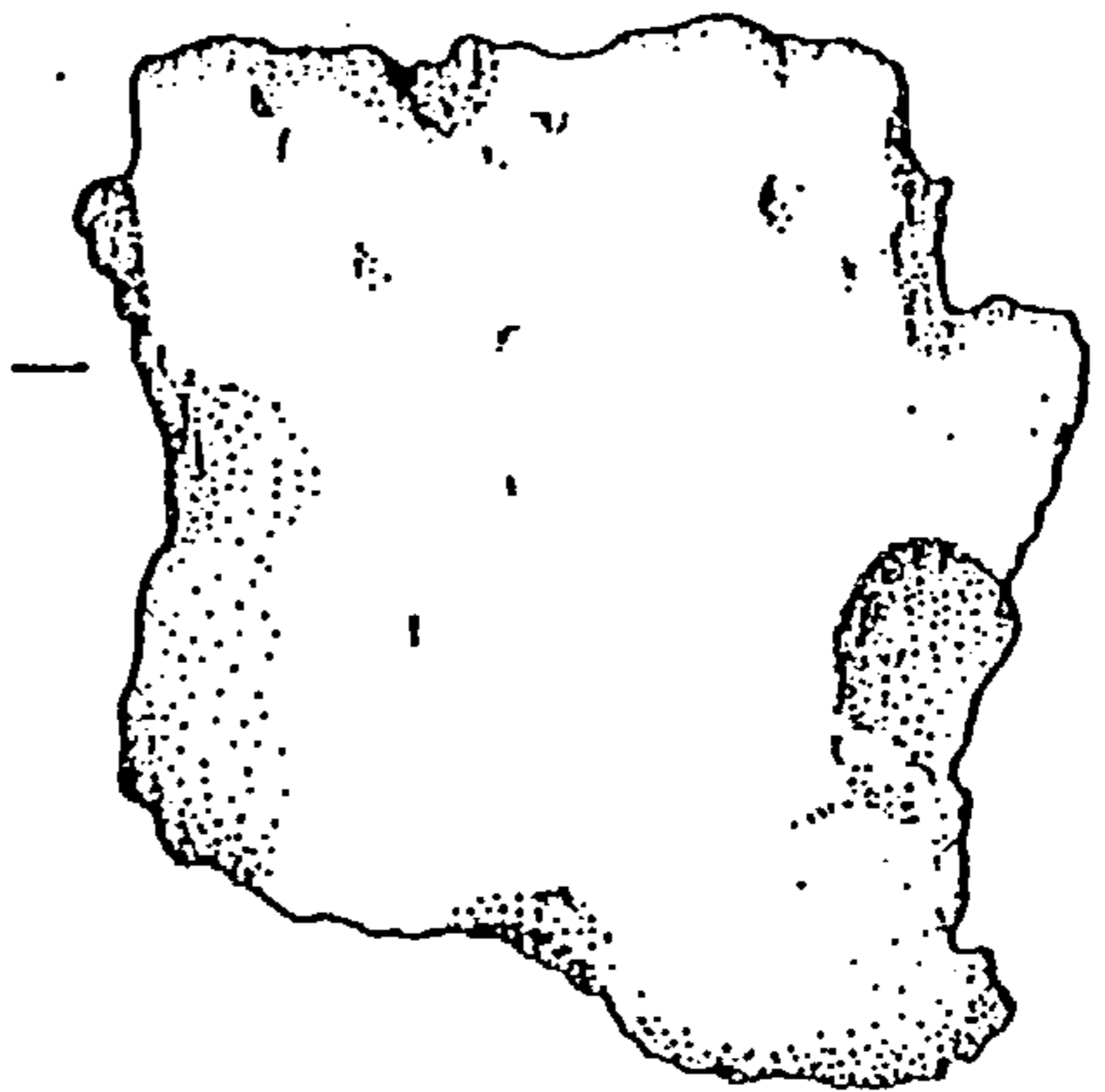


0 2cm

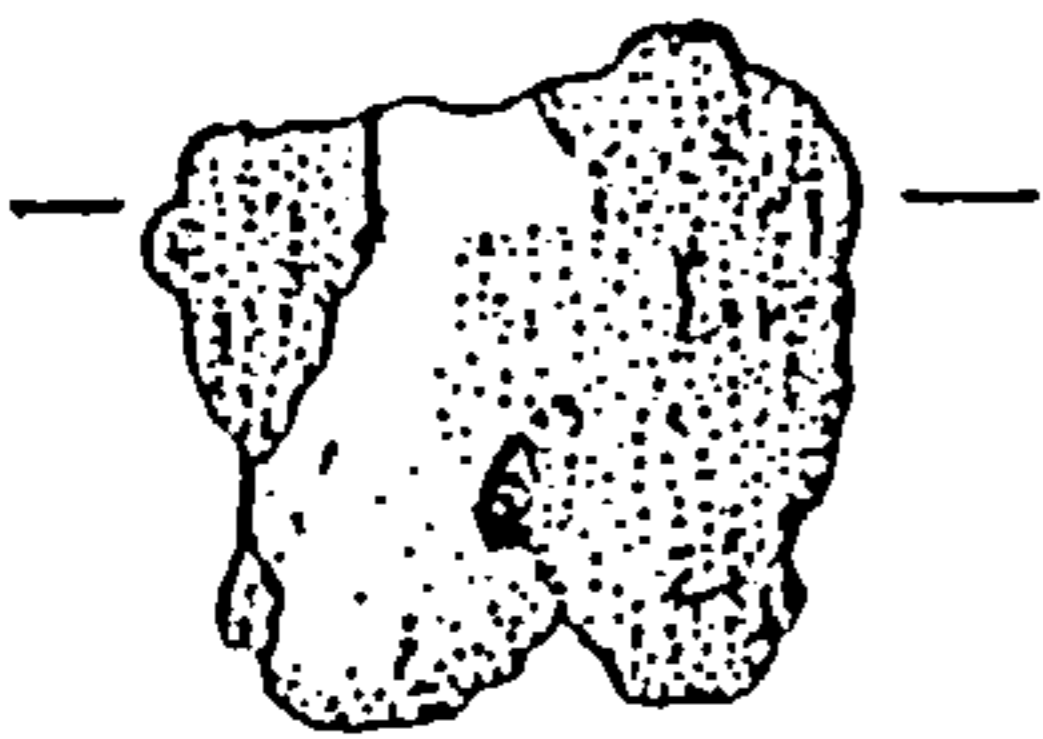
16/41



16/42



16/43



16/44

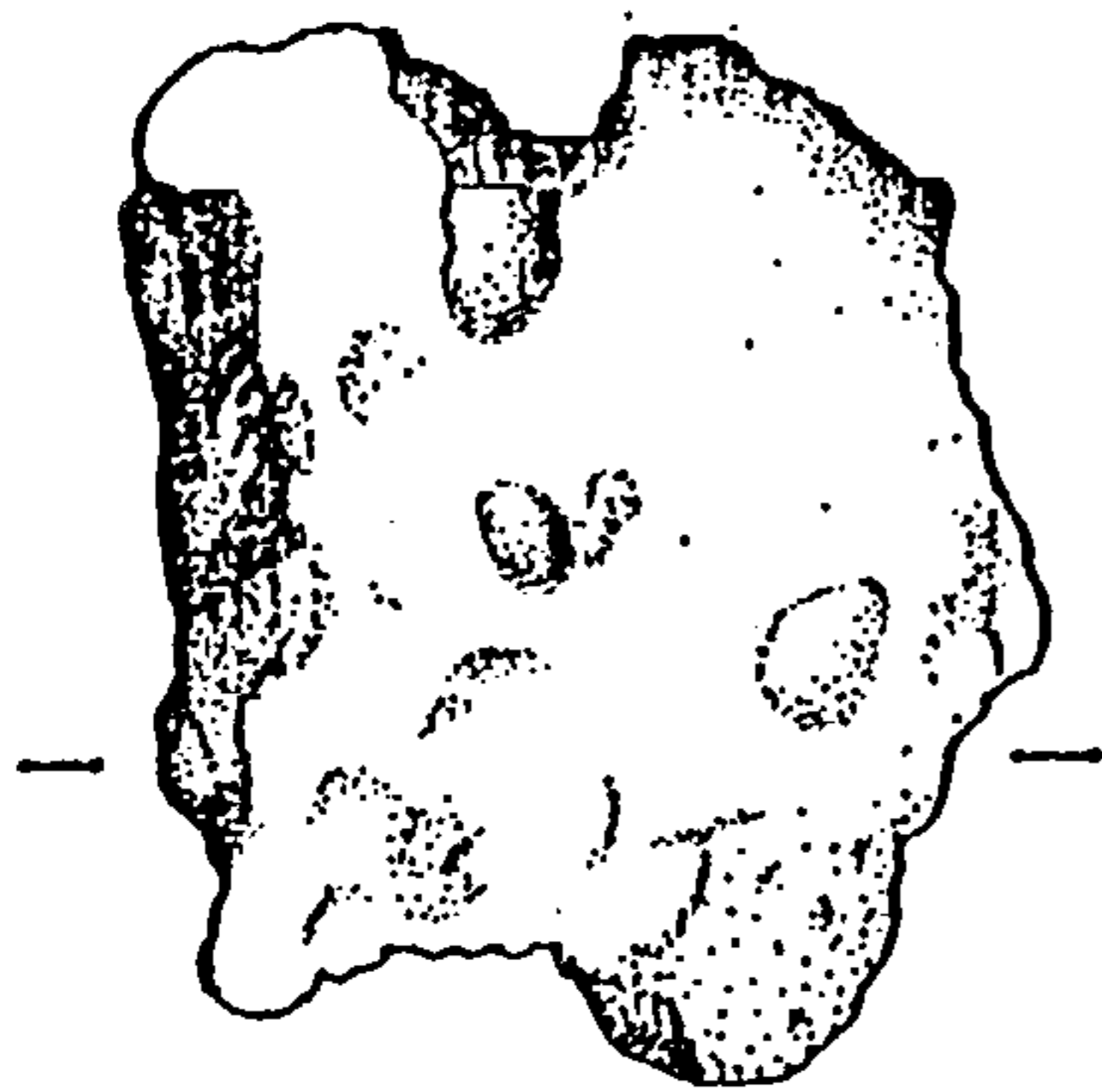


16/45

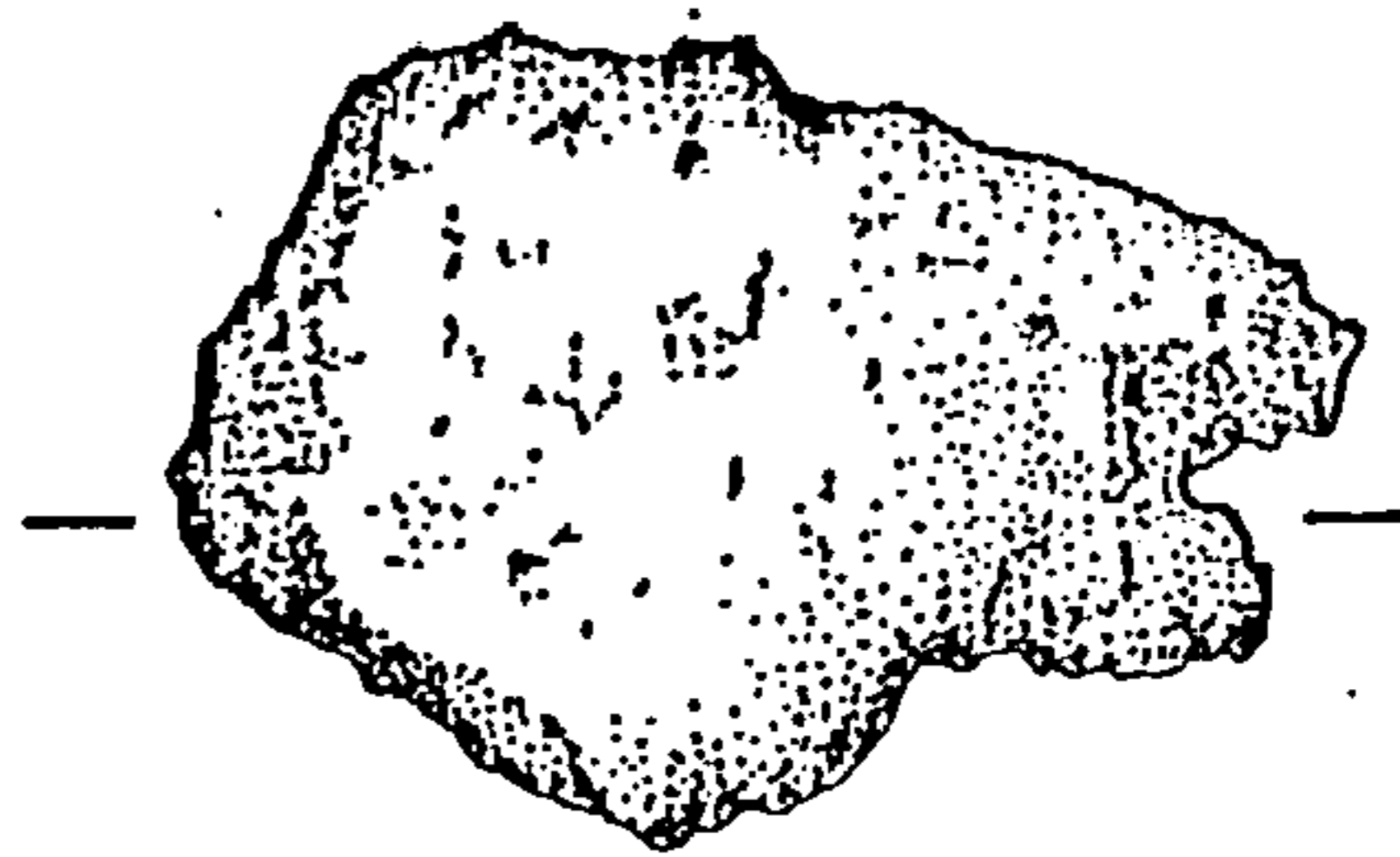


Fig. 31 The Borstal Hoard (Ref. No. 16): Casting Debris and Ingot Metal (i)

16/46

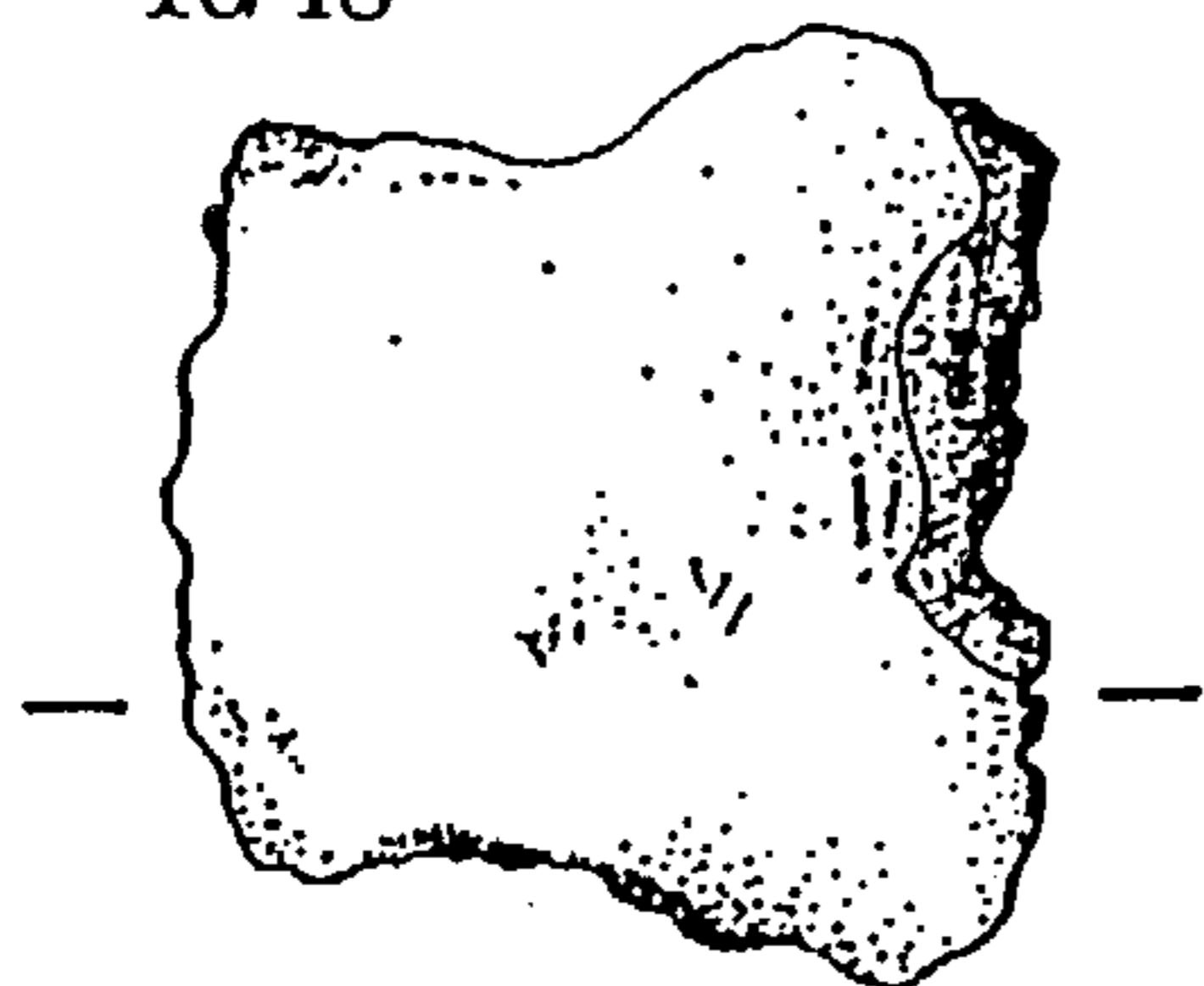


16/47

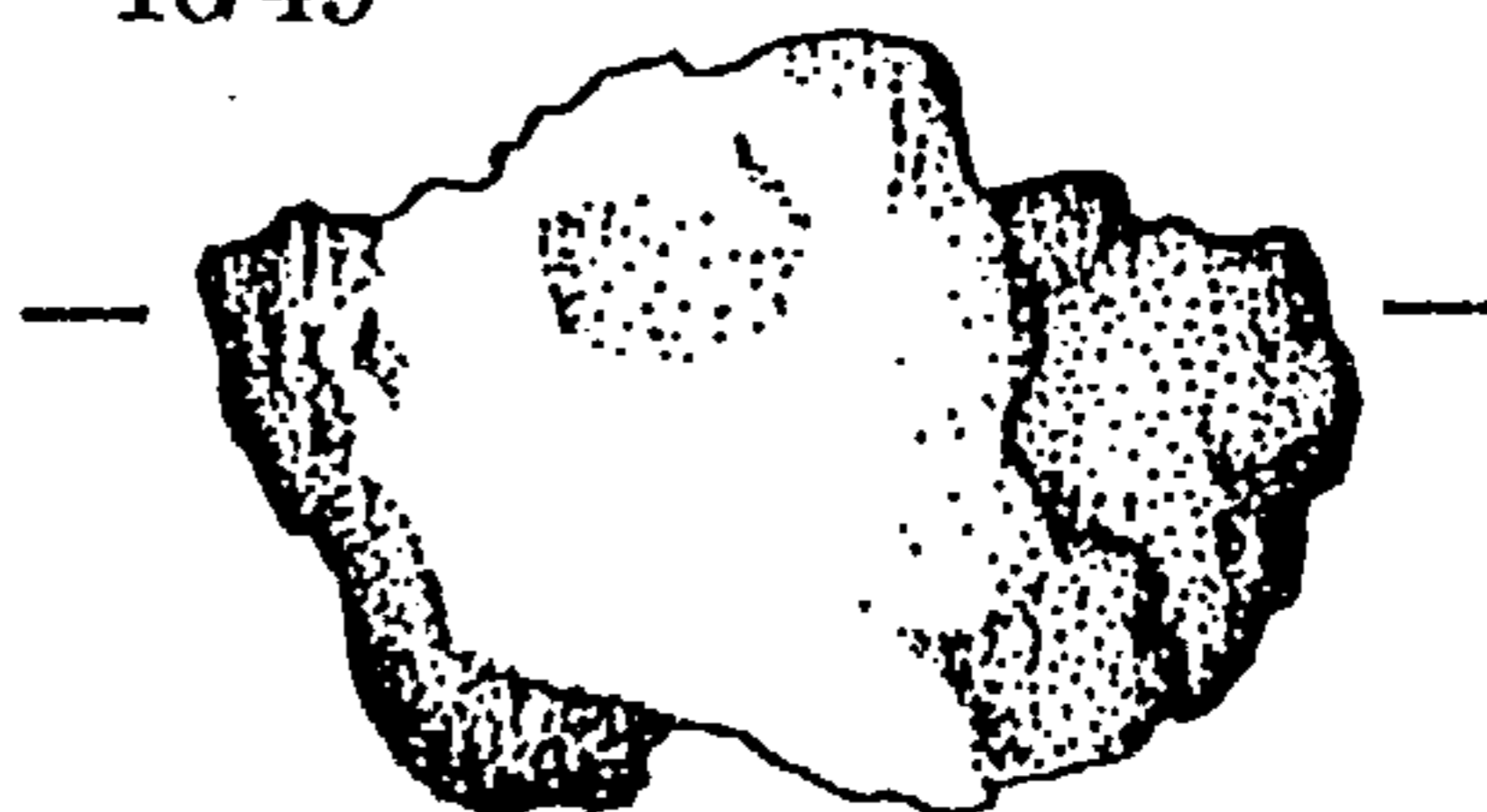


0 2cm

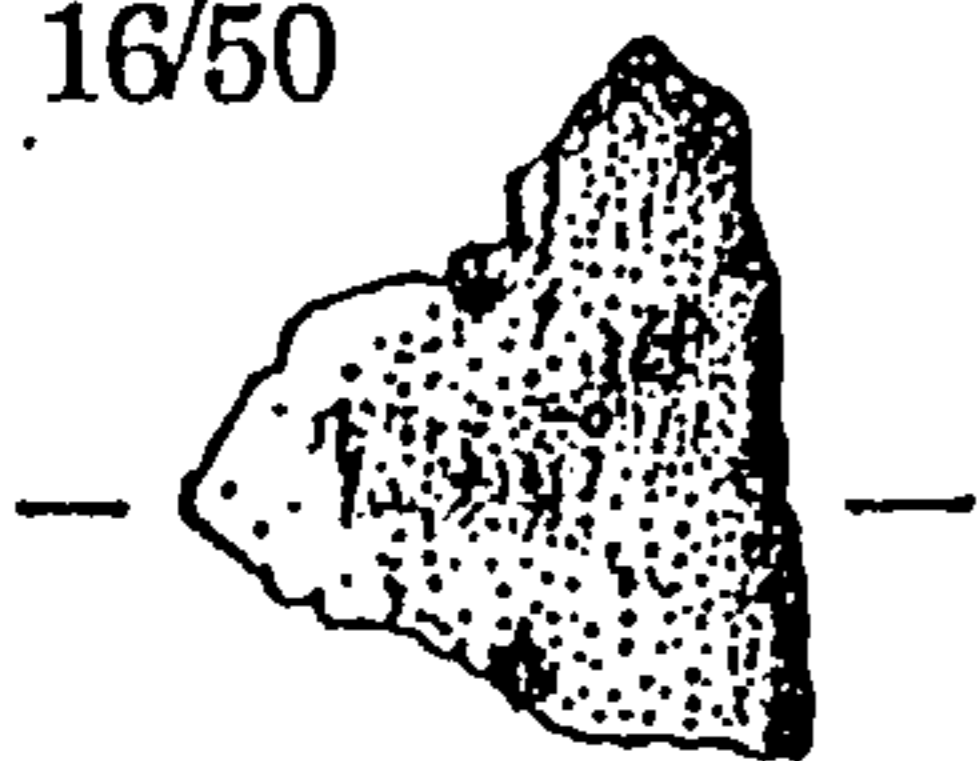
16/48



16/49



16/50



16/51



16/52

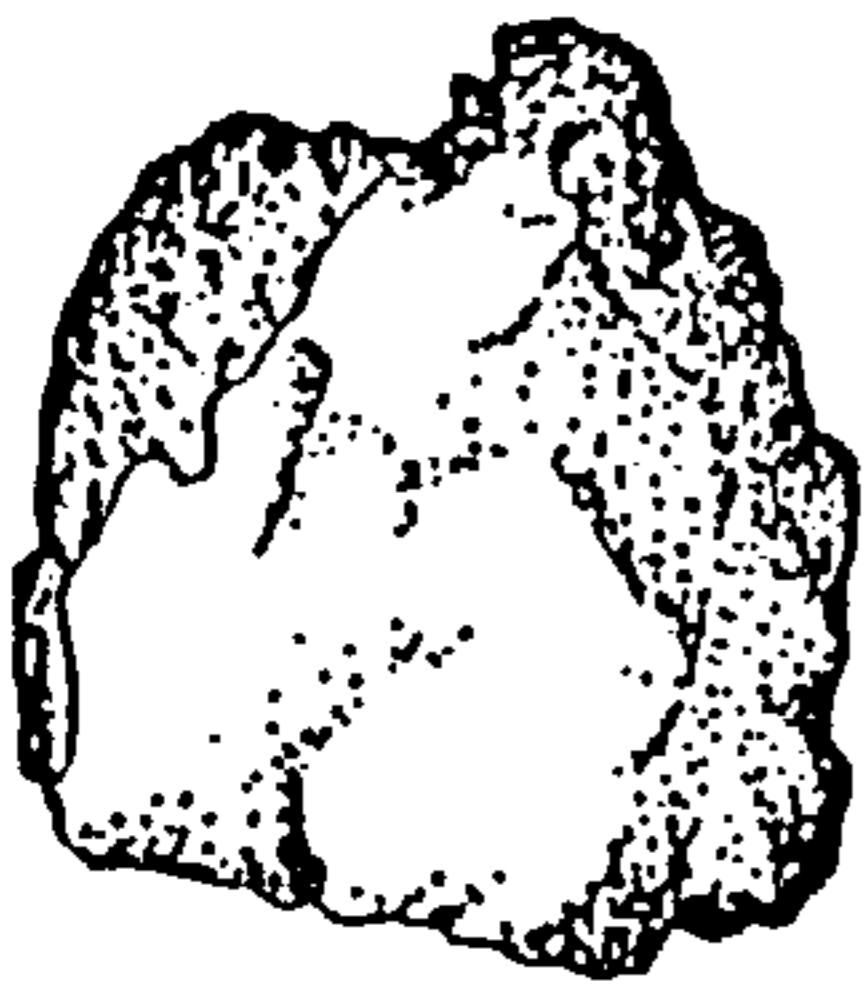


16/53

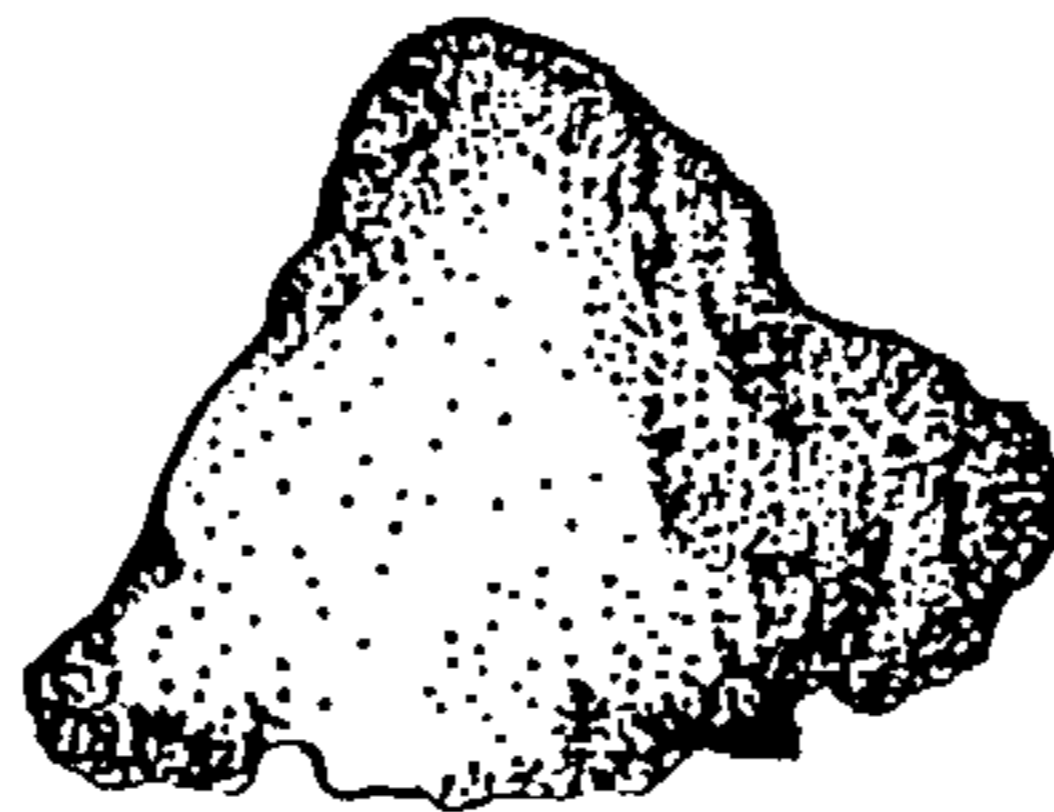


Fig. 32 The Borstal Hoard (Ref. No. 16): Ingot Metal (ii)

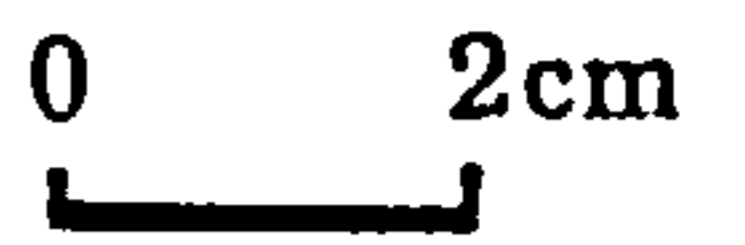
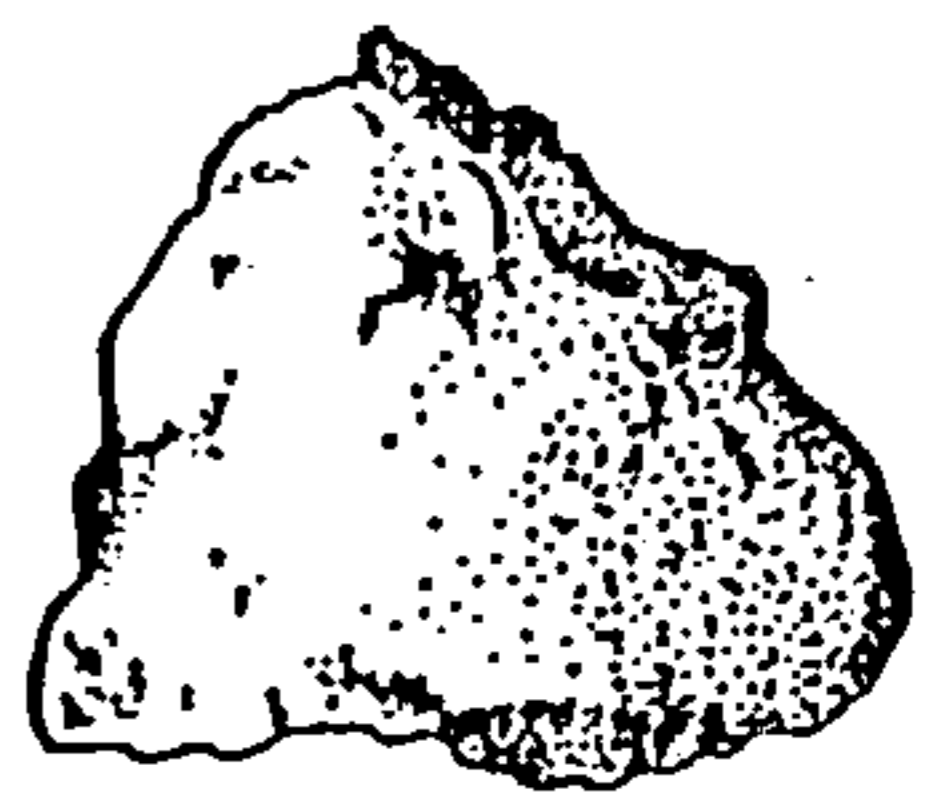
16/54



16/55



16/56



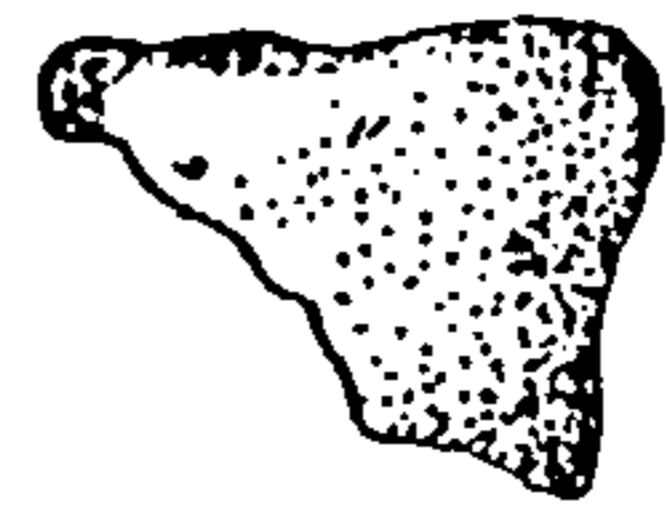
16/57



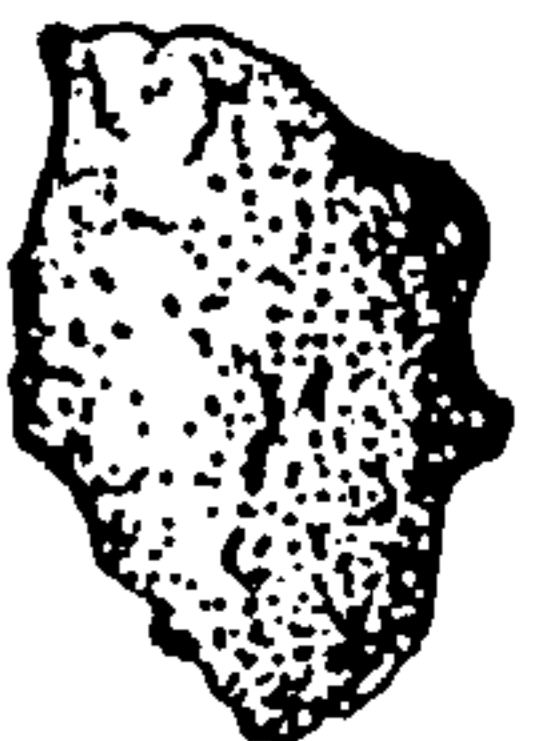
16/58



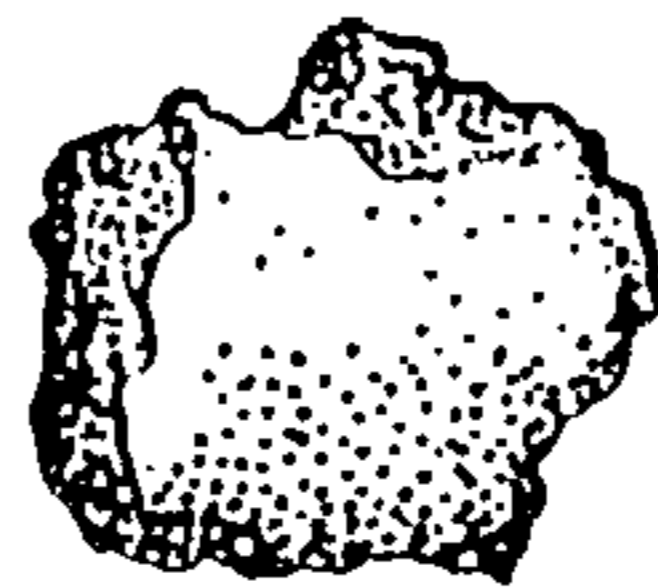
16/59



16/63



16/62



16/61



16/60



16/64



16/65



16/66



Fig. 33 The Borstal Hoard (Ref. No. 16): Ingot Metal (iii)

Cliffe-at-Hoo (Ref. No. 17)

Grid Reference: TQ 725 764.

Current Location: British Museum (Acc. Nos. 1903: 7-23: 2-9). There is considerable doubt as to whether this hoard survives in its entirety. No object numbered 1903: 7-23: 1 is present, and there is a discrepancy between the objects listed in the NBI and those present in the museum collection. The NBI refers to 3 socketed axes, and 2 socketed axe fragments, whereas the hoard consists of 2 socketed axes and 3 socketed axe fragments. No further information is available which can clarify this situation.

Context: No information given.

Bibliography: Jessup, 1930.
National Bronze Index.

Contents:

17/01 (Acc. No. 1903: 7-23: 2)

Description: Socketed axe, of faceted type.

Dimensions: Length: 105mm. Cutting edge: 53mm. Weight: 189.3g.

Patina: Dusty pale green, though with a polished appearance in places. Details poor.

Manufacture: The mouth is uneven, and it is possible that the core was misaligned. The feeders and their intervening seam have been removed from the mouth. On the body, the upper seam is well-finished, though a vestigial trace survives. The lower seam is similar, though it has been retained over the loop. Here, it is thick in appearance, having been flattened. The blade has a crescentic appearance.

Use: The cutting edge is blunt and chipped in places, though it remains intact over its extent.

Reduction: Marked depressions on either side of the lower body were probably inflicted during the removal of a tightly wedged haft.

17/02 (Acc. No. 1903: 7-23: 3)

Description: Socketed axe, of faceted type.

Dimensions: Length: 102mm. Cutting edge: 57mm. Weight: 179.7g.

Patina: Dusty, pale grey-green, details poor.

Manufacture: The mouth has been immaculately finished, with no indications of either feeders or seam remaining. The upper seam has been obliterated over the body, while the lower seam virtually absent, with only a slight step in section marking its course. It remains thick over the loop, where it has been flattened, and retained as a decorative feature. Horizontal grinding marks can be seen over the cutting edge, which is crescentic in appearance.

Use: The cutting edge is chipped and blunted along its length, with one large notch apparent.

Reduction: The object is complete, with no evidence pertaining to this process.

17/03 (Acc. No. 1903: 7-23: 4)

Description: Upper body fragment of 'south-eastern' type socketed axe. On one face two ribs are clearly visible, one near either edge, with a third central rib virtually obscured by corrosion product (illustrated). On the other, the rib nearest the loop is almost invisible.

Dimensions: Length (maximum): 71mm. Weight: 118.8g.

Patina: Dense olive in most places, with patches of pale greyish green and white obscuring the collar in places.

Manufacture: One major casting flaw is visible beneath the loop, and cracks run upwards from this towards the collar. There is another smaller hole near the lower break. There are also indications of core misalignment, with one wall appearing markedly thinner at the lower break, and the mouth having an uneven appearance. The seams and feeders seem to have been completely removed around the mouth. Elsewhere, the upper seam appears to have been trimmed, but no indications of flattening or grinding are apparent. The lower seam is similar, but has been flattened over the loop.

Use: The cracking which runs from the uppermost flaw could be use-related (see below).

Reduction: The cracking around the mouth may result from this stage of the object's use-cycle. There are marked depressions on either face, though they appear worse on the thinner wall. Some of the distortion apparent in the vicinity of the lowermost casting flaw could also

Dimensions: Length (maximum): 80mm. Cutting edge: 40mm. Weight: 160.2g.

Patina: Rough grey-green, details poor.

Manufacture: One wall appears thinner, suggesting core misalignment. The seams on both sides survive in vestigial form, and some traces of the seam appear to have survived over the cutting edge, which is narrow in shape. The presence of this seam along the blade edge should be viewed with caution, though, as these traces may be no more than uneven corrosion product.

Use: No evidence can be linked with this stage of the object's life, and the axehead may never have been used.

Reduction: The object shows extensive deformation on either face, and a considerable number of hammer indents can be seen in association with this. Some small tool marks are also apparent on the interface between one face and its adjoining surface (illustrated).

17/05 (Acc. No. 1903: 7-23: 6)

Description: Lower body and blade of socketed axe.

Dimensions: Length (maximum): 74mm. Cutting edge: 39mm. Weight: 124.3g.

Patina: Rough grey-green, with no details visible.

Manufacture: One wall seems thin, indicating a misaligned core. There are no traces of a seam surviving on either side. The blade appears narrow in shape, though the object has apparently been subject to use.

Use: The blade is blunt and chipped, with notches apparent near one corner.

Reduction: One face has broken away, just above the point where the blade becomes solid in section. On the other face, indentations can be seen in the casting at various points, including one marked example which appears to have resulted from a single hammer blow, and which has led to localised crushing and distortion.

17/06 (Acc. No. 1903: 7-23: 8)

Description: Socketed gouge.

Dimensions: Length: 75mm. Blade width: 15mm. Weight: 43.4g

Patina: Rough grey-green. Some encrustation evident, details obscured.

Manufacture: The mouth seems rough and uneven. On one side of the piece, the seam survives, running right to the blade edge, though it may appear exaggerated due to the nature of the corrosion product. It is less apparent closer to the mouth. On the other it is not so evident, appearing flatter though still remaining in vestigial form.

Use: A slight notch is missing from one corner of the blade edge, and a piece has been broken out of the collar. This could have resulted from use-related damage, though it may have occurred when the haft was removed.

Reduction: A single hammer indent near the collar may be associated with the removal of the haft or handle.

17/07 (Acc. No. 1903: 7-23: 7)

Description: Fragment of 'Ewart Park' sword blade.

Dimensions: Length (maximum): 79mm. Weight: 83.0g

Patina: One side is dense olive, with excellent detail visible. The other side is more patchy in appearance.

Manufacture: Bevels can be seen on either cutting edge. Some vertical grinding marks are visible on blade and bevel, and the surface has been finely hammered.

Use: The edges seem quite blunt, one side having a rather chipped appearance.

Reduction: The profile appears faintly distorted, with some hammering apparent on the midrib near either break.

17/08 (Acc. No. 1903: 7-23: 9)

Description: Undecorated leaf-shaped socketed spearhead, with 2 rivet holes present in the socket.

Dimensions: Length: 118mm. Weight: 54.3 g.

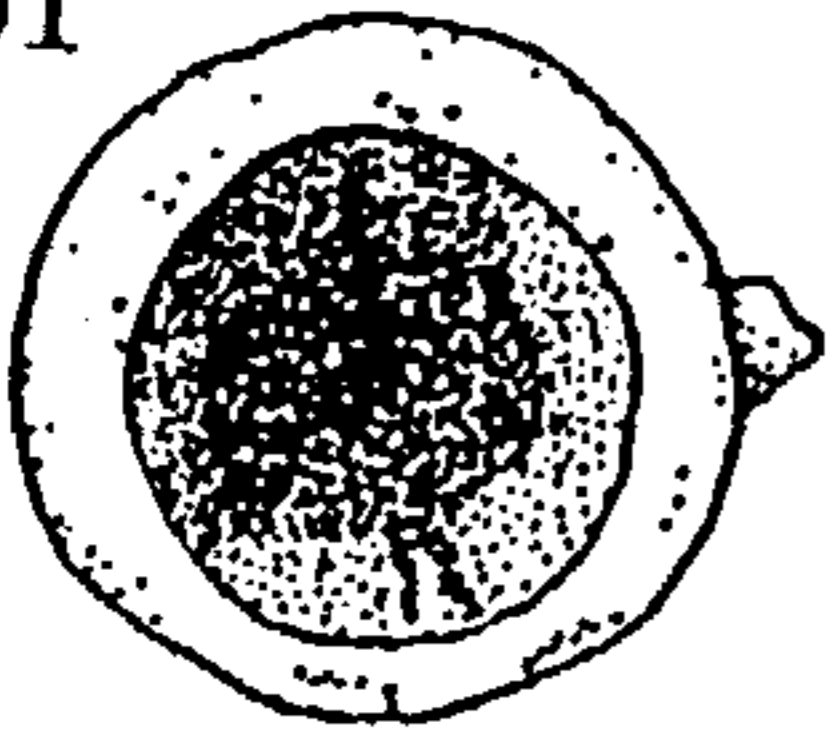
Patina: Some glossy dark bronze patches remain, with stretches of brown, pale-green and greyish-pink corrosion products elsewhere. Details are locally good.

Manufacture: The seams have been removed on the sides and around the mouth of the socket. No traces of any grinding marks are visible, and the blade edges are bevelled.

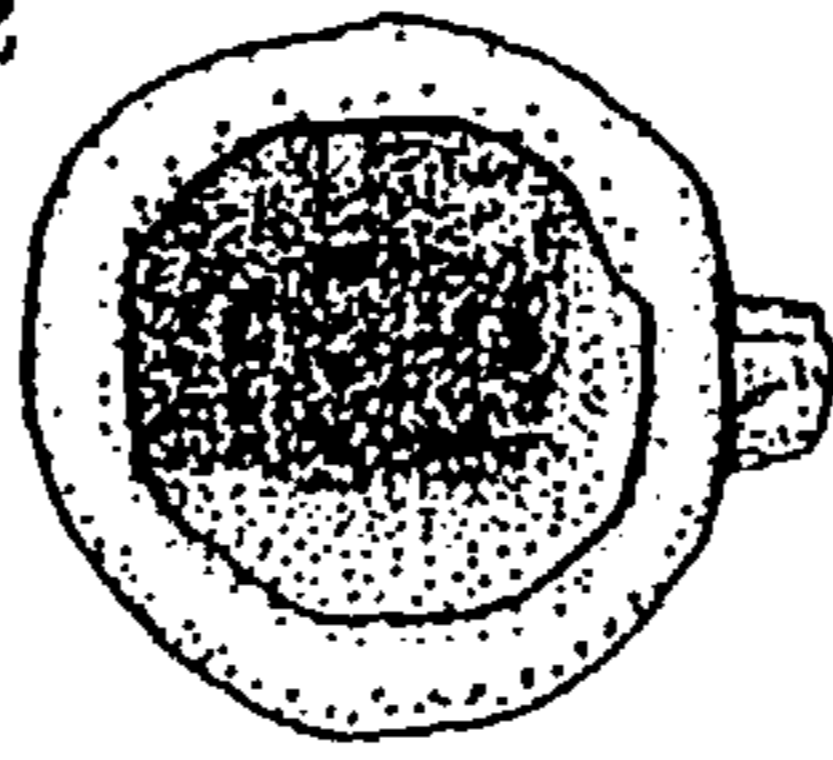
Use: One rivet hole seems enlarged, as if strained through use. The blade edges appear chipped and blunted along their length, though this damage may be exaggerated by corrosion build-up.

Reduction: Some hammer indents are visible on the socket, though no major distortion is apparent in association with these.

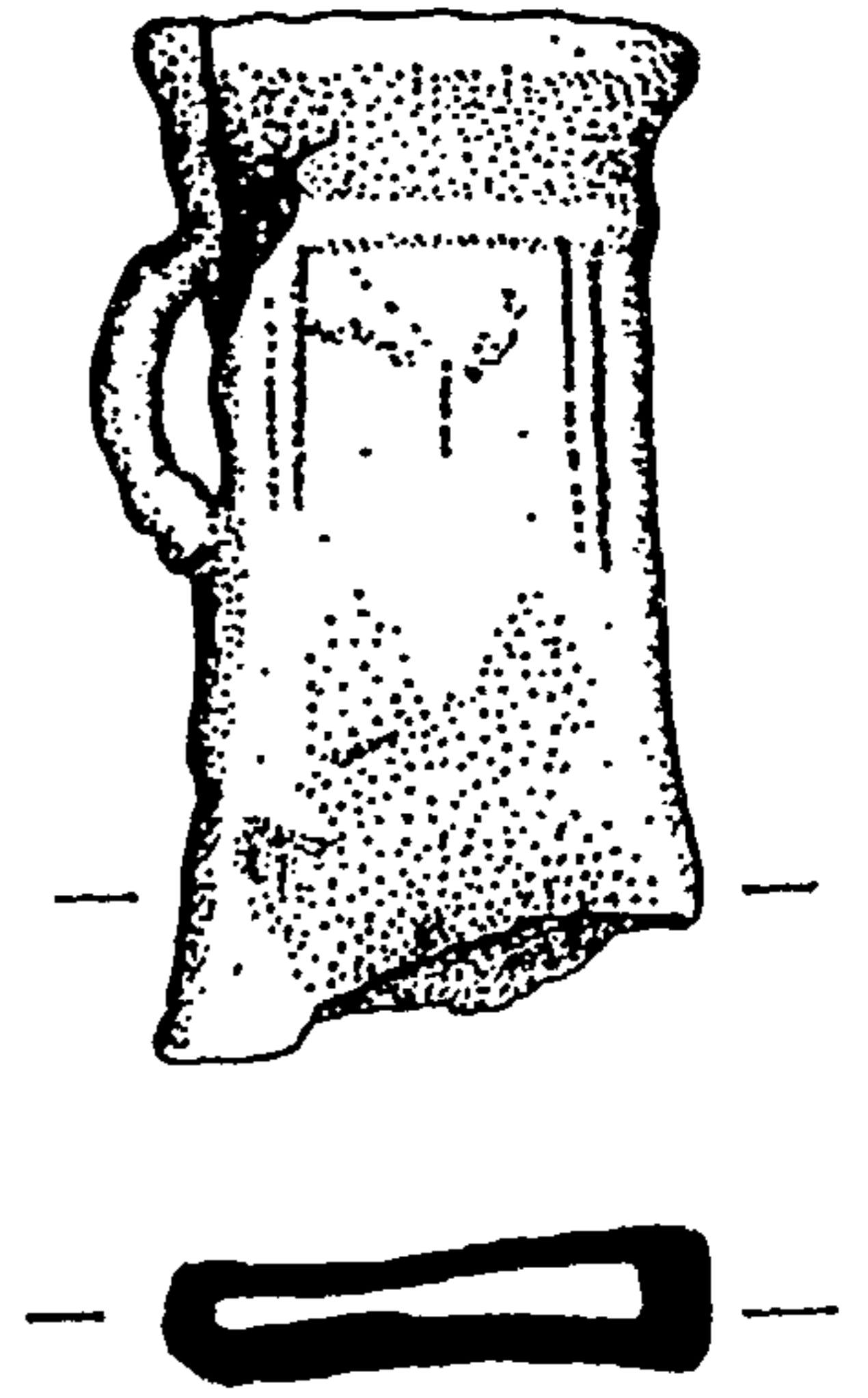
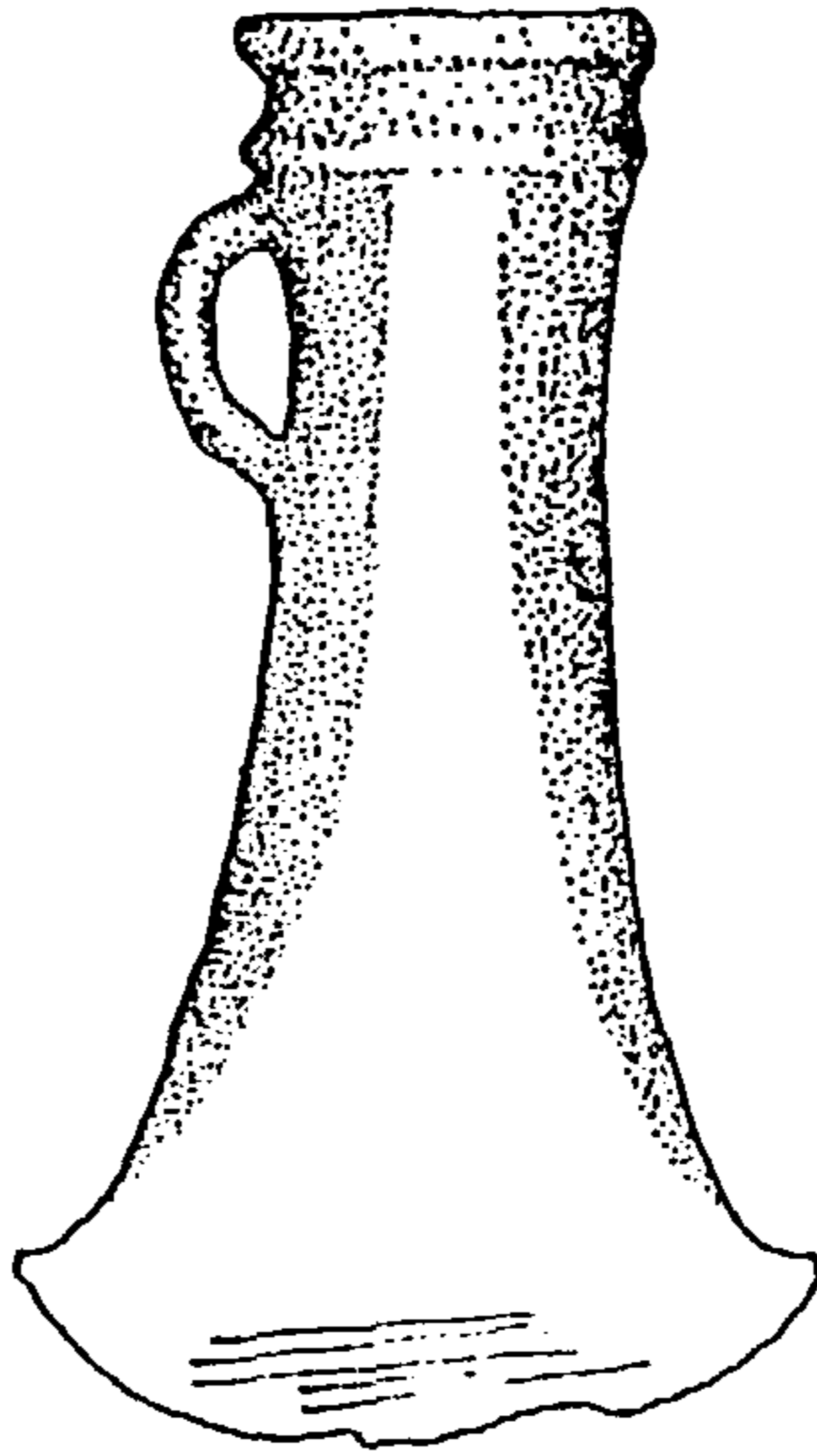
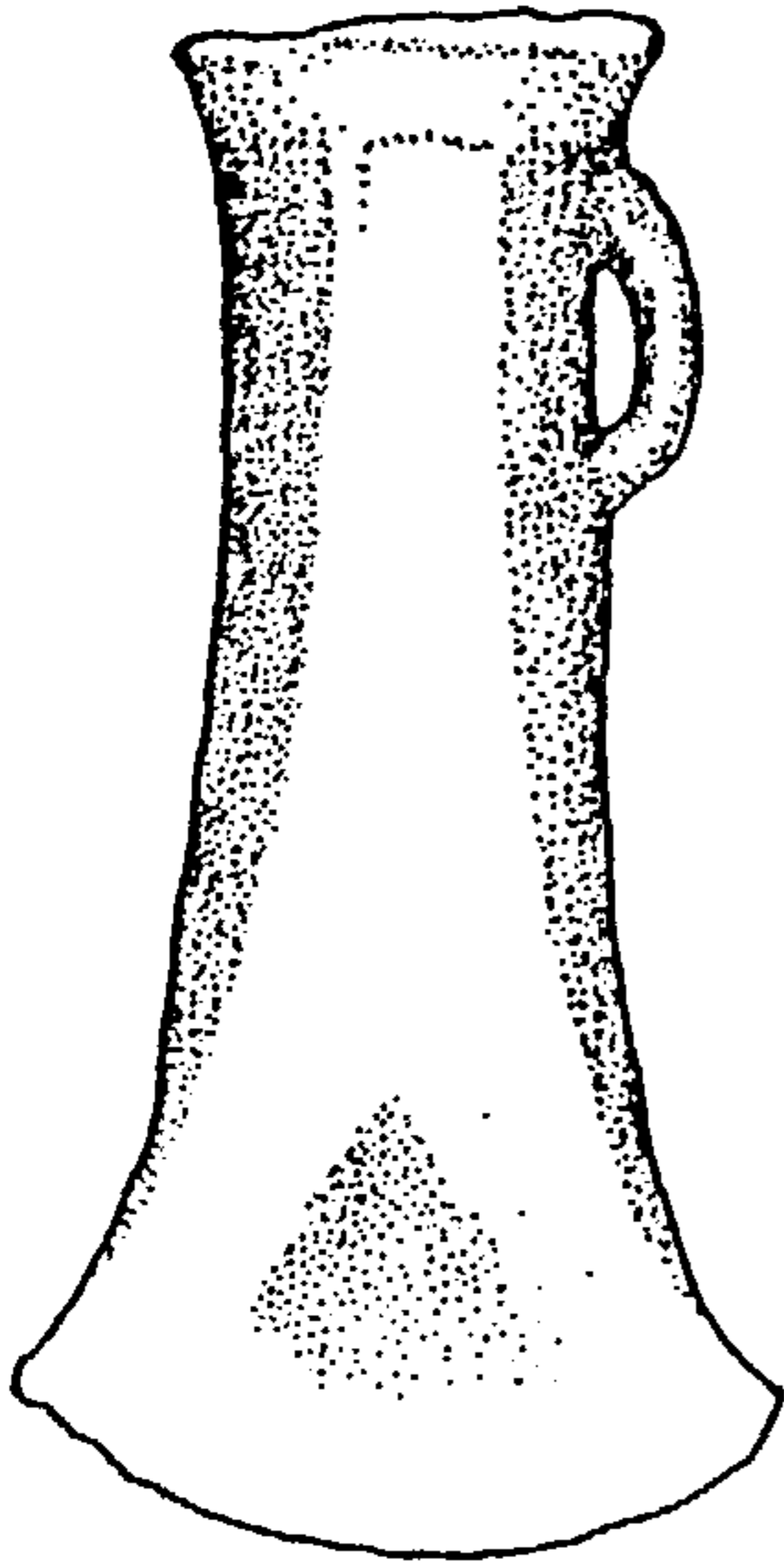
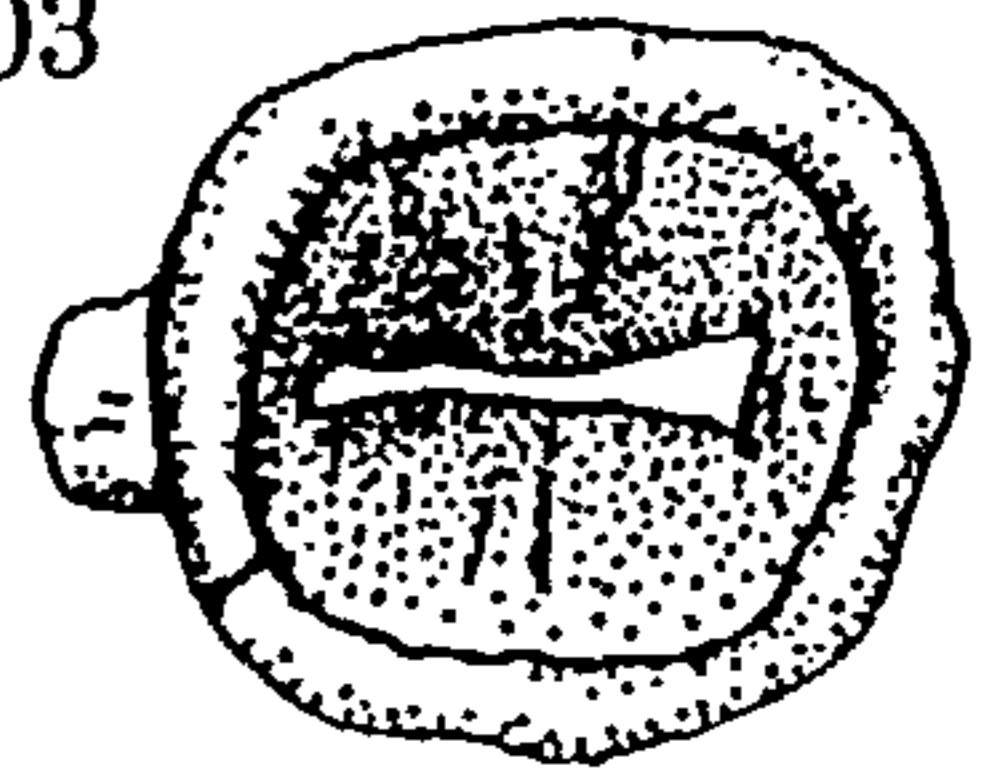
17/01



17/02



17/03



17/06

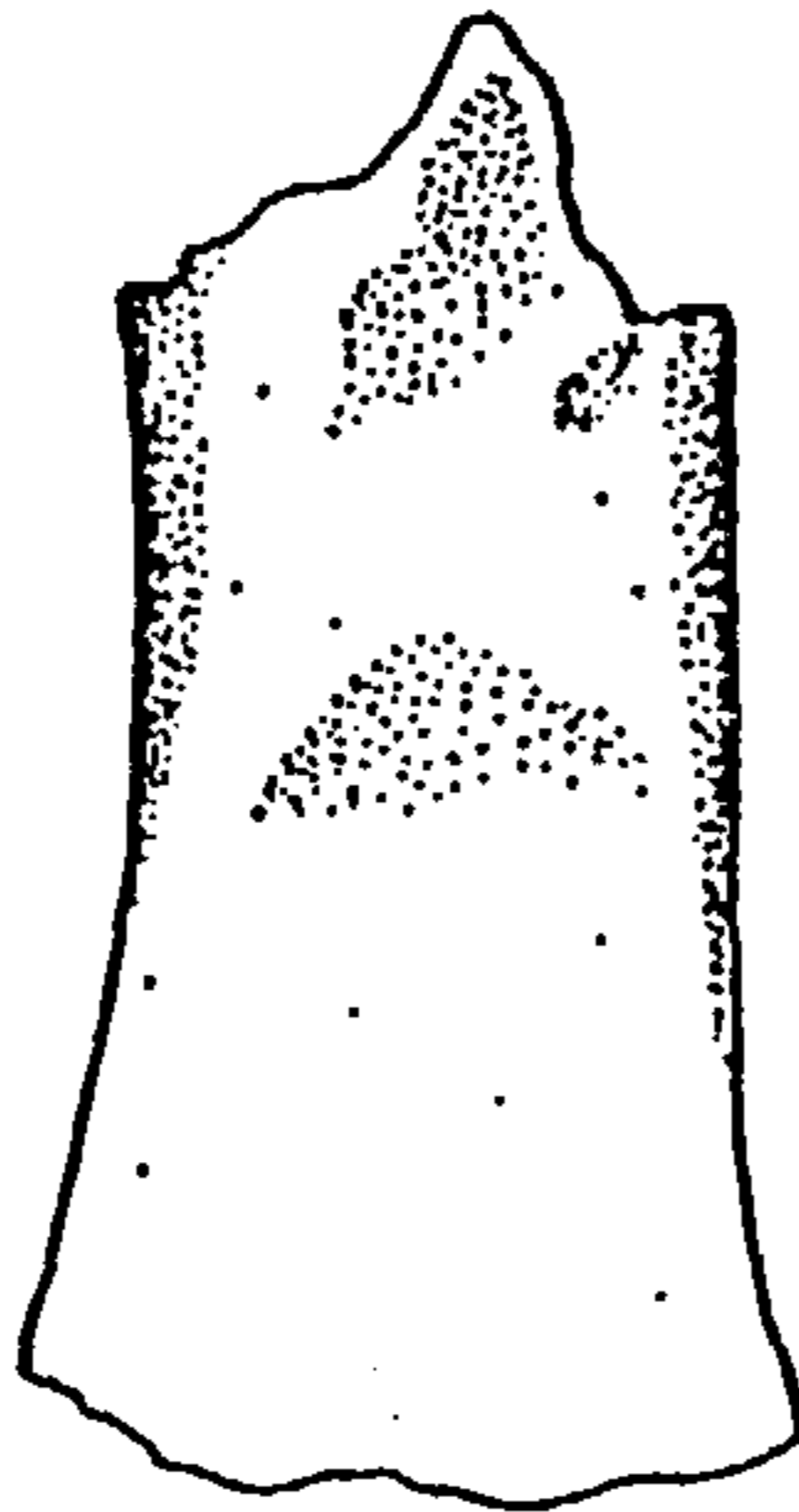


0 2cm

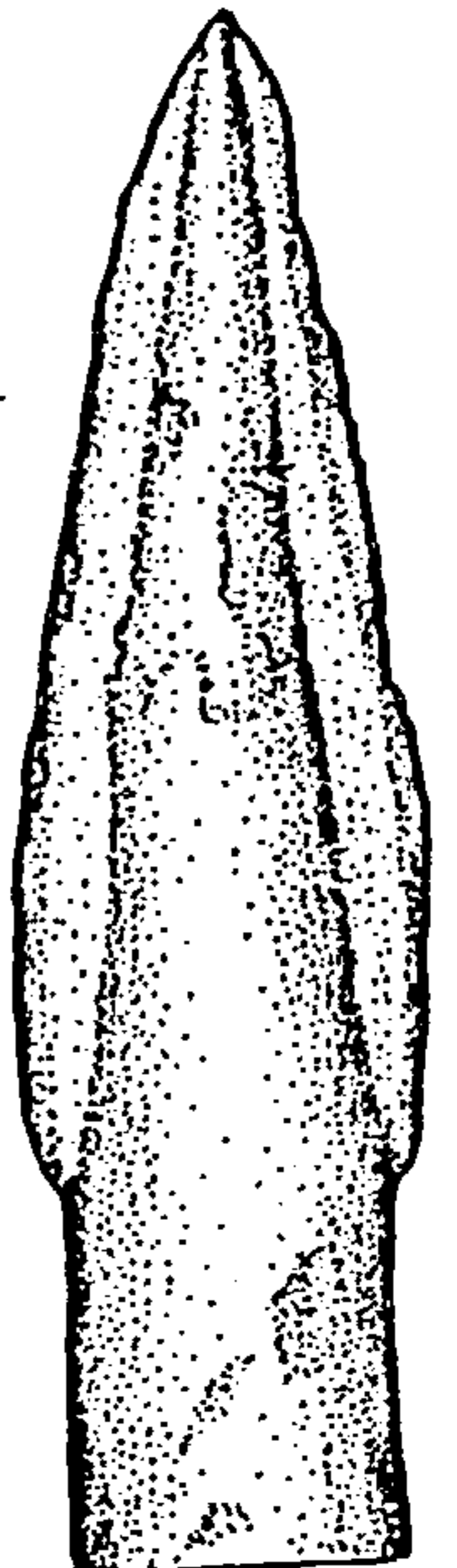
17/04



17/05



17/08



17/07

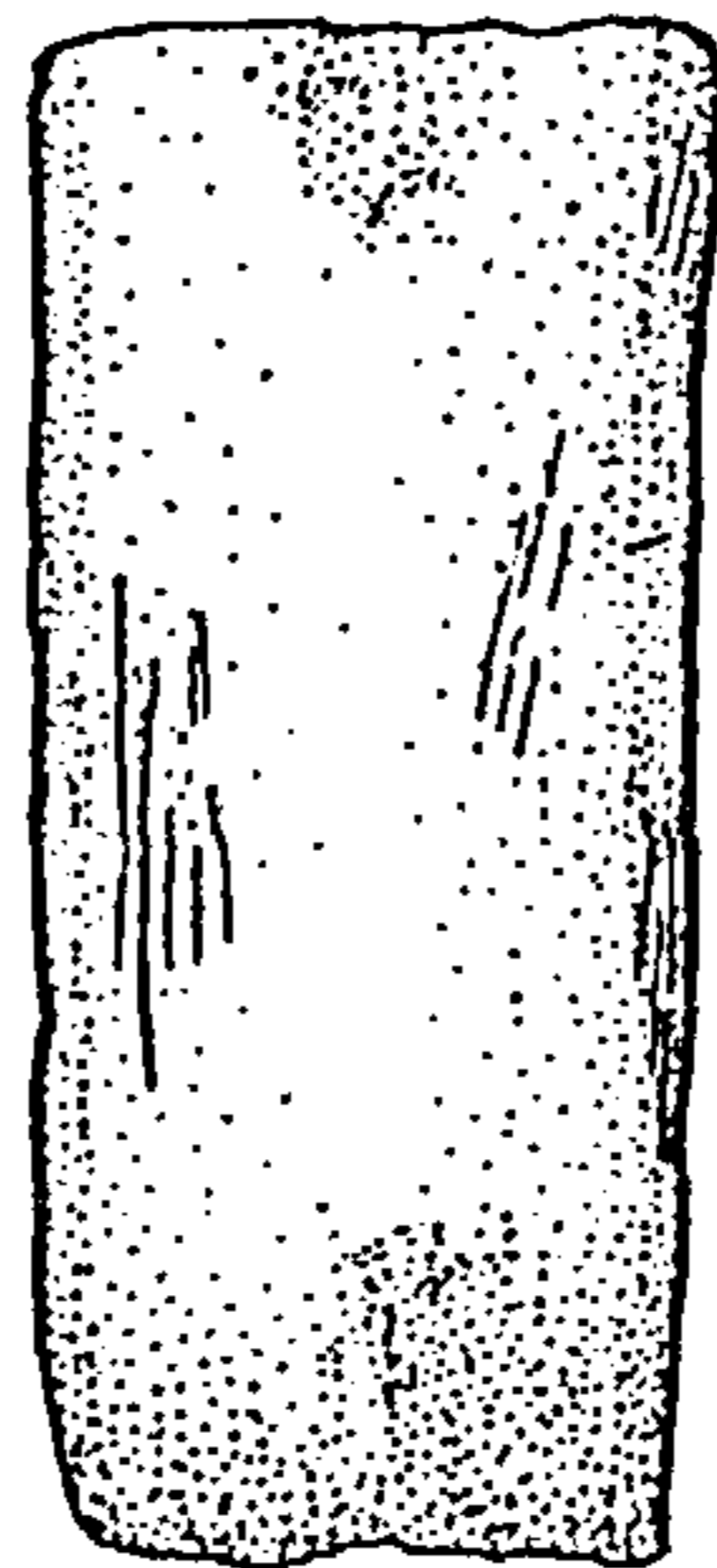


Fig. 34 The Cliffe-at-Hoo Hoard (Ref. No. 17)

Dartford (Ref. No. 18)

Grid Reference: TQ 525 744.

Current Location: British Museum, Accession Numbers 1946: 7-6: 1-33.

Context: Only limited information is available regarding the hoard's context. Burgess and Colquhoun state that the hoard was found during the course of constructing a road near Watling Street (Burgess and Colquhoun, 1988).

Bibliography: Brailford, 1947.
Burgess and Colquhoun, 1988.
National Bronze Index.

Contents:-

18/01 (Acc. No. 1946: 7-6: 1)

Description: Socketed axe of 'southern English' type, with 9 ribs visible on one face, and 8 on the other.

Dimensions: Length: 105mm. Cutting edge: 55mm. Weight: Unknown.

Patina: Dense olive, details reasonable.

Manufacture: Two casting flaws are apparent. One comprises a small, though substantial, hole adjacent to the loop, with another tiny hole occurring roughly halfway down the upper surface. The mouth seems uneven, with traces of both the feeders and the intervening seam still apparent. Over the body, the uppermost seam has been trimmed and roughly flattened over its extent, but it remains prominent down to the cutting edge. The underside is similar, though the seam is flatter over the loop and may have been ground and polished here. Diagonal grinding marks are apparent in some places. Some, located on the interfaces between the face and the upper and lower surfaces on one side (not illustrated) are associated with patches of fresh bronze and may have resulted from recent damage. Others occurred in antiquity, including some on the lower body of one face (illustrated), and horizontal grinding marks are visible over the cutting edge. The blade has a crescentic appearance.

Use: The cutting edge appears broken along its length. Some damage has resulted from later loss of the corrosion product, though some probably occurred through use.

Reduction: The object is complete and there is no evidence relating to this process.

18/02 (Acc. No. 1946: 7-6: 2)

Description: Socketed axe of 'south-eastern' type, bearing an unusual variant on the wing-decorated form. Here, short ribs run between both wings, though this decoration is only vaguely apparent on one side and is almost invisible on the other. There are 2 prominent ribs on the interior.

Dimensions: Length: 95mm. Cutting edge: 47mm. Weight: 237.4g.

Patina: Dense dark green, with pale green encrustation in places. Details locally good.

Manufacture: The mouth appears uneven, suggesting an inadequate supply of metal during casting, and both the feeders and the intervening seam appear to be well-finished here. The upper seam has been trimmed and polished over the body, but remains visible to a point which lies a third of the way down towards the cutting edge. The lower seam is similar, though it has been obliterated over the loop, and there is evidence of hammering in association with this. Fine hammering is also evident on the lower body, and it seems likely that this is related to the finishing process. Horizontal grinding marks are present over the cutting edge, which is crescentic in appearance.

Use: The cutting edge is chipped over its extent, and is badly burred in one place.

Reduction: Small tool marks are visible on the mouth, which may relate to the removal of the haft.

18/03 (Acc. No. 1946: 7-6: 5)

Descriptions: Small socketed axe, with plain blade and single collar moulding.

Dimensions: Length: 55mm. Cutting edge: 38mm. Weight: 58.6g.

Patina: Dense olive, with some rough patches around the collar. Details reasonable.

Manufacture: The mouth is slightly uneven but is well-finished, with only vestigial traces of the lowermost feeder remaining. The loop seems unusually thin in this example. Over the body, the upper seam remains prominent. Though it seems to have been trimmed, hammered and polished over its length, it remains visible right down to the cutting edge. The underside is similar, though the piece has been very well-finished over the loop. The cutting edge is crescentic in appearance.

Use: The breakage may be use-related. Much of one face is now missing, to the point where the body joins the blade. A hairline crack runs down the other face, suggesting similar damage, the outcome of which has been less severe. The blade is very uneven, suggesting resharpener. It is notched and chipped along its length, with an extensive amount of damage apparent along the edge of the side not illustrated (fig. 5).

Fig. 5



Reduction: A cluster of chisel marks are visible on the surviving face. These could have been inflicted during the cutting of the material which bound the axehead to the haft.

18/04 (Acc. No. 1946: 7-6:3)

Description: Mouth and upper body of socketed axe, with one flared single moulding around the mouth. 3 ribs run down either face.

Dimensions: Length (maximum): 84mm. Weight: 159.5g.

Patina: Rough olive green, with patches of pale green encrustation in places.

Manufacture: There are no clear indications of any casting flaws, though the loop seems thin and slightly misshapen. The mouth seems rough, but the seams have been removed, and the feeders have been removed and flattened, too, surviving only as vestigial traces. Where the body survives, the seams remain prominent but smooth, and are visible right down to the break. The seam has been virtually obliterated over the loop, however.

Use: Impossible to determine.

Reduction: Hammering has created a slight depression above the break on one face, and this has flattened the central rib. Mild crushing of the section is apparent, and this appears more marked in association with the depression noted above.

18/05 (Acc. No. 1946: 7-6: 4)

Description: Mouth and upper body of 'southern English' type socketed axe, with 6 ribs visible on one face, and 5 on the other. There is also an unusual ribbed effect elsewhere on the lower faces and other surfaces.

Dimensions: Length (maximum): 77mm. Weight: 226.5g.

Patina: Dense dark green, with some dusty brownish patches. Details poor.

Manufacture: The mouth seems very rough and uneven, with much of the top collar missing as a result of an inadequate supply of metal during casting. The rounded stump of one feeder remains here, though no traces of the other survive elsewhere due to the chronic lack of metal. On the body, the top seam has been hammered flat, but prominent traces remain until c.50mm from the break. The lower seam is similar, and remains prominent over the loop, with a massive lump - possibly a chaplet - apparent here close to the collar.

Use: Impossible to determine.

Reduction: There is no evidence relating to this process.

18/06 (Acc. No. 1946: 7-6: 6)

Description: Mouth and upper body of undecorated 'south-eastern' type socketed axe.

Dimensions: Length (maximum): 69mm. Weight: 105.1g.

Patina: Rough mid-green. Details poor.

Manufacture: One wall is thinner, indicating core misalignment. The mouth is well-finished, with the feeders and their intervening seam removed. Over the body, the seams are apparent in vestigial form - though remaining thick, they have been well flattened. No traces of the seam survive over the loop, though corrosion products obscure the piece here.

Use: Impossible to determine.

Reduction: Both faces show evidence of hammering near the mouth and near the lower break. The piece has been crushed along a line running down the centre of both faces, with each individual face displaying different characteristics. In the first (illustrated), the mouth has been crushed and the lower collar moulding flattened so that it is now barely discernible. A depression runs the entire length of this face, with a larger, more extensive depression apparent near the lower break. Similar damage has been inflicted on the other face (not illustrated), causing cracking which has resulted in the loss of much of the lower body here. In the vicinity of this break, the metal shows evidence of crushing. Altogether, the axe is much distorted.

18/07 (Acc. No. 1946: 7-6:8)

Description: Blade fragment from socketed axe, or possibly adze. It seems highly likely that this piece is an axehead which is now much distorted. The hollow section implies that it is unlikely to be a winged axe, though hollow-sectioned winged axes are not unknown (e.g. All Hallows I, 12/17). Its thin shape and section might support the winged axe/adze theory, though.

Dimensions: Length (maximum): 79mm. Cutting edge: 35mm. Weight: 76.9g.

Patina: Rough grey-green, with some bronze patches remaining. Details locally reasonable.

Manufacture: The casting seams are still apparent as vestigial traces on both sides, to a point c.15mm above the blade. Horizontal grinding marks are visible over the cutting edge on one side (illustrated). The casting seems rather insubstantial, suggesting core misalignment, and the blade does not show signs of having been much expanded.

Use: The blade appears chipped and broken along its length, with the original cutting edge surviving along only a small part of its extent.

Reduction: Both faces show indications of hammering. One (not illustrated) shows only faint distortion, with one hammer mark visible at the point where body and blade edge merge. The other (illustrated) shows marked crushing of the metal, associated with cracking and breakage, and now much of the face is now missing. There is a marked kink apparent in the object's profile, and this is likely to have resulted from hammering. Clay or soil adheres to the base of the socket.

18/08 (Acc. No. 1946: 7-6: 10)

Description: Blade fragment of socketed axe.

Dimensions: Length (maximum): 39mm. Cutting edge: 52mm. Weight: 78.5g.

Patina: Dense olive green, details poor.

Manufacture: Both walls seem to be of uniform thickness. The seams remain thick, and although they appear to have been largely removed from either side, they leave a prominent trace, though this has been flattened and ground. The blade is crescentic in appearance.

Use: Slight chipping is evident along the length of the cutting edge, but it remains reasonably fine. It has probably been resharpened.

Reduction: There is a slight depression located just beneath the break on one face (illustrated). On the other, three substantial hammer indents are apparent on the blade, just above the cutting edge, but these may have been inflicted during manufacture or resharpening.

18/09 (Acc. No. 1946: 7-6: 11)

Description: Blade fragment of hollow-sectioned axehead. It bears the triangular depression usually associated with winged axes, but closer examination suggests that this might be a fortuitous result of subsequent hammering.

Dimensions: Length (maximum): 37mm. Width: 24mm. Weight: 50.2g.

Patina: Thick mid-green, details poor.

Manufacture: There are no visible indications of any casting seams remaining. The blade is fairly well-expanded, though the rounded appearance of a large notch which is present in the cutting edge suggests that it resulted - at least in part - from a casting flaw.

Use: Where it remains intact, the cutting edge is very blunt. Since a casting flaw appears to have been present here, it is likely that the axehead would not have functioned particularly well, and the blunt nature of the blade might indicate that it was never actually

used. The edge seems rough, however, and this and the well-finished appearance of the object suggests that it was indeed completed and subject to use.

Reduction: The piece has been hammered inwards on both faces, causing distortion of the section, cracking above the cutting edge (not illustrated) and breakage. Some individual hammer indents can be identified.

18/10 (Acc. No. 1946: 7-6: 9)

Description: Blade fragment of winged axe or adze.

Dimensions: Length (maximum): 65mm. Cutting edge: 42mm. Weight: 157.2g.

Patina: Dense olive, some flaked light green spots in places.

Manufacture: No traces of any casting seams survive. On one side, though, the patina obscures the details and may hide the seam, but it seems likely that all the seams have been trimmed, flattened and polished to the point of obliteration. The blade is narrow, but is crescentic in appearance.

Use: The blade has probably been subject to resharpening. Much of the cutting edge is now missing, with large notches broken from its length.

Reduction: The adze-like bend in the piece may result from hammering, but there are no clear indications of this. Instead, all visible hammer indents result from the fine working required to finish the piece. There are no traces of hammering near the upper break, either.

18/11 (Acc. No. 1946: 7-6: 7)

Description: Fragment of late palstave, comprising blade and base of septum. Two triangular indentations run from the septum, and part of the loop survives.

Dimensions: Length (maximum): 66mm. Weight: 227.4g.

Manufacture: Traces of the seam still remain visible, though these have been smoothed down well. The seam is less apparent on the underside, where only vestigial traces remain. Hammering on the blade may be related to manufacture.

Use: Impossible to determine.

Reduction: The butt and the cutting edge are missing, but there are no visible indications, i.e. hammer indents, which indicate how this breakage took place.

18/12 (Acc. No. 1946: 7-6: 13)

Description: Roughly half of a knobbed sickle, comprising the butt and part of the blade.

Dimensions: Length (maximum): 87mm. Weight: 59.3g.

Patina: Rough grey-green, some bronze showing.

Manufacture: One face shows numerous holes and a few larger fissures, indicating a poor casting, possibly caused by a wet mould. Numerous horizontal and diagonal grinding marks are visible on this side (not illustrated), and there are no indications of any casting seams. A bevel runs along the cutting edge.

Use: The blade seems very blunt, and is notched in places near either break.

Reduction: There is a marked bend to the profile, with no indications of hammering near the break. The piece may have been snapped into pieces rather than fragmented through hammering.

18/13 (Acc. No. 1946: 7-6: 12)

Description: Hilt and shoulders of socketed sword. Two rivet holes are apparent, one with a rivet in situ, and there may be a third rivet hole surviving in vestigial form.

Dimensions: Length (maximum): 63mm. Weight: 110.4g.

Patina: Rough mid-green with some glossy green patches. Details fair.

Manufacture: Hammering is apparent on the interface between the hilt and the blade. There are no traces of any casting seams, the hilt having been beautifully finished, and a fine bevel runs along the surviving length of either cutting edge.

Use: Both cutting edges are chipped along their length, though the condition of one seems worse than the other.

Reduction: There is a faint bend evident in the profile of the piece. One hammer indent is visible near the upper break on one side (illustrated). In addition, a cluster of hammer indents can be identified at the lower break on the other (not illustrated). The surviving rivet has been sheared off and fresh bronze has been exposed, suggesting recent damage.

18/14 (Acc. No. 1946: 7-6: 14)

Description: Large piece of copper ingot, comprising roughly a quarter of the original object.

Dimensions: Length: 106mm. Width: 78mm. Thickness: 280mm. Weight: 980.2g.

Observations: Some chisel marks are apparent on one surface (illustrated), but these must remain problematic, as they are associated with an unpatinated area. There are also grinding marks visible in places, once again linked with an absence of patina, and therefore an origin in antiquity cannot be confidently asserted for these, either.

18/15 (Acc. No. 1946: 7-6: 15)

Description: Piece from edge of copper ingot, with voids in the metal.

Dimensions: Length: 95mm. Width: 51mm. Thickness: 27mm. Weight: 431.4g.

18/16 (Acc. No. 1946: 7-6: 16)

Description: Piece from edge of copper ingot, with numerous voids in the metal, some large in size.

Dimensions: Length: 81mm. Width: 49mm. Thickness: 30mm. Weight: 349.9g.

18/17 (Acc. No. 1946: 7-6: 17)

Description: Piece from interior of copper ingot.

Dimensions: Length: 62mm. Width: 56mm. Thickness: 29mm. Weight: 463.1g.

18/18 (Acc. No. 1946: 7-6: 18)

Description: Piece from interior of copper ingot.

Dimensions: Length: 63mm. Width: 35mm. Thickness: 28mm. Weight: 383.4g.

18/19 (Acc. No. 1946: 7-6: 19)

Description: Piece from edge of copper ingot. Numerous voids are apparent in the interior.

Dimensions: Length: 82mm. Width: 46mm. Thickness: 22mm. Weight: 309.9g.

18/20 (Acc. No. 1946: 7-6: 20)

Description: Small piece from edge of copper ingot.

Dimensions: Length: 63mm. Width: 45mm. Thickness: 31mm. Weight: 269.1g.

18/21 (Acc. No. 1946: 7-6: 21)

Description: Small piece from edge of copper ingot.

Dimensions: Length: 61mm. Width: 43mm. Thickness: 24mm. Weight: 250.0g.

18/22 (Acc. No. 1946: 7-6: 22)

Description: Fragment from interior of copper ingot.

Dimensions: Length: 55mm. Width: 37mm. Thickness: 27mm. Weight: 266.0g.

18/23 (Acc. No. 1946: 7-6: 23)

Description: Fragment from edge of copper ingot. The edge seems unusually thick in section.

Dimensions: Length: 51mm. Width: 30mm. Thickness: 27mm. Weight: 245.1g.

Observations: The edge seems very smooth and polished, as one might expect if re-used, for example, as a hammer. However, no burring is associated with the metal here, and so one must remain skeptical of this possibility.

18/24 (Acc. No. 1946: 7-6: 24)

Description: Edge fragment of copper ingot, massive voids present.

Dimensions: Length: 66mm. Width: 43mm. Thickness: 20mm. Weight: 158.9g.

Observations: There is an unusually straight stretch along the edge, but there are no clear indications of re-use.

18/25 (Acc. No. 1946: 7-6: 25)

Description: Small piece of copper ingot, very thin in section.

Dimensions: Length: 56mm. Width: 52mm. Thickness: 10mm. Weight: 130.9g.

18/26 (Acc. No. 1946: 7-6: 26)

Description: Small piece from edge of copper ingot, with voided appearance to interior.

Dimensions: Length: 52mm. Width: 46mm. Thickness: 18mm. Weight: 175.8g.

18/27 (Acc. No. 1946: 7-6: 27)

Description: Small piece from edge of copper ingot, with voids in the interior.

Dimensions: Length: 63mm. Width: 41mm. Thickness: 22mm. Weight: 183.5g.

18/28 (Acc. No. 1946: 7-6: 28)

Description: Small piece from interior of copper ingot, with voids in the interior.

Dimensions: Length: 48mm. Width: 40mm. Thickness: 20mm. Weight: 181.8g.

18/29 (Acc. No. 1946: 7-6: 29)

Description: Small piece of copper ingot, with very large voids present.

Dimensions: Length: 52mm. Width: 35mm. Thickness: 11mm. Weight: 108.1g

18/30 (Acc. No. 1946: 7-6: 30)

Description: Fragment from edge of copper ingot, with large voids present in the interior.

Dimensions: Length: 41mm. Width: 39mm. Thickness: 20mm. Weight: 132.0g.

18/31 (Acc. No. 1946: 7-6: 31)

Description: Fragment from interior of copper ingot, rather thin.

Dimensions: Length: 48mm. Width: 29mm. Thickness: 18mm. Weight: 92.3g.

18/32 (Acc. No. 1946: 7-6: 32)

Description: Fragment from interior of copper ingot.

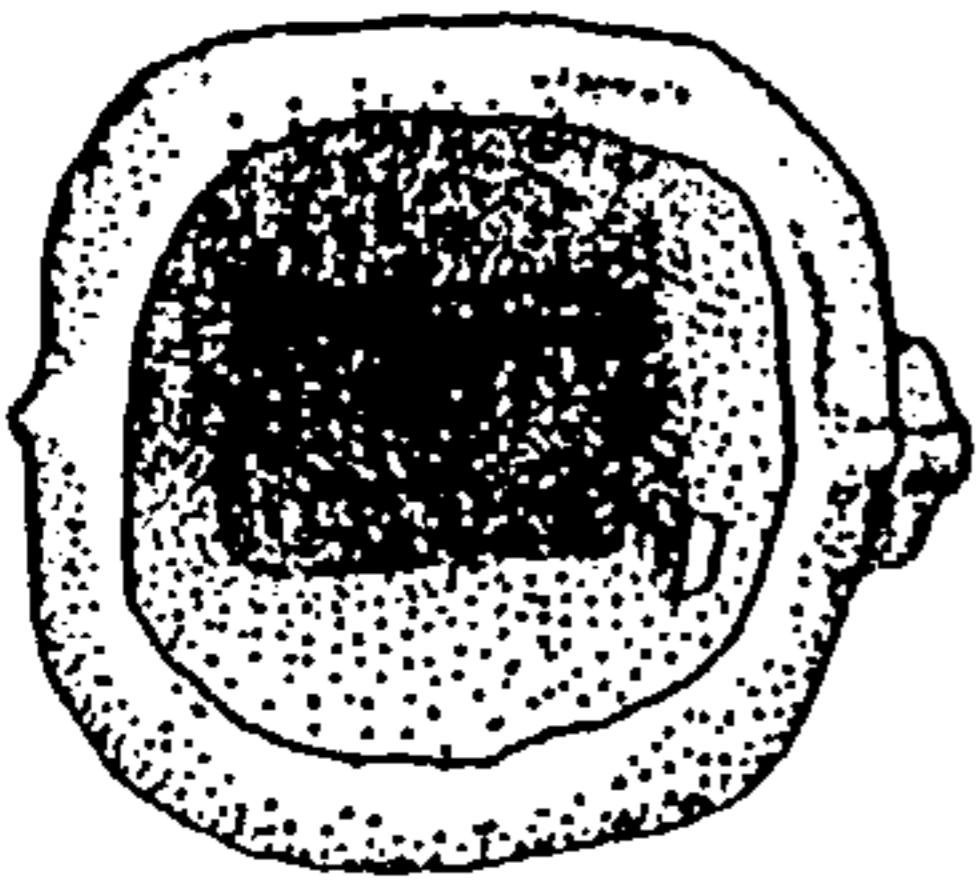
Dimensions: Length: 22mm. Width: 18mm. Thickness: 32mm. Weight: 57.8g.

18/33 (Acc. No. 1946: 7-6: 33)

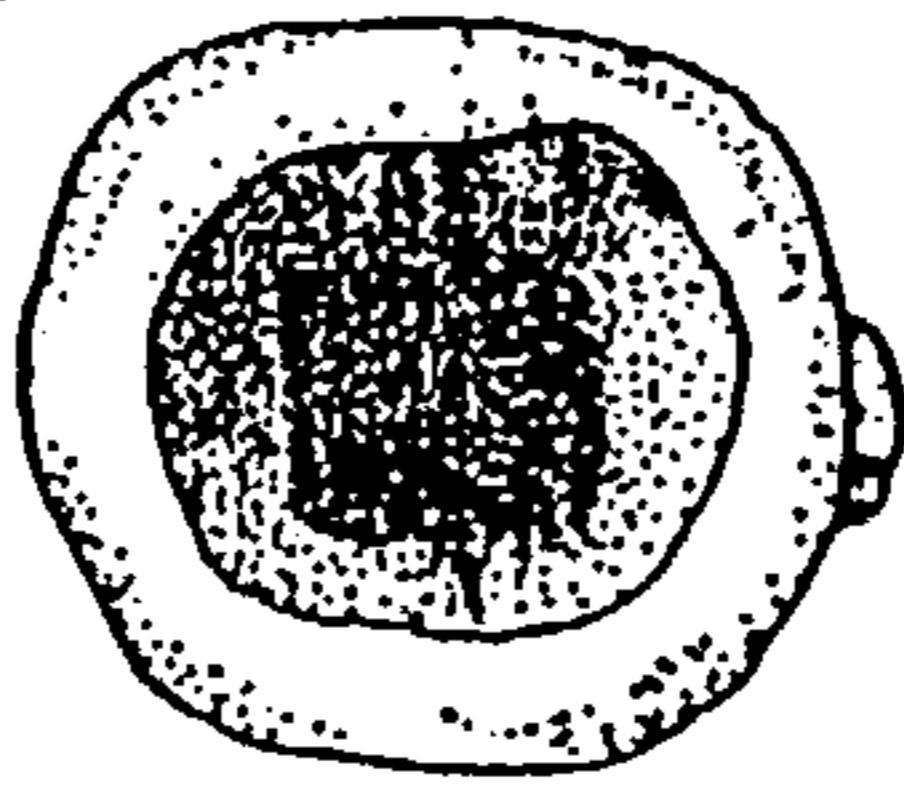
Description: Fragment from interior of copper cake, with voids in the interior.

Dimensions: Length: 31mm. Width: 26mm. Thickness: 13mm. Weight: 59.1g.

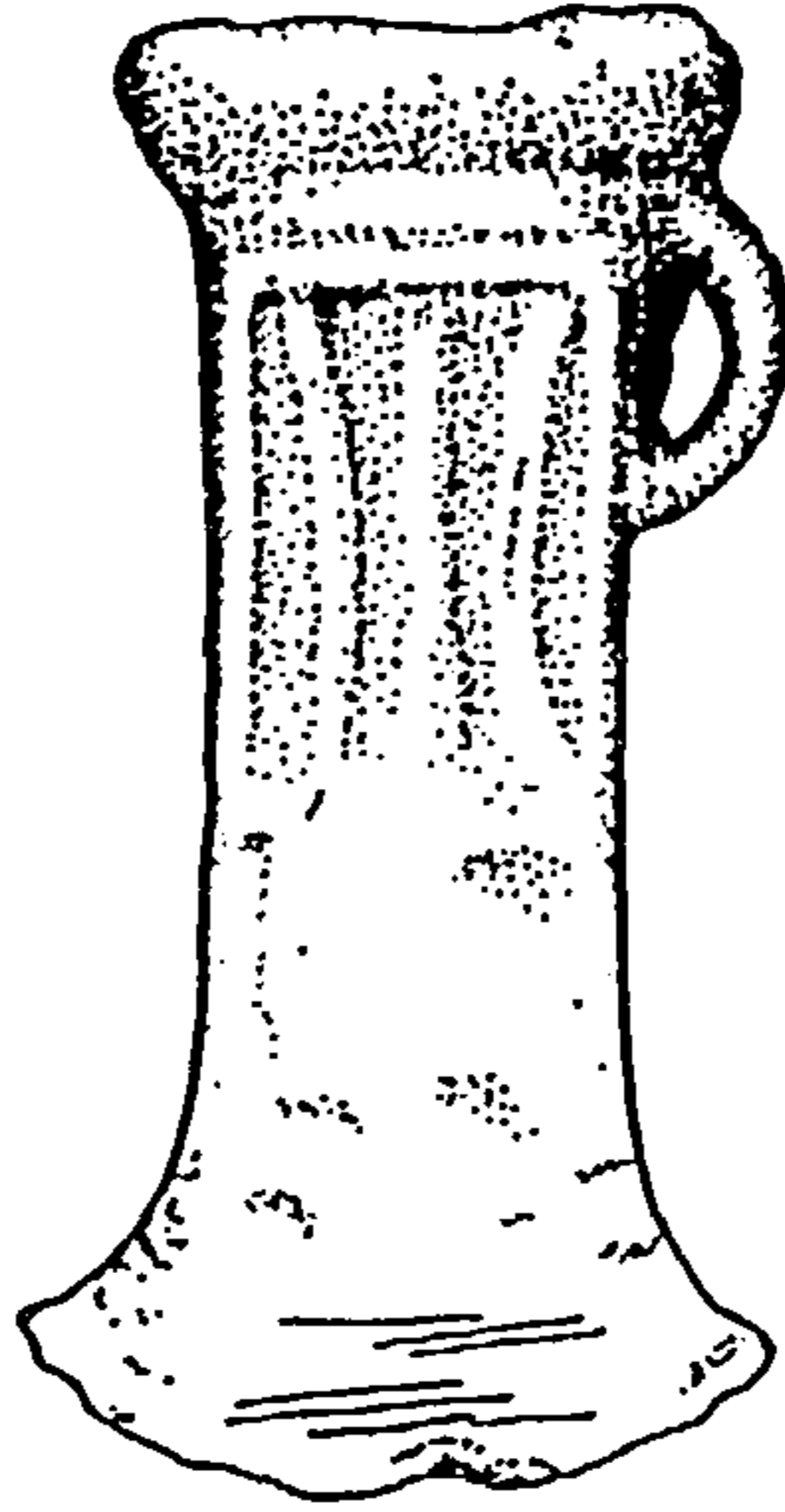
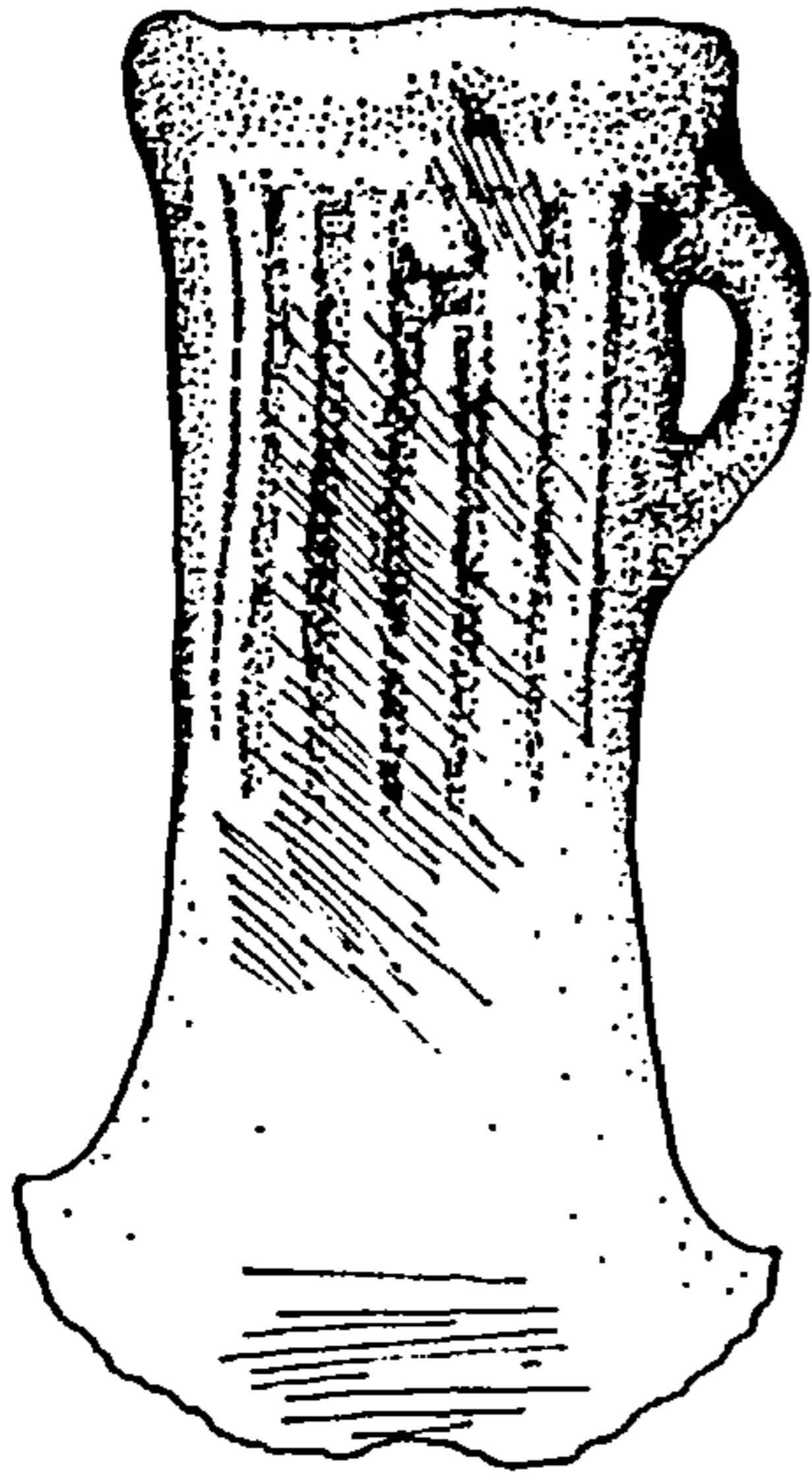
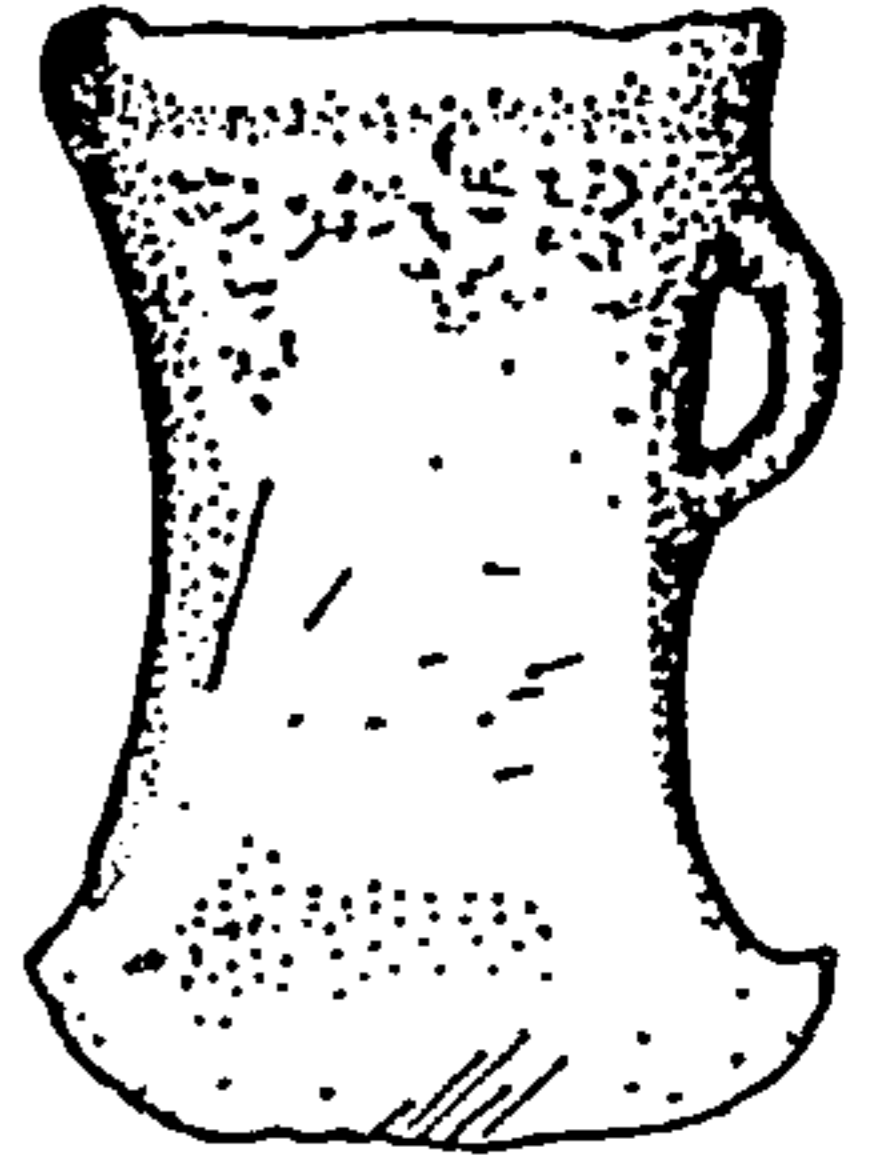
18/01



18/02

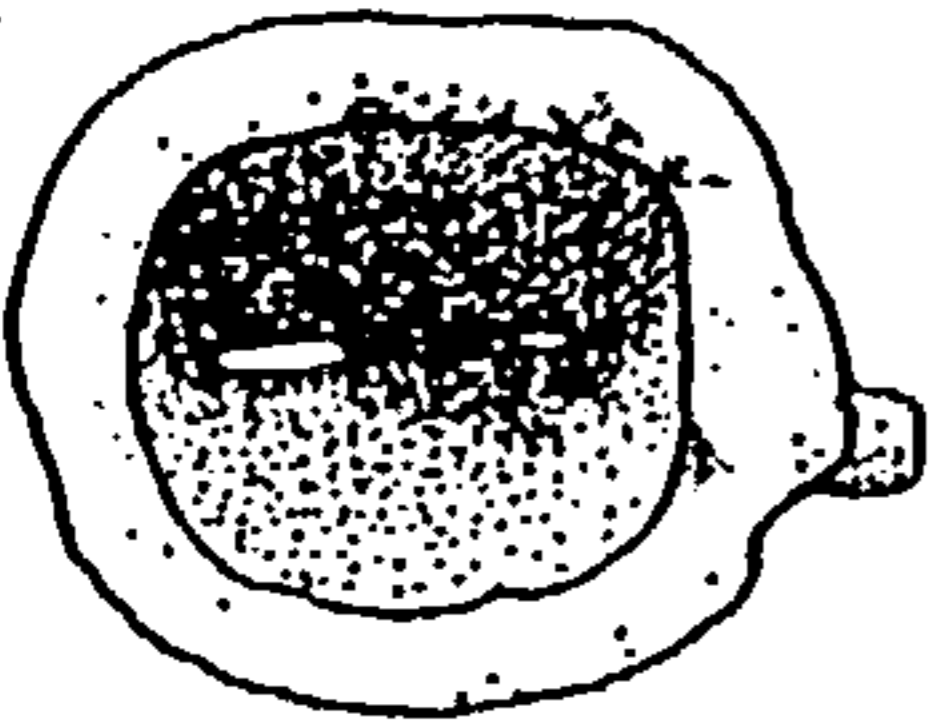


18/03

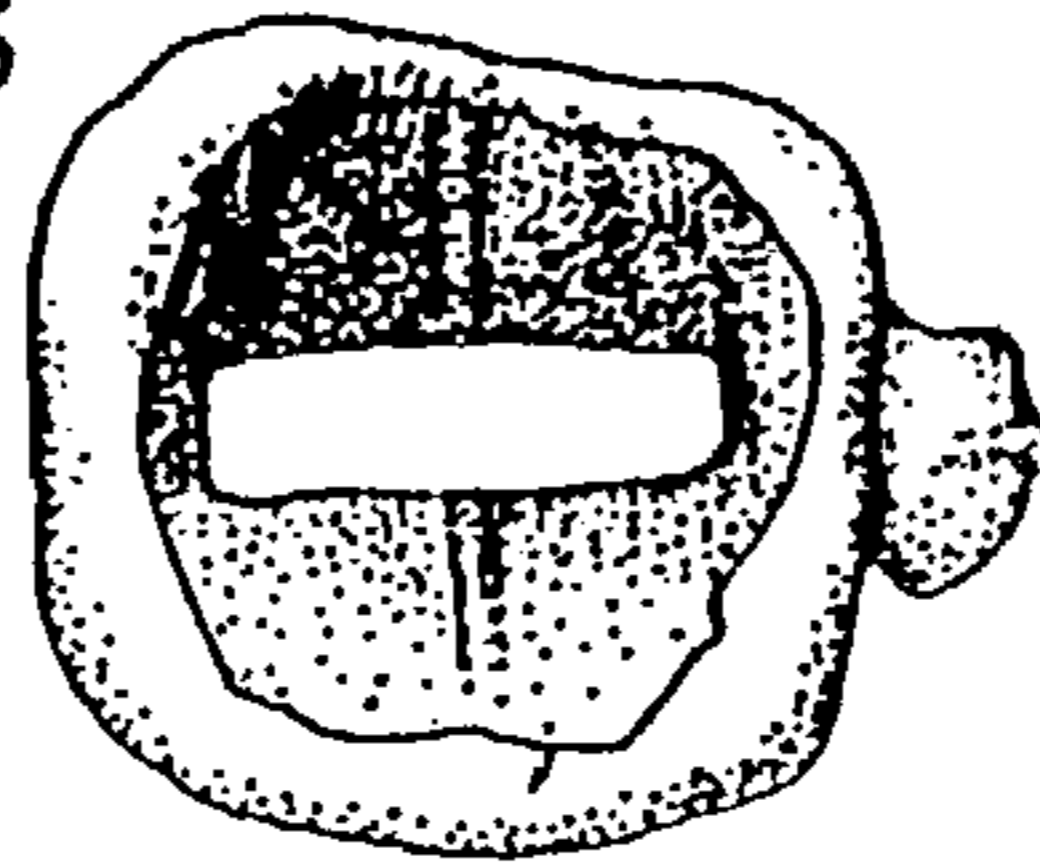


0 2cm

18/04



18/05



18/06

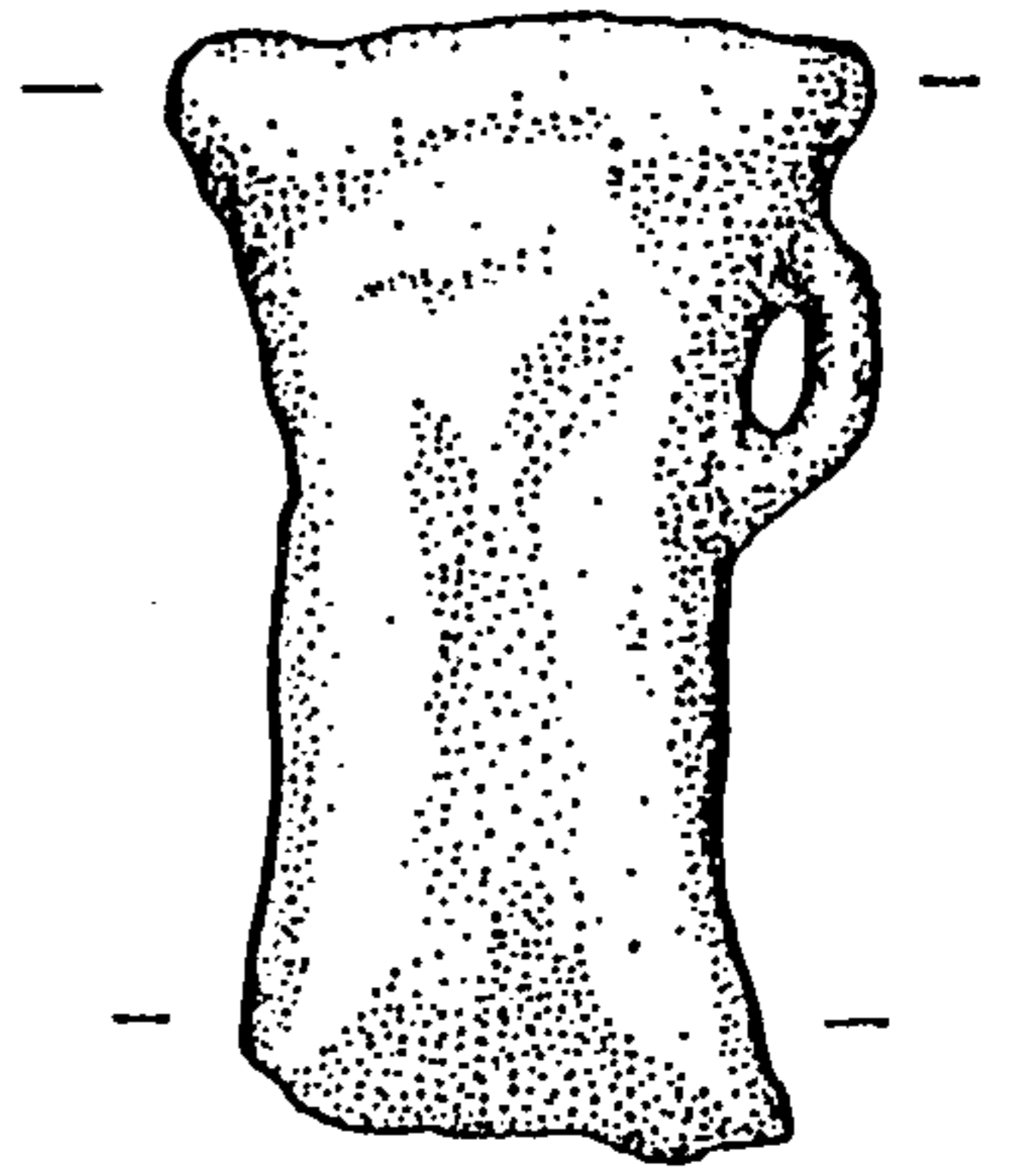
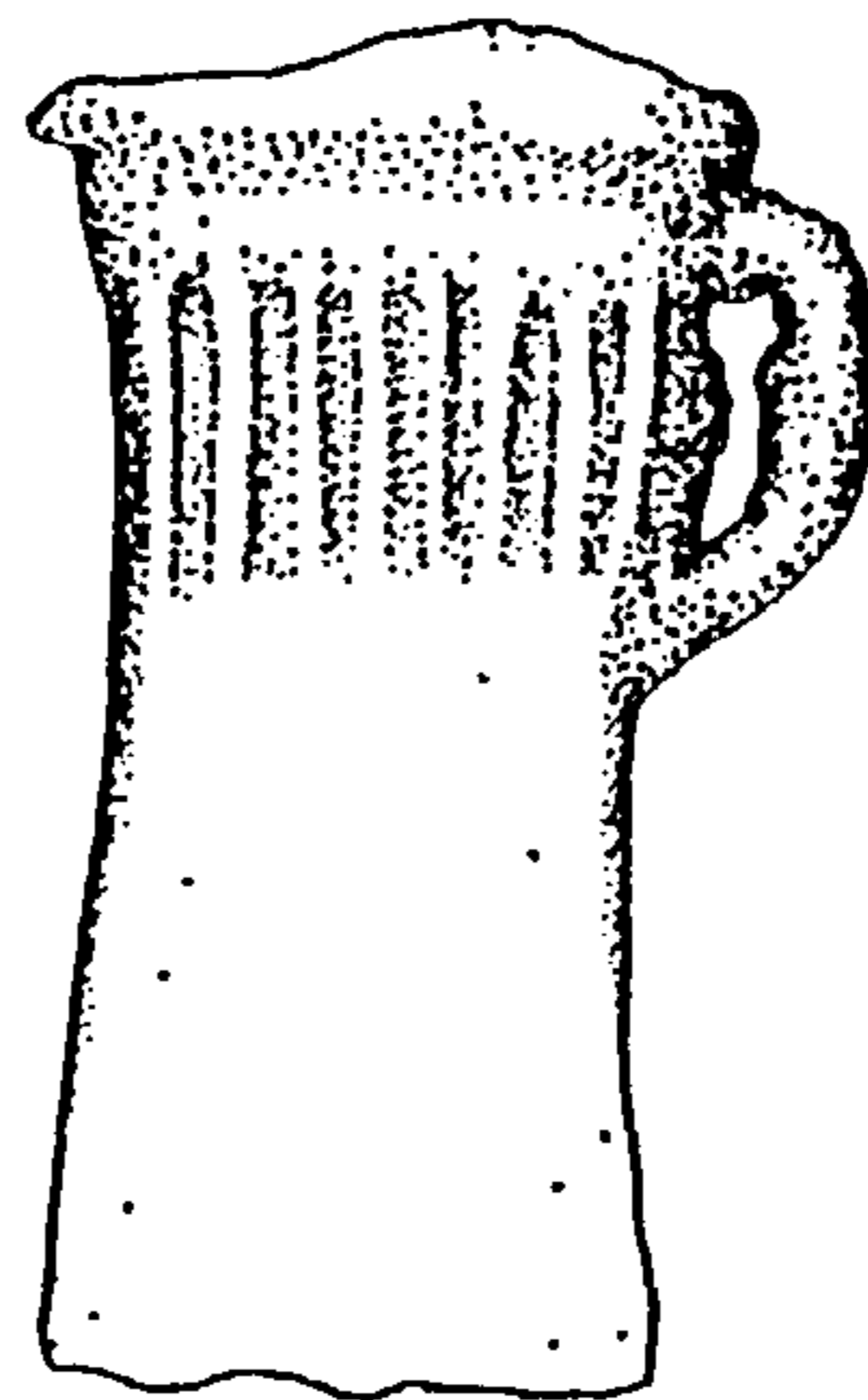
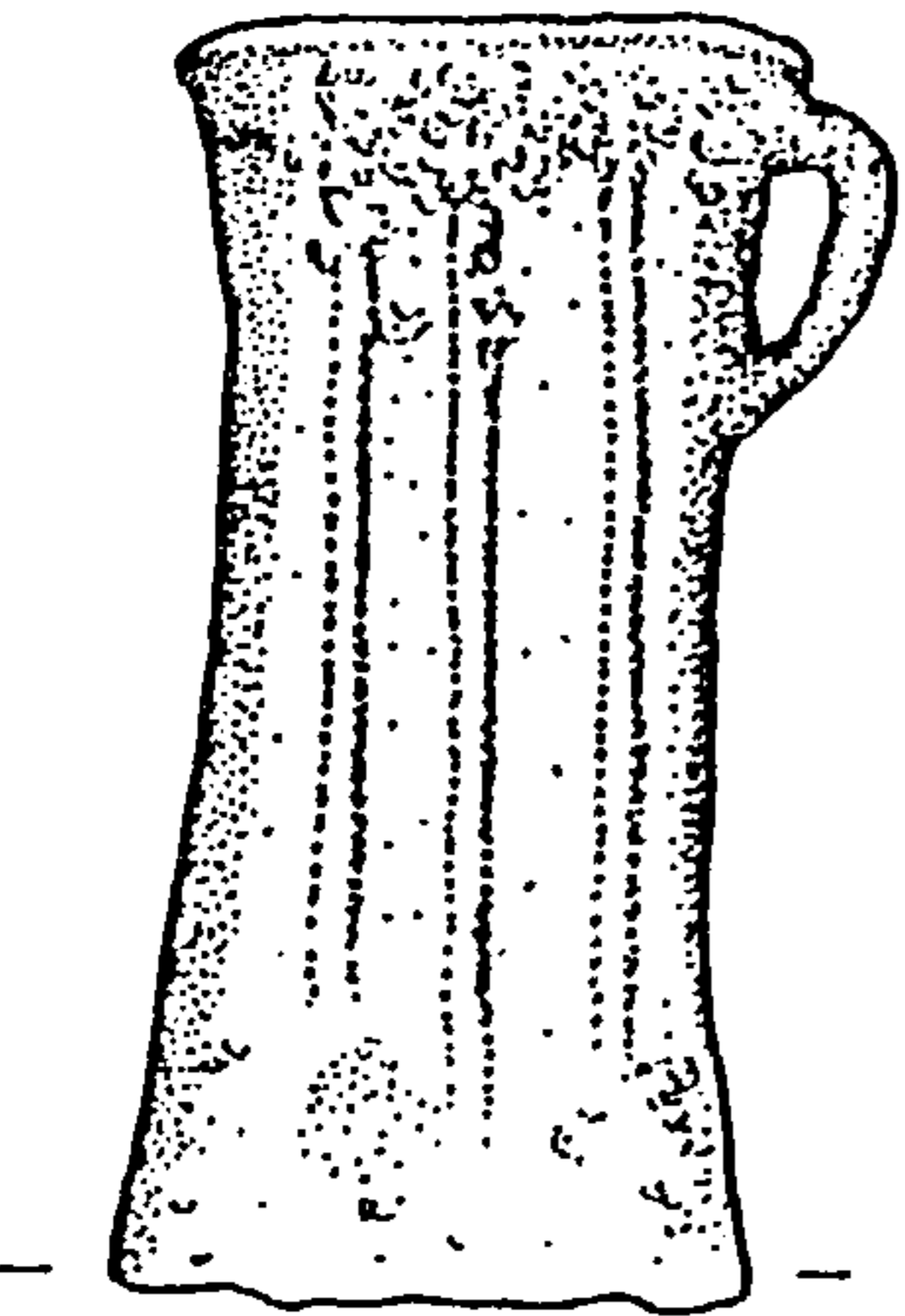
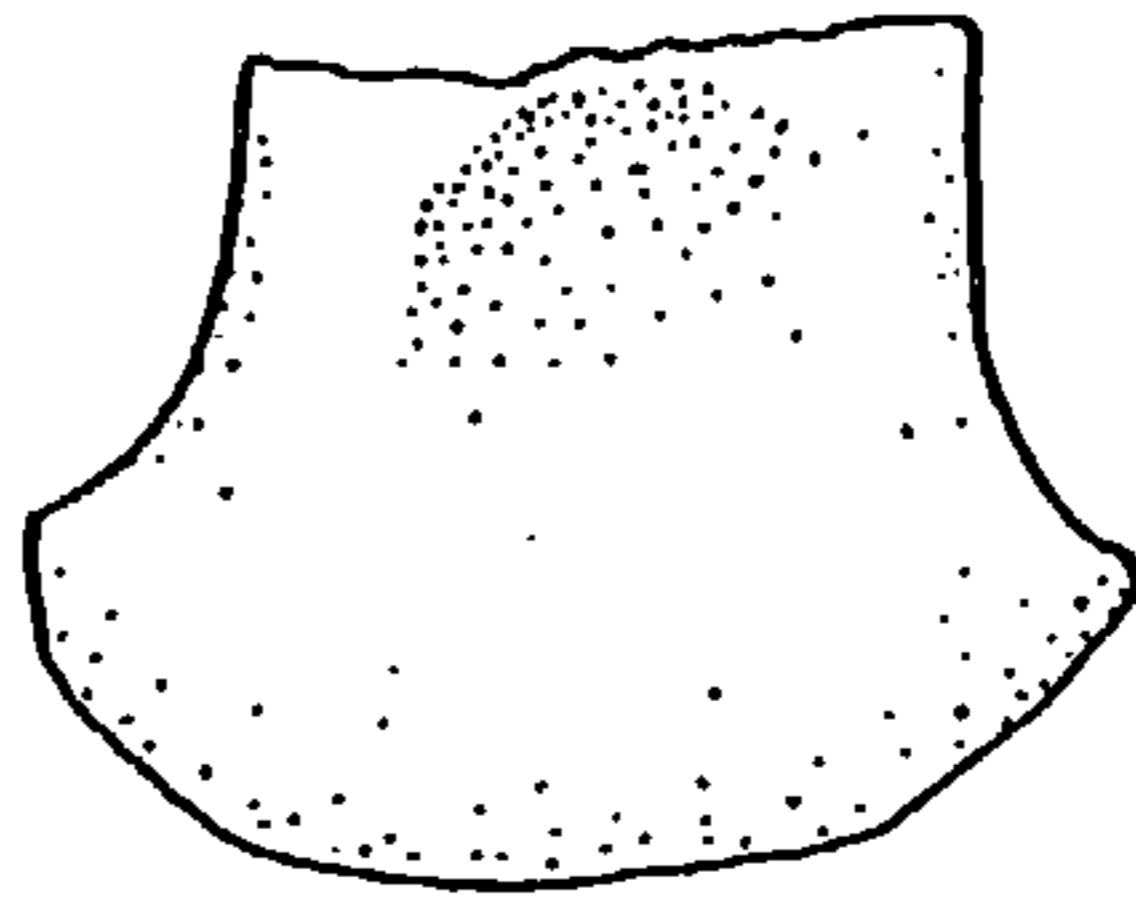


Fig. 35 The Dartford Hoard (Ref. No. 18): Socketed Axes

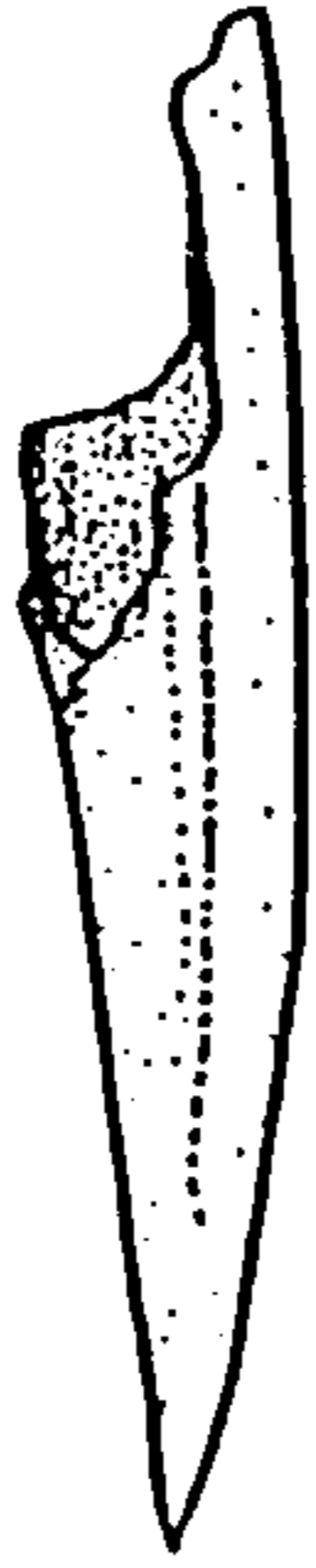
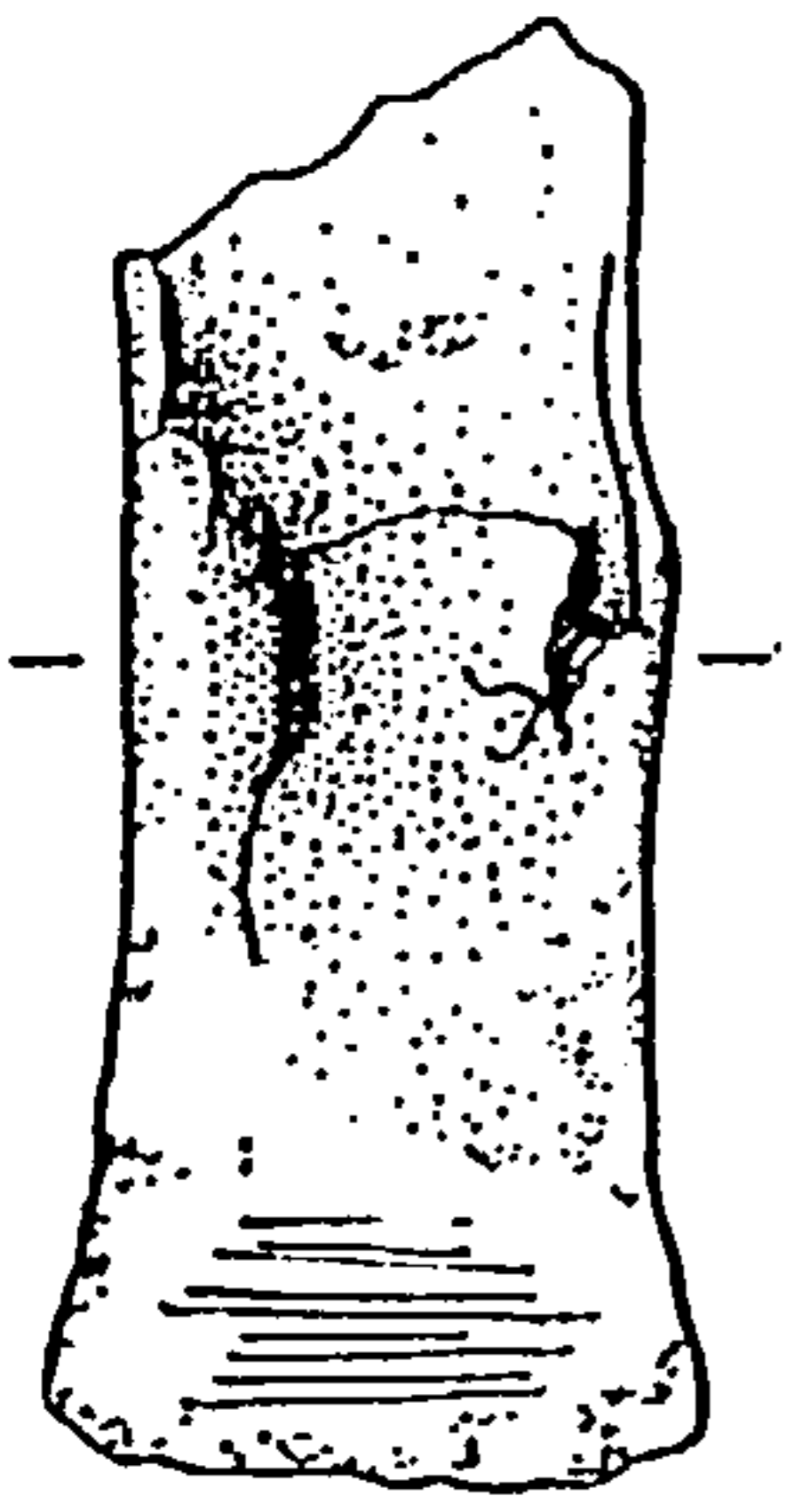
18/07



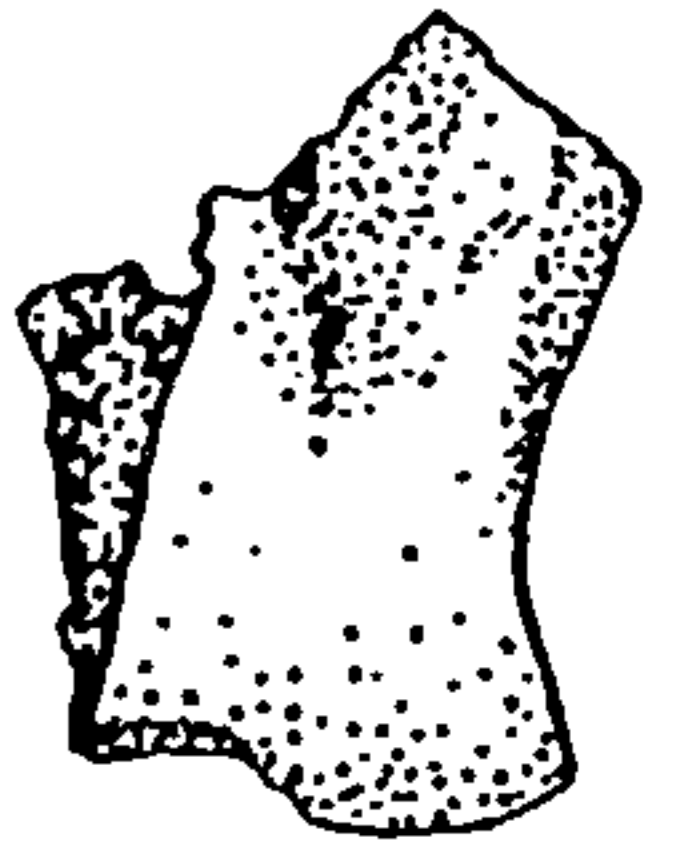
18/08



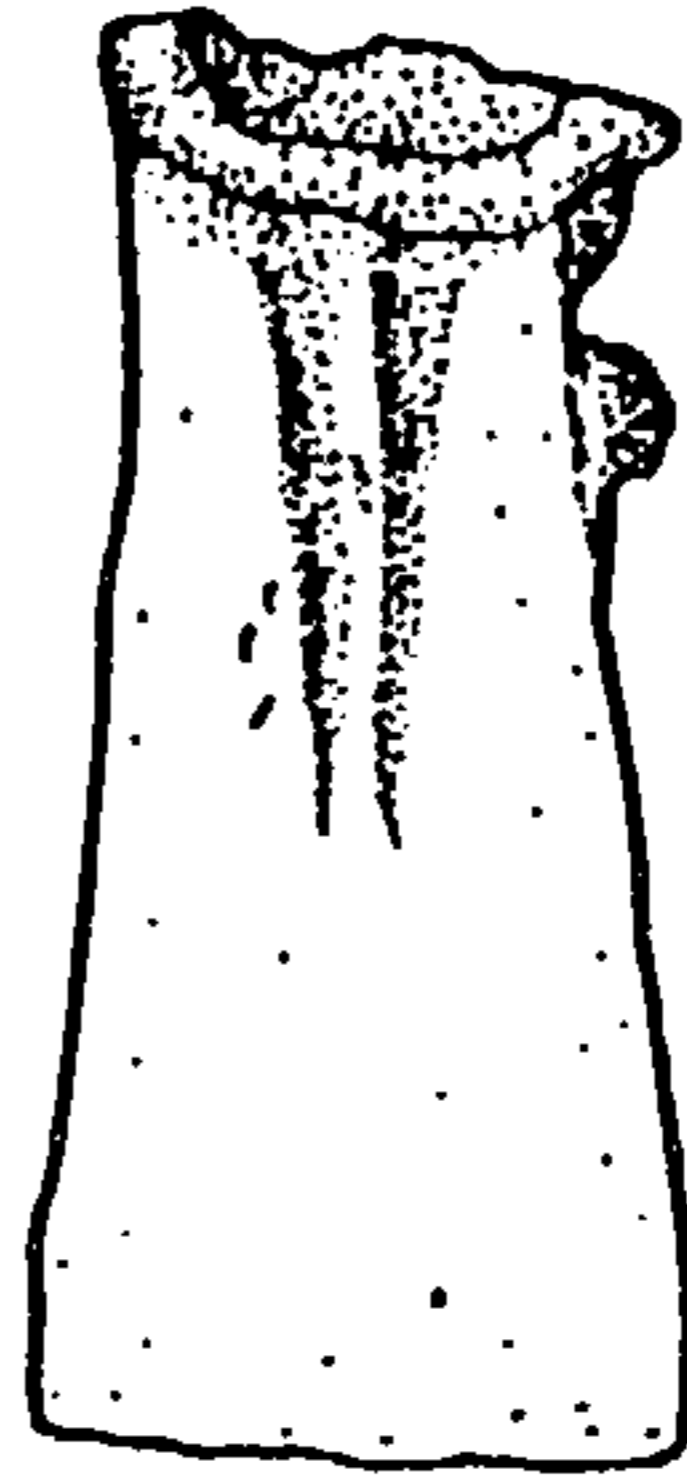
18/09



0 2cm

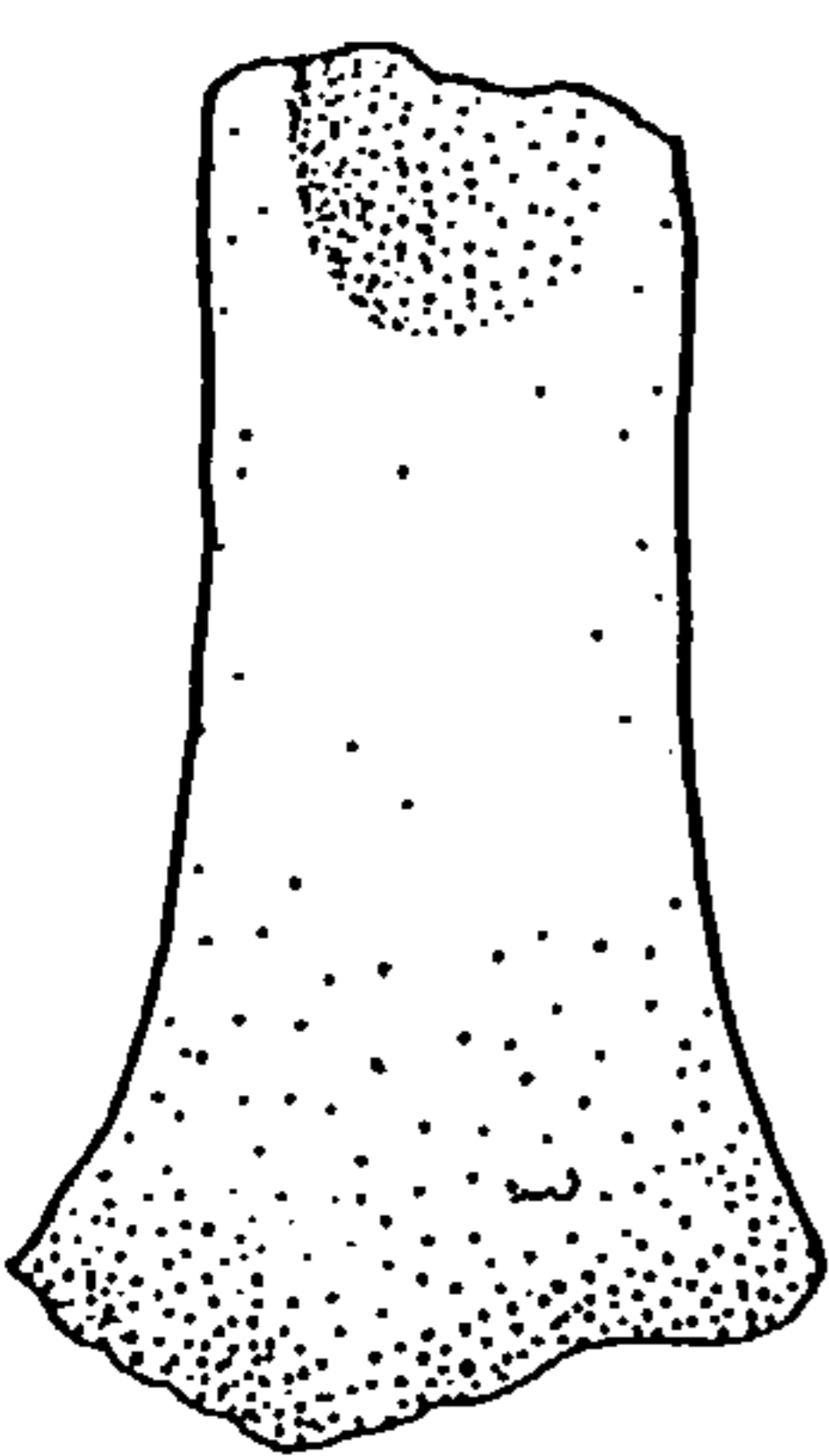


18/11

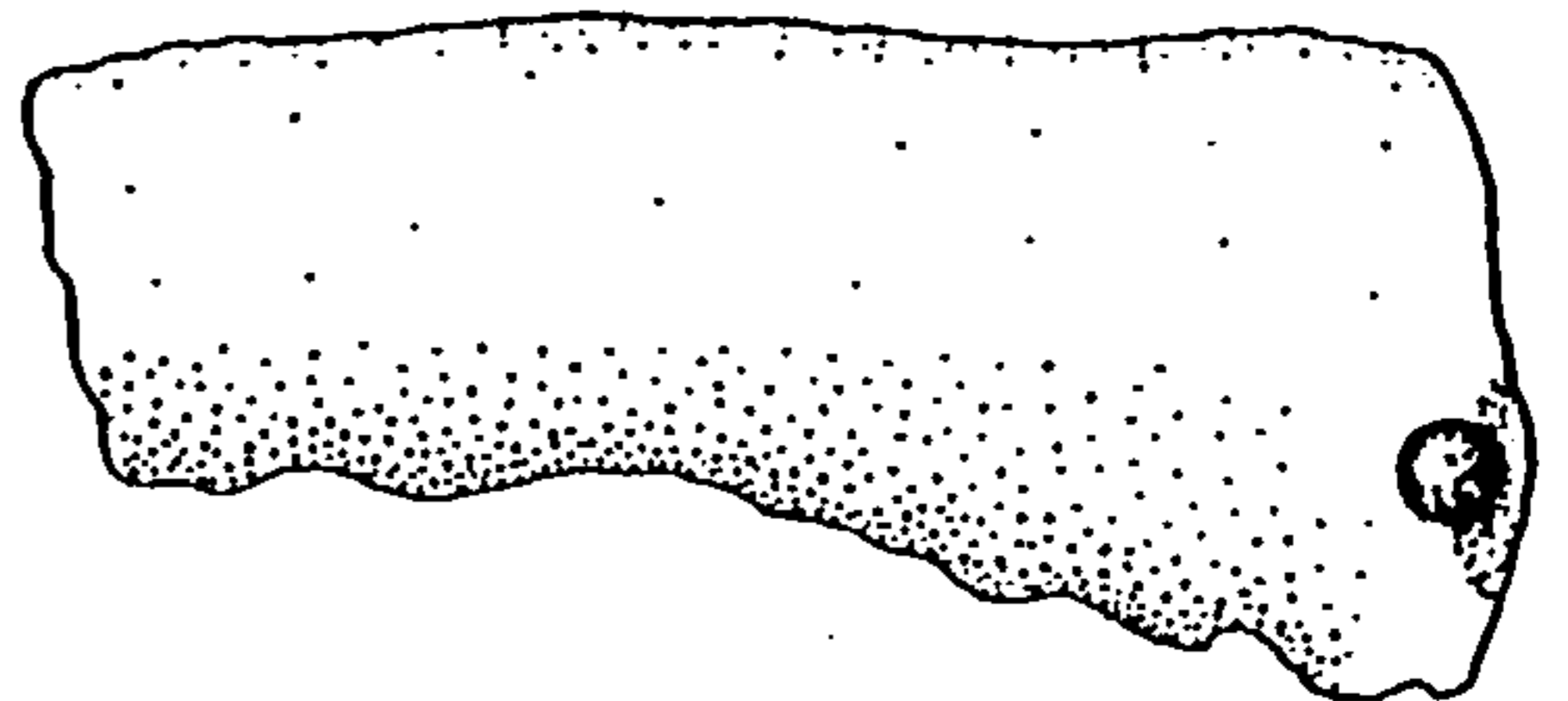


 Clay

18/10



18/12



18/13

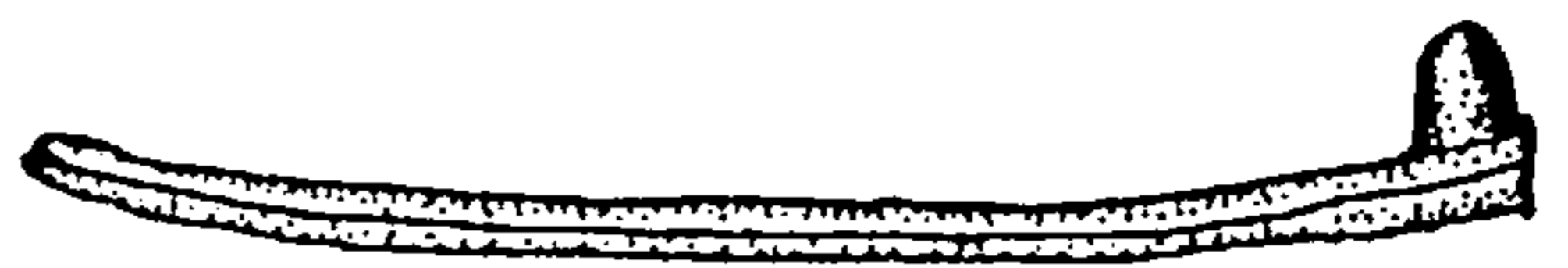
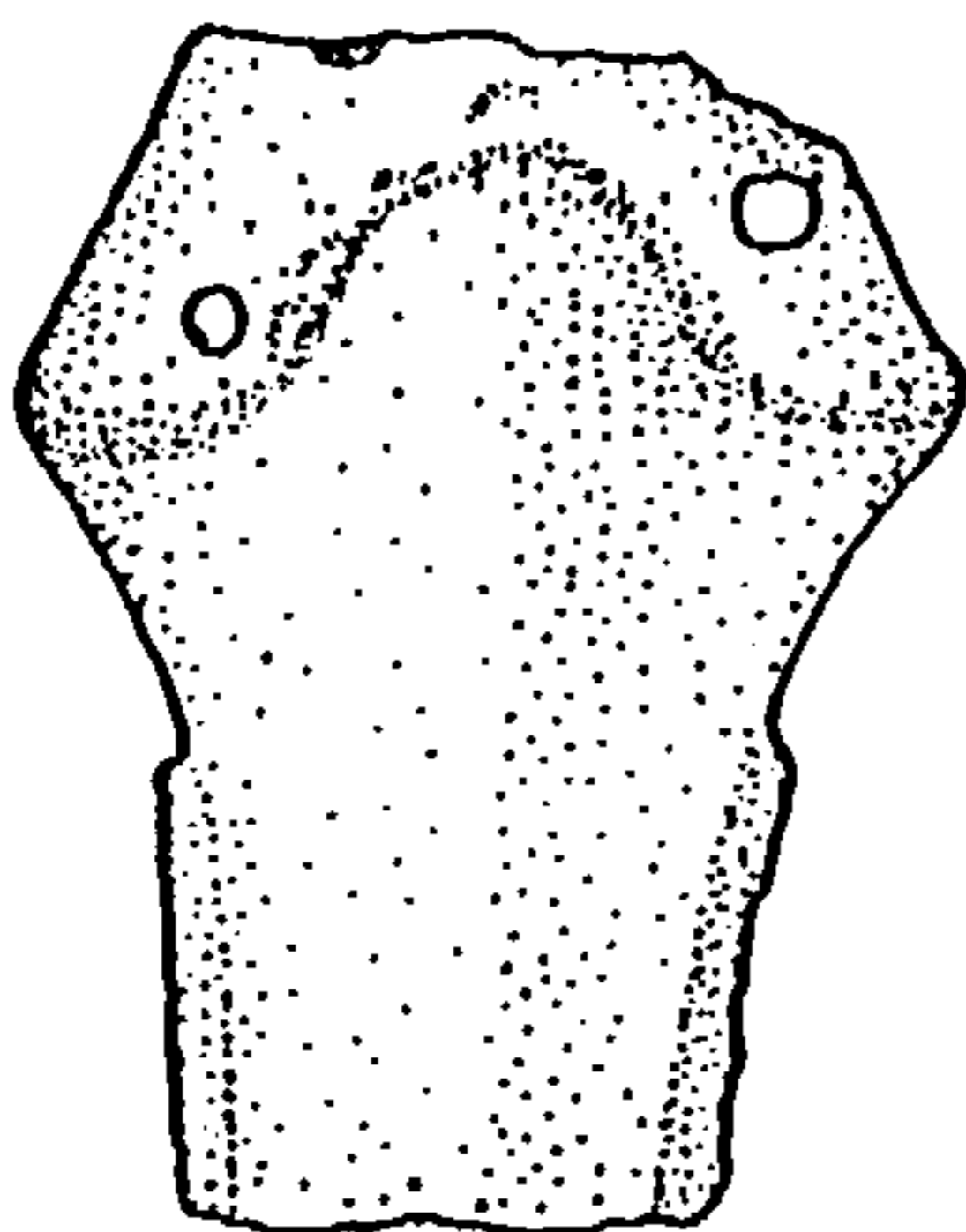
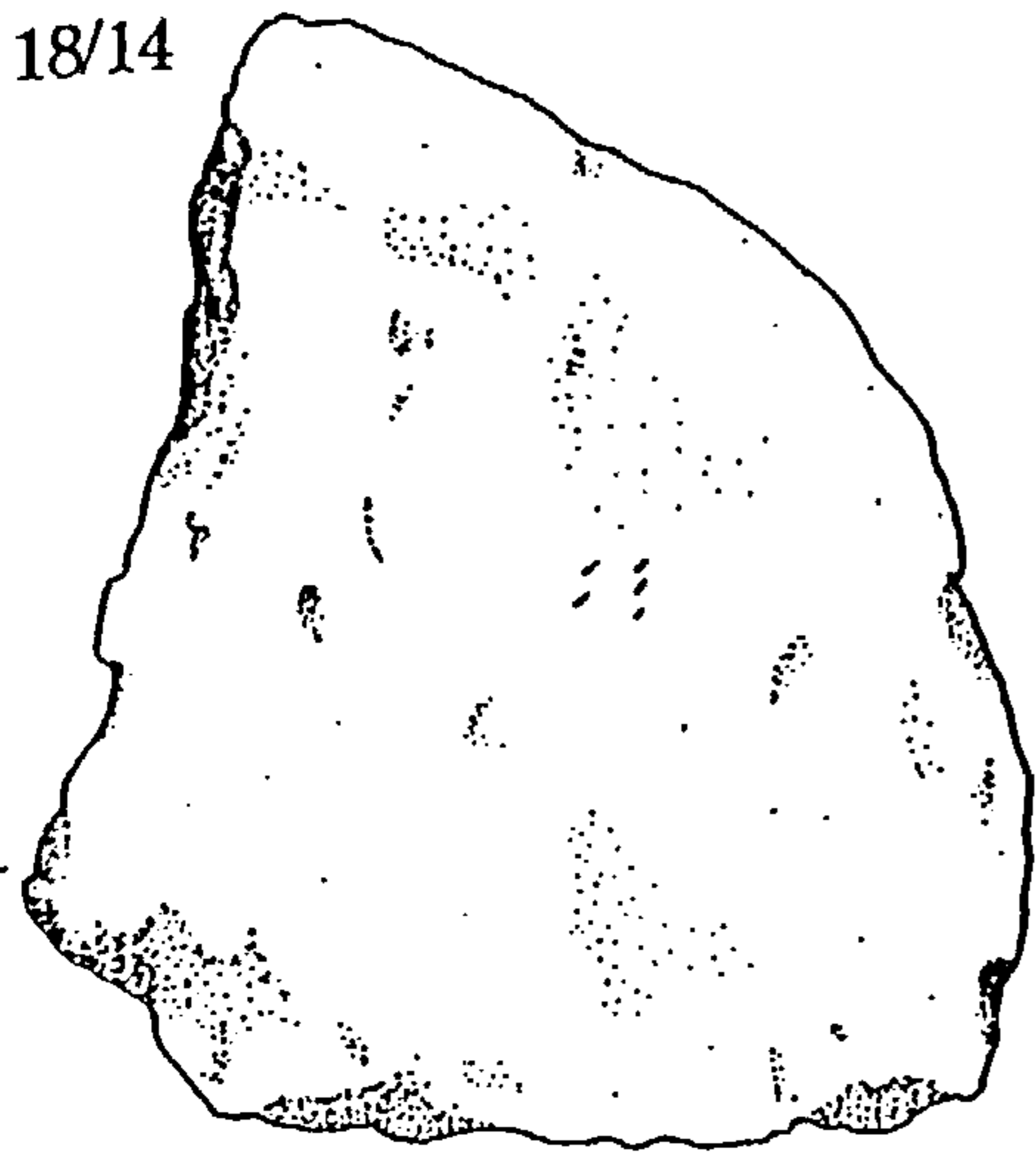
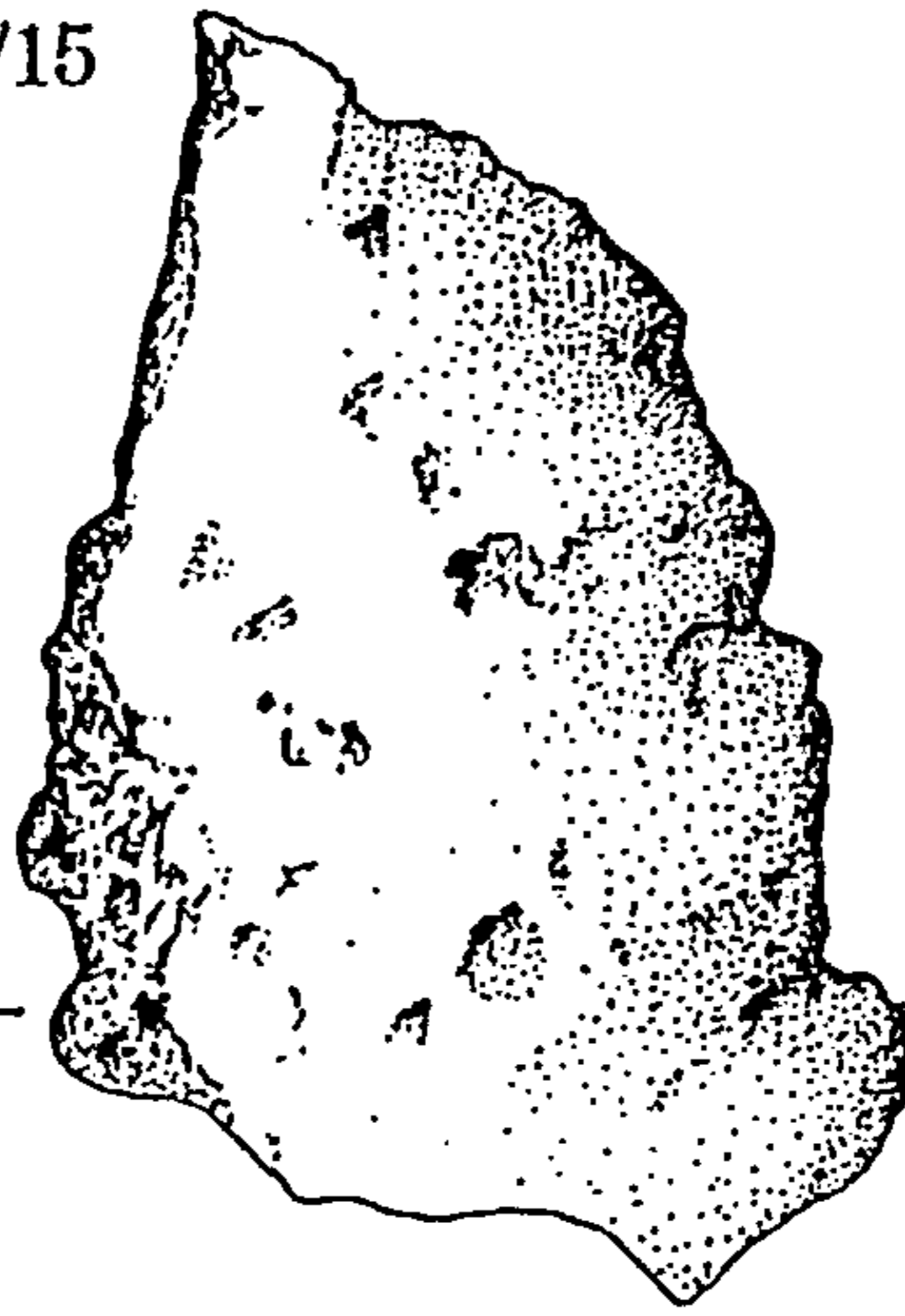


Fig. 36 The Dartford Hoard (Ref. No. 18): Axe, Small Tool and Weapon Fragments

18/14

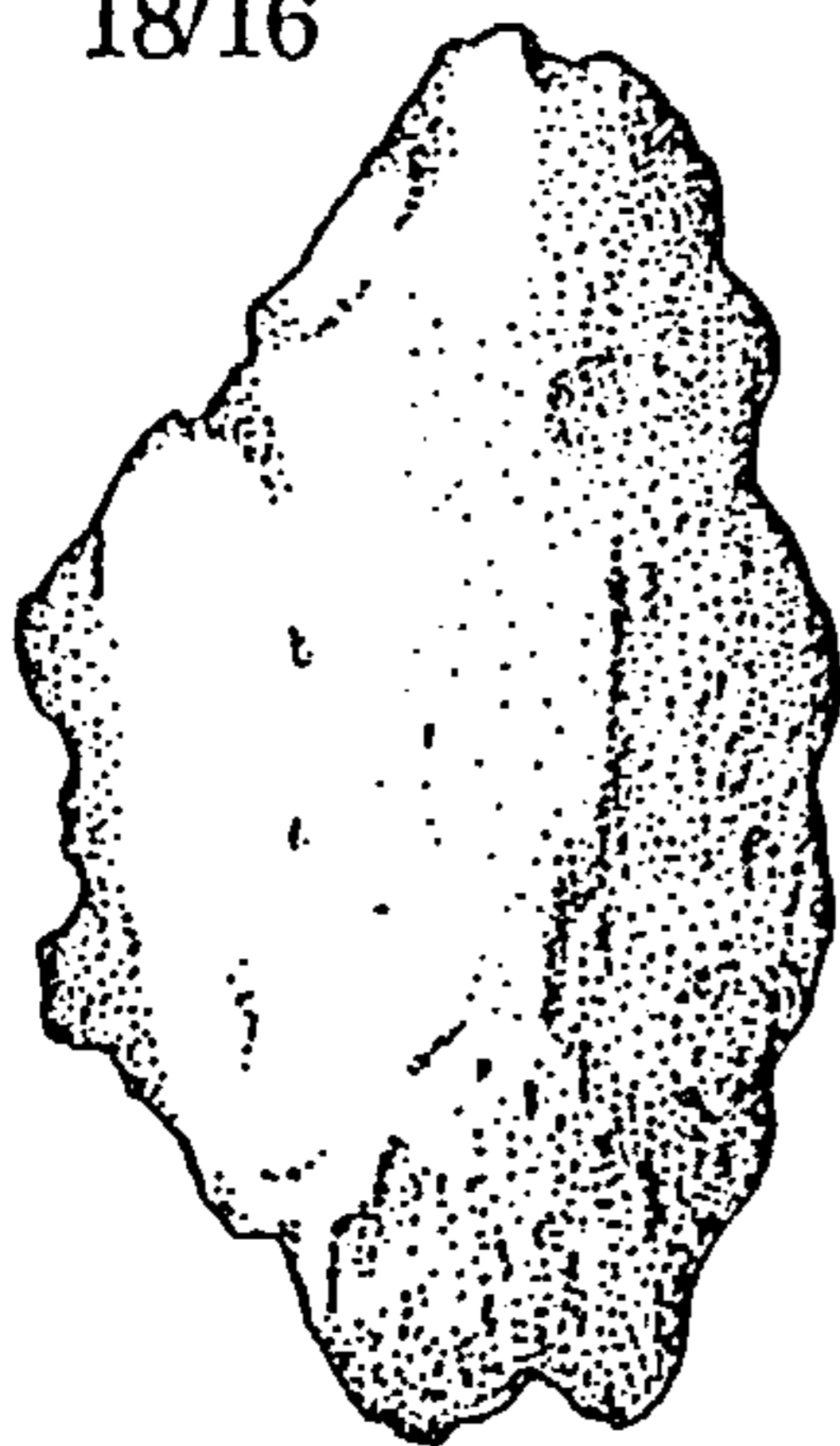


18/15

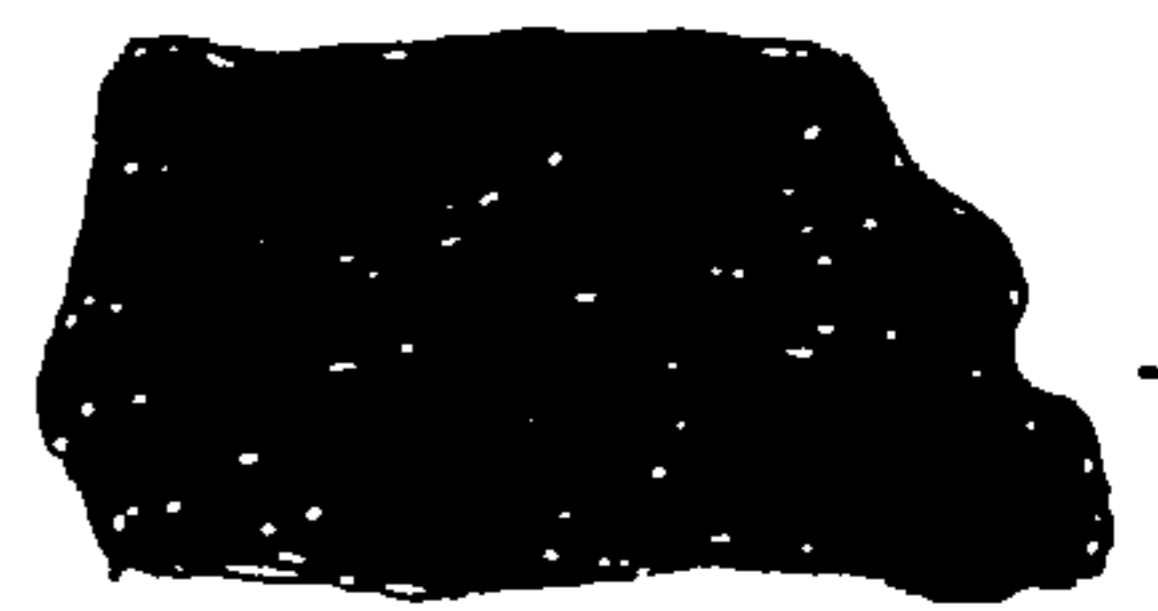
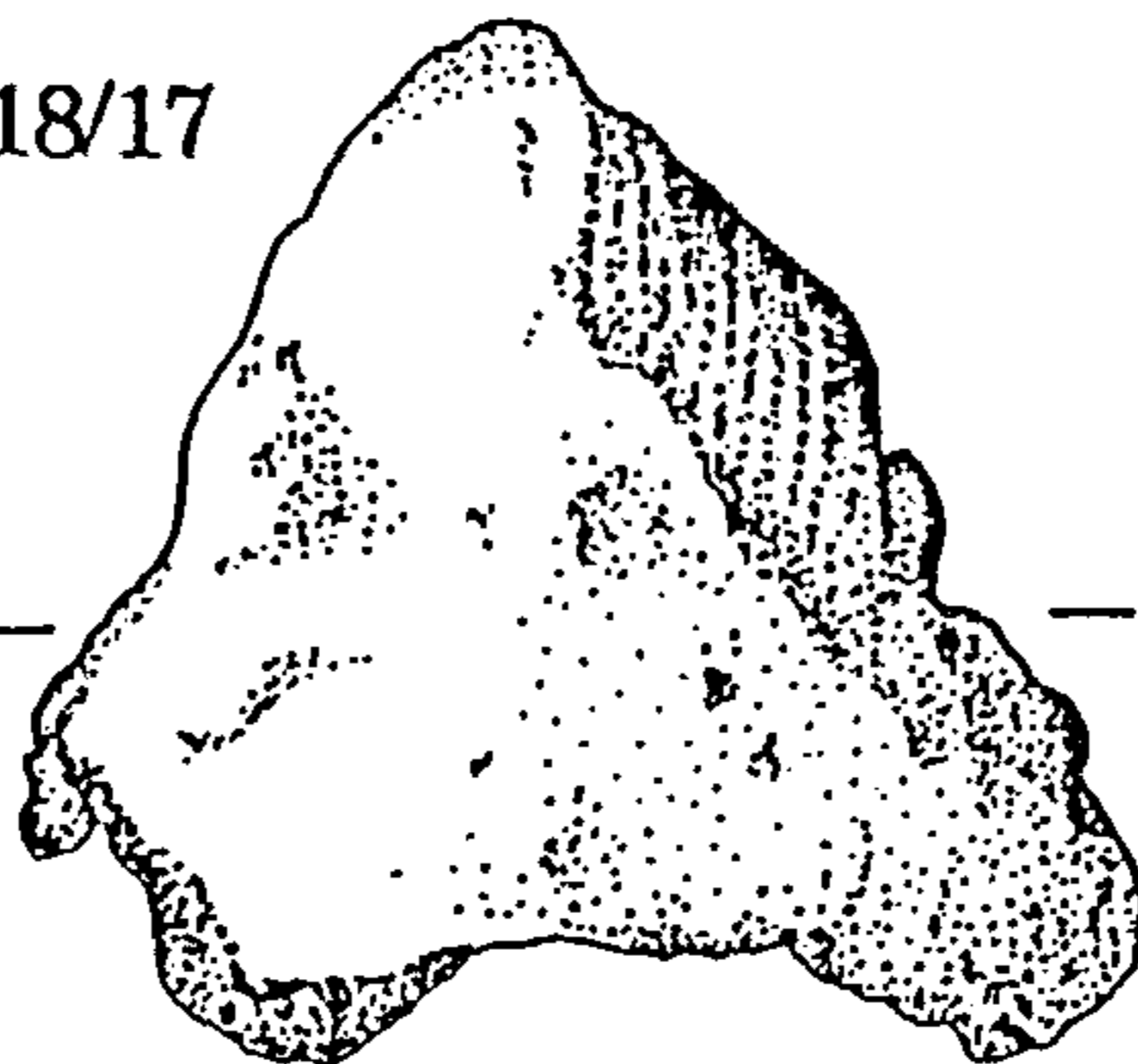


0 2cm

18/16



18/17

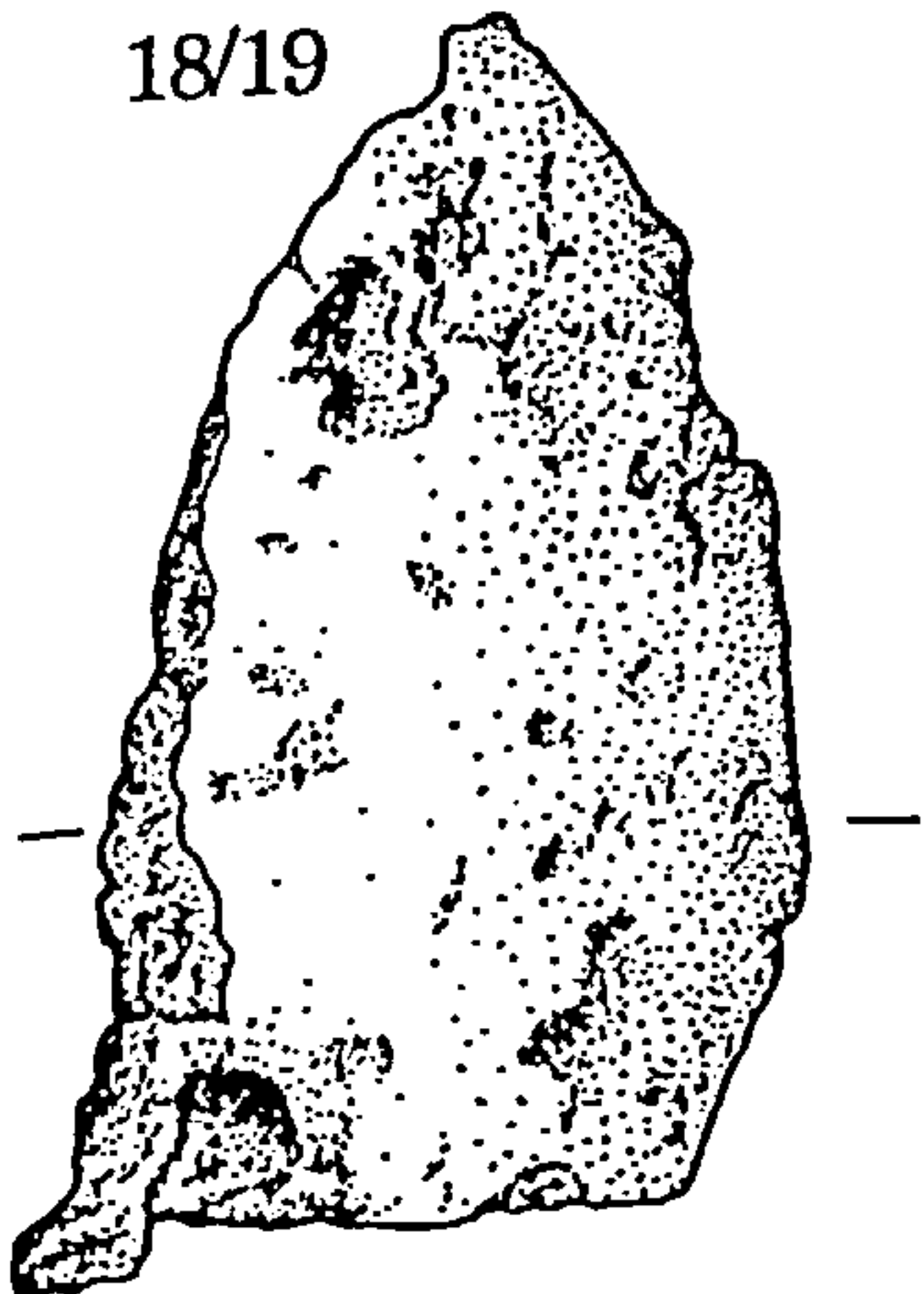


18/18

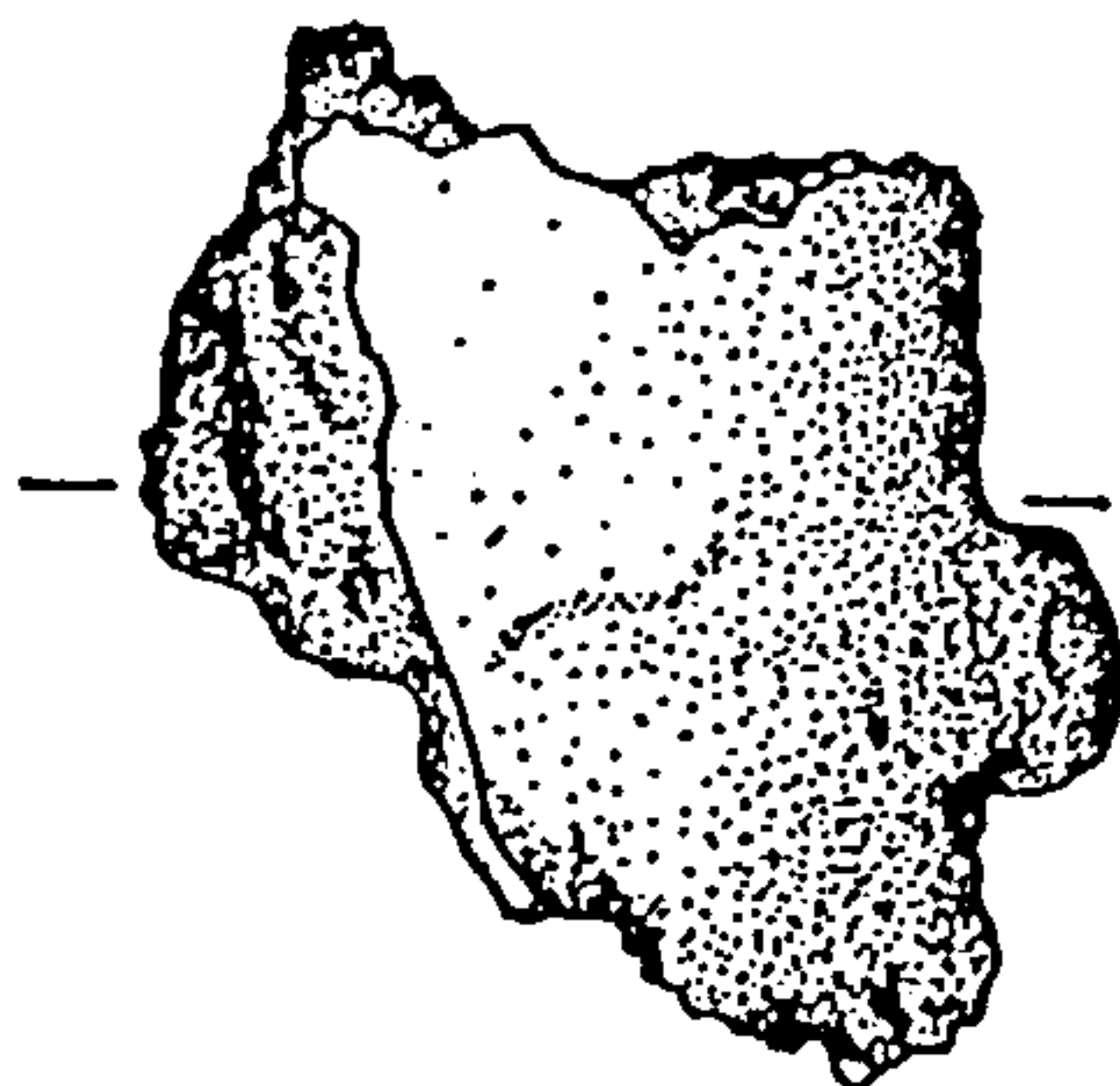


Fig. 37 The Dartford Hoard (Ref. No. 18): Ingot Metal (i)

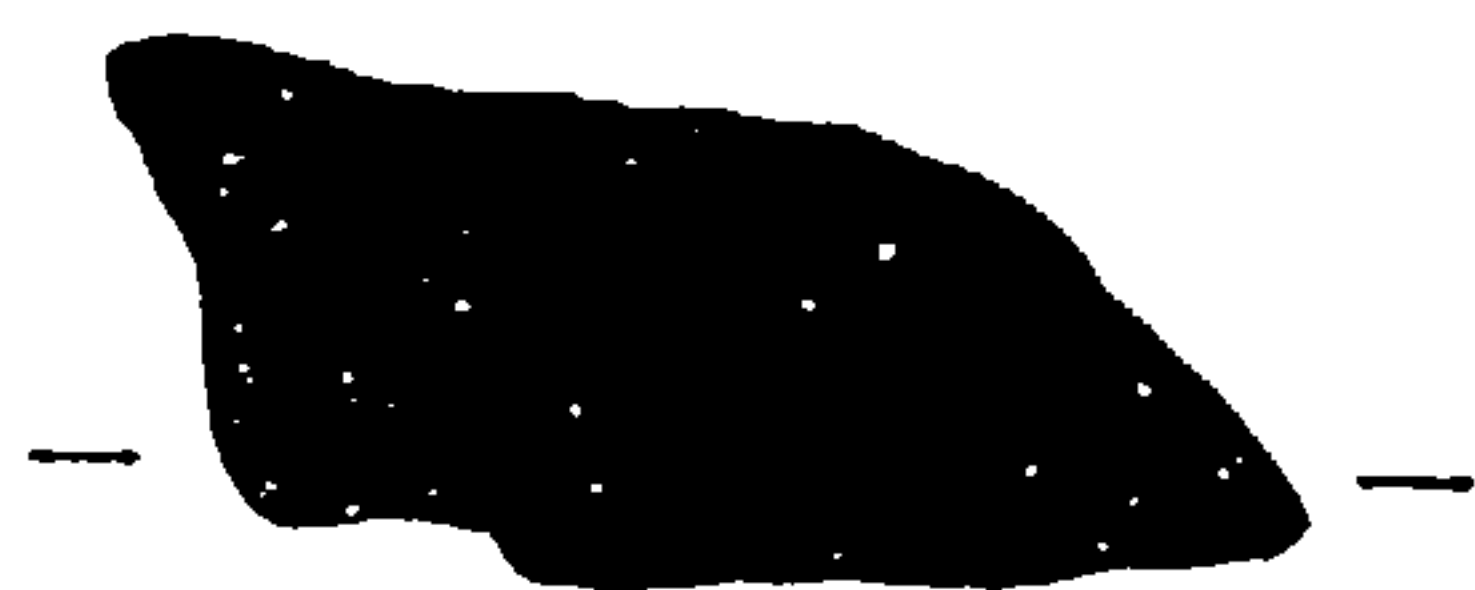
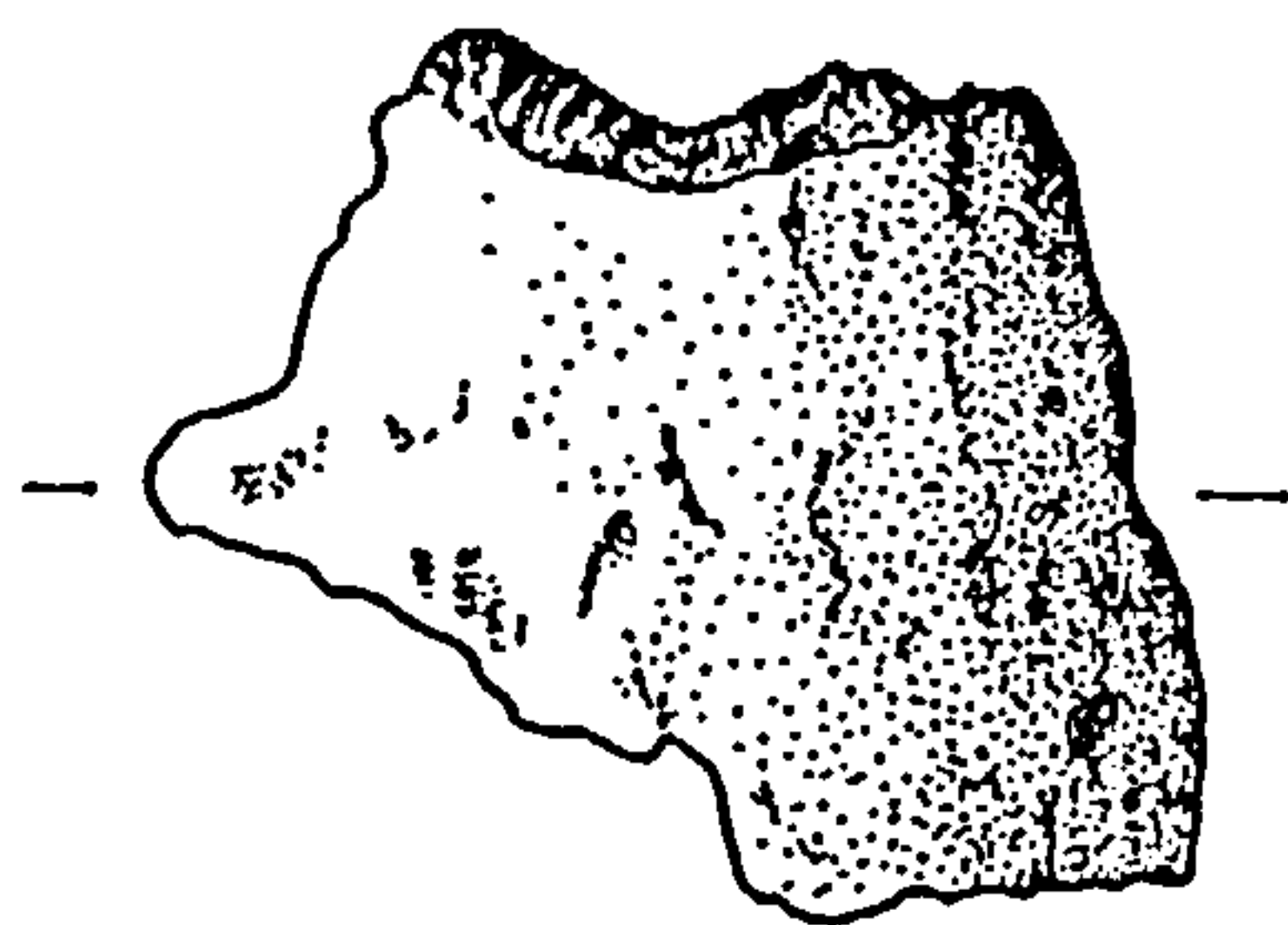
18/19



18/20



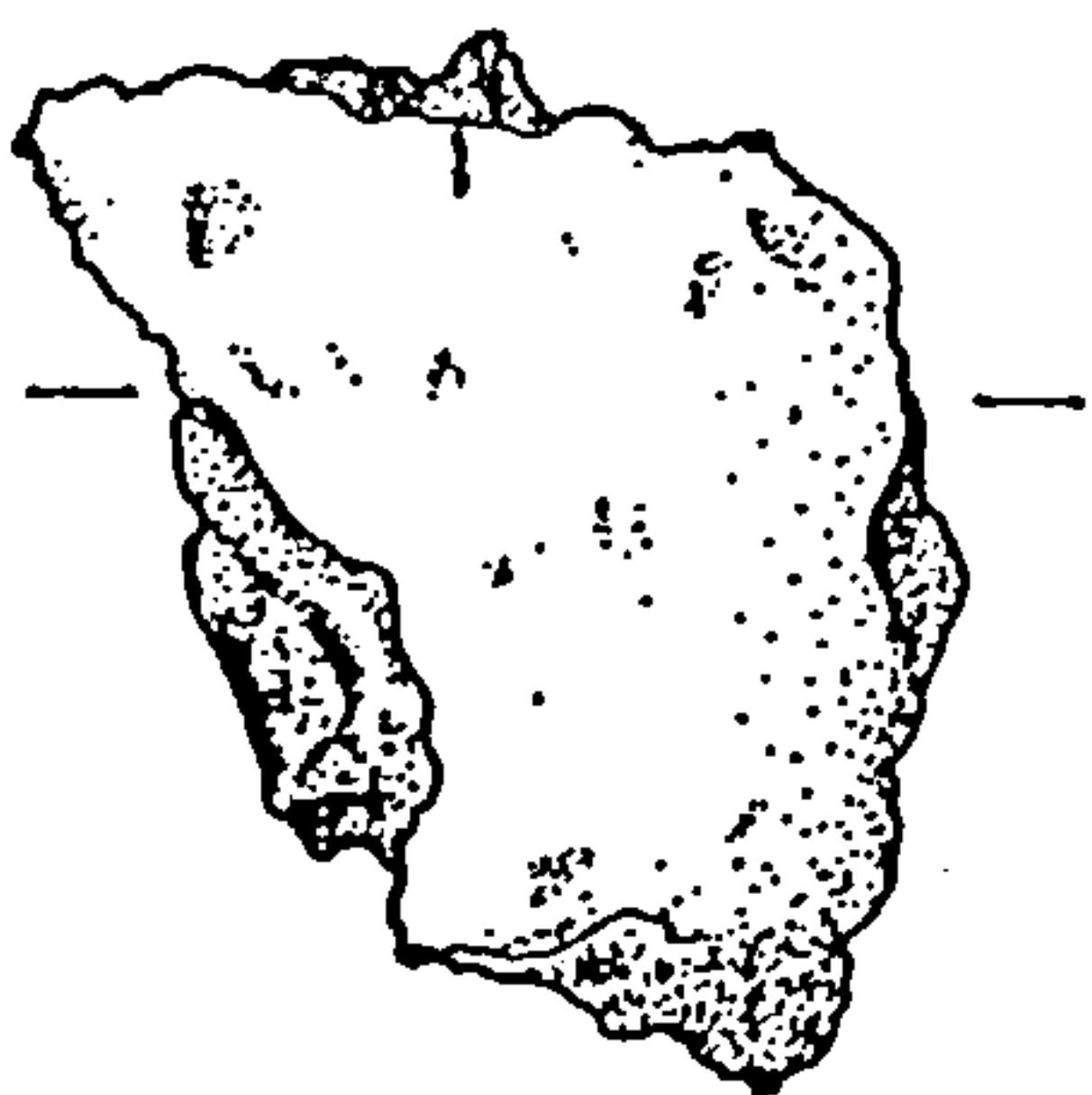
18/21



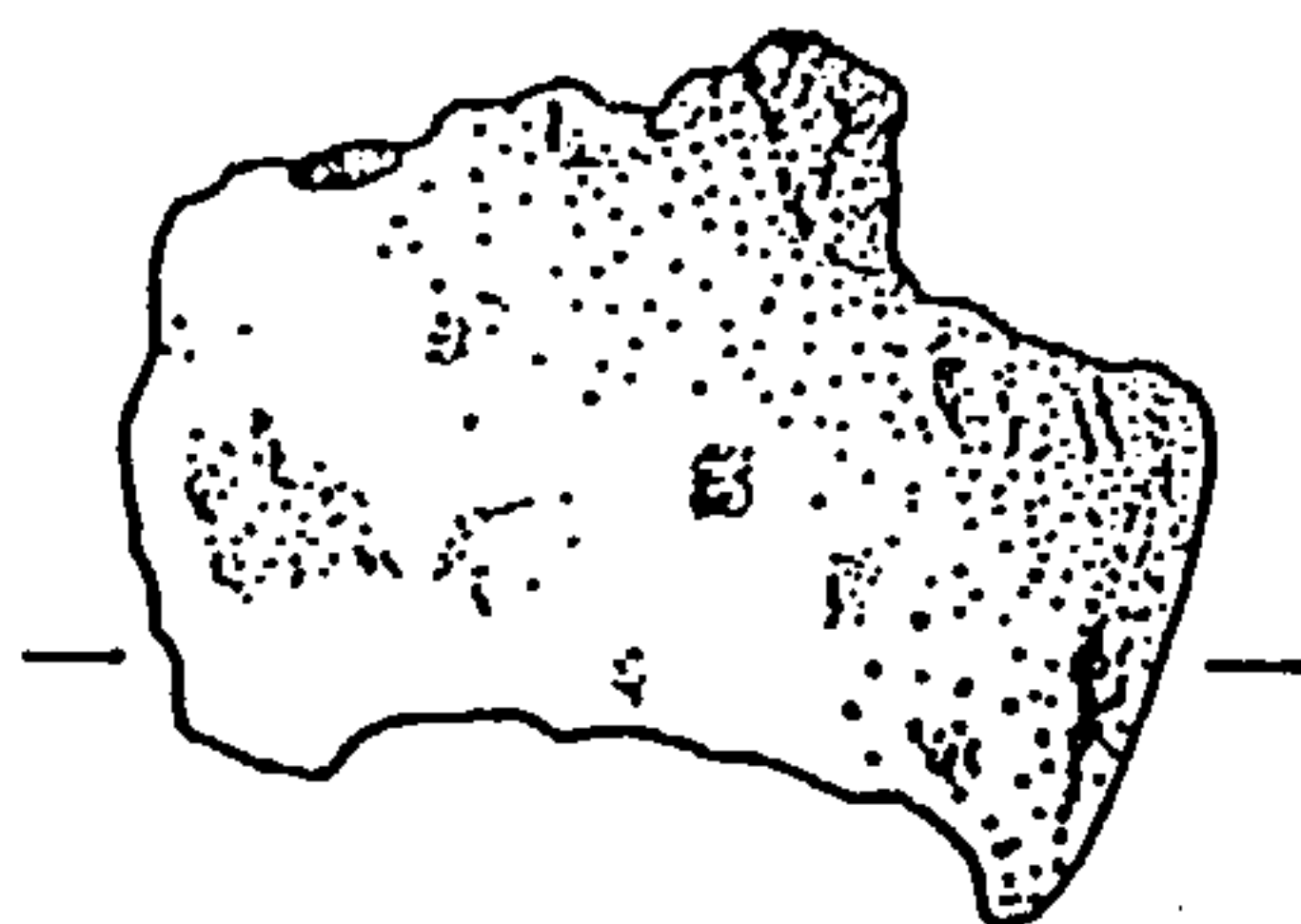
0 2cm



18/22



18/23



18/24

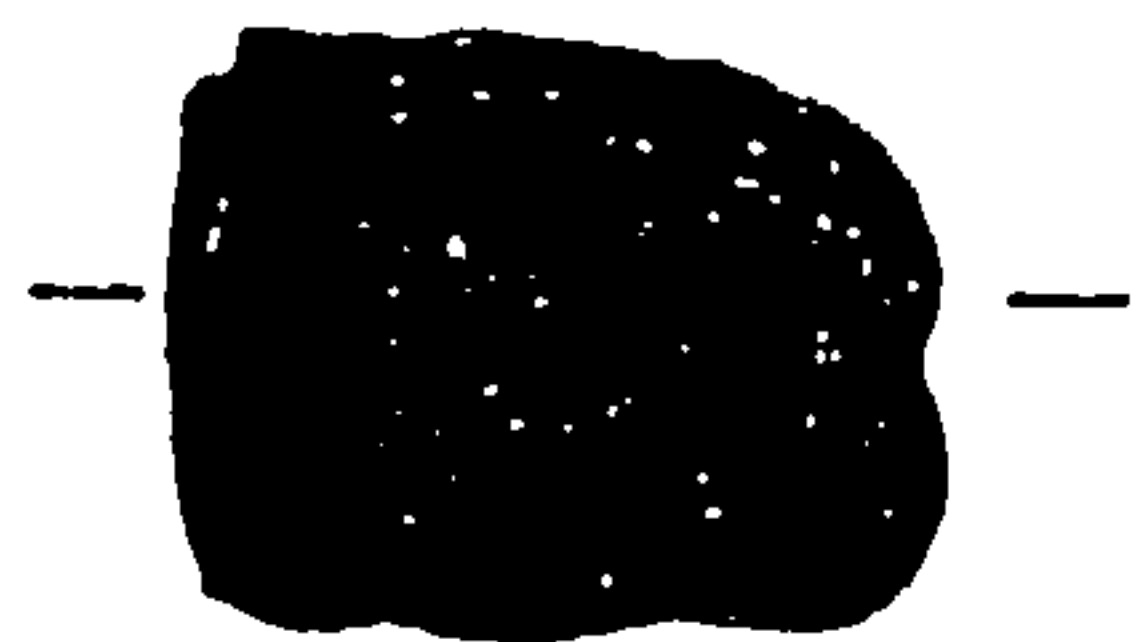
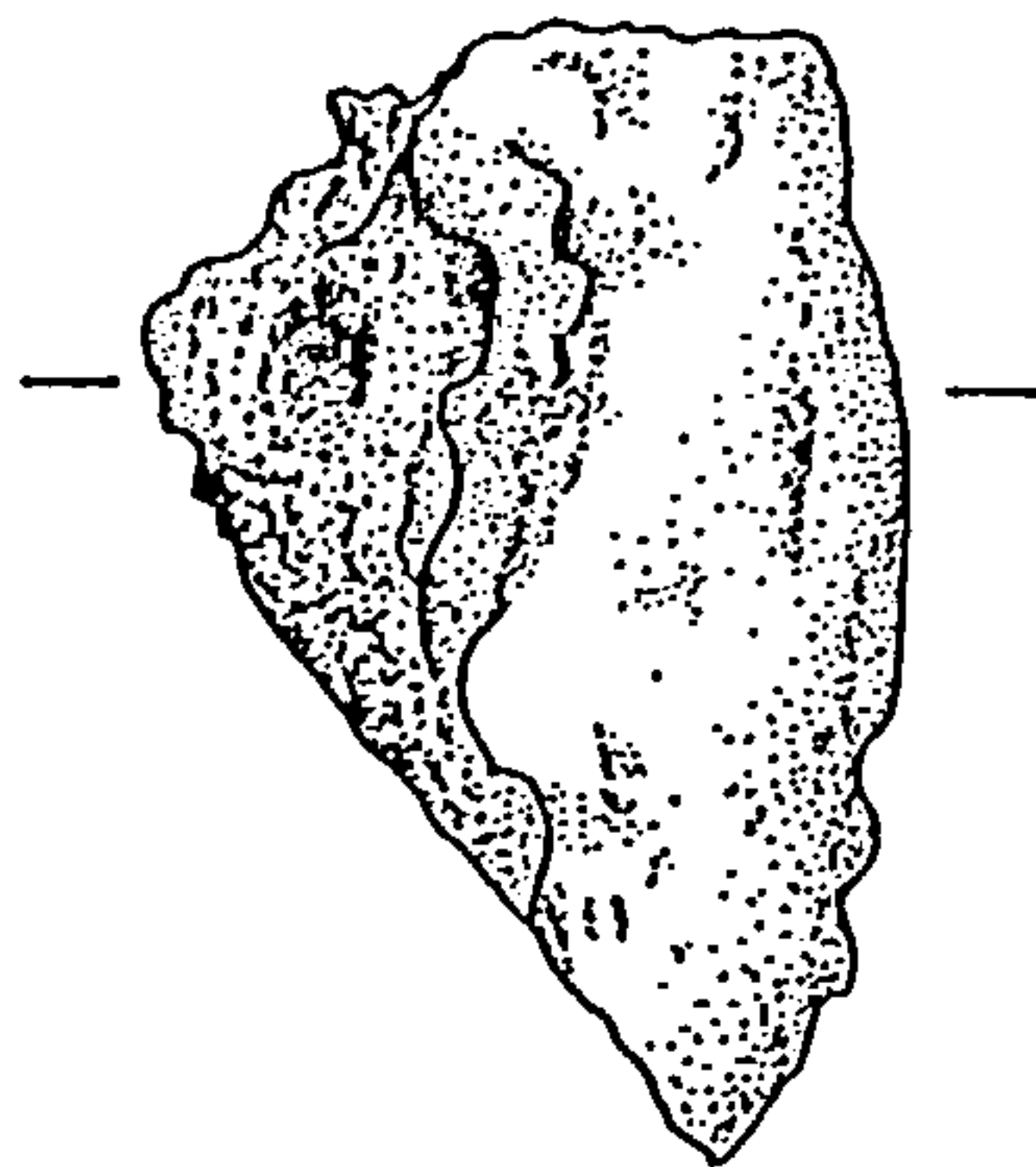
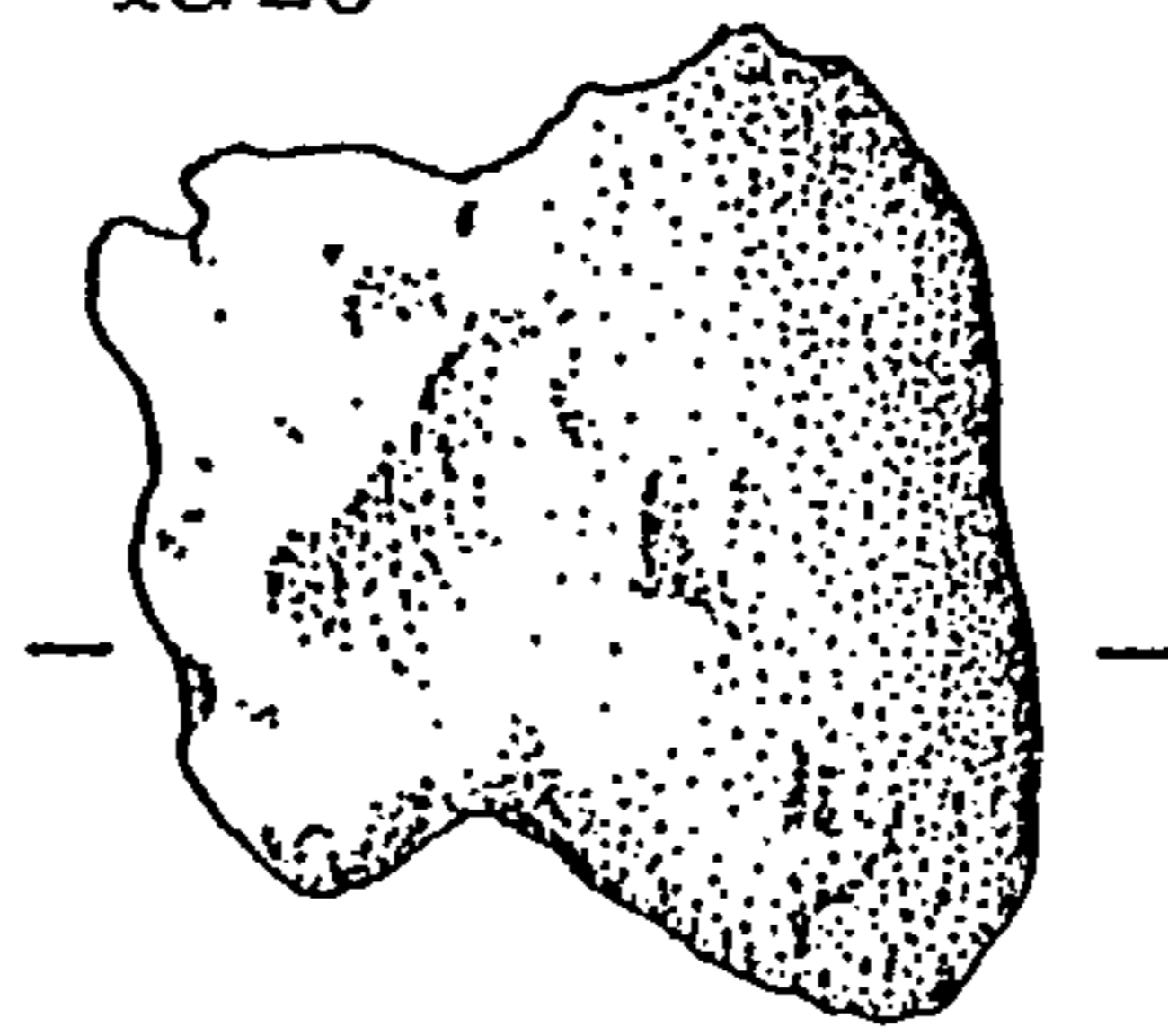


Fig. 38 The Dartford Hoard (Ref. No. 18): Ingot Metal (ii)

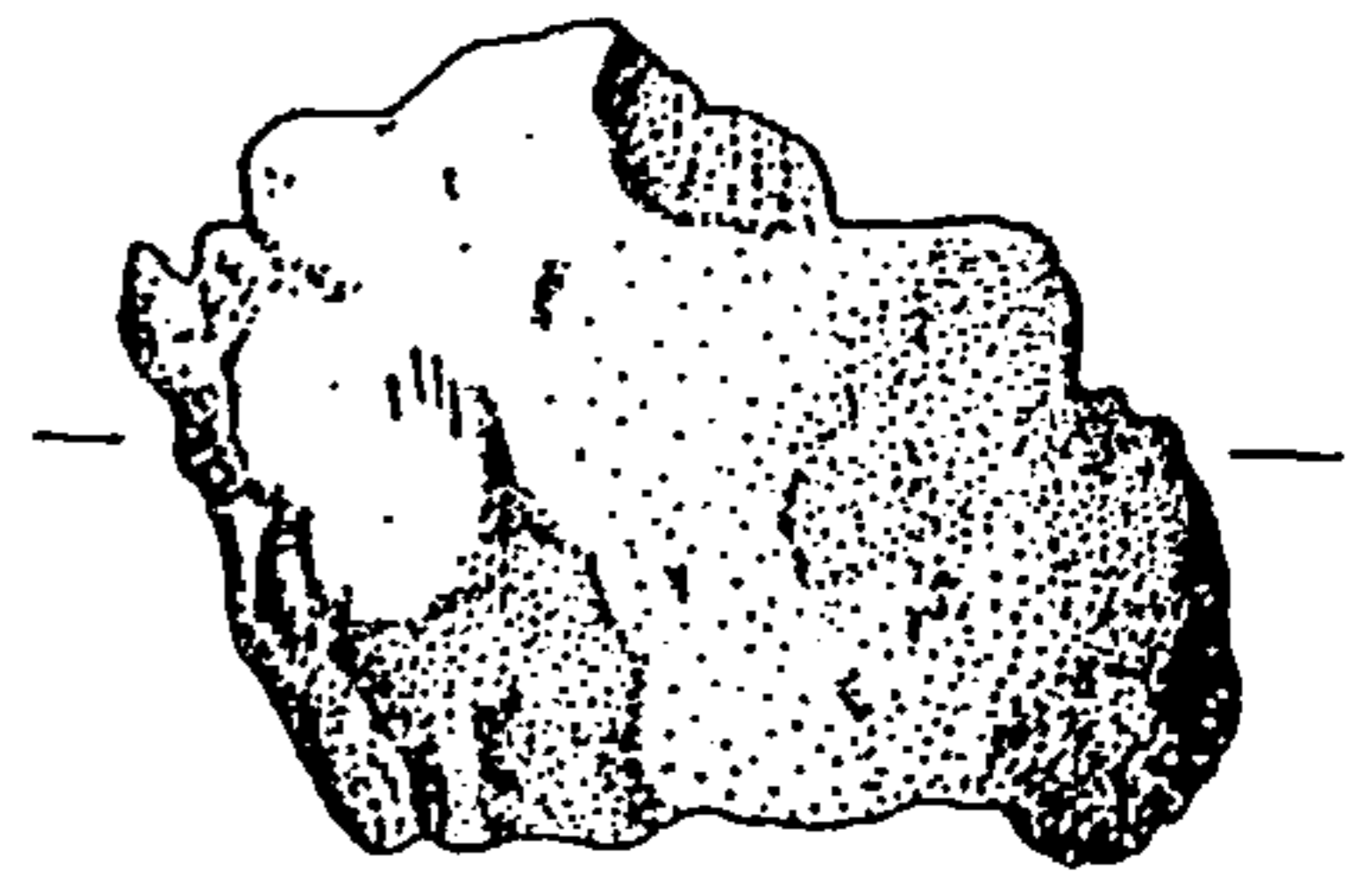
18/25



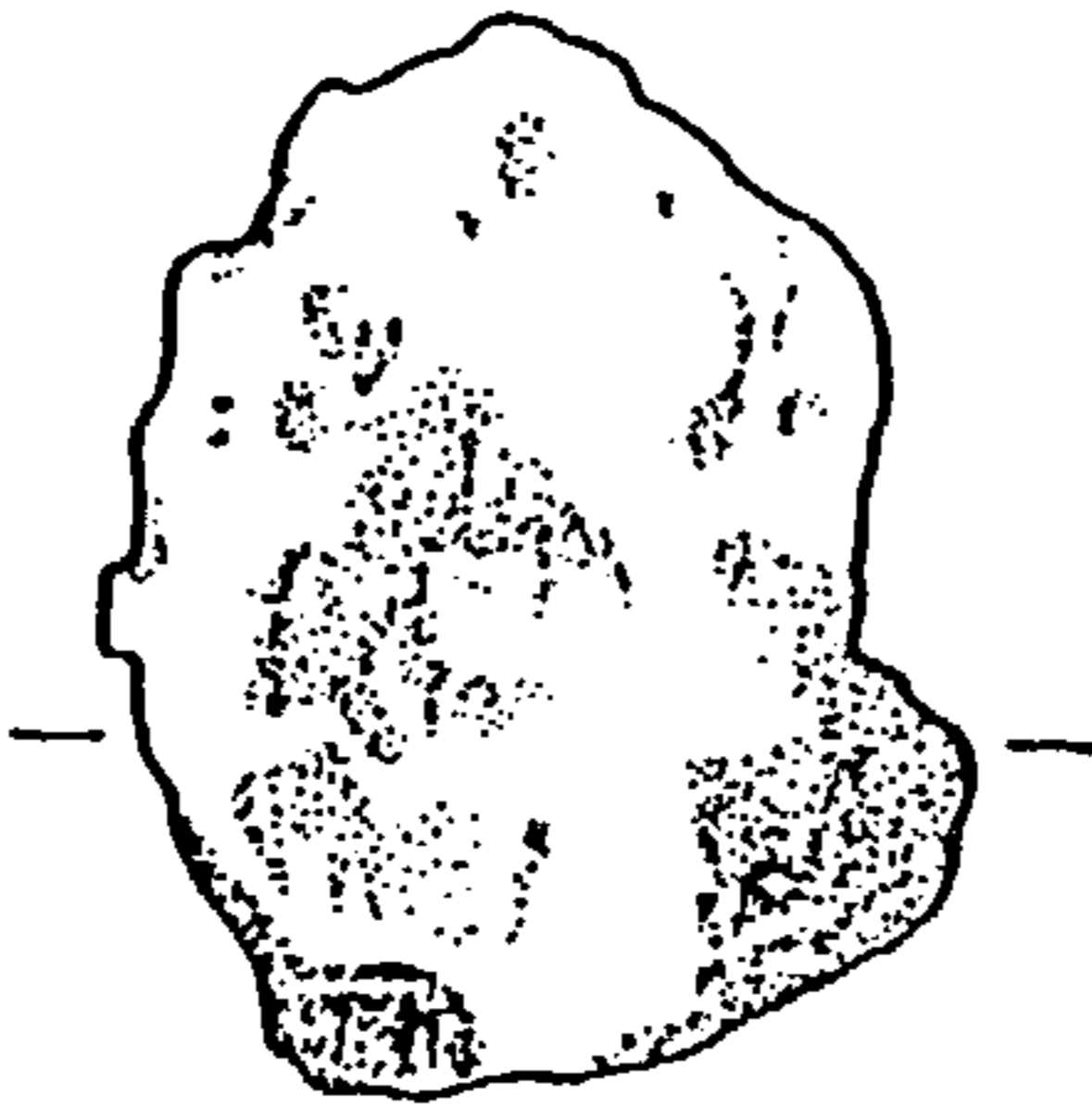
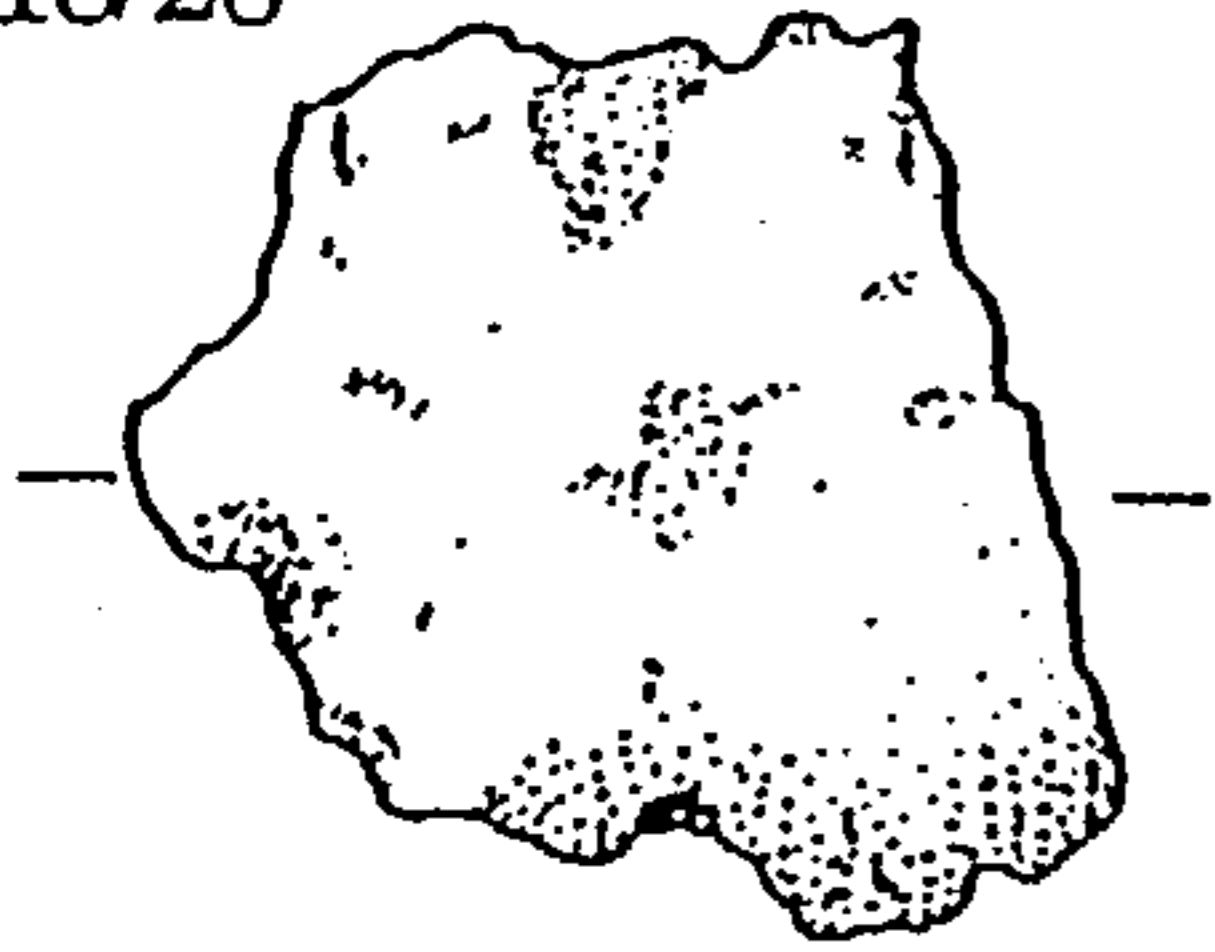
18/26



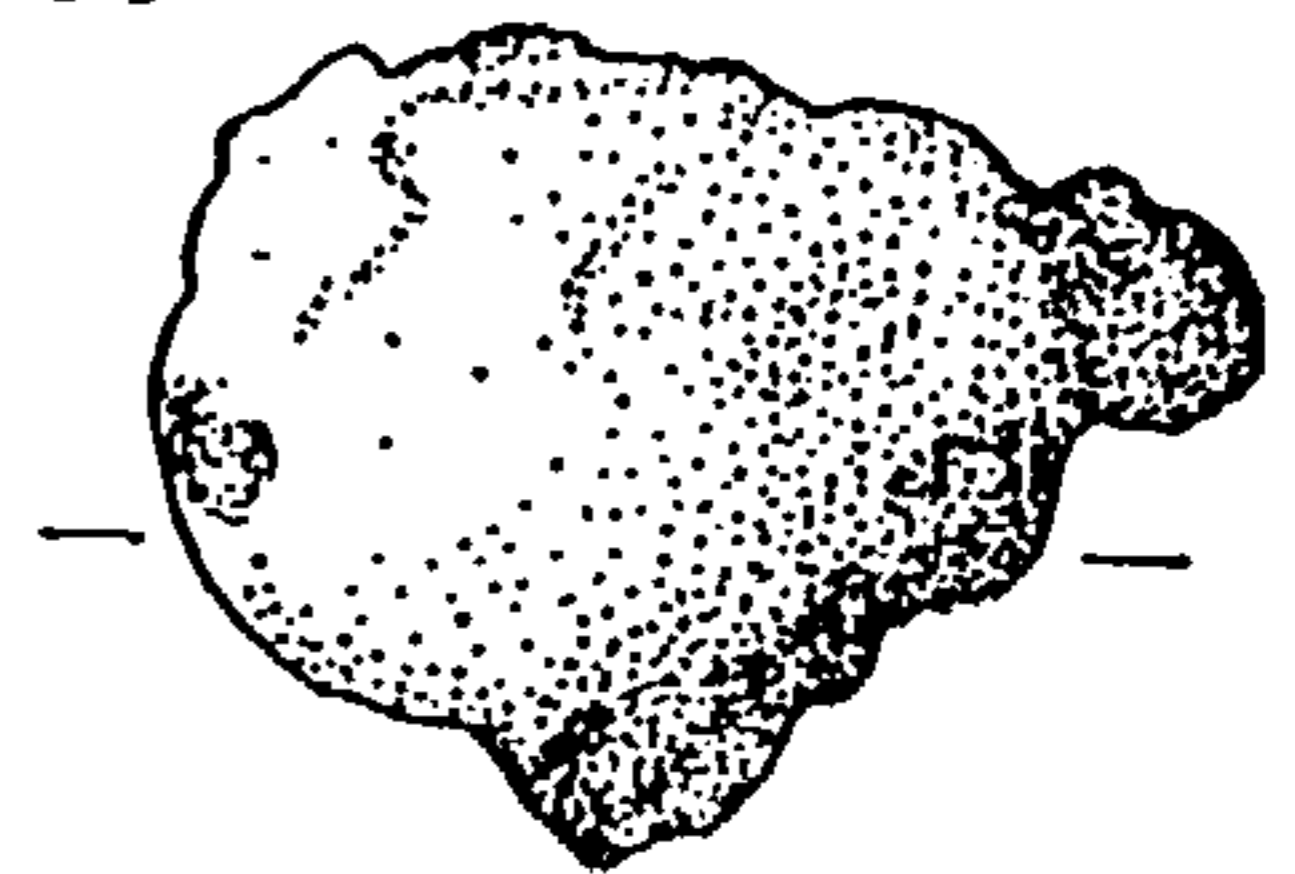
18/27



18/28

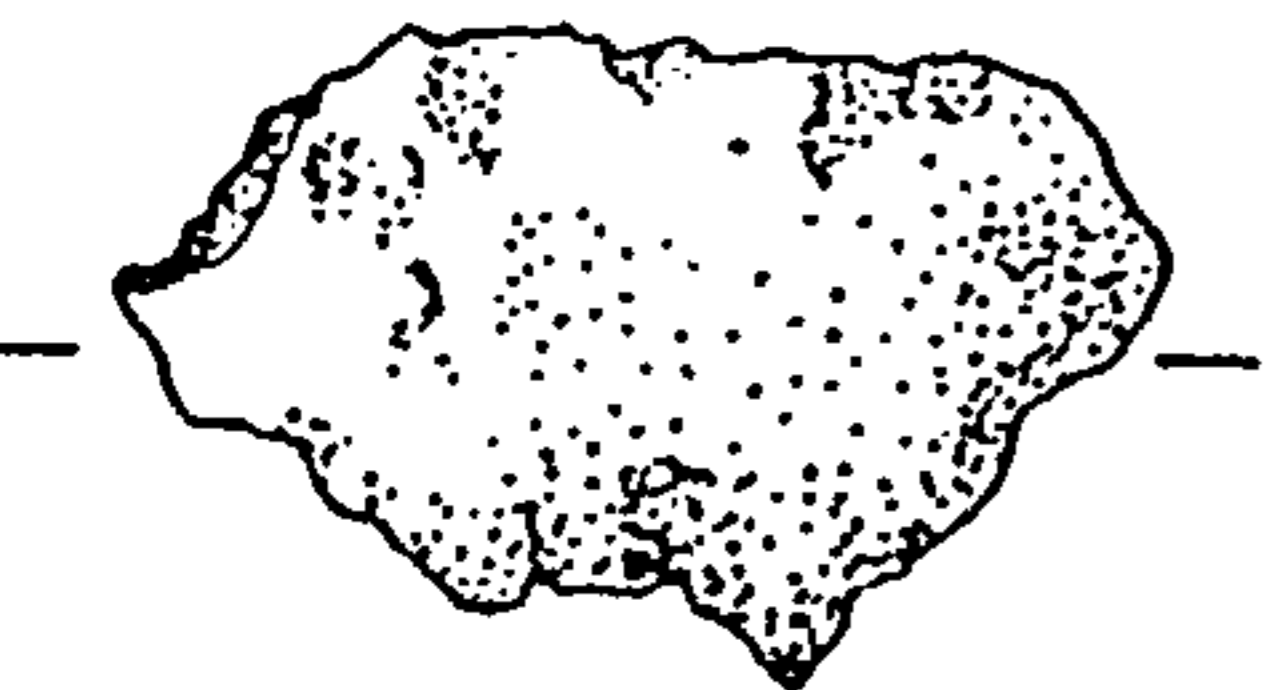


18/30



0 2cm

18/31



18/32



18/33



Fig. 39 The Dartford Hoard (Ref. No. 18): Ingot Metal (iii)

Minnis Bay (Ref. No. 19)

Grid Reference: TR 2849 6978.

Current Location: British Museum.

Context: The hoard was supposedly recovered from a gravel bank during the excavation of a Late Bronze Age settlement site (Worsfold, 1943), though doubt has recently been cast over the validity of this context (Champion, 1980).

Bibliography: Champion, T., 1980.
Jessup, R. F., 1930.
National Bronze Index.
Worsfold, F.H., 1943.

Contents:-

19/01 (Acc. No. 1961: 10-6: 19)

Description: Socketed axe of 'southern English' type, with three slightly diverging ribs hanging from the lower collar moulding.

Dimensions: Length: 119mm. Cutting edge: 62mm. Weight: 436.1g.

Patina: Much original bronze remains visible.

Manufacture: The uneven appearance of the mouth could result from a slight shortage of metal during casting. The feeders have been removed from the mouth, and the intervening seam has been trimmed and hammered. Over the body, the casting seams have been trimmed and flattened, but they still remain prominent, to a point c.10mm or so back from the cutting edge on either side, beyond which they have been obliterated. The seam has been smoothed down exceptionally well over the loop. Grinding marks are very clear, running vertically down the body, and horizontally above the cutting edge. There are some indications of small tool marks above the blade edge on one face (not illustrated).

Use: Some coarse diagonal striations are apparent across the surface. The edge has been expanded, and though it seems slightly chipped and burred in a few places it still seems usable.

Reduction: Some chisel marks are visible around the mouth.

19/02 (Acc. No. 1961: 10-6: 16)

Description: Socketed axe of 'southern English' type, with three parallel ribs on either face.

Dimensions: Length: 102mm. Cutting edge: 55mm.

Patina: Some patches of encrustation are apparent near the cutting edge, but otherwise details are good.

Manufacture: Stumps of the feeders remain visible at the mouth, and traces of the intervening seam are present here, too. Elsewhere, over the body, the seams have been flattened, but they still remain prominent over much of their length on either side. There are indications of vertical grinding marks on the lower body, and diagonal grinding marks are also visible in places.

Use: The blade is well-expanded, and appears to have been unevenly worn.

Reduction: Some blunt marks on the body, perhaps made by a trunnion chisel, may be linked to this process, perhaps having resulted from an attempt to dislodge the axehead from a tightly wedged haft.

19/03 (Acc. No. 1961: 10-6: 12)

Description: Socketed axe of 'southern English' type, with three ribs on either face. The loop does not amalgamate with the lower collar moulding in this example.

Dimensions: Length: 102mm. Cutting edge: 55mm. Weight: 294.7g.

Patina: Original bronze showing in places, with some black patches evident.

Manufacture: The collar is very uneven in appearance, through an inadequate amount of metal having been poured into the mould during casting. The object shows a pit in the bronze on one face, but there are no indications of any other casting defects. Stumps of the feeders are still evident at the mouth, while the casting seams on the body have been largely flattened. They have been obliterated over the loop, and below a point c. 10mm from the cutting edge on either side. Some vertical grinding marks run down the body in places, and

hammer indents are visible on one side over the cutting edge (not illustrated). The blade has been well expanded.

Use: The blade is notched and burred in places.

Reduction: Some chisel marks around the mouth may be related to the removal of the haft.

19/04 (Acc. No. 1961: 10-6: 17)

Description: Socketed axe, heavy in appearance, with 4 ribs apparent on either face, and with an additional rib defining the interfaces between the faces and upper/lower surfaces.

Dimensions: Length: 110mm. Cutting edge: 59mm. Weight: 414.7g.

Patina: Much original bronze remains visible. Some greyish patches are apparent around the loop, but the detail is mostly excellent.

Manufacture: The seams have been hammered over around the mouth to form a slightly overhanging lip. Over the body, the upper seam is obtrusive over much of its length, and its pronounced nature may result at least partly from mismatched valves. On the underside, the seam has been obliterated over the loop, but remains visible elsewhere. The blade has been expanded, with signs of hammering over the cutting edge. Vertical striations are clearly visible between the ribs, and vertical and diagonal marks are also visible further down the body in places (not illustrated).

Use: The squat appearance to the piece may indicate that it has already endured much resharpening. Its cutting edge is notched and burred in places, but over much of its length it remains sharp.

Reduction: There are possible notches on the loop and also in the vicinity of the collar, and these may be linked with the removal of the material that bound the axehead to its haft.

19/05 (Acc. No. 1961: 10-6: 20)

Description: Socketed axe, of diminutive proportions, with three ribs on either face, and a further rib defining the interface between each face and the upper/lower surfaces:

Dimensions: Length: 54mm. Cutting edge: 37mm. Weight: 83.5g.

Patina: Mostly original bronze with some sooty black deposits.

Manufacture: The seam has been almost completely removed around the mouth. The upper seam has been flattened over the body, remaining visible and slightly obtrusive, but has been obliterated from two-thirds of the way down the body to the cutting edge. The underside is similar, but here it has been completely obliterated over the loop. There are no visible indications of grinding marks. The blade is widely expanded, being almost crescentic in appearance, and there are indications of hammering between the body and the cutting edge.

Use: The cutting edge is blunt and notched along its length.

Reduction: The axehead is complete and there is no evidence relating to this process.

19/06 (Acc. No. 1961: 10-6: 18)

Description: Socketed axe of 'southern English' type, with 4 ribs on either face

Dimensions: Length: 118mm. Cutting edge: 56mm. Weight: 381.0g.

Patina: Much of the original bronze remains, although pale green patches of corrosion are apparent in places.

Manufacture: Two prominent casting flaws are evident. The first lies beneath the loop (illustrated), while the second consists of two adjacent gaps on the top surface. The loop seems slightly misshapen, and the mouth is uneven, indicating a shortage of metal in casting. A rounded notch in the blade may also indicate another flaw. The feeders have been removed at the mouth, and have been virtually obliterated. Over the body, the seams have been flattened, but they remain visible right down to the cutting edge, though the lower seam has been more extensively flattened over the loop. Coarse vertical grinding marks are visible on the blade over both faces, and in addition there are diagonal examples on one face only (not illustrated). The lower body and blade show signs of fine hammer working, and there is a slight bevel visible along the cutting edge.

Use: The blade still seems sharp, with some slight chipping apparent in places, and a marked notch at one end.

Reduction: Some notches on the loop may result from the removal of the binding material which attached the axehead to the haft.

19/07 (Acc. No. 1961: 10-6: 11)

Description: Socketed axe, of 'south-eastern' type, with a wing-decorated variant comprising two angular wings flanking a central saltire.

Dimensions: Length: 114mm. Cutting edge: 48mm. Weight: 300.2g.

Patina: Original bronze, but pitted in appearance, with the detail obscured in places.

Manufacture: The casting seams and feeders have been completely removed from around the mouth. On the body, the seams have been flattened and ground, and the grinding marks remain visible in places. Over the last 10mm back from the cutting edge, however, the seams have been obliterated on both sides. Diagonal grinding marks are visible below the area of decoration, and also in the furrows which define the decoration. The blade is crescentic, with hollows apparent over the corners of the blade.

Use: The cutting edge is very blunt, and is badly notched and also burred in places. Its broad crescentic shape also suggests that it has been resharpened, perhaps on more than one occasion. The isolated striations which run down the body may result from use-related damage.

Reduction: Some possible hammer marks around the top moulding could have been inflicted during the removal of the axehead from a tightly wedged haft.

19/08 (Acc. No. 1961: 10-6: 15)

Description: Socketed axe, of undecorated 'south-eastern' type.

Dimensions: Length: 103mm. Cutting edge: 35mm. Weight: 190.4g.

Patina: Some bronze has been revealed in those places where the dense, olive-brown patina has flaked away. Details are better on the side not illustrated.

Manufacture: The feeders have been removed from the mouth, and the intervening seam has been trimmed and flattened here. On both sides of the axehead, the seams are virtually invisible in the immediate vicinity of the cutting edge, but elsewhere they remain prominent, though the lower seam has been hammered smooth over the loop. There are indications of vertical grinding marks on both faces, and diagonal grinding marks on the body, and traces of horizontal grinding marks above the cutting edge (not illustrated). The cutting edge appears narrow, but has been expanded, and a slight bevel is just visible along its length.

Use: A large crack crosses one face, and this is associated with a distorted and slightly swollen appearance to the section of the upper body. This damage is likely to be use-related, as the metal has been pushed outwards, and not crushed inwards, which might be expected had the piece been broken during the removal of the haft. The cutting edge is very chipped, and where it remains intact it seems blunt. Uneven wear is evident, but the narrow shape of the blade suggests that the object was never resharpened, perhaps on account of the cracking. The reason for this breakage is a mystery, however, as there are no indications of wall weakness caused by core misalignment.

Reduction: A cluster of tiny chisel marks are visible on the interface between the top surface and one face. These may be linked with the removal of the material that bound the axehead to its haft.

19/09 (Acc. No. 1961: 10-6: 14)

Description: Socketed axe, of undecorated 'south-eastern' type, with two ribs running down the interior.

Dimensions: Length: 92mm. Cutting edge: 52mm. Weight: 199.0g.

Patina: Much of the original bronze remains visible on one side, with some patches of flaky pale green corrosion product. The other side is completely obscured by a coating of pitted pale green patina.

Manufacture: The stump of one feeder remains, but elsewhere all other feeders and their intervening seam have been obliterated from the mouth. Over the body, the seams have been trimmed and flattened, but still remain visible, though they have been virtually obliterated over the loop. There are vertical grinding marks visible on the body, and horizontal examples present above the cutting edge. Traces of fine hammering can be seen over the cutting edge, which has a rather crescentic appearance.

Use: A slight crack is apparent in the mouth, and this may be use-related damage. The blade shows signs of resharpening, with faint hollows visible over either corner. The cutting edge is now badly burred and chipped, with none of the original edge surviving.

Reduction: Some notches inside the mouth of the object could have resulted from the removal of the haft, although it is possible that they were caused during the removal of the clay core.

19/10 (Acc. No. 1961: 10-6:13)

Description: Socketed axe of unusual form. The top moulding is very heavy in appearance, and leads into a large, misshapen loop. Below this are an additional three collar mouldings. The body is faceted in appearance, with a rounded rectangular section.

Dimensions: Length: 101mm. Cutting edge: 41mm. Weight: 248.1g.

Patina: Much of the original bronze colour remains visible, with some greyish-green patches in places.

Manufacture: Vestiges of the feeders remain visible on the mouth, but the intervening seam has been obliterated. On the body, the upper seam has been trimmed and flattened over much of its length, but remains prominent over the collar mouldings. The lower seam is still prominent, however, especially between the loop and the mouth, and the body of the axe inside the area of the loop shows similar traces, though attempts seem to have been made to flatten this to some extent. Hammer indents are evident on the facets between the faces and their adjacent upper and lower surfaces, and hammering is also present where the axehead narrows above the collar mouldings. Diagonal striations are visible over the piece, and there are may also become faint horizontal grinding marks apparent above the cutting edge (not illustrated), but these are unclear. The blade has been widely expanded.

Use: Isolated striations are visible on the surface, and these could be use-related. The edge seems blunt and notched in places.

Reduction: The axehead is complete and there is no evidence pertaining to this process.

19/11 (Acc. No. 1961: 10-6: 76)

Description: Blade and lower body from a socketed axe of faceted type.

Dimensions: Length (maximum): 80mm. Cutting edge: 49mm. Weight: 127.5g.

Patina: Thick, dark olive. Details obscured.

Manufacture: The casting seams have been completely removed from either side, and the blade is well-expanded.

Use: The cutting edge is blunt along its length and is chipped and notched in places.

Reduction: The object has been hammered inwards on both faces at the break, and the section is now much distorted as a result.

19/12 (Acc. No. 1961: 10-6: 24)

Description: Blade and lower body of socketed axe.

Dimensions: Length (maximum): 72mm. Cutting edge: 37mm. Weight: 124.4g.

Patina: Some bronze showing, but the piece shows extensive areas covered with pale green/mottled brown patina. There are also patches of a sooty black deposit. Details obscured.

Manufacture: One wall seems markedly thinner, indicating a misaligned core. The seam has been virtually obliterated over one side, while on the other it has been trimmed and flattened to some extent, though it remains prominent. On both sides, the seams have been completely removed towards the cutting edge from a point measuring roughly 25mm up the blade. The cutting edge has been widely expanded.

Use: None of the original cutting edge survives, the edge being very blunt in appearance with one corner now missing.

Reduction: One face - associated with the thinner wall - has been pushed inwards at the break, and some hammer-marks are apparent here in association with this crushing. No indications of hammering or deformation can be seen on the other face, though. Both faces show tool marks. These are broad blunt notches as opposed to the small, sharp chisel marks that are often seen, suggesting the use of a larger heavier implement, perhaps even another axe.

19/13 (Acc. No. 1961:10-6:23)

Description: Long mouth fragment of socketed axe, probably of 'south-eastern' type.

Dimensions: Length (maximum): 71mm. Weight: 37.9g.

Patina: Thick olive, with patches of dark or pale green, and with occasional bronze showing. Details obscured.

Manufacture: A tiny dip on the collar seems to represent a minor casting flaw, and the wall seems thin here, suggesting core misalignment. The casting seam around the mouth has been completely removed, and no other manufacturing details cannot be seen.

Use: Impossible to determine.

Reduction: Slight distortion is apparent in the section at the break, and this is likely to have resulted from hammering. One possible hammer indent can be seen here.

19/14 (Acc. No. 1961:?)

Description: Small mouth fragment of socketed axe, probably of 'south-eastern' type.

Dimensions: Length (maximum): 40mm.

Manufacture: No traces of the casting seam survive around the mouth, and no other evidence relating to this process can be identified.

Use: Impossible to determine.

Reduction: There is no evidence relating to this process. Breakage may have inflicted deliberately, or it may have been use-related.

19/15 (Acc. No. 1961:10-6:78)

Description: Fragmentary upper body of ribbed socketed axe.

Dimensions: Length (maximum): 33mm. Weight: 64.3g.

Patina: Rough olive colour, with pale green and rust-coloured patches.

Manufacture: The mouth seems very rough, with an almost concave appearance, which suggests that insufficient molten metal was poured into the mould during casting. There is one possible stump of a feeder jet visible, and traces of the seam remain only over the collar.

Use: Impossible to determine.

Reduction: The section shows distortion, and hammer marks are clearly visible on the collar, causing the faces to be pushed inwards. Hammering is not so evident near the lower break, but there are some possible examples, especially on the side not illustrated. This side also shows deformation of collar moulding as a result of hammering.

19/16 (Acc. No. 1961: 10-6: 22)

Description: Blade fragment of socketed axe.

Dimensions: Length (maximum): 50mm. Cutting edge: 47mm. Weight: 190.6g.

Patina: Rough pale green, with some bronze showing.

Manufacture: The axehead has been discarded in virtually as-cast condition - the casting seam remains prominent near the cutting edge, and also runs along the cutting edge itself. Some effort has been made to prepare the piece for use, though, as the surface of the casting has a finely dimpled surface, indicating that it has been subject to fine hammering.

Use: Unused.

Reduction: No distortion of the section is evident at the break, but the walls are very thick in section here, and hammering is therefore unlikely to have caused much distortion. It is possible that some of the hammer indents noted above are linked with this stage of the object's use-cycle.

19/17 (Acc. No. 1961: 10-6: ?)

Description: Blade and lower body of a 'socketed axe-like chisel'.

Dimensions: Length (maximum): 68mm. Cutting edge: 43mm.

Patina: Dull bronze colour, with some sooty black patches. Details excellent.

Manufacture: The surface of the casting has been subject to careful hammering. The cutting edge is well-expanded, with a fine bevel running along its length, and there are indications of horizontal grinding marks above the cutting edge, and small diagonal grinding marks visible along the length of the bevel.

Use: The piece seems to have seen little use, the edge remaining sharp and unblemished.

Reduction: The object has been roughly broken across the centre of the blade, but there is no evidence directly linked with this.

19/18(Acc. No. 1961: 10-6: 77)

Description: Blade from socketed chisel, fairly slender in shape.

Dimensions: Length (maximum): 55mm. Cutting edge: 41mm. Weight: 45.3g.

Patina: Rough, thick, dark olive/black, with patches of pale brown, black and pale green evident. Details obscured.

Manufacture: One wall is very thin in section, indicating core misalignment. The casting seams have been obliterated, and the blade appears well-expanded.

Use: The blade is in fine condition, with no notches or chips evident along its length.

Reduction: Some traces of hammering are apparent at the break, and this has caused crushing of the socket. Some possible punch or chisel marks are also visible here.

19/19 (Acc. No. 1961: 10-6: 31)

Description: Socketed chisel.

Dimensions: Length: 68mm. Cutting edge: 34mm. Weight: 44.3g.

Patina: The original bronze colour remains, with some black sooty deposits in places.

Manufacture: The casting seams have been neatly removed all over the piece. The upper body appears rough, as if as-cast, but above the cutting edge fine hammering is apparent. The blade is well-expanded, and there are horizontal grinding marks running above cutting edge. There is some pitting of the bronze on the body, which might indicate that the casting is of inferior quality, but the piece is otherwise fine.

Use: The blade seems to be in fine condition. It appears chipped in places under examination with a hand-lens, but this damage may be linked with later build-up and subsequent flaking of the corrosion product.

Reduction: The object is complete, with no evidence relating to this process.

19/20 (Acc. No. 1961: 10-6: 25)

Description: Winged axe.

Dimensions: Length: 151mm. Cutting edge: 38mm. Weight: 424.6g.

Patina: The original bronze colour shows over much of the piece.

Manufacture: A slight notch in one of the wings seems to be a minor casting flaw. The casting seams have been virtually obliterated over the entire piece. At one end of the loop, there are possible chisel marks which may be linked with this process, as they focus upon the area where the seam would once have been. The wings have been finely hammered, and this hammering probably results from the wrapping of the wings around a haft in order to secure the axehead before use. The blade has a faintly undulating appearance to the surface which suggests that it has been subject to careful hammering, and there are some horizontal grinding marks above the cutting edge.

Use: The cutting edge, though narrow, has bevels above the corners which might indicate resharpening. It is now in reasonable condition, with one small notch missing from its length

Reduction: The object is complete, and there is no evidence relating to this process.

19/21 (Acc. No. 1961: 10-6: 26)

Description: Winged axe.

Dimensions: Length: 133mm. Cutting edge: 42mm. Weight: 349.8g.

Patina: Rough, mottled pale-green, with occasional patches of bronze colour showing through. Details obscured.

Manufacture: The casting seams have been virtually obliterated, with only a faint trace remaining visible on the upper surface. There are grinding marks on the lower wings and possible horizontal grinding marks just above the cutting edge, which is crescentic in appearance.

Use: The blade may have been resharpened. The cutting edge survives only in poor condition, and in the few places where it remains intact it is badly blunted. Both of the lower wings have broken, and this could be use-related damage.

Reduction: The breakage of the wings could have been deliberately inflicted during this process, but no evidence survives which can lend strong support to this suggestion.

19/22 (Acc. No. 1961: 10-6: 27)

Description: Winged axe, with tang-like protrusion on butt.

Dimensions: Length: 155mm. Cutting edge: 33mm. Weight: 324.0g.

Patina: Original bronze colour remains, although the interior of the wings and the area towards the butt has a greyish-green patina.

Manufacture: The casting seams have been obliterated over much of the piece, but the lower seam remains visible over the loop, though it has been flattened here. Over the butt, the seam remains very pronounced, as if deliberately retained. The loop is very thin and has a waisted appearance, which suggests that the molten metal failed to flow properly here during casting. There are horizontal grinding marks visible above the cutting edge, and some vertical striations running down the blade.

Use: The cutting edge is expanded, and remains sharp over much of its length.

Reduction: One lower wing has broken off, though there is no obvious hammering at the break which would indicate deliberate destruction.

19/23 (Acc. No. 1981: 10-6: 28(a))

Description: Butt fragment of winged axe, which supposedly adjoins 1961: 10-6: 28 (b). The two pieces do not join exactly, however, which casts doubt on the possibility that they originated from the same object.

Dimensions: Length (maximum): 75mm. Weight: 112.2g.

Patina: Mottled rough pale green/olive/black with occasional patches of bronze showing. Details much obscured.

Manufacture: The casting seams have been completely removed from the upper surface. Vestigial traces of the seam remain on the underside, though over the loop all traces have been obliterated. There is possible evidence of fine hammering on the lower wings, but it is hard to be confident about this as the patina is rough and uneven here.

Use: One of the lower wings has been broken and the butt has been chipped.

Reduction: There are some possible hammer indents near the break which seem likely to be linked with this process, but these are unclear, and these marks may have been linked with manufacture. They are most pronounced on the side not illustrated.

19/24 (Acc. No. 1961: 10-6: 28 (b))

Description: Blade fragment of winged axe or adze, perhaps adjoining 19/23 (See above).

Dimensions: Length (maximum): 87mm. Cutting edge: 38mm. Weight: 228.8g.

Patina: Covered with a thick covering of olive corrosion product. Details much obscured.

Manufacture: The casting seams have largely been obliterated, and there are some grinding marks apparent on the underside.

Use: The edge seems relatively sharp, though it has been chipped extensively along its length. This damage may have resulted from the loss of flaking corrosion product.

Reduction: There are no clear indications of deliberate breakage, except for a slightly distorted area on the upper surface, near where the wings would once have emerged. The whole blade, however, appears distorted. While the blade has the appearance of a winged adze, the triangular hollows which mark the junction between of the body and the blade section are in the wrong place. Perhaps this distortion was therefore caused by the hammering that ultimately fragmented the object.

19/25 (Acc. No. 1961: 10-6: 32)

Description: Socketed mortising chisel.

Dimensions: Length: 97mm. Weight: 39.7g.

Patina: Thick, rather rough, brownish olive, with some bronze patches. Details obscured.

Manufacture: No traces of any casting seams remain, and no other evidence can be linked with this process.

Use: The object appears to be in perfect condition, and, though prepared for use, may never have been used.

Reduction: The object is complete and there is no evidence pertaining to this process.

19/26 (Acc. No. 1961: 10-6: 79)

Description: Socketed mortising chisel.

Dimensions: Length: 113mm. Weight: 74.8g.

Patina: Rough bronze finish, with some encrustation in places. The object is rather messy in appearance, and may have been subject to chemical stripping of the corrosion products.

Manufacture: The junction between the mould valves can be seen as a slight furrow, with no raised seams surviving. The piece is otherwise well-finished. Diagonal grinding marks are visible on both sides and on one face of the blade, and additional horizontal grinding marks can be seen on one of the faces.

Use: The piece is in good condition and may have seen little if any use.

Reduction: The object is complete, with no evidence pertaining to this process.

19/27 (Acc. No. 1961: 10-6: 80)

Description: Socketed punch, with two concentric grooves present just below the collar. The blade is square in section, tapering to a flat edge at its tip.

Dimensions: Length: 103mm. Weight: 61.9g.

Patina: Rough, flaking appearance to piece.

Manufacture: The piece has been beautifully finished, with all the seams removed. Horizontal grinding marks are visible across the blade on two opposing sides (see illustration).

Use: The tip is notched and broken.

Reduction: The object is complete and there is no evidence pertaining to this process.

19/28 (Acc. No. 1961: 10-6: 29)

Description: Socketed gouge, slight collar moulding visible at the mouth.

Dimensions: Length: 87mm. Weight: 61.5g.

Patina: Original bronze colour shows over much of piece.

Manufacture: The seams have been neatly removed around the mouth and the sides of the object. Vertical striations run down the interior of the blade, and there is fine hammer working apparent near the edge.

Use: The edge seems fine and sharp, and the object remains in good condition.

Reduction: The object is complete and there is no evidence pertaining to this process.

19/29 (Acc. No. 1961: 10-6: 30)

Description: Socketed gouge, a collar moulding faintly visible in places around mouth.

Dimensions: Length: 83mm. Weight: 74.5g.

Patina: Rough olive in colour, with some bronze showing, but detail much obscured.

Manufacture: The casting seams have been largely obliterated, with only faint vestigial traces surviving on the sides. Vertical striations are visible, running down the interior of the blade.

Use: The edge seems sharp and fine, and the object appears to remain in perfect condition. It is likely that the gouge saw little - if any - use.

Reduction: The object is complete, with no evidence pertaining to this process.

19/30 (Acc. No. 1961: 10-6: 34)

Description: Knobbed, tanged sickle.

Dimensions: Length: 165mm. Weight: 95.1g.

Patina: Some bronze patches, the remainder being rough grey green.

Manufacture: There are some possible horizontal grinding marks visible along the cutting edge, with similar marks apparent on the upper edge of the piece.

Use: Some small notches can be seen along the cutting edge, but the piece basically appears to be in good condition.

Reduction: The object is complete, with no evidence pertaining to this process.

19/31 (Acc. No. 1961: 10-6: 81)

Description: Large portion of sickle blade, with two raised ribs running parallel to the uppermost edge. This fragment adjoins 19/32.

Dimensions: Length (maximum): 118mm. Weight: 58.2g.

Patina: Very rough grey-green. Details much obscured.

Manufacture: There are some possible vertical grinding marks running perpendicular to the cutting edge and other similar examples associated with the upper edge (not illustrated). These are not at all clear and must remain questionable.

Use: Some notches are present on the edge, and one stretch, measuring c. 20mm in length,

has none of the original cutting edge surviving.

Reduction: There is a faintly bowed appearance to the profile of the piece, though no hammering can be seen in association. The piece has probably been snapped into pieces.

19/32 (Acc. No. 1961: 10-6: 35)

Description: Butt fragment of sickle blade, with knobbed tang, and two raised ribs running along the topmost edge. This fragment adjoins 19/31.

Dimensions: Length (maximum): 59mm. Weight: 45.2g.

Patina: Rough grey-green with sooty bloom over the surface. Details obscured.

Manufacture: It is difficult to make out any details on this example. There are possible grinding marks on the lower edge of the blade, but these must remain tenuous.

Use: The cutting edge is in good condition, with no chips or notches missing.

Reduction: No hammering can be seen in association with the break. The slight distortion to the profile seen in 19/31 suggests that the sickle was snapped in two by hand.

19/33 (Acc. No. 1961: 10-6: 36)

Description: Incomplete sickle blade, with a single raised rib running along the top edge.

Dimensions: Length (maximum): 104mm. Weight: 43.4g.

Patina: Rough olive, with patches of whitish encrustation present which obscures much detail.

Manufacture: No details can be linked with this stage of the object's life - all visible striations appear to be associated with modern damage.

Use: The cutting edge is in poor condition, appearing broken and chipped over much of its length, although its appearance has undoubtedly been exaggerated by the recent build-up and loss of corrosion products.

Reduction: The profile of the piece appears distorted, and there are some rough hammer indents on the upper blade. These may appear more severe than they originally would have been on account of the corrosion buildup, though.

19/34 (Acc. No. 1961: 10-6: 64)

Description: Fragment of 'Thorndon' type socketed knife, comprising socket and part of blade. Two incised lines are clearly visible on one side of the socket (illustrated), though one of these is missing over a considerable extent on the other side.

Dimensions: Length (maximum): 36mm. Weight: 24.2g.

Patina: Rough pale green, with patches of bronze showing through. Details obscured.

Manufacture: All the casting seams have been completely removed.

Use: The cutting edges seem fine and sharp. The absence of the decoration on one side may result from wear - the incised line is clearly absent, but patina buildup does not obscure the piece here.

Reduction: The section is distorted where the socket is broken. Here, the metal has been pushed inwards slightly, although no hammering can be seen in association with this damage. The blade shows no signs of either bending or hammering at the break.

19/35 (Acc. No. 1961: 10-6: 61)

Description: Fragment of sheet bronze with fragmentary rivet hole remaining. This piece is likely to be a fragment from the socket of a 'Thorndon' type socketed knife, and yet the thickness of the bronze seems insufficient.

Dimensions: Length (maximum): 23mm. Weight: 1.8g.

Patina: Grey green with olive patches. Soil or clay adheres to the interior.

Manufacture: If this piece did originally come from a socketed knife, then the core was clearly misaligned on account of the thinness of the metal. The rivet-hole has been punched through cleanly and appears well-finished, thus suggesting that the piece was prepared for use. There is also evidence of fine hammering across the surface of the piece.

Use: Difficult to determine. Where the rivet hole remains intact, it shows no indications of strain.

Reduction: No evidence can be linked with this process.

19/36 (Acc. No. 1961: 10-6: 10)

Description: Fragment of knife blade.

Dimensions: Length (maximum): 58mm. Weight: 10.4g.

Patina: Very rough and patchy appearance to the patina.

Manufacture: Some diagonal grinding marks are visible near the break, but no other evidence can be linked with this stage of the object's life-cycle.

Use: The edges are notched and the extreme tip is now missing. This damage is probably use-related.

Reduction: There are no signs of hammering near the break, and the profile shows no distortion. It seems likely that the blade was snapped into pieces.

19/37 (Acc. No. 1961: 10-6: 10)

Description: Socketed sword, with hollow-cast bronze hilt. The blade is leaf-shaped, and is very short in length - too short, in fact, to function as a conventional sword. Instead, it might be more appropriate to describe the object as a dagger or knife. There are faint ricasso notches apparent below the hilt, and the hilt itself has 6 rivet holes present.

Dimensions: Length: 368mm. Weight: 352.7g.

Patina: Rough bronze. In this example, the corrosion may have been stripped.

Manufacture: There are some vertical striations visible on the blade in places, and no traces of any casting seams survive.

Use: The blade is notched and chipped in a number of places along its extent. The rivet holes at the end of the hilt are strained on both sides, and another rivet hole appears to have been inserted to compensate for this damage. This has also ripped through, and it now adjoins the original.

Reduction: There are some hammer indents present near the hilt, and the section here is distorted. The profile of the blade has a faintly bowed appearance, though it remains complete and unbroken.

19/38 (Acc. No. 1961: 10-6: 2)

Description: Shoulders and upper blade of 'Ewart Park' type sword.

Dimensions: Length (maximum): 112mm. Weight: 141.0g.

Patina: Dense bronze-olive.

Manufacture: Some vertical grinding marks are visible in places, running down the blade. No traces of any casting seams survive..

Use: The cutting edge is missing over most of one side of the blade. On the other it appears to be in better condition, but is nonetheless notched in places and has one large piece broken out of it.

Reduction: The profile is straight, with no distortion, and there are no visible indications of hammering at either break.

19/39 (Acc. No. 1961: 10-6: 70)

Description: Fragment of sword tang.

Dimensions: Length (maximum): 65mm. Weight: 54.2g.

Patina: Rough pale green patches, overlying a basic thick olive patina.

Manufacture: No traces of any casting seams survive, and the rivet holes are clean. No other details can be seen.

Use: The object has broken across the lower rivet hole. The metal does not appear strained or distorted here, but since this was the weakest point of the casting, use-related damage seems likely.

Reduction: No evidence of deliberate destruction can be seen in this example.

19/40 (Acc. No. 1961: 10-6: 73)

Description: Blade fragment of 'Carp's Tongue' sword, with grooves defining the midrib.

Dimensions: Length (maximum): 43mm. Weight: 41.4g.

Patina: Golden-bronze colour, with some rough black patches and an opalescent sheen across the surface. The object appears to have undergone chemical treatment.

Manufacture: No details survive following the corrosion stripping.

Use: There are some notches on one blade edge, but the piece otherwise appears to remain in good condition.

Reduction: There is a bend in the profile, but there are no hammer indents to be seen in association.

19/41 (Acc. No. 1961: 10-6: 71)

Description: Blade fragment of 'Carp's Tongue' sword, with grooves defining the midrib.

Dimensions: Length (maximum): 63mm. Weight: 67.5g.

Patina: Dense olive, with some thick patches. Details largely obscured.

Manufacture: Little detail is now visible. Vertical grinding marks are apparent on the midrib, and on the interfaces between the midrib and the blade, and diagonal grinding marks are visible in places along the edges of the blade.

Use: The edges remain fairly sharp, but seem quite badly notched, and there are some deep grooves running across the midrib in places. The latter may be use-related.

Reduction: The profile is slightly distorted towards one of the breaks, but no clear indications of hammering are visible here. There is one possible hammer indent at one break (lowermost on illustration) on one face (not illustrated), and some more examples can be identified near the upper break (illustrated). However, these must remain problematic due to the nature of the corrosion product.

19/42 (Acc. No. 1961: 10-6: 72)

Description: Blade fragment of 'Carp's Tongue' sword, with grooves defining the midrib.

Dimensions: Length (maximum): 125mm. Weight: 155.8g.

Patina: Rusty brown in colour, with patches of green and black. No details are visible.

Manufacture: Nothing can be seen.

Use: The edges still appear sharp, though they are notched in places.

Reduction: The profile of the fragment shows signs of distortion. The metal appears strained at one of the breaks (pictured uppermost), due to the amount of bending suffered prior to fragmentation, and a faint hammer indentation can be seen in association with this. No similar indications are visible at the other break.

19/43 (Acc. No. 1961: 10-6: 5)

Description: Blade fragment of 'Carp's Tongue' sword, with grooves defining either side of the midrib.

Dimensions: Length (maximum): 64mm. Weight: 69.2g.

Patina: Much of the original bronze colour shows, but the surface is rough, suggesting that the corrosion may have been stripped from the piece.

Manufacture: The bronze appears pitted in places. This could indicate a poor quality casting, but may also have resulted from the removal of the corrosion products. There are also some vertical striations visible on the midrib.

Use: The edges are notched in a few places, but otherwise remain fine and sharp.

Reduction: The profile is distorted, but there is no visible evidence of hammering in association with either break.

19/44 (Acc. No. 1961: 10-6: 3)

Description: Blade tip from 'Carp's Tongue' type sword, with grooves defining the midrib.

Dimensions: Length (maximum): 89mm. Weight: 30.9g.

Patina: Original bronze colour shows, probably as a result of corrosion stripping.

Manufacture: Some horizontal grinding marks are visible on the blade. The surface of the casting is pitted, and while this may indicate a poor quality casting, it seems more likely to have resulted from the stripping of the corrosion.

Use: The edges seem sharp, but are notched in places.

Reduction: There is a slight bend to the profile, but there are no hammer indents associated with the break. However, it seems likely that much surface detail will have been lost following the removal of the corrosion products.

19/45 (Acc. No. 1961: 10-6: 6)

Description: Blade fragment of leaf-shaped sword, probably of 'Ewart Park' type.

Dimensions: Length (maximum): 53mm. Weight: 57.7g.

Patina: Rough grey-green in colour. Details obscured.

Manufacture: Some diagonal grinding marks are visible on the midrib.

Use: The edges seem fine over much of their length, but are notched in places.

Reduction: There is a marked bend to the profile, but there are no visible indications of hammering.

19/46 (Acc. No. 1961: 10-6: 74)

Description: Blade fragment of leaf-shaped sword, probably of 'Ewart Park' type.

Dimensions: Length (maximum): 69mm. Weight: 74.1g.

Patina: Rough rusty-brown colour, with black patches. It is impossible to see any details upon the surface.

Manufacture: There is no visible evidence which relates to this process.

Use: Where the cutting edges survive intact, they are very badly notched.

Reduction: There is a bend to the profile, but no hammer indents can be seen in association. This may be due in part to the poor condition of the surface, however.

19/47 (Acc. No. 1961: 10-6: 4)

Description: Blade tip from leaf-shaped sword, probably of 'Ewart Park' type.

Dimensions: Length (maximum): 66mm. Weight: 24.1g.

Patina: Much of the original bronze colour remains visible.

Manufacture: Some grinding marks can be seen running parallel with the blade edges.

Use: The cutting edges remain fine and sharp, though there are some small notches apparent along their length.

Reduction: The profile is slightly distorted, and there are some indications of hammering in association with the break.

19/48 (Acc. No. 1961: 10-6: 7)

Description: Purse-chape, with a single rivet hole on either side.

Dimensions: Width: 44mm. Depth: 23mm. Weight: 27.3g.

Patina: The original bronze remains visible, though there are some rougher areas present.

Manufacture: The object is well-finished, with no traces of any casting seams surviving.

Use: The rivet holes show no indications of any strain, though one face has been torn along its edge and this damage may be use-related.

Reduction: The distortion and the cracking along the edge of the chape may have resulted from the removal of the organic component of the scabbard as part of the reduction process.

19/49 (Acc. No. 1961: 10-6: 9)

Description: Fragment of socket from socketed spearhead.

Dimensions: Length (maximum): 44mm. Weight: 31.9g.

Patina: Some bronze remains visible, with pale green patches obscuring much of the detail.

Manufacture: There are some vertical grinding marks visible where the socket adjoins the blade, and no traces of any casting seams survive.

Use: Impossible to determine, though the rivet holes seem to be in good condition, with no signs of any strain apparent.

Reduction: There are traces of rough hammering on the socket, but there is no associated distortion to the section here.

19/50 (Acc. No. 1961: 10-6: 8)

Description: Leaf-shaped socketed spearhead. Beneath the level of the rivet holes, the socket is decorated with three concentric bands. In the space between these bands can be seen a series of tiny vertical impressions, giving a milled appearance around the socket.

Dimensions: Length: 122mm. Weight: 68.5g.

Patina: Much of the original bronze remains, with many details visible.

Manufacture: The casting has a pitted appearance over the midrib in places, which suggests a poor quality casting, and the rounded notch at the tip may indicate a casting defect. Virtually all evidence of the casting seams has been removed, though traces still remain around one of the rivet holes, and vertical grinding marks can be seen running down the length of the blade.

Use: Over much of its length the edge remains intact and sharp, though some notches are present. The decoration is less well-defined in places, which may indicate wear, and some striations which appear to date from antiquity may have resulted from use-related damage.

Reduction: There is a cluster of small tool marks apparent at one point, but these must be viewed with caution, as the bronze shows sign of recent damage here. Hammer indents are present halfway up the blade on both sides, though these are more numerous on the side not illustrated.

19/51 (Acc. No. 1961: 10-6: 65)

Description: Fragment of bracelet or armband, comprising a plain hollow tube, which narrows towards one end.

Dimensions: Length (maximum): 50mm. Weight: 23.3g.

Patina: Rough dark-olive, details obscured.

Manufacture: There is no evidence relating to this process.

Use: Impossible to determine.

Reduction: There is no evidence relating to this process.

19/52 (Acc. No. 1961: 10-6: 40)

Description: Fragment of hollow-cast bronze armband or bracelet, with an expanded foot terminal. The piece is decorated with a series of concentric incised lines over its length.

Dimensions: Length (maximum): 88mm. Weight: 54.5g.

Patina: Rough olive in colour, with details greatly obscured.

Manufacture: Some fine hammering is apparent along the side of the piece, and there are possible grinding marks here, too. The underside of the piece - which has a slot through which the core must have been removed - seems rough and uneven.

Use: There are no indications of excessive wear, the decoration remaining clearly visible along the length of the piece.

Reduction: There is no evidence relating to this process.

19/53 (Acc. No. 1961: 10-6: 43)

Description: Fragment of solid-cast bronze bracelet, with a small expanded foot terminal. Groups of opposed chevrons are used to create a repeated decoration along the length of the piece.

Dimensions: Length (maximum): 54mm. Weight: 19g.

Patina: Rough olive-bronze colour.

Manufacture: No traces of any casting seams remain, and there is no other evidence relating to this process.

Use: The piece does not appear to have been excessively worn, with the decoration remaining clear along its length.

Reduction: There are no traces of hammering near the break, though the piece now appears much distorted.

19/54 (Acc. No. 1961: 10-6: 83)

Description: Fragment of bronze bracelet with an expanded foot terminal. The piece is decorated with a repeated incised decoration, featuring alternating concentric lines and a herring-bone type device, quite roughly executed.

Dimensions: Length (maximum): 55mm. Weight: 20.7g.

Patina: Dense, reasonably smooth dark green patina, with some rough, grey-green patches that obscure the detail in places.

Manufacture: No casting seams remain visible, and some fine hammering is evident on the underside. This may be linked with the finishing process.

Use: There is no evidence of use-related damage or wear.

Reduction: Some rough hammer indents near the break may be linked with this stage of the object's life-cycle.

19/55 (Acc. No. 1961: 10-6: 41)

Description: Fragment of solid-cast bronze bracelet, undecorated, but with an expanded foot terminal.

Dimensions: Length (maximum): 67mm. Weight: 25.9g.

Patina: Rough, flaking grey patches, with sooty black patches in places.

Manufacture: All traces of the casting seams have been removed. There are possible indications of hammering in places, and some diagonal grinding marks are apparent, too.

Use: There is no evidence of use-related damage or wear.

Reduction: There is no evidence relating to this process.

19/56 (Acc. No. 1961: 10-6: 42)

Description: Fragment of solid-cast bronze bracelet, with a small expanded foot terminal. A series of shallow indentations runs along the length of the piece.

Dimensions: Length (maximum): 56mm. Weight: 17.1g.

Patina: Rough olive in colour, details reasonable.

Manufacture: Some hammer indents are visible on the sides of the bracelet. No casting seams remain visible, and there are no traces of grinding marks. This suggests that the hammering took place following grinding, or even that this latter process was never undertaken on this example.

Use: The decoration appears inconsistent, and this probably indicates wear.

Reduction: There is no evidence relating to this process.

19/57 (Acc. No. 10-6: 44)

Description: Fragment of solid-cast bronze bracelet, decorated with a series of incised lines. The section has a lenticular appearance, and the piece tapers towards the terminal.

Dimensions: Length (maximum): 75mm. Weight: 40.7g.

Patina: Much of the original bronze colour remains, and the details are clearly visible.

Manufacture: The casting seams have been completely removed, with some grinding marks visible upon the sides, and hammering apparent near the terminal.

Use: The pattern appears inconsistent, suggesting wear. The decoration may originally have encircled the piece, so its loss indicates extensive use. It originally crossed the entire extent of the upper surface, but much now appears faint. Though this seems to indicate wear, similar damage could have resulted from the removal of the seam.

Reduction: There is no evidence relating to this process.

19/58 (Acc. No. 1961: 10-6: 84)

Description: Fragment of solid-cast bronze bracelet, plain, and with an unexpanded terminal.

Dimensions: Length (maximum): 66mm. Weight: 17.2g.

Patina: Rough grey-green.

Manufacture: The casting seams are untrimmed, the piece unfinished.

Use: Unused.

Reduction: Hammering is visible in association with the break.

19/59 (Acc. No. 1961: 10-6: 63)

Description: Fragment of staple from cauldron or bucket, six ribs surviving.

Dimensions: Length (maximum): 72mm. Weight: 14.4g.

Patina: Much of the original bronze showing. Details reasonable.

Manufacture: Hammering is visible on the tab, with horizontal and diagonal grinding marks surviving here, too. There are, in addition, vertical grinding marks surviving in the hollows which separate the ribs.

Use: Grooves in the metal within the rim of the staple may indicate use-related wear.

Reduction: Some of the hammering apparent over the surface of the fragment may be linked with this process, but it seems a little too fine.

19/60 (Acc. No. 1961:10-6: 82)

Description: Fragment of hog-backed knife.

Dimensions: Length (maximum): 34mm. Weight: 30.7g.

Patina: Rough olive and pale green in colour.

Manufacture: Part of the uppermost seam remains visible, having been flattened, but not completely ground away. The slot appears to have been well-finished.

Use: The cutting edge seems blunt and chipped, but this may be due to later build-up and loss of corrosion product.

Reduction: The edge of the object appears bent and distorted, and there are some possible hammer marks associated with the break.

19/61 (Acc. No. 1961: 10-6: 33)

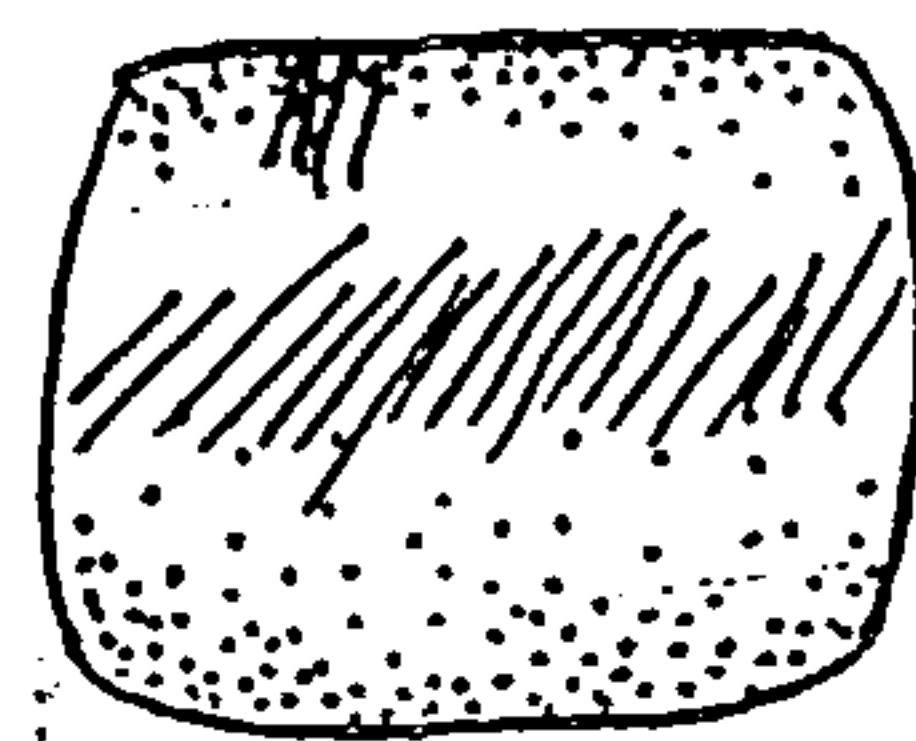
Description: Socketed hammer, with a single collar moulding around the mouth.

Dimensions: Length: 74mm. Weight: 225.5g.

Patina: Rough olive. Details obscured, with some sooty black deposits in places.

Manufacture: The casting seams have been removed around the mouth, but traces remain over the collar. There are grinding marks on the striking platform, especially in the area where the casting seam would once have been (fig.6). Slight depressions on one face are likely to have resulted from fine hammering associated with manufacture.

Fig. 6



Use: The survival of grinding marks on the striking platform and the generally fine condition of the piece suggests that the object was never used.

Reduction: The object is complete with no evidence relating to this process.

19/62 (Acc. No. 1961: 10-6: 62)

Description: Razor handle, consisting of two adjoining rings, which abutt a horizontal bar that would once have marked the point of transition into the main body of the razor.

Dimensions: Length (maximum): 52mm. Weight: 12.0g.

Patina: Dense dark olive with a dusty black deposit covering it in places.

Manufacture: The fragment appears well-finished, with no evidence of any casting seams remaining, but no other details can be seen on account of the corrosion buildup.

Use: There is no visible evidence of wear or use-related breakage.

Reduction: There is no evidence which relates to this process.

19/63 (Acc. No. 1961: 10-6: 45 (?46))

Description: Bronze bead.

Dimensions: Length: 10mm. Weight: 2.1g.

Patina: Dense olive.

Manufacture: The piece appears to have been well-finished, with no traces of any casting seams surviving.

Use: No signs of wear are apparent.

Reduction: The object is complete, with no evidence relating to this process.

19/64 (Acc. No. 1961: 10-6: 37)

Description: Hollow-cast bronze ring.

Dimensions: Diameter: 30mm. Weight: 8.8g.

Patina: Rough green.

Manufacture: A slight gap runs round the interior of the ring, and there are traces of a clay core still visible through this. In addition, the bronze has broken at one point, revealing the clay interior more clearly. There are indications of hammering and horizontal striations visible in places, and no traces of any casting seams survive. The piece could conceivably have been formed by shaping a thin sheet of bronze around a former, rather than by casting.

Use: There are no clear indications of use-related damage or wear.

Reduction: There is no evidence relating to this process.

19/65 (Acc. No. 1961: 10-6: 38)

Description: Solid-cast bronze ring, with a lozenge-shaped section.

Dimensions: Diameter: 31mm. Weight: 7.0g.

Patina: Much of the piece is bronze in colour with little corrosion buildup.

Manufacture: Evidence of fine hammering is apparent over the surface. On the exterior of the ring, the casting seam has been completely removed, though traces remain around the interior.

Use: No evidence can be directly linked with this stage of the object's life-cycle, though it is possible that one side of the interior appears smoother as a result of uneven wear.

Reduction: The object is complete and there is no evidence relating to this process.

19/66 (Acc. No. 1961: 10-6: 39)

Description: Solid-cast bronze ring, with flattened circular section.

Dimensions: Diameter: 34x39mm. Weight: 4.3g.

Patina: Rough grey-green.

Manufacture: The dimpled surface indicates that the object has been subject to fine hammering. No grinding marks are visible, but this may be due corrosion buildup. No traces of any casting seams survive.

Use: The object is of uneven thickness, which suggests excessive and differential wear.

Reduction: The piece appears distorted, both in its overall shape (it is now roughly elliptical in shape, as opposed to circular) and also in its profile. This could be use-related damage, though it could alternatively result from later damage. The hammering noted above may have caused this damage, but it seems rather too fine and too carefully executed to be linked with destruction.

19/67 (Acc. No. 1961: 10-6: 48)

Description: Circular sheet-bronze roundel, with tab-like attachments at either end, decorated with a central boss and 4 concentric embossed circles. The piece is likely to represent a decorative fitting from a cauldron or bucket.

Dimensions: Diameter: 19mm. Weight: 0.3g.

Patina: Pale grey-green.

Manufacture: The tabs appear to have been hammered.

Use: The piece is very worn and is battered in appearance, but whether this is use-related or not is unclear.

Reduction: The central boss is distorted, with a slightly squashed appearance, and its poor condition may result from the reduction process, e.g. the removal from its host object.

19/68 (Acc. No. 1961: 10-6: 49)

Description: Circular sheet-bronze roundel, with tab-like attachments at either side. It is decorated with a central boss surrounded by 4 concentric embossed rings. The piece is probably a decorative fitting from a cauldron or bucket.

Dimensions: Diameter: 17mm. Weight: 0.3g.

Patina: Rough grey-green.

Manufacture: There are traces of fine hammering on the tabs.

Use: There is no evidence relating to this process.

Reduction: There is no evidence relating to this process.

19/69 (Acc. No. 1961: 10-6: 50)

Description: Circular sheet-bronze roundel, with tab-like attachments at either side. It is decorated with a central depression, surrounded by 5 embossed concentric rings. The piece was probably a decorative fitting once associated with a cauldron or bucket.

Dimensions: Diameter: 15mm. Weight: 0.4g.

Patina: Rough grey-green.

Manufacture: There is no evidence relating to this process.

Use: The edges appear battered and torn, and the central depression has been broken or worn through, damage which may be use-related.

Reduction: There is no evidence relating to this process.

19/70 (Acc. No. 1961: 10-6: 51)

Description: Circular sheet-bronze roundel, with one tab-like attachment remaining at one side. It is decorated with a central boss, surrounded by 5 embossed concentric rings. The piece was probably a decorative fitting from a cauldron or bucket.

Dimensions: Diameter: 19mm. Weight: 0.2g.

Patina: Rough pale grey-green.

Manufacture: The surviving tab shows evidence of hammering.

Use: The edges are torn, and one tab is now missing, perhaps as a result of breakage through use.

Reduction: The missing tab may have been torn during removal from the host object, but this cannot be established with any certainty.

19/71 (Acc. No. 1961: 10-6: 52)

Description: Circular sheet-bronze roundel, with one remaining tab at the side. It is decorated with a central boss, surrounded by 3 concentric embossed rings. The piece was probably a decorative fitting from a cauldron or bucket.

Dimensions: Diameter: 15mm. Weight: 0.2g.

Patina: Rough olive, some bronze showing.

Manufacture: The tab has been subject to fine hammering.

Use: The edges are torn, and one tab is missing. This damage may be use-related.

Reduction: One of the embossed rings appears distorted, the central boss seems crushed, and one of the torn edges has been pushed downwards. This distortion probably results from hammering, perhaps associated with this fragment's removal from its host object.

19/72 (Acc. No. 1961: 10-6: 53)

Description: Circular sheet-bronze roundel, decorated with a central boss, originally surrounded by 4 concentric embossed rings. The piece was possibly a decorative fitting from a cauldron or bucket.

Dimensions: Diameter: 17mm. Weight: 0.2g.

Patina: Olive, with some pale green patches.

Manufacture: There is no evidence surviving which relates to this process.

Use: The edges are torn and battered, and the tab-like attachments found on other similar examples in this hoard have now gone, perhaps following use-related damage.

Reduction: The piece is now much distorted. One torn edge has been folded over on itself, and the pattern, which is difficult to see in places, has been obliterated in others. This seems to have occurred as a result of deliberate hammering, and one possible hammer indent is visible.

19/73 (Acc. No. 1961: 10-6: 54)

Description: Fragment of sheet bronze, sub-circular in shape, with tab-like attachments at either side. The piece is smaller than the other bronze roundels described in 19/67-72, and is undecorated.

Dimensions: Diameter: 7mm. Weight: 0.1g.

Patina: Mottled olive/mid-green.

Manufacture: The surface shows extensive hammering, but this may post-date the manufacturing process.

Use: The edges are torn, and one tab is now partially missing. The surface is worn through in places, too. All of this damage may be use-related.

Reduction: The surface has an undulating appearance, and this is probably associated with hammering inflicted at this stage in the object's life-cycle.

19/74 (Acc. No. 1961: 10-6: 55)

Description: Fragment of sheet bronze, possibly a tab-like attachment from a decorative fitting.

Dimensions: Length (maximum): 19mm. Weight: 0.1g.

Patina: Olive-green.

Manufacture: The piece has been finely hammered and this may date from work carried out in manufacture.

Use: There is no evidence pertaining to this stage in the object's life-cycle.

Reduction: There is no evidence relating to this process.

19/75 (Acc. No. 1961: 10-6: 56)

Description: Fragment of decorated sheet bronze. There is one straight edge surviving, which meets a more curved and concave edge in a manner which suggests a thin tab or tang. Two ribs run along the length of the straight edge, and a row of repousse dot decoration runs along the concave edge. The function cannot be determined, though the thin nature of the metal and its decoration suggests that it was intended to be ornamental.

Dimensions: Length (maximum): 36mm. Weight: 0.2g.

Patina: Some bronze showing, with patches of rough pale green patina present.

Manufacture: Extensive fine hammering is visible over the extent of the surface, and this is probably linked with manufacture.

Use: The lower edge is folded and crumpled. This may indicate use-related damage.

Reduction: The piece has broken in antiquity, and there are some hammer marks in its centre which seem too invasive to be in keeping with the subtle hammer work visible elsewhere. Where the object narrows, it appears to have been bent over itself at the end. Finally, there is the crumpling of the edge mentioned above, where the corner of the broken

edge appears to have been pushed downwards, and it is possible that this damage was also inflicted deliberately.

19/76 (Acc. No. 1964: 10-6: 60)

Description: Fragment of sheet bronze, with two ribs running parallel to the surviving edge, and a single row of repousse dots running between the ribs and the edge. The decoration has similarities with that seen on 19/75 above, and the possibility that both fittings were once used to embellish the same object cannot be discounted.

Dimensions: Length: 23mm (maximum). Weight: 0.2g.

Patina: Mainly rough grey-green, with some clearer olive or bronze patches.

Manufacture: Fine hammering over the surface is visible, and this was probably part of the manufacturing process.

Use: The object appears battered, with its edges torn, though its tatty appearance has undoubtedly been exaggerated by later corrosion buildup. Only one edge survives in recognisable form.

Reduction: Some of the hammering is more roughly executed, causing distortion, and this damage is probably related to the destructive process.

19/77 (Acc. No. 1961: 10-6: 59)

Description: Small fragment of sheet bronze, with what appears to be part of a bronze roundel adhering to the surface.

Dimensions: Length (maximum): 12mm. Weight: 0.5g.

Patina: Rough grey-green.

Manufacture: The piece has been finely hammered across its extent, and there are horizontal grinding marks on one side.

Use: Impossible to determine, because no evidence survives and because the original function of the fragment cannot be identified.

Reduction: There are possible small tool marks at one of the broken edges.

19/78 (Acc. No. 1961: 57)

Description: Fragment of sheet bronze strip.

Dimensions: Length: 37mm (maximum). Weight: 2.0g.

Patina: Rough grey-green, some bronze showing.

Manufacture: The surface undulates slightly as a result of fine hammering, and this is probably linked with manufacture.

Use: The edges are slightly rough and notched, but it is difficult to establish when this damage might have been inflicted.

Reduction: The section and the profile are distorted, probably as a result of rough hammering that was inflicted at this stage in the object's life-cycle. The piece was stored folded over 19/78, and it seems likely that these are two fragments of the same piece which was broken in antiquity. However, the two broken edges do not appear to match exactly, which might suggest that a third intervening fragment once lay between them.

19/78 (Acc. No. 1961: 10-6: 58)

Description: Fragment of sheet bronze strip.

Dimensions: Length (maximum): 29mm. Width: 17mm. Weight: 1.3g.

Patina: Mainly rough, pale grey-green.

Manufacture: The piece shows evidence of fine hammering over its surface.

Use: The edges are notched and rough in places, but it is unclear whether this damage came about through use or whether it occurred at a later point in the object's life-cycle.

Reduction: The piece has been distorted as a result of hammering, and this is likely to be associated with this stage of the object's life-cycle. This fragment may be part of the same object as 19/78, though the two broken edges are not an exact match.

19/81 (Acc. No. 1961: 10-6: 66)

Description: Large piece of copper ingot.

Dimensions: Length: 89mm. Width: 50mm. Weight: 401.0g.

19/82 (Acc. No. 1940: 7-3: 55)

Description: Casting reservoir from unknown object.

Dimensions: Length: 53mm. Width: 40mm. Thickness: 17mm.

19/83 (Acc. No. 1961: 10-6: 85)

Description: Fragment of sheet bronze.

Dimensions: Length (maximum): 67mm. Weight: 6.7g.

Patina: The original bronze colour shows and the piece may have been chemically treated.

Manufacture: Much pitting is apparent in the metal. The surface is undulating in appearance, as a result of rough hammer working.

Use: There is no evidence relating to this process.

Reduction: The edges have been folded over, and rough hammer marks are visible in association with this damage.

19/83 (Acc. No. 1961: 10-6: 86)

Description: Fragment of sheet bronze, now in two pieces.

Dimensions: Length: 51mm. Width: 22mm. Weight: 2.5g.

Patina: The original bronze colour shows and the piece may have been chemically treated.

Manufacture: The surface is covered with hammer indents. Some may be linked with the manufacturing process.

Use: No evidence can be related to this process.

Reduction: The break occurred in antiquity. Some of the hammer indents noted above are more pronounced and these may be linked with this stage in the object's life-cycle.

19/84 (Acc. No. 1961: 10-6: 47)

Description: Fragment of bronze wire twisted roughly into a hook shape. One side only has a ribbed appearance, and the piece has not been formed from a group of finer wires. The fragment is roughly circular in section, thinning towards one end. It has been identified as a fish-hook (NBI), but its flimsy nature argues against this possibility.

Dimensions: Length (maximum): 52mm. Weight: 2.6g.

Patina: Very rough olive, with grey-green patches in places. Details obscured.

Manufacture: The decoration appears to have been an integral part of the casting.

Use: There is no evidence relating to this stage in the object's life-cycle.

Reduction: There is no evidence relating to this process.

19/85 (Acc. No. 1961: 10-6: 46)

Description: Fragment of bronze wire.

Dimensions: 9x11mm. Weight: 1g.

Patina: Olive-green, with rather polished appearance, with some rougher grey-green patches.

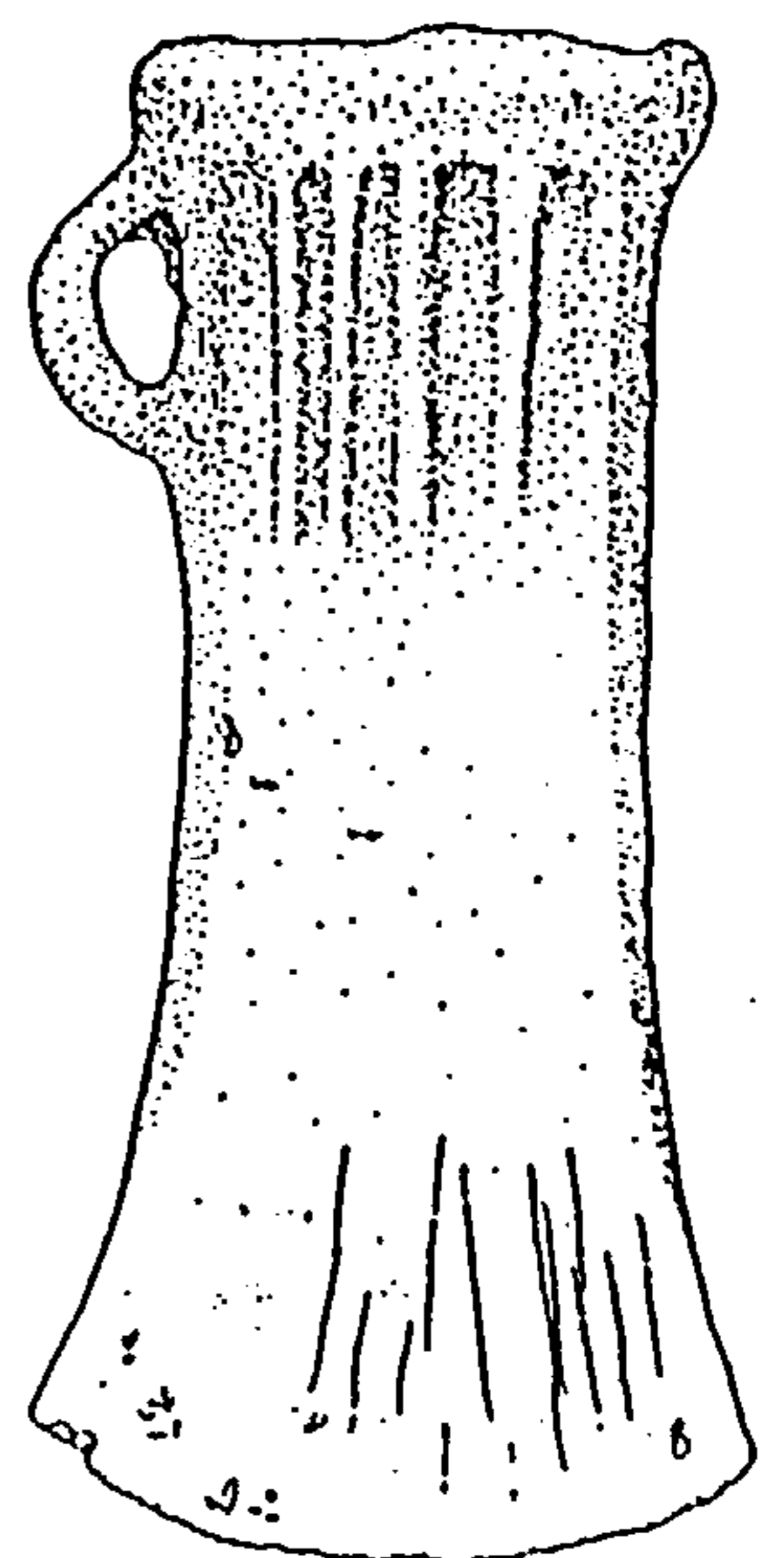
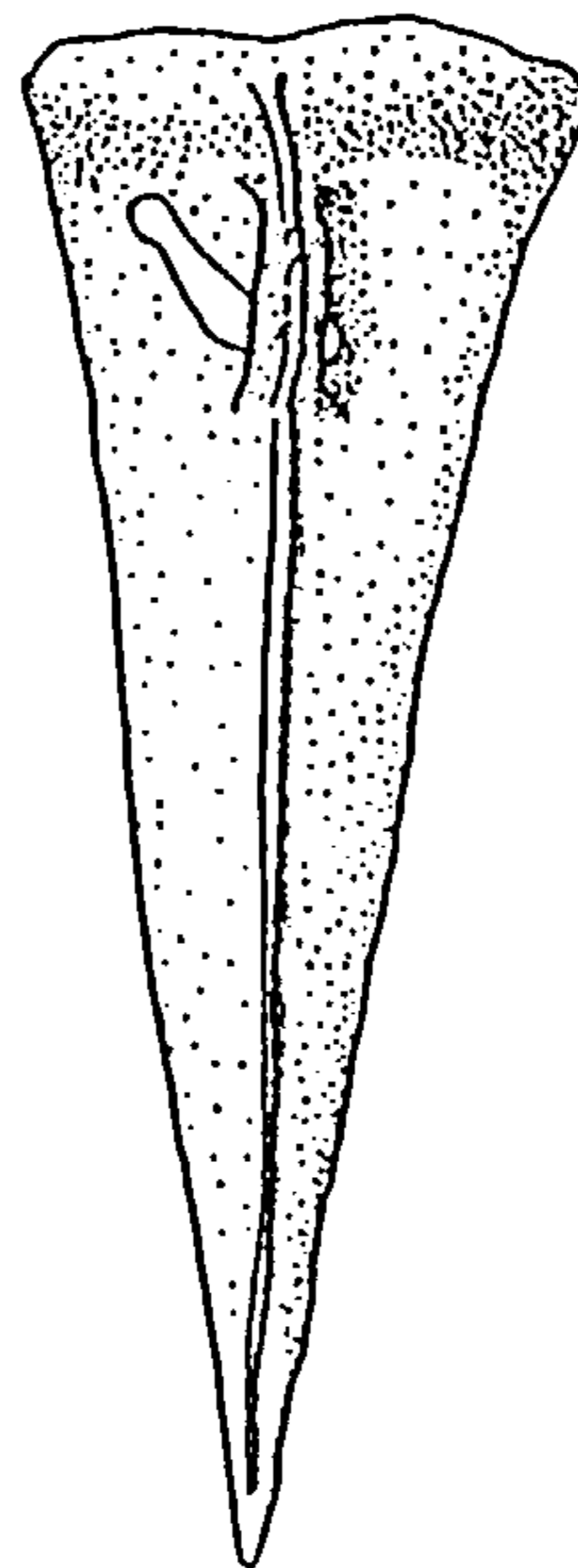
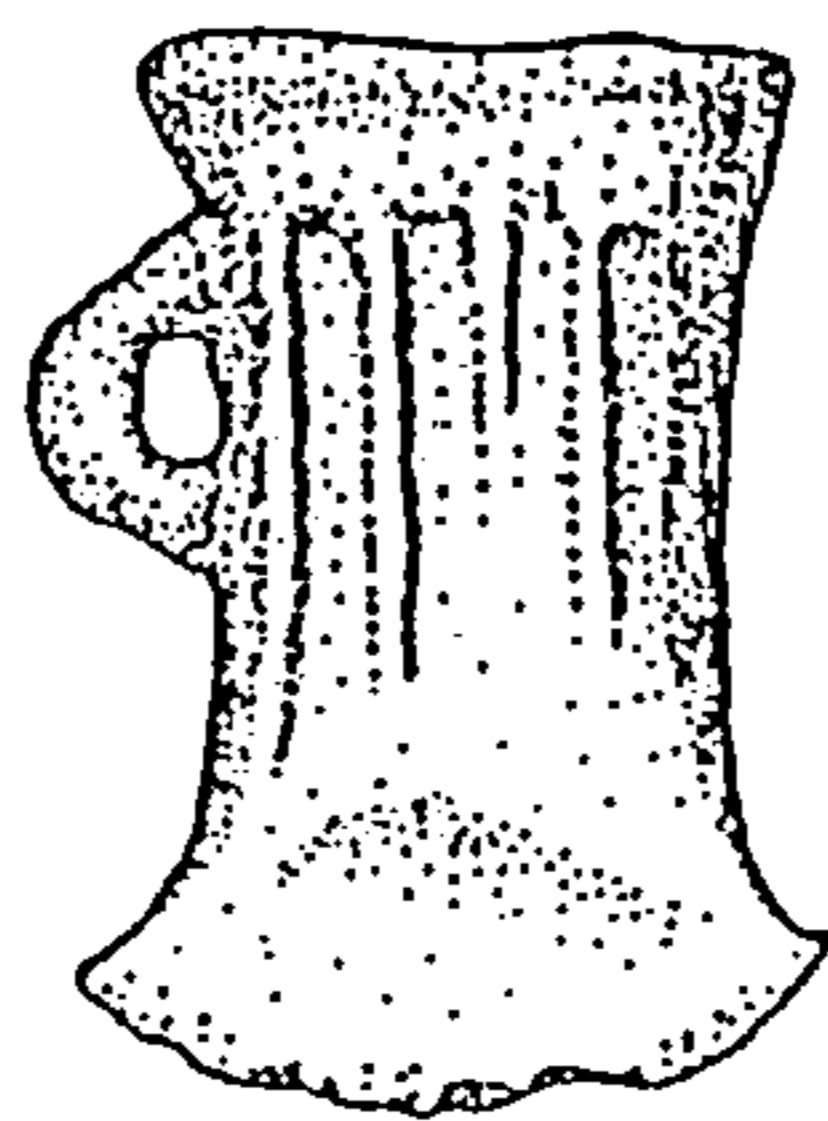
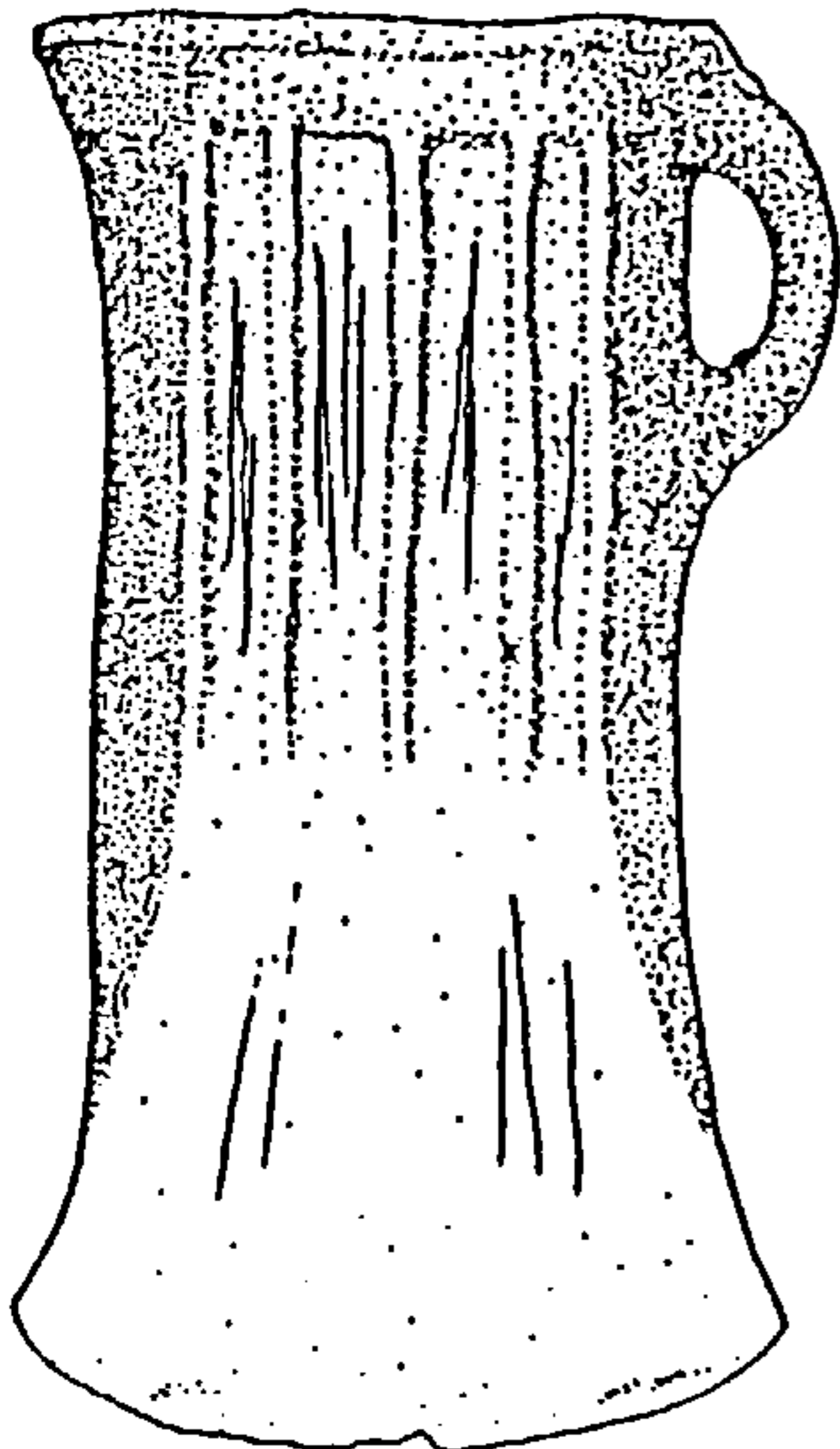
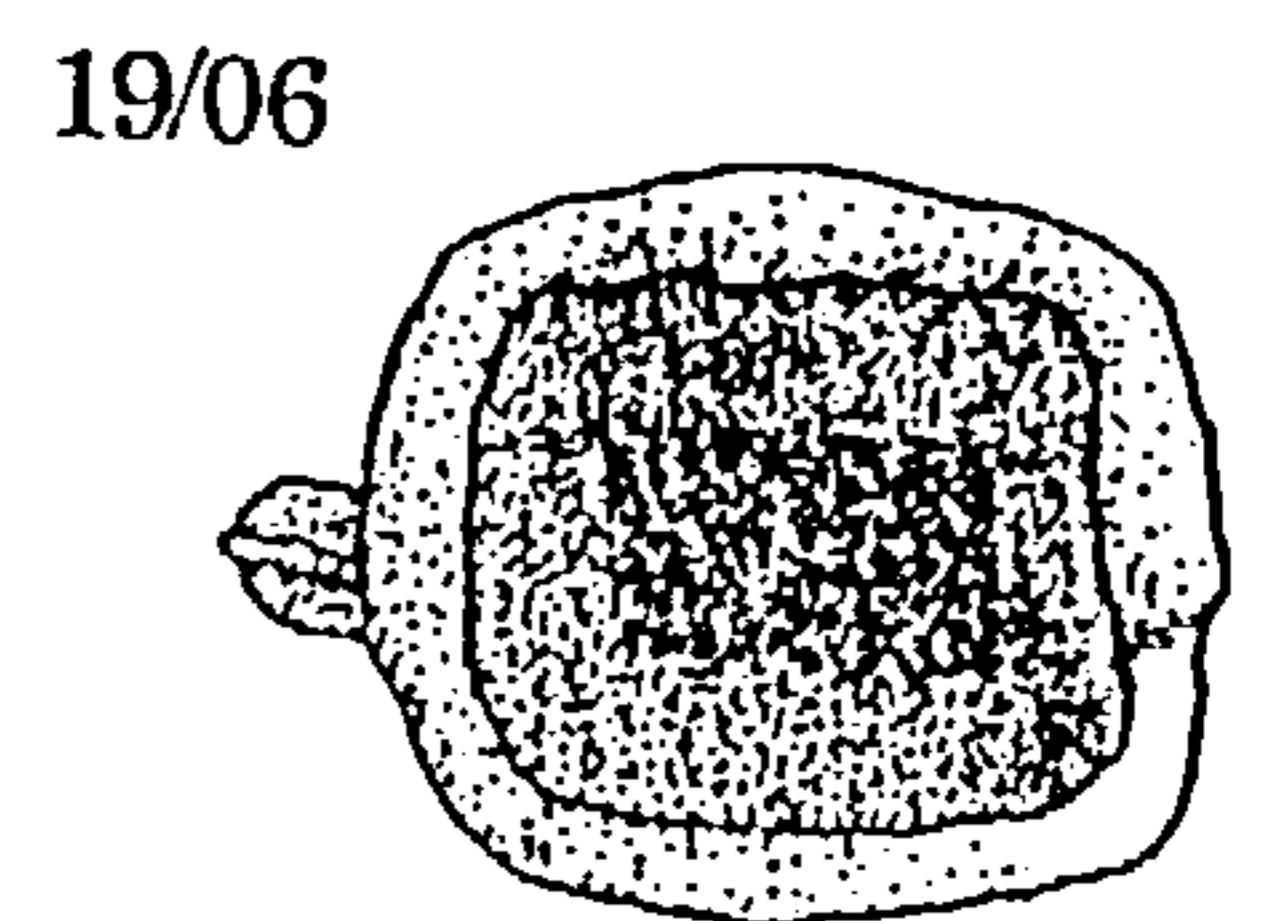
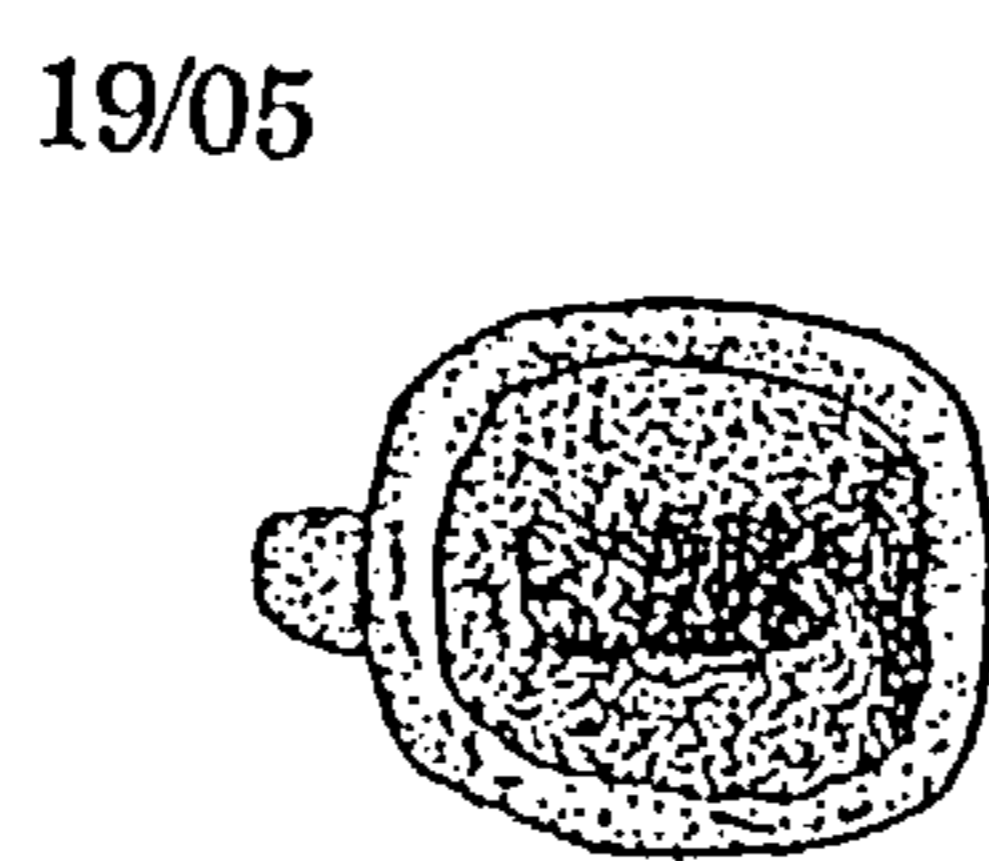
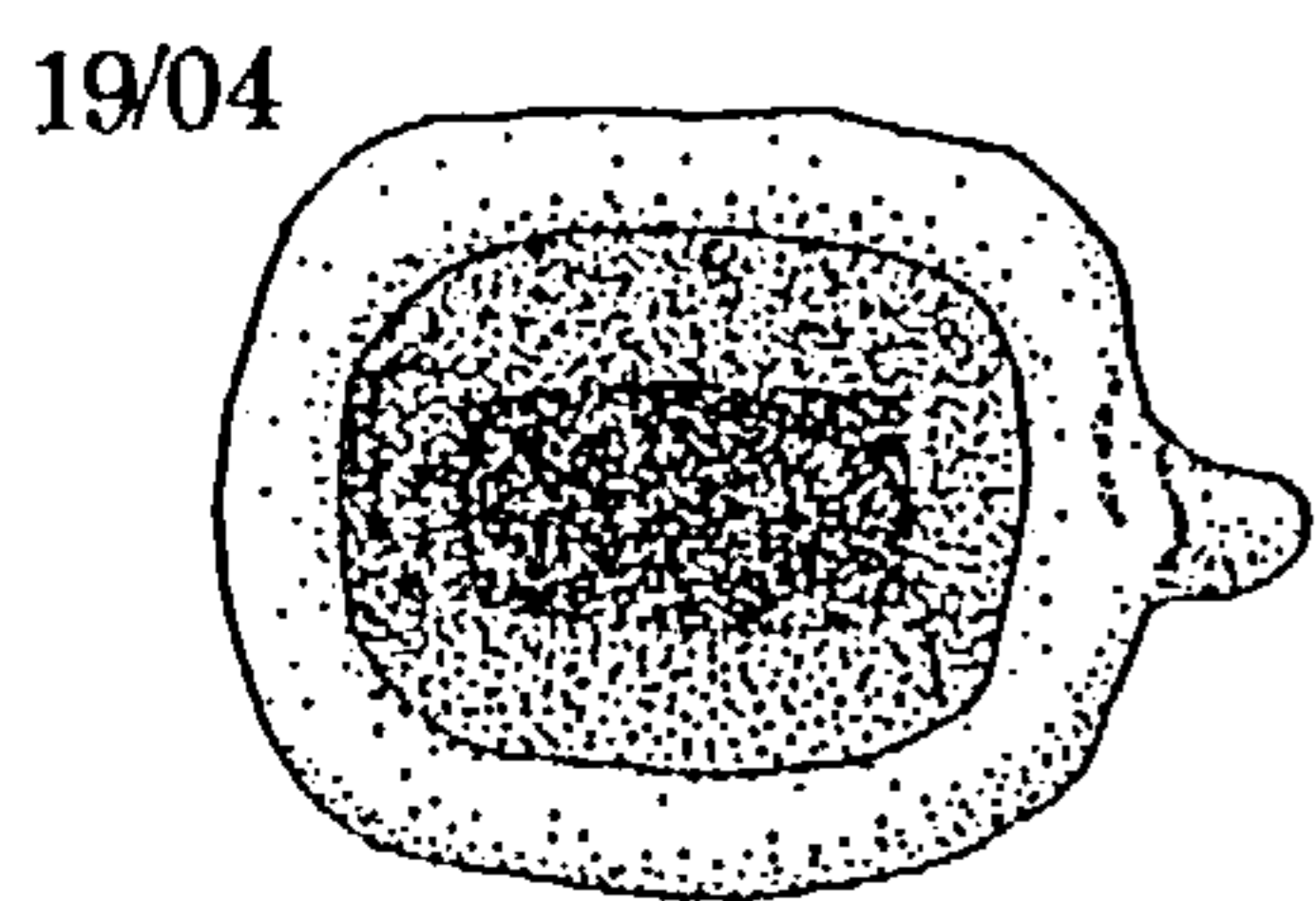
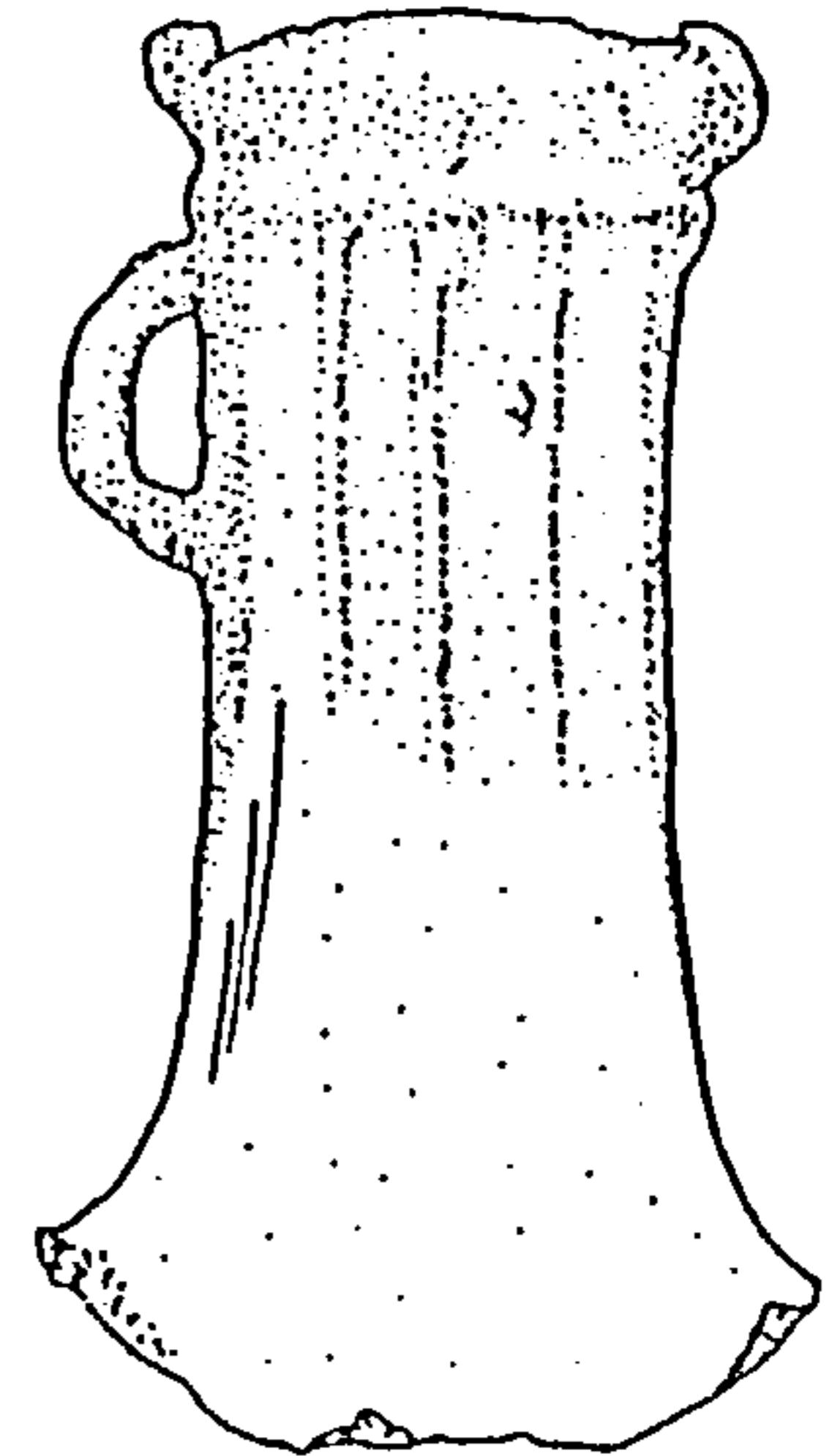
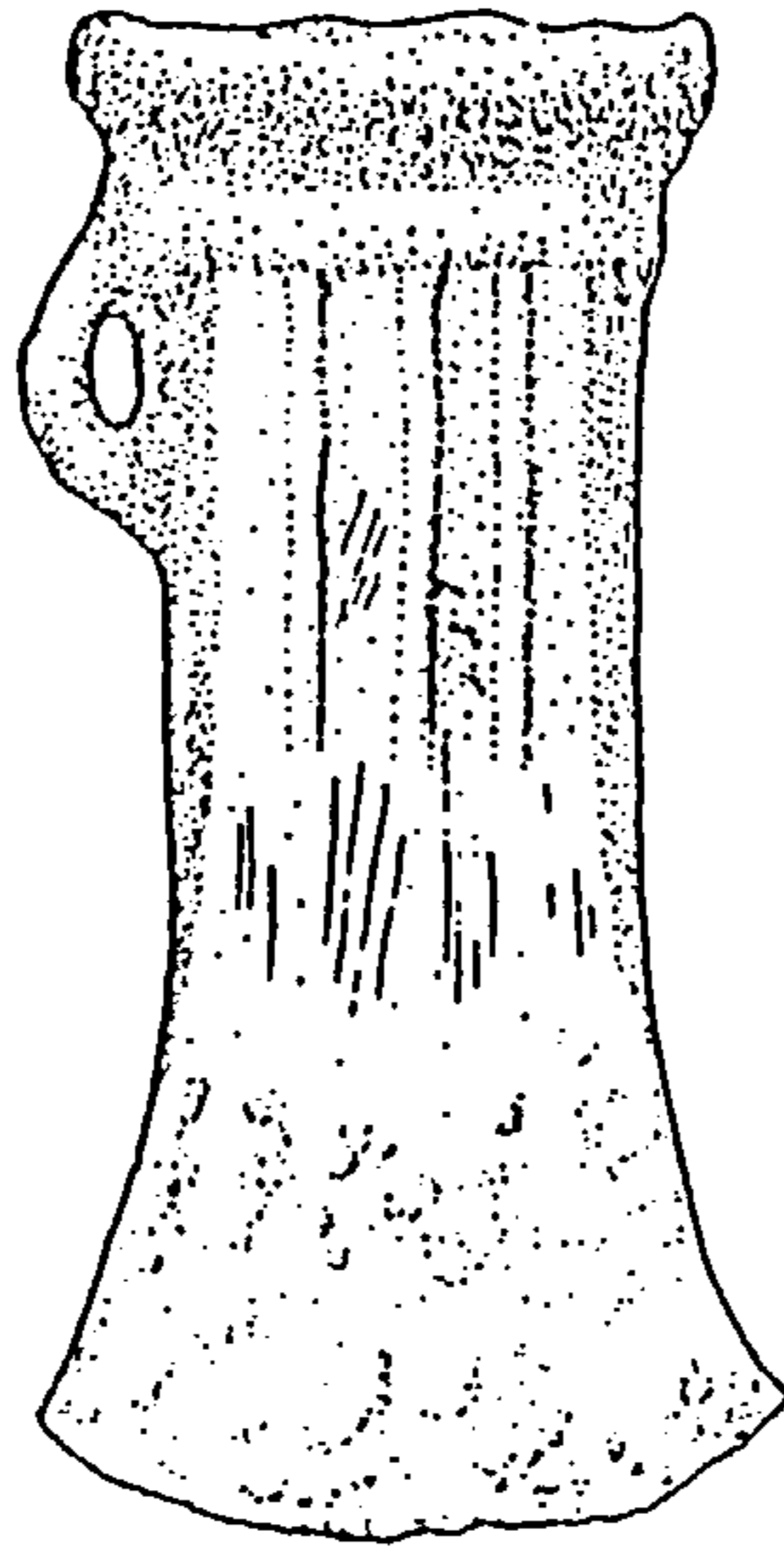
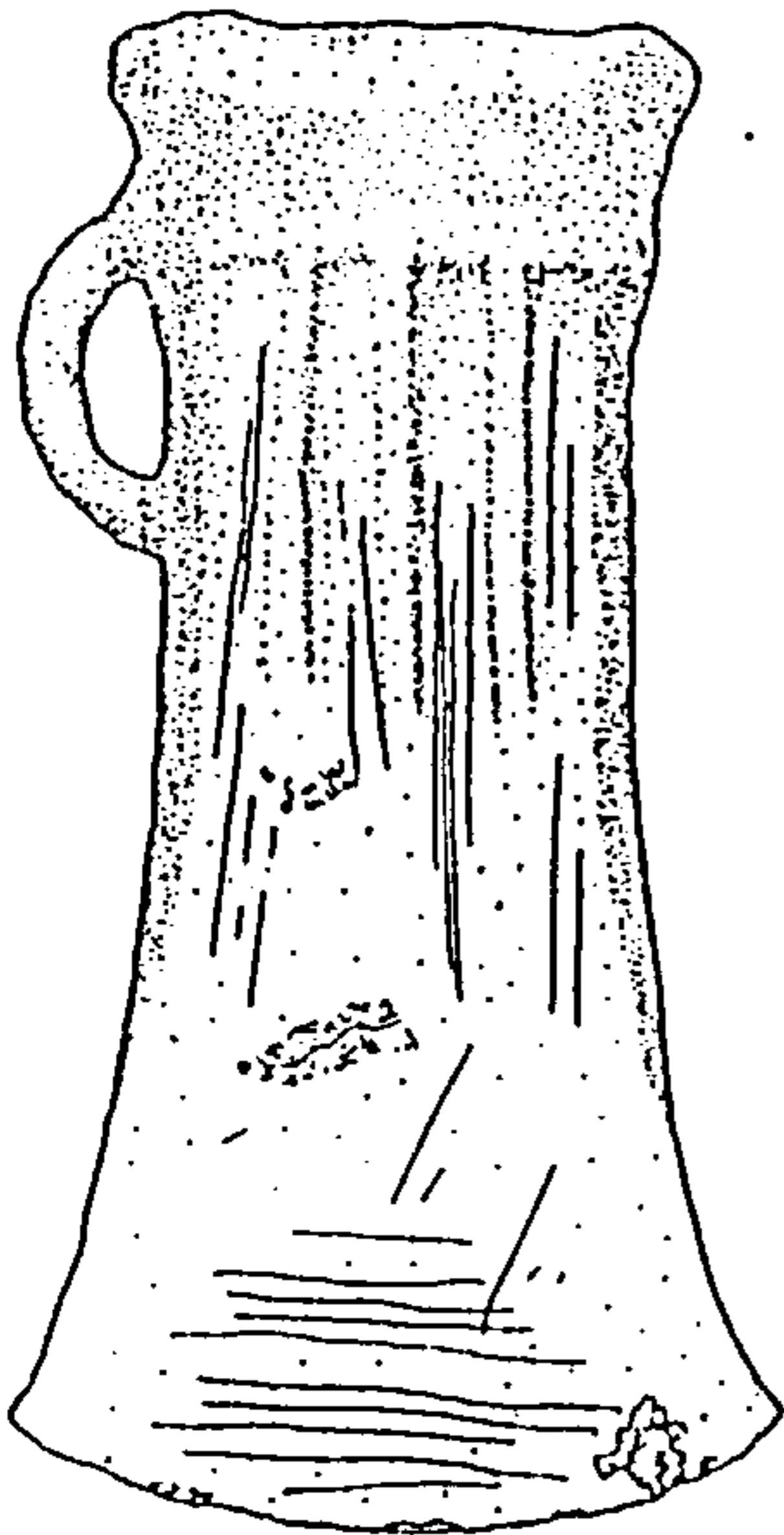
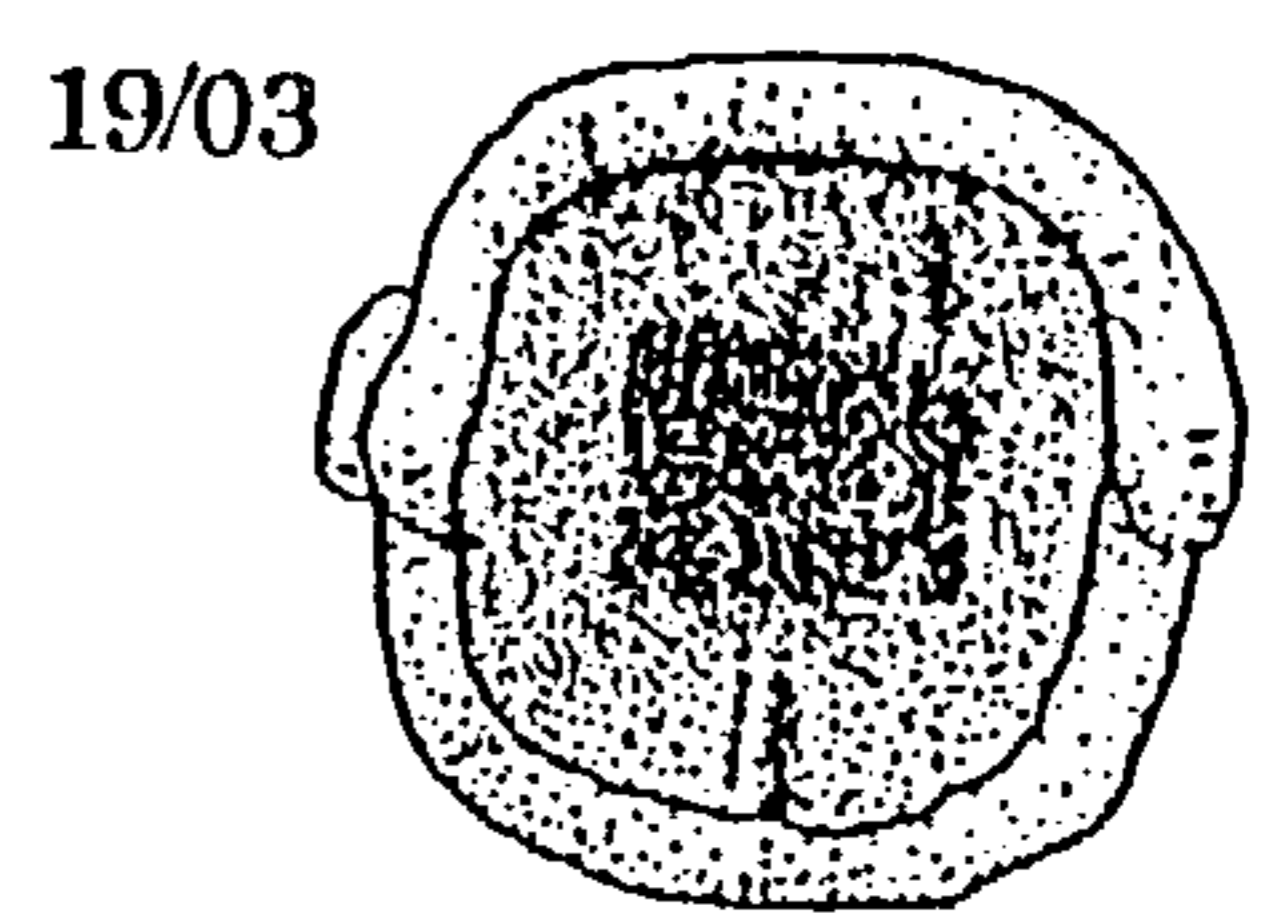
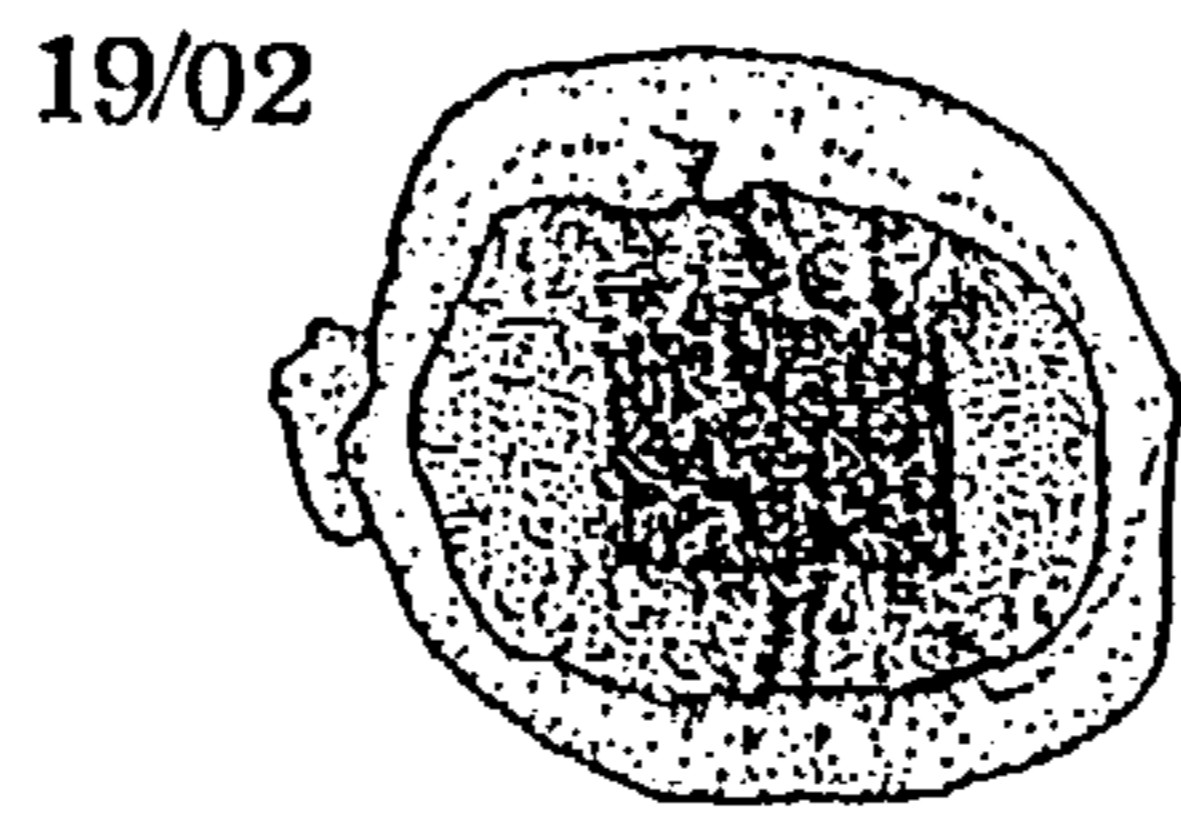
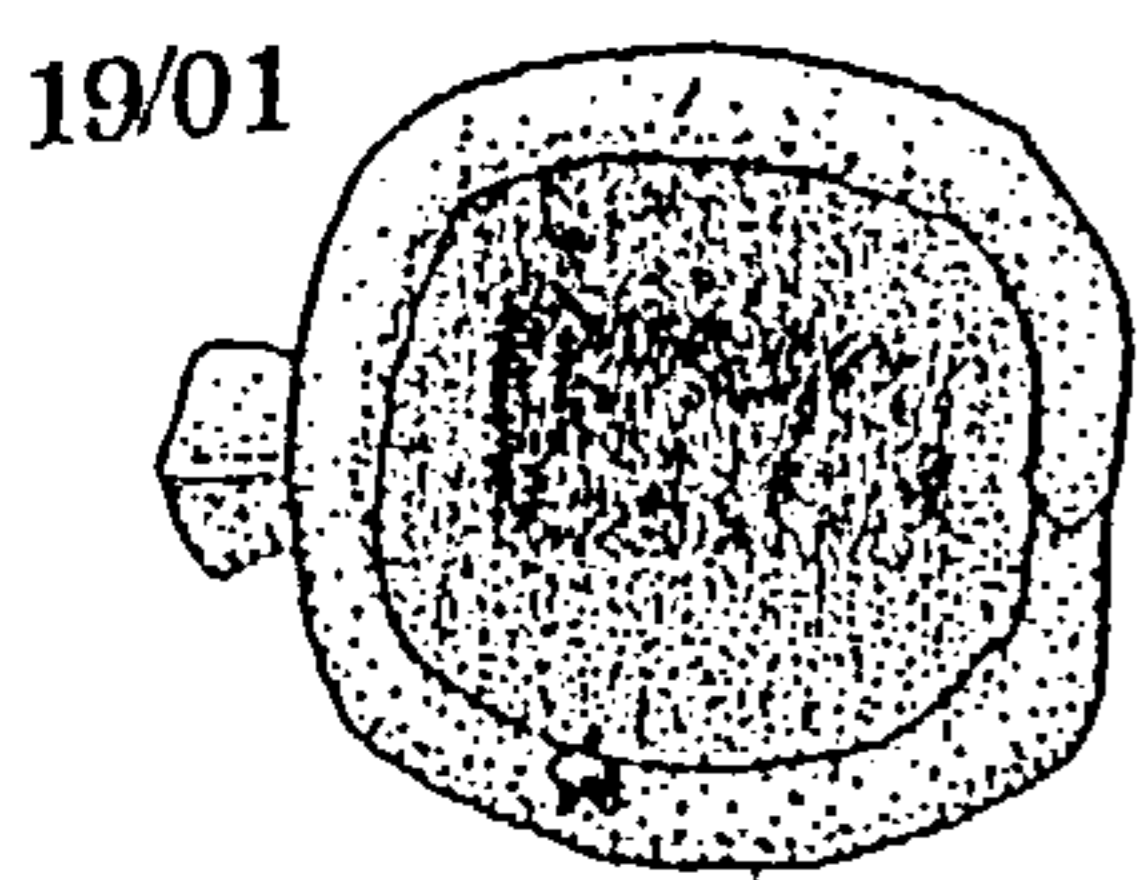
Manufacture: There is no evidence relating to this process.

Use: There is no evidence relating to this stage in the object's life-cycle.

Reduction: Small tool marks upon the surface might have been inflicted during the process of bending the wire into the desired shape. The hammer indents visible near the break may have been inflicted during this same process, but it is possible that they occurred during the closing stages of the object's life-cycle, i.e. during fragmentation.

19/86 (Acc. No. 1961: 10-6: 87)

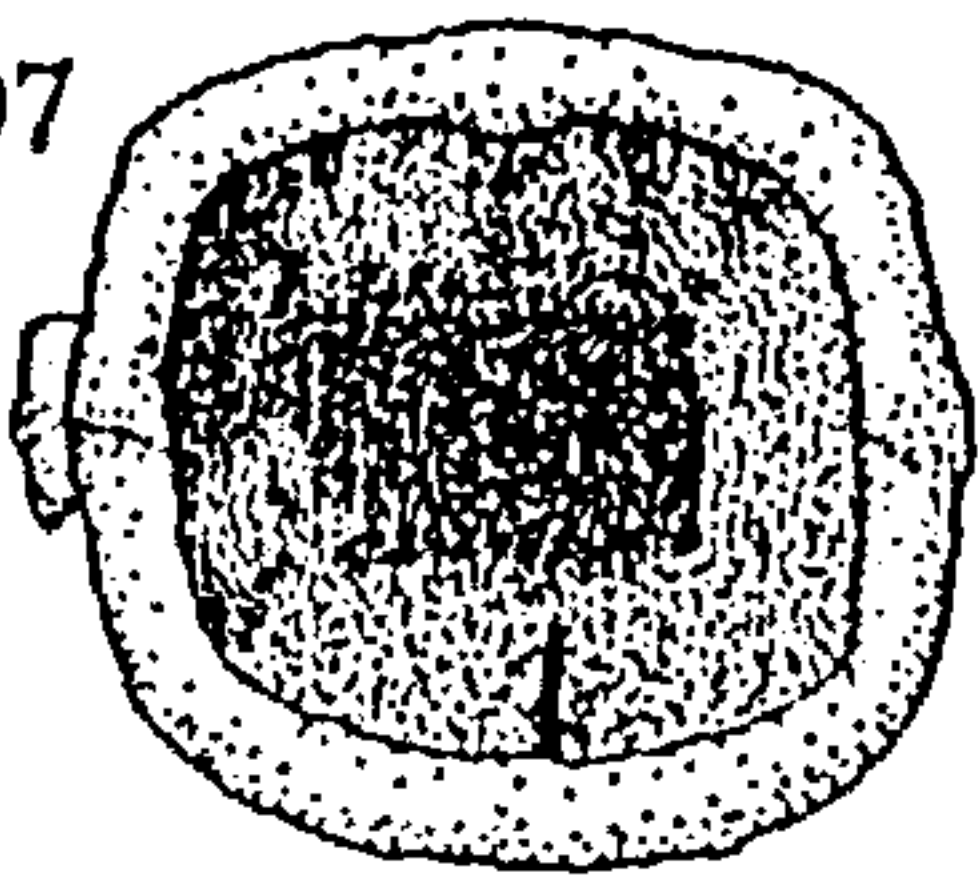
Description: This fragment is catalogued as a piece of 'bronze cake', but it appears quite different to any of the ingot metal fragments encountered, its surface appearing unusually crazed and cracked. XRF recently carried out upon the piece by British Museum staff revealed it to be a lump of marcasite.



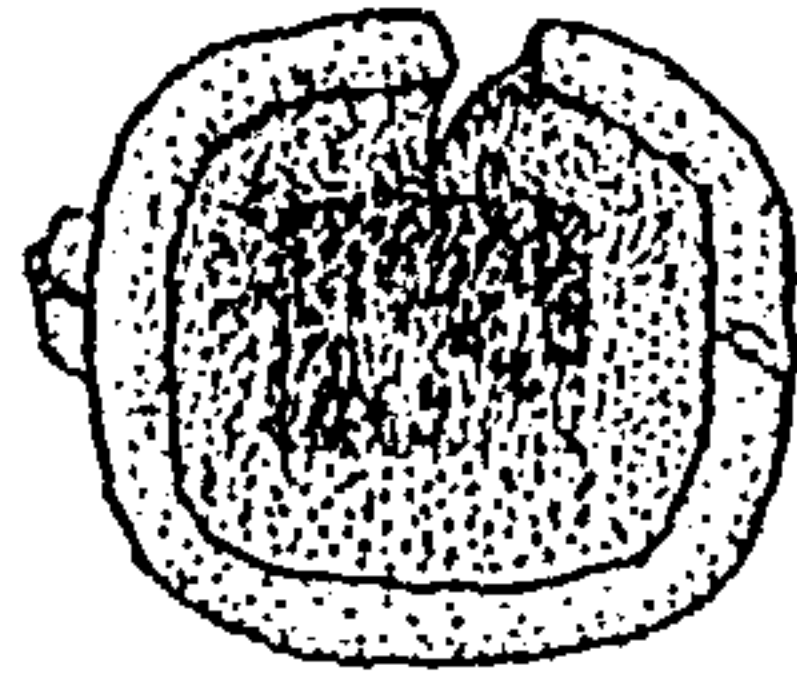
0 2cm

Fig. 40 The Minnis Bay Hoard (Ref. No. 19): Complete Socketed Axes

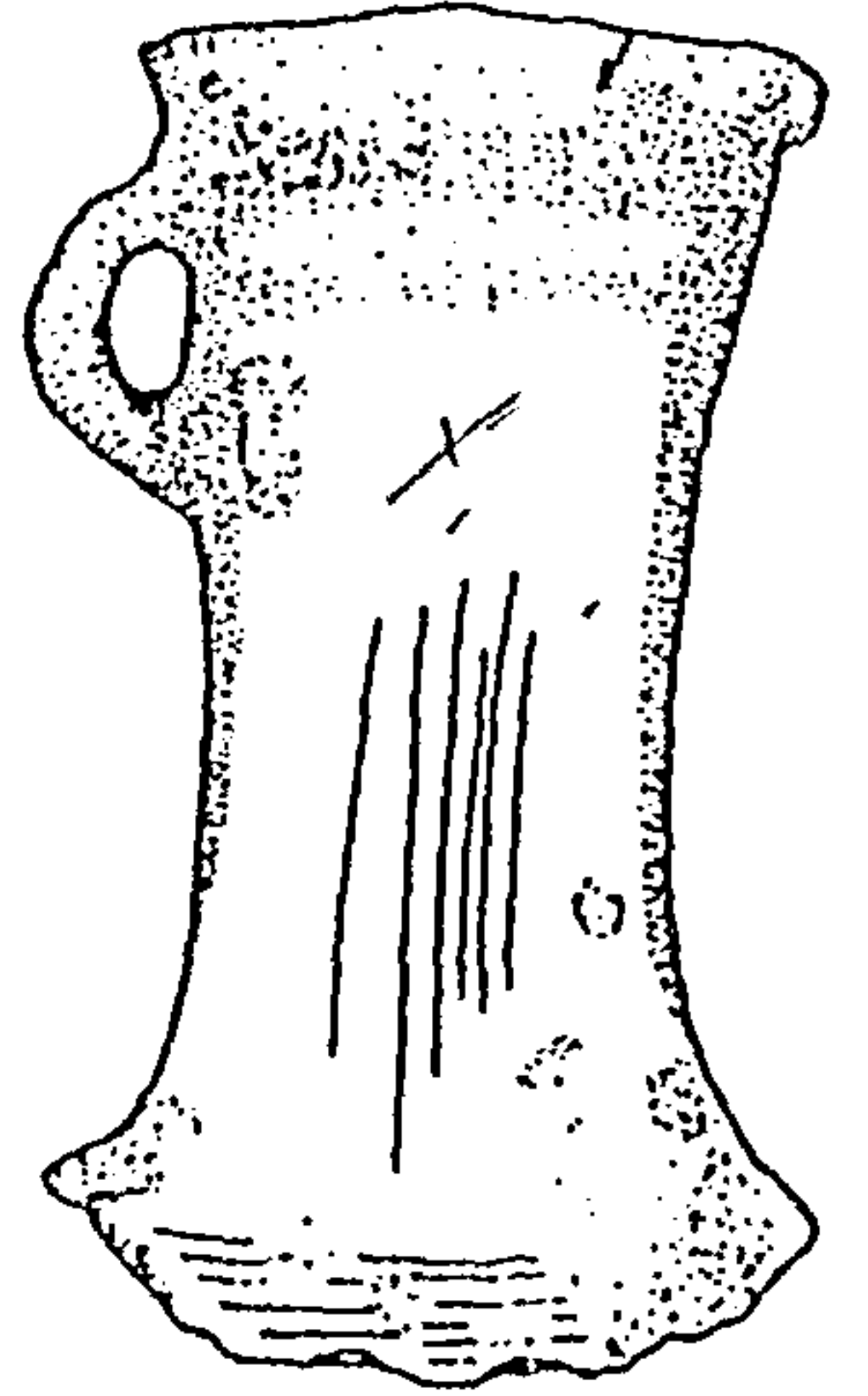
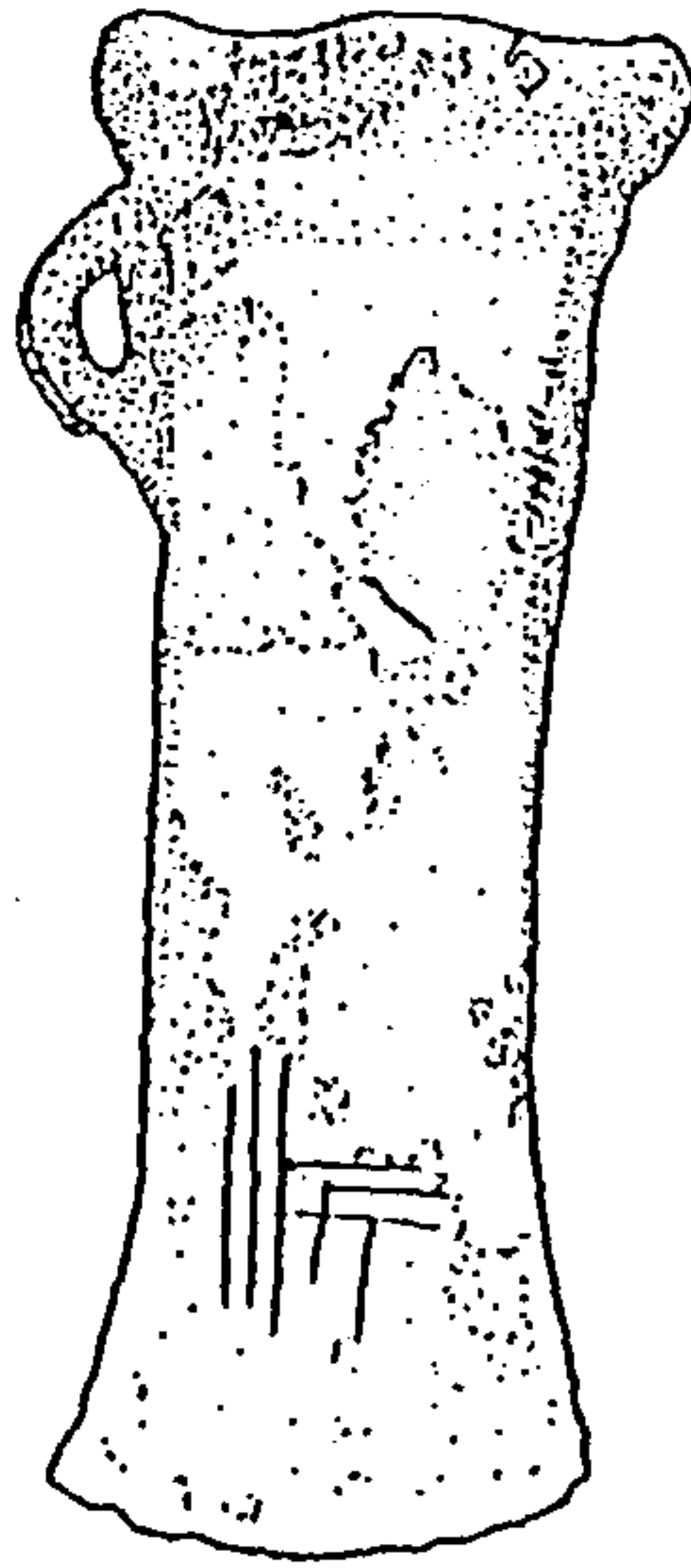
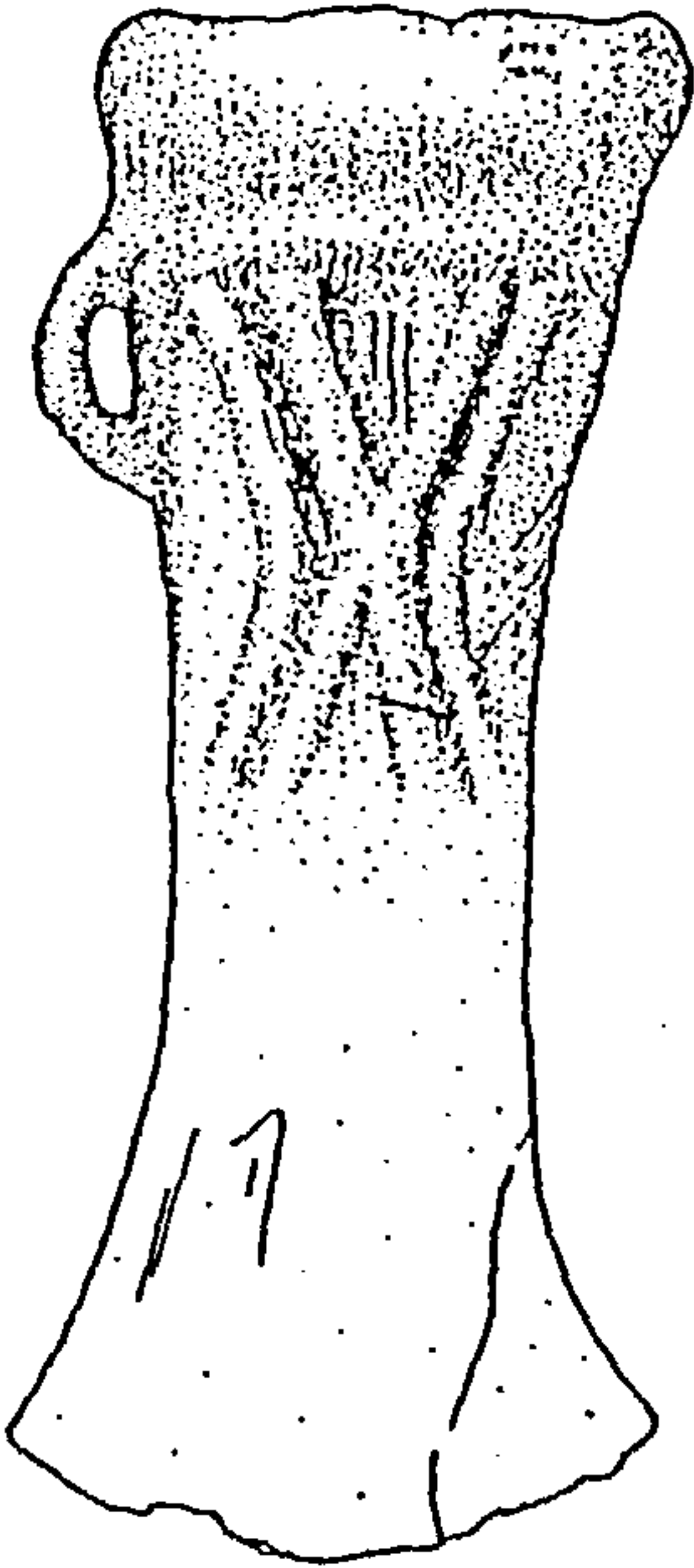
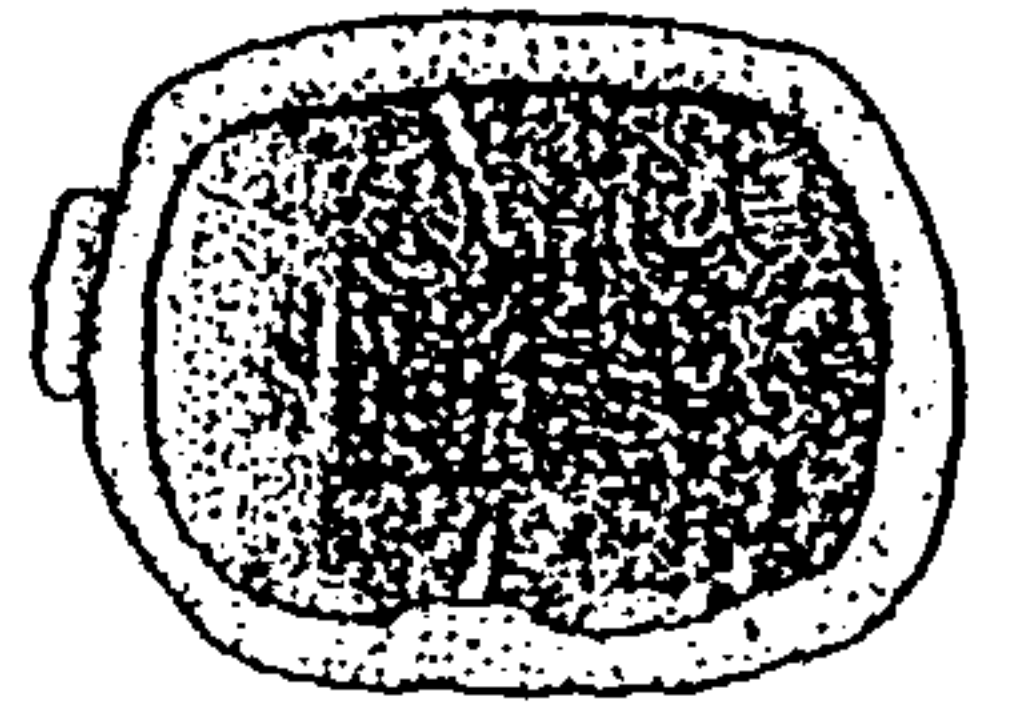
19/07



19/08

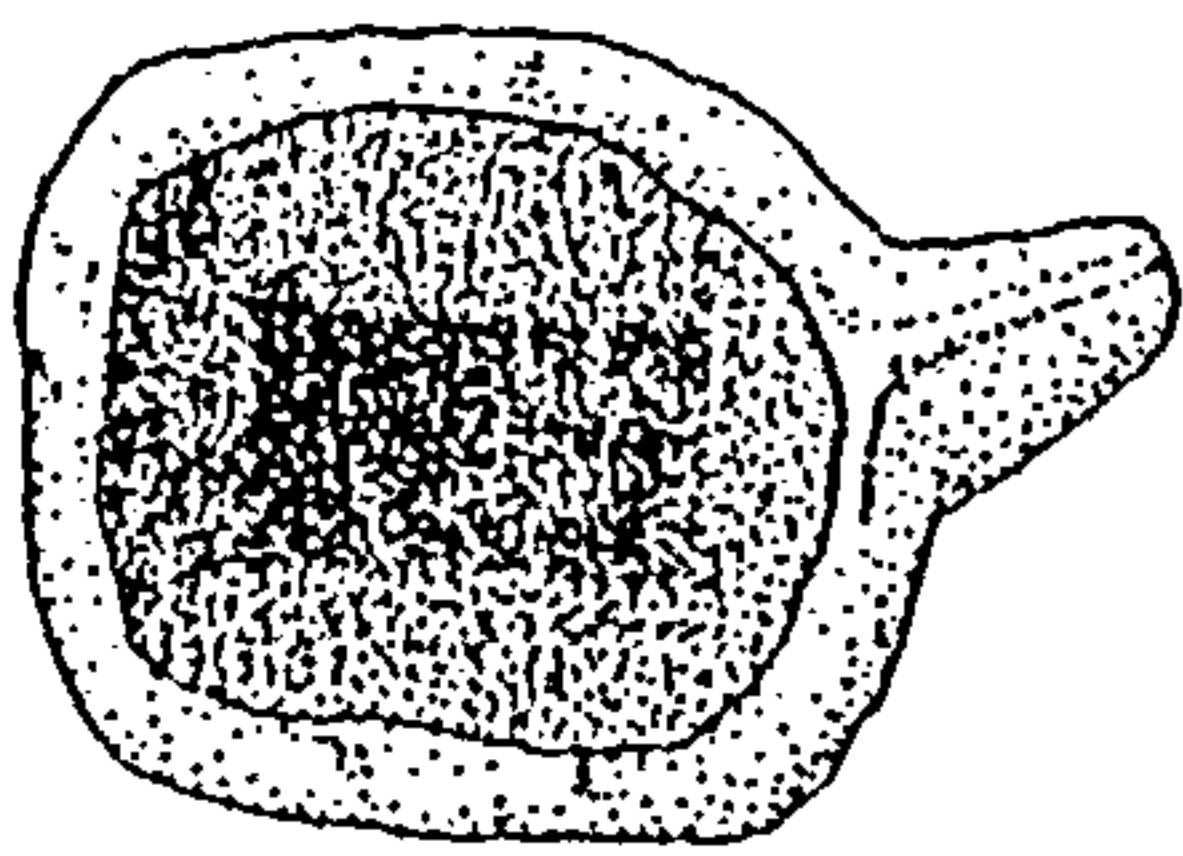


19/09



0 2cm

19/10



19/11

19/12

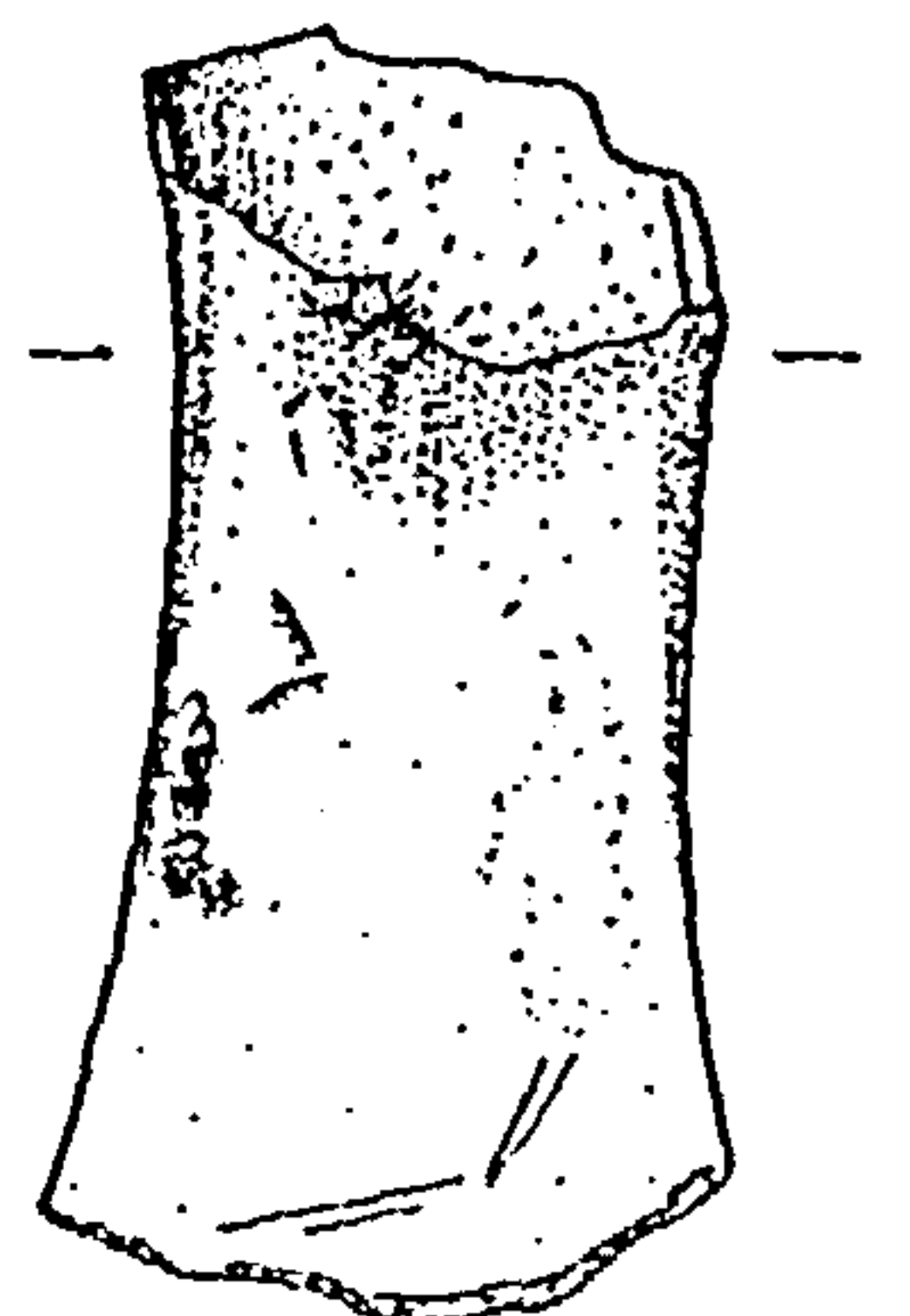
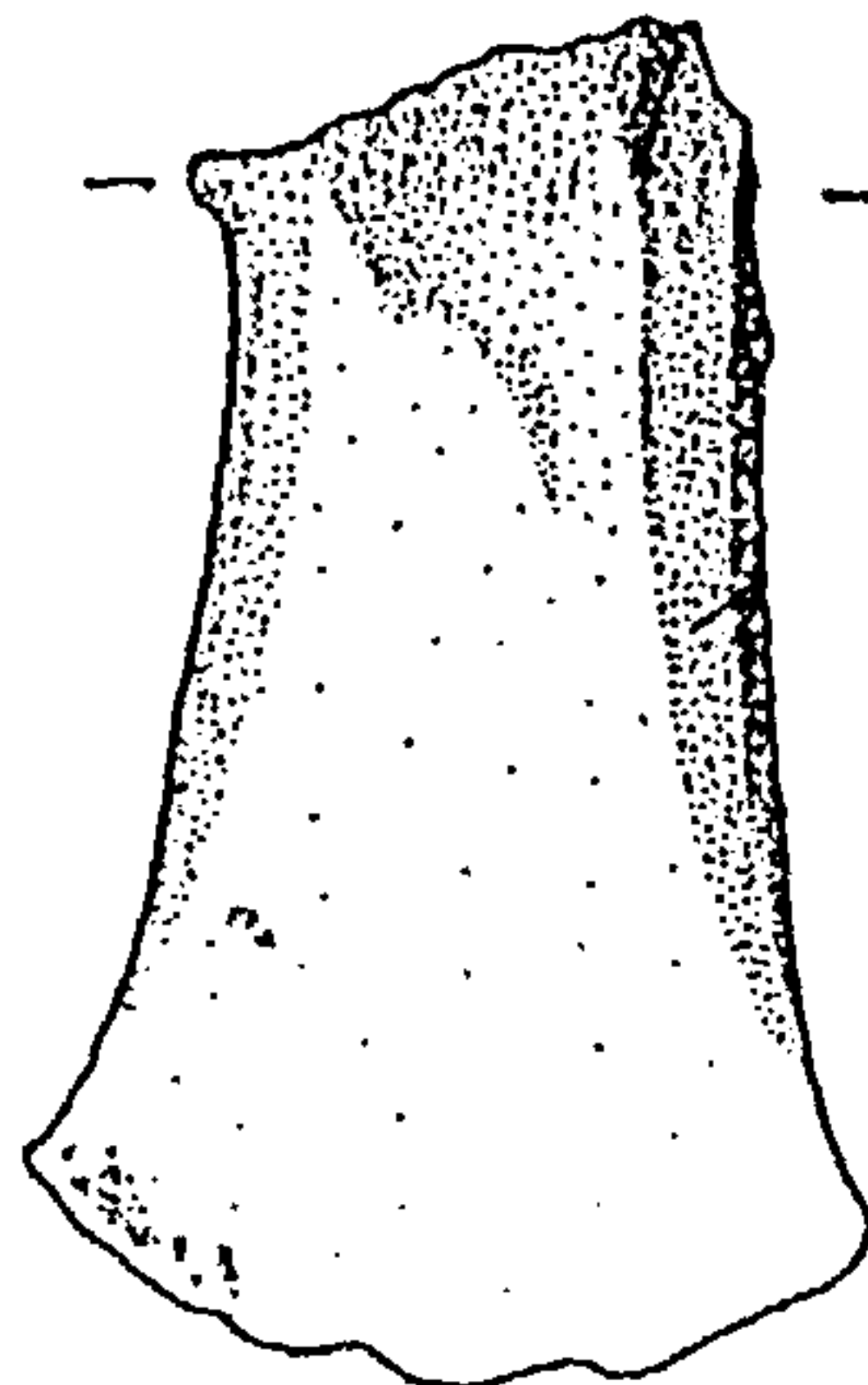
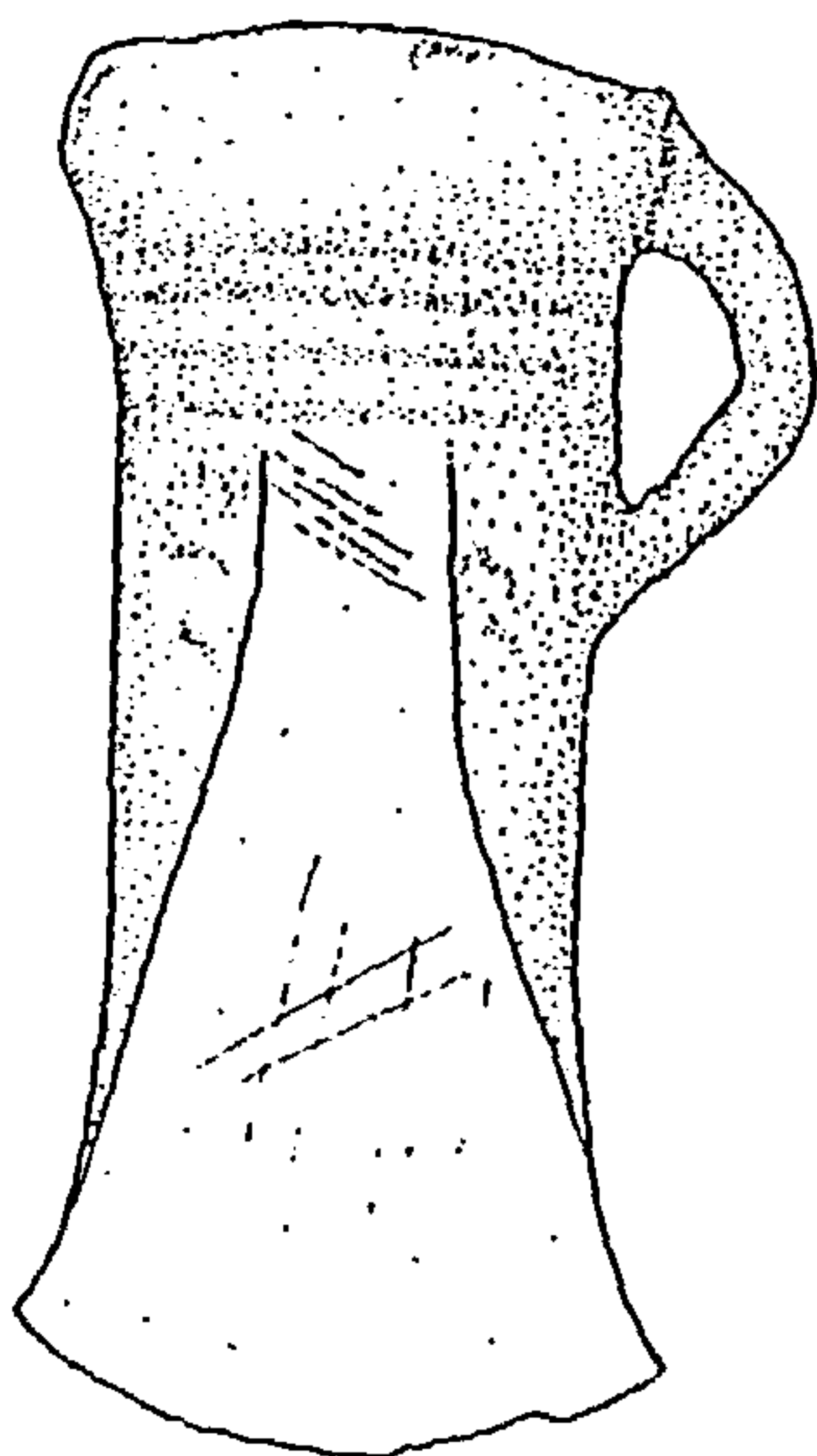
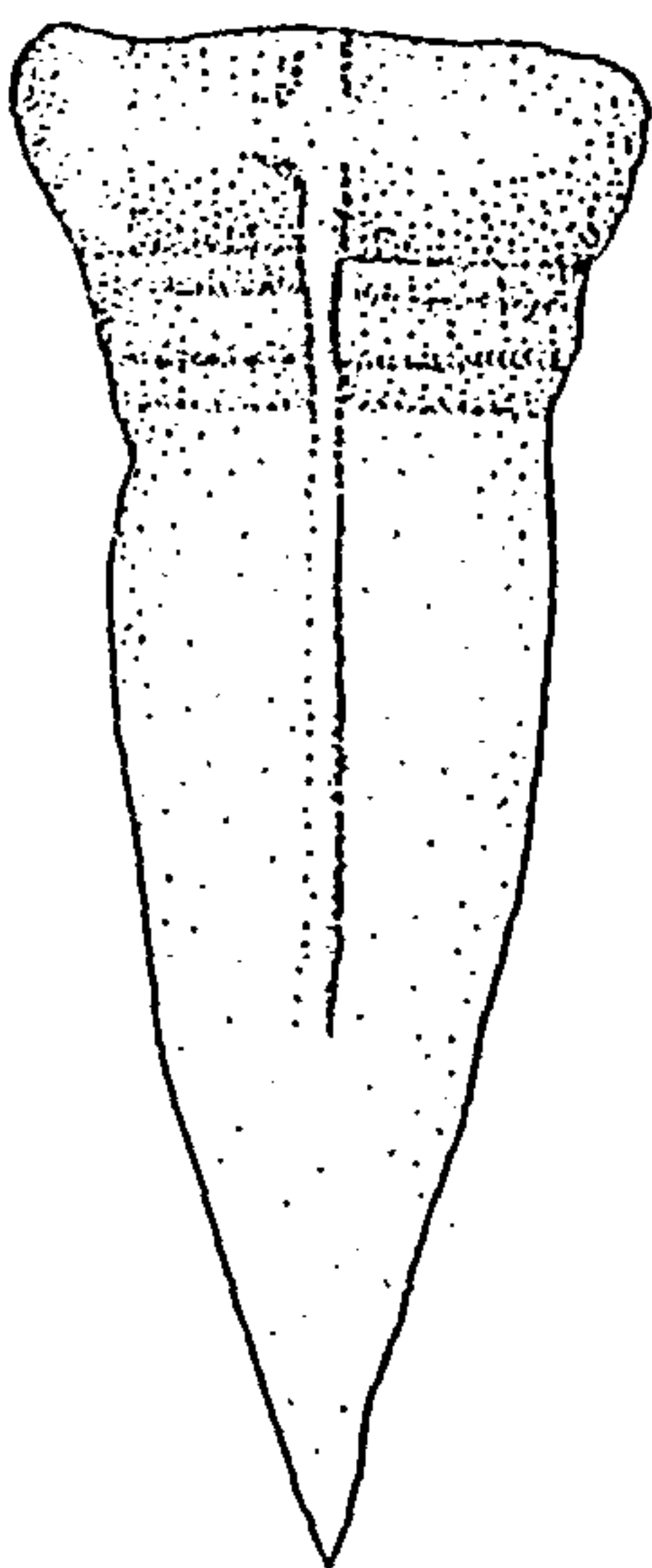
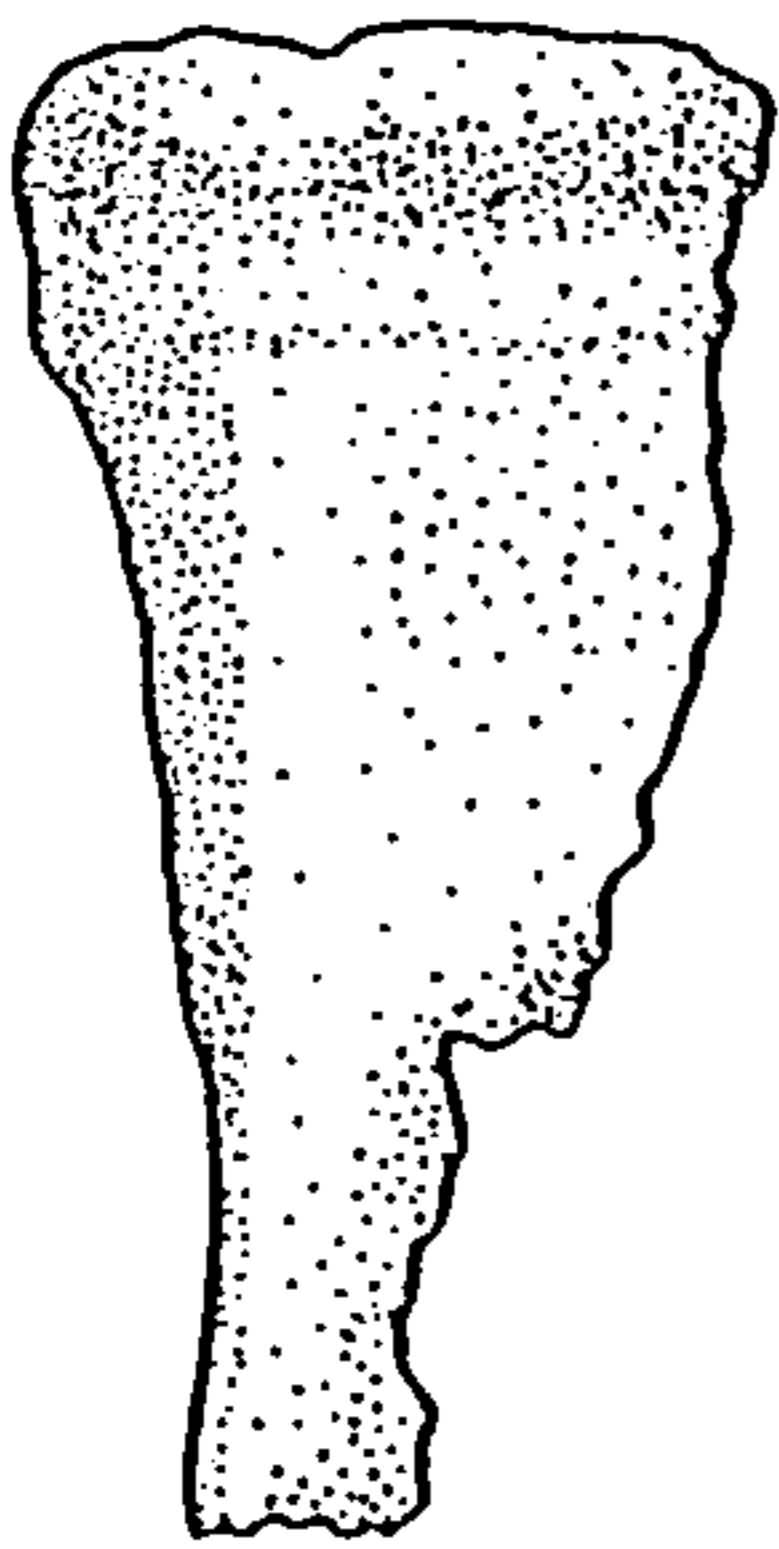
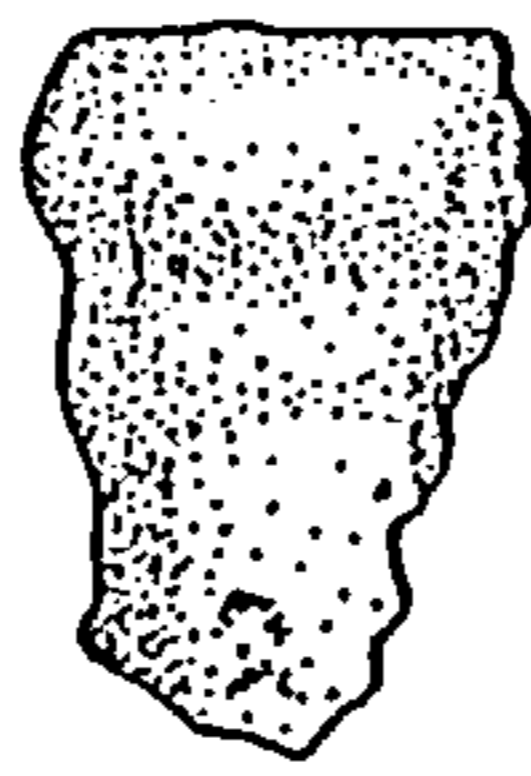


Fig. 41: The Minnis Bay Hoard (Ref. No. 19): Socketed Axes

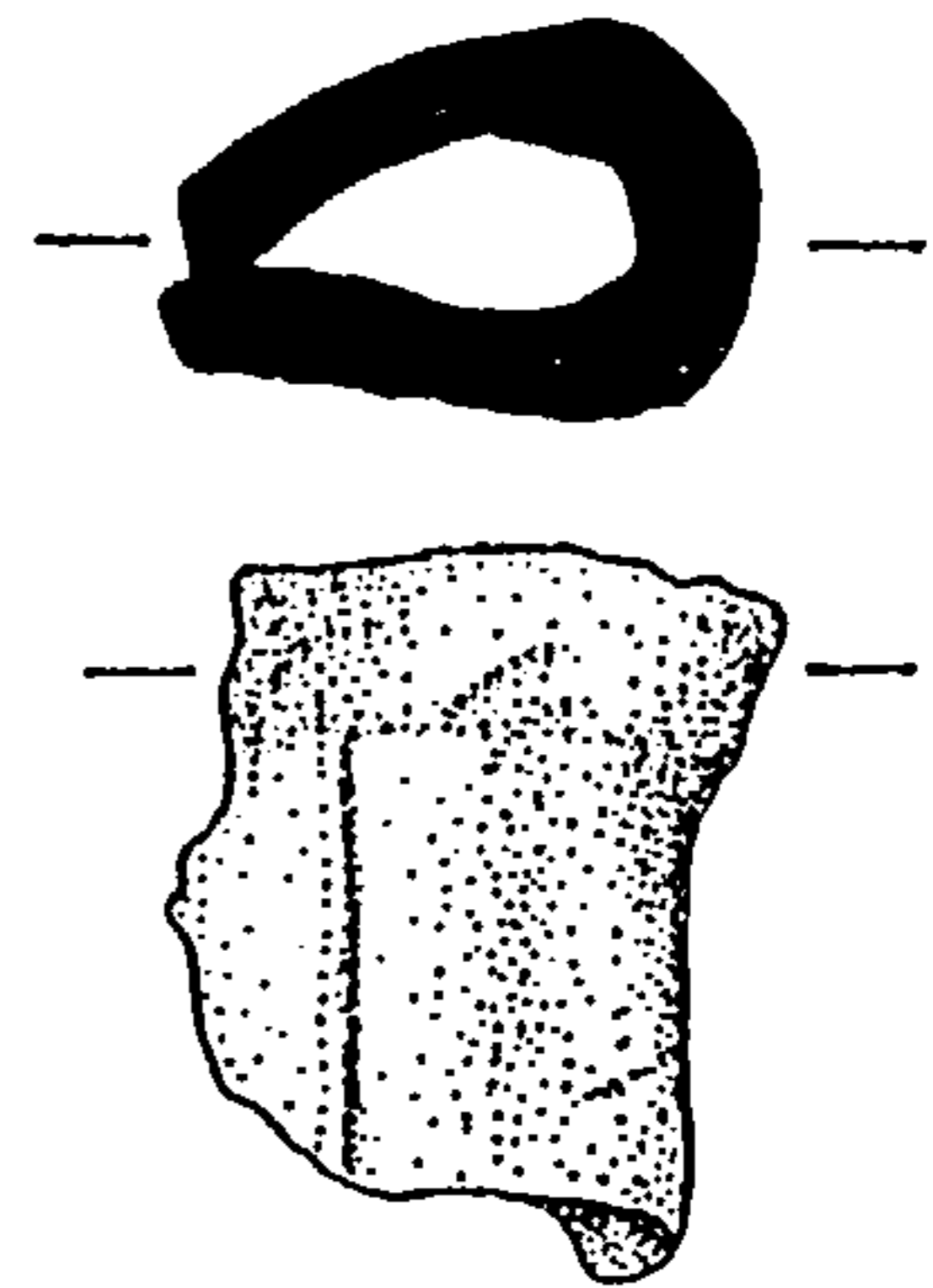
19/13



19/14

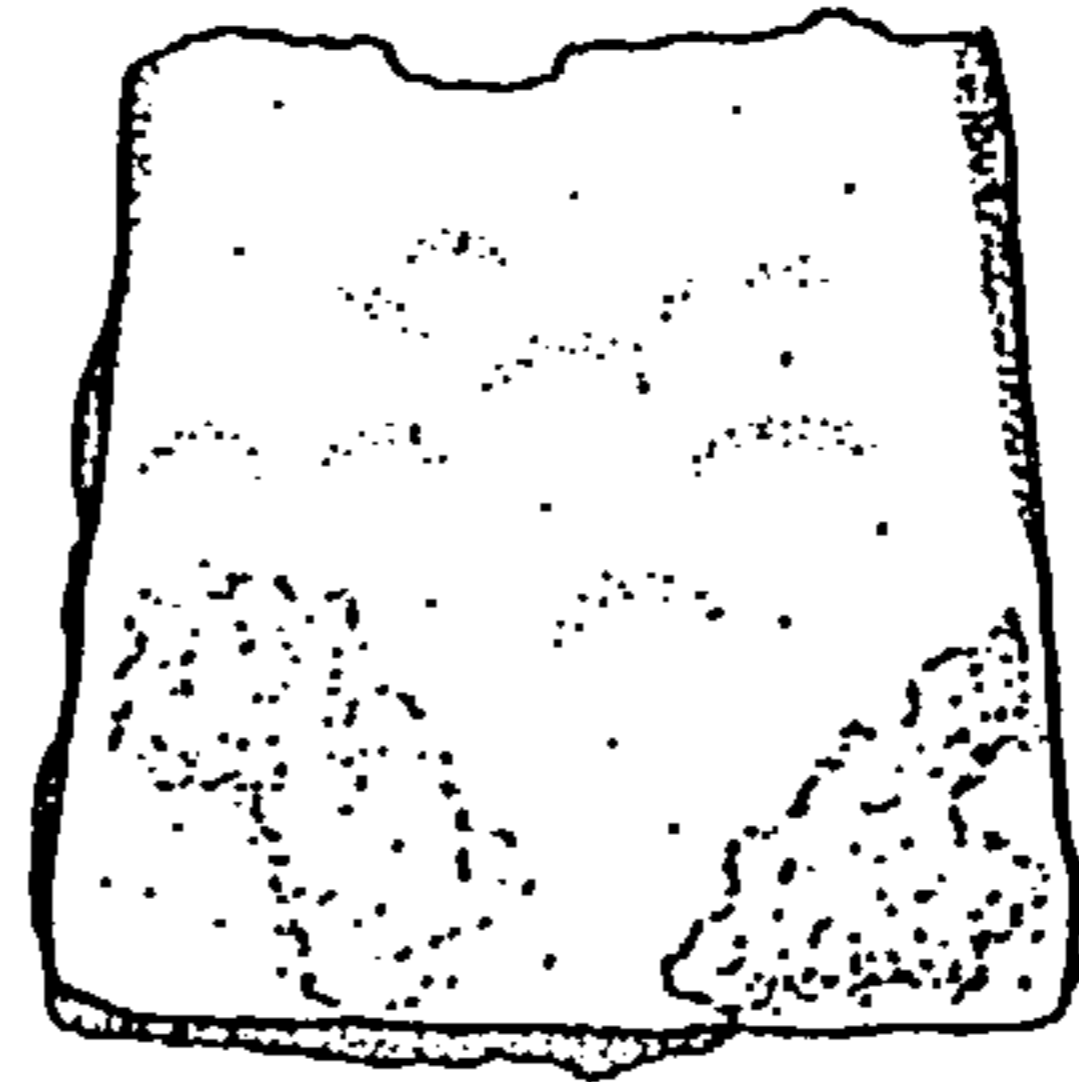
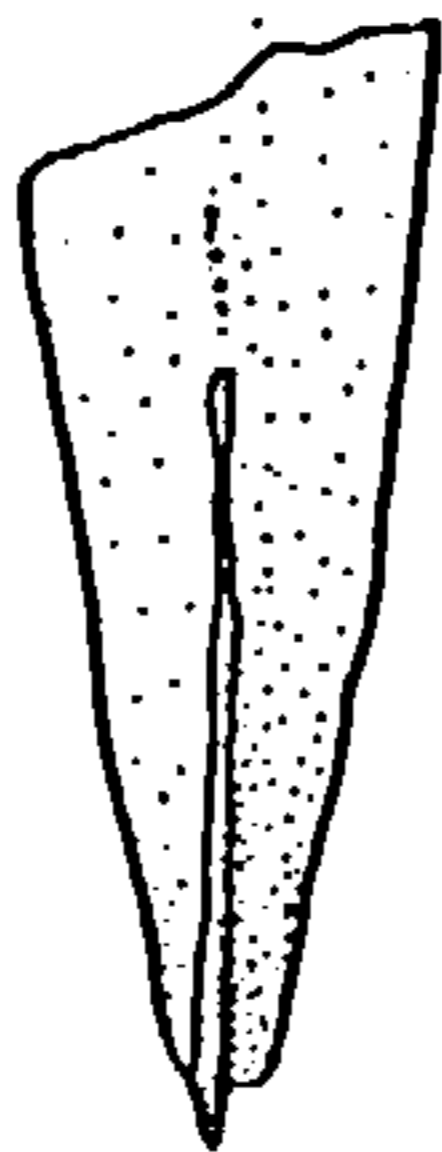


19/15



0 2cm

19/16



19/17



19/18



19/19

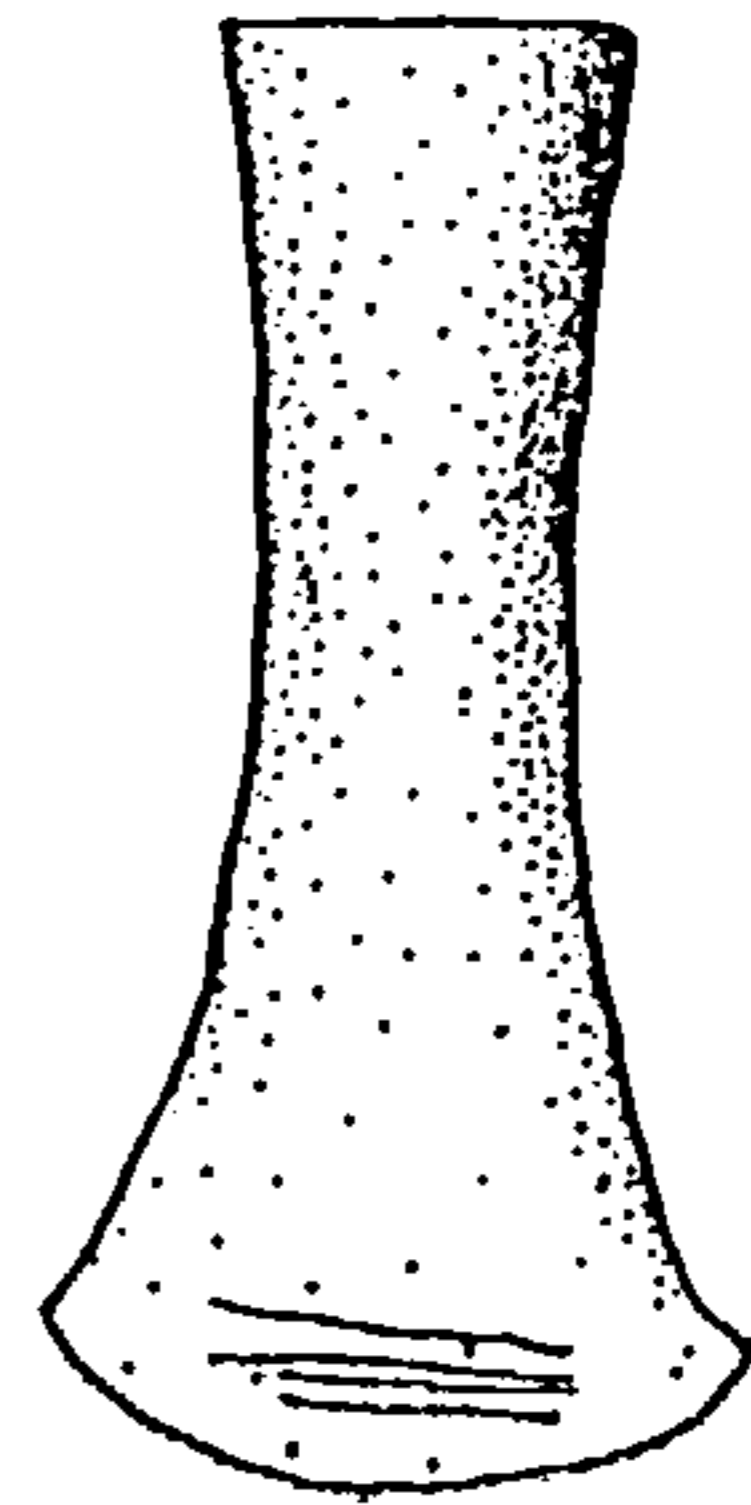
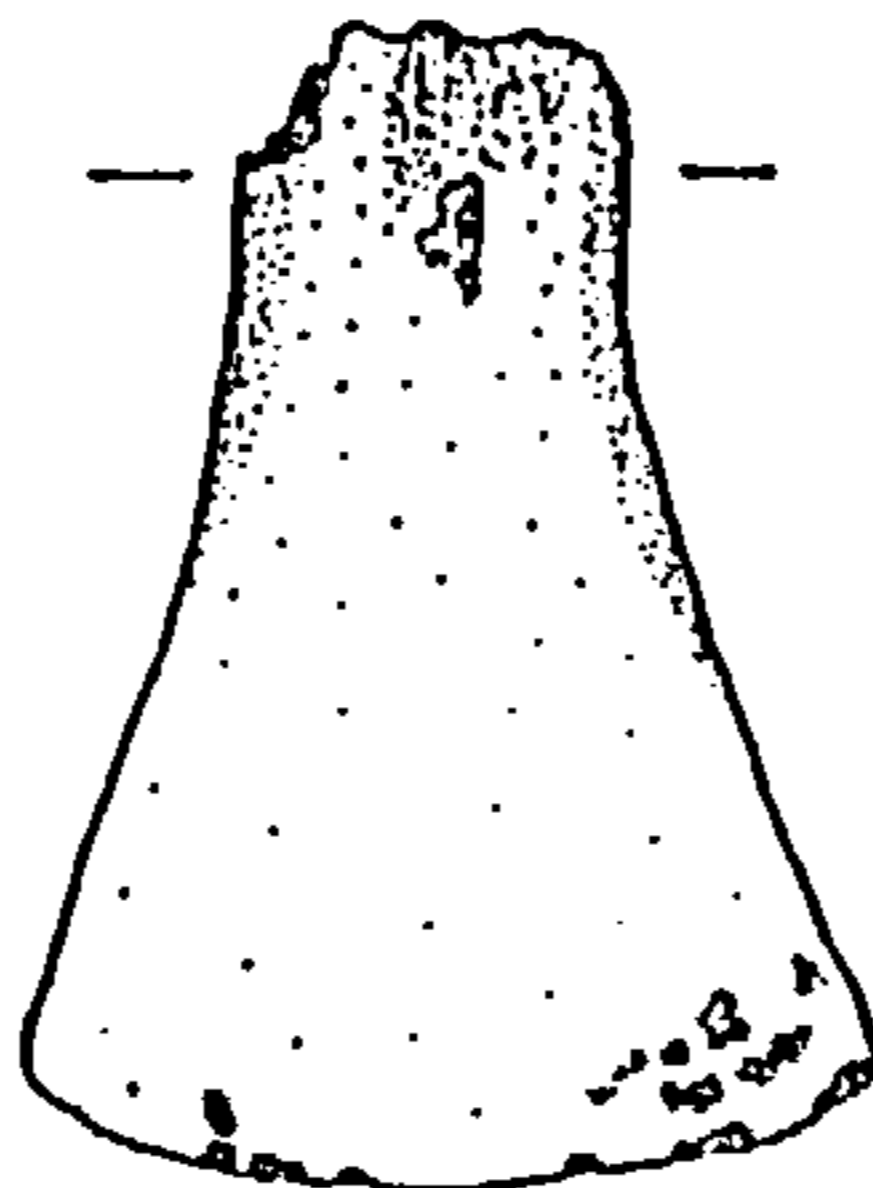
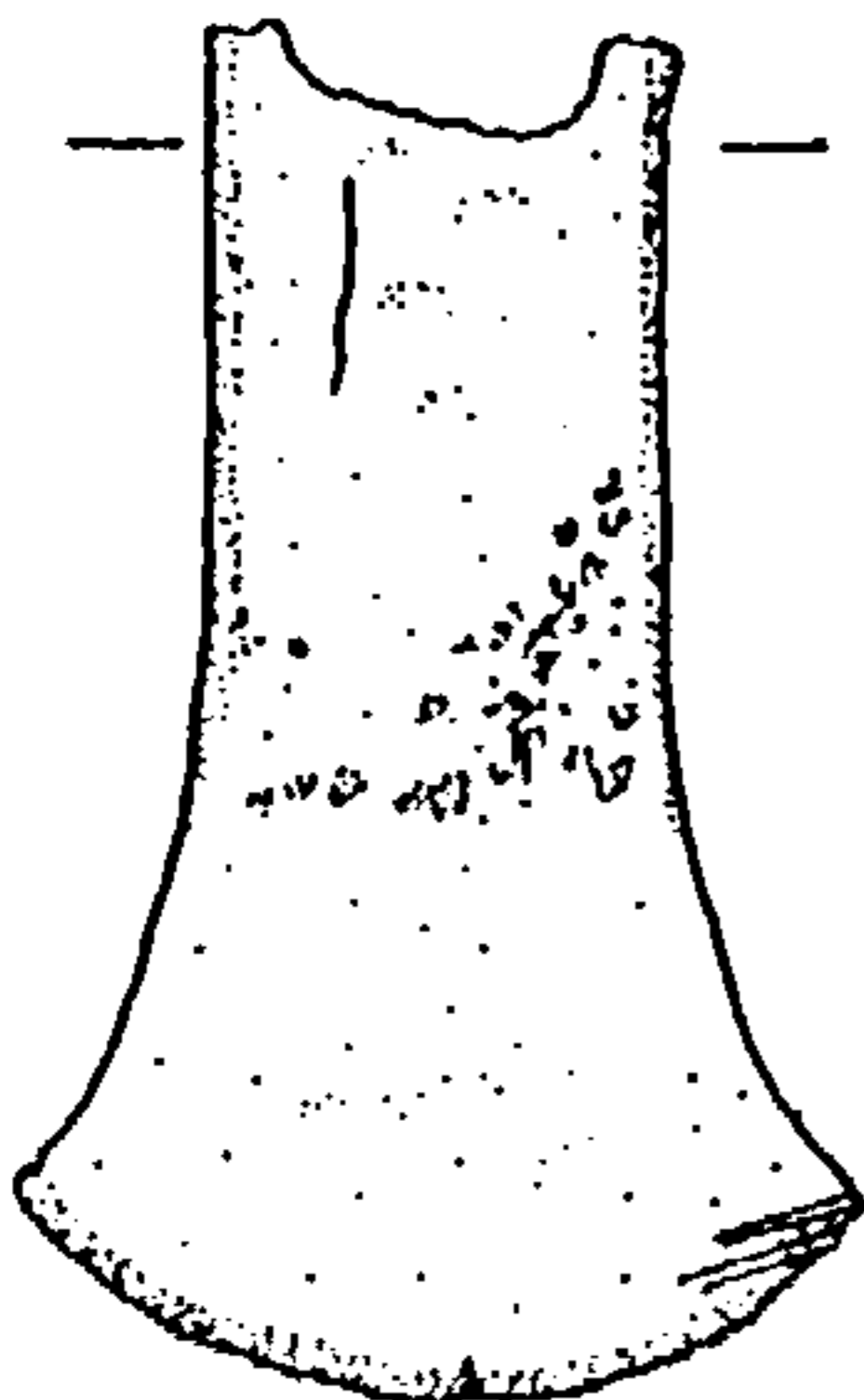
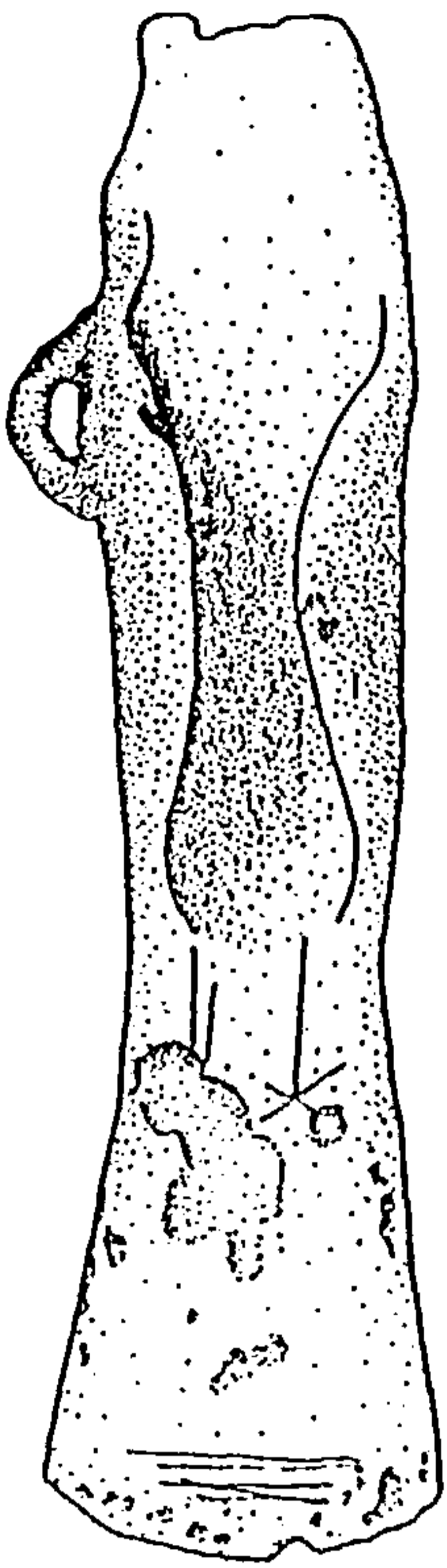
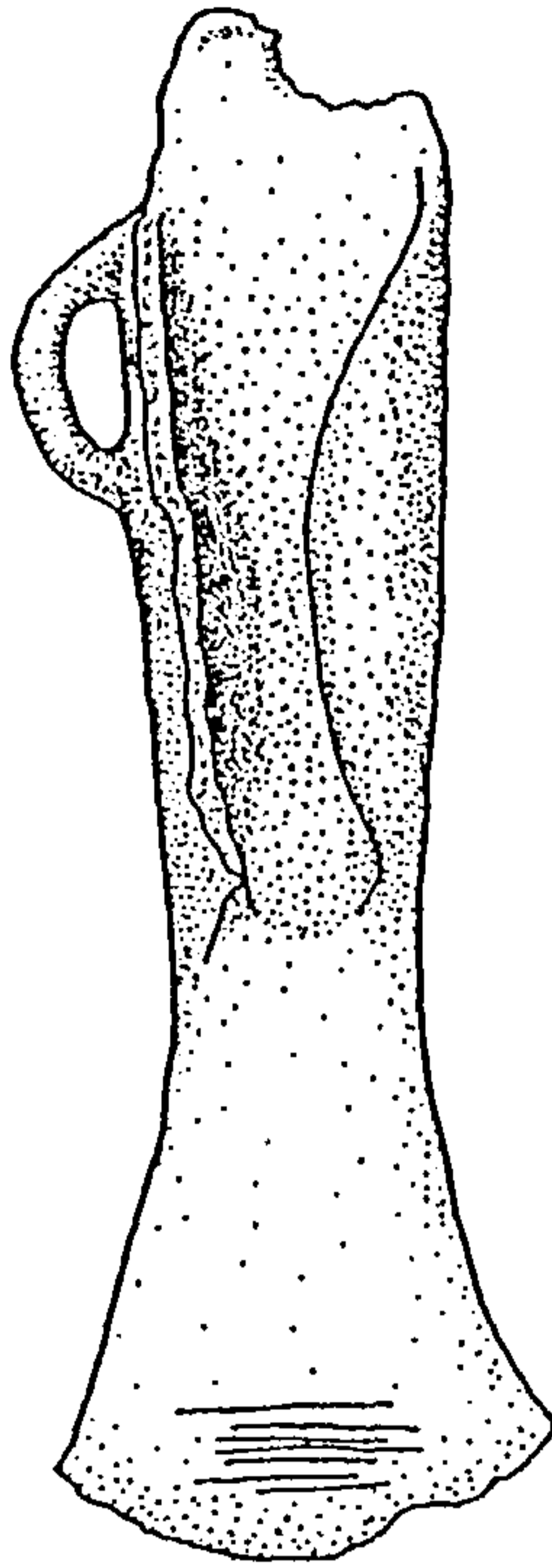


Fig. 42: The Minnis Bay Hoard (Ref. No. 19): Socketed Axe Fragments and Socketed Chisels

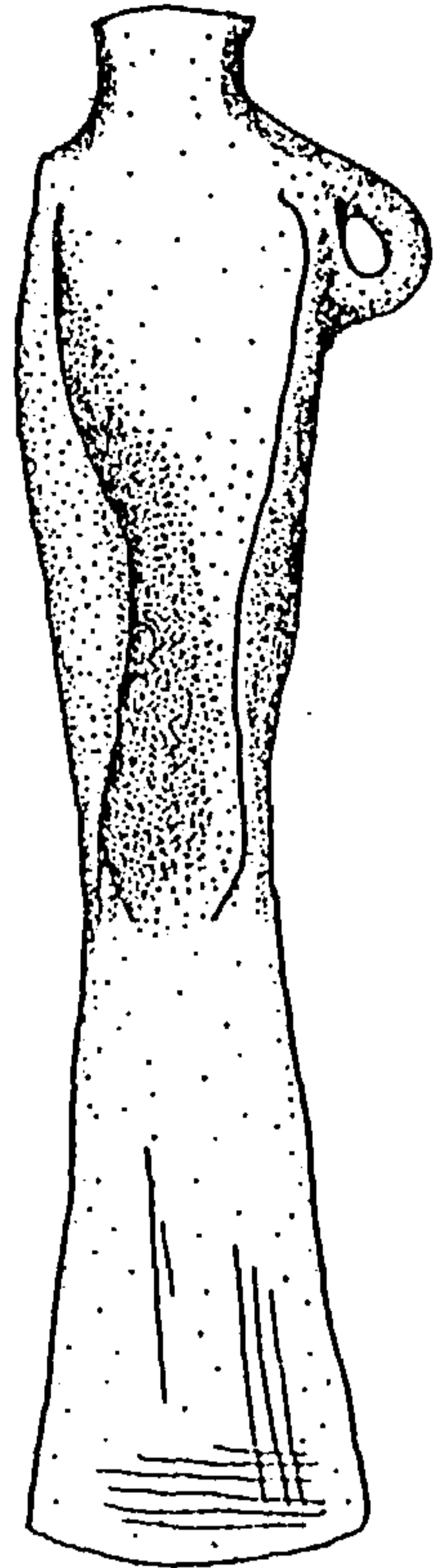
19/20



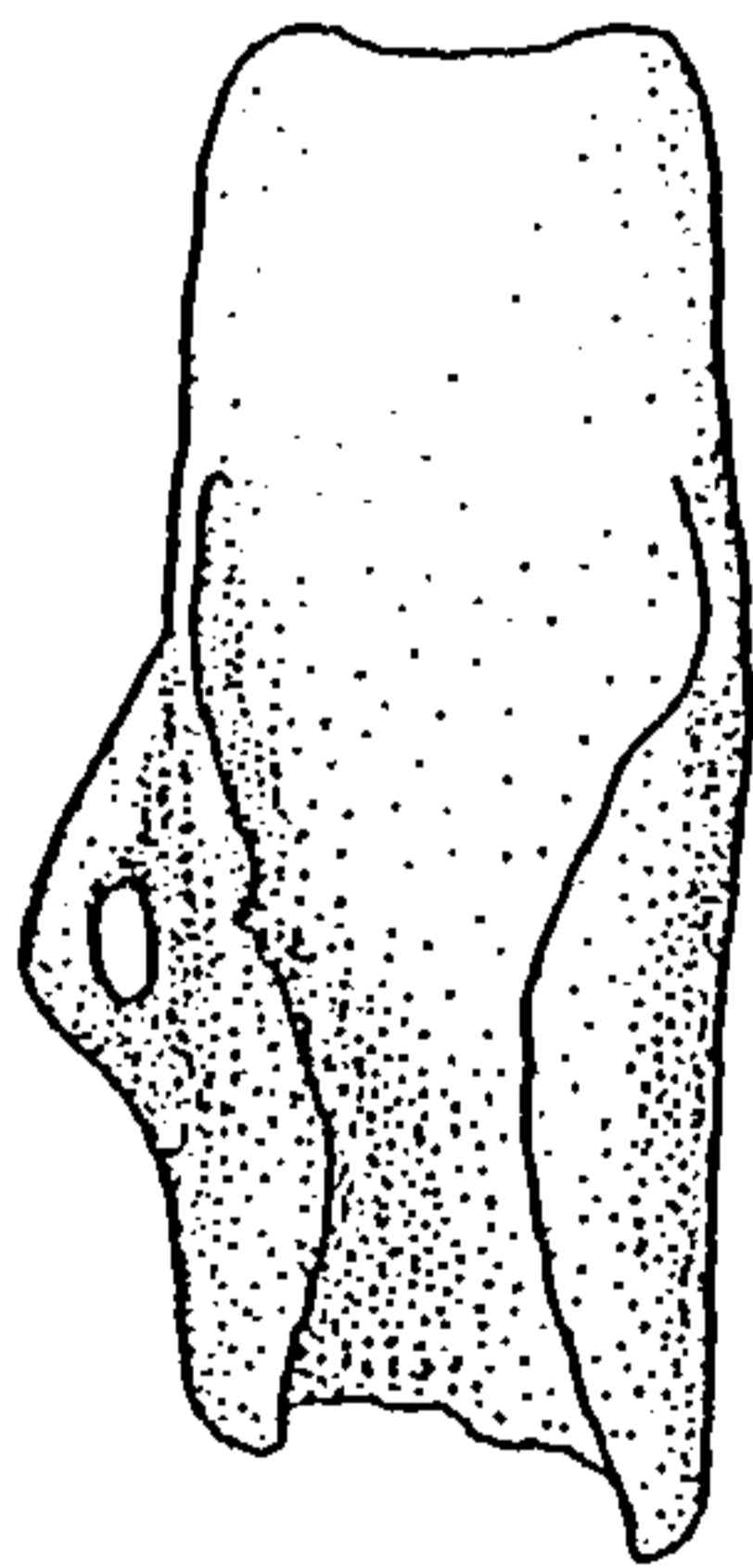
19/21



19/22



19/23



19/24

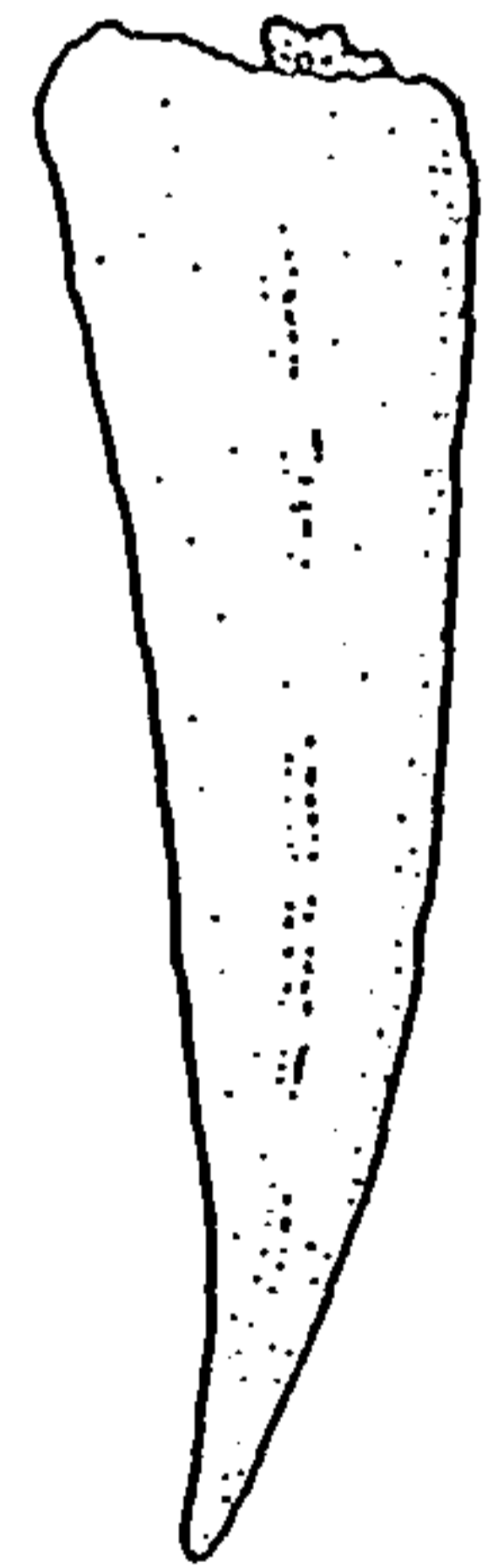
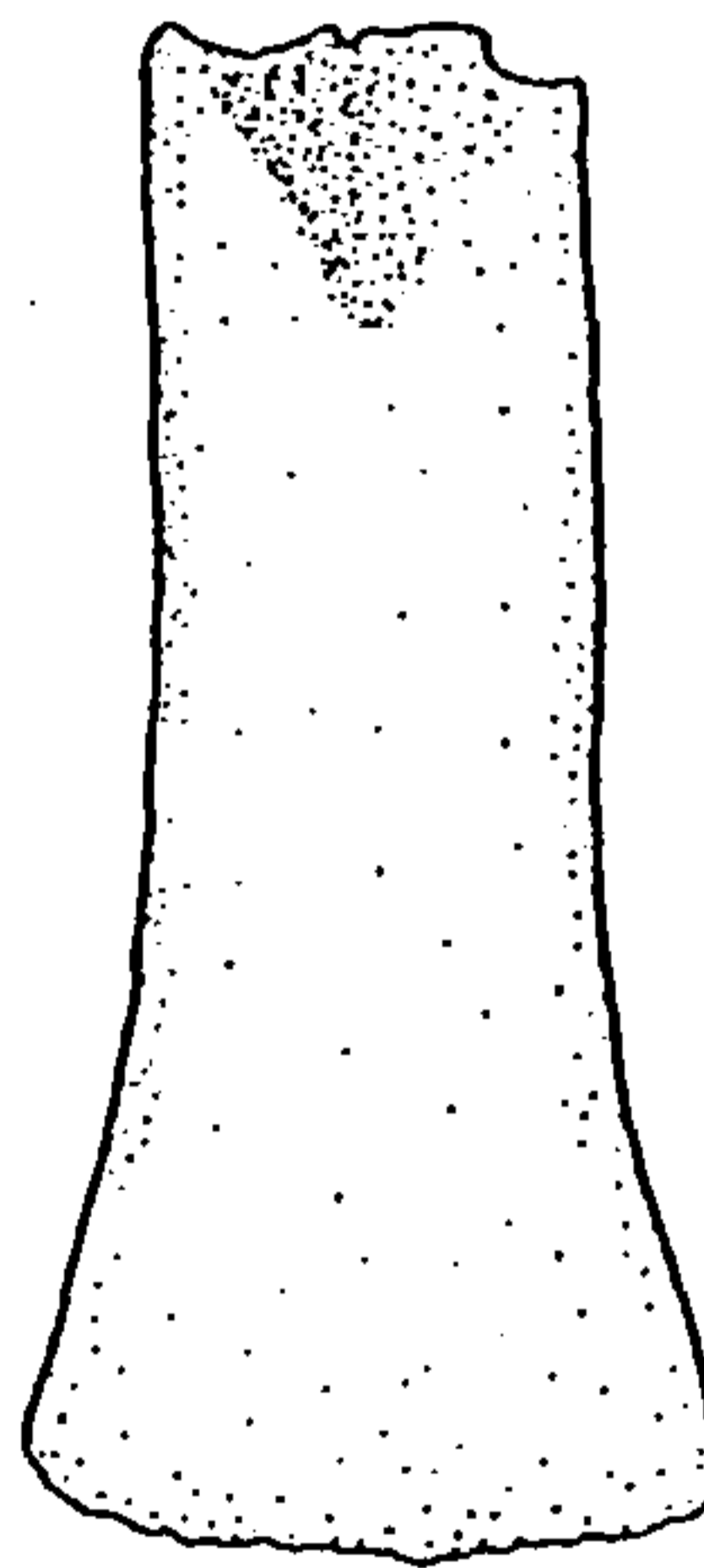
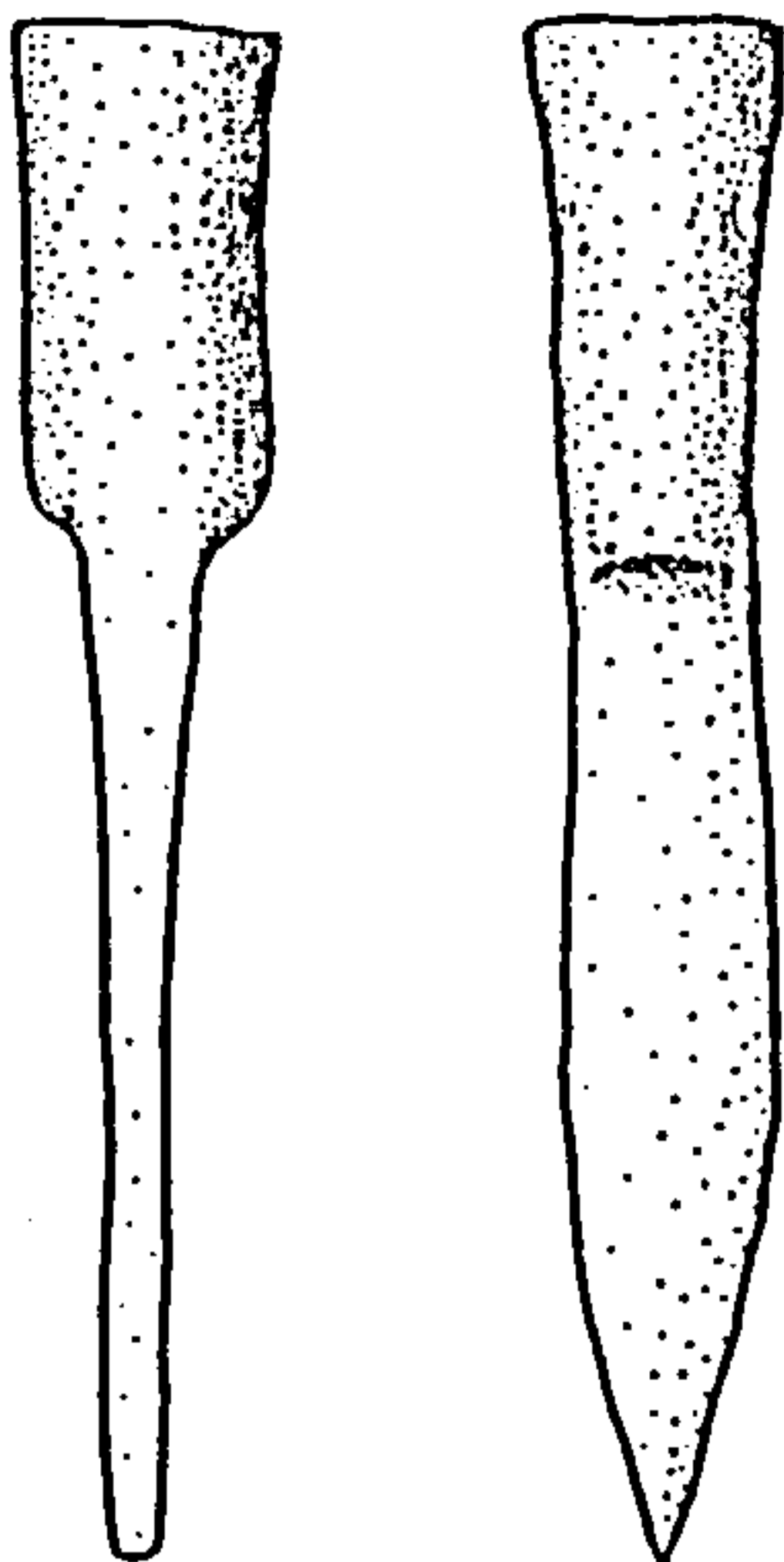
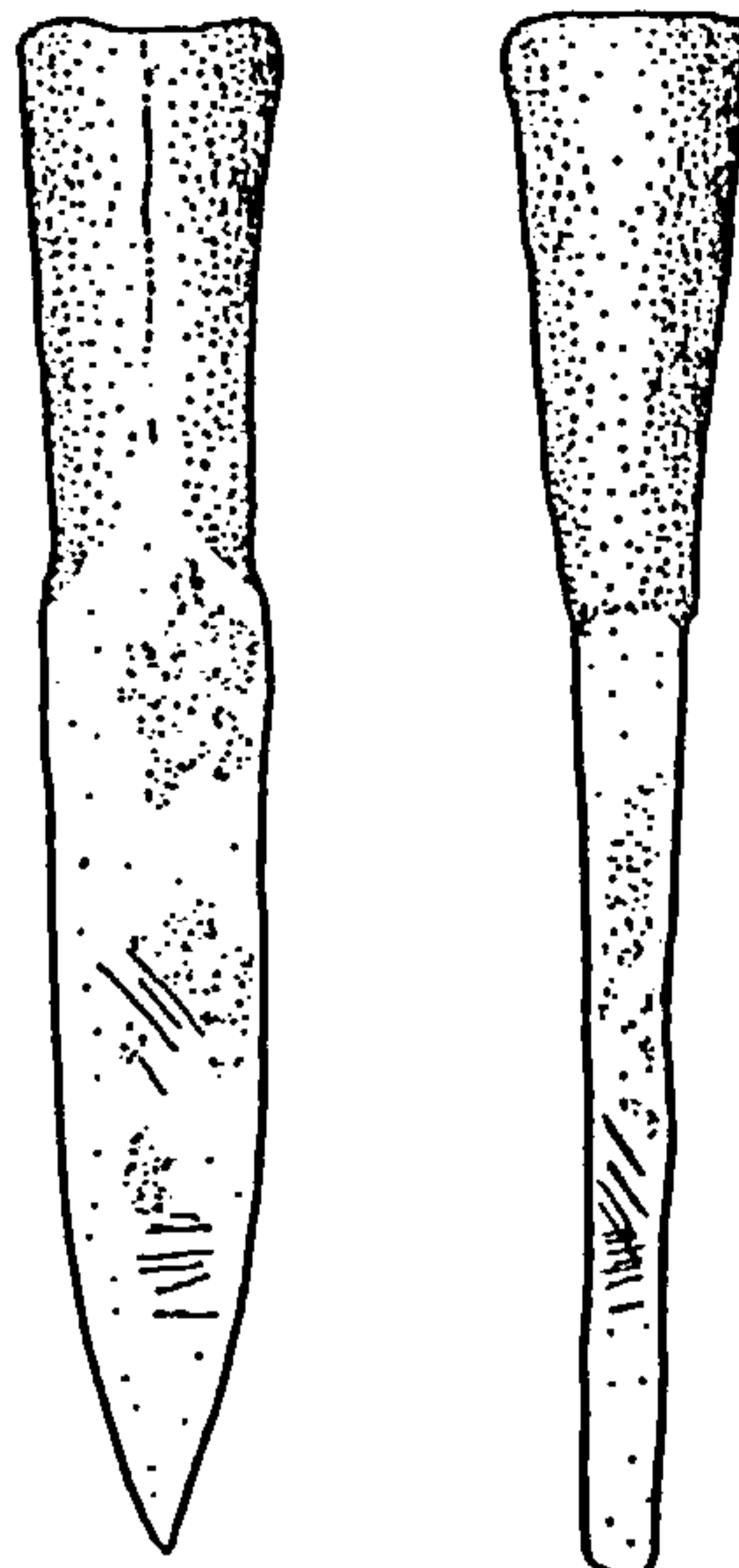


Fig. 43: The Minnis Bay Hoard (Ref. No. 19): Winged Axes

19/25

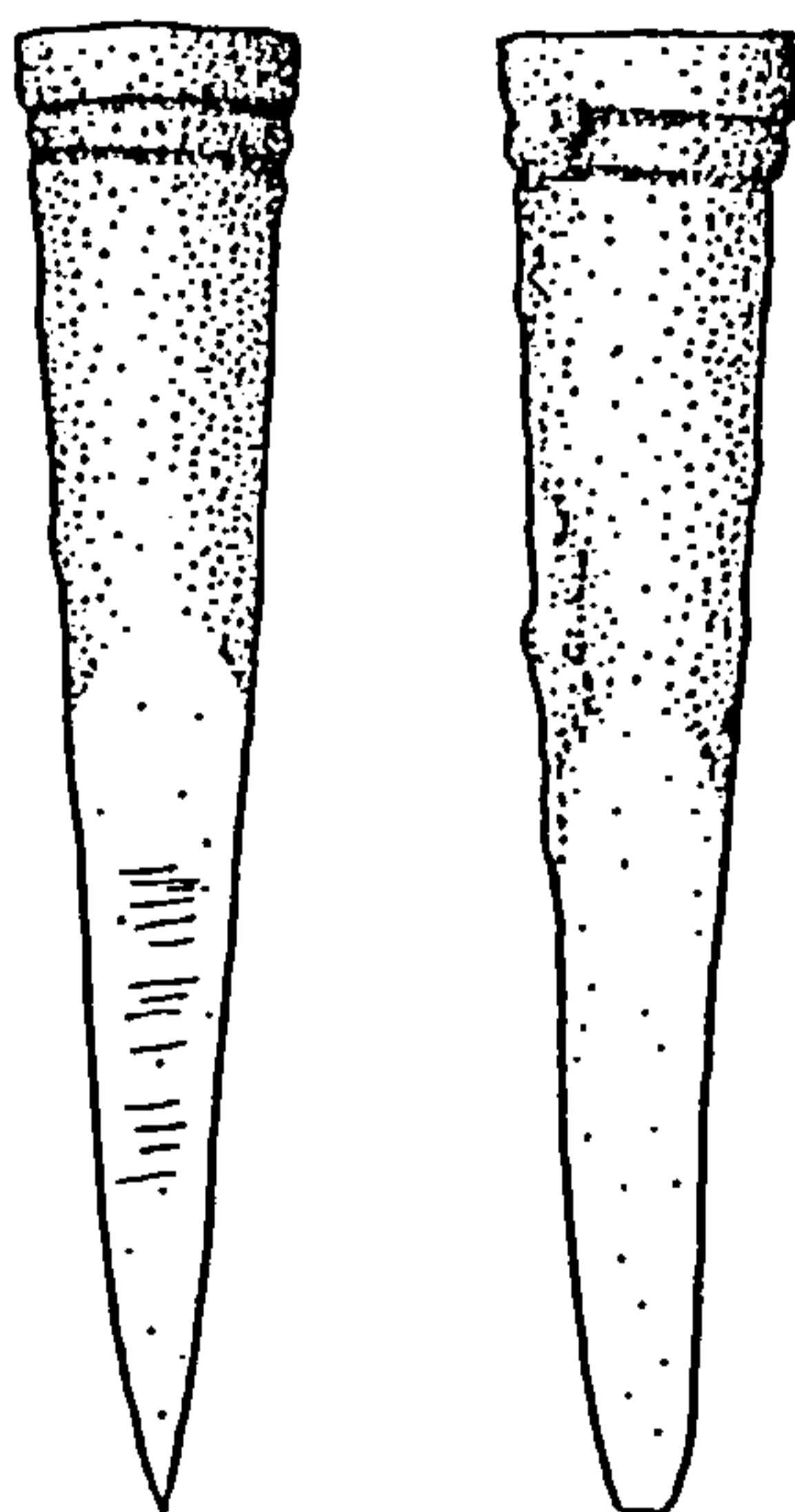


19/26

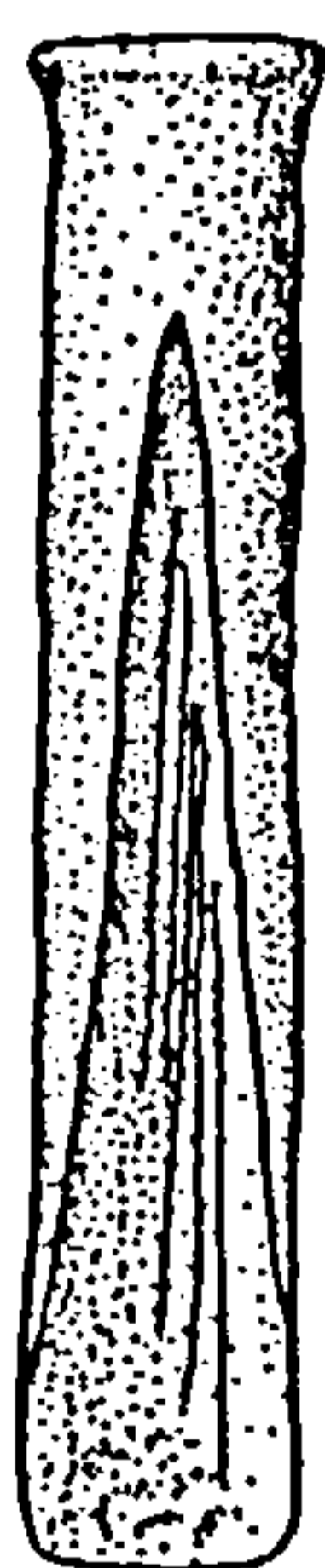


0 2cm

19/27



19/28



19/29

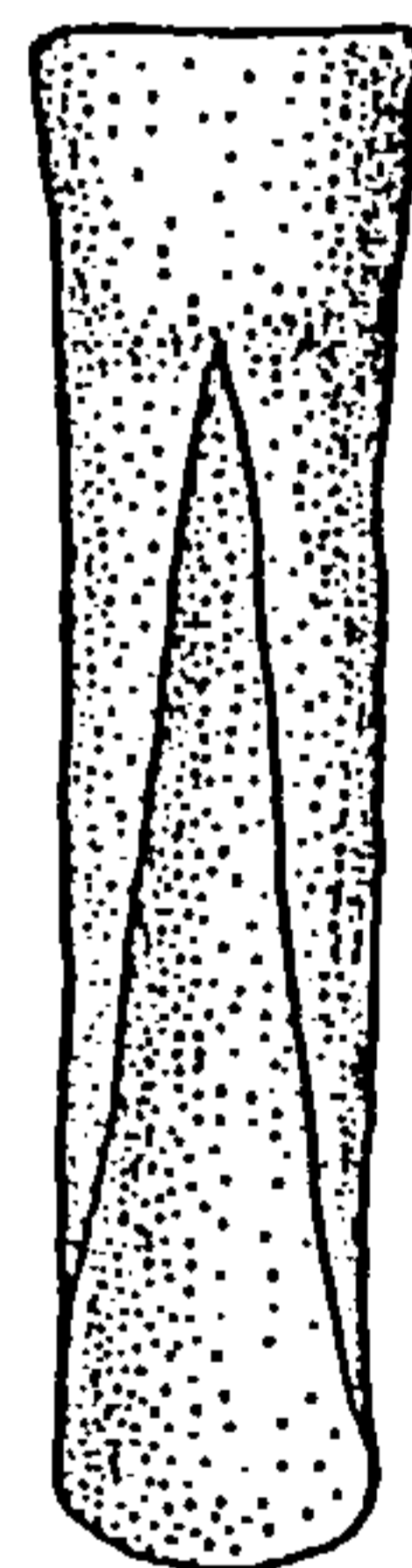
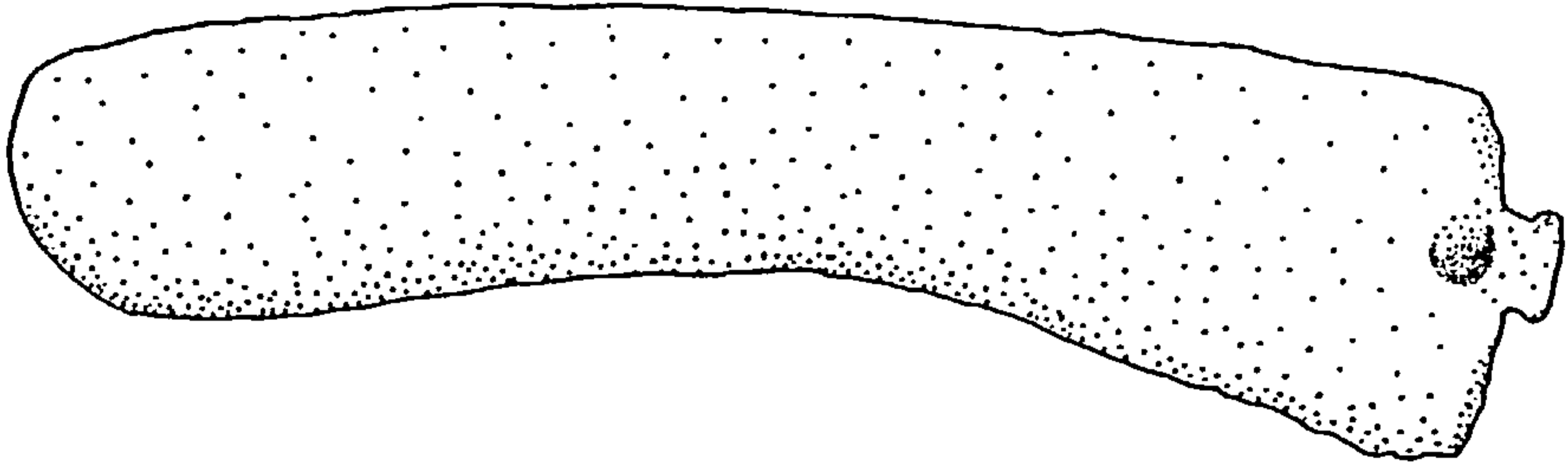
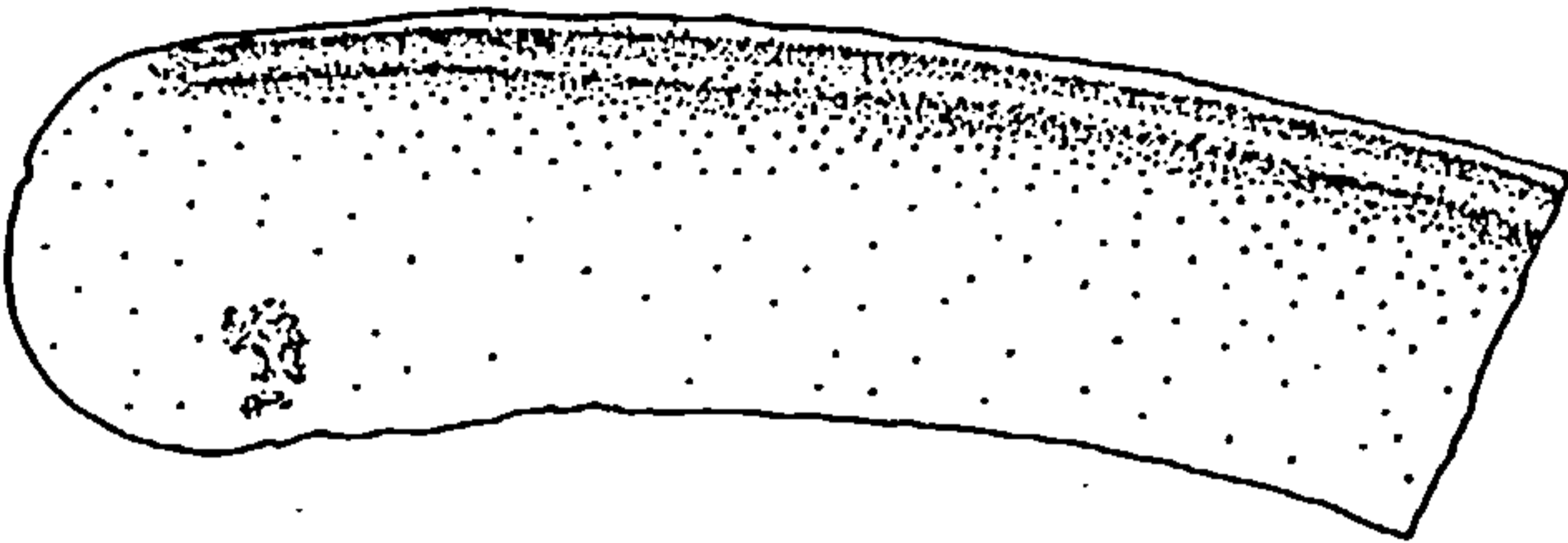


Fig. 44: The Minnis Bay Hoard (Ref. No. 19): Mortising Chisels, Punch and Gouges

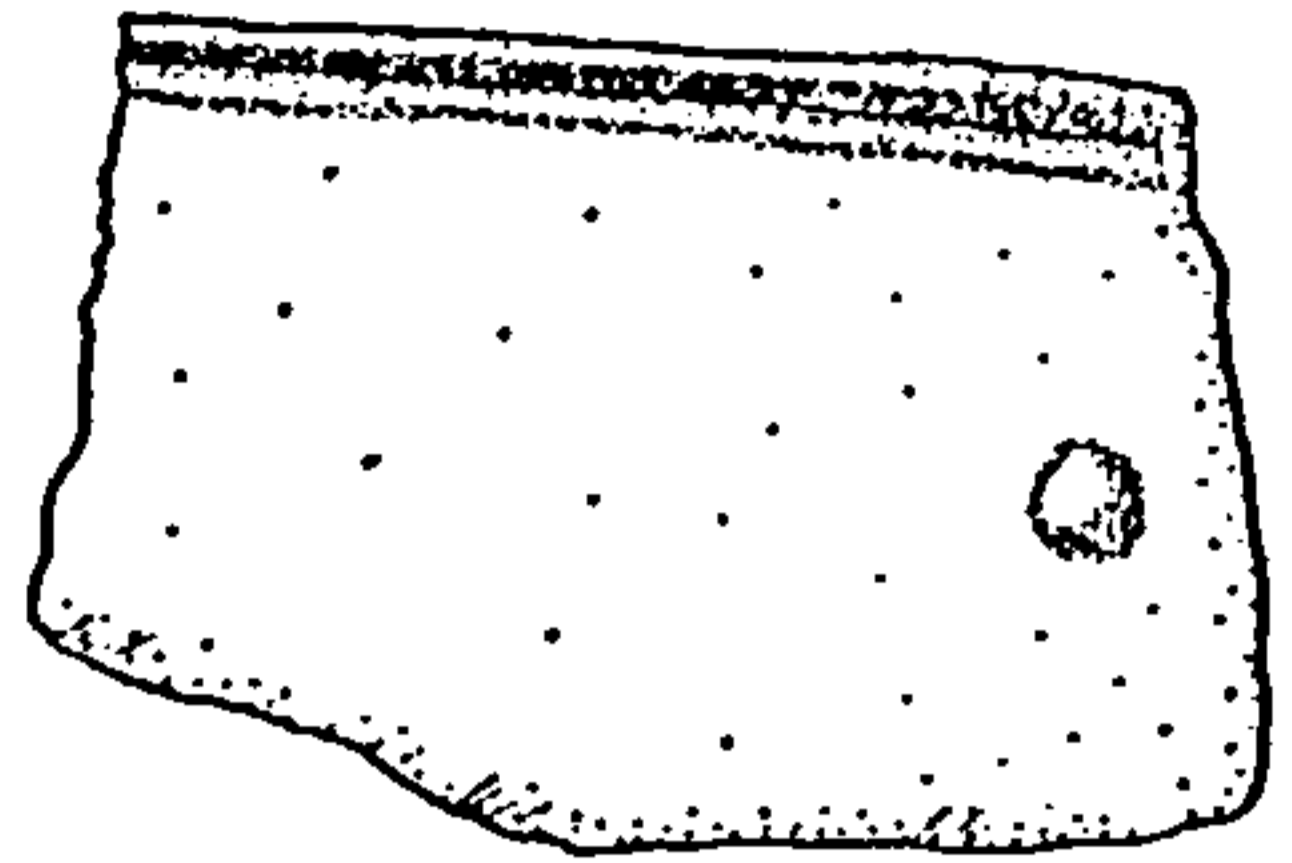
19/30



19/31

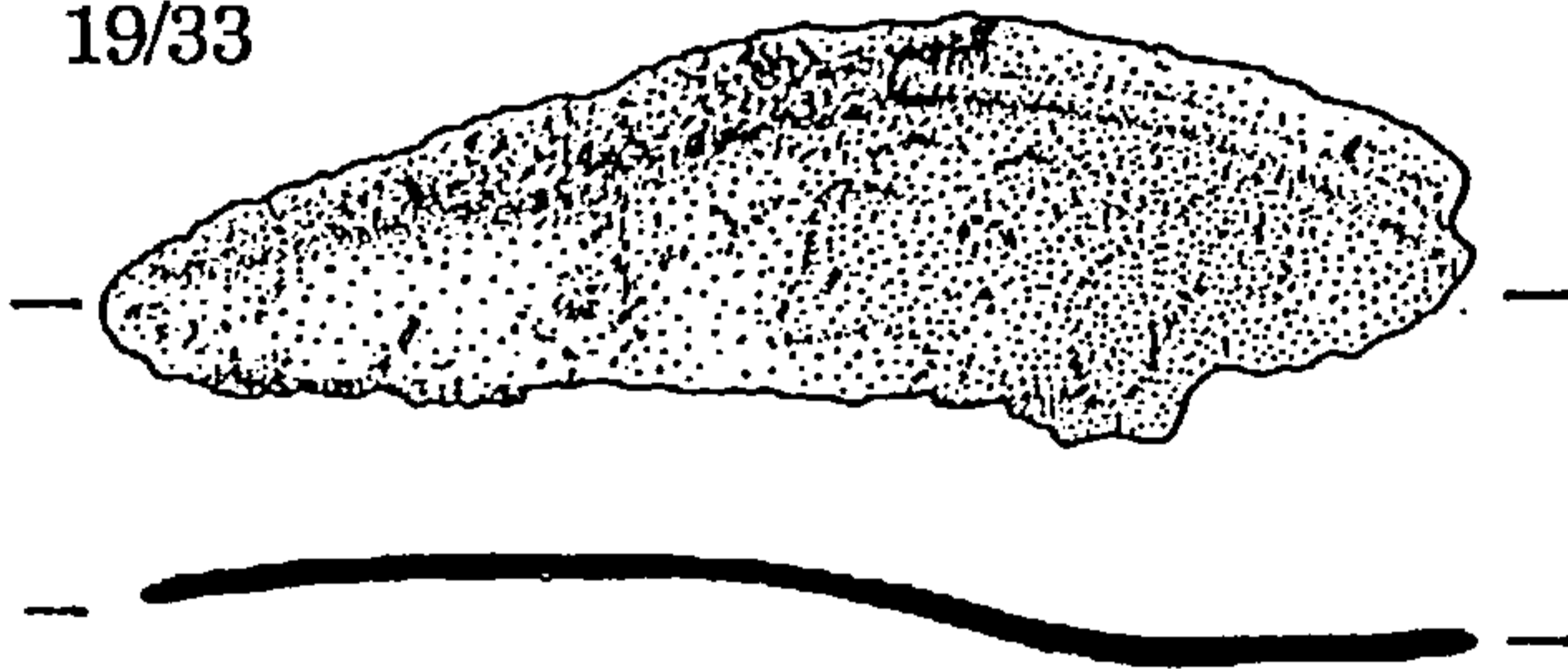


19/32

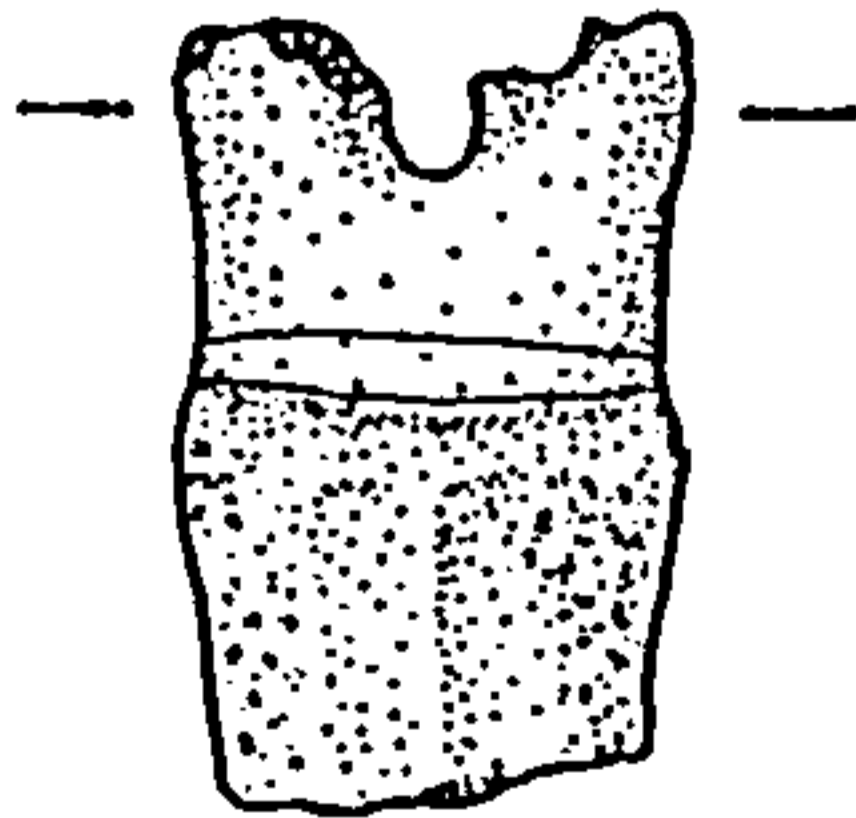


19/33

0 2cm



19/34



19/35



19/36

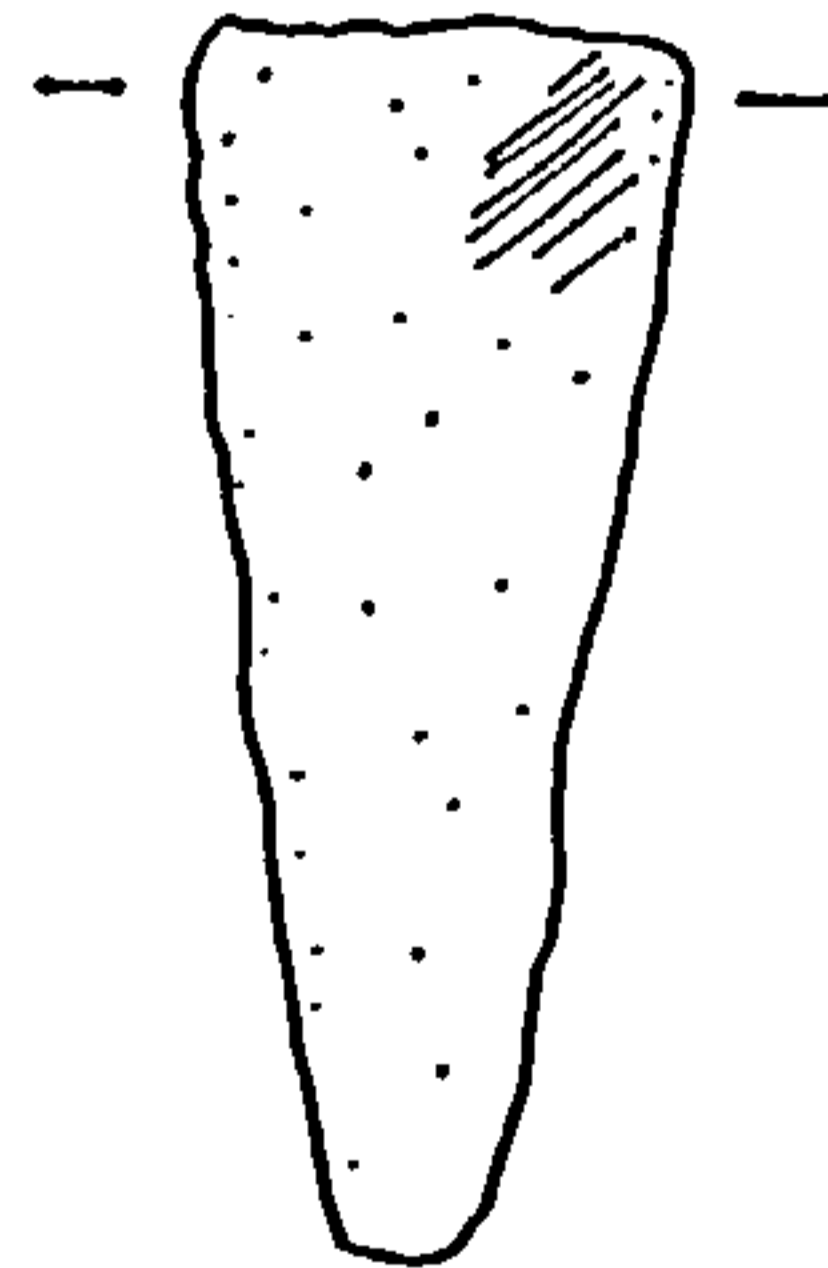


Fig. 45: The Minnis Bay Hoard (Ref. No. 19): Sickles and Knife Fragments

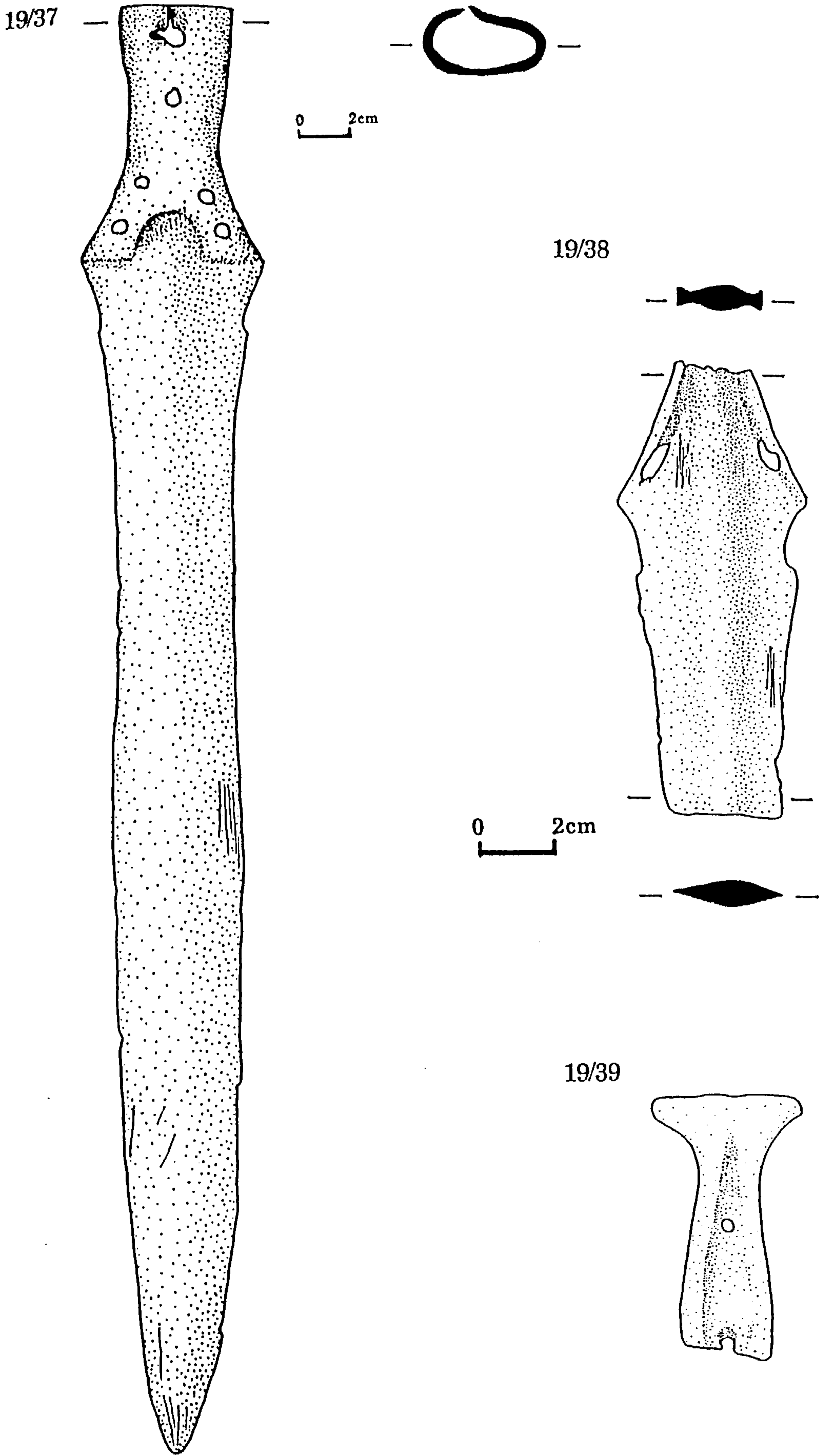
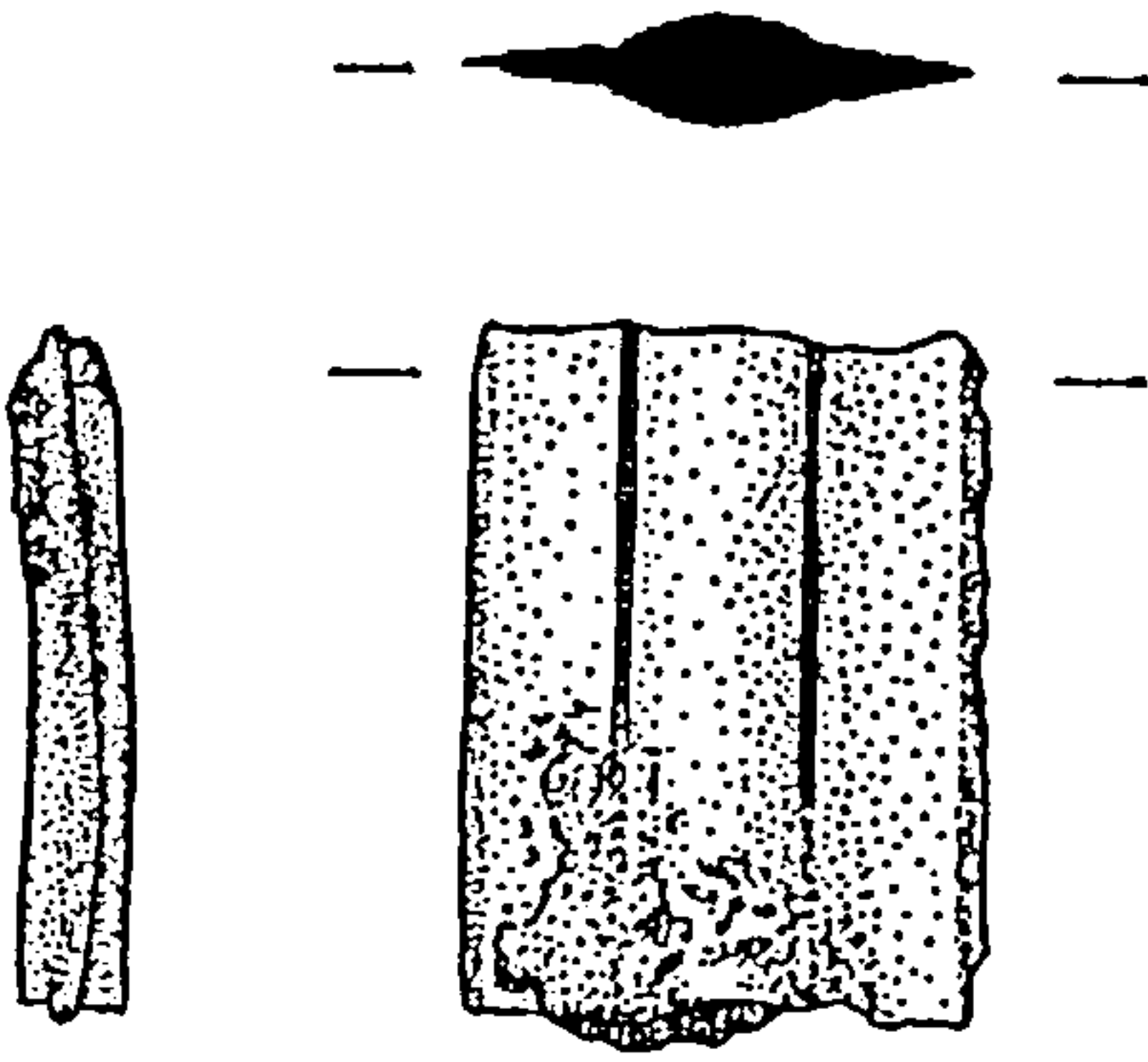
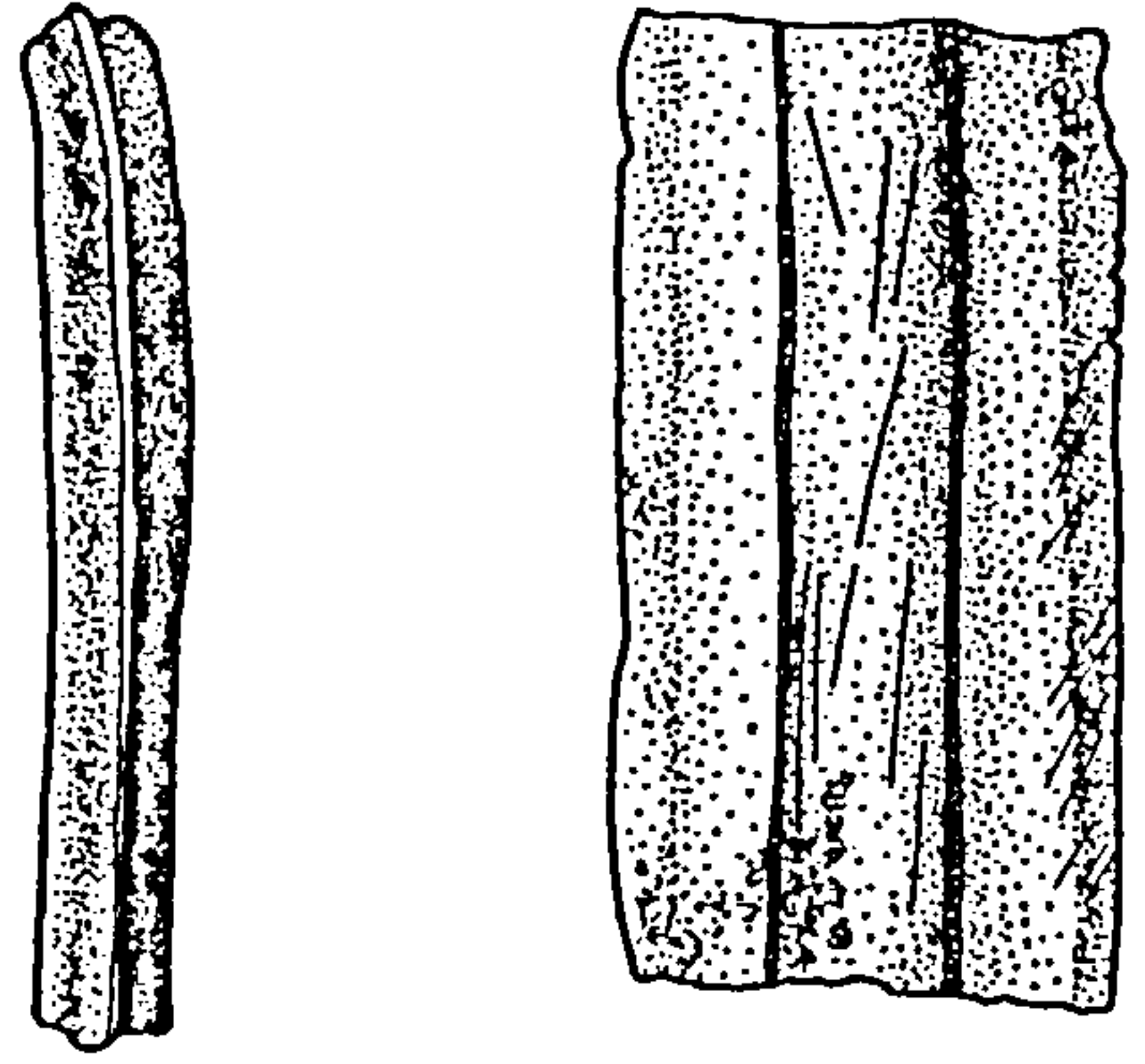


Fig. 46: The Minnis Bay Hoard (Ref. No. 19): Socketed Sword and Sword Hilt Fragments

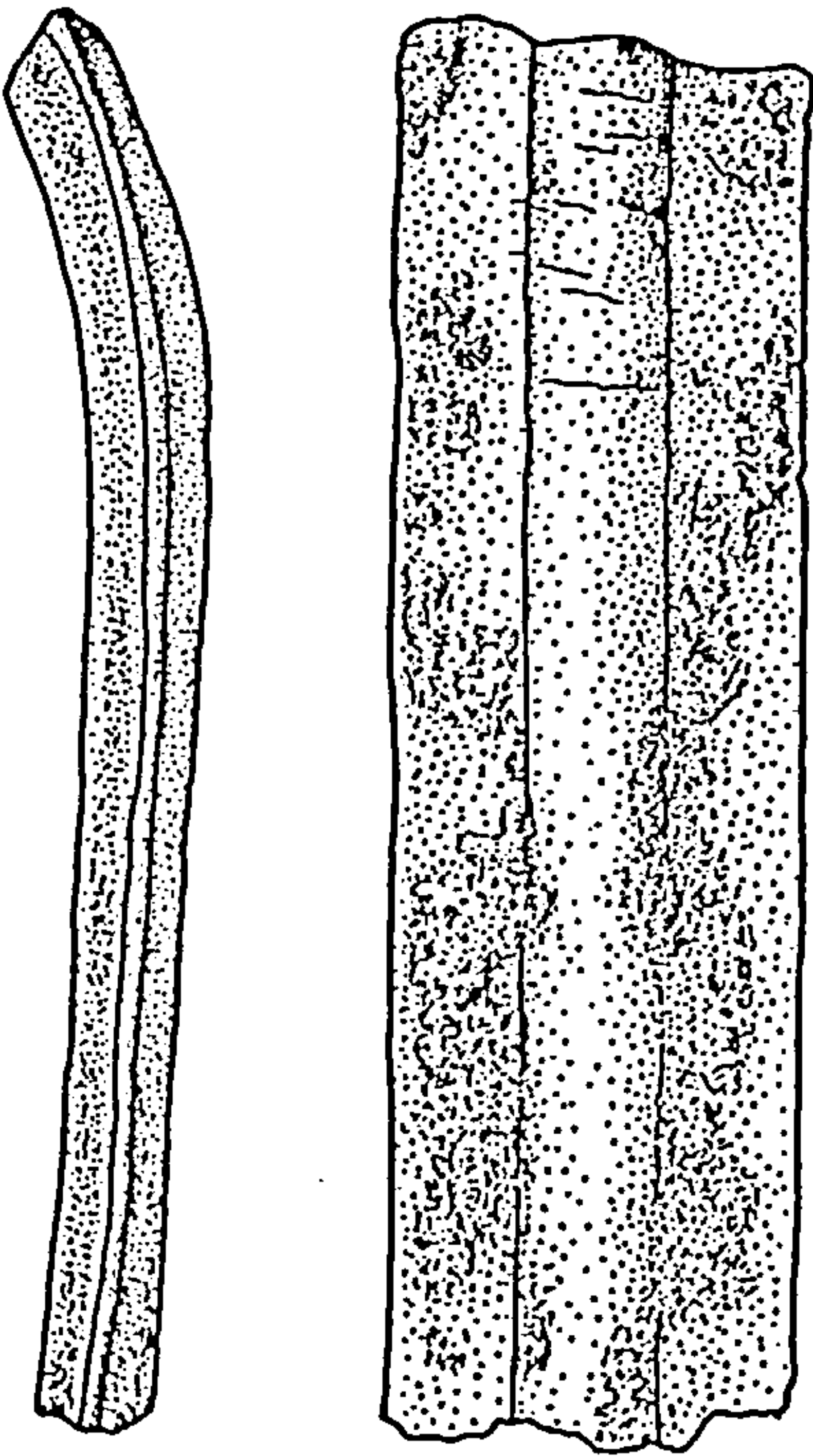
19/40



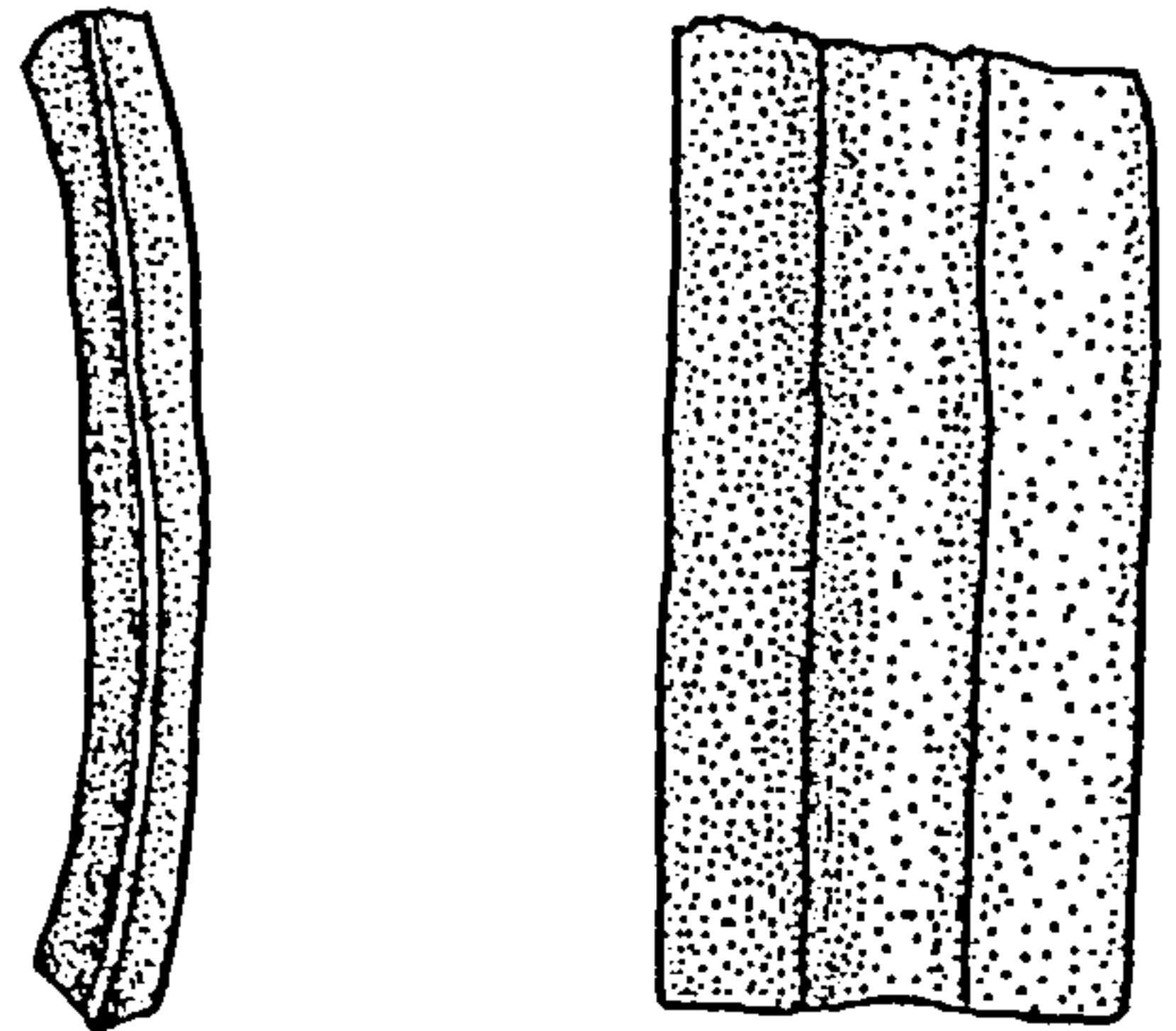
19/41



19/42



19/43



19/44

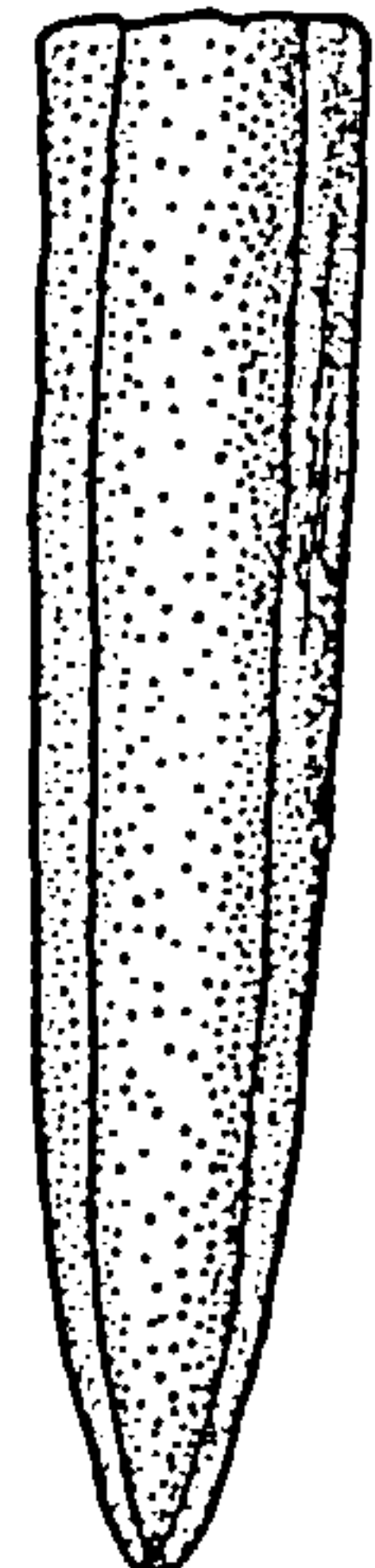
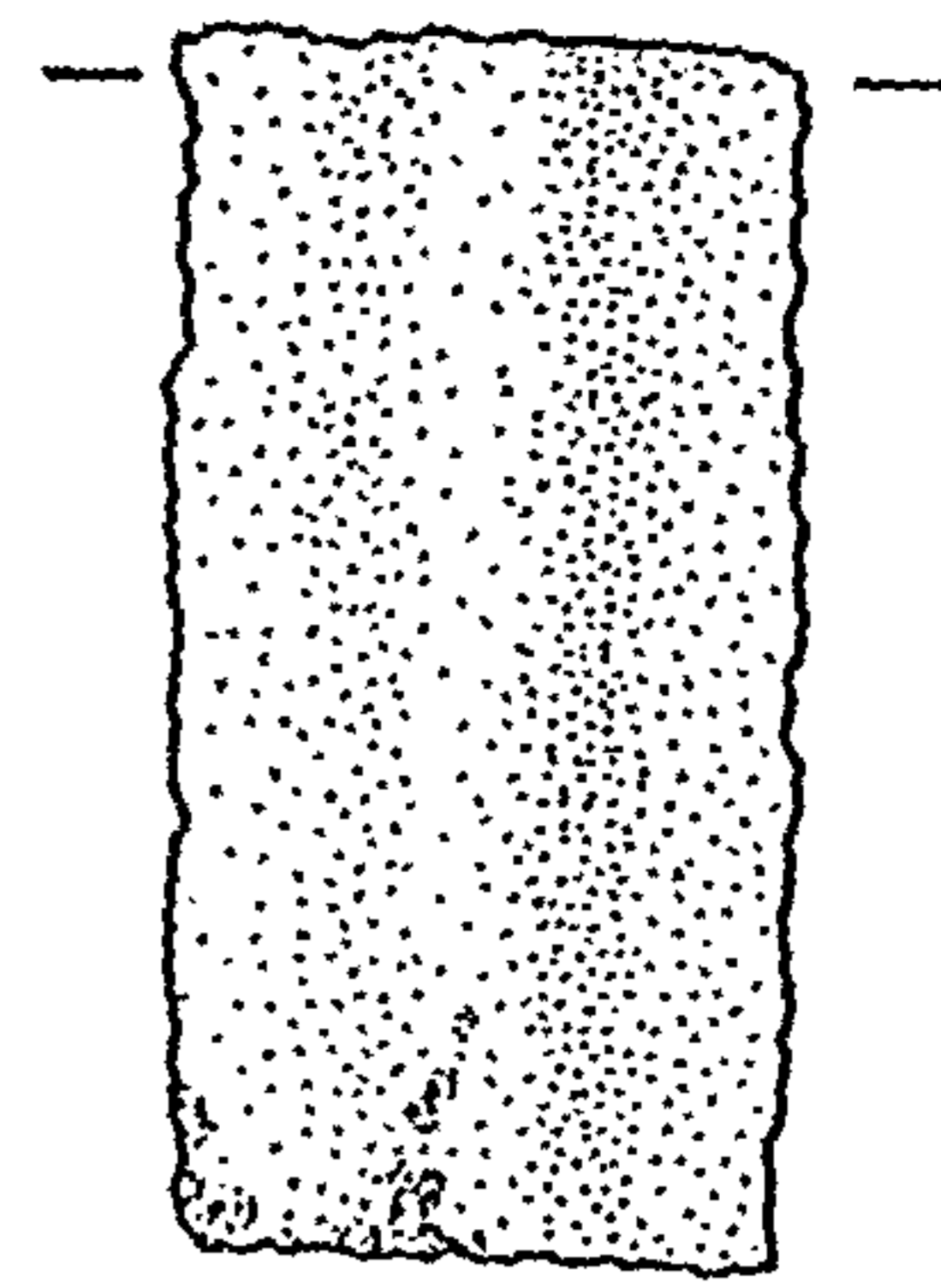
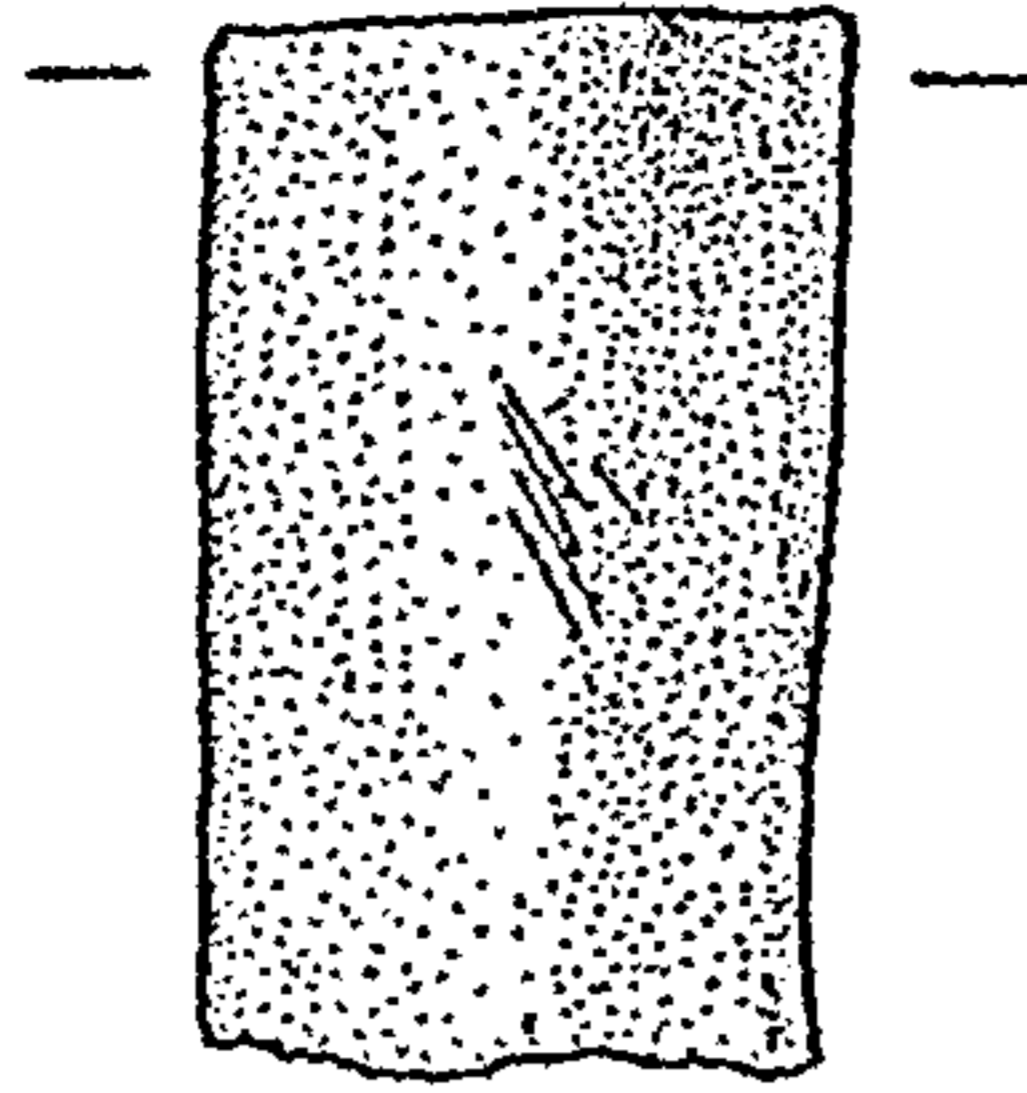


Fig. 47: The Minnis Bay Hoard (Ref. No. 19): Carp's Tongue Sword Fragments

19/45

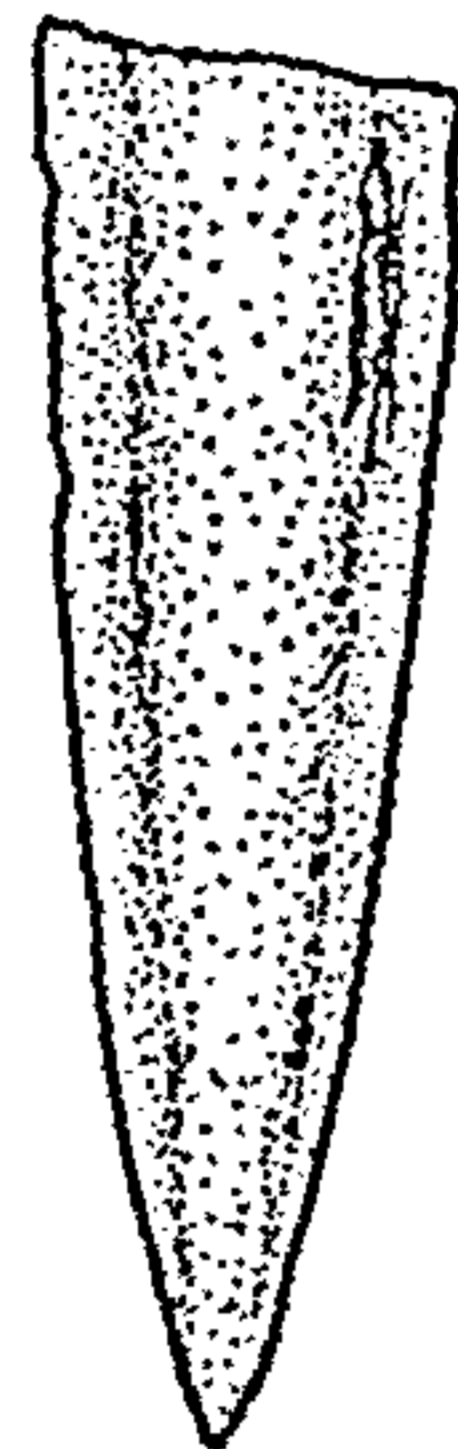


19/46

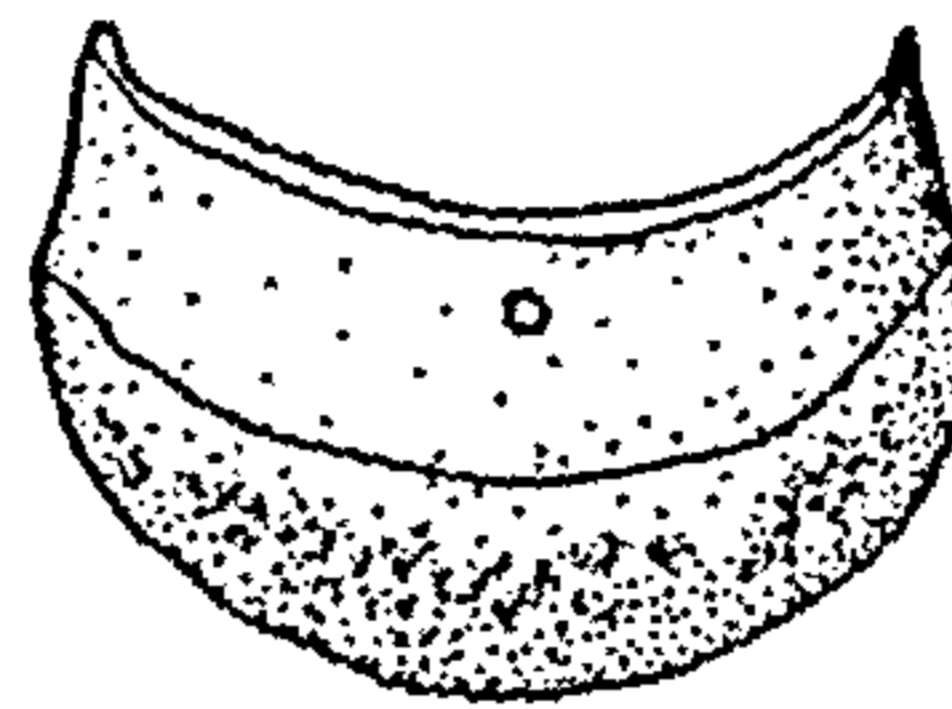


0 2cm

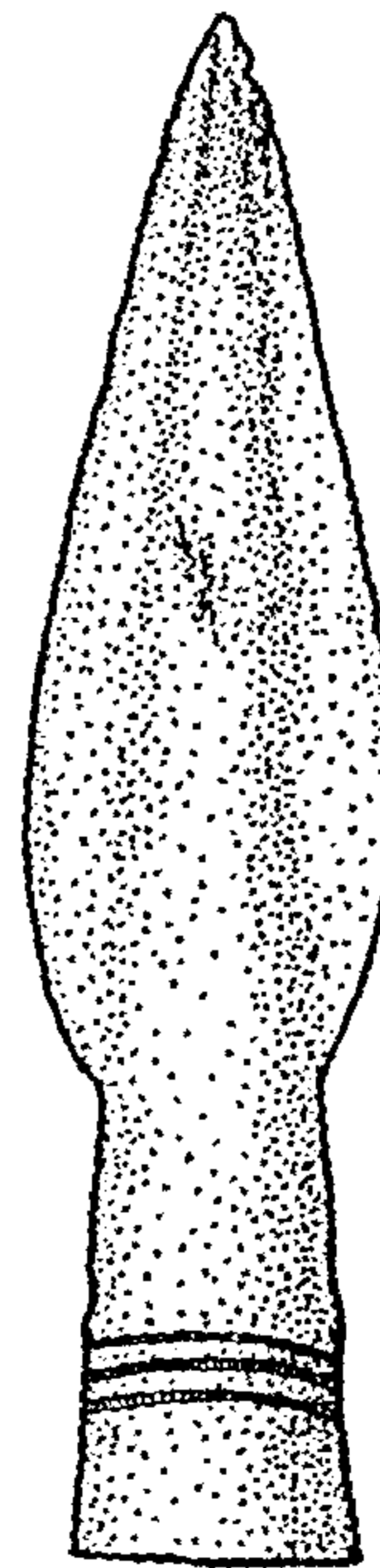
19/47



19/48



19/50



19/49

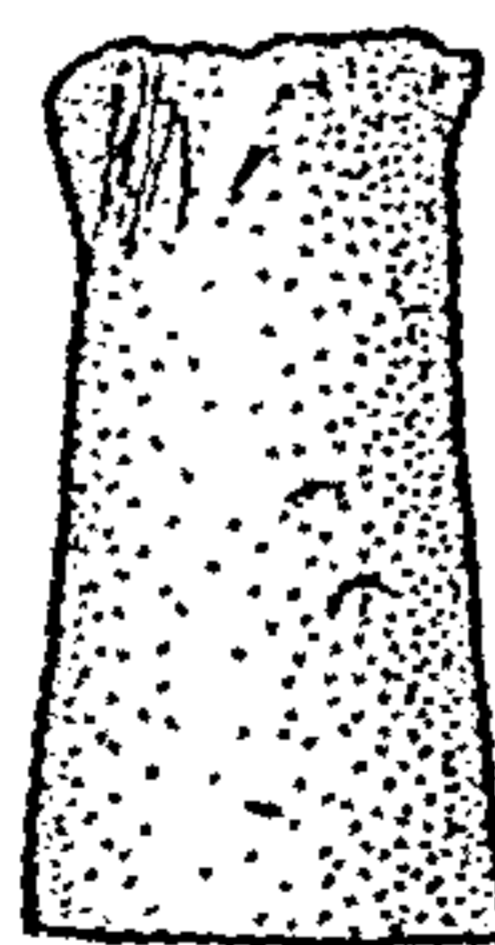


Fig. 48: The Minnis Bay Hoard (Ref. No. 19): Ewart Park Sword Fragments, Chape and Spearheads

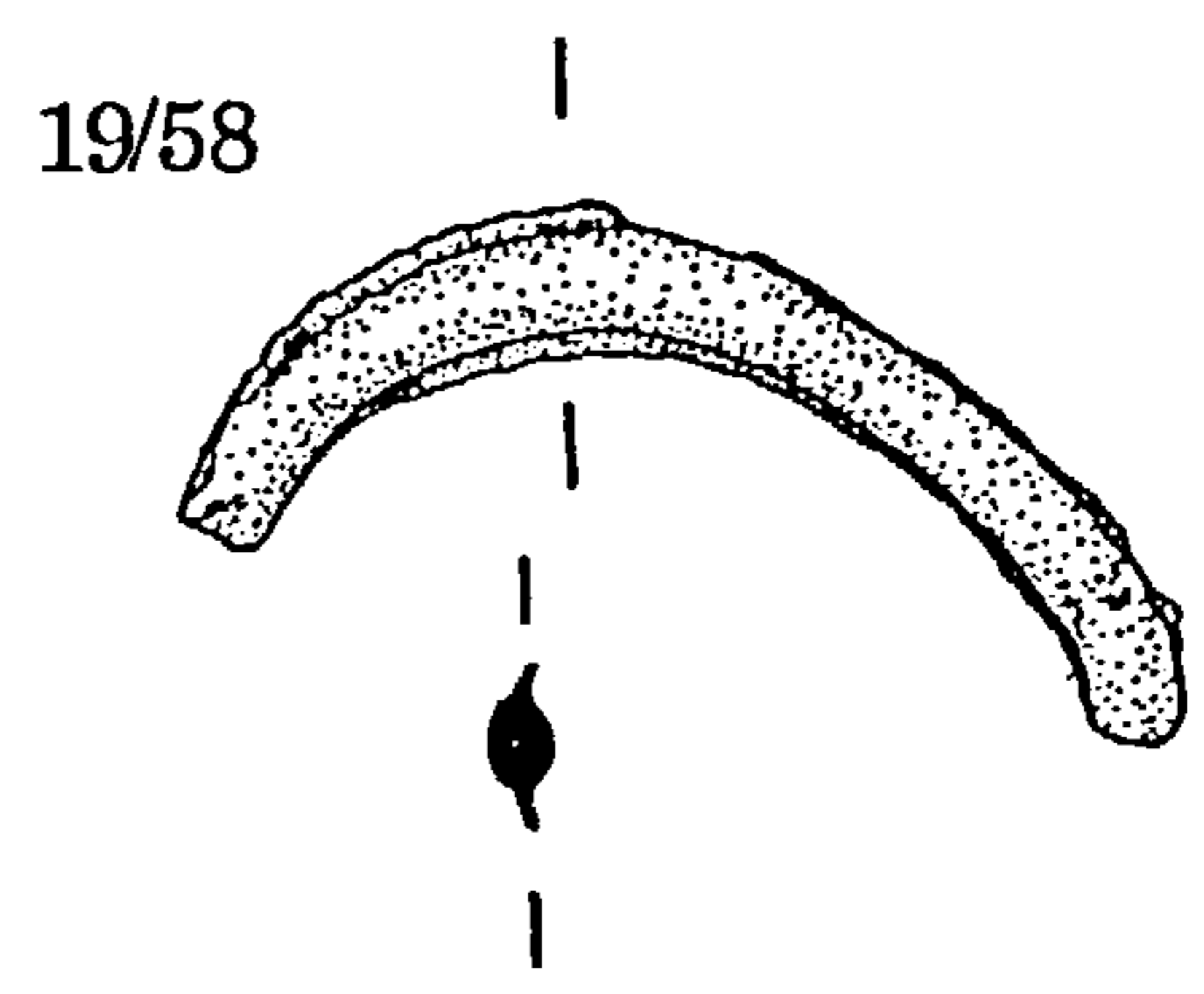
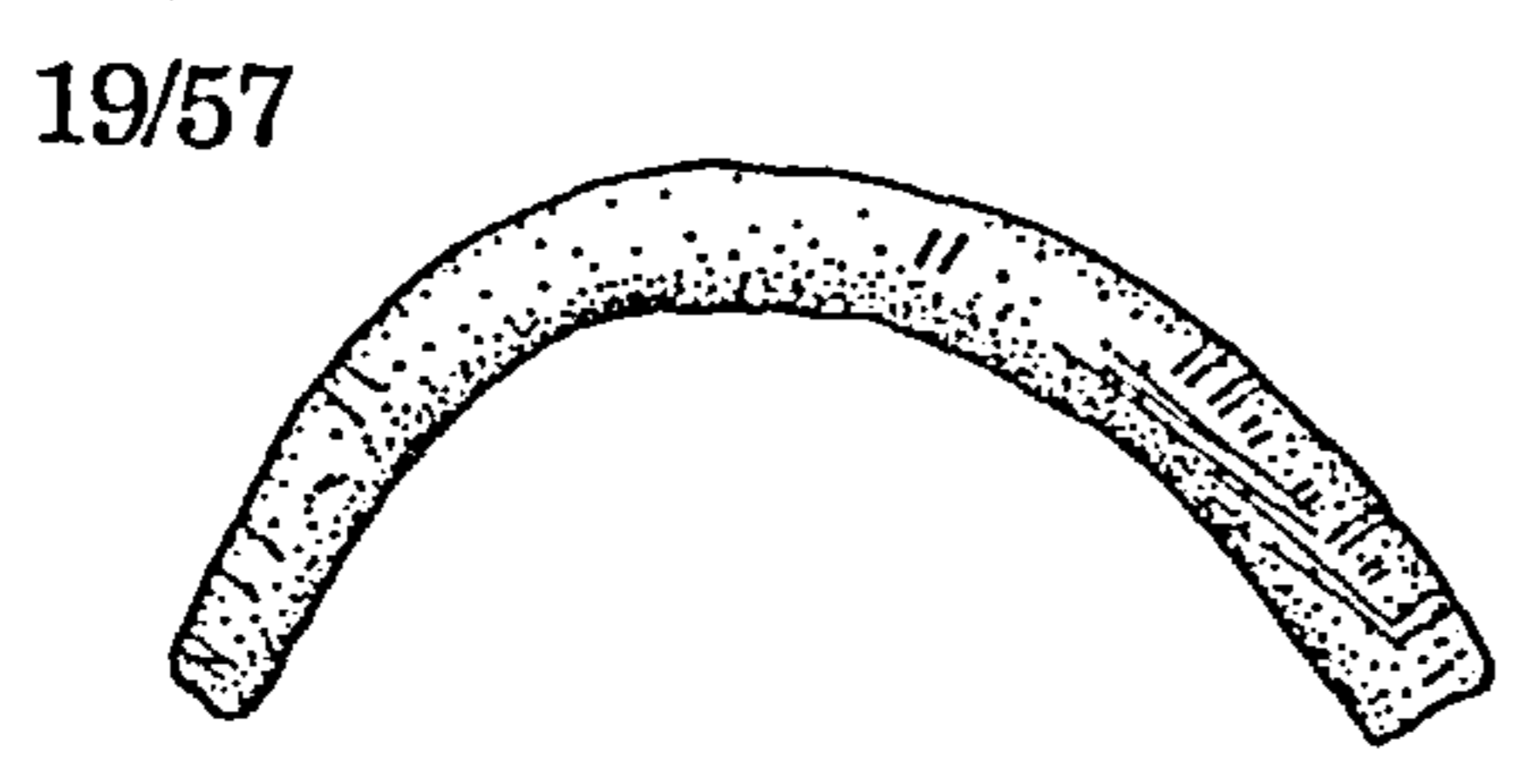
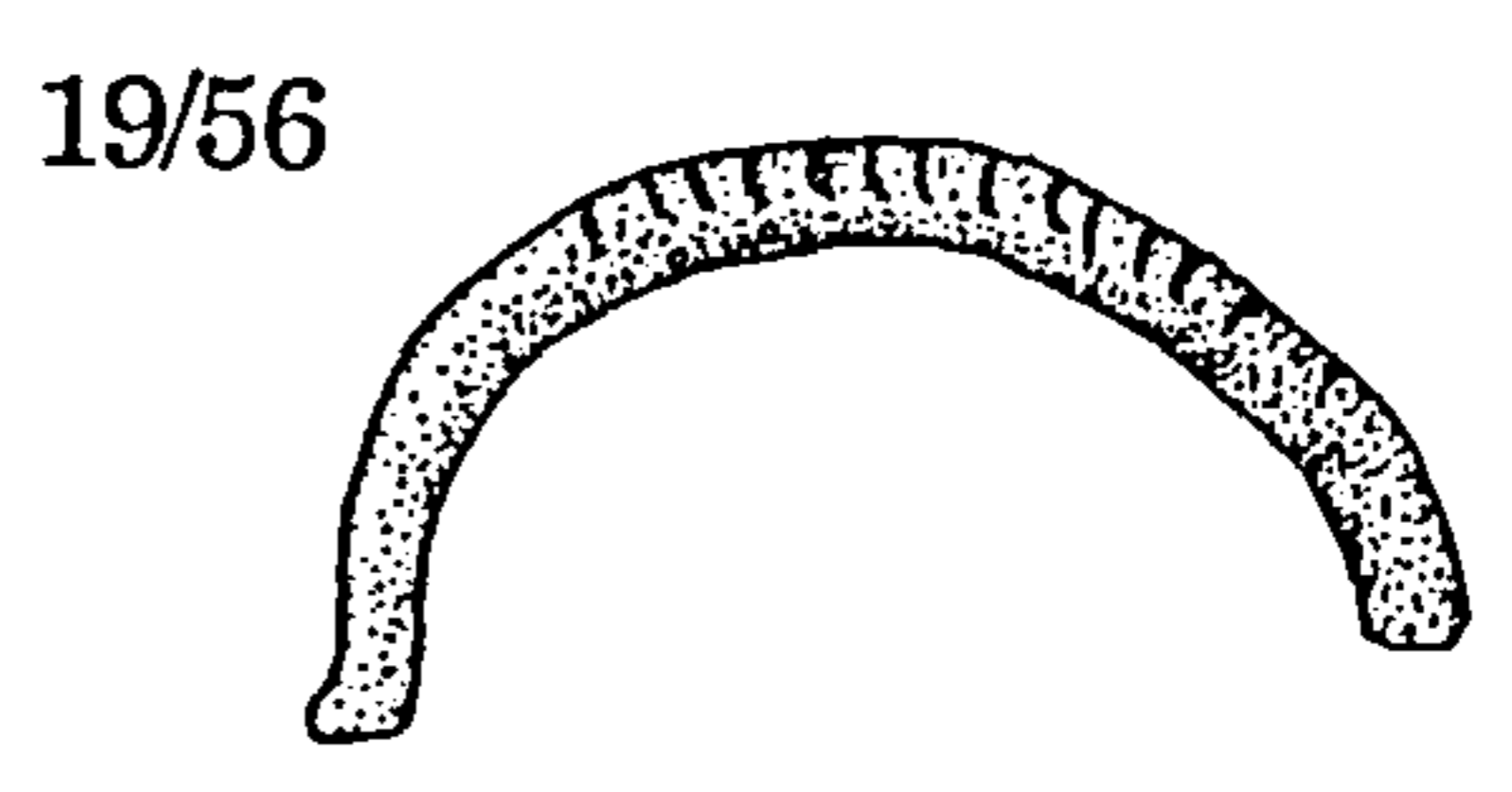
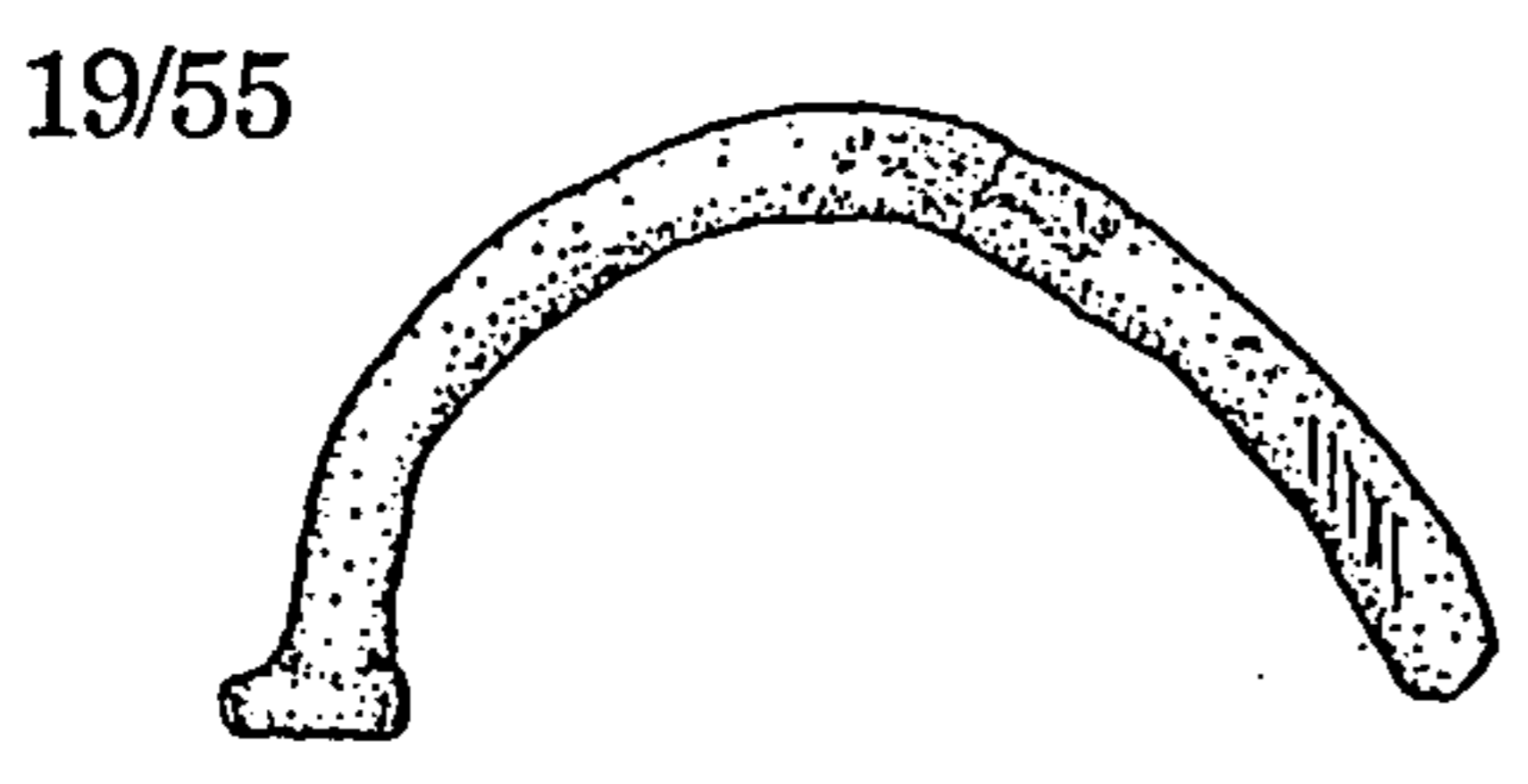
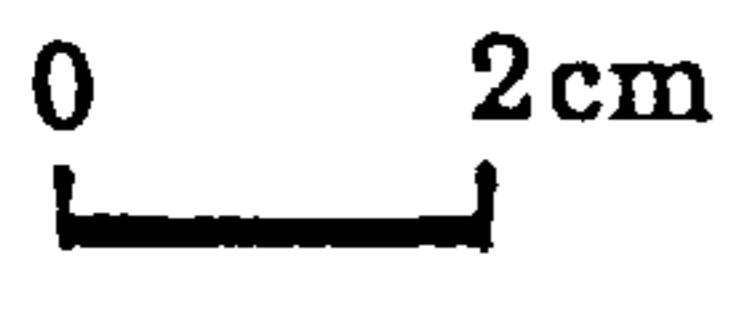
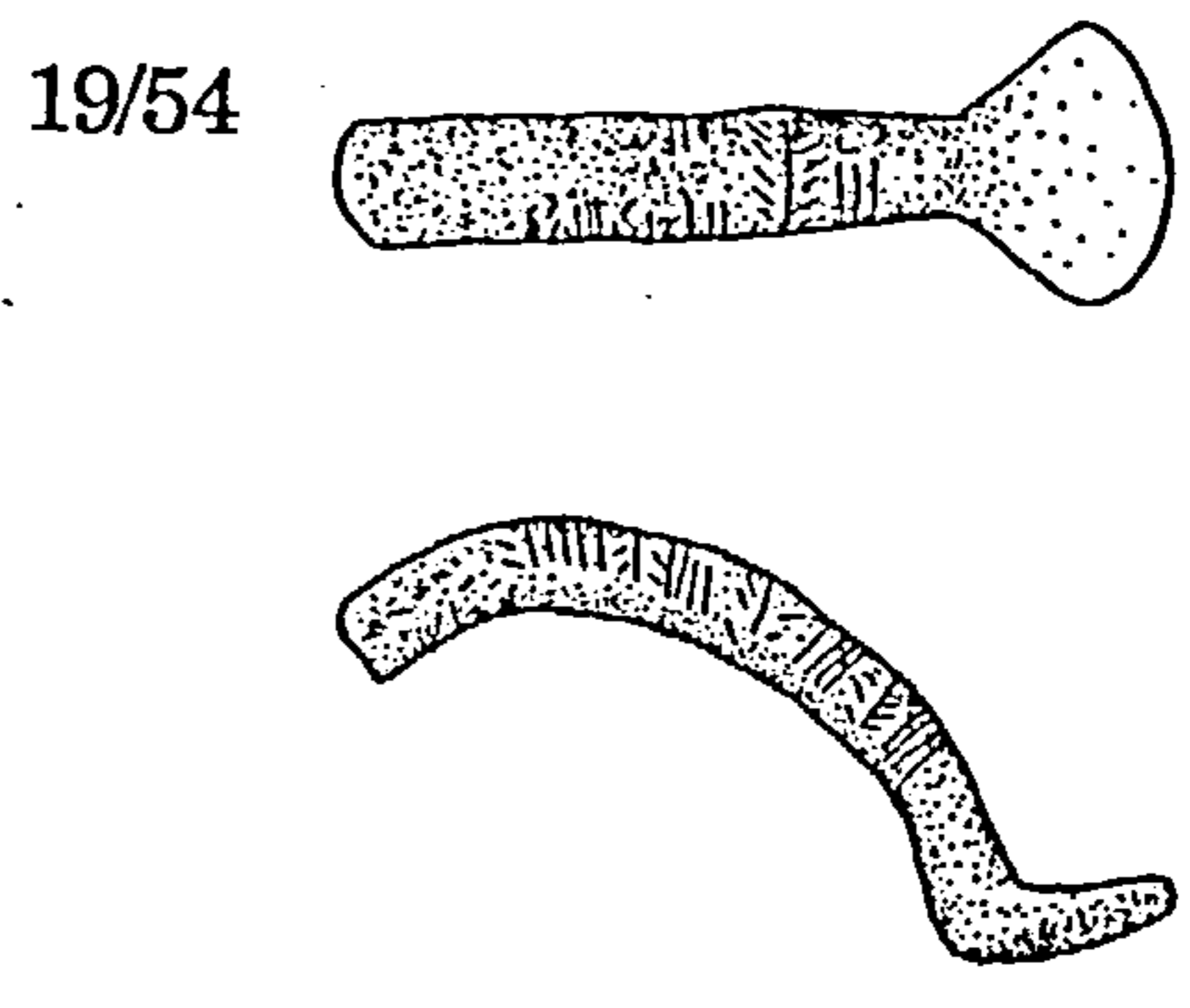
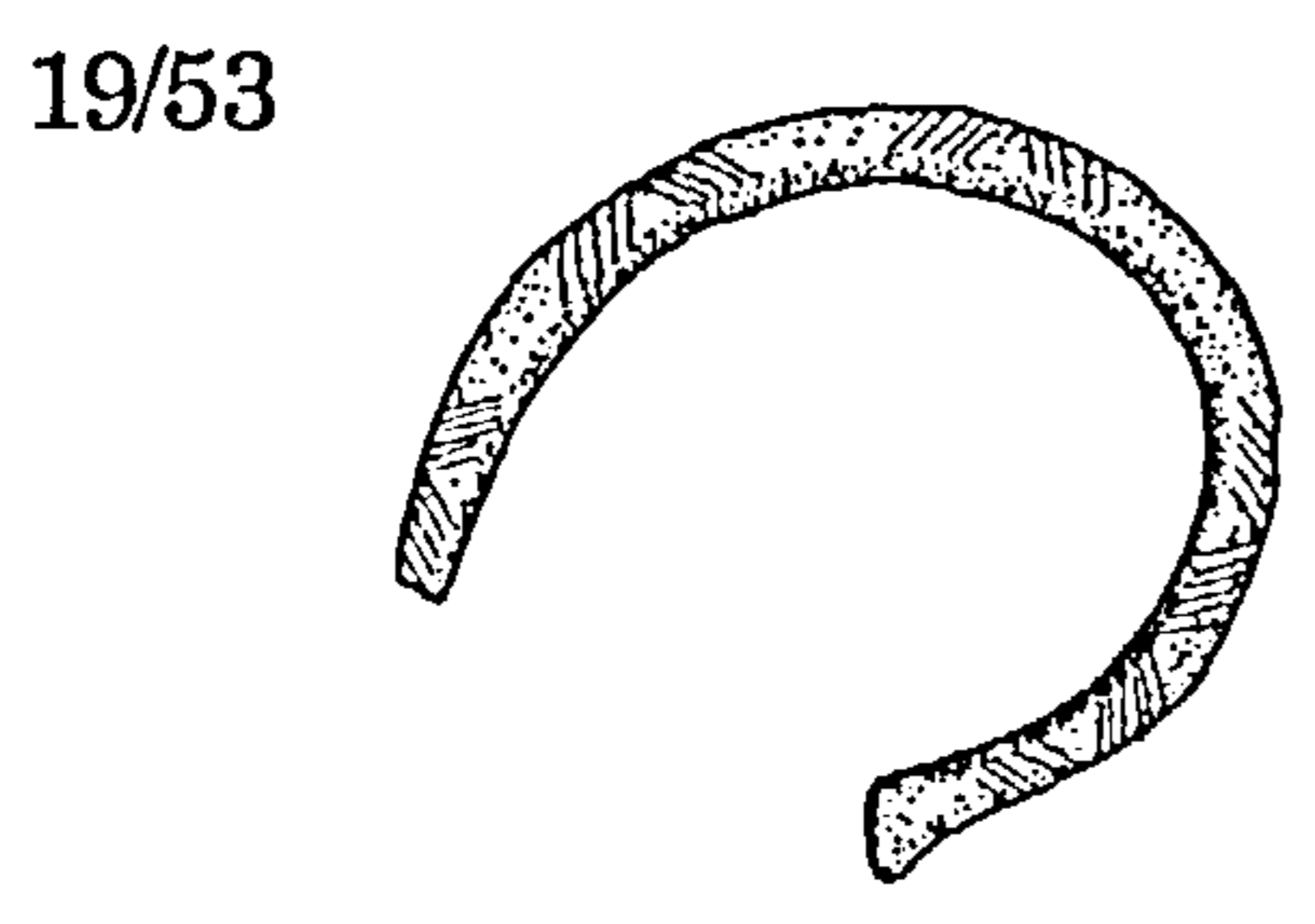
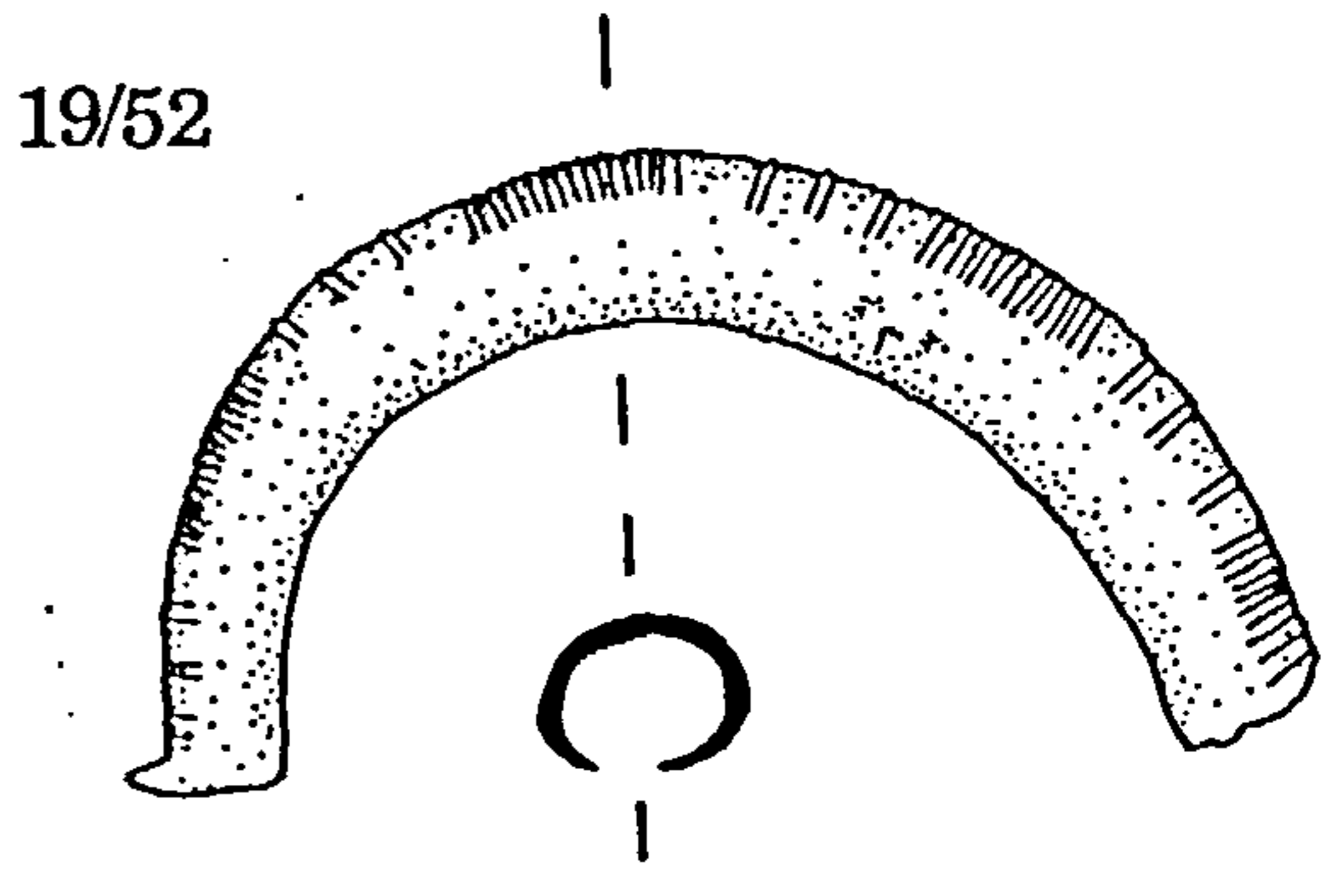
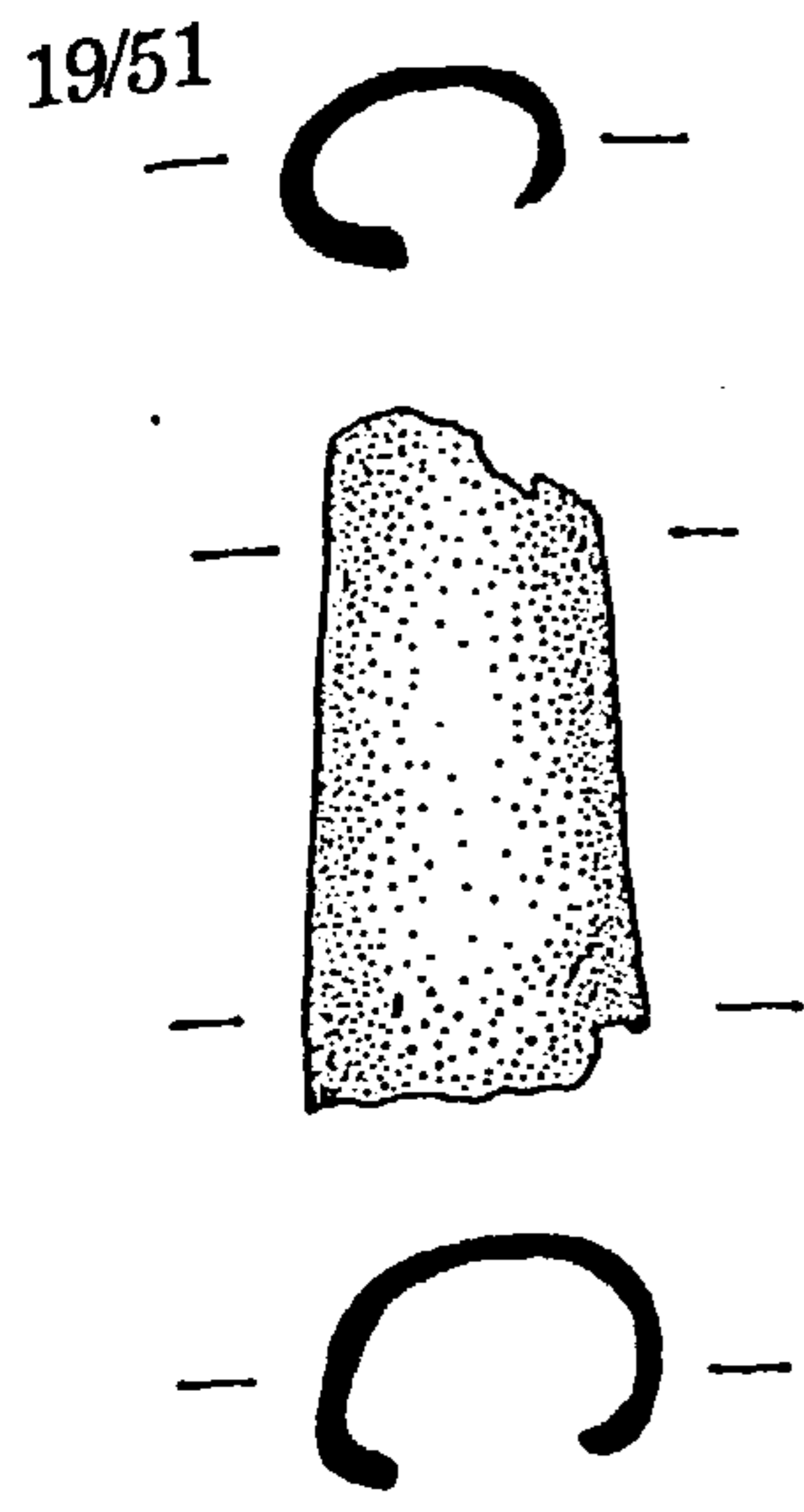


Fig. 49: The Minnis Bay Hoard (Ref. No. 19): Bracelet Fragments

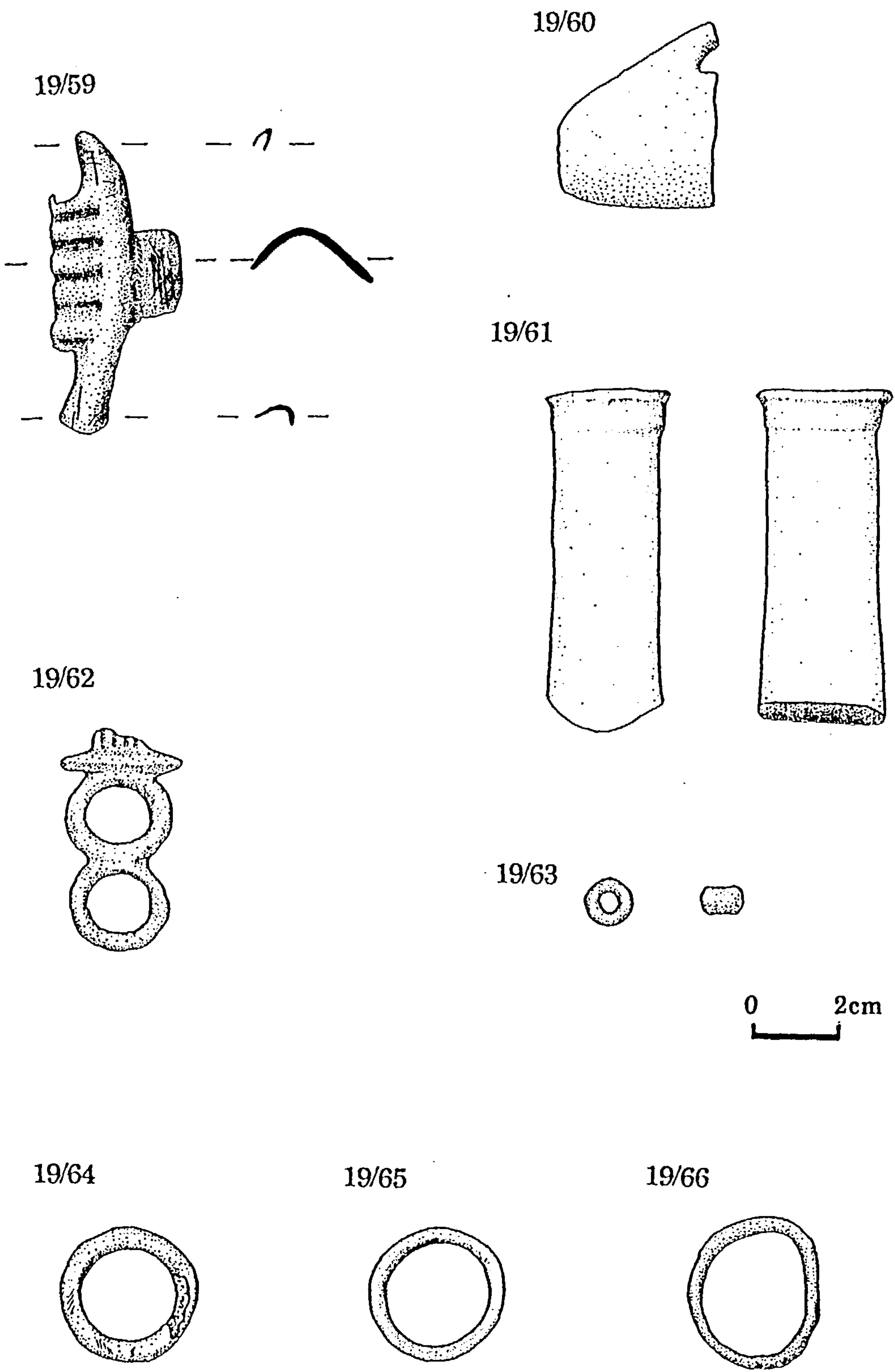


Fig. 50: The Minnis Bay Hoard (Ref. No. 19): Miscellaneous Objects

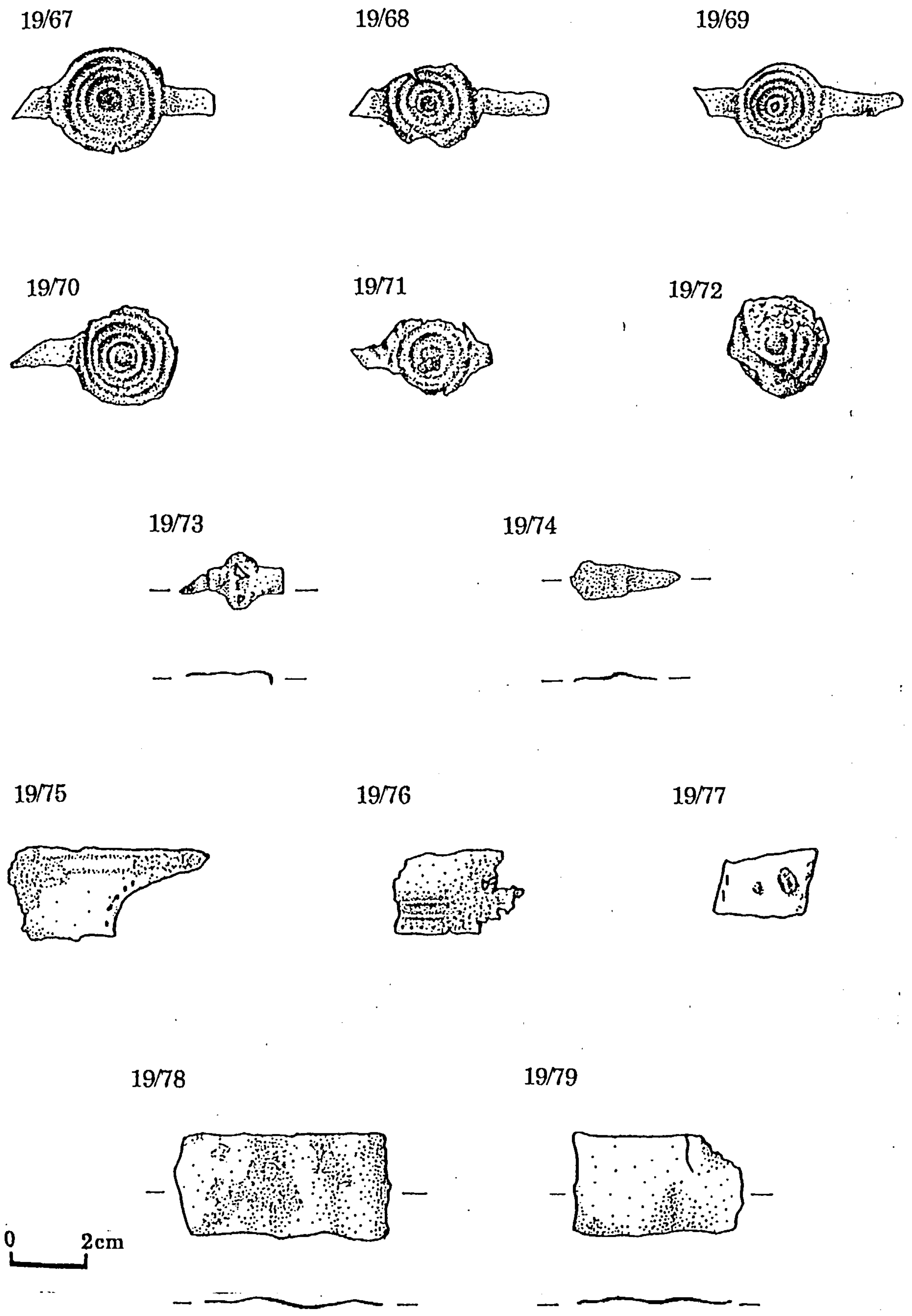


Fig. 51: The Minnis Bay Hoard (Ref. No. 19): Miscellaneous Fragments

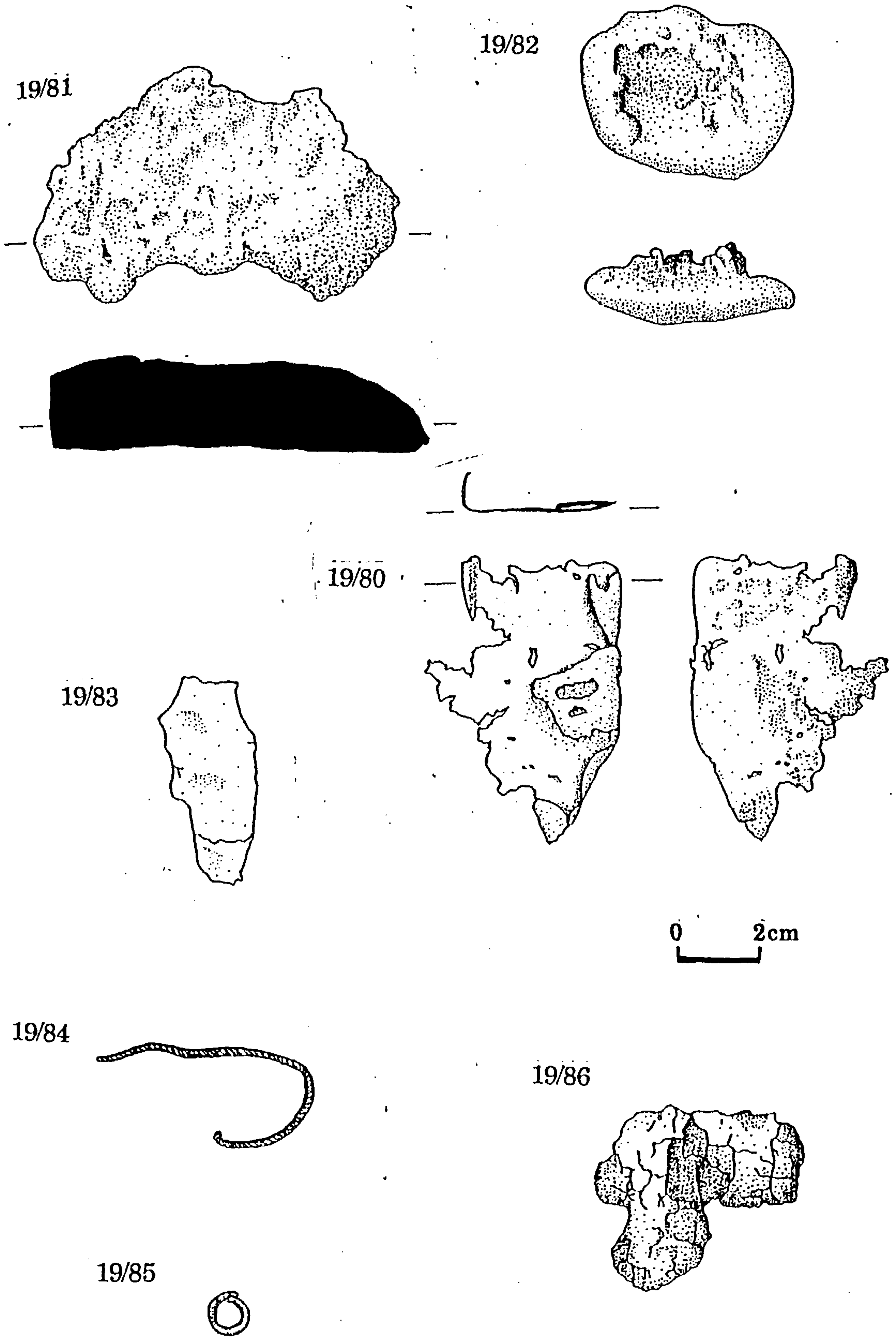


Fig. 52: The Minnis Bay Hoard (Ref. No. 19): Casting Debris, Sheet Bronze and Miscellaneous Items.

Minster (Ref. No. 20)

Grid Reference: TR 33 63.

Current Location: British Museum, Accession Number 93: 4-26.

Context: Found on a farm, no further information available.

Bibliography: Jessup, 1930.
National Bronze Index.
Payne, 1893.

Contents:

20/01 (Acc. No. 93: 4-26: 74)

Description: Socketed axe of faceted type.

Dimensions: Length: 90mm. Cutting edge: 41mm. Weight: 147.8g.

Patina: Rough reddish-brown, with much of the piece now covered with encrustation. The surface appears glossy, possibly as a result of chemical treatment.

Manufacture: The mouth has been well-finished, with no traces of either feeders or casting seams surviving. Over the body, the seams are prominent and remain quite sharp, though they have been obliterated just behind the cutting edge. Diagonal grinding marks are faintly visible at the interface between one face and its adjoining facet, and the cutting edge has been expanded.

Use: The cutting edge appears chipped and notched, but corrosion buildup may have exaggerated any pre-existing damage. The loop is broken, and there is a crack visible in the bronze, running across the lower body. There is no hammering or deformation associated with this, which strongly suggests that this breakage was use-related.

Reduction: The object is complete and there is no evidence relating to this process.

20/02 (Acc. 93: 4-26: 55)

Description: Socketed axe of unknown type, with interior ribs present within the mouth. The mouth has a rather misshapen appearance.

Dimensions: Length: 75mm. Cutting edge: 50mm. Weight: 216.5g.

Patina: Rough brownish-green, details poor.

Manufacture: The collar seems sparse in places, suggesting an inadequate supply of metal during casting. The casting seams are thick and very prominent over the body, showing little signs of having been trimmed or hammered, and they remain prominent over the loop. No traces of the seams survive around the mouth, though this may be because the molten metal never reached the top of the mould and the feeders. The cutting edge is crescentic.

Use: The blade edge appears to have been resharpened, and is unevenly worn. Some of the cutting edge survives, but most appears burred over its length. A long crack runs from the mouth to a point two-thirds of the way down the body, and this damage is likely to be use-related, as no hammer indents or distortion occur in association.

Reduction: The object is complete and there is no evidence relating to this process.

20/03 (Acc. No. 93: 4-26: 73)

Description: Socketed axe, of unknown type, with an unusual collar arrangement that comprises a single elongated moulding.

Dimensions: Length: 82mm. Cutting edge: 49mm. Weight: 103.3g.

Patina: Very rough, with much encrustation apparent. Details much obscured.

Manufacture: There are some very coarse vertical striations visible running down one face, and the blade is well-expanded.

Use: None of the original cutting edge survives, the blade being chipped, notched and burred over its length. The details are slightly unclear as a result of corrosion build-up.

Reduction: One small tool mark, visible just above the cutting edge, may be related with this stage of the object's life-cycle, but this cannot be established with any certainty.

20/04 (Acc. No. 93: 4-26: 61)

Description: Socketed axe, with five ribs apparent on either face.

Dimensions: Length: 104mm. Cutting edge: 58mm. Weight: 357.5g.

Patina: Some olive-green patches remain, but the piece is mainly a rough greenish-brown. Details are reasonable.

Manufacture: The casting seam remains visible around the mouth, and the stump of a feeder survives. On the body, the upper seam is visible right down to the cutting edge, and it seems quite rough in places, though this may be due in part to the nature of the corrosion products. The lower seam has been largely removed, only remaining visible and prominent between the collar and the loop. Horizontal grinding marks can be identified above the cutting edge, and vertical grinding marks are apparent running down between the ribs. The cutting edge is crescentic in appearance.

Use: The cutting edge is unevenly worn, and appears chipped and rough in places. There are some isolated coarse striations visible in places upon the piece.

Reduction: The piece has been crushed. This damage is concentrated in two places: at a point halfway up the body, and in the area of the lower collar moulding. This has caused extensive distortion of the section, and at the mouth the metal is cracked. Similar damage is apparent on both faces, although it seems less pronounced on the side not illustrated. The piece appears to be covered by numerous hammer indents. Many of these are not particularly coarse in nature and may be linked with manufacture.

20/05 (Acc. No. 93: 4-26: 60)

Description: Socketed axe, of 'southern English' type, with 5 ribs running down either face.

Dimensions: Length: 100mm. Cutting edge: 52mm. Weight: 325.9g.

Patina: Rough dark-green, with some olive/bronze patches and also patches of grey-green encrustation. Details good.

Manufacture: The collar is misshapen, suggesting an inadequate supply of bronze during casting, and the stump of a feeder survives at the mouth. Over the body, the casting seams remain thick and prominent over the entire length of the piece. Rough hammering is evident around the ribs, and also above the cutting edge, which is crescentic in shape. There are horizontal grinding marks above the blade, and tiny vertical grinding marks running perpendicular to the cutting edge.

Use: The cutting edge is badly notched and burred. In one area, the piece appears to have struck a sharp object repeatedly in the same spot, as one area of burring shows a series of individual notches along its extent. Isolated coarse striations run down the piece in a number of places.

Reduction: There are some small tool marks visible around the collar, damage which may be related to the removal of the haft. The unusual burring visible on the cutting edge may have been deliberately inflicted as part of this process, i.e. through striking the axehead with a sharp object such as another axehead.

20/06 (Acc. No. 93: 4-26: 63)

Description: Socketed axe, of 'southern English' type, with nine ribs on one face, and ten on the other.

Dimensions: Length: 104mm. Cutting edge: 59mm. Weight: 293.2g.

Patina: Rough grey-green, with some better patches of shiny olive near the cutting edge. Details, where visible, are good.

Manufacture: The mould valves have been slightly mismatched, and there is a stepped appearance to the section as a result of this. The casting seam has been virtually obliterated around the mouth. Elsewhere, on the body, the casting seams remain visible to a point roughly halfway down the length of the piece. Below this, they have been virtually obliterated, and no traces remain over the loop.

Use: The cutting edge seems good in places, but there are localised areas of burring, and in one corner the edge appears to have broken away. Two deep grooves which run across the piece show fresh copper and are obviously the result of later damage.

Reduction: Though the hammering around the mouth has been finely executed, it appears to have damaged the decoration. It might therefore be argued that it is more likely to have been inflicted at this stage, perhaps during the removal of the haft.

20/07 (Acc. No. 93: 4-26: 59)

Description: Socketed axe, of 'southern English' type, with three ribs faintly visible on either face.

Dimensions: Length: 123mm. Cutting edge: 60mm.

Patina: Some detail remains visible, but patches of encrustation obscure the piece in places.

Manufacture: The mouth appears squint, which suggests a misaligned core, and a slight dip in the level of the mouth also indicates a minor casting defect. The casting seam has been removed entirely around the mouth, but over the body the seams remain prominent. The upper seam has been roughly flattened, and has been obliterated over only the lowermost 15mm towards the cutting edge. The lower seam is even more prominent, and has been very roughly finished. Along the line of the seams, there is a slightly stepped appearance to the piece, which suggests mould misalignment. There are some vertical grinding marks running perpendicular to the cutting edge, which is crescentic in shape.

Use: The cutting edge is notched in places, and shows signs of burring along its length. A few chips reveal fresh metal, which indicates recent damage.

Reduction: The object is complete and there is no evidence relating to this process.

20/08 (Acc. No. 93: 4-26: 62)

Description: Socketed axe, of 'southern English' type, with six ribs on either face. Four run down the face, while the other two define the interfaces between the faces and the upper and lower surfaces. One internal rib is visible.

Dimensions: Length: 110mm. Cutting edge: 53mm. Weight: 304.6g.

Patina: Rough olive, with some smoother patches.

Manufacture: The feeders have been roughly removed from the mouth, and the intervening seam remains prominent here. The upper casting seam has been trimmed and hammered over the body, but remains visible, and has only been obliterated just behind the cutting edge. The lower seam is similar, and remains prominent over the loop. Some vertical grinding marks can be seen running down between the ribs, and the blade has been widely expanded.

Use: The cutting edge is chipped and blunted along its length, but its poor condition may have resulted at least in part from the build-up and subsequent flaking of corrosion products.

Reduction: There are small tool marks visible on the piece, especially at the junction between the upper surface and its adjacent face. These may be linked with the removal of the haft.

20/09 (Acc. No. 93: 4-26: 58)

Description: Incomplete socketed axe, of 'southern English' type. Its mouth is now broken but it originally had 4 ribs on either face.

Dimensions: Length (maximum): 80mm. Cutting edge: 48mm. Weight: 170.1g.

Patina: Some bronze-coloured patches remain, but much is now obscured by patches of grey-green encrustation. Details seem reasonable.

Manufacture: The uppermost casting seam has been virtually obliterated, while the lower remains fairly sharp and prominent, though it has been better finished towards the cutting edge. Some vertical striations run down the blade, and there are horizontal grinding marks visible over the cutting edge, which is crescentic in appearance.

Use: The edge has one notch along its length, and a few smaller chips are evident, too. However, it still seems sharp and fine, and may still have been usable.

Reduction: Both faces show slight distortion near the break, though this is barely discernible and must be treated with caution. One or two tenuous hammer marks are also visible here. The most notable damage is upon the face illustrated, where a substantial indentation is apparent, associated with numerous hammer marks.

20/10 (Acc. No. 93: 4-26: 57)

Description: Socketed axe, of 'southern English' type, with three ribs just visible on one face, and the other totally obscured.

Dimensions: Length: 84mm. Cutting edge: 34mm. Weight: 172.2g.

Patina: In very poor condition. A very rough grey-green patina is evident, and most areas are completely covered with encrustation.

Manufacture: Vestigial traces of the feeders remain visible at the mouth, and the seams remain prominent on both sides over most of their extent, including over the length of the loop, though they appear to have been obliterated close to the cutting edge. The blade does not seem well-expanded.

Use: It might have been suggested that the piece was never used, had a large piece not been missing from the cutting edge. This latter damage must, however, be use-related.

Reduction: Hammering is visible in association with the break.

20/11 (Acc. No. 93: 4-26: 64)

Description: Socketed axe of 'south-eastern' type. Both faces are decorated with a central pellet that is flanked on either side by two short parallel ribs. Internal ribs are present.

Dimensions: Length: 100mm. Cutting edge: 46mm. Weight: 219.3g.

Patina: One face is largely covered by a dense olive layer of patina, and the details remain good here. On the other, which is a rougher green/brown colour, details are poor.

Manufacture: Vestigial traces of the feeders remain visible at the mouth, though the intervening seam between these has been removed. Over the body, the casting seams remain prominent on both sides, though they are obscured by corrosion products towards the cutting edge. The seam has been obliterated over the loop. Some vertical grinding marks can be seen in the vicinity of the decoration, and occasional diagonal grinding marks are visible over the lower body. Traces of fine hammering can be seen on the cutting edge, which is crescentic in shape.

Use: The cutting edge is battered and chipped along its length. A crack in the metal which runs from the mouth to the loop is not associated with any hammering or crushing, and this strongly suggests that it results from use-related damage.

Reduction: Small tool marks in the vicinity of the collar are probably linked with the removal of the axehead from the haft.

20/12 (Acc. No. 93: 4-26: 65)

Description: Socketed axe, of 'south-eastern' type. On one face, an unusual wing decorated variant is apparent. One 'wing' comprises an arc-shaped rib with adjacent furrow, while the other is composed of two parallel ribs. The central area is obscured by patina, but no additional ribs, pellets, etc. appear to be present. The other side is ribbed, with six unusually short ribs present. Five are on the face, while one defines the interface between the face and the upper surface. The ribs measure c. 25mm in length, and are of unequal width, with the central example being markedly wider than the rest (fig. 7).

Dimensions: Length: 105mm. Cutting edge: 49mm.

Patina: Some smooth dark-green patches are present, but the blade and most of the body is obscured and in places completely hidden by rough, grey-green encrustation.

Manufacture: The mouth appears well-finished, with no indications of the feeders or the intervening seam surviving. On the body, the upper seam is visible over the collar, but elsewhere it has been obscured by corrosion product. The lower seam is visible over the upper portion of the piece. Below this point it appears to have been removed, though the corrosion product obscures much of the detail. The cutting edge is crescentic.

Use: The edge is unevenly worn, with large pieces missing from its length.

Reduction: The collar appears rough, with small tool marks visible in a number of places, and this damage is likely to have occurred during the removal of the haft.

20/13 (Acc. 93: 4-26: 66)

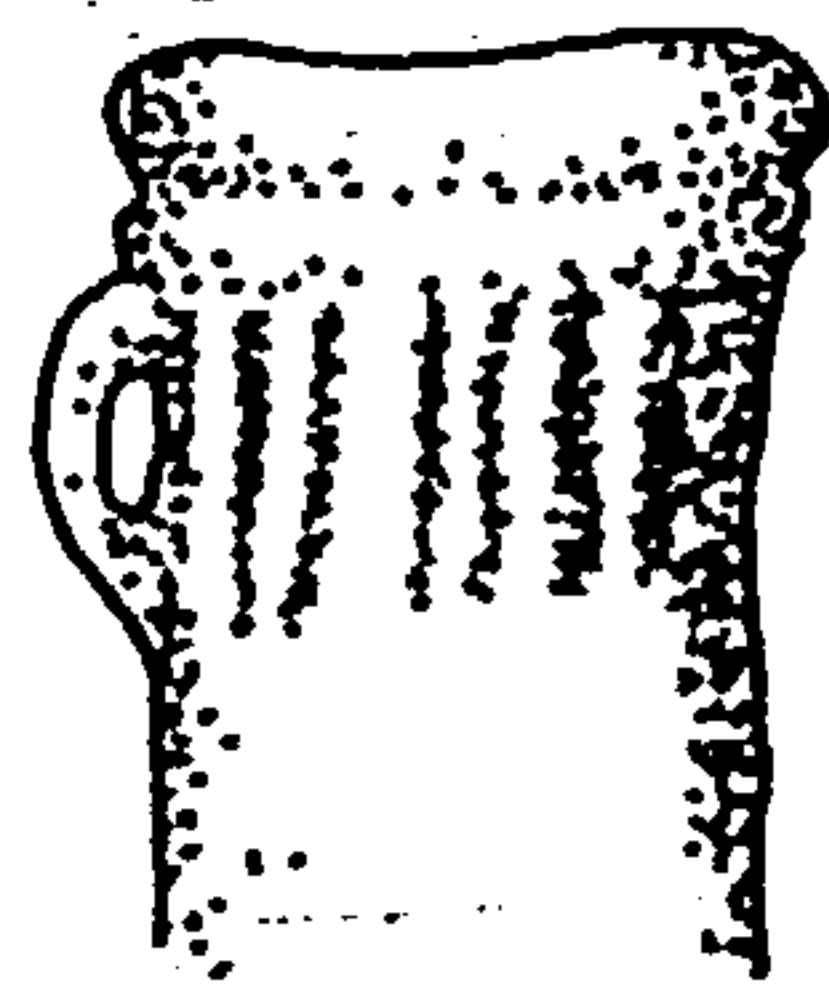
Description: Socketed axe of 'south-eastern' type, the faces decorated with a variant on the wing/pellet decorated form. This consists of two horizontal pellets, associated with indentations which run from the pellets to a point halfway down the body. This example is unusual in that it bears only one collar moulding.

Dimensions: Length: 99mm. Cutting edge: 48mm.

Patina: Some patches of bronze show, but the piece is mostly covered with a thick layer of grey-green encrustation. Details obscured.

Manufacture: One wall seems thin, where the section is revealed by the crack. The mouth is well-finished, with feeders and intervening seam removed. Over the body, both casting

Fig. 7



seams have been flattened, with hammer indents apparent in places, and they appear to have been obliterated near the cutting edge. It is difficult to assess the situation over the loop on account of the corrosion build-up. Grinding marks can be seen in association with the indentations, and the cutting edge is crescentic in appearance.

Use: The edge is chipped over its length, but this may result from the later loss of corrosion products. It seems otherwise intact, and may have been in good condition at the time of abandonment. The crack in the piece is likely to be use-related as no hammer indents or crushing can be seen in association.

Reduction: A piece of rough metal now adheres to the blade, but this is likely to be a post-depositional association, having occurred as a result of corrosion products holding the two pieces together.

20/14 (Acc. No. 93: 4-26: 67)

Description: Socketed axe of 'south-eastern' type, with wing-and-pellet decoration occurring on both faces. Two internal ribs are present.

Dimensions: Length: 117mm. Cutting edge: 49mm. Weight: 289.6g.

Patina: Some patches of smooth patination remain, but most has flaked away, and is now replaced by a rough pale-green/brown surface interspersed with patches of encrustation.

Manufacture: The bronze is pitted in places, and this, along with a number of dips occurring around the mouth, suggests that the casting is of a poor quality. The casting seams have been removed around the mouth, but over the body they remain prominent to a point halfway down the blade. Below this point, they have been obliterated. The seam remains prominent over the loop. Very fine grinding marks are visible over the decorated area, and the blade is well-expanded.

Use: The cutting edge is broken and badly notched in places. Where it remains intact it appears very blunt, though this may be exaggerated by the nature of the corrosion product.

Reduction: Some notches around the collar may have resulted from the removal of the haft.

20/15 (Acc. No. 93: 4-26: 68)

Description: Socketed axe, of 'south-eastern' type, with wing-decoration flanking a central pellet.

Dimensions: Length: 107mm. Cutting edge: 44mm. Weight: 290.0g.

Patina: Rough grey-green, some details visible in places.

Manufacture: The seams remain prominent around the mouth and over the upper body. On both sides of the body, the seams have been removed over the lowermost third of the piece towards the cutting edge. Traces of the seam remain visible over the loop.

Use: The blade appears rough, the cutting edge being chipped at both corners. This damage has probably been exaggerated through the flaking away of corrosion products in recent times, as fresh metal is revealed in places.

Reduction: Slight indentations on the collar may have resulted from the loosening of a tightly wedged haft.

20/16 (Acc. No. 93: 4-26: 69)

Description: Socketed axe, of 'south-eastern' type, with wing-decoration flanking a central pellet on either face.

Dimensions: Length: 95mm. Cutting edge: 53mm. Weight: 233.7g.

Patina: Rough pale-green, with a great deal of encrustation present, though some smooth dense patches remain in places.

Manufacture: The casting seam has been completely removed around the mouth. Over the body, the upper seam is prominent closer to the mouth, but elsewhere details are difficult to determine because of the encrustation. The lower seam appears to have been largely removed, but vestigial traces still remain on the loop and near the mouth. There are some vertical grinding marks visible on the underside, and some striations can be identified in the vicinity of the decoration. Some of this damage appears to be associated with fresh metal, and thus may result from modern damage, but at least some of these marks appear to have originated in antiquity. The cutting edge is crescentic in shape.

Use: The cutting edge has probably been resharpened, and now appears blunt and slightly chipped along its length. Its poor condition may, however, result at least in part from the build-up and loss of corrosion product in more recent times.

Reduction: The object is complete and there is no evidence relating to this process.

20/17 (Acc. No. 93: 4-26: 72)

Description: Socketed axe, of 'south-eastern' type, with a single pellet visible on one face. The other face appears to be undecorated, though corrosion obscures much of the upper body here.

Dimensions: Length: 84mm. Cutting edge: 42mm.

Patina: Much of the piece is covered by a smooth olive-green patina, though some rougher patches of encrustation are apparent. Details are locally excellent.

Manufacture: The seams have been completely removed around the mouth, and also from the loop. Elsewhere, over the body, they remain prominent and quite sharp. Horizontal grinding marks are visible above the cutting edge, and evidence of fine hammering is apparent here, too. The cutting edge is crescentic in appearance.

Use: The blade has probably been resharpened, and appears unevenly worn. It is now blunt over its length and notched in numerous places. Some isolated striations run across the surface of the object, and these may represent use-related damage.

Reduction: The object is complete and there is no evidence relating to this process.

20/18 (Acc. No. 93: 4-26: 70)

Description: Incomplete socketed axe, of 'south-eastern' type, with a chevron decoration occurring beneath the lower collar moulding in the centre of each face. One side of the mouth and the loop are now missing.

Dimensions: Length: 116mm. Cutting edge: 40mm. Weight: 189.2g.

Patina: Some of the original bronze colour survives on the upper body, but large patches of encrustation obscure the blade.

Manufacture: Where the metal is cracked, the wall seems very thin in section, indicating core misalignment. No traces of the seams can be seen where the mouth survives intact, the object appearing well-finished here. Over the body, the upper seam remains prominent near the mouth, and a chaplet survives intact here. Nearer the cutting edge it has been removed, however. On the underside, the line of the seam is obscured by the corrosion product, but where it can be identified, it remains visible. The blade does not appear particularly well-expanded.

Use: The cracking may be use-related, but this cannot be established with certainty.

Reduction: There are hammer indents occurring near the break, but their relationship to the fragmentation process is unclear. Their presence strongly suggests that the damage apparent on this object was inflicted deliberately, however. In addition there are notches clearly visible on the interface between the top surface and one face (not illustrated). These could have been made by a chisel, or even another axe, and they may be occurred during this stage of the object's life-cycle.

20/19 (Acc. No. 93: 4-26: 44)

Description: Socketed axe, of undecorated 'south-eastern' type.

Dimensions: Length: 111mm. Cutting edge: 53mm. Weight: 337.1g.

Patina: Some smooth olive, but other parts are a rough grey/green. The details are reasonably good.

Manufacture: The feeders and the casting seam have been completely removed from around the mouth. The upper seam appears to have been trimmed and flattened over the body, but it still remains prominent. It has, however been obliterated over the last c.10mm above the cutting edge. The lower seam is visible right to the cutting edge, but has been obliterated over the loop. Horizontal grinding marks and fine hammering are visible on the blade, and the cutting edge is crescentic in appearance.

Use: A large notch is missing from the cutting edge, and this is associated with fresh metal. However, it seems likely that though recent damage has occurred around this notch, the actual serious damage to the axe took place in antiquity, since a number of socketed axeheads bear

similar notched blade. Where the edge remains intact it seems quite sharp, but it is chipped in places along its length.

Reduction: The axehead is complete, and there is no evidence relating to this process.

20/20 (Acc. No. 93: 4-26: 46)

Description: Socketed axe, of undecorated 'south-eastern' type, with two internal ribs present.

Dimensions: Length: 102mm. Cutting edge: 48mm. Weight: 250.1g.

Patina: The surface is completely obscured by a layer of lumpy grey-green corrosion, and the details are, as a result, very difficult to determine.

Manufacture: The seam appears to have been removed around the mouth. Elsewhere, the seams remain prominent over much of the body, though they have been obliterated over the final c.10mm back from the cutting edge. The blade is crescentic in appearance.

Use: The cutting edge is unevenly worn, and appears to have been notched over much of its length, though this is difficult to establish with confidence as a result of the patina. A large crack runs down the piece, and this may indicate use-related damage.

Reduction: The crack mentioned above may have occurred during with this process, perhaps during the removal of the haft. There are no signs of any hammer indents in association, but the corrosion products are likely to conceal much information.

20/21 (Acc. No. 93: 4-26: 45)

Description: Socketed axe, of undecorated 'south-eastern' type.

Dimensions: Length: 99mm. Cutting edge: 53mm. Weight: 276.3g.

Patina: Rough grey-green in appearance, with much encrustation on the surface. The details have been virtually obliterated.

Manufacture: Vestigial traces of the feeders can be identified at the mouth. The casting seams are visible along the upper body on both sides, though no traces survive over the loop. Over the lower body, the patina obscures the details. The cutting edge is crescentic in appearance.

Use: There is a large notch missing from the cutting edge and this is associated with burring. This damage has been exaggerated as a result of recent loss of the corrosion product, with fresh metal evident in places.

Reduction: The object is complete, and there is no evidence relating to this process.

20/22 (Acc. No. 93: 4-26: 51)

Description: Socketed axe, of undecorated 'south-eastern' type.

Dimensions: Length: 82mm. Cutting edge: 40mm. Weight: 136.6g.

Patina: The entire piece is covered with thick encrustation. As a result, there are virtually no details visible.

Manufacture: The feeders remain quite prominent at the mouth, and the casting seams appear pronounced through the corrosion layer, even over the loop. It is possible that the upper seam was removed over the lower third of the piece towards the cutting edge, while on the underside it is likely that it survives all the way down to the cutting edge, which is crescentic in shape.

Use: Impossible to determine on account of the corrosion buildup.

Reduction: The object is complete and there is no evidence relating to this process.

20/23 (Acc. No. 93: 4-26: 52)

Description: Socketed axe, probably of undecorated 'south-eastern' type.

Dimensions: Length: 74mm. Cutting edge: 37mm. Weight: 123.0g.

Patina: Some dense olive patches are present, but the surface is mostly covered with pale green encrustation. Few details can be identified.

Manufacture: Stumps of the feeders remain highly prominent at the mouth, and the finishing here appears to have been minimal. The casting seams have been trimmed but they still seem quite sharp and prominent, and they only appear to have been obliterated directly behind the cutting edge. Over the loop, however, the casting seam has been removed completely. The blade is crescentic in appearance.

Use: The cutting edge is blunt and notched over its length, though its poor condition may appear worse following loss of the corrosion product in recent times.

Reduction: The object is complete and there is no evidence relating to this process.

20/24 (Acc. No. 93: 4-26: 53)

Description: Incomplete socketed axe, probably of 'south-eastern' type, with ribs visible on the interior.

Dimensions: Length: 98mm. Cutting edge: 49mm. Weight: 204.9g.

Patina: Very rough. The piece is covered with a thick layer of grey-green encrustation, and the details are no longer visible.

Manufacture: The wall seems markedly thinner at the break, indicating a misaligned core. The mouth has been well finished, with feeders and seams removed, though it seems rather uneven in appearance. Over the body, the upper seam cannot be identified, while the lower seam remains quite sharp and prominent, though it has been removed over the loop. The cutting edge is crescentic in appearance.

Use: The blade is unevenly worn, but all other details are obscured by the patina.

Reduction: There is no evidence surviving. Any hammer indents associated with the break have been obscured as a result of corrosion buildup.

20/25 (Acc. No. 93: 4-26: 54)

Description: Socketed axe, of undecorated 'south-eastern' type.

Dimensions: Length: 88mm. Cutting edge: 42mm. Weight: 198.4g.

Patina: Rough grey-green, little detail visible.

Manufacture: The mouth appears well-finished. Over the body, the upper seam has been trimmed and flattened to the point of near-obliteration. Grinding marks in this area are probably associated with the removal of the seam. The lower seam has been removed over much of its length, though traces are still visible over the collar. The blade is well-expanded.

Use: The blade is blunt and rather notched along its length, but may have been of further use following resharpening.

Reduction: The object is complete and there is no evidence relating to this process.

20/26 (Acc. No. 93: 4-26: 71)

Description: Socketed axe, of 'south-eastern' type, with a single pellet decoration apparent on one face (not illustrated). There are interior ribs present.

Dimensions: Length: 109mm. Cutting edge: 49mm. Weight: 256.5g.

Patina: Rough brownish-green, with some rougher pale-green patches. Some polished olive patina is visible in places, and the detail is better here.

Manufacture: The casting seam has been largely removed around the mouth, but still remains visible. On both sides of the body, the seams remain sharp, although they appear to have been trimmed so they now lie almost flush with the body. They are no longer visible over the area immediately adjacent to the cutting edge, however. Diagonal grinding marks run down the interface between the upper surface and its adjacent face (not illustrated), and one of the faces is covered in a series of coarse horizontal striations (illustrated). The blade shows indications of fine hammering, with horizontal grinding marks apparent over the cutting edge, and also tiny grinding marks running perpendicular to the cutting edge.

Use: Some of the cutting edge remains sharp, but it is chipped over much of its length and one large notch is now missing from its extent.

Reduction: There are some sharp tool marks visible around the collar, and there are also possible chisel marks on one face close to the loop (side not illustrated). Near this there are blunter marks, perhaps from a trunnion chisel, or perhaps even a punch. All of these marks may have been inflicted during the removal of the haft.

20/27 (Acc. No. 93: 4-26: 56)

Description: Socketed axe, of 'south-eastern' type.

Dimensions: Length: 75mm. Cutting edge: 34mm. Weight: 152.2g.

Patina: Rough grey-green, details completely obscured.

Manufacture: Two small holes, situated in the top surface and in one face (illustrated), respectively, are undoubtedly casting flaws. Vestigial traces of the feeder survive at the mouth, which appears otherwise well-finished. Over the body, the casting seam is still visible on the upper surface, though it has been virtually obliterated here. The lower seam appears similar, but the patina obscures much detail here, though traces remain over the loop.

The blade been expanded slightly, but the object may never have been properly prepared for use.

Use: The blade seems to be intact, and is blunt in appearance. Some chipping is apparent, but this may result from the recent loss of corrosion products.

Reduction: Hammering has caused a marked indentation in one face (illustrated), and this damage was probably inflicted during the separation of axehead and haft.

20/28 (Acc. No. 93: 4-26: 43)

Description: Incomplete socketed axe, probably of undecorated 'south-eastern' type.

Dimensions: Length: 100mm. Cutting edge: 52mm. Weight: 284.8g.

Patina: Mainly a dense olive-green. The detail is excellent, although there are one or two patches of encrustation which obscure a little.

Manufacture: Some vestigial traces of the casting seam remain around the mouth. Over the body, the upper seam remains prominent, and while it appears to have been flattened, no additional trimming or grinding is evident here. The lower seam has been virtually obliterated over the loop, and from beyond this point towards the cutting edge. Vertical grinding marks run down the blade on both faces, and there are also traces of horizontal grinding marks, though these have been obscured by the later superimposition of the vertical examples. Much of the body also has a faintly rippled appearance caused by fine hammer working. A faint bevel runs along the cutting edge, which is somewhat crescentic in appearance.

Use: The cutting edge is very blunt, and shows slight indications of uneven wear.

Reduction: Both faces are covered by small tool marks, inflicted perhaps by a trunnion chisel or lightweight hammer. There is a possible hammer indent visible where the upper surface adjoins one face, and extensive hammering around the area of the mouth has pushed the socket inwards, causing significant distortion. Part of the mouth has broken away, but it is difficult to determine whether this damage resulted from the hammering or whether it took place at an earlier point in time, i.e, as a result of use-related damage.

20/29 (Acc. No. 93: 4-26: 47)

Description: Socketed axe, of undecorated 'south-eastern' type.

Dimensions: Length: 100mm. Cutting edge: 53mm. Weight: 256.7g.

Patina: Mainly polished olive-green, with some patches of dusty brown and also a few areas of grey-green encrustation obscuring detail in places.

Manufacture: A slight dip in the mouth indicates a minor casting flaw. The mouth itself is well-finished, with remnants of the seam just visible here. Over the body, the upper seam has been trimmed and flattened, and it may have been ground down to some extent, though it still stands slightly proud. It has been obliterated from a point c.10mm back from the cutting edge, however. The lower seam has been flattened, though it remains prominent, and has been obliterated over the final 10mm towards the edge, and over the loop, too. The area above the blade has a slightly dimpled appearance, indicating fine hammer-working.

Use: Where the cutting edge survives, it is blunt and burred, and is broken and chipped over much of its length. There are a few isolated striations running vertically down the piece. These seem too coarse and too irregular to be grinding marks, and they appear to have originated in antiquity, so a use-related origin must seem likely.

Reduction: There is a single small tool mark visible on the collar, and this may have originated during the separation of the axehead and the haft.

20/30 (Acc. No. 93: 4-26: 48)

Description: Socketed axe, of undecorated 'south-eastern' type.

Dimensions: Length: 95mm. Cutting edge: 50mm. Weight: 210.4g.

Patina: Dense, but rather rough, olive, with patches of thick, grey-green encrustation obscuring much detail.

Manufacture: There is a substantial casting defect evident at the mouth. It comprises a marked dip at one side, which corresponds with an unusually thin wall, indicating a combination of an inadequate metal supply and a misaligned core. The casting seam has been removed around the mouth, and over the body both seams have been trimmed and flattened, though they remain prominent almost up to the cutting edge. Virtually no traces of the seam remain over the loop, however. The cutting edge is crescentic in appearance.

Use: The blade is unevenly worn, and the cutting edge is chipped and blunted over much of its length. Much of this damage appears to date from antiquity, though the poor condition has been exaggerated by the build-up and subsequent loss of corrosion products.

Reduction: The object is complete and there is no evidence relating to this process.

20/31 (Acc. No. 93: 4-26: 49)

Description: Socketed axe of 'south-eastern' type, with a single rib present in the interior.

Dimensions: Length: 86mm. Cutting edge: 36mm. Weight: 151.6g.

Patina: Rough grey-green.

Manufacture: A large groove can be seen in the area of the loop, and lying below this is an area where the metal is markedly thinner (illustrated). Though this indicates a failure of the molten metal to circulate properly within the mould, it has not been severe enough to have left a gap in the casting. Around the mouth, the stump of a feeder remains quite prominent on one side, while the other, though not so pronounced, is still visible. Over the body, both casting seams have been trimmed and flattened, and have been virtually obliterated over the lowermost third of the piece towards the cutting edge. The seam has been completely removed over the loop, and the cutting edge has been expanded.

Use: Where the cutting edge survives, it appears smooth but blunt, but substantial notches are present and the metal is burred in these areas.

Reduction: A notch in the collar seems too irregular to have resulted from deliberate damage, and may be an additional casting flaw. Some marked grooves on one face (illustrated) have a different patina, and may not date to antiquity. It is therefore difficult to isolate any evidence which belongs to this stage in the object's life-cycle.

20/32 (Acc. No. 93: 4-26: 56)

Description: Incomplete socketed axe, probably of undecorated 'south-eastern' type.

Dimensions: Length: 83mm. Cutting edge: 42mm. Weight: 110.9g.

Patina: Rough grey-green, details obscured.

Manufacture: The wall seems thin where breakage has occurred, indicating core misalignment. The stump of a feeder remains visible at the mouth, with casting seams flattened but prominent over and around the collar mouldings. On the body, the seams have been trimmed and flattened, but they remain clearly visible, though they are obscured by corrosion buildup in places. They have, however, been obliterated on both sides towards the cutting edge from a point c.15mm back.

Use: The edge is chipped and broken over much of its length, but fresh copper shows through in places, suggesting that at least some of this damage may be of more recent date.

Reduction: Much of one face and its adjoining lower surface is now missing, and cracking is evident in the casting near where breakage has occurred. There are possible hammer indents occurring in association with the break, but it is difficult to assess the validity of these marks on account of the corrosion product.

20/33 (Acc. No. 93: 4-26: 80)

Description: Mouth and upper body of 'southern English' type socketed axe, with six short ribs on either face.

Dimensions: Length (maximum): 75mm. Weight: 172.8g.

Patina: Rough grey-green.

Manufacture: One feeder remains as a vestigial trace at the mouth, with no traces of the casting seam surviving here. Over the body, the seam is visible on the upper surface until just below the collar mouldings, having been obliterated beyond a point roughly equivalent with the end of the ribbed decoration. On the lower surface, removal has been less stringent. Here, the seam is very pronounced over the collar mouldings, and though it has been virtually obliterated over the loop, it remains visible until c.10mm back from the break.

Use: Impossible to determine.

Reduction: Marked indentations are associated with the break on either face, and the section shows distortion as a result. Hammering is clearly visible near the break on both faces.

20/34 (Acc. No. 93: 4-26: 82)

Description: Mouth and upper body of wing-decorated 'south-eastern' type socketed axe, with a possible central pellet. Interior ribs are apparent.

Dimensions: Length (maximum): 63mm. Weight: 149.6g.

Patina: Rough grey-green, details obscured.

Manufacture: A dip in the mouth indicates a minor casting flaw. Elsewhere around the mouth, the feeders and the intervening seam have been removed. The condition of the casting seams on the upper and lower surfaces cannot be determined as a result of the patina, though they appear very pronounced over the collar mouldings.

Use: Impossible to determine.

Reduction: No evidence can be securely linked with this process. The section shows no signs of distortion and there are no visible signs of hammering, though the fine detail is probably obscured by the patina.

20/35 (Acc. No. 93: 4-26: 78)

Description: Mouth and upper body of 'south-eastern' type socketed axe.

Dimensions: Length (maximum): 56mm. Weight: 132.7g.

Patina: Dense dark-green.

Manufacture: The mouth is uneven in appearance, indicating an inadequate supply of metal during casting. The feeders have been roughly removed and their vestigial remains hammered down, and around the mouth the casting seam is still visible, though flattened. Over the body, the casting seams have been virtually obliterated, and the piece is largely well-finished, with traces only remaining visible between the loop and the collar, and, unexpectedly, on the interior of the loop.

Use: Impossible to determine.

Reduction: Hammering on one face has almost obliterated the lower collar moulding. The gash in the top moulding associated with this has the appearance of a casting defect, but it may result from damage inflicted at this stage. Though the blade has now been removed, no indications of hammering or distortion can be seen in association with the break. A crack runs back from the break at one point, however (illustrated), and there are some probable chisel marks on the body.

20/36 (Acc. No. 93: 4-26: 75)

Description: Mouth and upper body of 'south-eastern' type socketed axe, probably undecorated, with ribs visible on the interior.

Dimensions: Length (maximum): 80mm. Weight: 165.8g.

Patina: Some smooth bronze-olive patina remains, but most of the piece is thickly encrusted with pale green or brownish-green. Detail is much obscured.

Manufacture: One wall seems rather thin in section, indicating a misaligned core. Vestigial traces of the feeders still remain visible at the mouth, but the intervening seam has been well-finished. The mouth seems uneven, the result of an inadequate metal supply having been used during casting. Over the body, the seams have been trimmed and virtually obliterated, but they remain quite sharp. There are some vertical grinding marks running down the body.

Use: Impossible to determine.

Reduction: A cluster of hammer indents can be seen near the break, and there is a slight but noticeable indentation apparent in the metal here (fig. 8).

20/37 (Acc. No. 93: 4-26: 77)

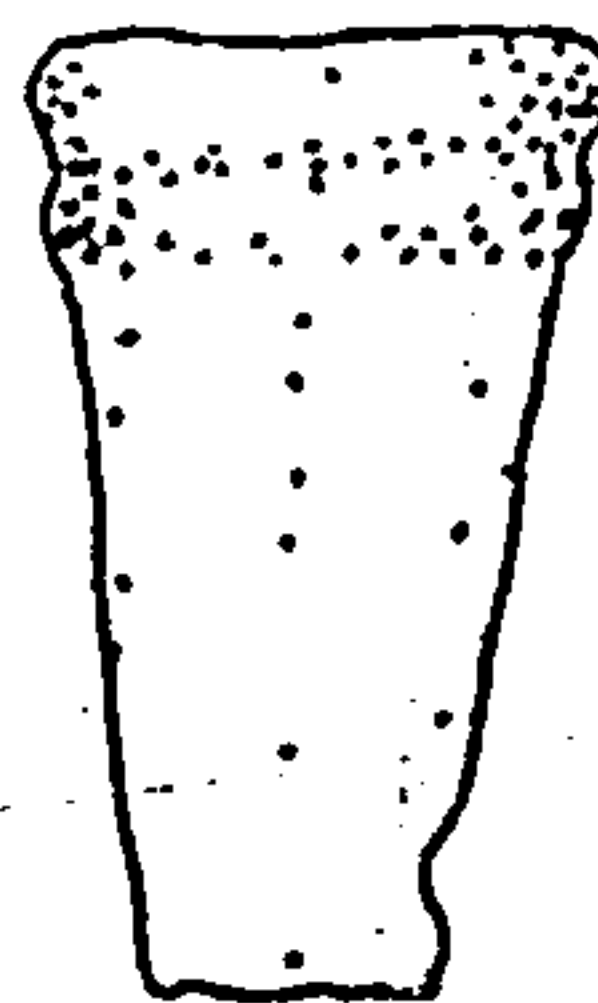
Description: Mouth and upper body of 'south-eastern' type socketed axe.

Dimensions: Length (maximum): 68mm. Weight: 152.8g.

Patina: Rough grey-green.

Manufacture: The mouth appears squint, and the thickness of the wall is uneven, suggesting a combination of core misalignment and perhaps a shortage of molten metal during casting. Around the mouth, the seams and feeders are well-finished, and though they remain visible here, they appear smooth and polished. The situation is similar elsewhere, with the

Fig. 8



seams surviving in vestigial form, though they are once again well-finished. They have been obliterated only in the immediate vicinity of the break and over the loop.

Use: Impossible to determine.

Reduction: There is a marked indentation in one face in the area below the loop. The section is crushed and distorted at the break, and hammering is visible in association with this damage. There is a fragmentary object lodged inside the piece, possibly a mouth fragment from a socketed axe.

20/38 (Acc. No.93: 4-26: 76)

Description: Mouth and upper body of 'south-eastern' type socketed axe.

Dimensions: Length (maximum): 76mm. Weight: 167.9g.

Patina: Much is a shiny, brownish-bronze colour, with patches of rough, dark green encrustation present. The piece may have been chemically treated.

Manufacture: Vestigial traces of the feeders are still visible at the mouth. Over the body, the seams remain prominent and rather sharp, but they have been removed completely from over the loop.

Use: Impossible to determine.

Reduction: Small tool marks and hammer indents can be seen around the mouth. There is a slight indentation in the section near the break, but any hammering associated with this has been obscured by the corrosion product.

20/39 (Acc. No. 93: 4-26: 79)

Description: Mouth and upper body of 'southern English' type socketed axe. There are six ribs on one face and an indeterminate number on the other, and two ribs visible in the interior of the mouth.

Dimensions: Length (maximum): 70mm.

Patina: Grey-green, rough in appearance, with some denser olive patches apparent.

Manufacture: One wall is markedly thinner in section, indicating core misalignment. The casting seams remain prominent in places around the mouth, but no traces of the feeders survive. On the body, the casting seams survive over the collar mouldings, and they remain visible slightly beyond this point on either side, but elsewhere they are obscured by the corrosion product.

Use: Impossible to determine.

Reduction: There are some small tool marks evident around the mouth, and a slight indentation can be seen at the break. No hammer marks can be seen in association with the break, but the corrosion product may obscure much detail here.

20/40 (Acc. No. 93: 4-26: 84)

Description: Long mouth fragment of socketed axe, comprising the upper surface and part of an adjoining face. It probably came from a 'south-eastern' type socketed axe.

Dimensions: Length (maximum): 64mm. Weight: 57.9g.

Patina: Fairly smooth dark-green, details reasonable.

Manufacture: The seams have been removed around the mouth. Where they survive over the body, they have been trimmed and flattened, but they remain visible and are prominent in places. They have been completely obliterated near the lower break.

Use: Impossible to determine.

Reduction: Some hammer indents (not illustrated) are visible on the lower break.

20/41 (Acc. No. 93: 4-26: 83)

Description: Long mouth fragment of socketed axe, with two ribs visible, though the piece would probably have had a total of three upon its face, judging from their spacing. There is a single collar moulding apparent, suggesting that the fragment came a 'foreign' type, such as a Yorkshire type axehead.

Dimensions: Length (maximum): 73mm. Weight: 74.7g.

Patina: Dense dark-green, details good.

Manufacture: A stump of a feeder survives at the mouth, and a length of seam remains obtrusive here, though it has been trimmed and flattened. Where the body survives, the seam still remains visible. It has been trimmed, and bears numerous notches across its length which appear to be chisel marks, inflicted during the removal of the seam. Hammering and

grinding has not occurred here, and in this respect this piece does not appear particularly well-finished in comparison with other examples.

Use: Impossible to determine.

Reduction: The entire piece has been hammered, with one rib appearing distorted as a result of this. There are a cluster of chisel-marks on the face at one point (illustrated), and several hammer indents can be identified at the break. The section is much distorted.

20/42 (Acc. No. 93: 4-26: 86)

Description: Mouth fragment of socketed axe, comprising part of the upper surface only. A double collar moulding is apparent, which suggests that this fragment came from a 'south-eastern' type axe.

Dimensions: Length (maximum): 42mm. Weight: 33.6g.

Patina: Dull grey-green, details reasonable.

Manufacture: Vestigial traces of the casting seam remain visible around the mouth, though it appears to have been trimmed and flattened here. A casting seam also runs down the surviving length of the fragment, and this remains quite prominent, though it has been hammered flat below the level of the collar mouldings.

Use: Impossible to determine.

Reduction: Hammer indents are associated with the break on one side of the fragment.

20/43 (Acc. No. 93: 4-26: 85)

Description: Mouth fragment of socketed axe, probably of 'south-eastern' type. One collar moulding is clearly visible around the mouth, with a second moulding surviving in places.

Dimensions: Length (maximum): 50mm. Weight: 21.7g.

Patina: Rough grey-green.

Manufacture: The wall is thin on one side, indicating core misalignment. The casting seams have been completely removed around the mouth, and no other evidence can be linked with this process.

Use: Impossible to determine.

Reduction: There are possible hammer indents apparent near the break in several places.

20/44 (Acc. No. 93: 4-26: 87)

Description: Mouth fragment of socketed axe, with four collar mouldings present, the uppermost being larger and more prominent. The fragment shows rib- or possibly wing-decoration, and is probably of 'south-eastern' type.

Dimensions: Length (maximum): 40mm. Weight: 37.4g.

Patina: Dense olive, with some patches of encrustation. Details reasonable.

Manufacture: The mouth seems rather uneven in appearance, and this indicates that an inadequate supply of metal was used in casting. The casting seams are still visible around the mouth and over the body, though they appear to have been trimmed and flattened.

Use: Impossible to determine.

Reduction: There is no evidence relating to this process.

20/45 (93: 4-26: 88)

Description: Mouth fragment of socketed axe, including loop.

Dimensions: Length (maximum): 43mm. Weight: 30.2g.

Patina: Rough grey-green, details obscured.

Manufacture: The casting seams remain thick and prominent over the extent of the piece, including the loop.

Use: Impossible to determine.

Reduction: Hammer indents are visible on the collar. There is also a small fragment of bronze jammed into the loop, effectively blocking it. It is curved, and may be part of a socket, i.e. a fragmentary socketed spearhead, but its section seems unusually thin.

20/46 (Acc. No. 93: 4-26: 92)

Description: Mouth fragment of socketed axe, probably of 'south-eastern' type.

Dimensions: Length (maximum): 20mm. Weight: 10.8g.

Patina: Glossy olive, and smooth.

Manufacture: The seams around the mouth have been completely removed, and there is no other evidence relating to this process.

Use: Impossible to determine, though a deep, isolated striation which runs down the piece was apparently caused in antiquity.

Reduction: Hammering can be seen in association with the break, and there are also some small tool marks and hammer indents visible around the mouth.

20/47 (Acc. No. 93: 4-26: 89)

Description: Mouth fragment of 'south-eastern' type socketed axe, including loop.

Dimensions: Length (maximum): 31mm. Weight: 24.7g.

Patina: Rough grey-green, details reasonable.

Manufacture: A notch missing from the loop has a rounded appearance and is probably a minor casting defect. The casting seam around the mouth remains visible, though it has been trimmed and hammered flat. The situation is similar where the seam survives on the lower surface, though all traces have been obliterated over the loop.

Use: Impossible to determine.

Reduction: A chisel mark on the loop may have been inflicted during the cutting of the material which bound the axehead to the haft.

20/48 (Acc. No. 93: 4-26: 90)

Description: Mouth fragment of socketed axe.

Dimensions: Length (maximum): 24mm. Weight: 36.0g.

Patina: Very rough grey-green, details obliterated.

Manufacture: No traces of any casting seams survive around the mouth, and there is no additional evidence pertaining to this process.

Use: Impossible to determine.

Reduction: The section is distorted and crushed, but there are no signs of any hammering in association. This is probably because the corrosion product conceals the surface.

20/49 (93: 4-26: 91)

Description: Fragment of socketed axe. A slight rib runs down the piece - this is some form of decoration, but its exact form is unknown. The axehead may once have had two collar mouldings, and may be of 'south-eastern' type.

Dimensions: Length (maximum): 32mm. Weight: 18.4g.

Patina: Fairly smooth dark-green.

Manufacture: The seams around the mouth have been removed, and a slight dip in the mouth may indicate a minor casting defect. There is no additional evidence pertaining to this process.

Use: Impossible to determine.

Reduction: No hammer indents can be seen in association with the break. A piece of rough metal now adheres to the piece.

20/50 (93: 4-26: 95)

Description: Blade fragment of socketed axe.

Dimensions: Length (maximum): 54mm. Cutting edge: 54mm. Weight: 151.9g.

Patina: Dense olive with some rough patches.

Manufacture: The casting seams remain visible and relatively prominent over the lower body, on one side surviving right up to the cutting edge. There are diagonal grinding marks visible in places, and horizontal grinding marks over the cutting edge.

Use: The cutting edge is notched and burred over much of its length, with only about a third of the original edge remaining intact.

Reduction: The fragment has been crushed and near the break the section is distorted, with hammer marks visible on both faces in association with the indentations. There are also small tool marks, probably made by a chisel, evident on the piece. The metal appears strained and cracked in places as a result of the hammering which has been inflicted upon it.

20/51 (Acc. No. 93: 4-26: 100)

Description: Lower body and cutting edge of socketed axe.

Dimensions: Length (maximum): 66mm. Cutting edge: 45mm. Weight: 142.8g.

Patina: One face is a rough grey-green, with no details visible, while the other side shows more details.

Manufacture: No casting seam is visible along one side, but the detail here has been almost obliterated following corrosion buildup. On the other side the casting seam is obscured near the cutting edge, but it is possible to establish that it was obliterated close to the break. There is evidence of fine hammering visible where the patina is favourable, and the cutting edge is now crescentic in shape.

Use: The edge is very uneven, and is chipped and broken along its length, one corner now having a rounded appearance.

Reduction: There are marked indentations on either side at the break, causing significant distortion to the section at the break. No individual hammer indents can be seen.

20/52 (Acc. No. 93: 4-26: 97)

Description: Lower body and cutting edge of socketed axe.

Dimensions: Length (maximum): 64mm. Cutting edge: 45mm. Weight: 174.8g.

Patina: Rough, thick dark-green.

Manufacture: The walls are of uneven thickness, indicating core misalignment. There are no traces of any casting seams apparent anywhere on the piece. On one face, there are traces of fine hammering above the cutting edge (not illustrated) and on the other some isolated horizontal grinding marks are visible. The cutting edge seems well-expanded.

Use: The edge is badly burred along its length and is broken at one end.

Reduction: Hammer indents are clearly visible on the thicker wall, but similar evidence is not so clearly apparent upon the other face, though the wall here has been pushed inwards significantly and is now much distorted at the break.

20/53 (Acc. No. 93: 4-26: 94)

Description: Lower body and cutting edge of socketed axe.

Dimensions: Length (maximum): 65mm. Cutting edge: 49mm. Weight: 123.0g.

Patina: Rough grey-green, details obliterated.

Manufacture: No visible indications of the casting seams can be seen through the corrosion product. The blade is very well-expanded, almost crescentic.

Use: The blade appears unevenly worn, but the condition of the cutting edge cannot be determined through the corrosion product.

Reduction: The piece has been crushed and the section is now very distorted. There are no hammer indents surviving in association with the break, no doubt because all detail has been obscured by the build-up of the corrosion product.

20/54 (Acc. No. 93: 4-26: 96)

Description: Lower body and cutting edge of socketed axe.

Dimensions: Length (maximum): 53mm. Cutting edge: 44mm. Weight: 116.1g.

Patina: Rough grey-green, with some encrustation present.

Manufacture: The wall sections are of uneven thickness, indicating slight core misalignment. The casting seams have been obliterated over both sides, and there are some horizontal grinding marks on one face (not illustrated). The cutting edge has a crescentic appearance.

Use: The blade appears fine and seems reasonably sharp over its extent, with one slight notch present. The bevels occurring at either corner suggest that it has been resharpened.

Reduction: The section is slightly distorted, and a depression can be seen near the break. No hammer indents can be seen, probably on account of the corrosion buildup.

20/55 (Acc. No. 93: 4-26: 102)

Description: Lower body and cutting edge of socketed axe.

Dimensions: Length (maximum): 52mm. Cutting edge: 45mm. Weight: 93.7g.

Patina: Rough grey-green, with much encrustation present.

Manufacture: The casting seams are obscured by corrosion buildup on both sides. Some diagonal grinding marks are visible, and the cutting edge is crescentic in appearance.

Use: The cutting edge is good where it remains intact, but there are some extensive stretches of chipping and burring. This damage to the edge may appear exaggerated following the build-up and subsequent flaking away of the corrosion product.

Reduction: Both faces have been crushed, resulting in distortion of the body section. No individual hammer indents can be seen through the corrosion products.

20/56 (Acc. No. 93: 4-26: 101)

Description: Lower body and cutting edge of socketed axe.

Dimensions: Length (maximum): 52mm. Cutting edge: 49mm. Weight: 122.2g.

Patina: Some bronze remains visible, but much of the piece is covered by a layer of grey-green encrustation, and it now has a rather messy appearance.

Manufacture: No traces of the casting seams survive, and the patina does not obscure these areas, so they must have been removed. The cutting edge is crescentic in appearance.

Use: The edge of the blade still seems reasonable, though it appears blunt and chipped in places. This damage may have been exaggerated by later flaking of the corrosion product.

Reduction: There is no evidence which relates to this process. No hammer indents are visible, and the piece shows no distortion of the section at the break.

20/57 (Acc. No. 93: 4-26: 103)

Description: Lower body and cutting edge of socketed axe.

Dimensions: Length (maximum): 49mm. Cutting edge: 43mm. Weight: 79.6g.

Patina: Rough grey-green with much encrustation present. Details very much obscured.

Manufacture: No traces of the casting seams can be seen on either side, but the corrosion product obscures much detail here. The cutting edge is crescentic in shape.

Use: The blade has been resharpened and appears unevenly worn. The condition of the cutting edge cannot be assessed because much detail is hidden by the corrosion product.

Reduction: Both faces have been hammered, and the section is distorted as a result, though the nature of the corrosion product does not assist in the identification of details. There are small tool marks from a chisel or punch near the break on one face (illustrated).

20/58 (Acc. No. 93: 4-26: 99)

Description: Lower body and cutting edge of socketed axe.

Dimensions: Length (maximum): 42mm. Cutting edge: 33mm. Weight: 67.6g.

Patina: Rough mid-green, with greyish-brown patches. Details obliterated.

Manufacture: One wall seems slightly thinner at the break, indicating core misalignment. The blade seems blunt and narrow in shape, which might suggest that it was never used, but its asymmetrical shape indicates instead that it was hammered out ready for use, and it may even have been resharpened. On one side, the casting seam is visible for 10mm below the break, but has been obliterated beyond this point. The other side shows no traces, but the corrosion products are particularly thick here.

Use: The blade seems blunt and narrow. This might suggest that it was never used, though its uneven shape suggests otherwise.

Reduction: There are some possible hammer indents on one face (not illustrated).

20/59(93: 4-26: 104)

Description: Cutting edge from socketed axe.

Dimensions: Length (maximum): 42mm. Cutting edge: 47mm. Weight: 94.3g.

Patina: Rough pale-green, with much encrustation.

Manufacture: The faint trace of a casting seam is visible through the patina on one side, but it is hard to assess how well it was finished. On the other side, the seam has been completely obscured by the corrosion product. The cutting edge is crescentic in appearance.

Use: The edge appears uneven and is chipped over its length, but this latter damage may result at least in part from later buildup and loss of the corrosion products.

Reduction: No hammering can be seen through the patina, and the section shows no indications of distortion at the break.

20/60 (Acc. No. 93: 4-26: 105)

Description: Cutting edge from socketed axe.

Dimensions: Length (maximum): 39mm. Cutting edge: 41mm. Weight: 58.9g.

Patina: One face is a rough grey-green, with patches where fresh copper has been revealed through flaking of the corrosion product. The other appears more dense and smooth, though the details are obscured on both sides.

Manufacture: The casting seams have been obliterated over one side, and their condition is indeterminate on the other as a result of corrosion buildup. The blade is crescentic in shape.

Use: The cutting edge is still sharp over two-thirds of its length, but shows marked burring over the remainder.

Reduction: Both faces have been crushed, and as a result the section is distorted, though no hammer indents are evident through the corrosion product.

20/61 (Acc. No. 93: 4-26: 106)

Description: Cutting edge from socketed axe.

Dimensions: Length (maximum): 37mm. Cutting edge: 40mm. Weight: 68.3g.

Patina: Rough olive-green, with some light green encrustation. Details obscured.

Manufacture: The walls are uneven in section, indicating core misalignment. The casting seams have been completely obliterated on one side, with only vestigial traces surviving on the other, and the blade has been expanded.

Use: The cutting edge seems blunt and chipped over its length, but the nature of the corrosion product may have exaggerated this damage.

Reduction: There are some possible hammer indents on one face (not illustrated), but no marked distortion of the section has occurred.

20/62 (Acc. No. 93: 4-26: 107)

Description: Cutting edge from socketed axe.

Dimensions: Length (maximum): 37mm. Cutting edge: 38mm. Weight: 60.3g.

Patina: Rough dark-green, with encrustation present. Few details are visible.

Manufacture: The casting seams have been removed completely from both sides, and the blade is well-expanded.

Use: The cutting edge appears blunt, and this damage may be use-related, though the edge also seems rather distorted, perhaps through deliberate damage inflicted at a later point (see **Reduction** below).

Reduction: There are cracks running up from the cutting edge and, judging from the distortion of the edge, these seem likely to be related to this stage of the object's life-cycle. On both faces, the surface of the casting is covered with rough hammer indents. The section is crushed and distorted at the break, and some cracking of the metal has occurred in this area.

20/63 (Acc. No. 93: 4-26: 108)

Description: Cutting edge from socketed axe.

Dimensions: Length (maximum): 36mm. Cutting edge: 44mm. Weight: 63.7g.

Patina: Rough pale-green. Some of the corrosion product has flaked away in places to reveal fresh metal underneath.

Manufacture: The casting seams appear to have been virtually obliterated on both sides, though their condition is difficult to assess through the patina. The blade is crescentic.

Use: The cutting edge is chipped over much of its length, though some of this damage may be related to loss of the corrosion product in recent times. Where it remains intact, the edge appears blunt, and a large piece has been broken from it at one corner.

Reduction: There are no visible hammer indents and the section shows no distortion.

20/64 (Acc. No. 93: 4-26: 109)

Description: Cutting edge from socketed axe.

Dimensions: Length (maximum): 29mm. Cutting edge: 35mm. Weight: 21.3g.

Patina: Dense grey-green, one side obscured by massive lumps of corrosion.

Manufacture: Uneven wall thickness is evident, indicating core misalignment. The casting seams have been completely obliterated over both sides, and the blade has been expanded.

Use: The edge seems fairly blunt over its length, and is chipped in places, this latter damage having occurred in antiquity.

Reduction: Hammering is clearly visible in association with the break, and this has caused distortion of the section.

20/65 (Acc. No. 93: 4-26: 110)

Description: Cutting edge from socketed axe.

Dimensions: Length (maximum): 37mm. Cutting edge: 53mm. Weight: 77.9g.

Patina: Mainly dense olive, with some encrustation. Details reasonable.

Manufacture: No traces of the casting seams survive on either side. Horizontal grinding marks are visible over the cutting edge, and there is evidence of fine hammering in this area too. The blade is crescentic in appearance.

Use: The cutting edge is chipped along its length, with one significant notch present. The poor condition of the edge may result, at least in part, from later buildup and loss of the corrosion product.

Reduction: Both faces have been subject to hammering in the vicinity of the break, and this has caused substantial deformation of the section.

20/66 (Acc. No. 93: 4-26: 111)

Description: Cutting edge from socketed axe.

Dimensions: Length (maximum): 33mm. Cutting edge: 41mm. Weight: 53.3g.

Patina: Some dense dark-green patches occur, though most of the surface is a rough greyish-green. Details mostly obscured.

Manufacture: No traces of any casting seams survive. Fine hammering is visible near the break, and there are also horizontal grinding marks apparent in places. The blade is well-expanded.

Use: The blade is asymmetrical, indicating uneven wear. One half of the blade remains intact and fairly sharp, with just one small but sharp notch apparent here. Elsewhere, the cutting edge seems blunt, although much may be obscured by corrosion buildup. Since the blade appears uneven but is still reasonably sharp over much of its extent, it is possible to suggest that it was subject to resharpening not long before its deposition.

Reduction: Some hammering near the break may be linked with the fragmentation of the piece, though perhaps it was too subtly executed for it to be associated with this phase of the object's life-cycle.

20/67 (Acc. No. 93: 4-26: 112)

Description: Cutting edge from socketed axe.

Dimensions: Length (maximum): 32mm. Cutting edge: 42mm. Weight: 44.2g.

Patina: On one face, the original bronze remains visible in places, although lumps of pale-green encrustation are present along the cutting edge. The other face is completely covered by lumpy pale-green encrustation. Details are good where the bronze survives.

Manufacture: No traces of the casting seams survive on either side. On the face where the details are visible, there is evidence of fine hammering over the blade but no grinding marks can be seen here. The cutting edge is crescentic in appearance.

Use: The cutting edge seems rough but is still reasonably fine, the uneven condition of the blade probably being related - at least in part - to the nature of the corrosion product.

Reduction: Some of the hammering noted in 'Manufacture' above may be linked with this process, but this cannot be determined with any degree of confidence.

20/68 (Acc. No. 93: 4-26: 113)

Description: Cutting edge from socketed axe.

Dimensions: Length (maximum): 132mm. Cutting edge: 47mm. Weight: 47.1g.

Patina: Rough grey green, details almost completely obscured with encrustation.

Manufacture: Only a faint vestigial trace of one casting seam remains visible - elsewhere the piece is obscured by a buildup of corrosion products.

Use: None of the original cutting edge survives. The edge appears battered, but this is largely related to the recent buildup and subsequent flaking of the corrosion product.

Reduction: The piece appears very distorted over its extent, and may have been heated. This could explain the pitted appearance of the bronze, which appears to be in a far worse condition than any other object in this hoard. There is a slight depression in one face near the break, but if any hammering is present it has been obscured by the corrosion buildup.

20/69 (Acc. No. 93: 4-26: 93)

Description: Probable body fragment of socketed axe.

Dimensions: Length (maximum): 26mm. Width: 15mm. Weight: 34.4g.

Patina: Rough light-green, with much encrustation present. Details very much obscured.

Manufacture: There is a casting seam remaining visible and prominent on one side, while the other side is indeterminate as a result of corrosion build-up.

Use: Impossible to determine.

Reduction: The section appears crushed and distorted at both breaks. There are some likely hammer indents in association with this damage (illustrated), but the piece is now in poor condition and little can be determined with any confidence.

20/70 (Acc. No. 93: 4-26: 120)

Description: Butt fragment of looped palstave.

Dimensions: Length (maximum): 85mm. Weight: 205.7g.

Patina: Rough pale-green, with occasional patches of dense olive around the septum.

Manufacture: The seams appear to have been completely removed, though corrosion buildup has obscured much detail.

Use: Impossible to determine.

Reduction: There is no evidence relating to this process.

20/71 (Acc. No. 93: 4-26: 117)

Description: Butt fragment of winged axe, with a raised 'X' decoration visible between the wings on one side.

Dimensions: Length (maximum): 100mm. Weight: 222.5g.

Patina: Dense, polished olive, with some rough green-brown patches over the top surface and much of one face. Details locally good.

Manufacture: Fine hammering is visible in places on the underside. The feeder survives as a vestigial stump at the butt, which still has a rather rough appearance. Over the rest of the piece, however, the casting seams have been obliterated and some grinding marks on the underside may be linked with their removal. There is evidence of hammering in the vicinity of the wings, and there are some grinding marks running diagonally over the wings in places.

Use: Impossible to determine.

Reduction: There is a marked notch on the loop, which was probably inflicted during the separation of axehead and haft. A series of rough, long hammer indents near the the break are likely to have resulted during fragmentation.

20/72 (Acc. No. 93: 4-26: 116)

Description: Winged axe.

Dimensions: Length: 136mm. Cutting edge: 34mm. Weight: 368.4g.

Patina: Some areas are a smooth dark green/olive, while others are a rough pale-green. There is encrustation apparent around the loop.

Manufacture: The corrosion product obscures those areas where the casting seams would once have been, but it is likely that the seams have been completely removed, and this is why no traces can be seen through the patina. However, the casting seams appear to have survived around the edges of the wings, though they have been flattened here. Fine hammering can be seen on the wings, and also on the upper blade, and vertical grinding marks run down the length of the blade.

Use: The blade is rough and broken, with none of the original cutting edge remaining.

Reduction: The break along the cutting edge is unusually regular, and deliberate breakage cannot be ruled out, though no hammer indents can be seen in association.

20/73 (Acc. No. 93: 4-26: 114)

Description: Winged axe.

Dimensions: Length: 105mm. Cutting edge: 38mm (remaining). Weight: 273.6g.

Patina: Rough grey-green.

Manufacture: The casting seams appear to have been totally obliterated over the body. There are possible grinding marks on the underside of the piece, with others apparent below the depression on one face (not illustrated). Fine hammer working appears to have been carried out over much of the piece, and the upper and lower wings have now been hammered inwards so much that they are touching, and they now adhere to one another as a result of corrosion buildup. The blade is very well-expanded, appearing almost crescentic in shape.

Use: The edge is very poorly preserved, with roughly half of its length now missing.

Reduction: The butt is now missing. Hammer indents can be seen association with this damage, but these may be linked with manufacture rather than with the closing phases of the object's life-cycle.

20/74 (Acc. No. 93: 4-26: 115)

Description: Winged axe.

Dimensions: Length: 95mm. Cutting edge: 40mm. Weight: 156.3g.

Patina: Rough grey-green, with much encrustation apparent, especially around the blade. Details obliterated.

Manufacture: The casting seams appear to have been obliterated over the extent of the piece. The wings have been hammered so closely that they touch one another, and they now adhere to one another following corrosion build-up. The blade is well-expanded.

Use: The blade is unevenly worn, and its stubby appearance may indicate that it has been resharpened a number of times over its lifetime.

Reduction: There is no evidence relating to this process.

20/75 (Acc. No. 93: 4-26: 118)

Description: Butt fragment of winged axe.

Dimensions: Length (maximum): 74mm. Weight: 166.3g.

Patina: Rough dark-green, no details visible.

Manufacture: The casting seam has been removed over the loop, but elsewhere the details are indeterminate as a result of the corrosion buildup. The butt seems rough, as if poorly finished, and there is a possible hammer indent beneath one of the wings.

Use: Impossible to determine.

Reduction: One wing appears broken and distorted, but the nature of the patina makes it impossible to assess whether or not this damage was inflicted deliberately, though its association with a sizable notch missing from the wing makes use-related damage a possibility.

20/76 (Acc. No. 93: 4-26: 119)

Description: Blade fragment of palstave or winged axe. The latter seems more likely, as the fragmentary 'wing' seems to be of greater length than the side flange of a palstave would have been.

Dimensions: Length (maximum): 45mm. Weight: 83.1g.

Patina: Rough pale-green, with much encrustation. Details completely obscured.

Manufacture: Hammer indents are visible where the flange/wing joins the body, but no other evidence can be seen. The course of the casting seam is obscured through corrosion buildup.

Use: Impossible to determine.

Reduction: No hammering is apparent near the break, but the patina obscures much detail.

20/77 (Acc. No. 93: 4-26: 121)

Description: Upper blade fragment of winged axe, with butt and cutting edge now missing.

Dimensions: Length (maximum): 41mm. Weight: 131.7g.

Patina: Dense olive, details reasonable.

Manufacture: The casting seams have been obliterated. There is evidence of fine hammering along the sides, especially over the seams, and grinding marks can also be identified in this area. These traces are likely to have been inflicted during the removal of the seam. There are also traces of fine hammering in the indentation below the wings.

Use: Impossible to determine.

Reduction: No hammer indents can be seen in association with either of the breaks.

20/78 (Acc. No. 93: 4-26: 123)

Description: Solid-sectioned axe-blade, probably from a winged axe.

Dimensions: Length (maximum): 33mm. Weight: 55.6g.

Patina: Rough brownish-green on one side, smoother dark green on the other.

Manufacture: The casting seams have been removed. The blade does not appear to have been particularly well-expanded, and yet hollows are present over the corners. These are very pronounced, and run back almost to the break, giving a flanged appearance to the sides.

Use: The cutting edge is undulating and blunt in appearance, with some notches along its length, and a large piece missing from one corner. At least some of this damage may be use-related.

Reduction: Pronounced hammer indents can be seen all over the surface of the piece, and these may have contributed to the distorted appearance of the fragment. The blade edge may also have been subject to deliberate hammering in order to render it unusable. There appear to be grinding marks associated with the broken corner, though their purpose is unclear.

20/79 (Acc. No. 93: 4-26: 122)

Description: Blade fragment from winged axe.

Dimensions: Length (maximum): 57mm. Cutting edge: 42mm.

Patina: Dense grey-green, with some extensive patches of encrustation apparent. Details obscured.

Manufacture: No traces of any casting seams survive, and no other evidence from the manufacturing process can be identified.

Use: The cutting edge seems slightly uneven in appearance, but appears to remain in good condition over its length.

Reduction: There is no evidence relating to this process.

20/80 (Acc. No. 93: 4-26: 142)

Description: Fragment of bladed object. The blade seems wide, and has a lenticular section to the tang. The piece is probably a fragmentary tanged chisel.

Dimensions: Length (maximum): 50mm. Width: 31mm. Weight: 25.4g.

Patina: The piece is covered with light green patina - no detail is visible. This has flaked away in places, revealing fresh metal.

Manufacture: No traces of any casting seams can be identified, and no other evidence which relates to this process can be identified. A small hole in the piece, associated with fresh metal, has resulted from modern damage, i.e. drilling carried out for the recovery of a sample for analysis.

Use: Impossible to determine, as none of the edge survives.

Reduction: There is no evidence relating to this process.

20/81 (Acc. No. 93: 4-26: 140)

Description: Blade fragment of tanged chisel.

Dimensions: Length (maximum): 57mm. Cutting edge: 42mm. Weight: 63.2g.

Patina: Rough grey-green in most places, with occasional patches of bronze remaining, and much encrustation present.

Manufacture: Near the break on one side, a vestigial trace of the casting seam appears to remain prominent. No other evidence can be linked with this process.

Use: Impossible to determine.

Reduction: No hammering or distortion can be seen in association with break.

20/82 (Acc. No. 93: 4-26: 135)

Description: Fragment of sickle blade, with two ribs running parallel to the topmost edge. Its narrow width suggests that it came from a point near the tip of the blade.

Dimensions: Length (maximum): 40mm. Width: 28mm. Weight: 15.4g.

Patina: Some dense, olive patches remain, but some expanses of rough, light green encrustation are present.

Manufacture: No traces of the casting seam survive. Possible grinding marks run along the blade edge, which has a fine bevel running along its length.

Use: There is a tiny notch on the edge, which seems otherwise fine and sharp.

Reduction: There is a distinct bend in the profile at the upper break, i.e. that nearest the butt. This is especially apparent in the top rib, suggesting that a blow may have contributed to this distortion and the subsequent breakage, though no clear indications of hammering are evident. Corrosion buildup obscures much detail here, however.

20/83 (Acc. No. 93: 4-26: 141)

Description: Fragment of bladed object. The blade is double-edged, narrow in shape and thin in section. It therefore seems likely that this fragment originally came from a knife.

Dimensions: Length (maximum): 44mm. Weight: 19.2g.

Patina: The surface is covered with a dusty brown layer of corrosion, the details reasonable.

Manufacture: Small grinding marks run back from the cutting edge, and vertical examples can be seen running down the length of the piece.

Use: Where the edges remain intact, they seem fine, but they appear blunt in places. Isolated coarse striations run across the surface of the piece, and this damage might be use-related.

Reduction: The profile of the piece is straight. There is no distortion, and there are no clear indications of hammering at either break.

20/84 (Acc. No. 93: 4-26: 136)

Description: Socket and upper blade from a 'Thorndon' type socketed knife, with a single rivet hole on either side of the socket. In this example, the blade is plain.

Dimensions: Length (maximum): 64mm. Weight: 44.1g.

Patina: Rough green/brown mottled appearance, details largely obscured.

Manufacture: The casting seams are quite pronounced over the socket, but the blade is well-finished. Fine hammering is evident at the junction between the blade and the socket.

Use: The blade edges are rough and blunt in appearance, but their poor condition may be largely linked with later flaking of the corrosion products, as no notches are apparent.

Reduction: There is some breakage apparent at the mouth, and this is associated with some rough hammer indents.

20/85 (Acc. No. 93: 4-26: 13)

Description: Shoulders and upper blade of 'Ewart Park' type sword. Four rivet holes remain, one at the point of either shoulder, two in the tang. Only one of the latter is intact.

Dimensions: Length (maximum): 80mm. Weight: 80.3g.

Patina: Some patches of dense olive remain, with much grey-green encrustation present. Details poor.

Manufacture: No traces of any casting seams survive. There are some possible grinding marks visible in the vicinity of the ricasso, and a slight bevel is visible along the blade edges.

Use: The cutting edges, where they remain, seem good.

Reduction: There is a possible hammer indent at the lower break, and slight distortion of the profile is apparent.

20/86 (Acc. No. 93: 4-26: 12)

Description: Hilt and shoulders of 'Ewart Park' sword. There are three rivet holes present on either shoulder, but in only the lowermost example has the metal been fully punched through. There is an additional broken rivet hole visible in the tang at the break.

Dimensions: Length (maximum): 96mm. Weight: 137.0g.

Patina: Rough green, with a dusty brown covering. Details obscured.

Manufacture: As mentioned above, only two of the six rivet holes in the shoulder have been fully punched through. Some traces of the seam are apparent over the shoulders, and on one side a faint step in section is apparent, as if slight mismatching of the valves occurred. Some vertical grinding marks run down the blade, while others are apparent in the grooves where the rivet holes are situated. Bevels run down either cutting edge. There are indications of fine hammering over the tang, but these may be related to later processes (see below).

Use: One blade edge has a rather blunt appearance. It looks unsharpened, but the other side seems fine and remains relatively sharp, and this sharper edge is notched in one place. The rivet holes in the shoulder appear rough and rather strained.

Reduction: The hammering round the tang appears to have caused slight distortion of the tang, making the flanges seem flatter in this area. This suggests that it was inflicted as part of the reduction process, rather than during manufacture. There are possible hammer marks in association with the lower break on one side (not illustrated) but it is difficult to assess these with confidence, as the patina obscures more detail in this area.

20/87 (Acc. No. 93: 4-26: 15)

Description: Hilt and shoulders of 'Ewart Park' type sword. Two small rivet holes are present.

Dimensions: Length (maximum): 59mm. Weight: 73.7g.

Patina: Very rough pale-green, with a brownish covering adhering to it.

Manufacture: All the casting seams have been obliterated. The rivet holes are small, and have been punched through very close to the edge of the tang. The upper break has an odd appearance: part of it seems rough, with a fragmentary third rivet hole visible, but at the other side the metal appears very smooth and rounded. This may indicate a casting flaw, i.e. through an inadequate amount of molten metal being poured into the mould during casting.

Use: The cutting edges remain sharp and fine. One rivet hole seems slightly elongated, which may suggest strain, but little other evidence of use-related damage can be seen.

Reduction: A large notch near the uppermost break has a deep and elongated appearance, as if inflicted by a sharp-edged and rather heavy object, e.g. a socketed axe. This damage appears too sharp to have been made by a hammer, and too substantial to have been caused by a chisel. There are no clear hammer indents in association with the lower break.

20/88 (Acc. No. 93: 4-26: 14)

Description: Shoulders and upper blade of 'Ewart Park' type sword, with two rivet holes surviving.

Dimensions: Length (maximum): 58mm. Weight: 74.4g.

Patina: Rough, grey-green patina, details barely visible.

Manufacture: The surface appears to have been hammered, and no traces of any casting seams can be seen. No other evidence can be associated with this process.

Use: The rivet holes appear to be strained and torn through use. The edges, where they survive, are sharp, but considering their location near the hilt this is perhaps not surprising.

Reduction: The profile of the piece appears distorted. No hammer indents can be seen in association with either break, though the patina is thick and obscures much detail.

20/89 (Acc. No. 93: 4-26: 9)

Description: Shoulders and upper blade of 'Carp's Tongue' sword. Grooves emphasise the midrib, running outwards towards the lowermost rivet holes where the ricasso begins. There are four rivet holes in the shoulders, but only two have been punched through fully, the other two surviving as blanks. There are two additional rivet holes in the tang, one complete, the other fragmentary. These are much larger in size than those present in the shoulders.

Dimensions: Length (maximum): 115mm. Weight: 143.3g.

Patina: Rough light-green, details obscured.

Manufacture: No traces of any casting seams survive, and fine bevels run down both cutting edges. No other evidence can be linked with the manufacturing process.

Use: One slight notch is apparent on one cutting edge, but otherwise both edges seem fine and remain quite sharp.

Reduction: The profile is distorted, but no hammer indents are visible in association with either break.

20/90 (Acc. No. 93: 4-26: 11)

Description: Shoulders and upper blade of 'Carp's Tongue' sword. A groove which defines the midrib fades at the base of the tang. Two rivet holes are apparent on the shoulder, and these are set within a marked depression, which might have been intended for the insertion of several rivet holes, or even a slot. The remains of a slot are visible where breakage has taken place on the tang.

Dimensions: Length (maximum): 75mm. Weight: 124.4g.

Patina: Some dense olive patches remain, but most is a rough grey-green. Details are locally good.

Manufacture: Some fine hammering is visible on one shoulder, and grinding marks are apparent on the tang close to the break. The interior of the slot still remains rough, but elsewhere all seams appear to have been removed. There are indications of fine hammer work and also possible grinding marks on the flange at the edge of the tang.

Use: One rivet hole seems strained, and the upper break may be use-related. The edges seem good, but their extent is limited, and so little can really be said.

Reduction: There are no clear indications of deliberate destruction - the profile seems quite straight, and no hammering can be seen at either break. Some small tool marks on the hilt might be associated with the removal of the hilt plate, while coarse striations near the midrib result from recent damage.

20/91 (Acc. No. 93: 4-26: 10)

Description: Shoulders and upper blade of 'Carp's Tongue' sword. Grooves run parallel to either side of the midrib, and three rivet holes can be identified, with one rivet remaining in situ.

Dimensions: Length (maximum): 60mm. Weight: 82.7g.

Patina: Rough grey-green, with some patches of dense olive, where details survive better.

Manufacture: All the casting seams have been removed. Diagonal grinding marks are visible in places, and there are some indications of fine hammer working. A bevel is visible along one of the cutting edges.

Use: The cutting edge appears blunted and burred over much of its length, though the bevel can still be identified. On the other side, none of the edge survives intact. The poor condition of the lowermost rivet hole on one side might indicate use-related strain.

Reduction: A faint bend is apparent in the profile, but no hammer indents can be seen in association with either break, though this could be due to the nature of the patina.

20/92 (Acc. No. 93: 4-26: 16)

Description: Sword hilt, from hollow-sectioned sword. The tang is of solid-section, the hollow-section appearing at the base of the tang where the midrib begins. Three rivet holes are present in the tang, which seems unusually long in comparison to other examples.

Dimensions: Length (maximum): 97mm. Weight: 74.4g.

Patina: Rough grey-green, with thick encrustation in places.

Manufacture: All the casting seams have been neatly removed, but no other evidence can be identified.

Use: Impossible to determine, as no cutting edges survive.

Reduction: No evidence can be found which relates to this process.

20/93 (Acc. No. 93: 4-26: 18)

Description: Fragment of sword tang, with an incomplete slot surviving.

Dimensions: Length (maximum): 58mm. Weight: 27.6g.

Patina: Rough grey-green, little detail visible.

Manufacture: The interior of the slot seems rough and the end of the tang seems uneven, though no casting seams are visible. A slight flange runs down either edge of the tang, and there are traces of hammering in the hollow between these flanges.

Use: Impossible to determine, though use-related breakage cannot be discounted.

Reduction: No indications of any hammering are visible. The profile is straight, with no signs of distortion, though the section appears faintly twisted at the break. This latter observation supports the possibility of use-related damage.

20/94 (Acc. No. 93: 4-26: 17)

Description: Fragment of sword tang, with two rivet holes surviving, along with a third fragmentary example.

Dimensions: Length (maximum): 60mm.

Patina: Dense grey-green, but details are very good.

Manufacture: Traces of the casting seam survive across the top of the tang, but elsewhere the piece is well-finished. Fine hammering has been carried out over the upper part of the tang, and vertical grinding marks run down the length of the tang in the vicinity of the rivet holes.

Use: Impossible to determine.

Reduction: There is no evidence relating to this process.

20/95 (Acc. No. 93: 4-26: 29)

Description: Blade fragment of 'Ewart Park' type sword.

Dimensions: Length (maximum): 113mm. Weight: 125.4g.

Patina: Some bronze showing, but there are patches of rough, grey/green encrustation. Details are much obscured.

Manufacture: Fine hammering is evident on the blade and along the cutting edges, and some grinding marks can be seen in places (illustrated).

Use: The edges, where they remain intact, are notched and chipped, though some of this damage is the result of later flaking of the corrosion products.

Reduction: There is a marked 'S'-shaped bend to the profile of the piece, but no hammering is evident in association with either of the breaks.

20/96 (Acc. No. 93: 4-26: 35)

Description: Blade fragment of 'Ewart Park' type sword.

Dimensions: Length (maximum): 65mm. Weight: 74.6g.

Patina: Very rough grey-green, details obscured.

Manufacture: No details visible.

Use: The edges are very badly chipped, but their poor condition may be exaggerated through recent flaking of the corrosion product. Where they remain intact, they are thickened through corrosion build-up.

Reduction: The profile is virtually straight. There is a slight bend visible near the lower break, but no hammering is visible in association with either break.

20/97 (Acc. No. 93: 4-26: 31)

Description: Blade fragment of 'Ewart Park' type sword.

Dimensions: Length (maximum): 103mm. Weight: 113.3g.

Patina: Rough brownish-green, with one patch of polished dark-green patina surviving, where the detail is very good.

Manufacture: Vertical and horizontal grinding marks are visible in the vicinity of the midrib, and some fine hammering can be seen on the blade. The cutting edges are bevelled.

Use: The cutting edges are notched and chipped, although on one side especially this damage appears worse as a result of corrosion build-up and flaking.

Reduction: The profile is distorted, but no hammering can be seen in association with either break, quite possibly on account of corrosion build-up.

20/98 (Acc. No. 93: 4-26: 32)

Description: Blade fragment of 'Ewart Park' type sword.

Dimensions: Length (maximum): 104mm. Weight: 161.6g.

Patina: Rough grey-green, with encrustation over much of the piece. Details obscured.

Manufacture: There is some evidence of fine hammering over the blade.

Use: The edges are badly notched, with little of the original edge remaining on one side, and none present on the other. Some of this may be due to the build-up and subsequent loss of corrosion products, but it must surely reflect the object's original condition to some extent.

Reduction: There is a faint bow to the profile. No hammering can be seen, perhaps because of the corrosion buildup.

20/99 (Acc. No. 93: 4-26: 33)

Description: Blade fragment of 'Ewart Park' type sword.

Dimensions: Length (maximum): 70mm. Weight: 87.5g.

Patina: Dense dark-green, with some patches of encrustation. Details good.

Manufacture: Vertical grinding marks are evident over much of the piece, including the midrib, and the cutting edges, which have fine bevels running over their extent.

Use: The cutting edges seem good; on one side the edge appears rough near the lower break, but this may be due to localised corrosion build-up. One deep groove which runs across the blade apparently occurred in antiquity, and this is likely to be use-related damage.

Reduction: There is a slight bend to the profile, and there are faint indications of hammering in the vicinity of the upper break (not illustrated).

20/100 (Acc. No. 93: 4-26: 30)

Description: Blade fragment of 'Ewart Park' type sword.

Dimensions: Length (maximum): 83mm. Weight: 82.2g.

Patina: One side is a polished mid-green, and the details can be clearly seen here. The other is rougher, and here the details are obscured.

Manufacture: A faint bevel runs down the length of the cutting edges, and fine hammering can be seen over edges, bevels and midrib. There are also fine vertical grinding marks running down the piece.

Use: The cutting edge seems sharp over much of its length, but it is chipped in a number of places. This damage is often associated with reddish patches of fresh metal, and this suggests

that much may be the result of recent flaking of the corrosion product. A marked striation runs across the piece, and though the corrosion has flaked off in places here, it seems to date from antiquity and may represent use-related damage.

Reduction: There is a possible hammer indent located near the lower break (not illustrated) but this is only faintly discernible.

20/101 (Acc. No. 93: 4-26: 40)

Description: Fragment of 'Ewart Park' type sword blade.

Dimensions: Length (maximum): 45mm. Weight: 40.0g.

Patina: Very rough pale green. Details faintly visible.

Manufacture: Some vague indications of grinding marks are apparent, and the undulating appearance to the surface in one location probably results from fine hammering.

Use: The cutting edges still seem sharp, though there are several small chips and notches apparent along their length on both sides.

Reduction: There is a faint bend to the profile. There are no indications of hammering in association with the breaks, but the corrosion buildup may obscure much detail here.

20/102 (Acc. No. 93: 4-26: 42)

Description: Blade fragment of 'Ewart Park' type sword.

Dimensions: Length (maximum): 33mm. Weight: 34.9g.

Patina: Some patches of dense olive remain on one side, and in these areas the detail is good, while the rest is a rough mottled green/brown.

Manufacture: Fine hammering is visible on the blade edges, and slight bevels are visible, running along the cutting edges, though these show clearly on only one side. There are vertical and diagonal grinding marks visible in places on the blade.

Use: Both edges seem good, with no significant notches apparent. A deep, horizontal groove runs across one face, and another similar example runs vertically down the midrib. These may be use-related, as they seem too large and too heavy to have resulted from chisel-damage.

Reduction: There is little sign of distortion in the profile, but a possible hammer indent can be identified at one break.

20/103 (Acc. No. 93: 4-26: 37)

Description: Blade fragment of 'Ewart Park' type sword.

Dimensions: Length (maximum): 63mm. Weight: 78.7g.

Patina: Dense dark-green on one side, rough brownish-green the other. Details obscured.

Manufacture: A slightly rippled appearance to the cutting edges can be seen on the better-preserved of the two faces, and this appears to be the result of fine hammering of the blade. There may also be vertical striations running down the blade, but these cannot be confidently identified through the corrosion products.

Use: The edges are reasonable, one being virtually intact while the other seems a little rough. The rough appearance to the latter may be exaggerated by the nature of the corrosion product.

Reduction: Some possible hammer indents can be seen near the break, but the nature of the corrosion products makes it difficult to be confident of their validity.

20/104 (Acc. No. 93: 4-26: 36)

Description: Blade fragment of 'Ewart Park' type sword.

Dimensions: Length (maximum): 62mm. Weight: 64.7g.

Patina: Very rough pale-green, much encrustation apparent. Some dense green patches obscure detail over the edge on one side.

Manufacture: Diagonal grinding marks are visible on the cutting edge, and some hammering is evident in places on both sides.

Use: One of the cutting edges is obscured by corrosion products. The other remains fairly sharp, and is largely intact. Some burring is evident here, and several notches are visible over its extent.

Reduction: There is a bend to the profile, but there are no traces of hammering in association with either break. If any such marks were present, however, they may have been obscured by corrosion buildup.

20/105 (Acc. No. 93: 4-26: 34)

Description: Blade fragment of 'Ewart Park' type sword blade.

Dimensions: Length (maximum): 71mm. Weight: 84.8g.

Patina: Dense olive, with much of the surface covered by a thick brownish layer.

Manufacture: Fine hammering is visible over the piece, and vertical striations run down the blade in places.

Use: One cutting edge is largely fine, though some minor burring is apparent in a few places. The other edge sports two marked notches in its extent. These appear to have been caused through blows inflicted by another sharp object, such as another sword, perhaps.

Reduction: There is a notch in one edge which seems too large to have resulted from damage sustained through use. First impressions suggested that it was a casting flaw, but closer inspection revealed burring and distortion in its vicinity. It may therefore have been deliberately inflicted during this phase, and light hammering near the lower break appears too rough to be linked with manufacture. The profile is slightly bowed in appearance.

20/106 (Acc. No. 93: 4-26: 41)

Description: Blade fragment of 'Ewart Park' type sword.

Dimensions: Length (maximum): 38mm. Weight: 40.1g.

Patina: Rough pale-green, details totally obscured.

Manufacture: No evidence can be linked with this process.

Use: The cutting edge is chipped in places, but the patina differs here, suggesting that at least some of this damage may be later in date. Otherwise, the blade seems fine, though rather rough.

Reduction: There is a pronounced bend to the profile, but no traces of hammering can be seen, perhaps as a result of corrosion build-up.

20/107 (Acc. No. 93: 4-26: 39)

Description: Fragment of 'Ewart Park' sword blade.

Dimensions: Length (maximum): 51mm. Weight: 69.6g.

Patina: Some dense patches of dark green/olive are present, but much of the piece is now covered with a mottled light green/brown layer, associated with much encrustation. Details are good in the areas with a denser patina.

Manufacture: Some vertical grinding marks are visible in places. Hammering can be seen on the midrib and near the break, though some of this is roughly executed and is likely to be linked with the reduction process.

Use: The cutting edges cannot be assessed, as large areas of encrustation now obscure them.

Reduction: One side (illustrated) shows a considerable number of rough hammer indents near the lower break and around the edges. This hammering may have contributed in part to the poor condition of the cutting edges. Rough hammering halfway up the piece could be linked with the fragmentation of the object, though the profile shows little distortion.

20/108 (Acc. No. 93: 4-26: 143)

Description: Fragment of blade from a lenticular-sectioned object, possibly a 'Ewart Park' type sword, though the section seems unusually thin and insubstantial. The piece seems too broad, however, to be a fragmentary knife blade.

Dimensions: Length (maximum): 25mm. Weight: 15.6g.

Patina: The piece is covered with rough, grey-green encrustation.

Manufacture: No details relating to this process can be identified.

Use: One edge seems to be largely intact, while the other is in poorer condition. However, it is difficult to be make any confident assessments, as corrosion products obscure the cutting edges.

Reduction: There is no evidence relating to this process.

20/109 (Acc. No. 93: 4-26: 38)

Description: Blade fragment of 'Ewart Park' sword.

Dimensions: Length (maximum): 63mm. Weight: 97.8g.

Patina: Some dense dark-green patches remain, but the piece is mostly a rough green/brown colour. Details are obscured over much of the piece.

Manufacture: Some horizontal grinding marks are visible in a few places on the blade, and there are also some diagonal examples running back from the cutting edges. These, however are not as small and fine as those noted on other examples. Faint bevels run down either cutting edge.

Use: There is a pronounced notch on one of the edges. This is of unusual form, as it consists of several minor indentations surrounding one more substantial example, and this would indicate that several blows were aimed at the the same spot. These blows seem to have been caused by a relatively blunt object, such as a hammer, and may have occurred during manufacture.

Reduction: No evidence of hammering can be seen at either break, though the metal here has been obscured by the corrosion product.

20/110 (Acc. No. 93: 4-26: 19)

Description: Blade tip, probably from 'Ewart Park' type sword.

Dimensions: Length (maximum): 120mm. Weight: 98.2g.

Patina: Mainly a dense dark-green, with some rougher patches. Details are very much obscured.

Manufacture: The surface has been subject to fine hammering over its extent, and there are faint bevels running along the cutting edges, but no grinding marks can be identified.

Use: One edge is reasonably fine, with one or two slight notches apparent. The other is badly chipped, although the nature of the patina here is different, suggesting that earlier damage may have been exaggerated as a result of the build-up and subsequent flaking of the corrosion product in more recent times.

Reduction: There is a marked 'S'-shaped bend to the profile, and some rough hammer indents are clearly visible at the break.

20/111 (Acc. No. 93: 4-26: 20)

Description: Lower blade fragment of 'Ewart Park' sword, with the tip now absent.

Dimensions: Length (maximum): 52mm. Weight: 42.8g.

Patina: Mainly dense olive in colour, but some rougher brown patches are present. Details obscured.

Manufacture: Faint bevels are apparent on either blade edge. No grinding marks can be clearly identified, though there are some possible examples of vertical striations running down the blade in places. The surface appears to have been finely hammered, especially in the vicinity of the bevels.

Use: The edges seem reasonably sharp and fine, but there are one or two notches present in places.

Reduction: The blade profile is slightly bowed, and there is one possible hammer indent near the lower break, though this cannot be identified with certainty as a result of corrosion buildup.

20/112 (Acc. No. 93: 4-26: ?)

Description: Fragment of sword tip, now in very poor condition. It has come from a leaf-shaped sword, possibly of 'Ewart Park' type, but part of what appears to be a groove can be seen to define the midrib in one place.

Dimensions: Length (maximum): 52mm.

Patina: Rough grey-green, with much encrustation evident. No details visible.

Manufacture: No evidence relating to this process can be identified through the patina.

Use: Impossible to determine on account of corrosion buildup.

Reduction: No evidence relating to this process can be seen through the corrosion.

20/113 (Acc. No. 93: 4-26: 27)

Description: Blade fragment of 'Carp's Tongue sword', with grooves defining the midrib.

Dimensions: Length (maximum): 58mm. Weight: 71.5g.

Patina: Dense dark-green on one face, with much encrustation evident on the other. Details reasonable.

Manufacture: Hammering is evident over the midrib and over the edges, which are finely bevelled, and some grinding marks can be identified. The latter must remain tenuous, however, as they are obscured by numerous scratches which date to more recent times.

Use: The cutting edges seem fine and sharp. No notches are apparent, though the edges are obscured in places by the buildup of corrosion products.

Reduction: Some hammer indents can be seen in association with the breaks, but it is difficult to determine whether these are related to manufacture or fragmentation. Some located near the lower break appear to have been roughly executed, suggesting the latter. The profile of the blade appears slightly distorted.

20/114 (Acc. No. 93: 4-26: 25)

Description: Blade fragment of 'Carp's Tongue' sword blade, with grooves defining both the midrib and the blade edges.

Dimensions: Length (maximum): 84mm. Weight: 75.6g.

Patina: A polished dark green layer covers much of the piece, but some rough green encrustation has accumulated in places. Details locally excellent.

Manufacture: Vertical grinding marks run down the blade and the midrib. There are also fine grinding marks running diagonally back from the cutting edge, which is bevelled. The surface has been finely hammered in places (not illustrated). Some pitting is apparent in the bronze, which might suggest that the casting was not of a particularly high quality.

Use: The cutting edges are notched and chipped in places, but much of the original edge is still in a reasonable condition.

Reduction: A few small hammer or trunion chisel marks can be seen on the midrib and also on one side of the blade (illustrated). Another cluster of small tool marks, perhaps made by a punch, are visible near the lower break (not illustrated), and the profile of the piece appears distorted.

20/115 (Acc. No. 93: 4-26: 21)

Description: Blade fragment of 'Carp's Tongue' sword, with grooves defining the midrib.

Dimensions: Length (maximum): 52mm. Weight: 71.4g.

Patina: Dense olive, with some lumps of pale green encrustation on one face.

Manufacture: Grinding marks run diagonally across one face, and also run back from the cutting edge, which is finely bevelled, and vertical striations can be seen within the grooves that define the midrib. Fine hammering is evident over the bevels.

Use: The cutting edges remain largely intact over their extent. Some slight notches are visible, and some isolated striations are evident on the midrib in places.

Reduction: The cutting edge appears distorted near one of the breaks, and some possible hammer indents are visible in association, suggesting deliberate damage.

20/116 (Acc. No. 93: 4-26: 28)

Description: Blade fragment of 'Carp's Tongue' sword, with grooves defining the midrib.

Dimensions: Length (maximum): 33mm. Weight: 38.4g.

Patina: Bronze remains visible over one face, the rest being a rather rough light green. Details are difficult to determine.

Manufacture: There is no evidence relating to this process, perhaps as a result of later mutilation.

Use: This is impossible to determine, as the surviving portion of the edge is much distorted, partly through hammering, and partly through later buildup of the corrosion product.

Reduction: Where the blade survives, it appears undulating and deformed as a result of hammering. The midrib remains largely undamaged, although slight indentations can be identified near the upper break. There are also some hammer indents running down the broken edge of the midrib, probably inflicted during the separation of midrib and blade.

20/117 (Acc. No. 93: 4-26: 24)

Description: Blade fragment of 'Carp's Tongue' sword, with grooves defining the midrib.

Dimensions: Length (maximum): 35mm. Weight: 35.2g.

Patina: Mainly smooth olive, with some patches of encrustation present.

Manufacture: Vertical grinding marks run down the blade and the midrib.

Use: One edge is in good condition, with a few notches evident, while the other seems quite badly chipped, though where it survives it remains sharp.

Reduction: Hammer indents are apparent near the lower break.

20/118 (Acc. No. 93: 4-26: 22)

Description: Blade fragment of 'Carp's Tongue' sword, with grooves defining the midrib.

Dimensions: Length (maximum): 27mm. Weight: 29.2g.

Patina: Rough grey-green. No details visible.

Manufacture: There is no evidence relating to this process.

Use: The cutting edges seem blunt, and are notched in places.

Reduction: Two hammer indents can be seen in association with the upper break, and slight distortion of the profile is apparent.

20/119 (Acc. No. 93: 4-26:23)

Description: Blade fragment of 'Carp's Tongue' sword, with grooves defining the midrib.

Dimensions: Length (maximum): 24mm. Weight: 36.3g.

Patina: Rough grey-green, with some smoother olive patches.

Manufacture: Diagonal and vertical striations are visible along the cutting edges in places.

Vertical grinding marks can be seen within the grooves that define the midrib.

Use: The cutting edges are badly notched along their length, and appear slightly distorted.

Reduction: The edges look as though they have been deliberately hammered, and hammer indents are apparent in association with both breaks.

20/120 (Acc. No. 93: 4-26: 144)

Description: Fragmentary purse-chape. Its rounded shape and top edge are still apparent although the piece has been completely crushed.

Dimensions: Length (maximum): 30mm. Weight: 10.7g.

Patina: Rough grey-green, but fresh metal is revealed in places, and the cracks which cross the surface (illustrated) appear to have occurred in recent times.

Manufacture: The casting seams have been removed, but nothing else can be linked with this process.

Use: Impossible to determine.

Reduction: The piece has been hammered flat, and on one side (not illustrated) the metal is folded in places as a result. Some hammer indents can be seen, though these seem too fine to be associated with the reduction process.

20/121 (Acc. No. 93: 4-26: 125)

Description: Leaf-shaped socketed spearhead, with two rivet holes in the socket.

Dimensions: Length: 145mm. Weight: 90.5g.

Patina: Rough brownish-green, with some olive patches. Details reasonable.

Manufacture: Vertical grinding marks are apparent, running down the length of the piece at the junctions between midrib and blade. The casting seams have been completely removed over the entire piece, which appears beautifully finished.

Use: The cutting edges are badly notched and chipped along their extent on both sides.

Reduction: The object is complete, and there is no evidence relating to this process.

20/122 (Acc. No. 93: 4-26: 124)

Description: Leaf-shaped socketed spearhead, with a slightly stumpy appearance, and with an incised decoration encircling the base of the socket.

Dimensions: Length: 88mm. Weight: 36.7g.

Patina: Much of the blade is covered with a rough, grey-green patina, but some of the midrib on one face (illustrated), and much of the socket, is a dense olive. Details reasonable.

Manufacture: Vertical grinding marks are visible on the midrib. They are especially apparent at the junctions where blade and midrib conjoin. The casting seams have been completely removed, and the piece appears well finished.

Use: The cutting edges are basically good, though there is one slight notch near the tip and another more substantial example nearer the socket. A hole in the midrib may indicate use-related damage. This may have occurred when a loosely-attached shaft moved around in the socket, weakening and ultimately breaking the metal here. The nature of this damage may indicate that the metal is thinner here, i.e. through core misalignment, though later breakage cannot be discounted. The rivet holes show no signs of strain.

Reduction: No deliberate damage is apparent, though it is possible that the hole in the midrib was inflicted during this stage of the object's life-cycle. The lack of hammer indents in association with the break might, however, argue against this possibility.

20/123 (Acc. No. 93: 4-26: 126)

Description: Leaf-shaped socketed spearhead, with two rivet holes in the socket.

Dimensions: Length: 110mm. Weight: 86.7g.

Patina: Some patches of dense olive-green patina are present around the midrib and the socket in places, but most of the piece is covered by a layer of thick grey-green encrustation.

Manufacture: The bronze appears pitted in places, which suggests a poor quality casting, but the piece is well-finished. Fine hammering is evident on the midrib, and no traces of any casting seams survive.

Use: One edge remains reasonably fine and sharp. The other is notched and chipped along its length, especially near the tip, although the lower portion of the blade has survived largely intact. This damage might also have been exaggerated through flaking of the corrosion products. A crack runs up one side of the socket through the rivet hole, and the other rivet hole appears enlarged and slightly strained.

Reduction: The piece, though broken, survives as a complete object, but the socket has been blocked following the insertion of additional fragments. A flat piece of bronze with a faintly lenticular section - possibly a knife blade fragment - has been jammed into the socket, along with lumps of rough metal or copper ingot. It is possible that the socket was in-filled with molten metal.

20/124 (Acc. No. 93: 4-26: 127)

Description: Lower blade and socketed of leaf-shaped socketed spearhead.

Dimensions: Length (maximum): 82mm. Weight: 49.1g.

Patina: Rough grey-green, with much encrustation present. Details much obscured.

Manufacture: Small holes are apparent in places on the midrib, and their presence suggests that the casting may have been of poor quality. Vertical grinding marks are visible in places, running down the length of the midrib in those areas where the surface has not been obscured following corrosion buildup. The edge of the socket seems rather rough, and this may indicate poor finishing, but no traces of any casting seams remain elsewhere. Both cutting edges are finely bevelled.

Use: One rivet hole has largely been obscured by corrosion buildup, while the other seems a little strained and pulled. The edges appear notched in places, but this damage may have been exaggerated by flaking of the corrosion products.

Reduction: There is a possible hammer indent associated with the break (illustrated), but its presence must remain doubtful on account of the patina.

20/125 (Acc. No. 93: 4-26: 128)

Description: Incomplete lower blade and socket of leaf-shaped socketed spearhead.

Dimensions: Length (maximum): 62mm. Weight: 31.9g.

Patina: Mainly dense olive, with some patches of grey-green encrustation in places. Details reasonable.

Manufacture: No traces of the casting seams survive. The cutting edge is finely bevelled, and fine hammering can be seen in association with this. A cluster of long vertical grinding marks run up the interfaces between blade and midrib.

Use: The edge, where it remains intact, is in good condition.

Reduction: At the lower break, the section is distorted, and the metal has split down the length of the socket in the vicinity of the rivet holes. Hammer indents are visible in association with this damage. Further up the piece, at a point roughly halfway up the length of the fragment, the midrib is slightly distorted, and two additional hammer indents are apparent here. Towards the upper break, the midrib has been flattened, and the blade has been separated from the midrib on one side.

20/126 (Acc. No. 93: 4-26: 129)

Description: Upper blade fragment from leaf-shaped socketed spearhead.

Dimensions: Length: 75mm (maximum). Weight: 61.4g.

Patina: Very rough grey-green, details obscured.

Manufacture: Some vertical grinding marks can be seen running down the blade, but no other evidence can be identified which relates to this process.

Use: The cutting edges are very battered and chipped in appearance. Much of this damage appears to be linked with recent flaking of the corrosion products, but some notches appear to have originated in antiquity.

Reduction: A thin metal object, possibly a fragmentary knife blade, appears to have been jammed into the hollow-sectioned midrib of the spearhead. There appear to be notches superimposed upon the break, and it seems likely that this damage was caused by striking the piece repeatedly with a sharp tool such as a chisel after fragmentation took place.

20/127 (Acc. No. 93: 4-26: 131)

Description: Middle blade fragment of socketed spearhead.

Dimensions: Length (maximum): 40mm. Weight: 28.9g.

Patina: Rough grey-green, with occasional patches of dull olive. No details visible.

Manufacture: The core may have been misaligned, but no other evidence can be identified.

Use: The cutting edges seem reasonably fine. There are a few tiny notches occurring in isolation on both edges, but this damage seems fairly minor.

Reduction: On one face (illustrated), the midrib has been crushed following a single blow from a long, heavy, sharp-bladed object, perhaps an axe. On the other face (not illustrated) hammering can be seen near the breaks. The profile now seems slightly distorted. The hole in the midrib may have originated in antiquity, and may represent a casting defect. This may not be the case, though, as fresh metal shows around its edges, thus suggesting that the damage originated in recent times, i.e. through loss of corrosion products. Nonetheless, the break reveals the wall here to be very thin in section, indicating core misalignment.

20/128 (Acc. No. 93: 4-26: 130)

Description: Middle blade fragment of socketed spearhead.

Dimensions: Length (maximum): 37mm. Weight: 28.1g.

Patina: Rough grey-green, with some smoother olive patches. Details largely obscured.

Manufacture: A slight bevel is visible at the edge of the blade, but no other evidence can be linked with this process.

Use: The cutting edges are notched in places. Some of this damage took place in antiquity, while the remainder seems to have resulted from recent flaking of the corrosion products.

Reduction: On one face (illustrated), the midrib is distorted in four different places, having been struck by a blunt object such as a hammer or trunion chisel. A few hammer indents are visible towards the lower break, but elsewhere the patina obscures much detail. The other face shows one minor hammer indent at the upper break and a number of superimposed marks at the lower break. The midrib has been crushed on both sides at the lower break.

20/129 (Acc. No. 93: 4-26: 132)

Description: Bugle-shaped object, with broad loop.

Dimensions: Length: 58mm. Weight: 35.4g.

Patina: Dark-green on one face, while the other is a rougher brown/green. Details much obscured.

Manufacture: Faint traces of the seam can be seen on the interior of the loop, but they have been obliterated elsewhere. Where the corrosion does not obscure the surface, the metal appears smooth and polished in appearance.

Use: The slot seems rather misshapen in one corner, which might indicate wear, but otherwise the piece seems good. An isolated coarse striation is visible on one face.

Reduction: The object is complete, and there is no evidence relating to this process.

20/130 (Acc. No. 93: 4-26: 133)

Description: Bugle-shaped object, with narrow loop. A groove defines the junction between the tube and the loop, and the opening of the slot has been emphasised by a raised rib.

Dimensions: Length: 67mm. Weight: 24.6g.

Patina: Rough grey-green, with some lighter patches and some bronze showing through. Details locally reasonable.

Manufacture: Some possible grinding marks can be seen in the interior of the loop (not illustrated). The casting seams have been totally removed from the piece, although a slight ridge running around the exterior of the loop indicates its original location.

Use: There is no evidence relating to this stage of the object's life-cycle.

Reduction: The object is complete, and there is no evidence relating to this process.

20/131 (Acc. No. 93: 4-26: 134)

Description: Bugle-shaped object, with narrow loop.

Dimensions: Length: 58mm. Weight: 25.8g.

Patina: Rough grey-green patches of encrustation are evident, with some more dense olive patches present. Details reasonable.

Manufacture: There appear to be traces of the clay core still adhering inside the piece. A ridge in the section denotes the original path of the casting seam, although it has been flattened and ground over its extent. There are some possible small horizontal grinding marks near the top of the tube, and the surface of the loop seems to undulate slightly, which suggests that the surface has been subject to fine hammering.

Use: No evidence can be associated with this stage in the object's life-cycle.

Reduction: There is no evidence relating to this process.

20/132 (Acc. No. 93: 4-26: 139)

Description: Described by the NBI as a 'flanged collar', this object comprises a sub-circular bronze ring, with a raised portion in the centre. It may have functioned as some kind of washer, perhaps fulfilling a role as a component part of a larger object.

Dimensions: 38 x 31mm. Weight: 25.3g.

Patina: Mainly dense olive-green, with some rougher patches.

Manufacture: The casting seam remains obtrusive within the central ring, giving a stepped appearance to the interior. The exterior appears smooth and well-finished, though no specific details can be seen which can be linked with manufacture.

Use: The uppermost edge of the central section is uneven in height, and this seems likely to be use-related wear. There are notches missing from the exterior of the object. These blemishes were caused in antiquity, and may result from use-related damage.

Reduction: There is no evidence relating to this stage in the object's life-cycle.

20/133 (Acc. No. 93: 4-26: 138)

Description: Hog-backed knife.

Dimensions: Length: 78mm. Width: 39mm. Weight: 71.3g.

Patina: Smooth, polished olive, with some patches of grey-green encrustation. Details locally excellent.

Manufacture: Horizontal grinding marks run across both faces just above the cutting edge. There are also vertical grinding marks running down from the central slot, and some hammer indents are visible here, too. Tiny vertical grinding marks which run perpendicular to the cutting edge in places are likely to be linked with the sharpening of the blade.

Use: The piece bears a number of coarse grooves and scratches. The cutting edge appears very blunt in appearance, and both lateral ends are battered and chipped. On one side, however, fresh metal is apparent, and this indicates modern damage.

Reduction: There are some possible hammer indents apparent along the cutting edge, which appears slightly distorted in places. This could be deliberate damage linked with the closing stages of the object's life-cycle.

20/134 (Acc. No. 93: 4-26: ?)

Description: Fragment of tanged razor.

Dimensions: Length (maximum): 34mm.

Patina: Rough grey-green, details reasonable.

Manufacture: Some grinding marks are evident, running diagonally across the surface, and a fine bevel runs along the surviving length of the cutting edge.

Use: The cutting edge, where it survives, seems good, but it is difficult to assess the object's overall condition from this.

Reduction: There is no evidence relating to this process.

20/135 (Acc. No. 93: 4-26: 137)

Description: Incomplete socketed hammer.

Dimensions: Length (maximum): 55mm. Weight: 64.7g.

Patina: Mid grey-green. Details obliterated.

Manufacture: Traces of the casting seam still remain visible along one side, its line exaggerated here by corrosion buildup. No other details can be determined.

Use: Impossible to determine on account of the corrosion buildup, though it is possible that the breakage was use-related, as no distortion of the section is apparent at the break.

Reduction: There is no evidence relating to this process.

20/136 (Acc. No. 93: 4-26: 147)

Description: Casting jet from an unknown implement, comprising an extensive reservoir of bronze with one substantial feeder leading from it.

Dimensions: Weight: 106.3g.

20/137 (Acc. No. 93: 4-26: 146)

Description: Casting jet and reservoir of bronze. Two feeders lead from it, and the object probably originated during the casting of a smaller piece such as a socketed gouge or spearhead.

Dimensions: 26 x 22mm. Weight: 32.7g.

20/138 (Acc. No. 93: 4-26: 145)

Description: Casting jet from an unknown object, comprising a hemispherical reservoir of bronze with three feeders leading from it.

Dimensions: 27 x 28mm. Weight: 38.4g.

20/139 (Acc. No. 93: 4-26: 149)

Description: Casting jet, with one feeder apparent.

Dimensions: Length: 21mm. Weight: 10.4g.

20/140 (Acc. No. 93: 4-26: 148)

Description: Casting jet, with one feeder apparent.

Dimensions: Length: 30mm. Weight: 18.0g.

20/141 (Acc. No. 93: 4-26: 151)

Description: Large piece from edge of copper ingot.

Dimensions: Length: 125mm. Width: 85mm. Thickness: 31mm. Weight: 1323.9g.

Observations: Striations around the edge reveal fresh metal, and can therefore be linked with modern damage, e.g. preparation for metallographic analysis.

20/142 (Acc. No. 93: 4-26: 151)

Description: Piece from edge of copper ingot.

Dimensions: Length: 74mm. Width: 76mm. Thickness: 31mm. Weight: 675.4g.

20/143 (Acc. No. 93: 4-26: 151)

Description: Piece from interior of copper ingot.

Dimensions: Length: 75mm. Width: 70mm. Thickness: 21mm. Weight: 783.1g.

20/144 (Acc. No. 93: 4-26: 151)

Description: Piece from edge of copper ingot, with large voids visible in the metal.

Dimensions: Length: 70mm. Width: 63mm. Thickness: 30mm. Weight: 484.8g.

20/145 (Acc. No. 93: 4-26: 151)

Description: Piece from edge of copper ingot.

Dimensions: Length: 90mm. Width: 65mm. Thickness: 30mm. Weight: 1157.7g.

Observations: Two deep grooves are visible on the flatter surface, and in addition there are many shallow striations present on the more rounded surface (illustrated). This damage took place in antiquity, and it suggests that the fragment was used as a cutting or striking platform.

20/146 (Acc. No. 93: 4-26: 151)

Description: Piece from edge of thin-sectioned copper ingot.

Dimensions: Length: 74mm. Width: 63mm. Thickness: 15mm. Weight: 223.5g.

Observations: On one face a marked indentation is apparent (not illustrated). A few deep striations are also evident here, and similar marks can be identified on a ridge situated

immediately next to this indentation. These run both horizontally and vertically, and may either be chisel marks associated with the break-up of the ingot, or evidence that the piece was used as a striking platform.

20/147 (Acc. No. 93: 4-26: 151)

Description: Piece from interior of copper ingot.

Dimensions: Length: 80mm. Width: 63mm. Thickness: 25mm. Weight: 599.6g.

20/148 (Acc. No. 93: 4-26: 151)

Description: Piece from edge of copper ingot, with large voids visible in the piece.

Dimensions: Length: 70mm. Width: 63mm. Thickness: 26mm. Weight: 484.8g.

20/149 (Acc. No. 93: 4-26: 151)

Description: Small piece from edge of copper ingot.

Dimensions: Length: 60mm. Width: 55mm. Thickness: 19mm. Weight: 424.2g.

20/150 (Acc. No. 93: 4-26: 151)

Description: Small piece from edge of copper ingot, with voids present in the interior.

Dimensions: Length: 64mm. Width: 42mm. Thickness: 23mm. Weight: 292.3g.

20/151 (Acc. No. 93: 4-26: 151)

Descriptions: Fragment from edge of copper ingot.

Dimensions: Length: 35mm. Width: 35mm. Thickness: 26mm. Weight: 165.4g.

Observations: Part of one surface seems very smooth, and closer inspection revealed hammer marks in this area (illustrated).

20/152 (Acc. No. 93: 4-26: 151)

Description: Small piece from edge of copper ingot.

Dimensions: Length: 46mm. Width: 41mm. Thickness: 15mm. Weight: 175.1g.

Observations: There is a pronounced notch in the underside which appears to have originated in antiquity. This damage may have been inflicted during the fragmentation process.

20/153 (Acc. No. 93: 4-26: 151)

Description: Piece from edge of copper ingot.

Dimensions: Length: 67mm. Width: 42mm. Thickness: 27mm. Weight: 597.8g.

Observations: On one surface (not illustrated), several clusters of small tool marks are apparent, and these were probably inflicted by a chisel. At the interface between this face and the adjoining side, there appear to be slight hammer indents present. There is also a large blunt notch, and it is likely that this damage also resulted from a hammer blow.

20/154 (Acc. No. 93: 4-26: 151)

Description: Small piece from edge of copper ingot.

Dimensions: Length: 52mm. Width: 45mm. Thickness: 16mm. Weight: 131.3g.

Observations: Part of one face seems smooth, and the metal appears slightly cracked here (not illustrated). This suggests that the surface was hammered, perhaps during fragmentation.

20/155 (Acc. No. 93: 4-26: 151)

Description: Small piece from edge of copper ingot.

Dimensions: Length: 65mm. Width: 42mm. Thickness: 24mm. Weight: 304.7g.

20/156 (Acc. No. 93: 4-26: 151)

Description: Small piece from edge of copper ingot.

Dimensions: Length: 52mm. Width: 38mm. Thickness: 18mm. Weight: 251.4g.

20/157 (Acc. No. 93: 4-26: 151)

Description: Small piece from edge of copper ingot.

Dimensions: Length: 45mm. Width: 40mm. Thickness: 24mm. Weight: 180.4g.

20/158 (Acc. No. 93: 4-26: 151)

Description: Small piece from interior of copper ingot.

Dimensions: Length: 63mm. Width: 43mm. Thickness: 25mm. Weight: 356.7g.

20/159 (Acc. No. 93: 4-26: 151)

Description: Small piece from edge of copper ingot.

Dimensions: Length: 45mm. Width: 42mm. Thickness: 24mm. Weight: 198.2g.

20/160 (Acc. No. 93: 4-26: 151)

Description: Edge fragment of copper ingot.

Dimensions: Length: 42mm. Width: 37mm. Weight: 164.8g.

20/161 (Acc. No. 93: 4-26: 151)

Description: Fragment from edge of copper ingot.

Dimensions: Length: 64mm. Width: 42mm. Thickness: 29mm. Weight: 232.0g.

20/162 (Acc. No. 93: 4-26: 151)

Description: Small piece from edge of copper ingot.

Dimensions: Length: 35mm. Width: 35mm. Thickness: 25mm. Weight: 165.4g.

Observations: Part of one face seems smooth, and closer inspection revealed hammer indents in this area (illustrated).

20/163 (Acc. No. 93:4-26: 151)

Description: Fragment from interior of thin-sectioned copper ingot.

Dimensions: Length: 36mm. Width: 25mm. Thickness: 11mm. Weight: 93.9g.

20/164 (Acc. No. 93: 4-26: 151)

Description: Small fragment from edge of copper ingot.

Dimensions: Length: 33mm. Width: 24mm. Thickness: 24mm. Weight: 79.7g.

20/165 (Acc. No. 93: 4-26: 151)

Description: Small fragment from interior of copper ingot.

Dimensions: Length: 35mm. Width: 28mm. Thickness: 13mm. Weight: 78.6g.

20/166 (Acc. No. 93: 4-26: 151)

Description: Small fragment from edge of copper ingot.

Dimensions: Length: 36mm. Width: 35mm. Thickness: 14mm. Weight: 100.8g.

20/167 (Acc. No. 93: 4-26: 151)

Description: Small fragment from edge of copper ingot.

Dimensions: Length: 44mm. Width: 40mm. Thickness: 23mm.

20/168 (Acc. No. 93: 4-26: 151)

Description: Small fragment from edge of copper ingot.

Dimensions: Length: 33mm. Width: 12mm. Thickness: 25mm. Weight: 64.4g.

20/169 (Acc. No. 93: 4-26: 151)

Description: Fragment from edge of copper ingot.

Dimensions: Length: 55mm. Width: 43mm. Thickness: 15mm. Weight: 211.4g.

20/170 (Acc. No. 93: 4-26: 151)

Description: Small fragment from edge of copper ingot.

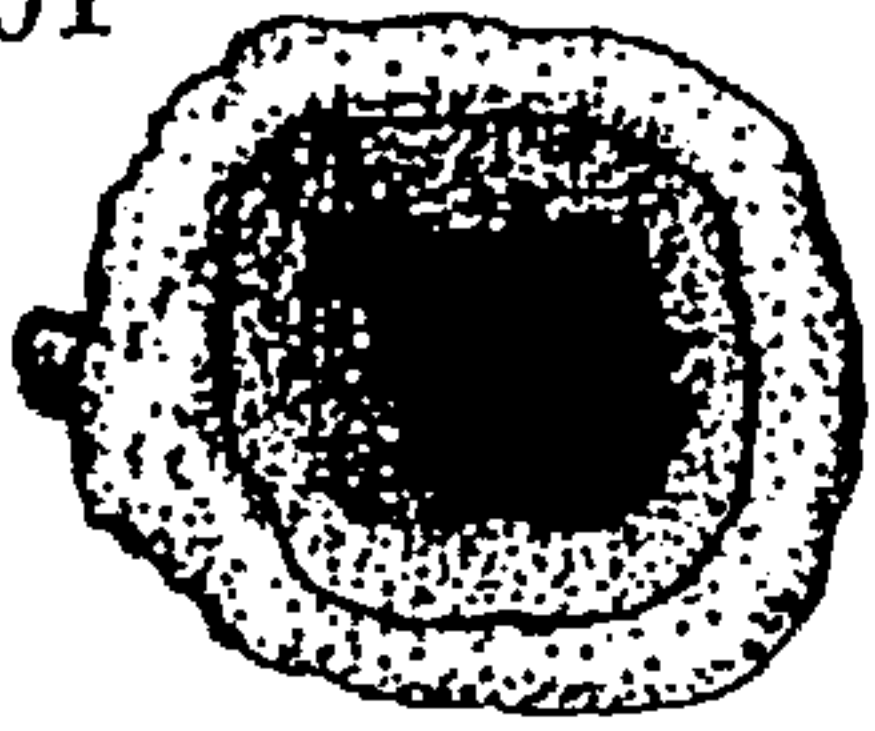
Dimensions: Length: 42mm. Width: 23mm. Thickness: 21mm. Weight: 82.5g.

20/171 (Acc. No. 93: 4-26: 151)

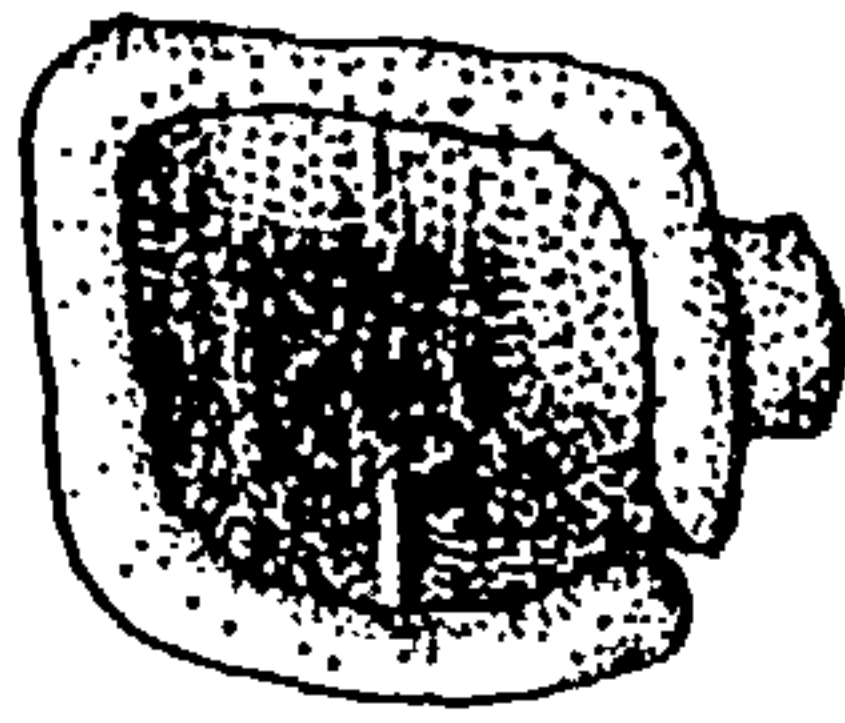
Description: Small fragment from edge of copper ingot.

Dimensions: Length: 35mm. Width: 25mm. Thickness: 25mm. Weight: 134.7g.

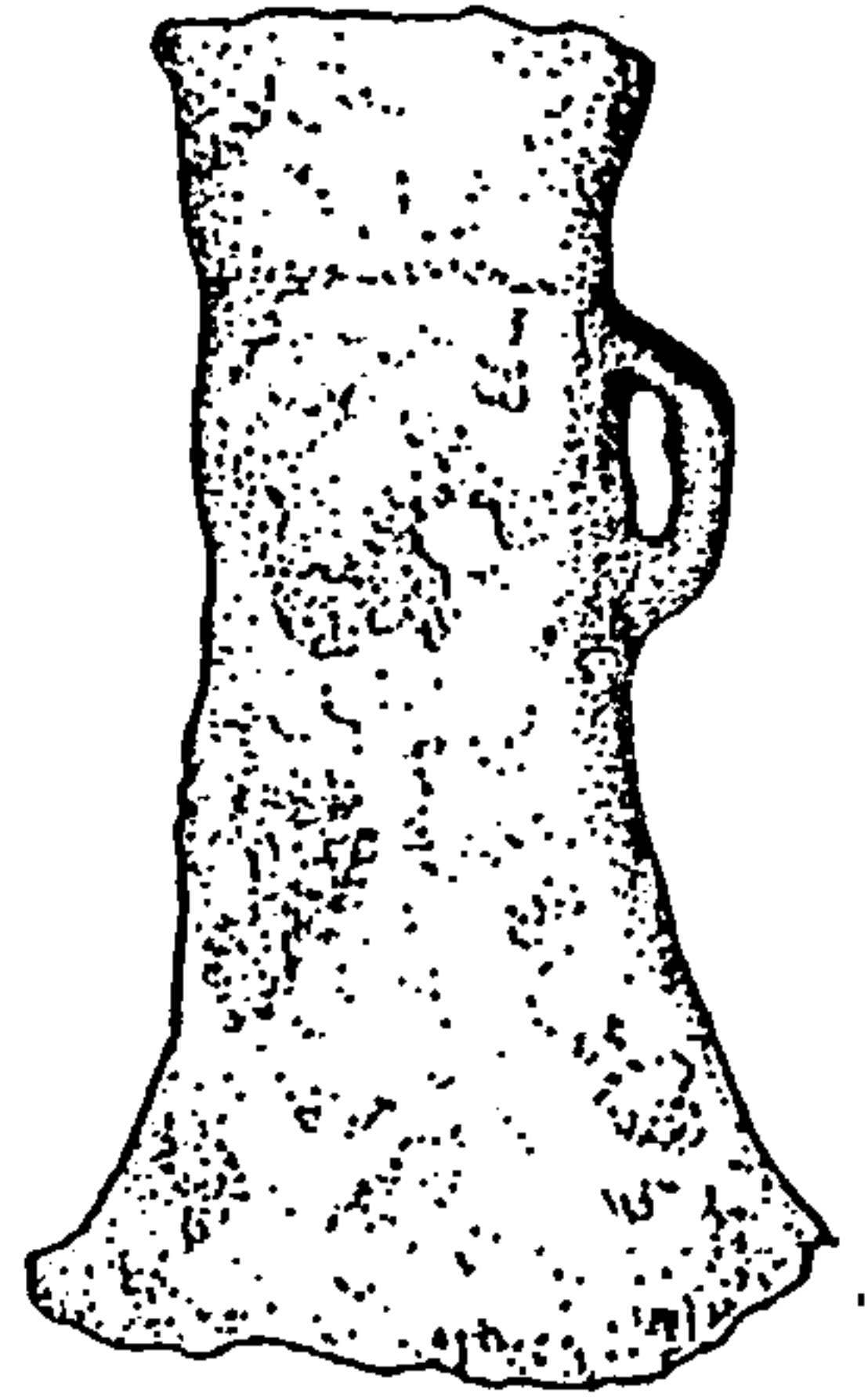
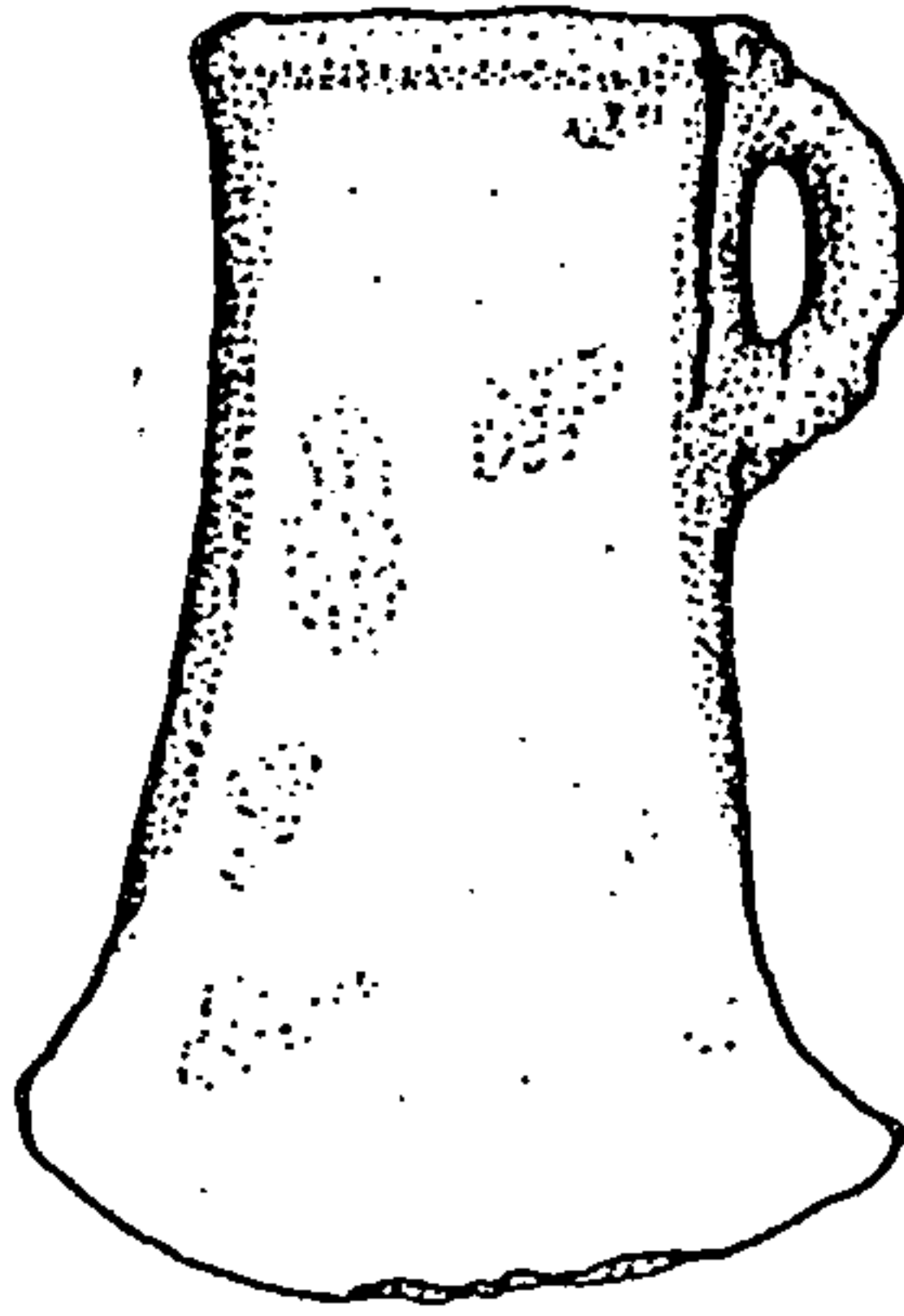
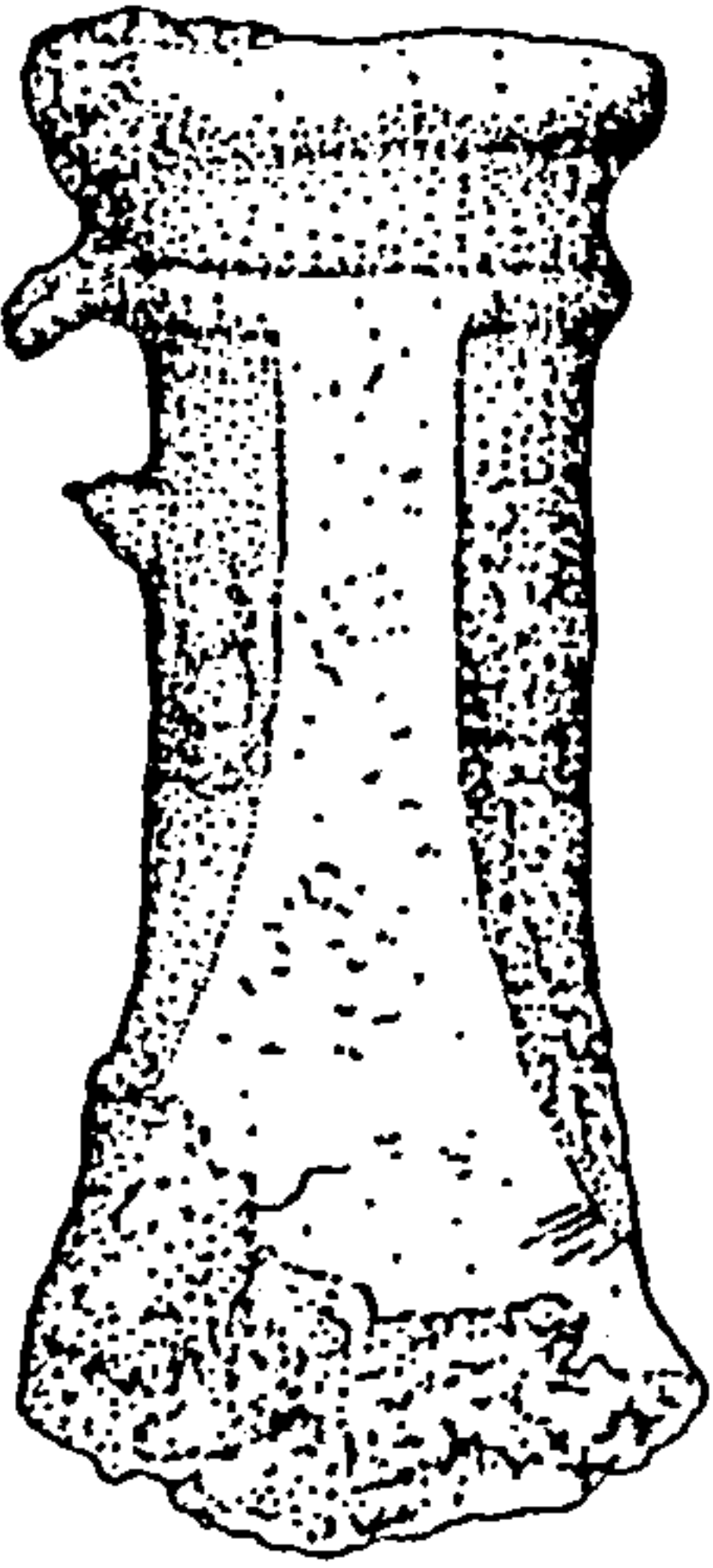
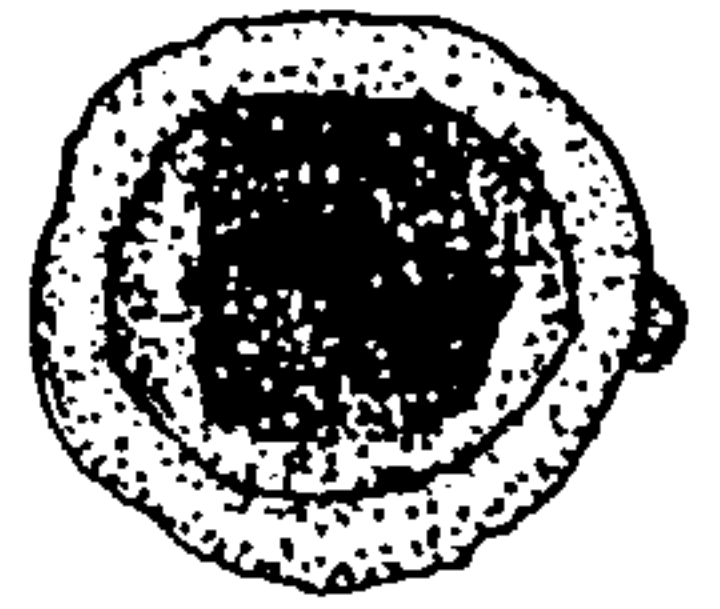
20/01



20/02

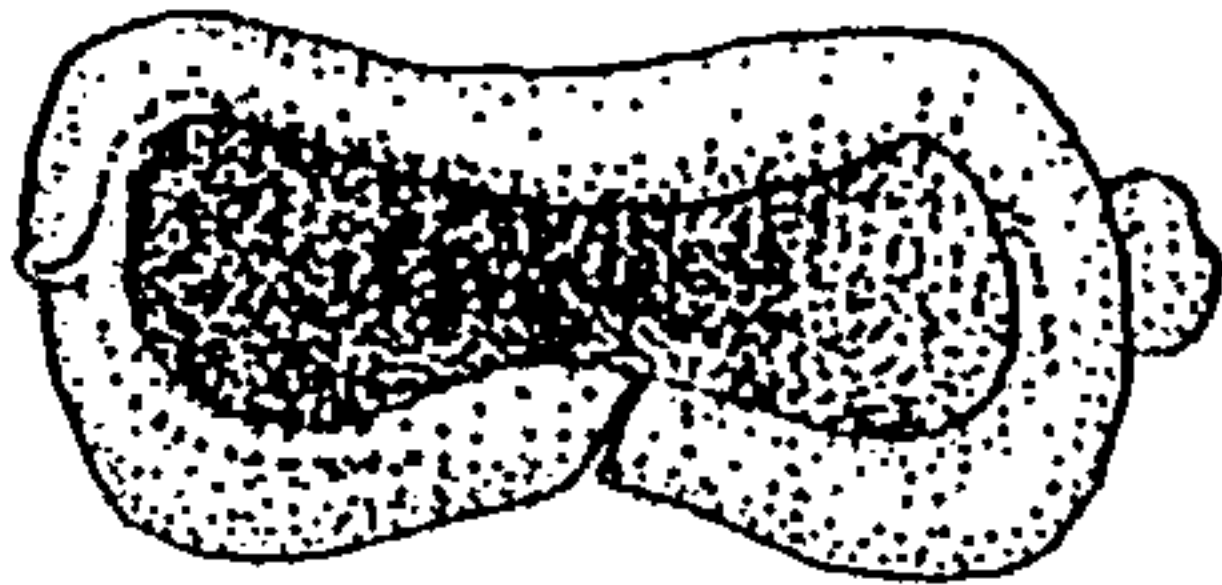


20/03



0 2cm

20/04



20/05

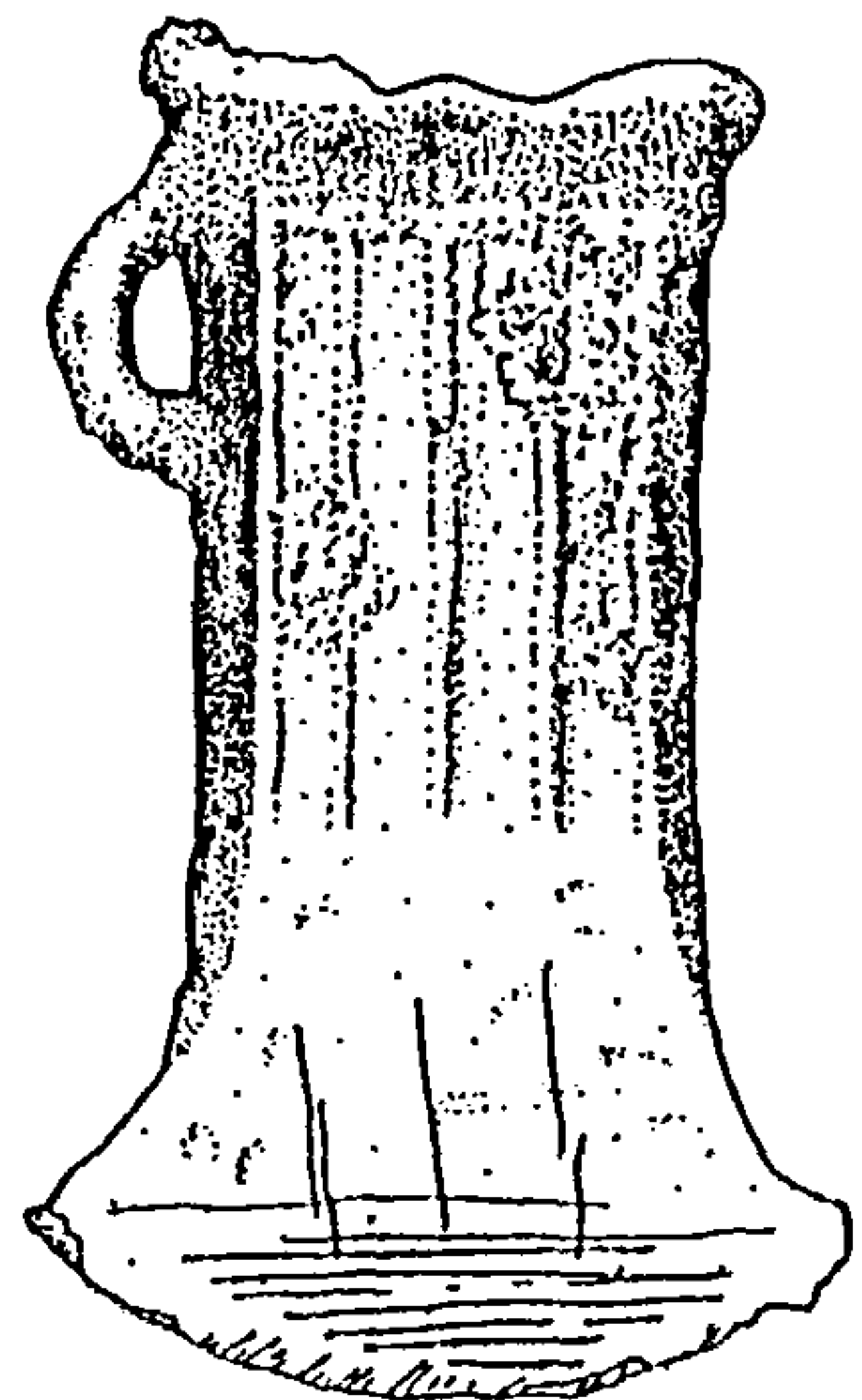
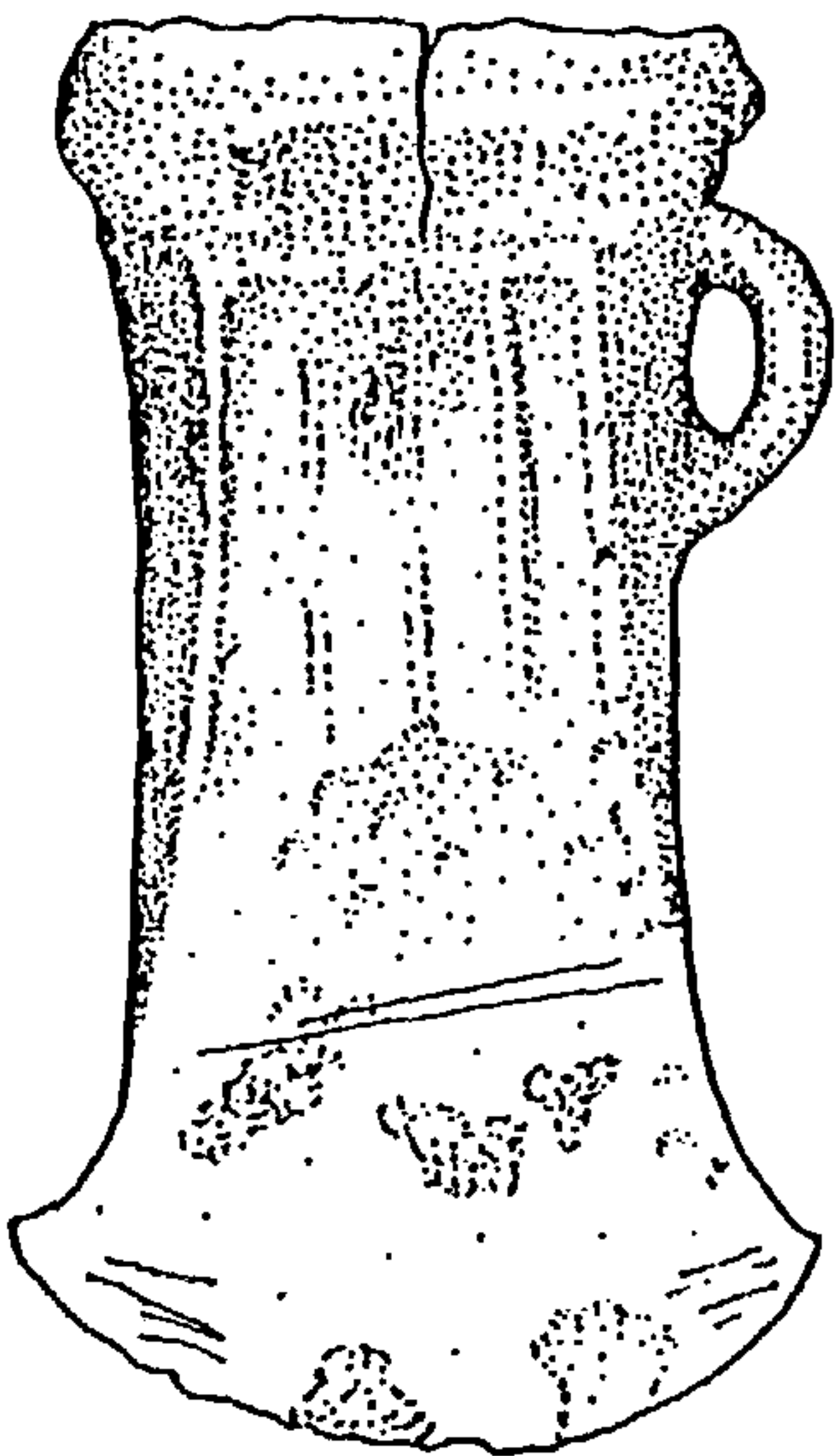
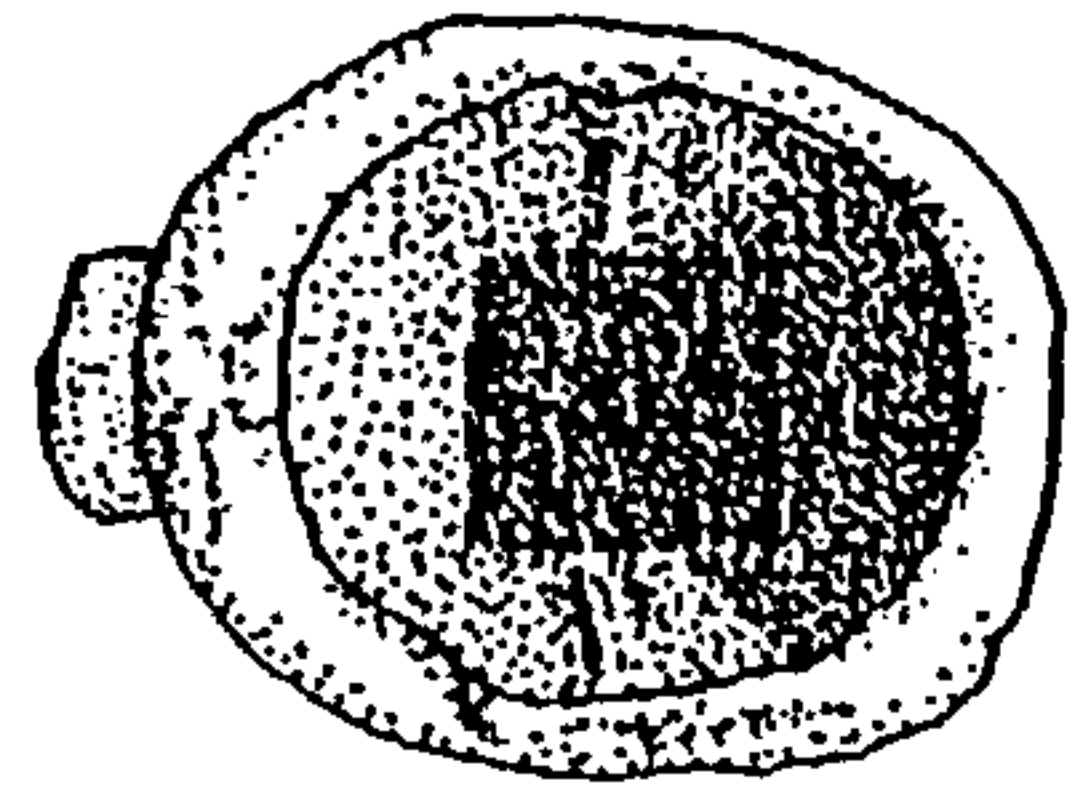
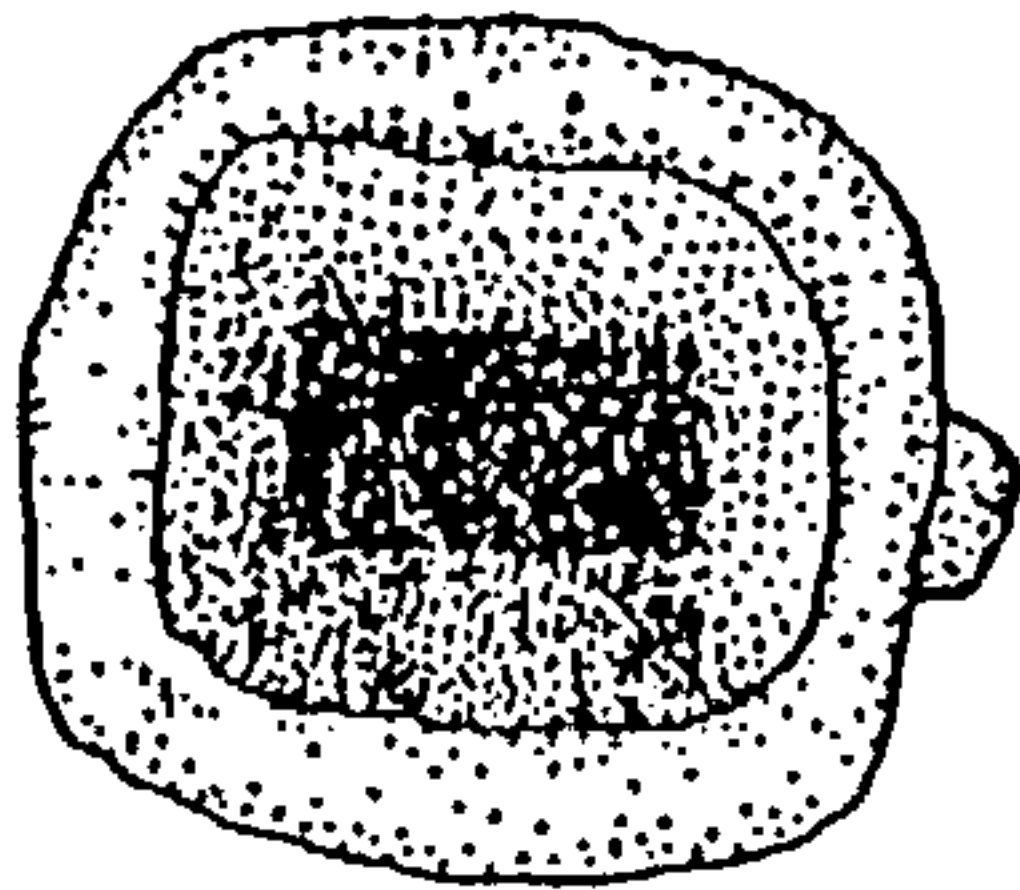
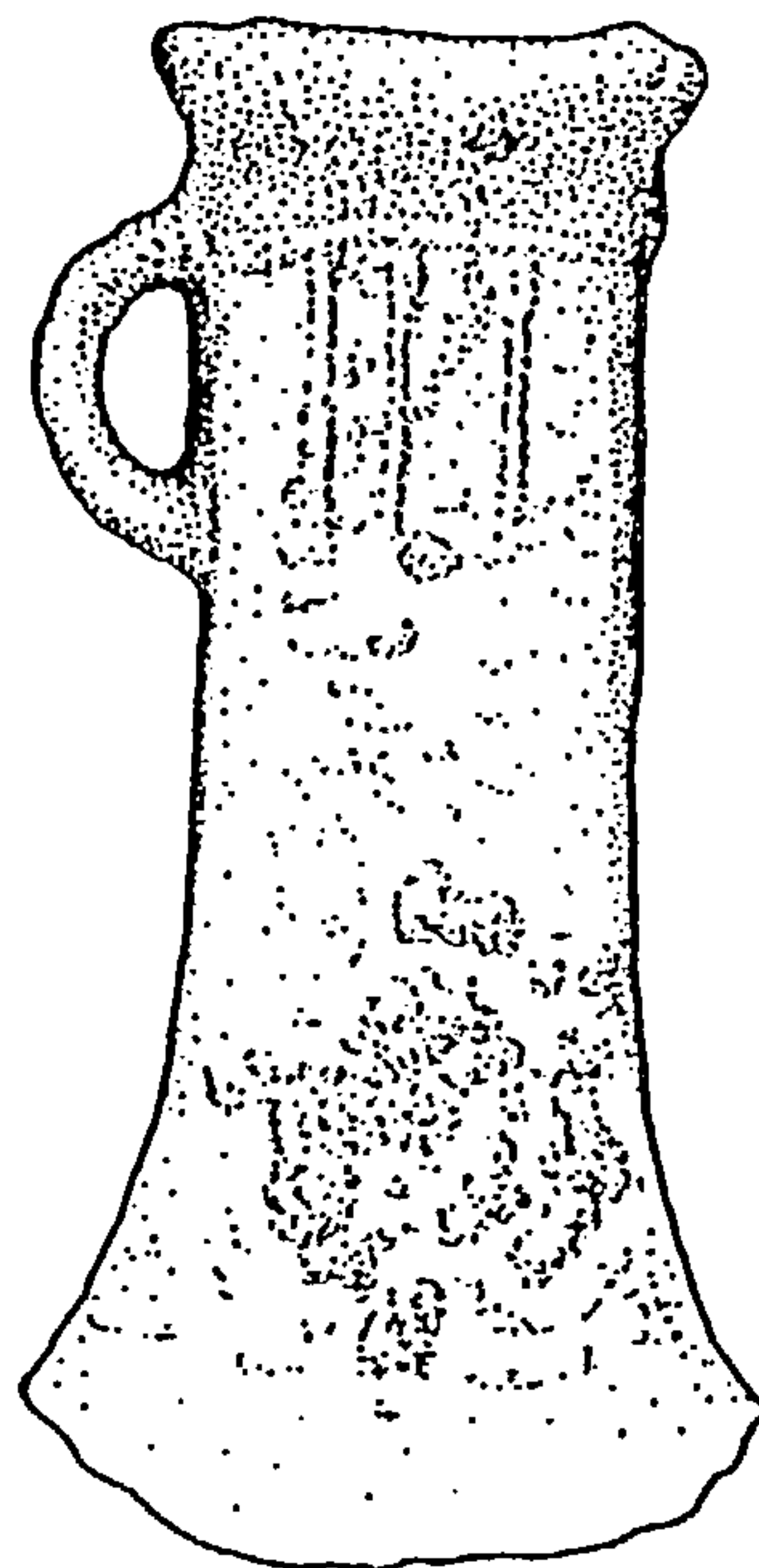
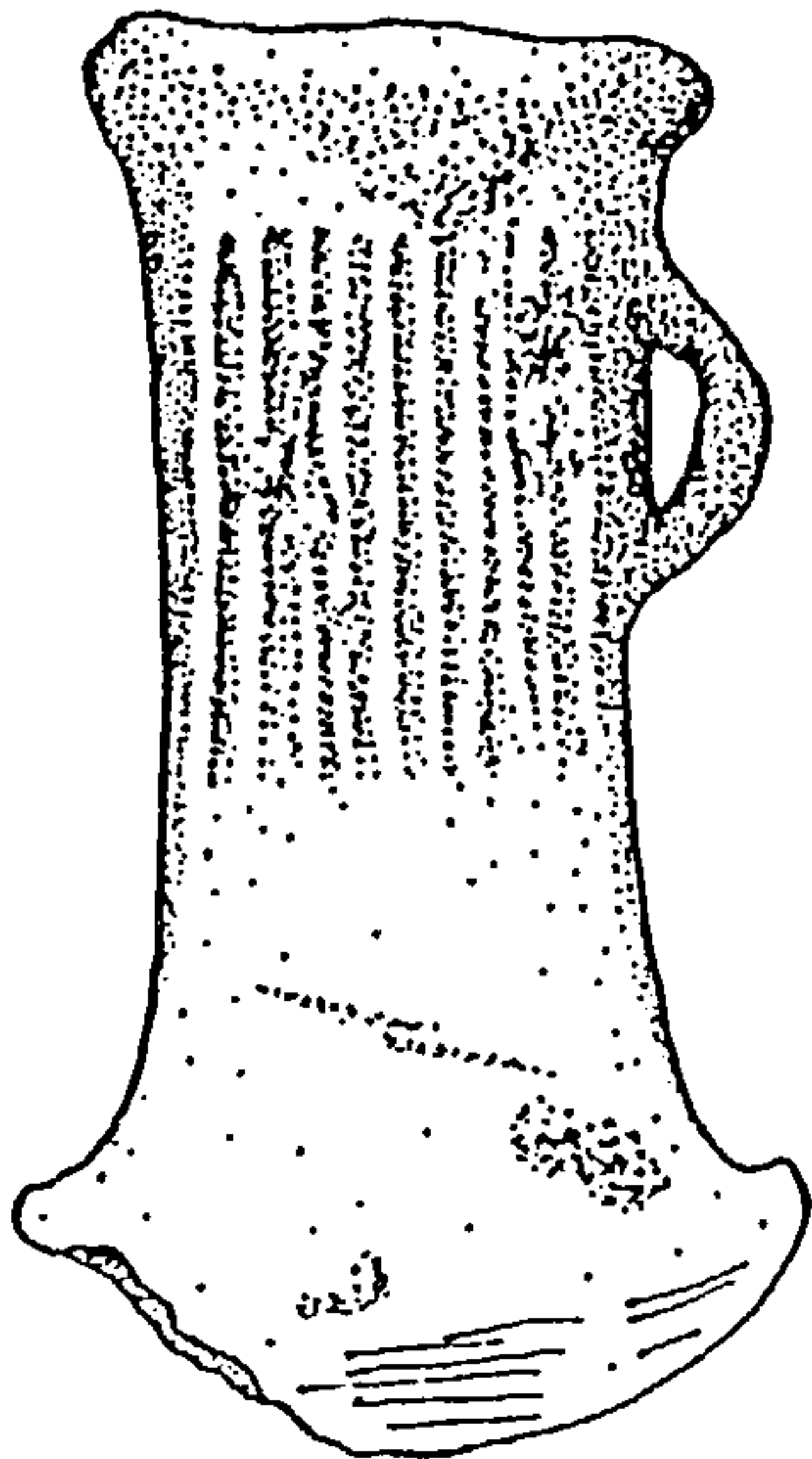
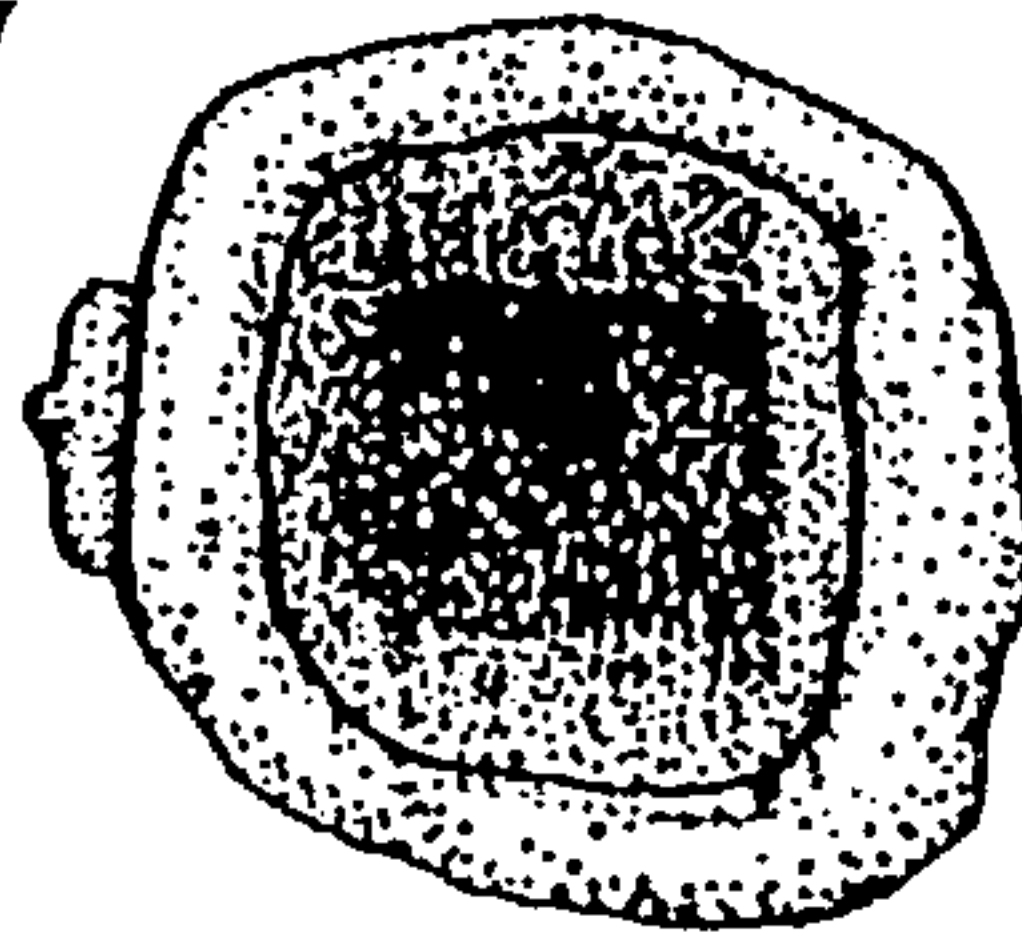


Fig. 53: The Minster Hoard (Ref. No. 20): Complete Socketed Axes (i)

20/06

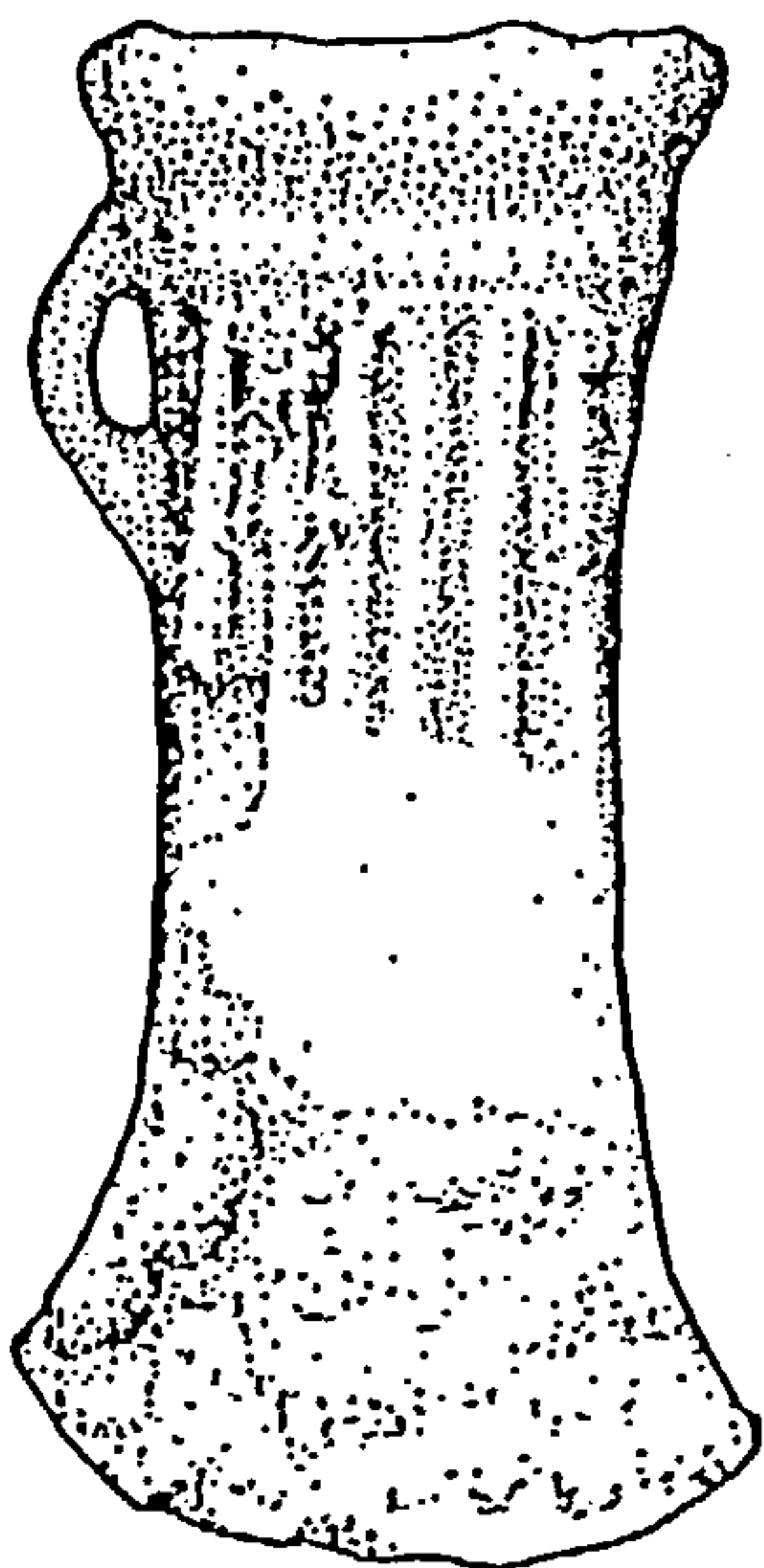


20/07

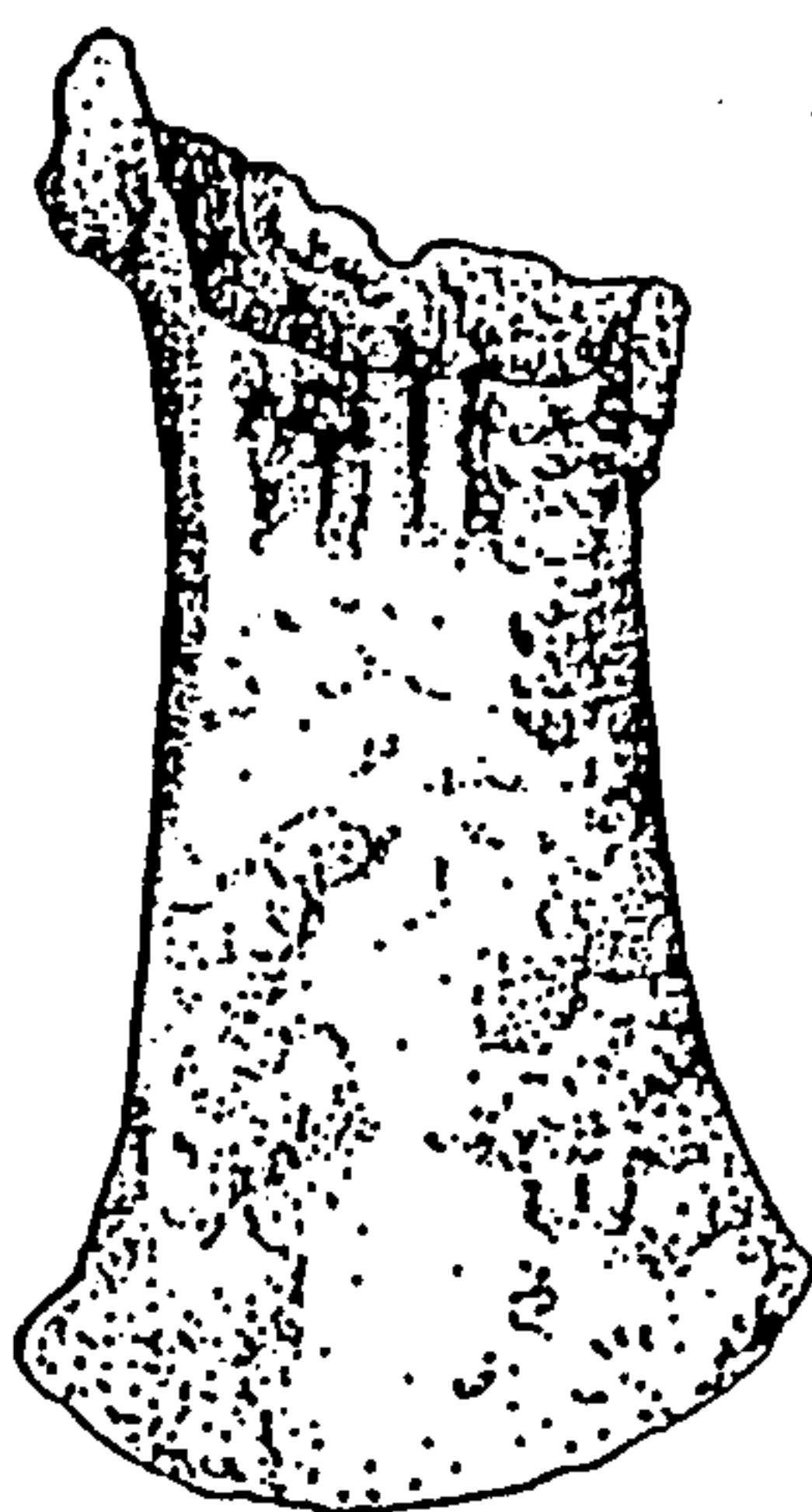


0 2cm

20/08



20/09



20/10

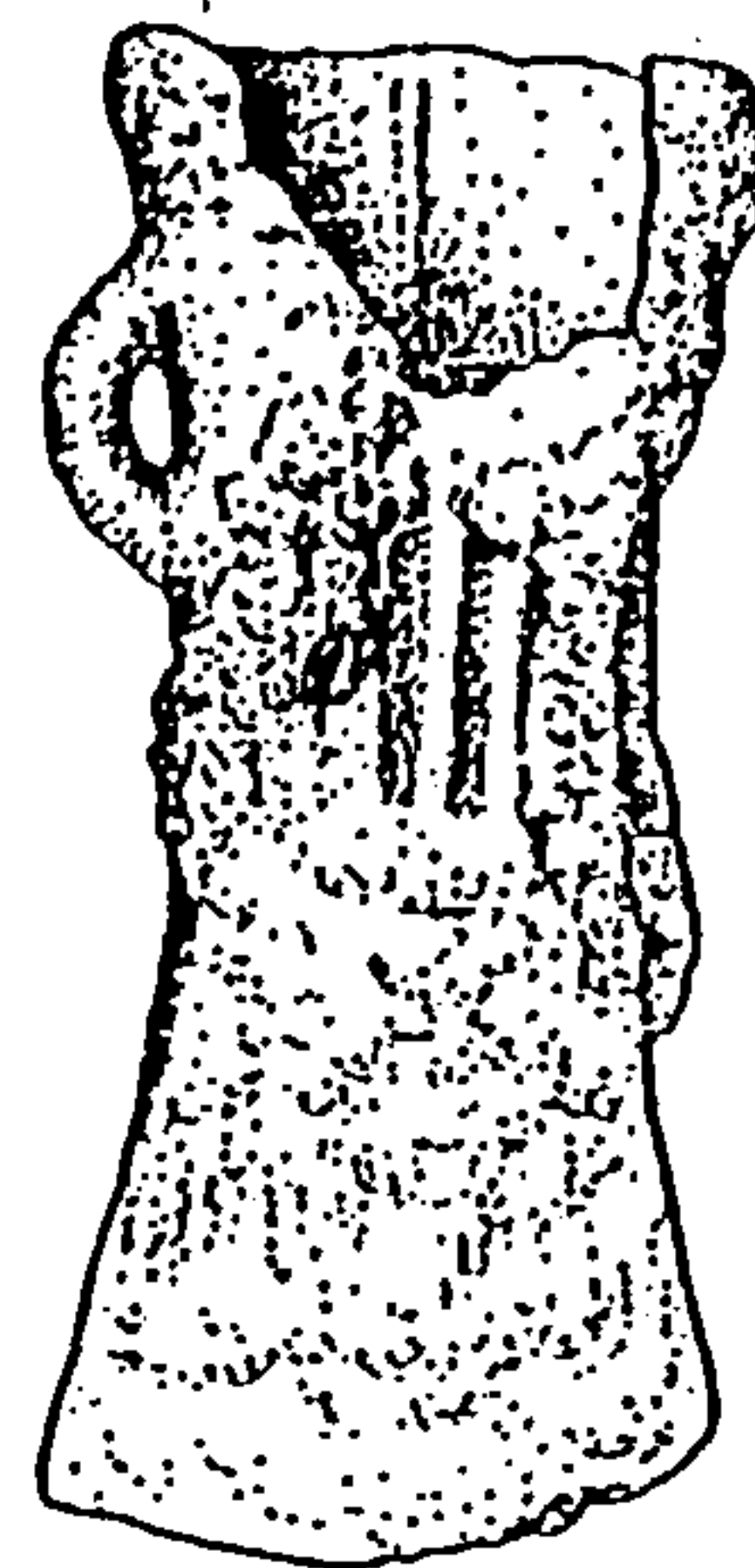
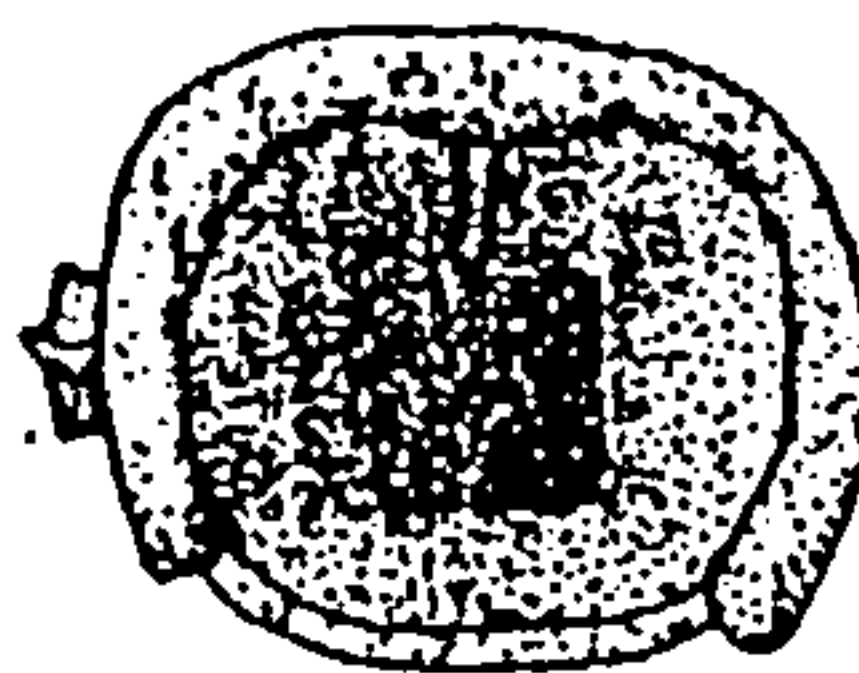
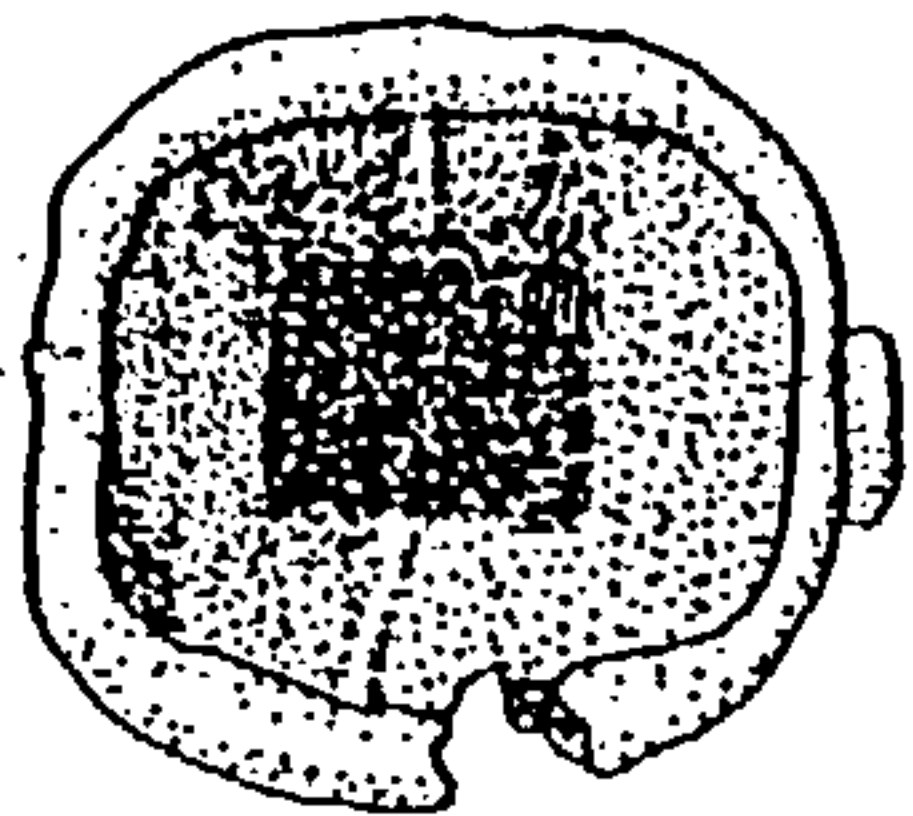
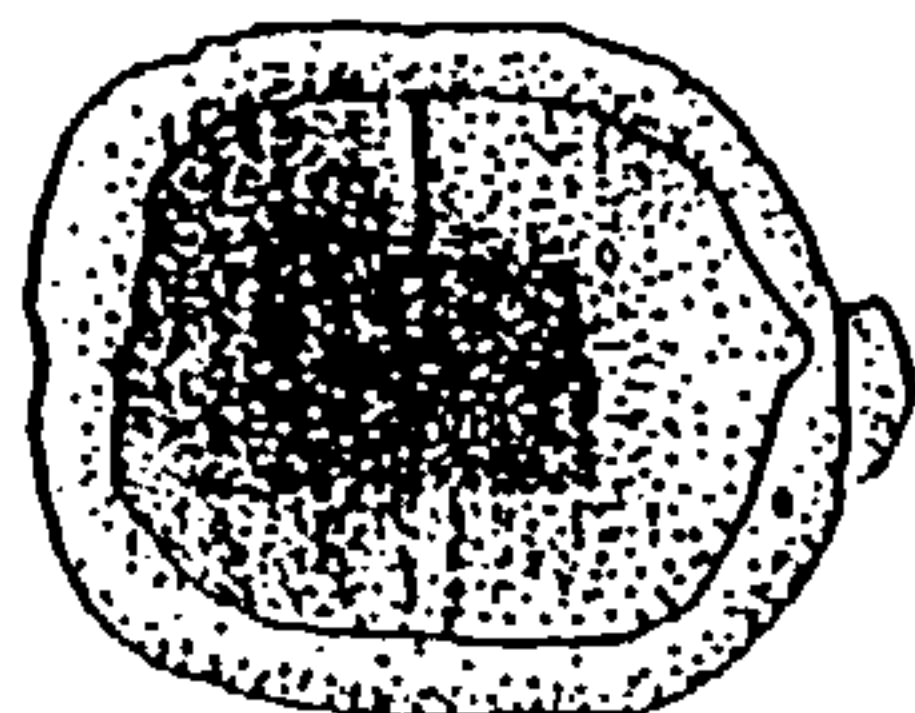


Fig. 54: The Minster Hoard (Ref. No. 20): Complete Socketed Axes (ii)

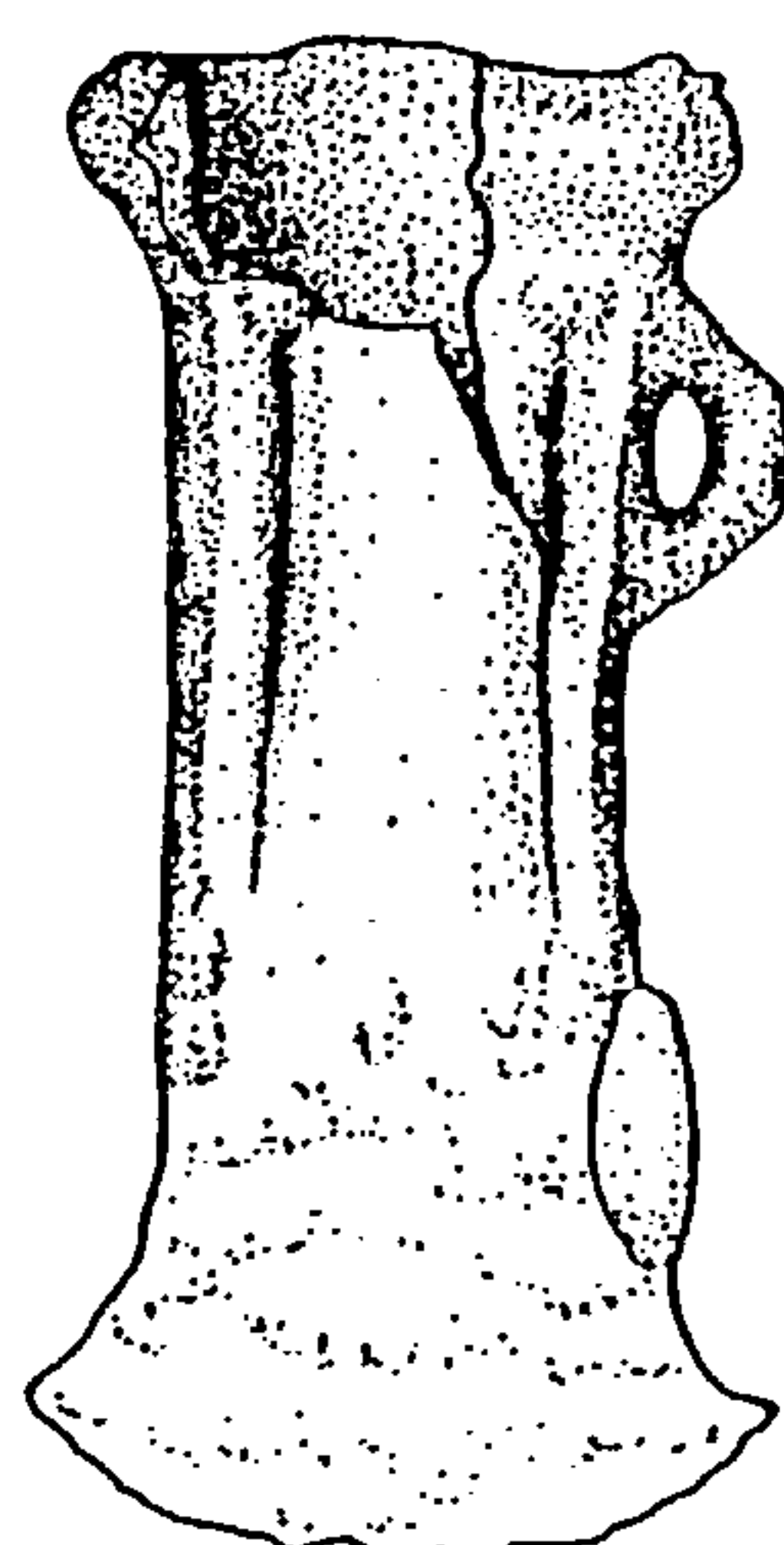
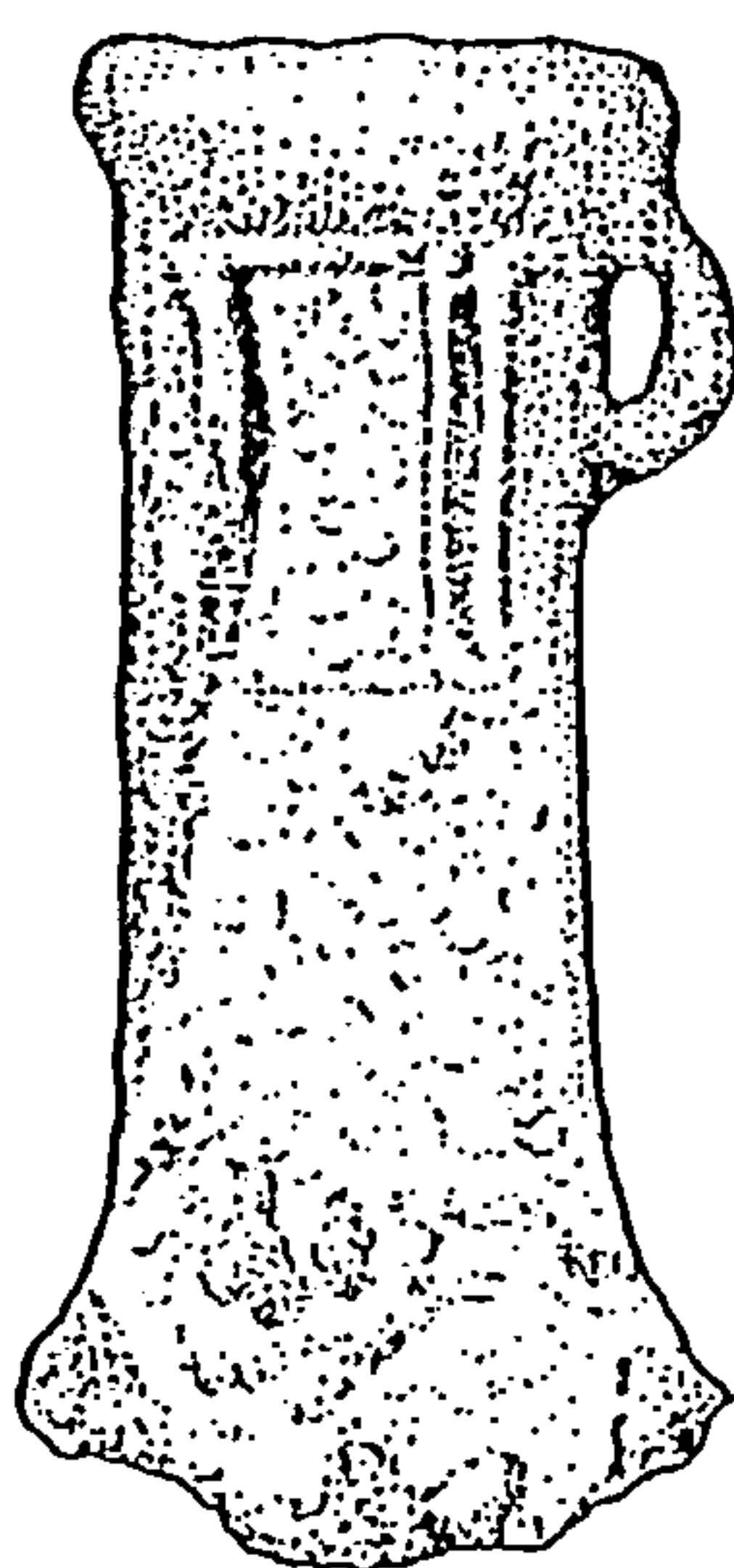
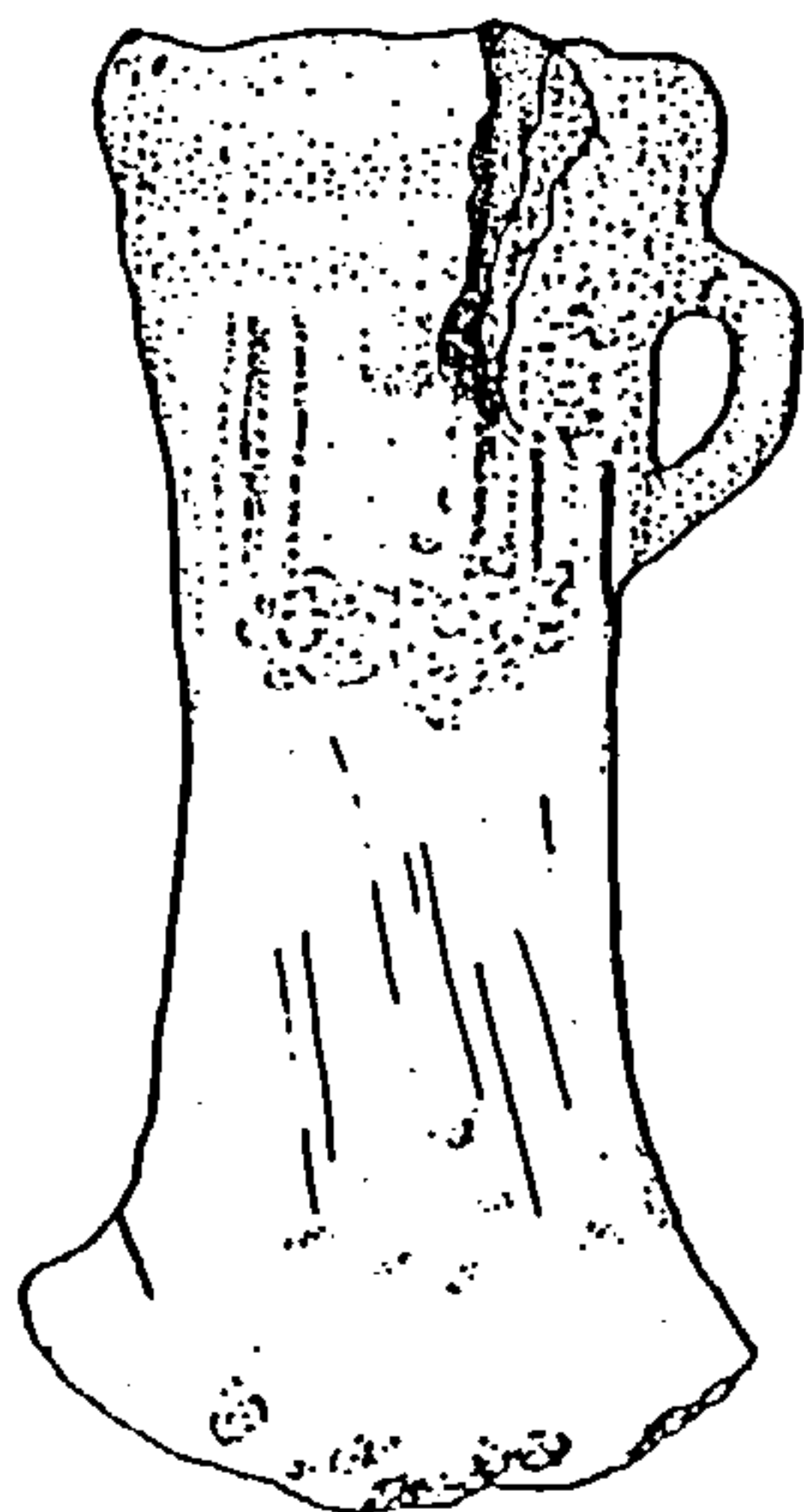
20/11



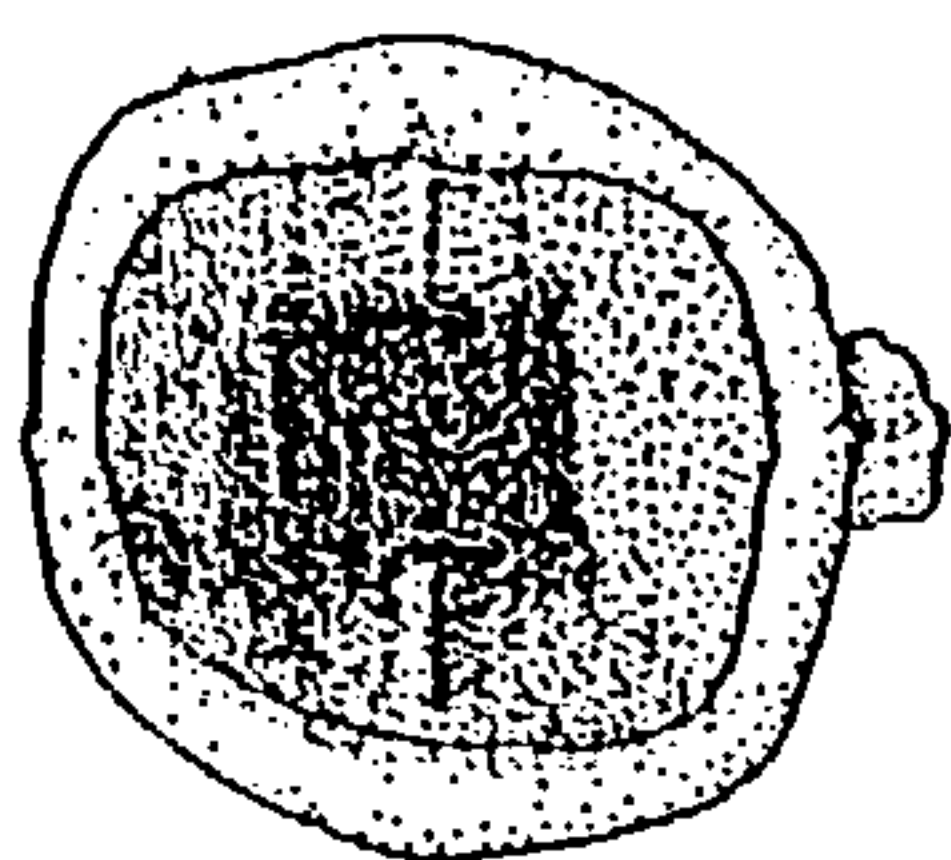
20/12



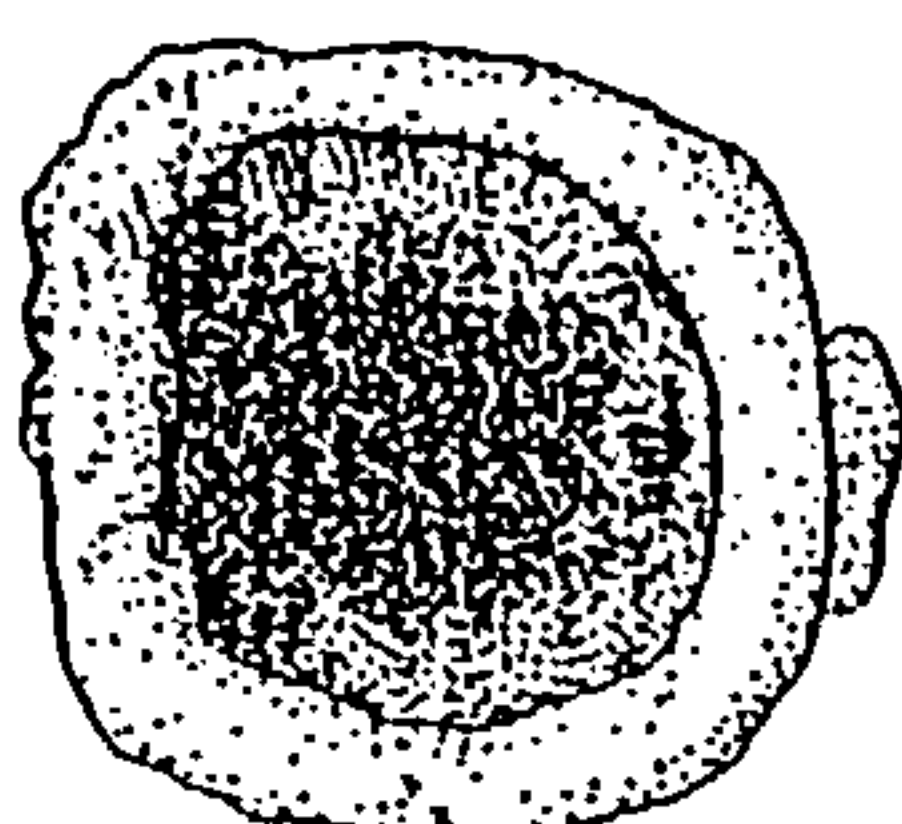
20/13



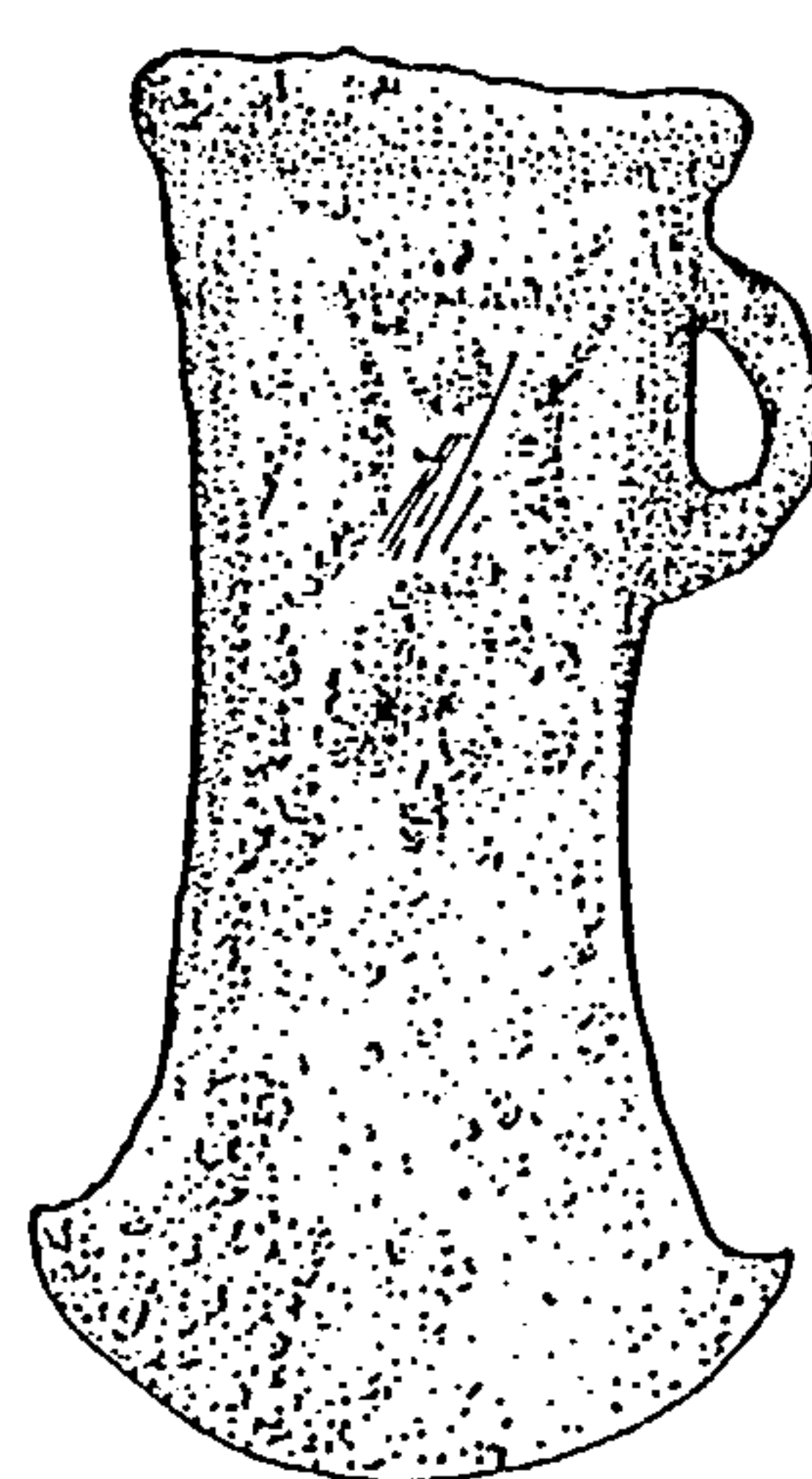
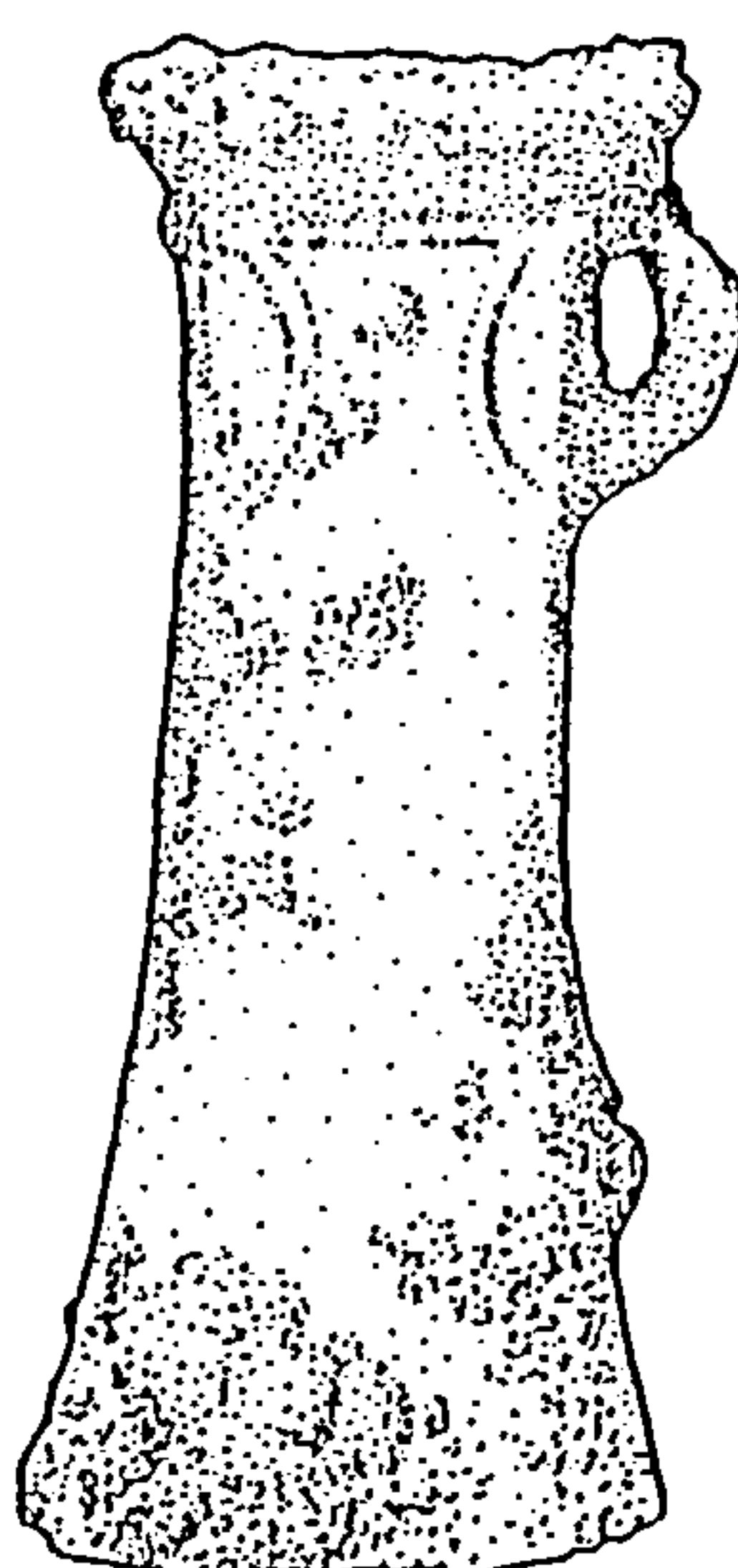
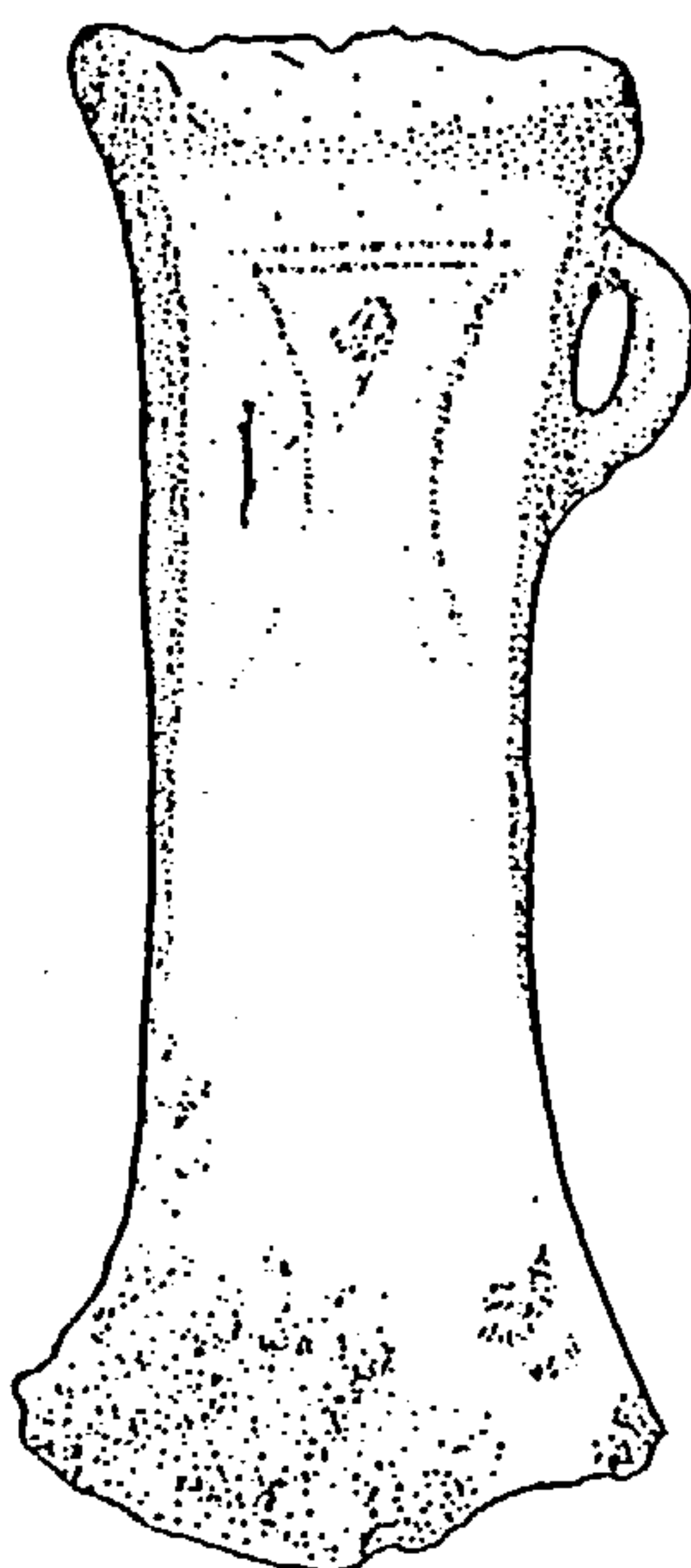
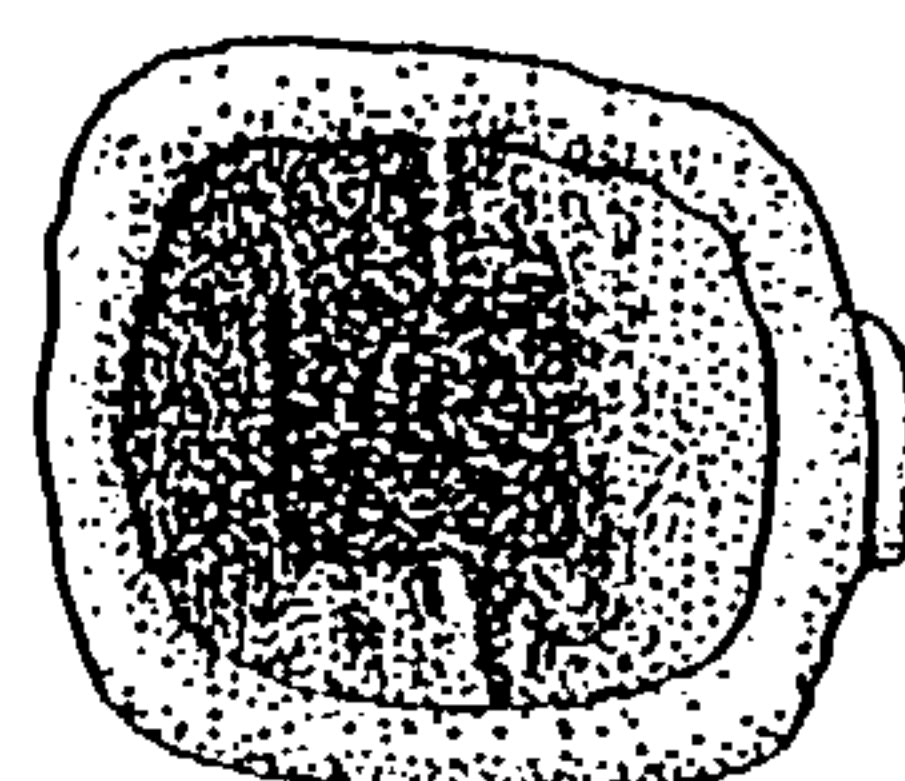
20/14



20/15



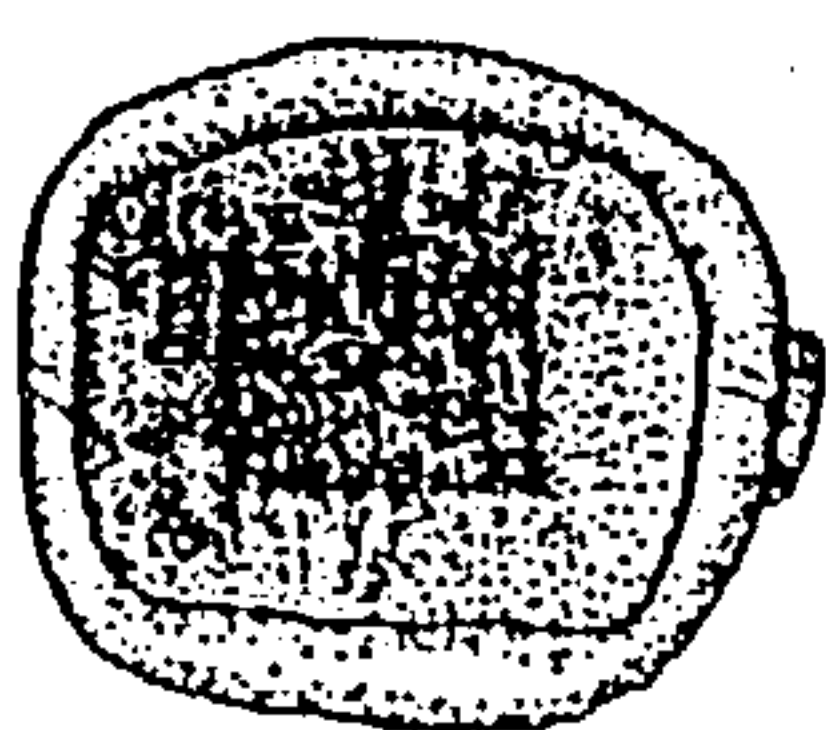
20/16



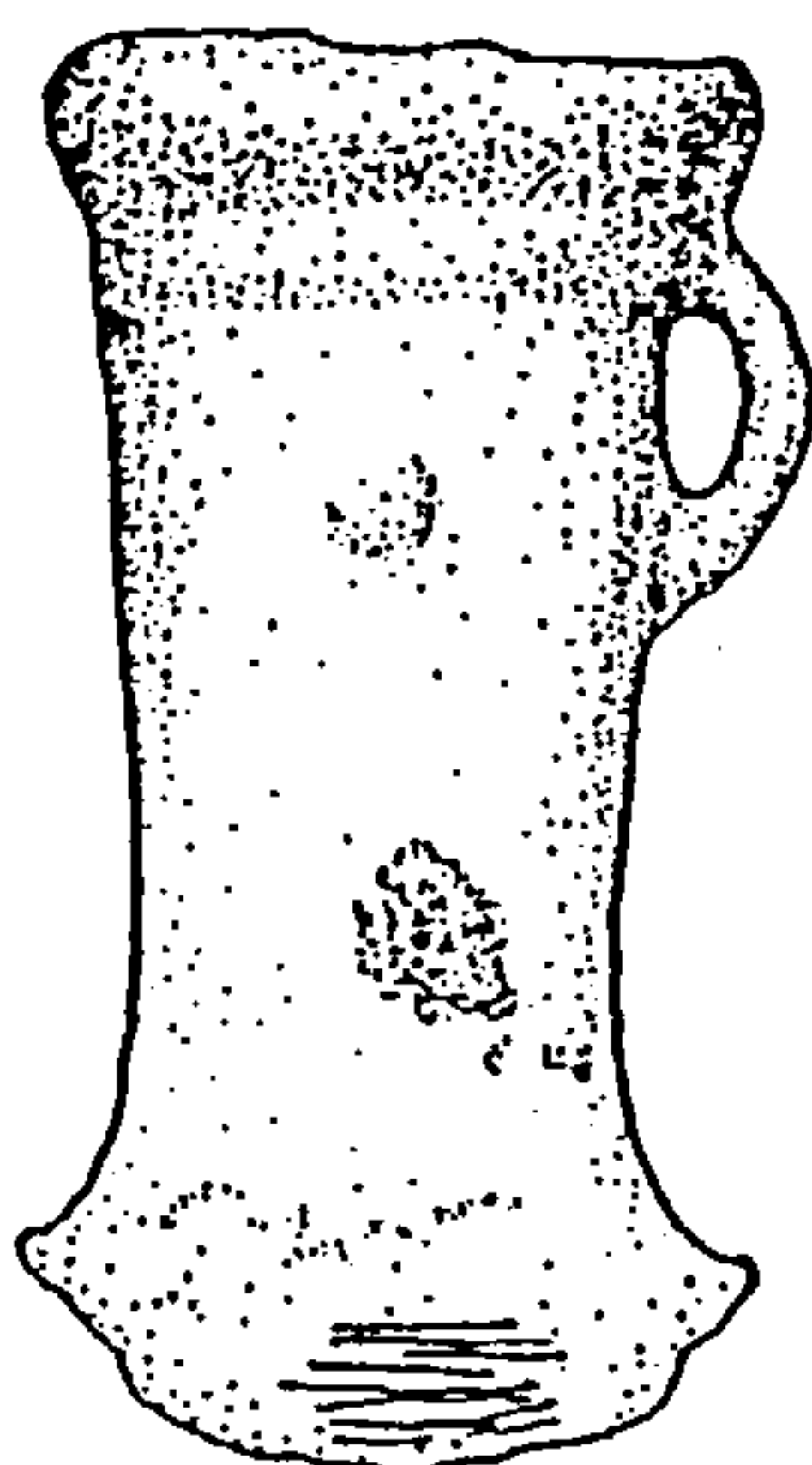
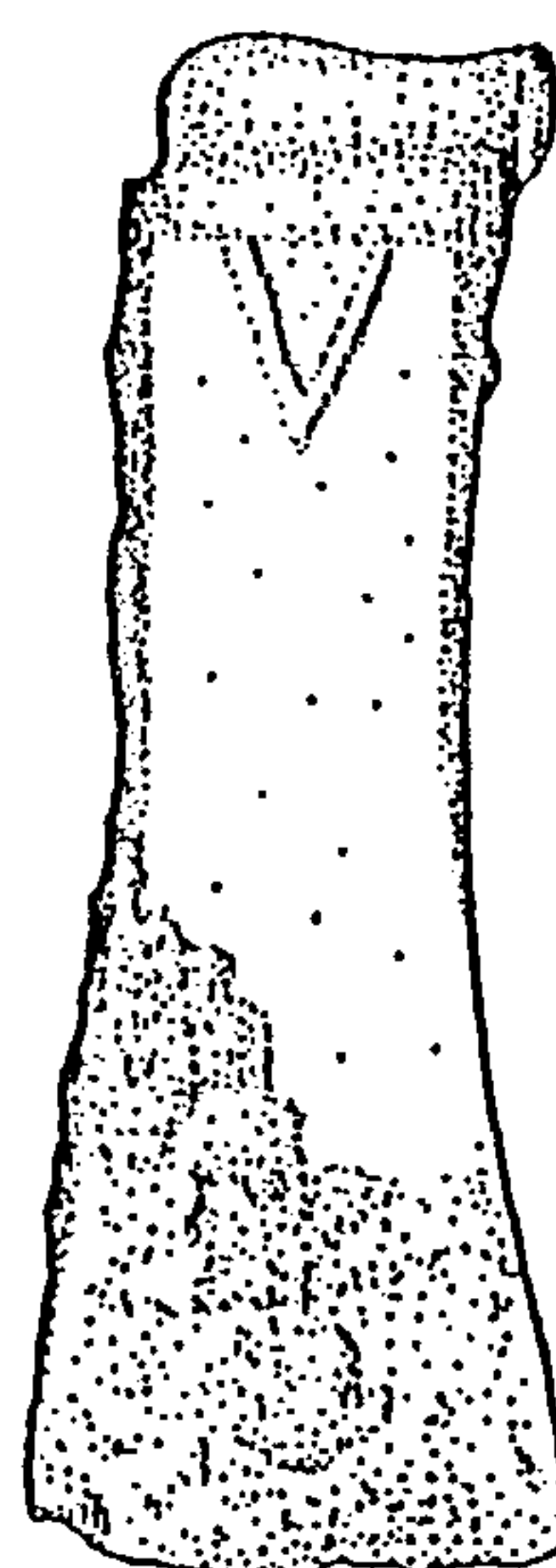
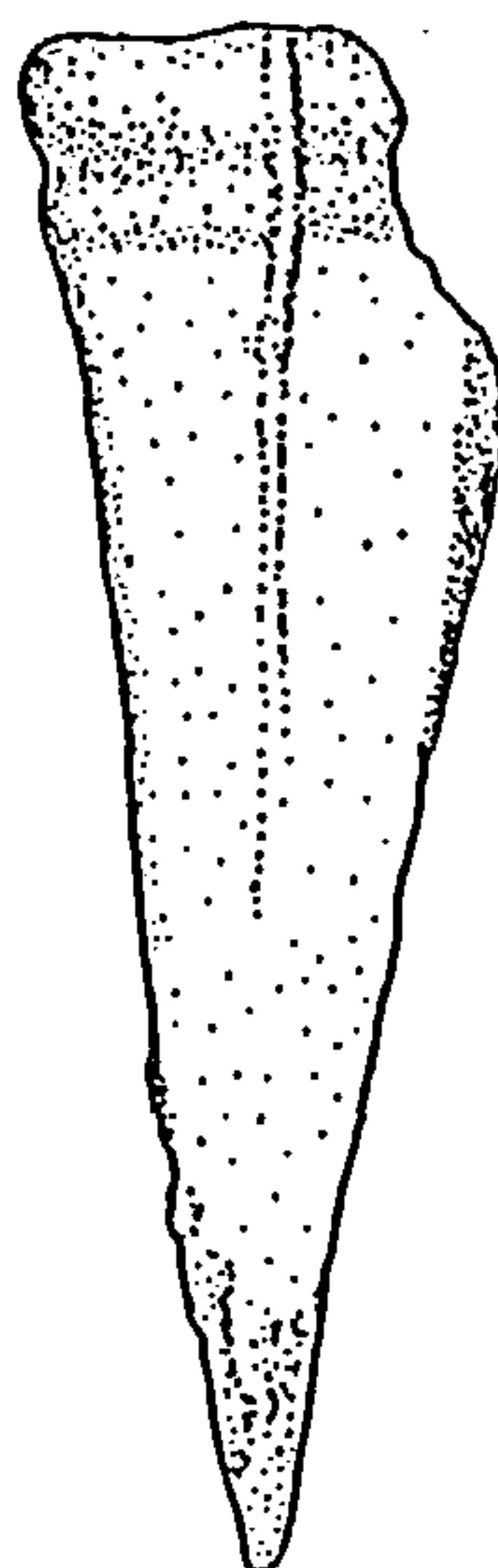
0 2cm

Fig. 55: The Minster Hoard (Ref. No. 20): Complete Socketed Axes (iii)

20/17

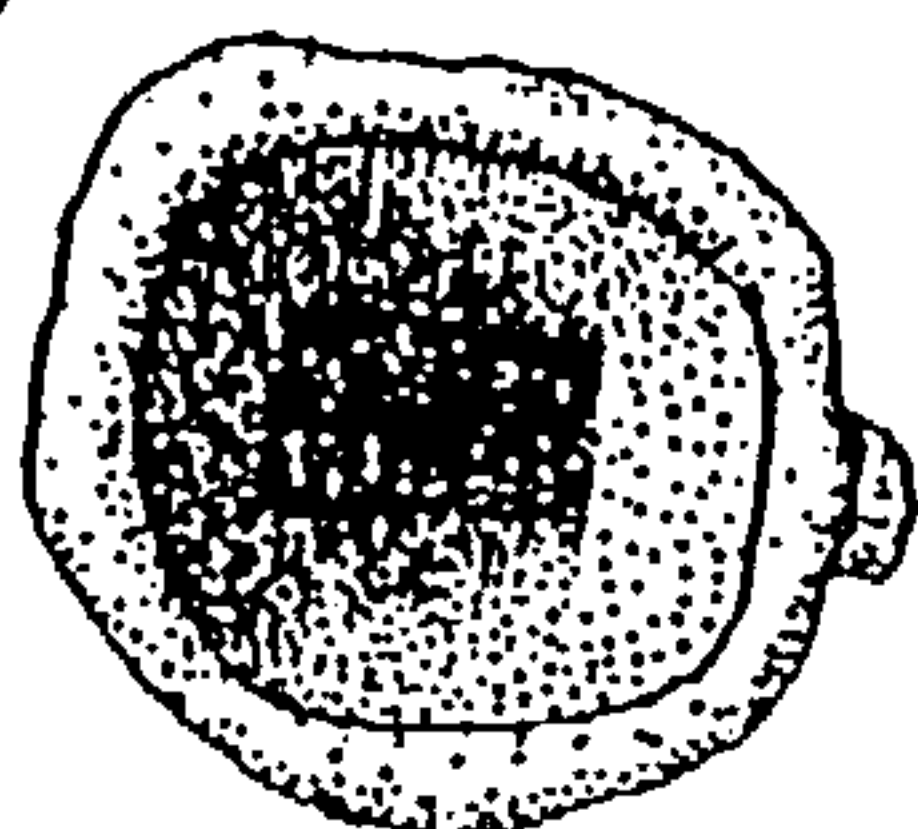


20/18

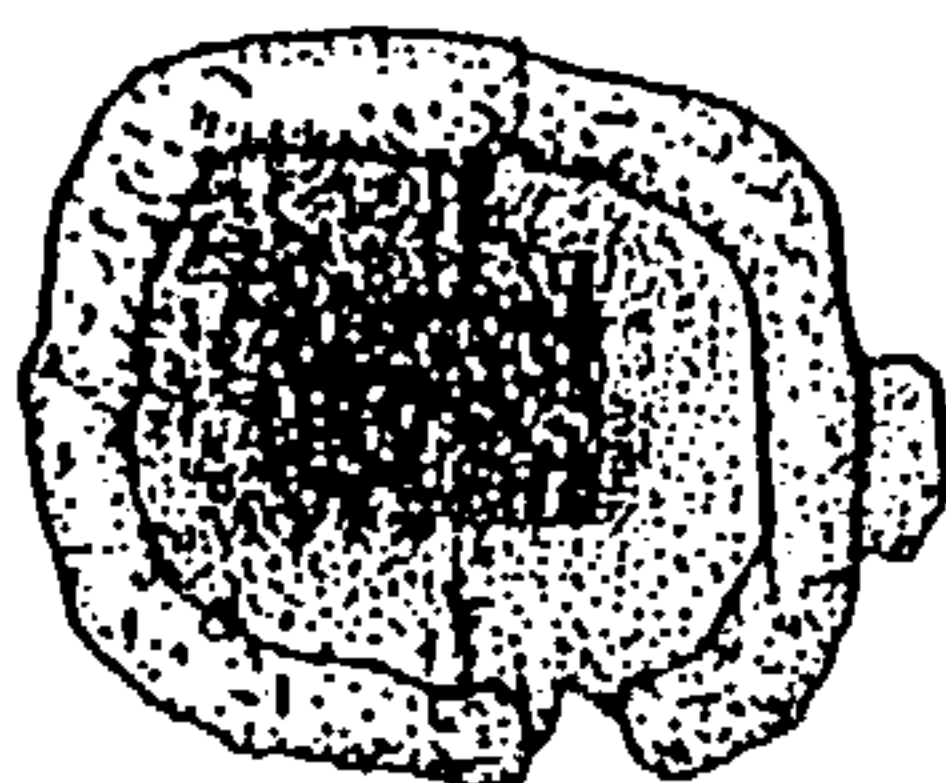


0 2cm

20/19



20/20



20/21

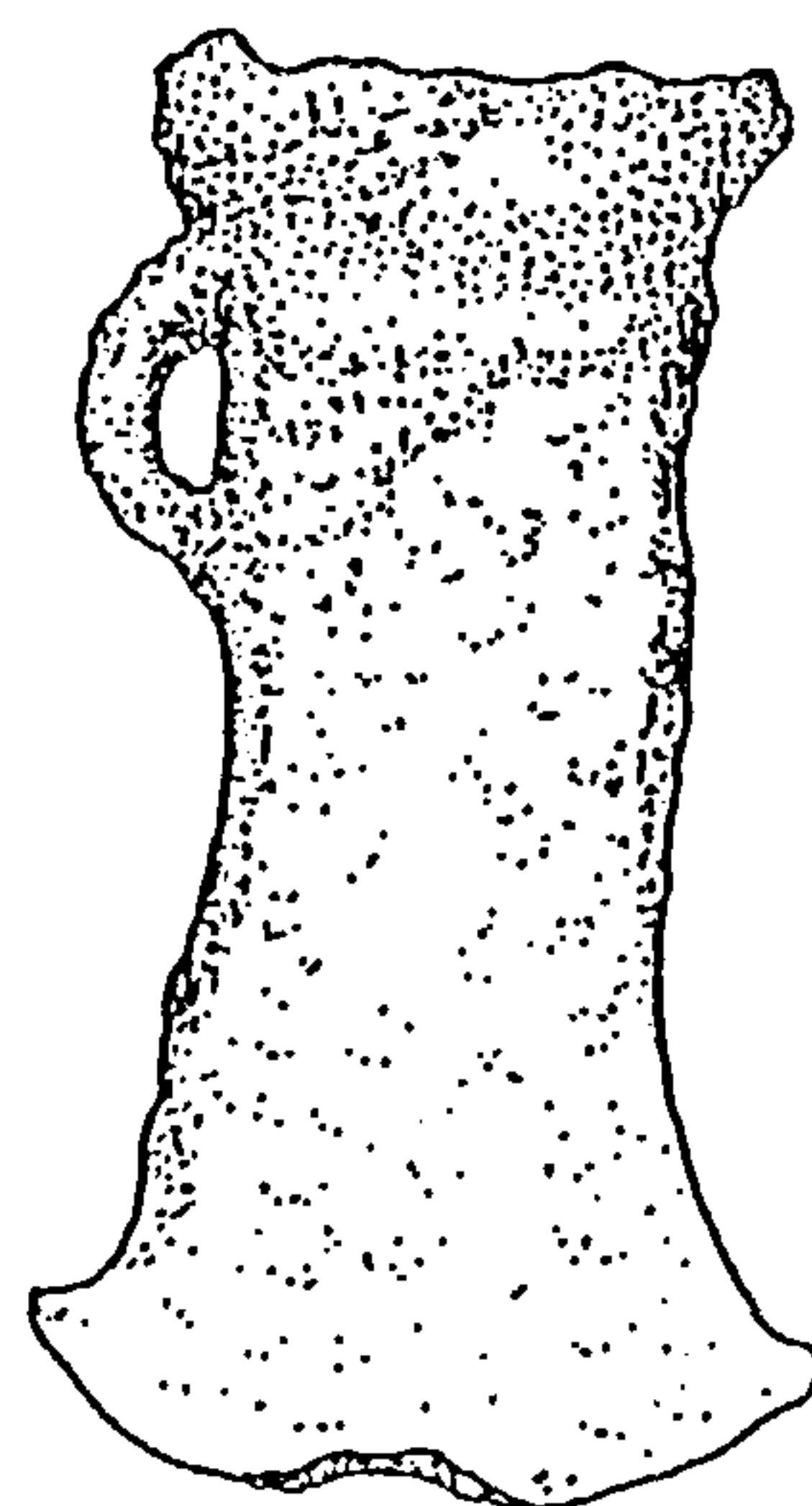
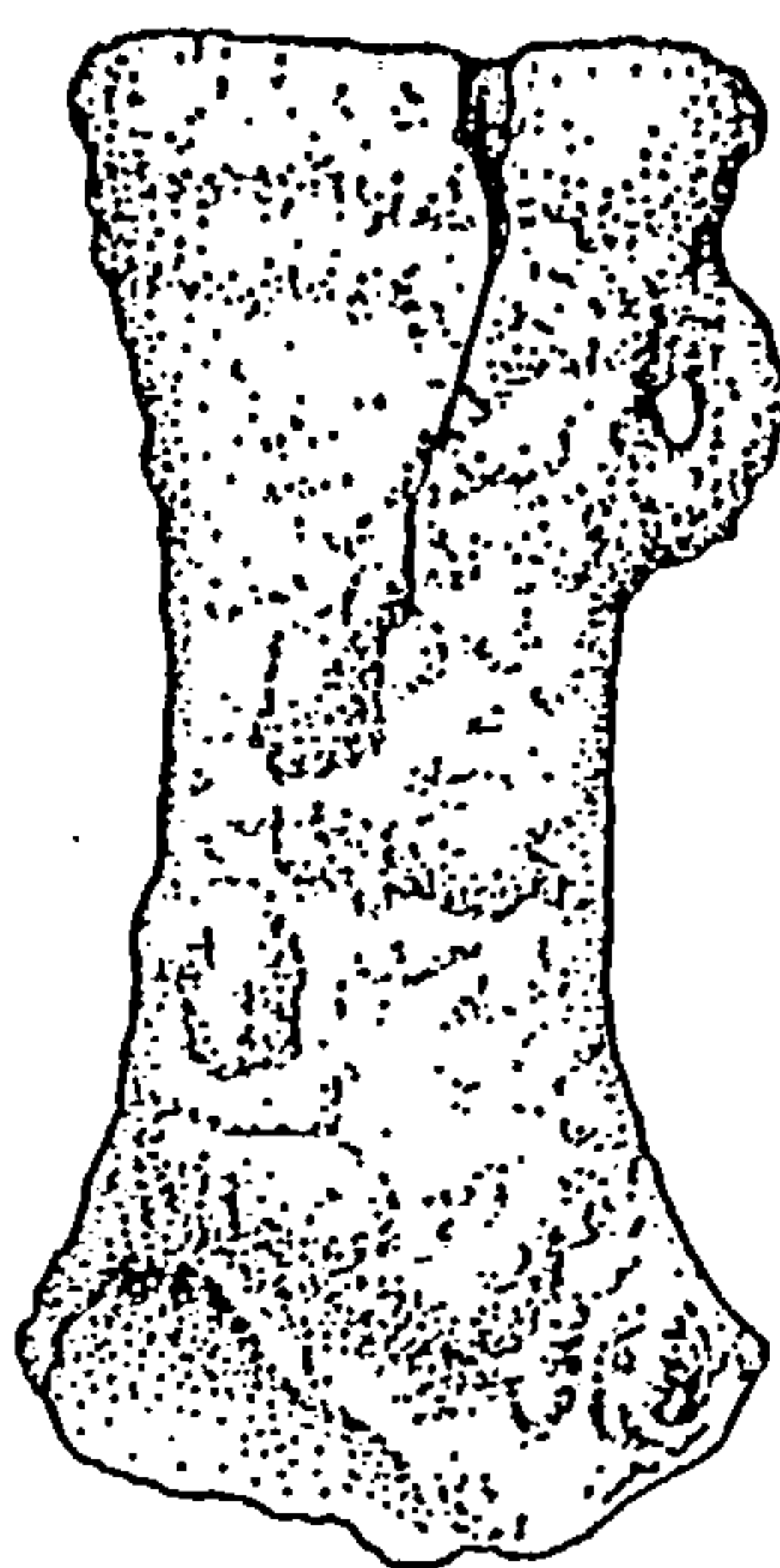
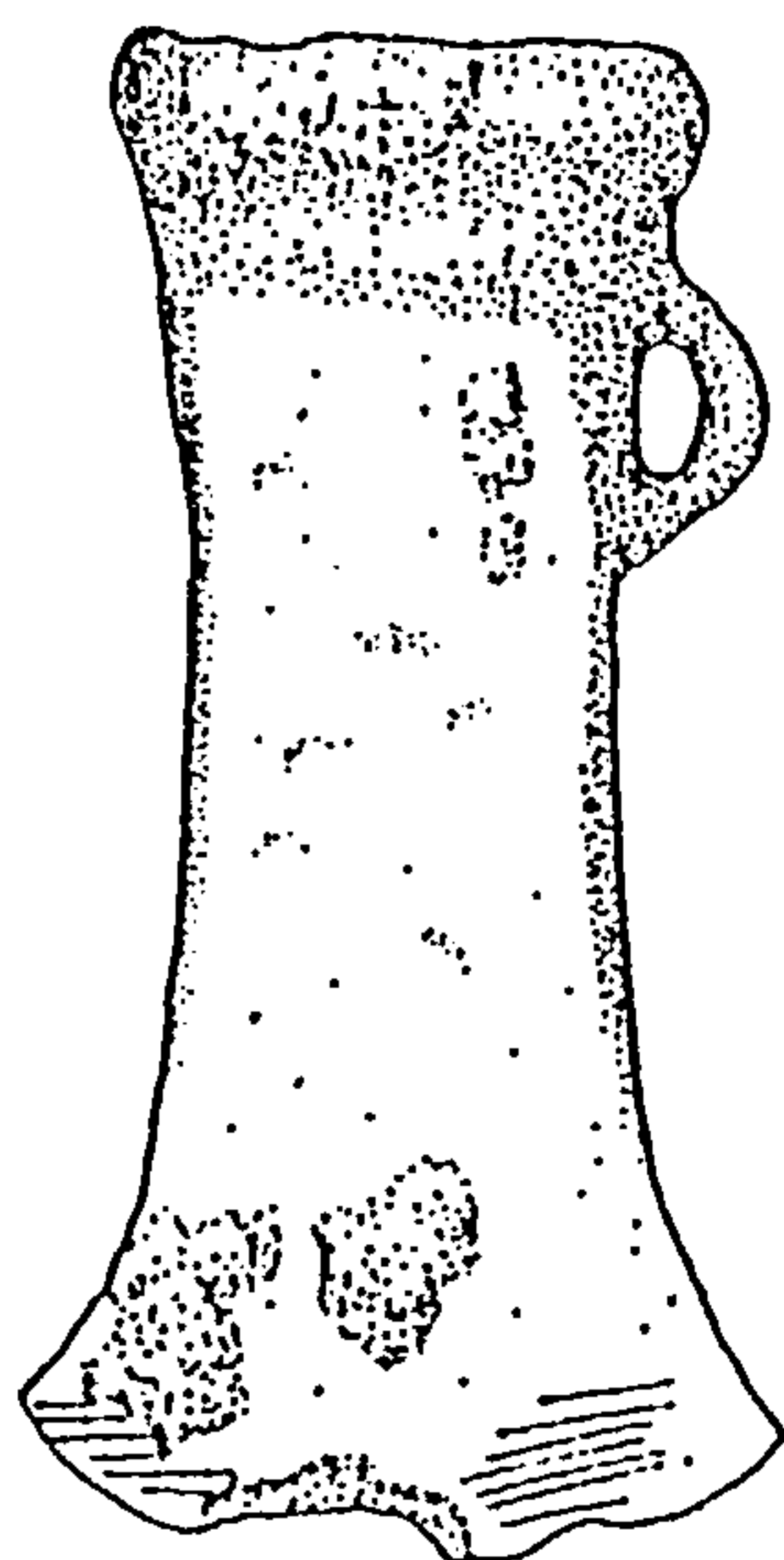
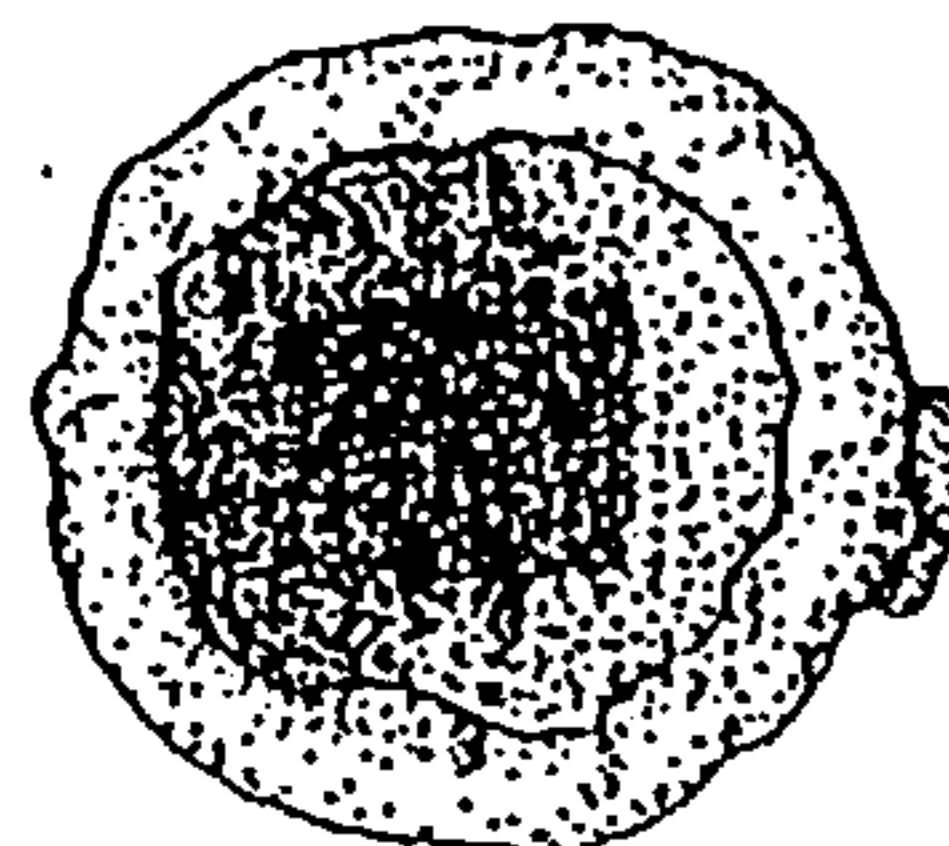
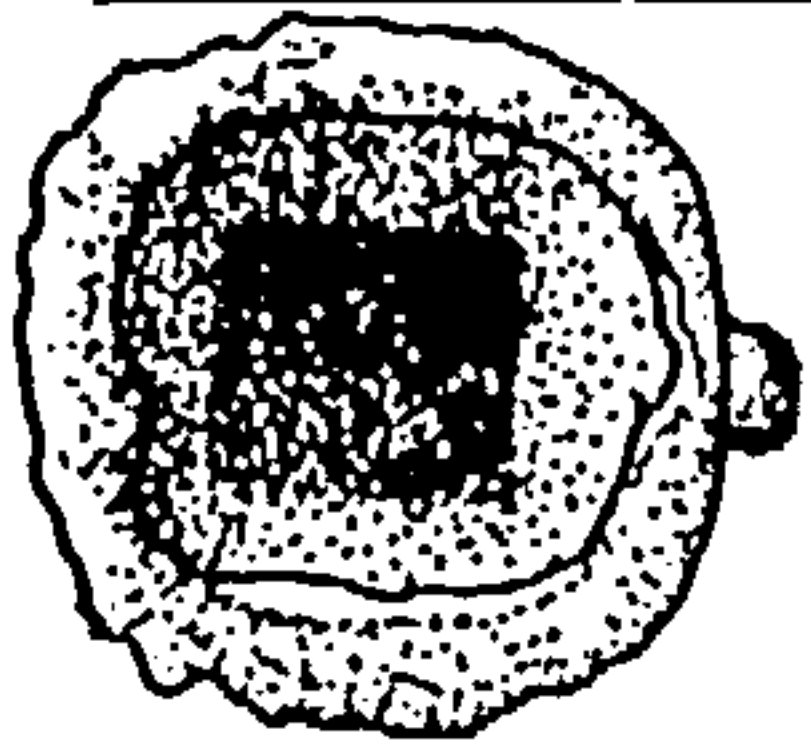
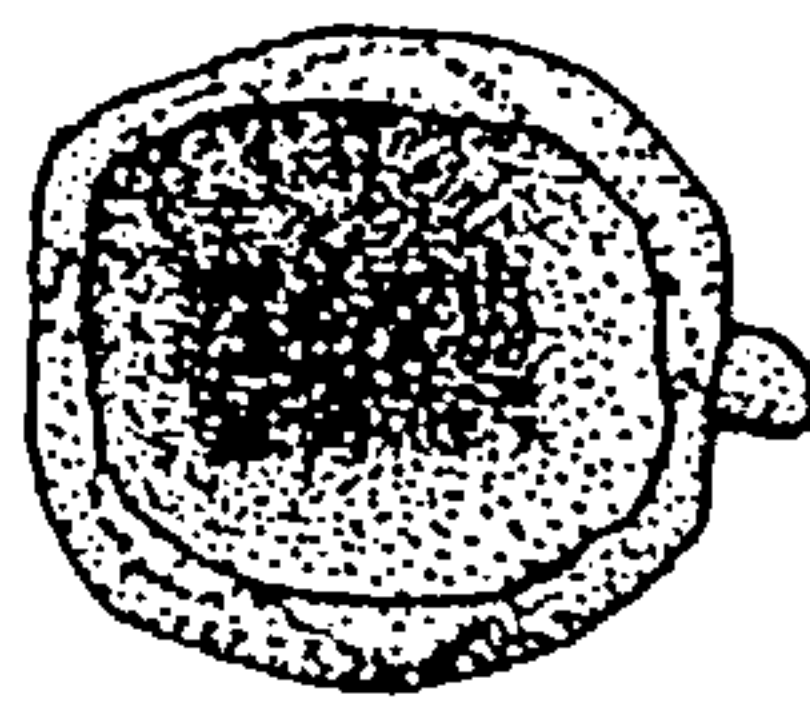


Fig. 56: The Minster Hoard (Ref. No. 20): Complete Socketed Axes (iv)

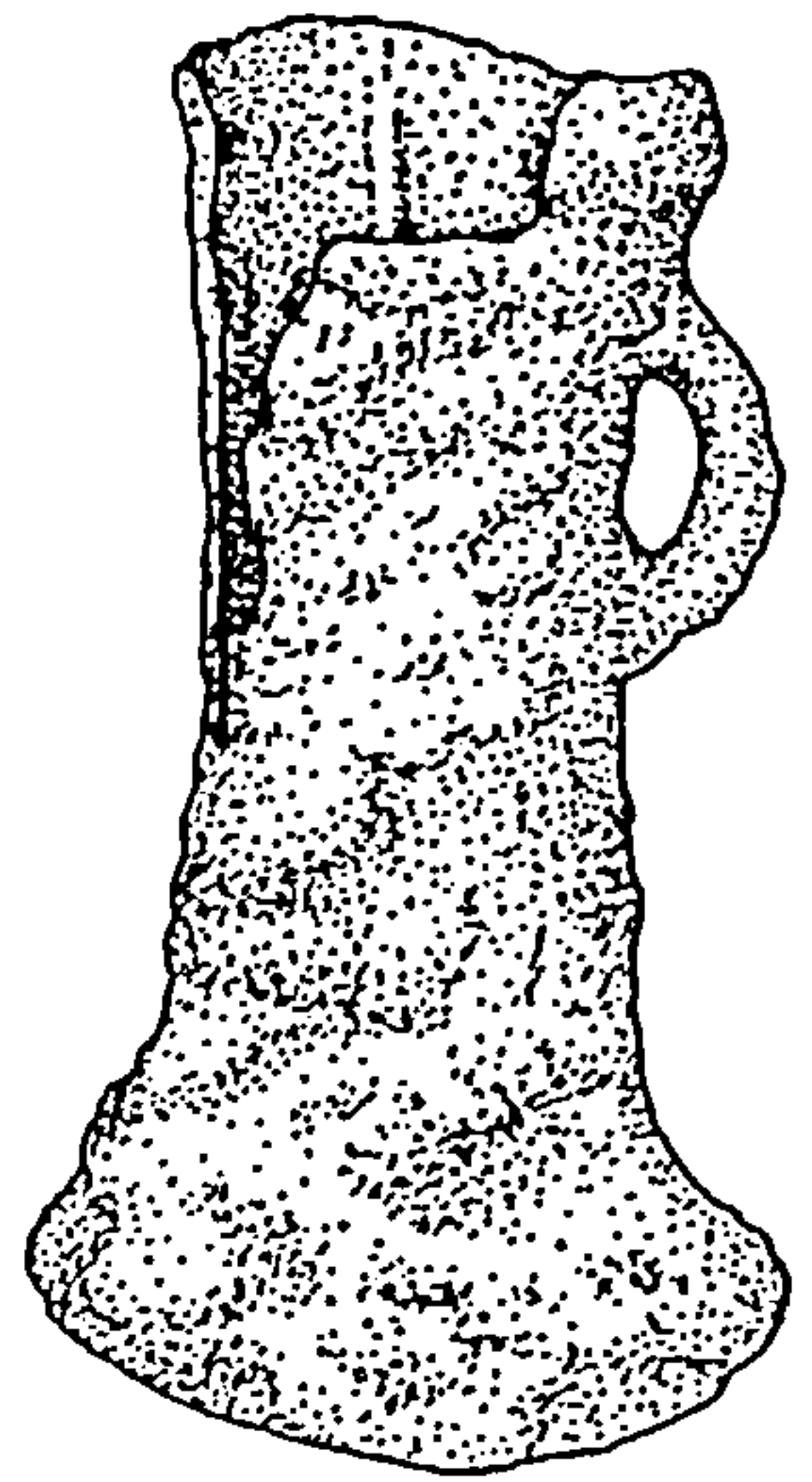
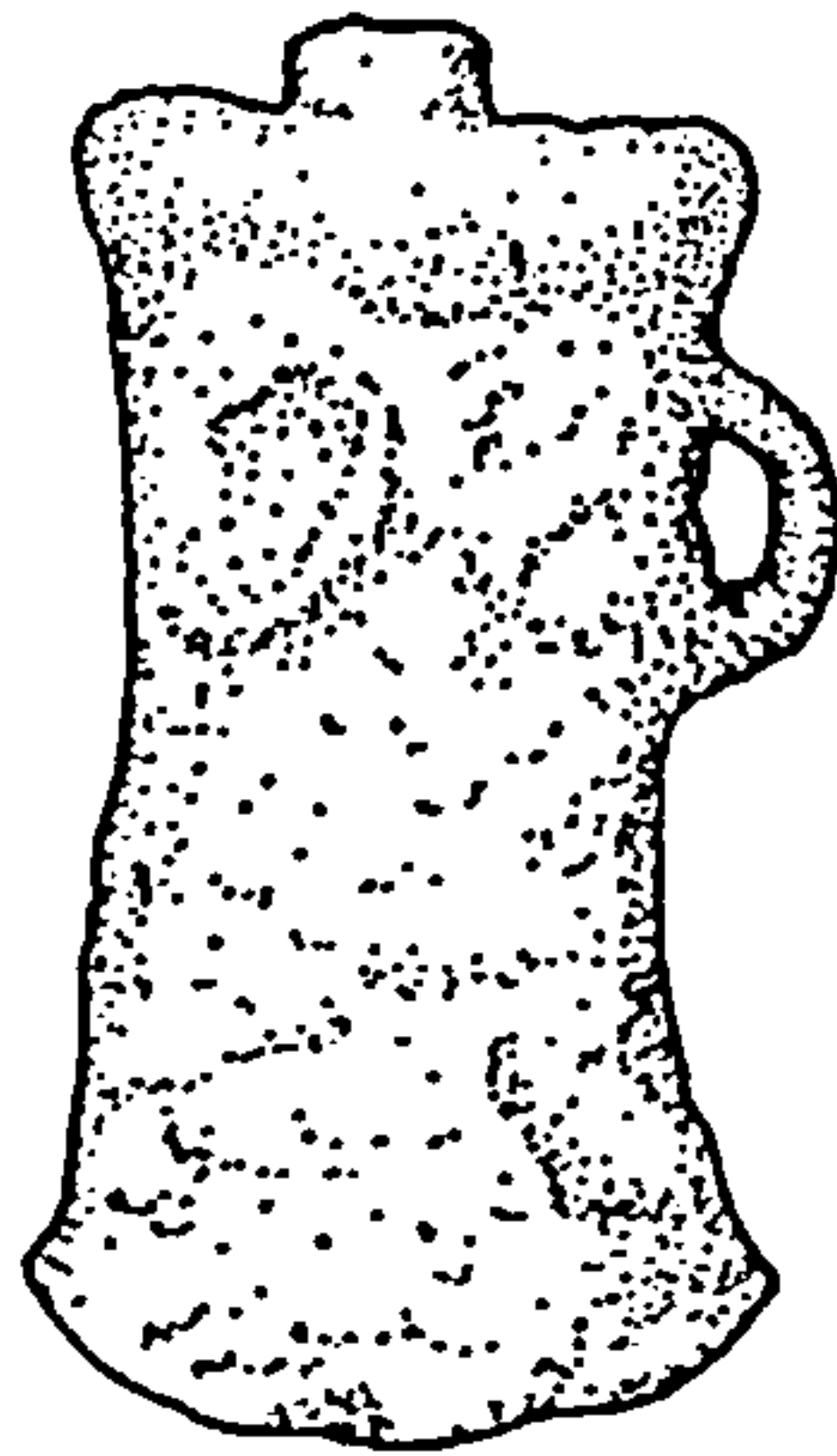
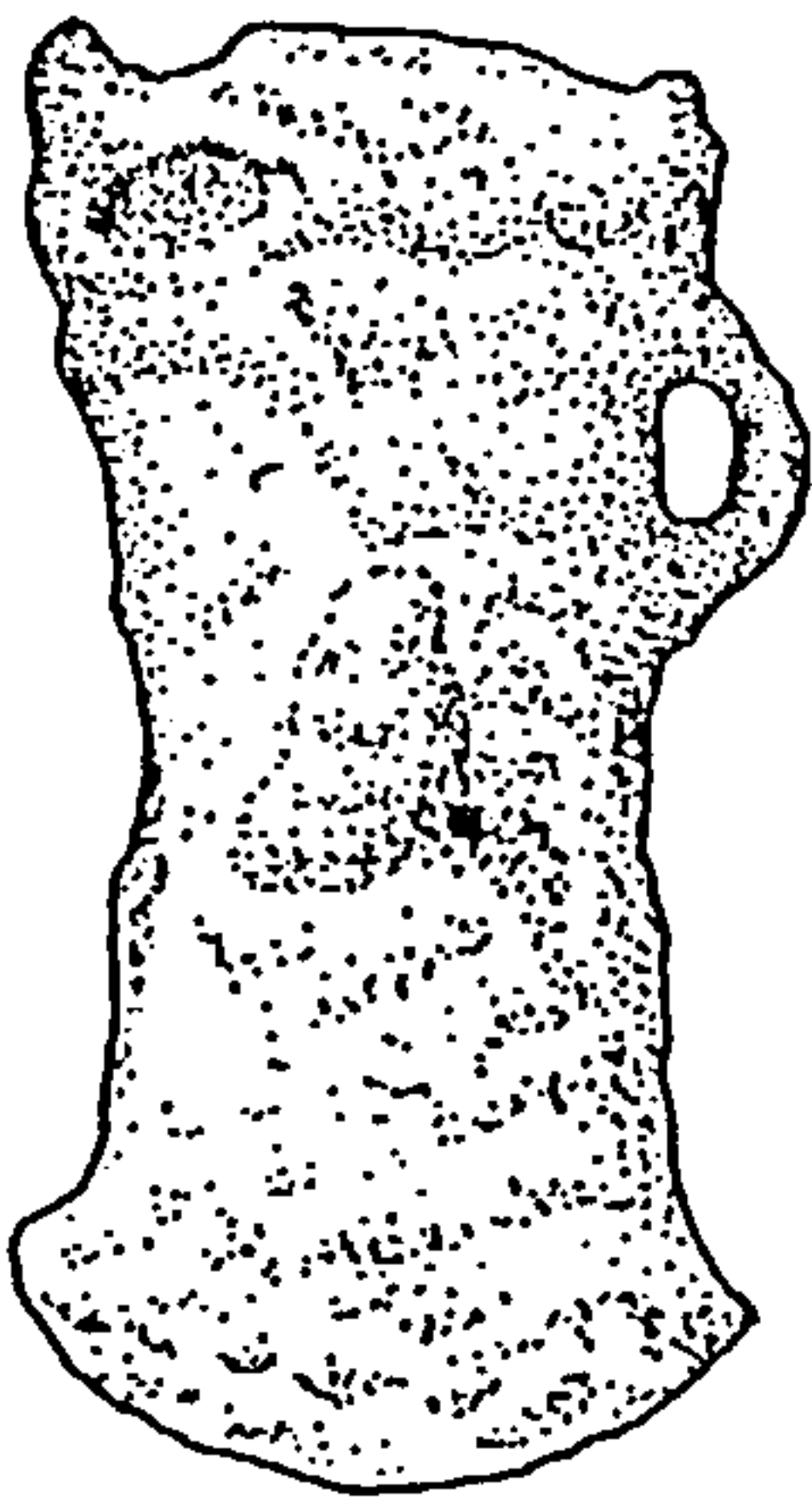
20/22



20/23

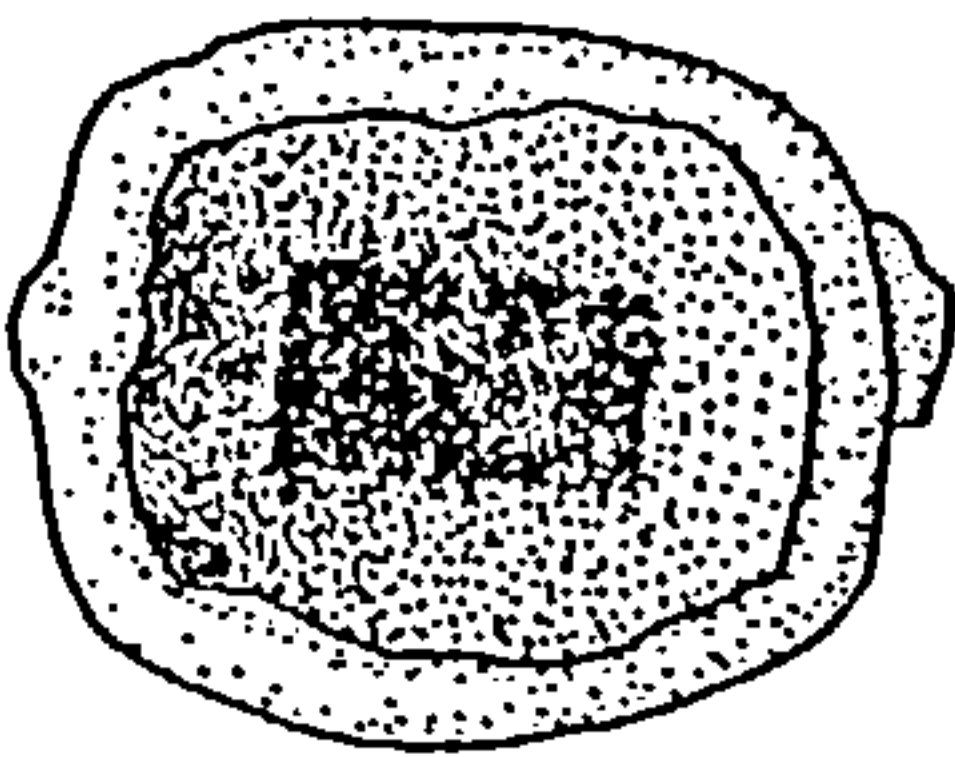


20/24

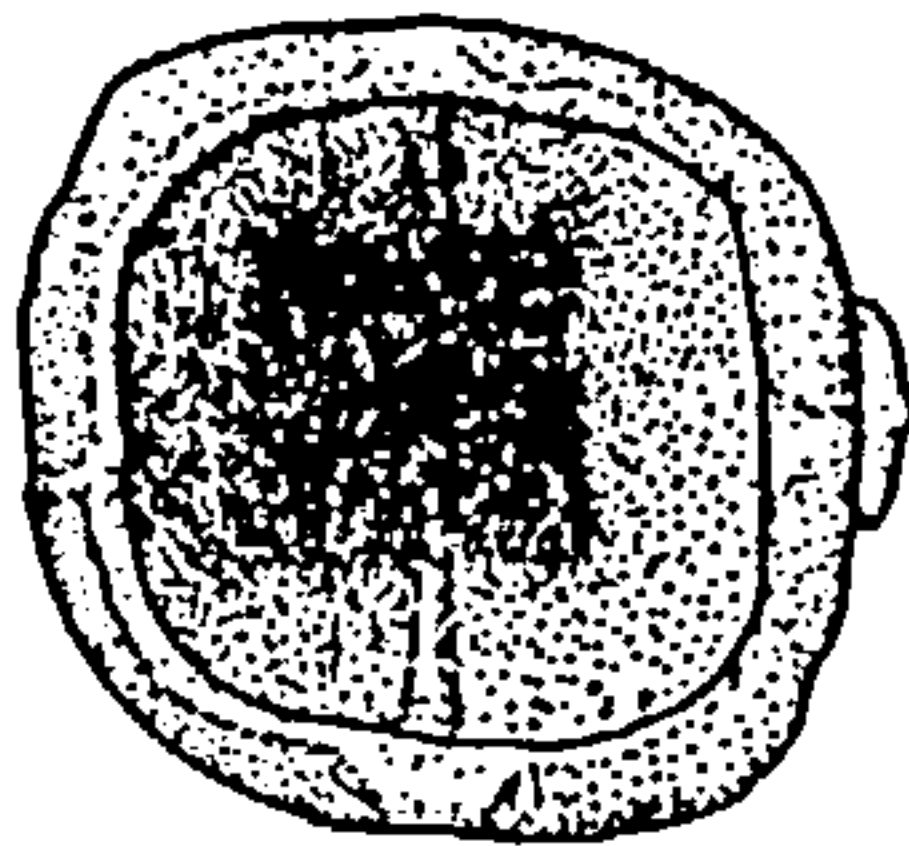


0 2cm

20/25



20/26



20/27

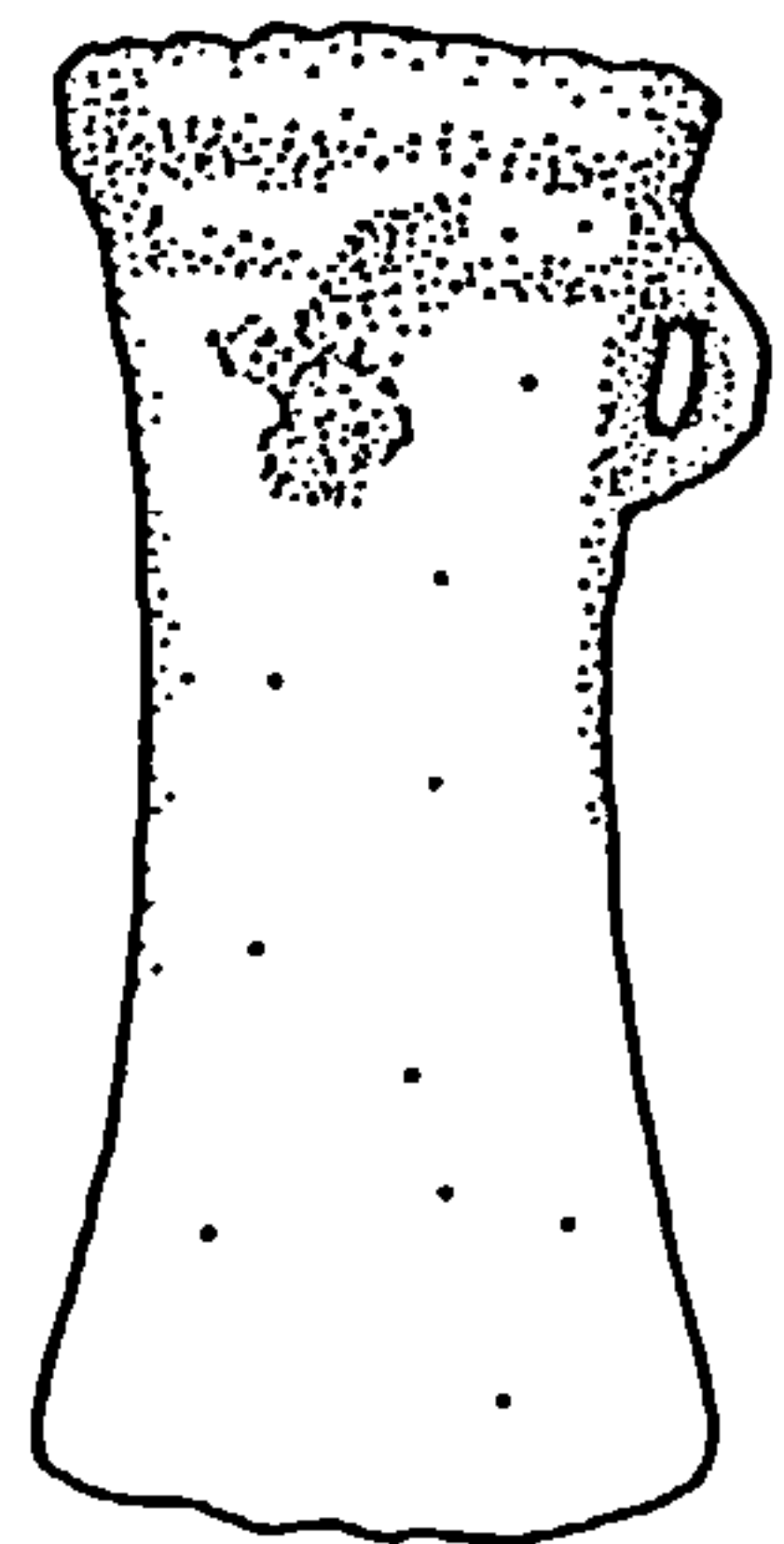
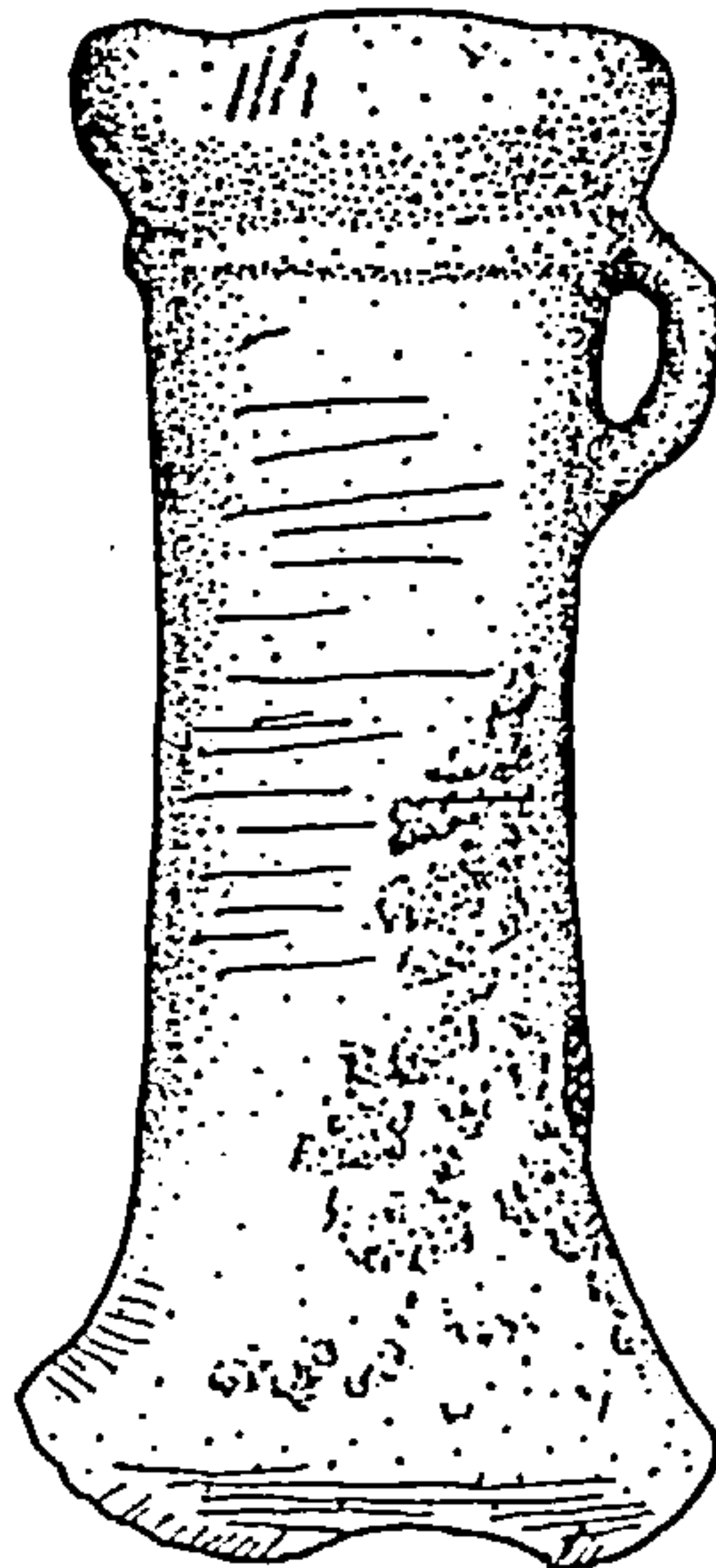
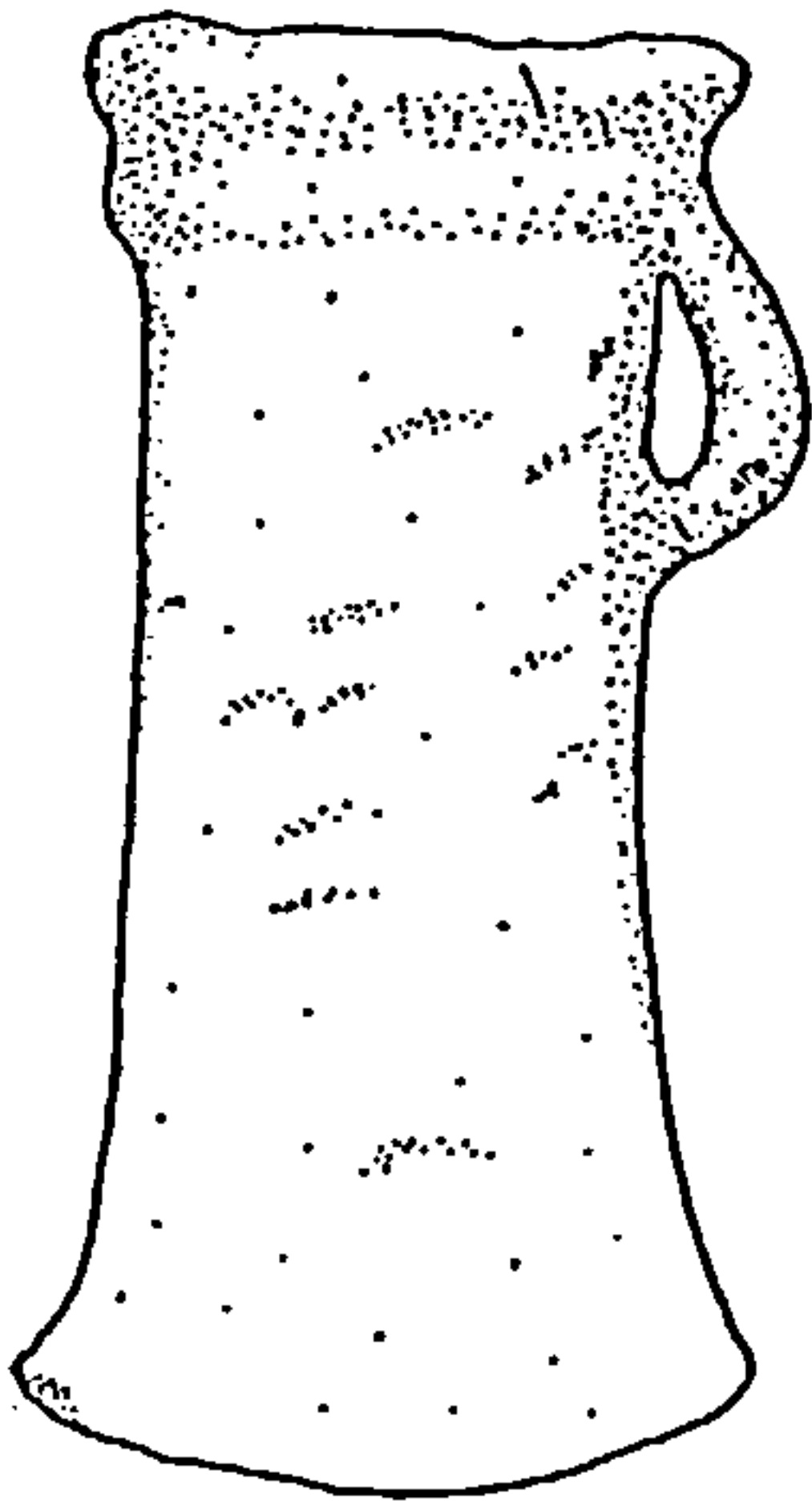
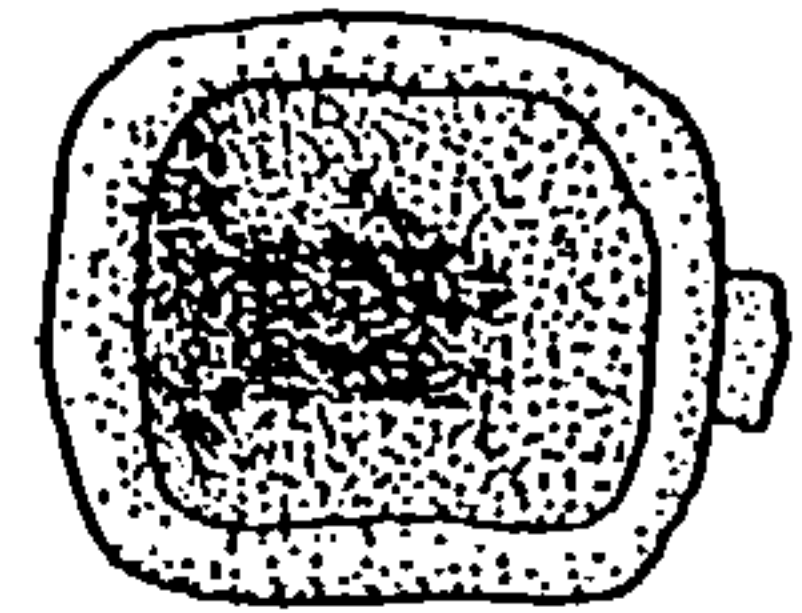
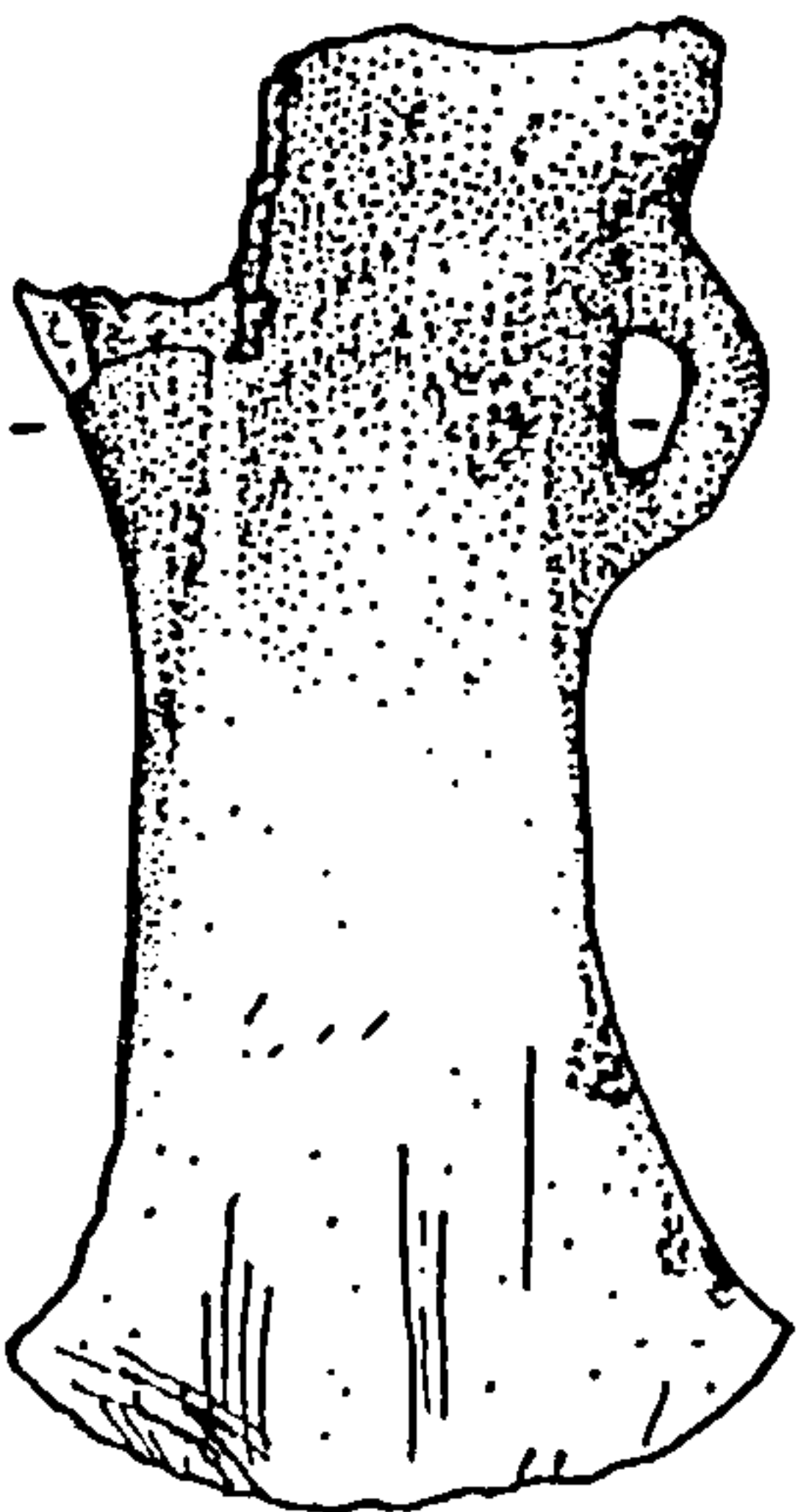
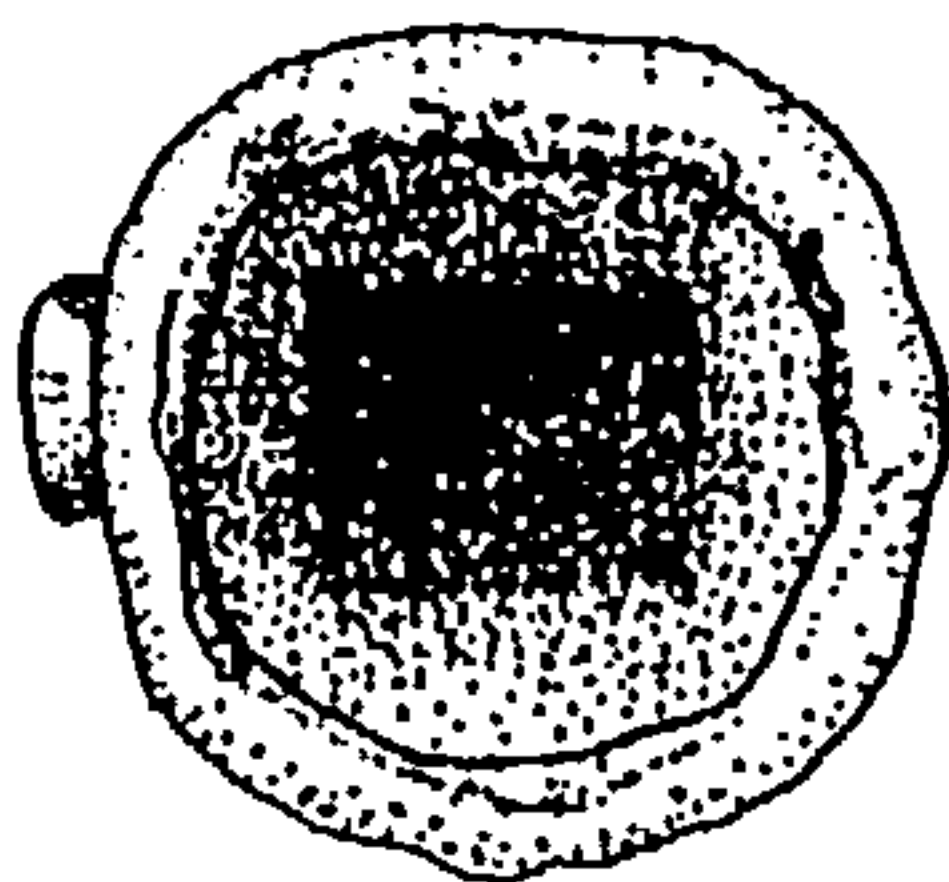


Fig. 57: The Minster Hoard (Ref. No. 20): Complete Socketed Axes (v)

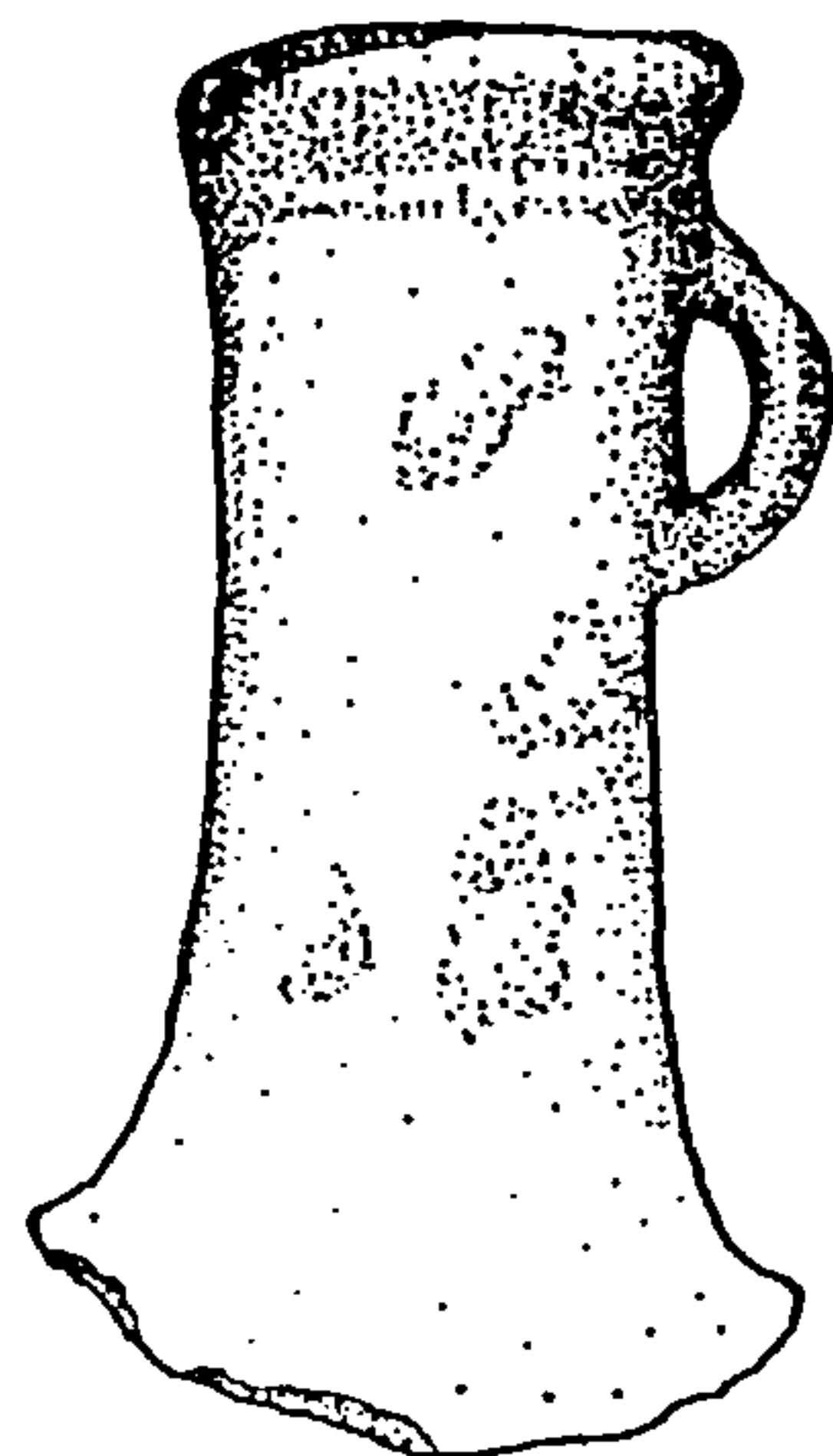
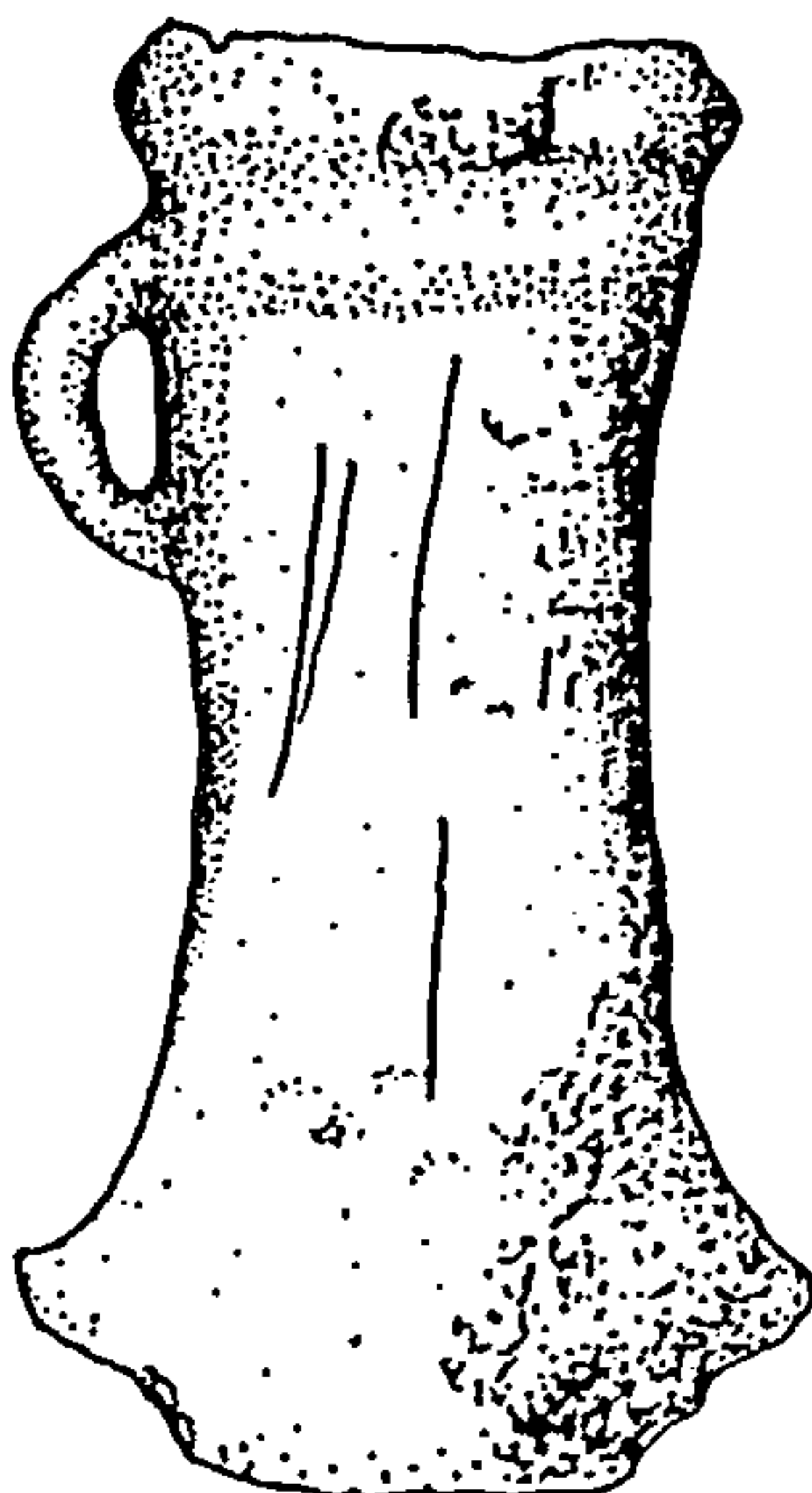
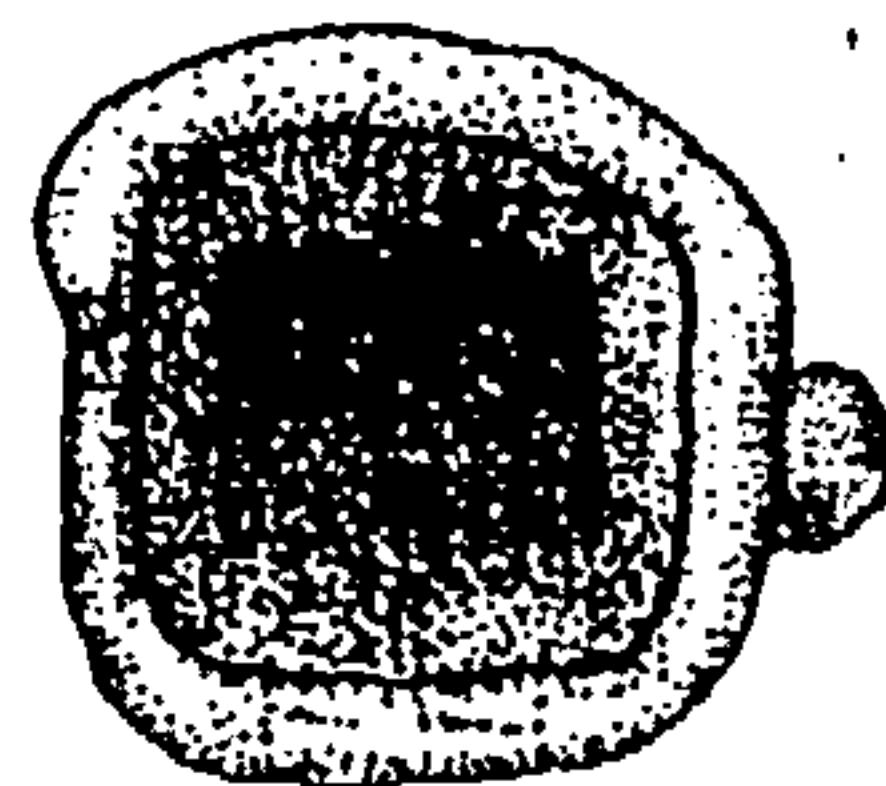
20/28



20/29

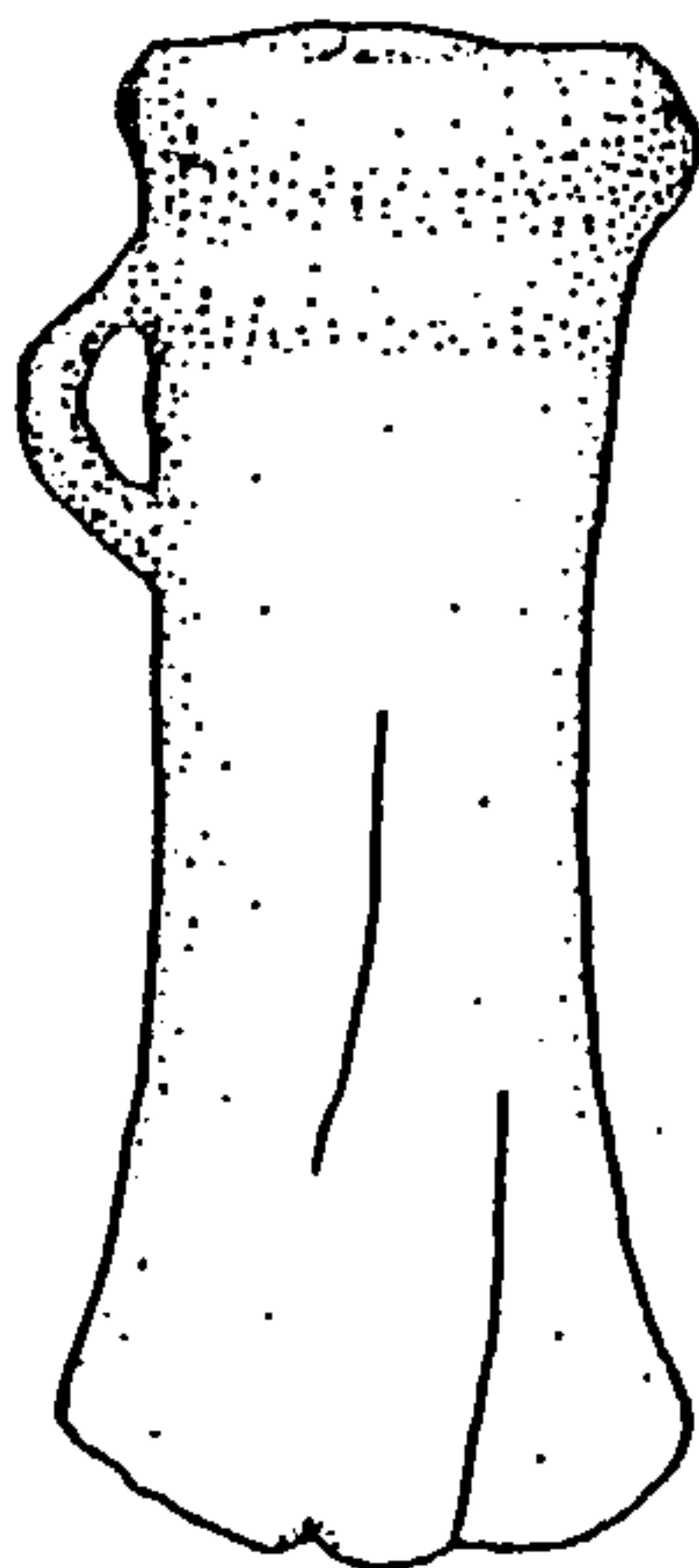
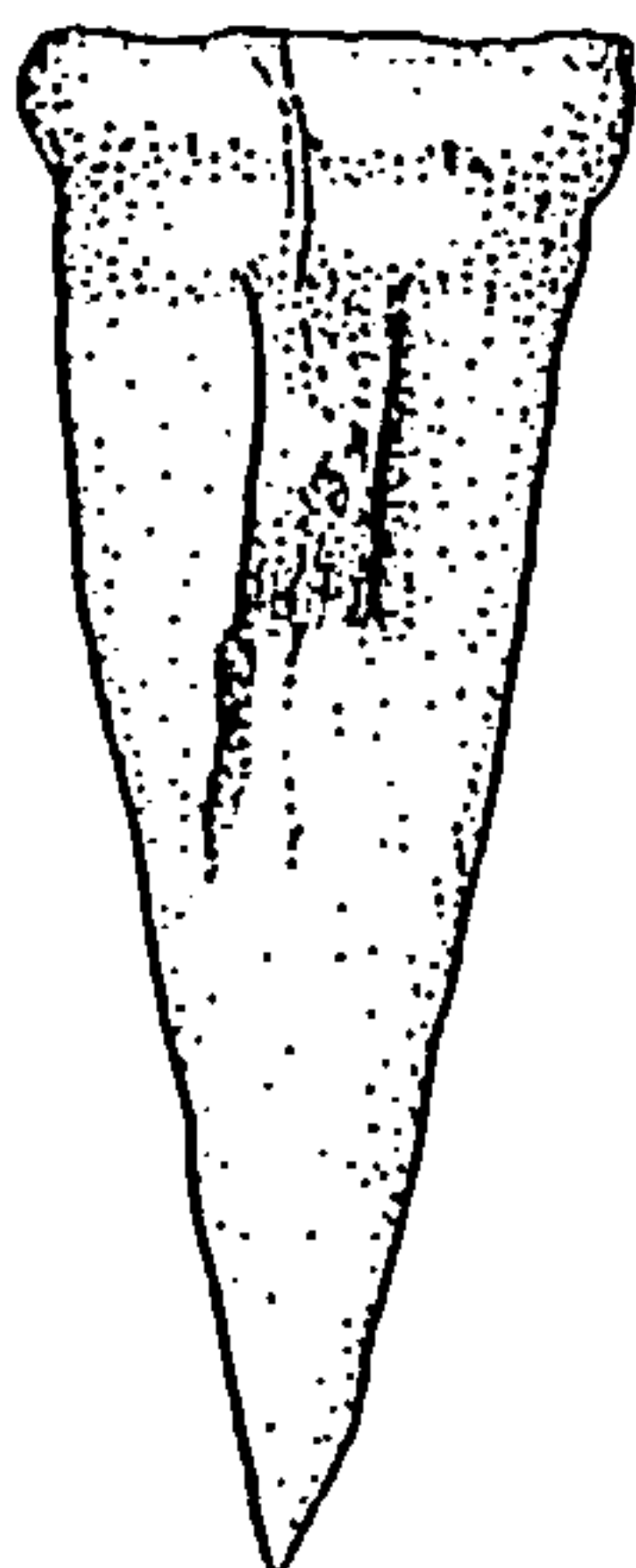
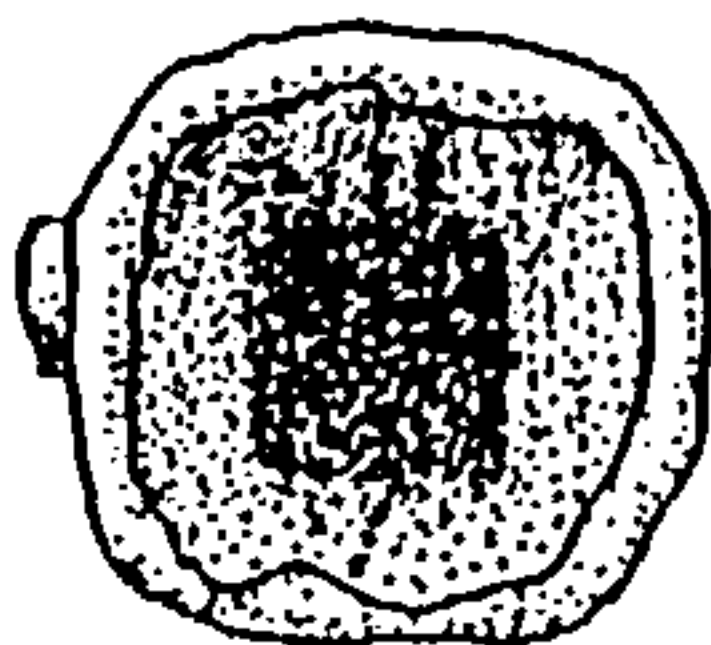


20/30



0 2cm

20/31



20/32

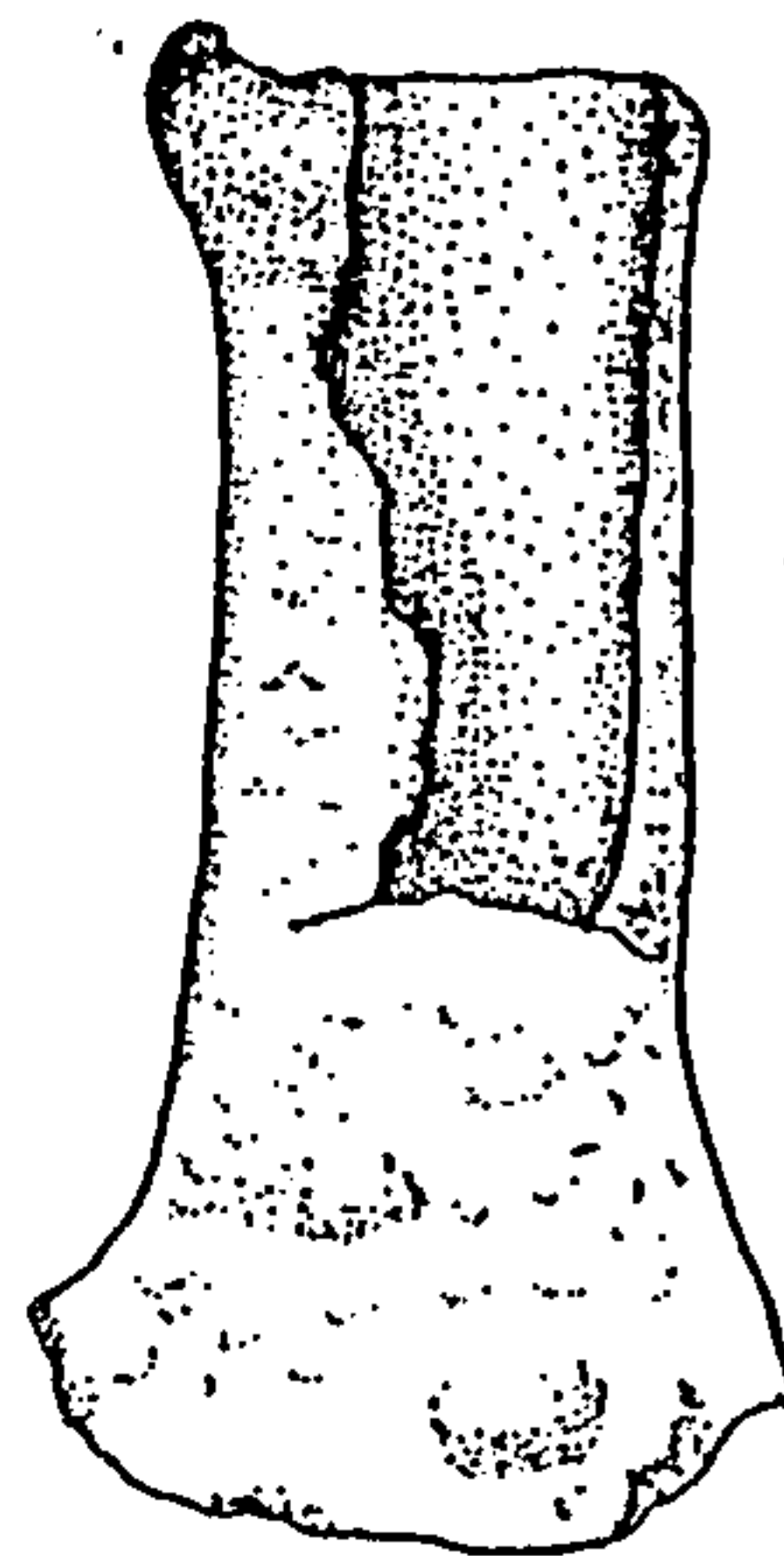
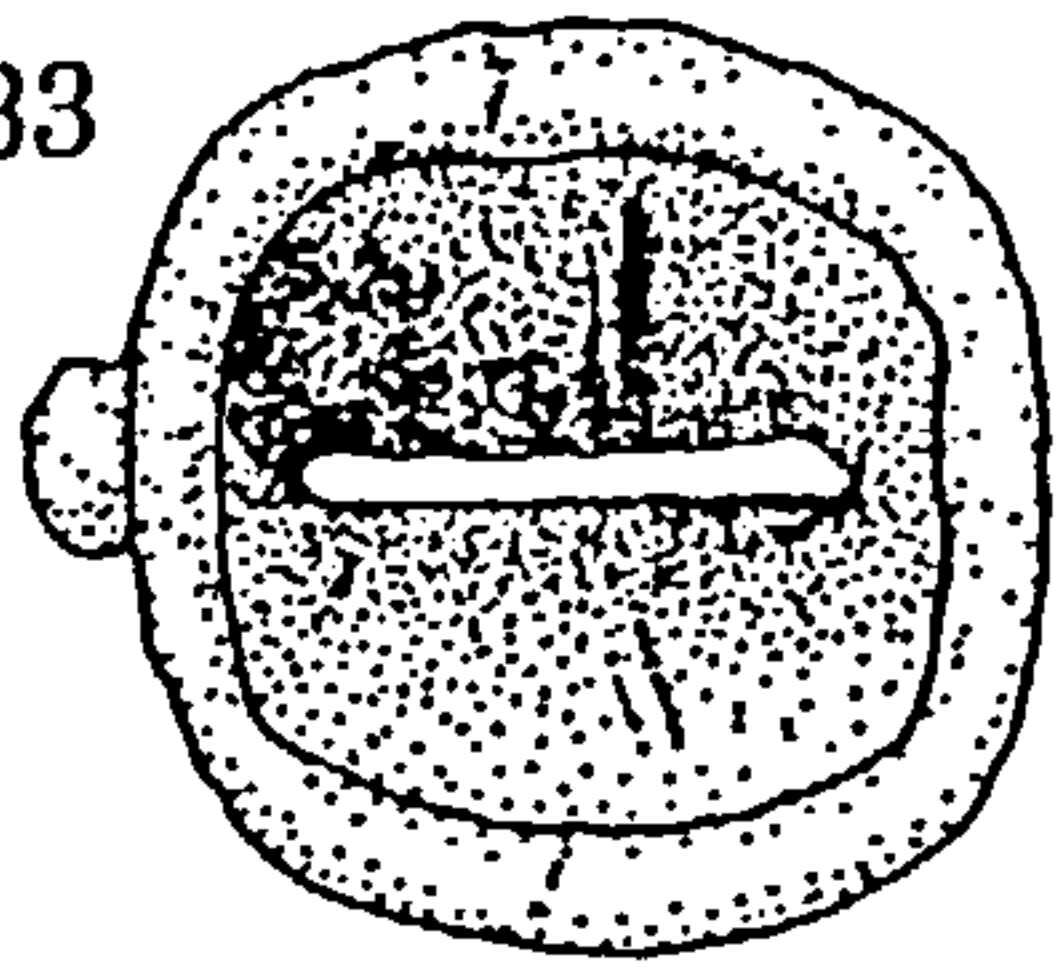
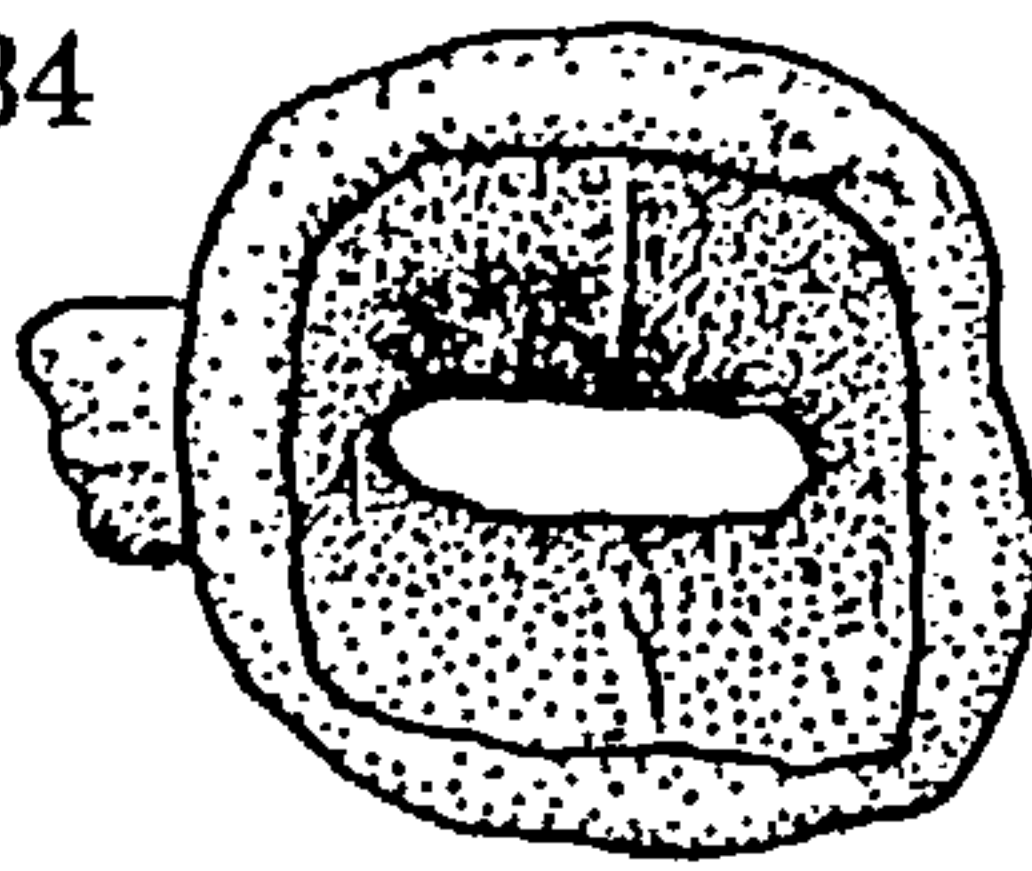


Fig. 58: The Minster Hoard (Ref. No. 20): Complete Socketed Axes (vi)

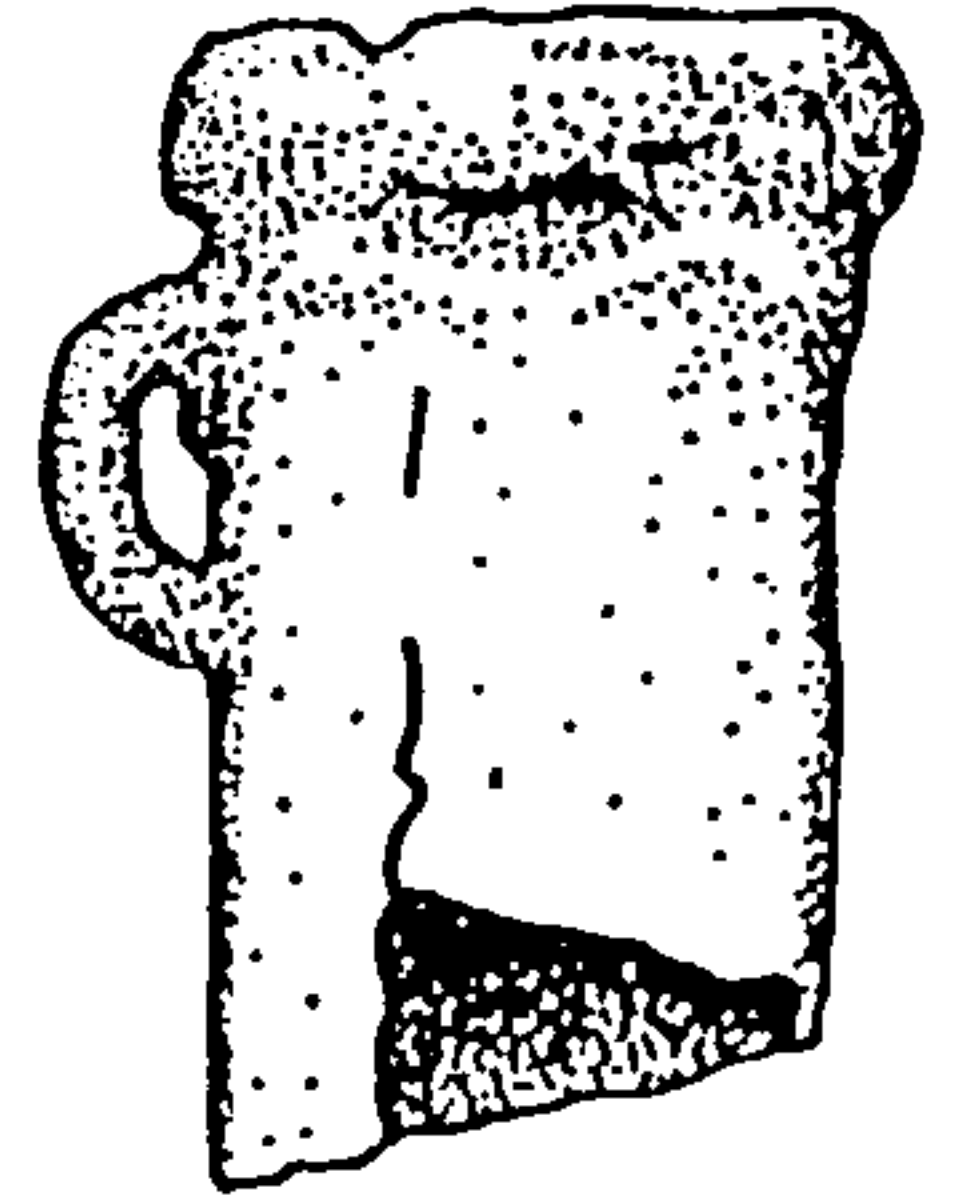
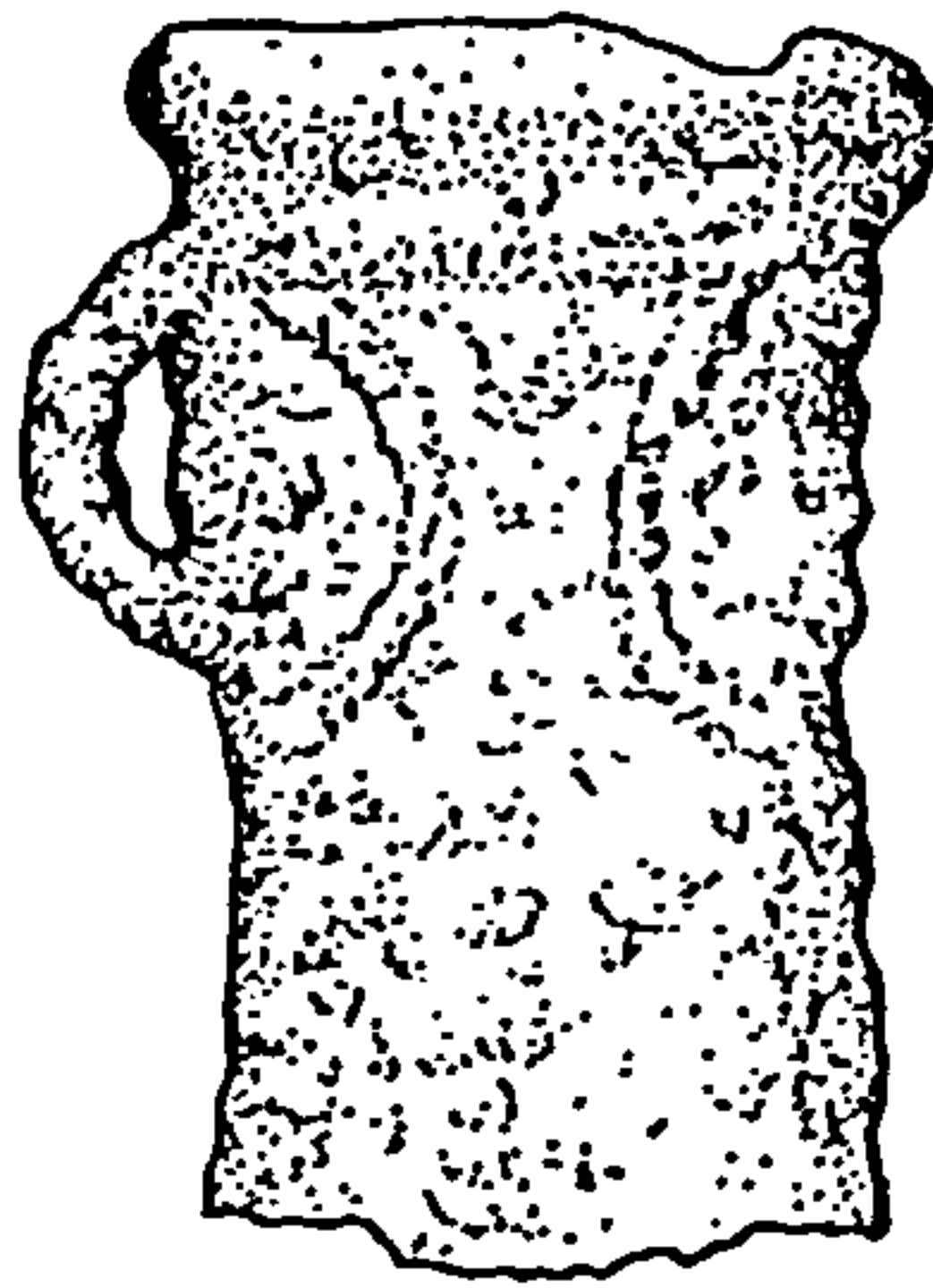
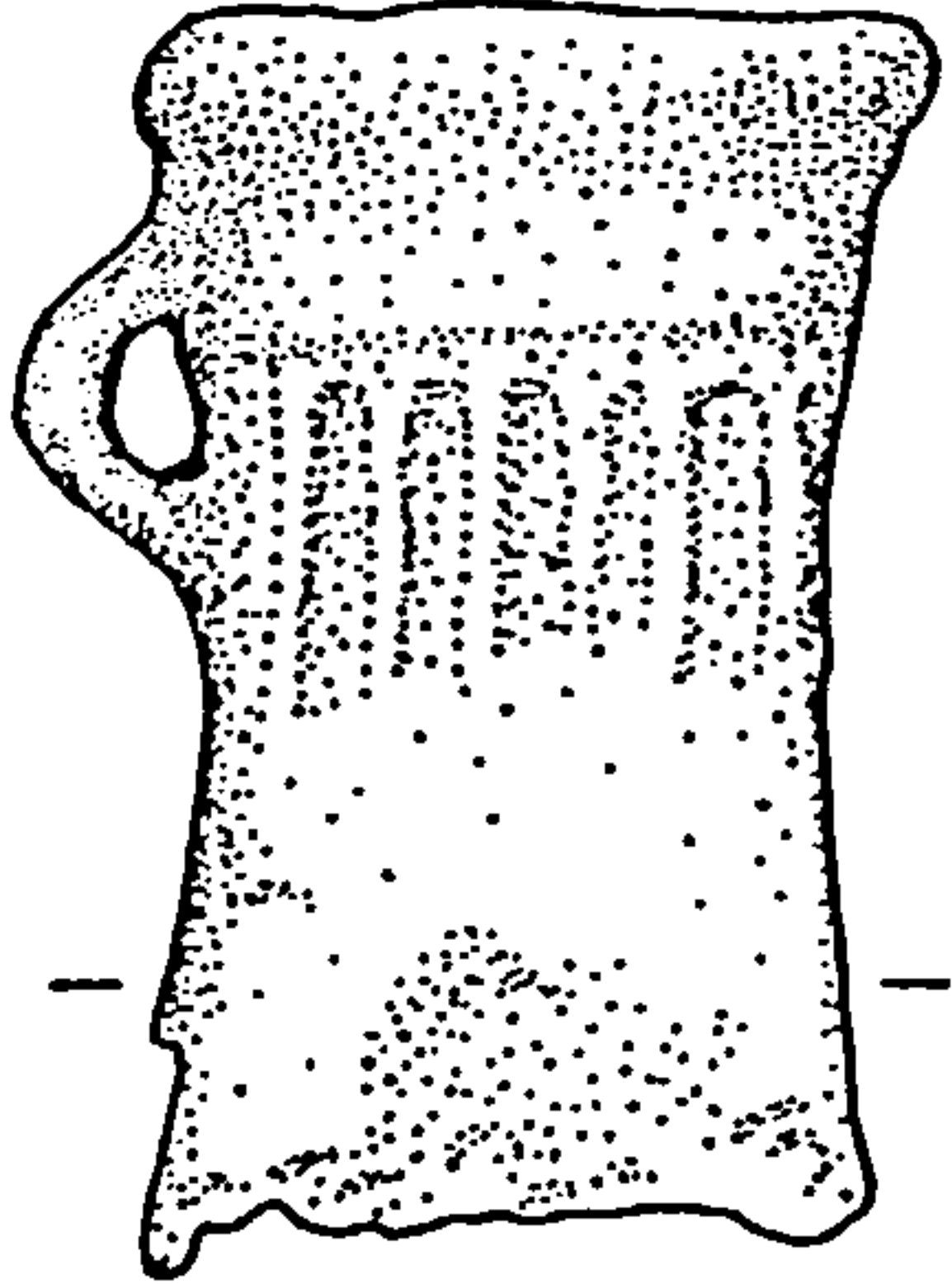
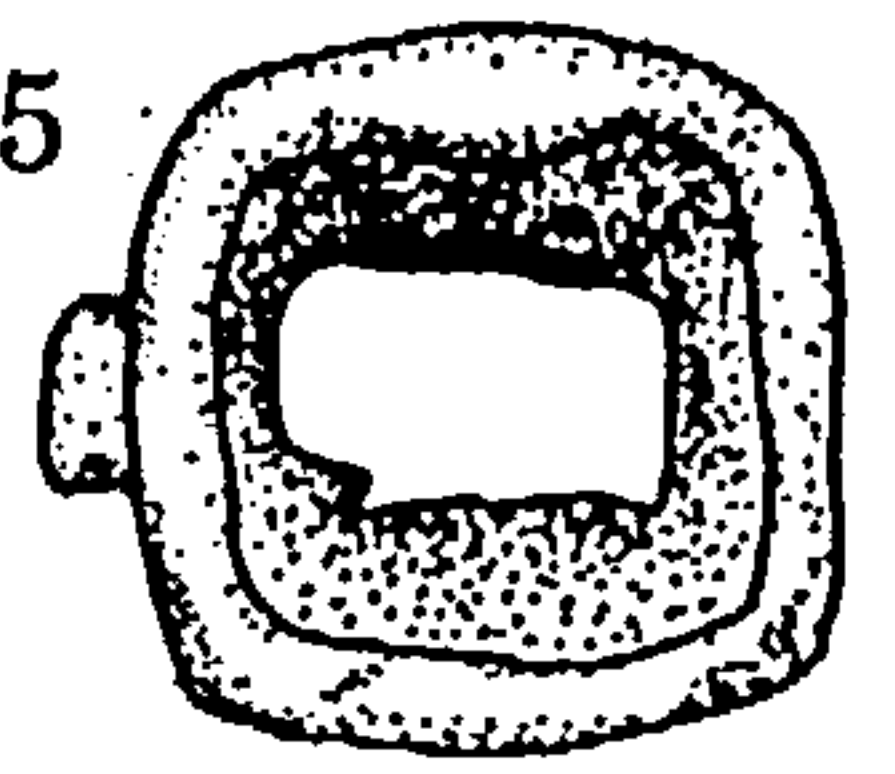
20/33



20/34

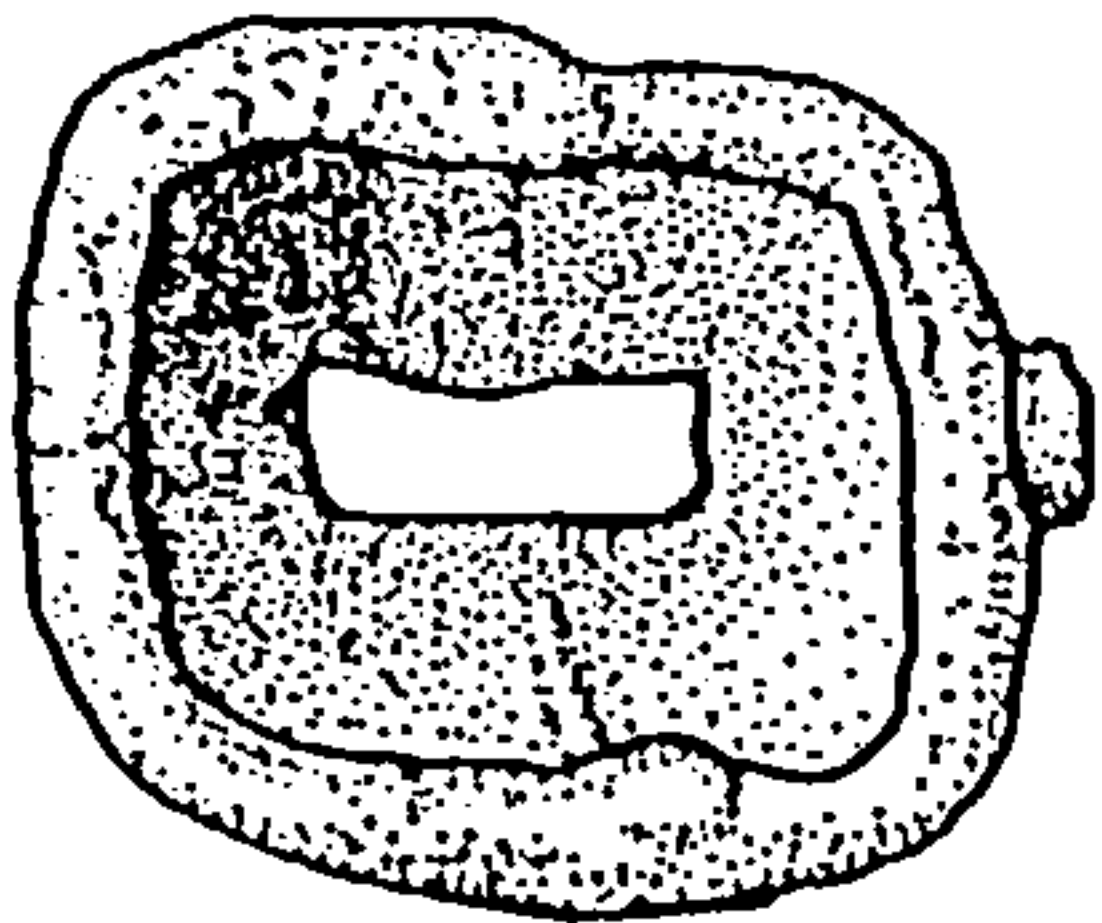


20/35

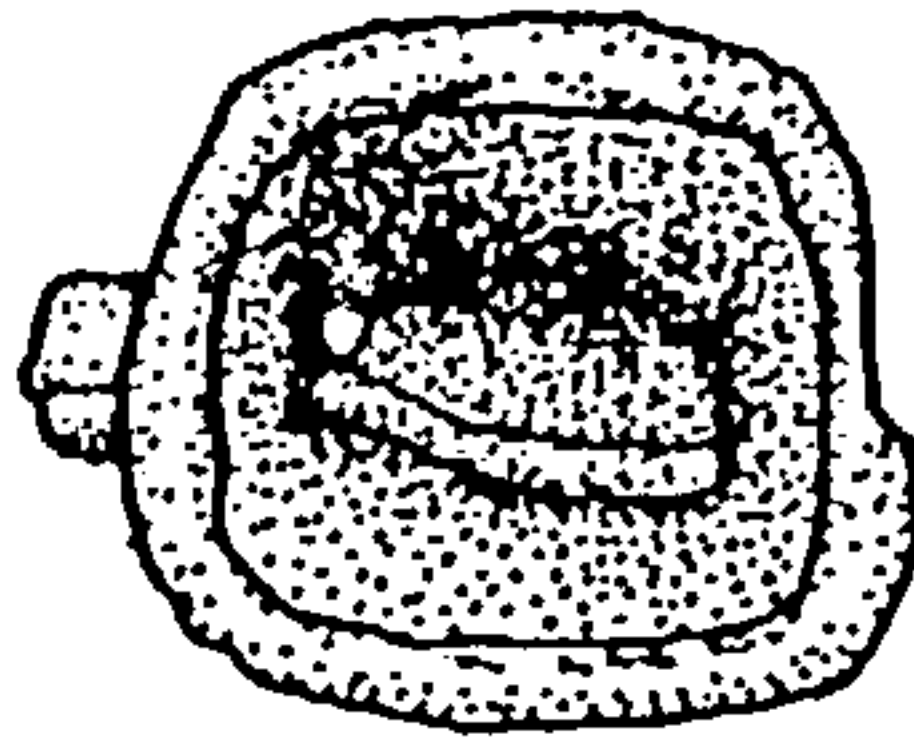


0 2cm

20/36



20/37



20/38

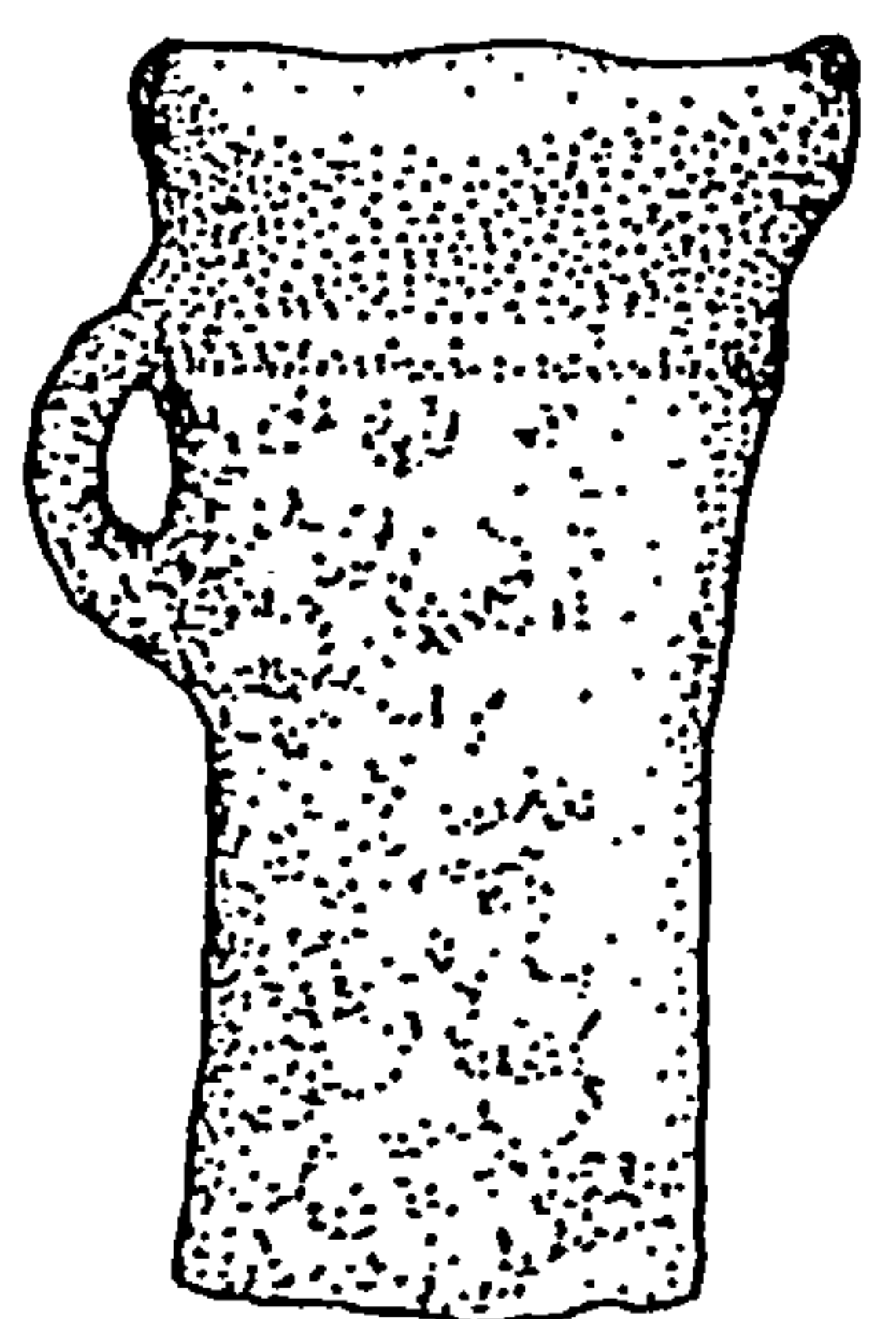
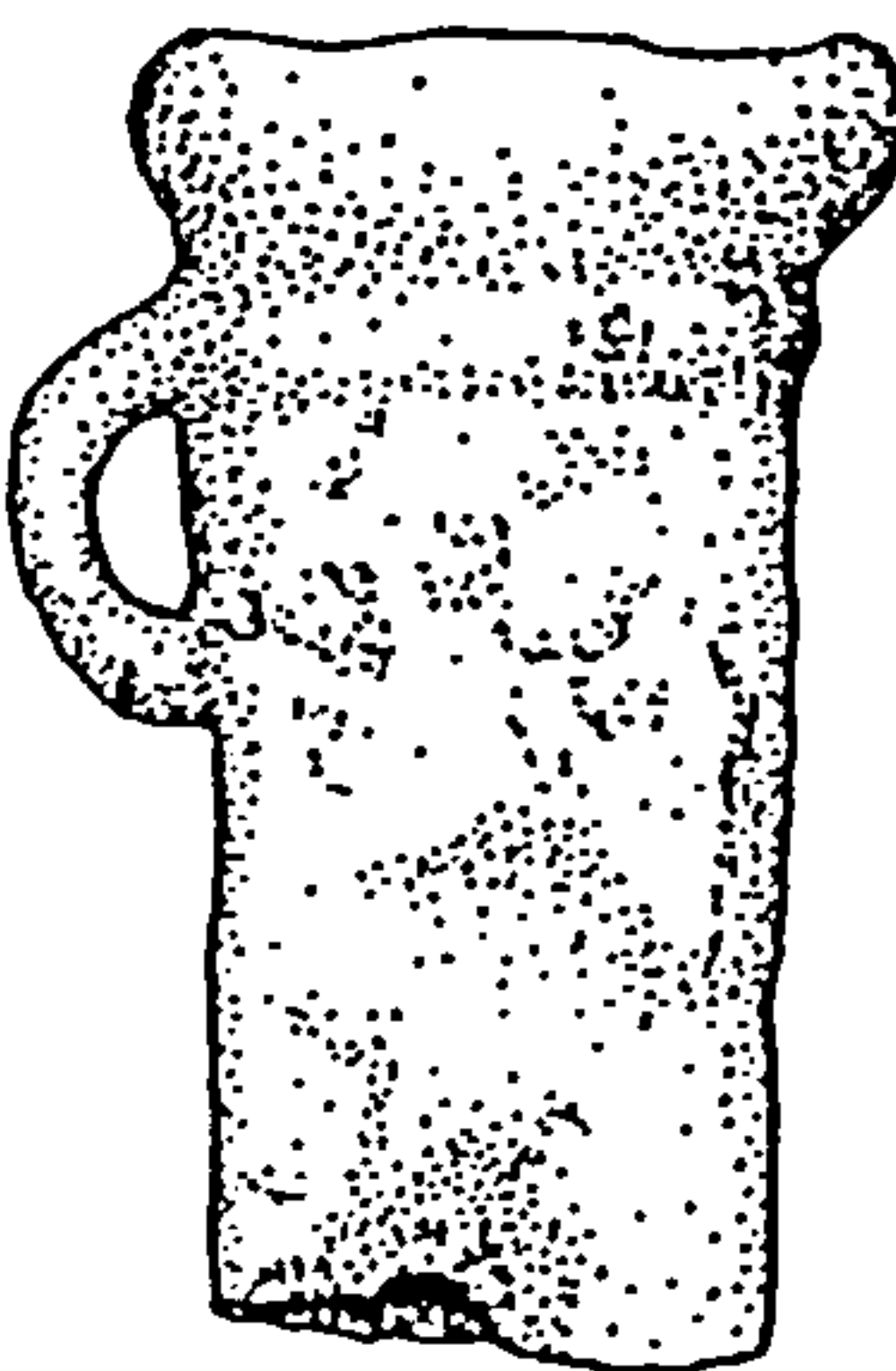
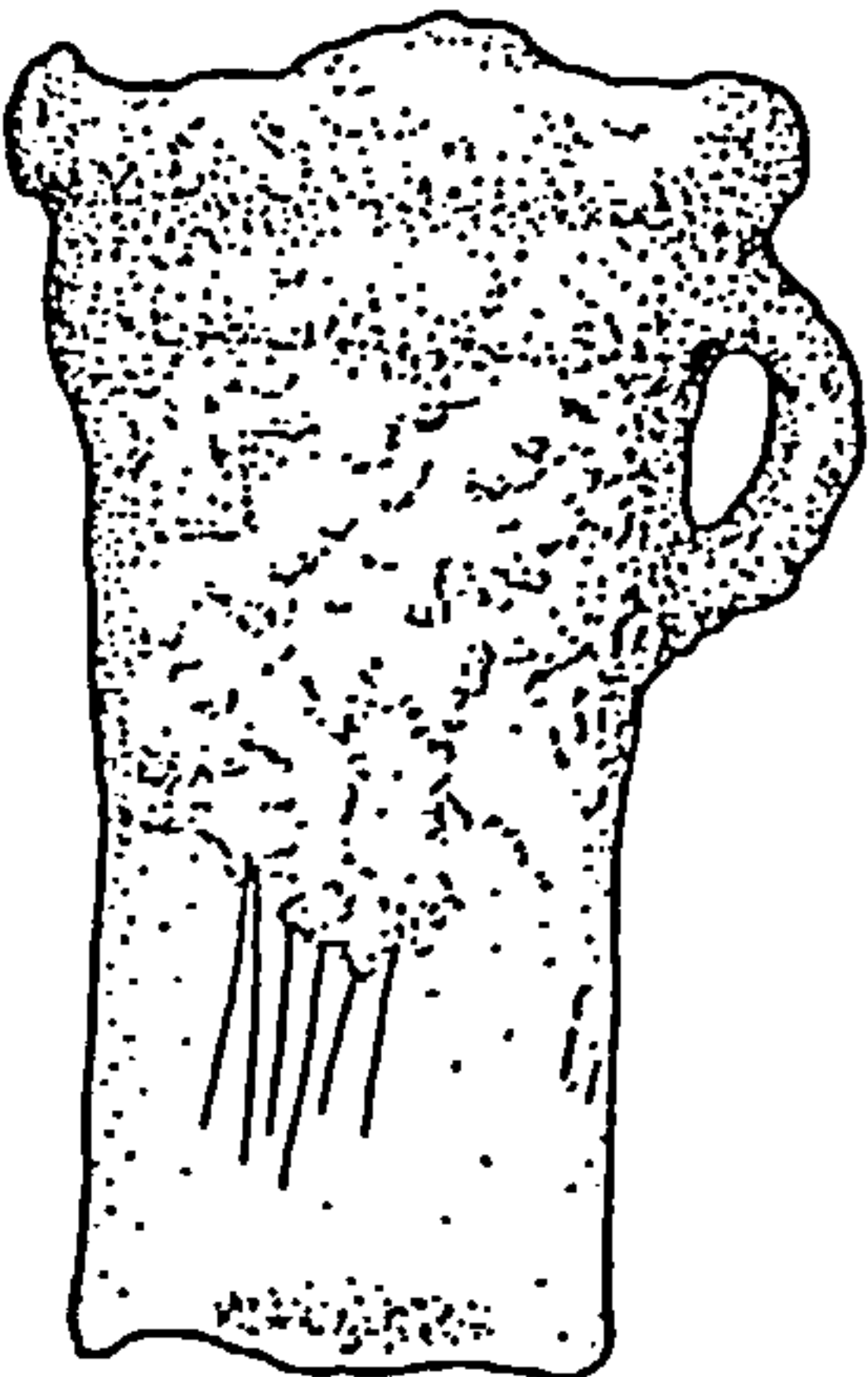
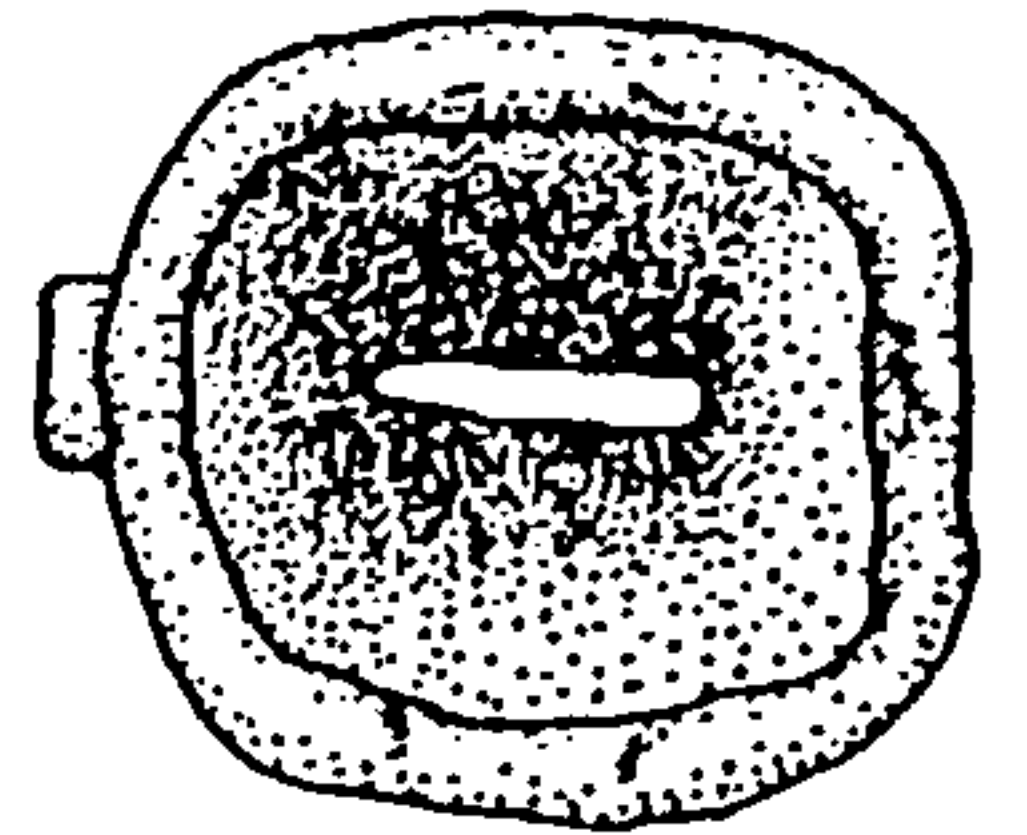


Fig. 59: The Minster Hoard (Ref. No. 20): Socketed Axe Fragments (i)

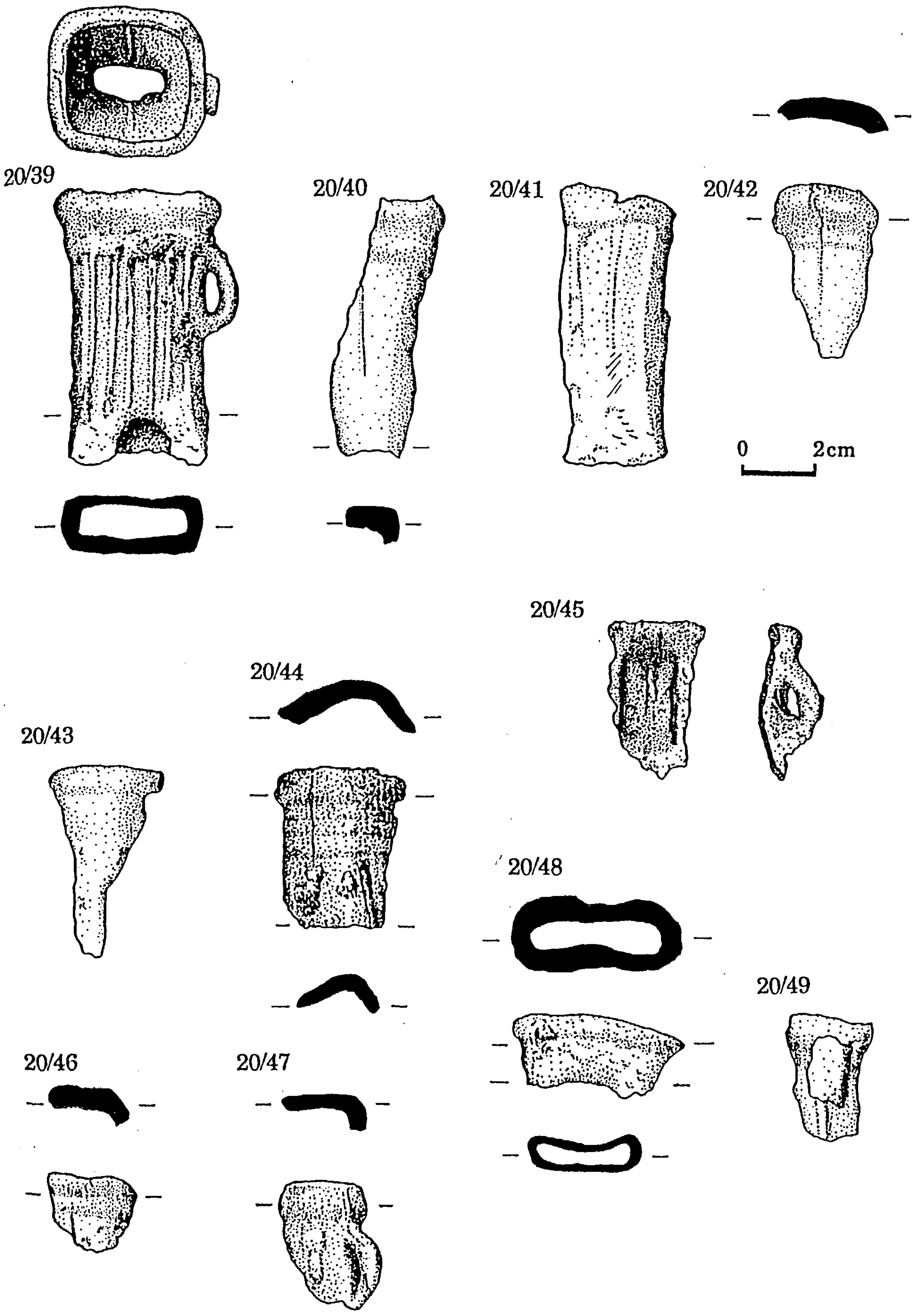


Fig. 60: The Minster Hoard (Ref. No. 20): Socketed Axe Fragments (ii)

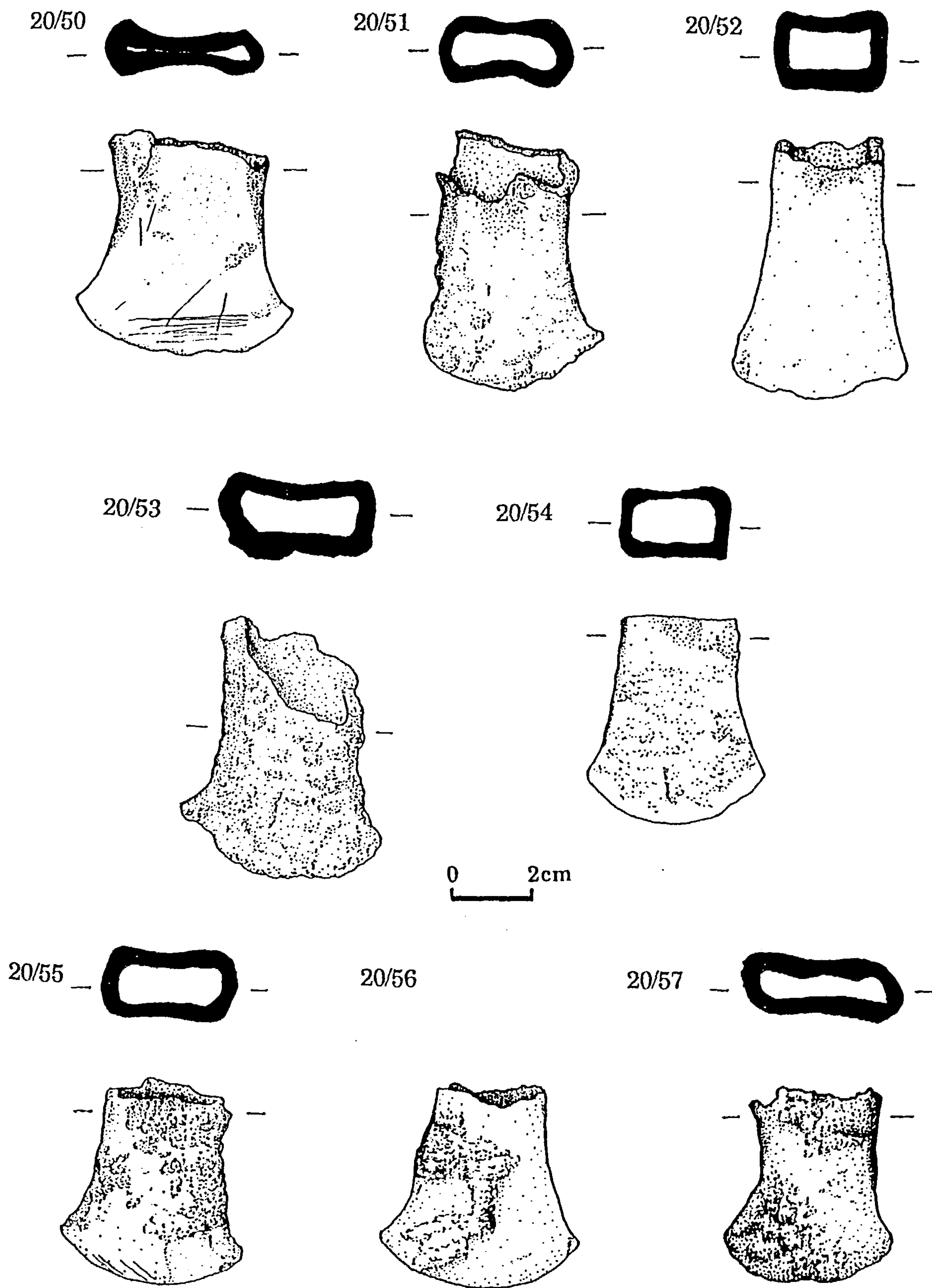


Fig. 61: The Minster Hoard (Ref. No. 20): Socketed Axe Fragments (iii)

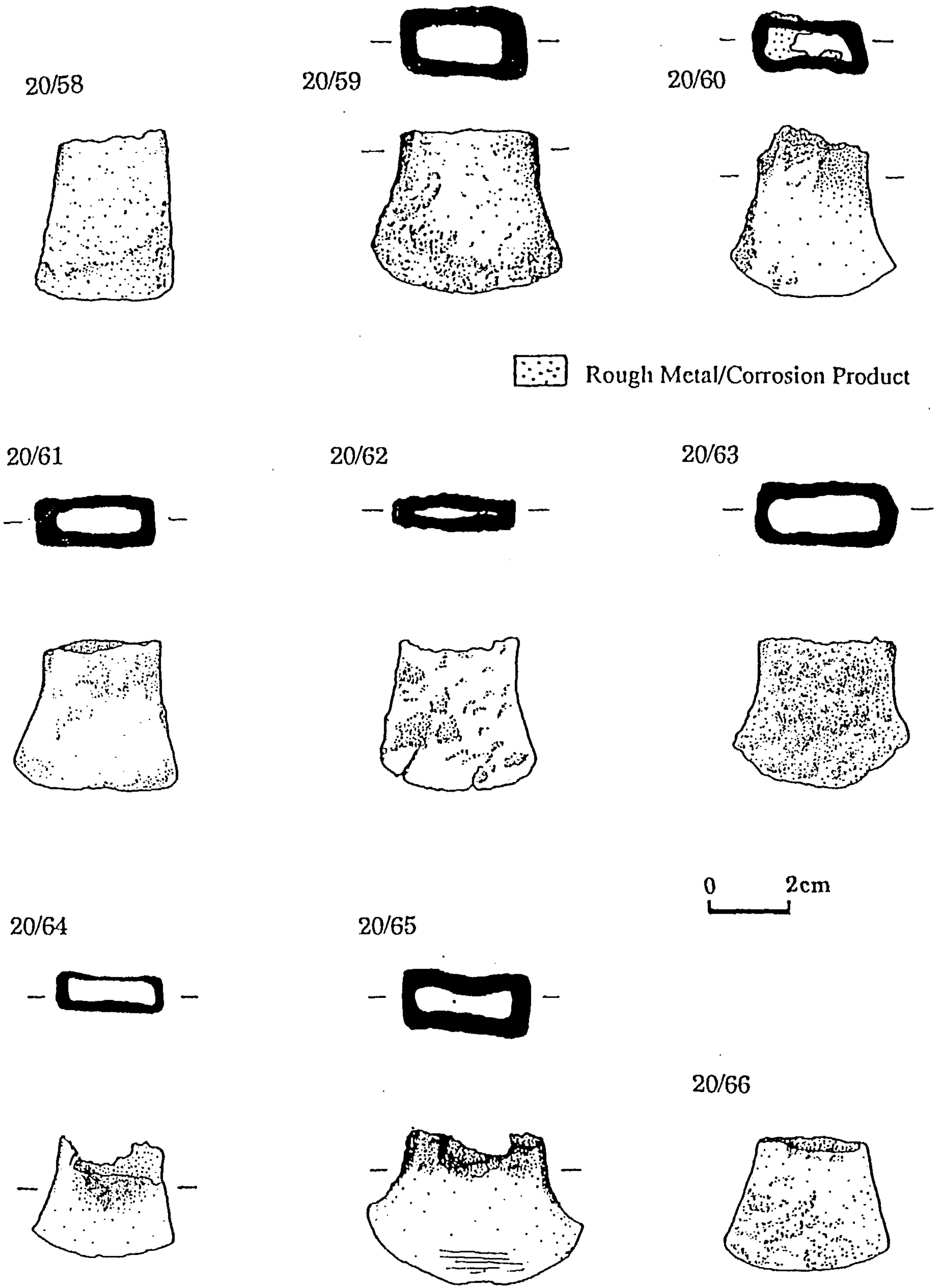


Fig. 62: The Minster Hoard (Ref. No. 20): Socketed Axe Fragments (iv)

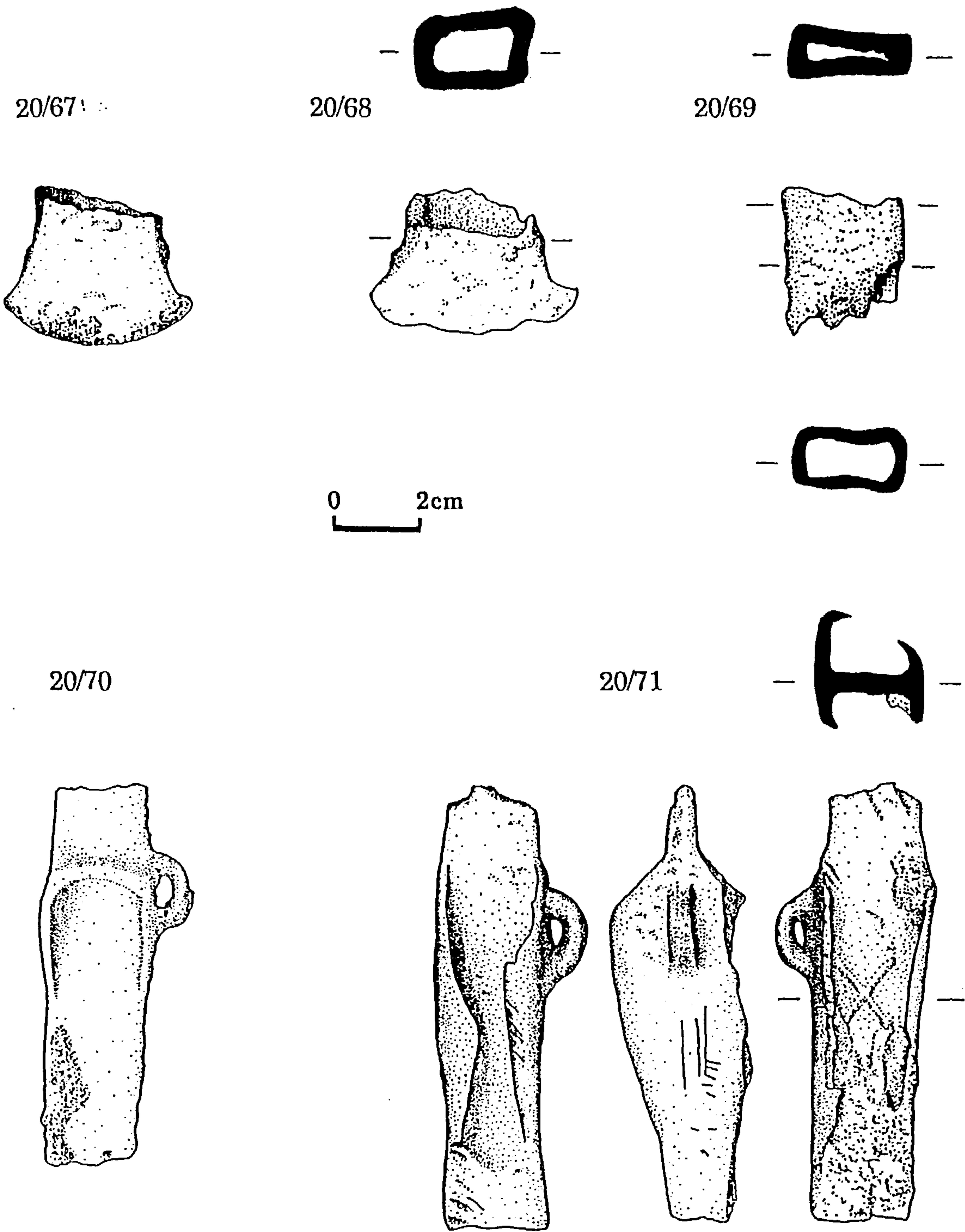
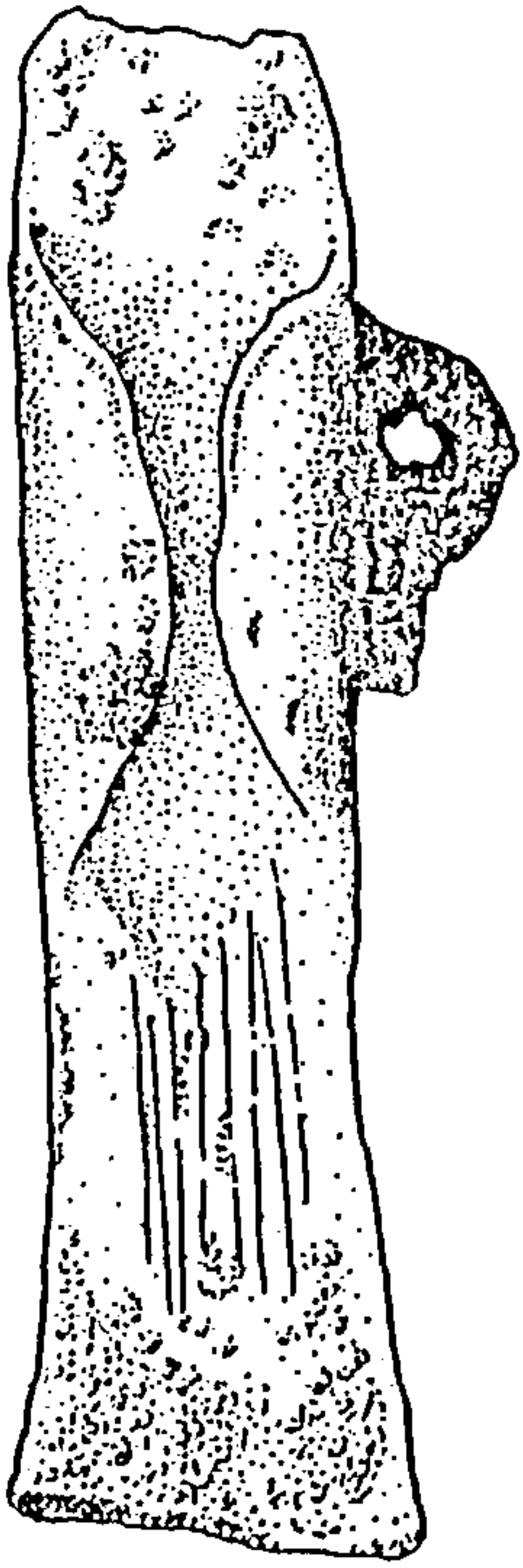
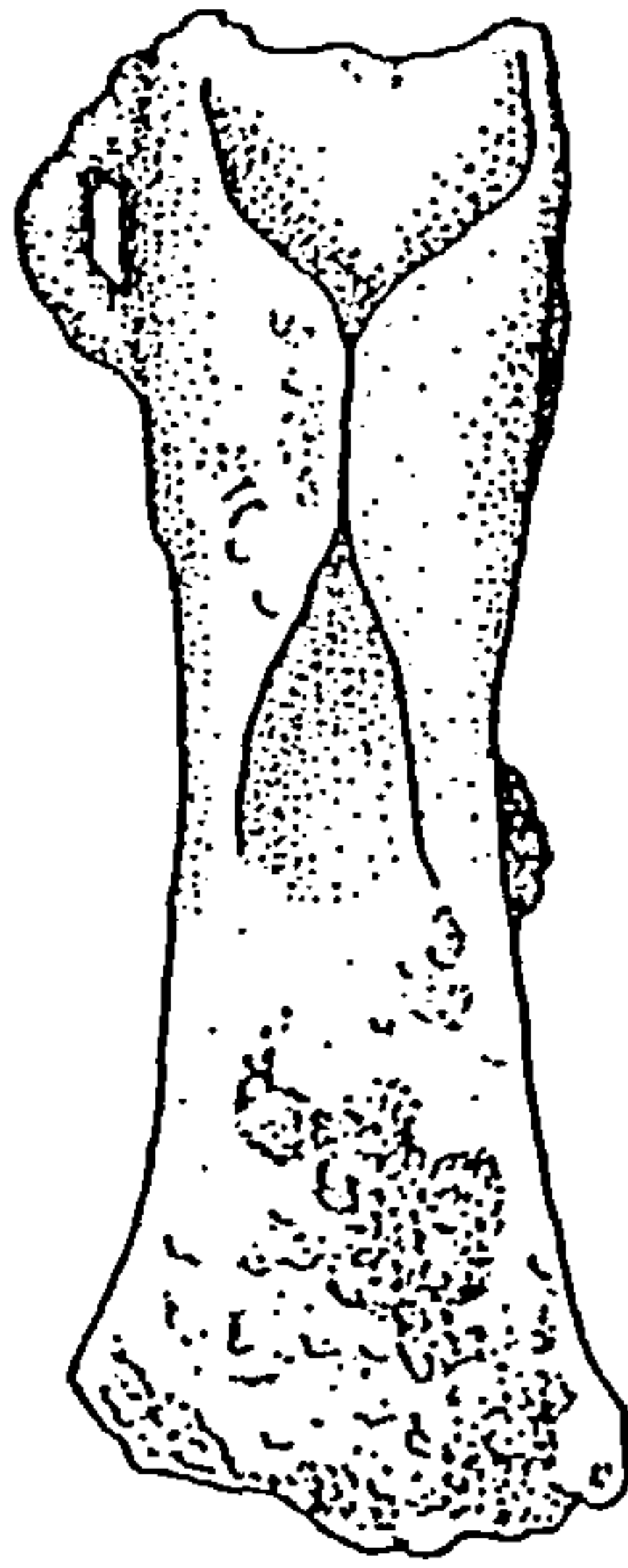


Fig. 63: The Minster Hoard (Ref. No. 20): Socketed Axe Fragments (v) and Winged Axes (i)

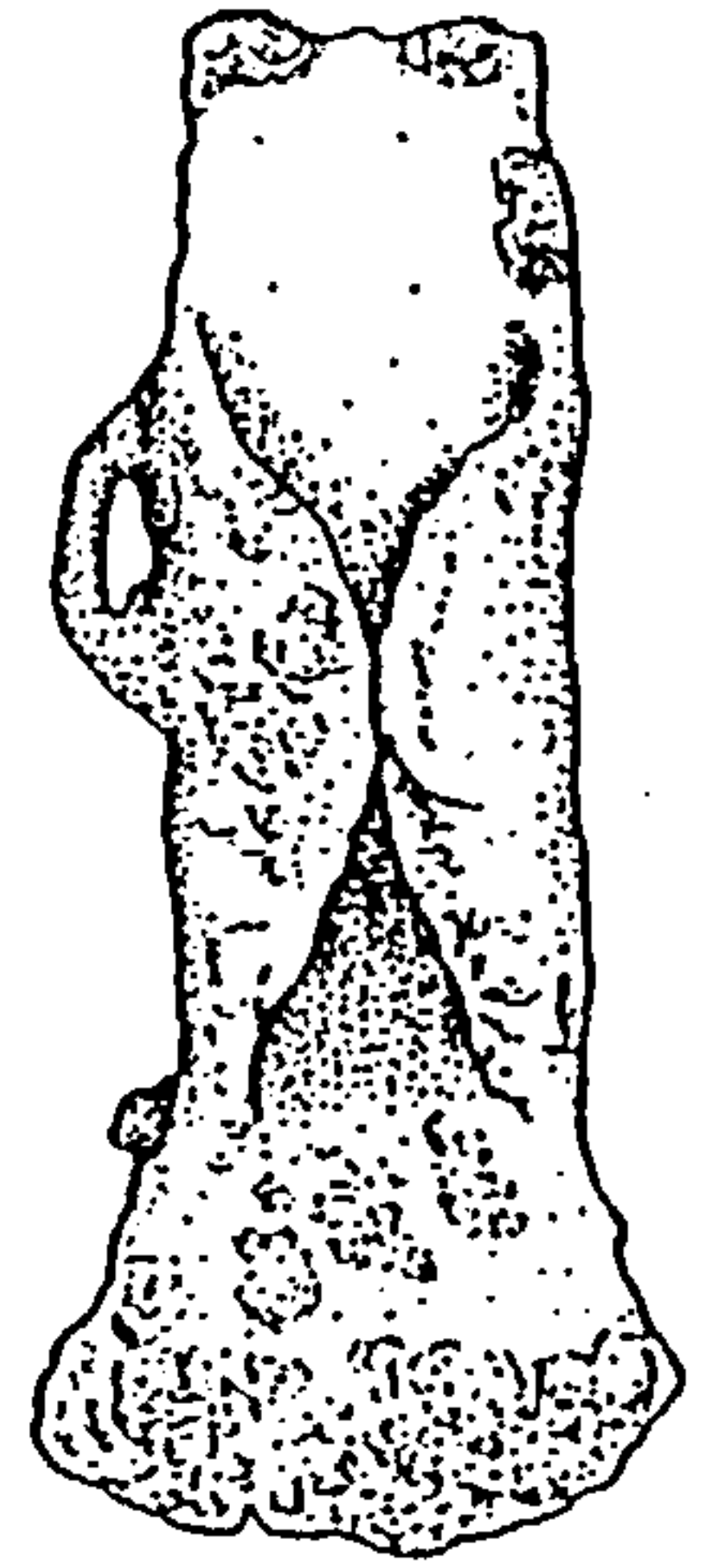
20/72



20/73

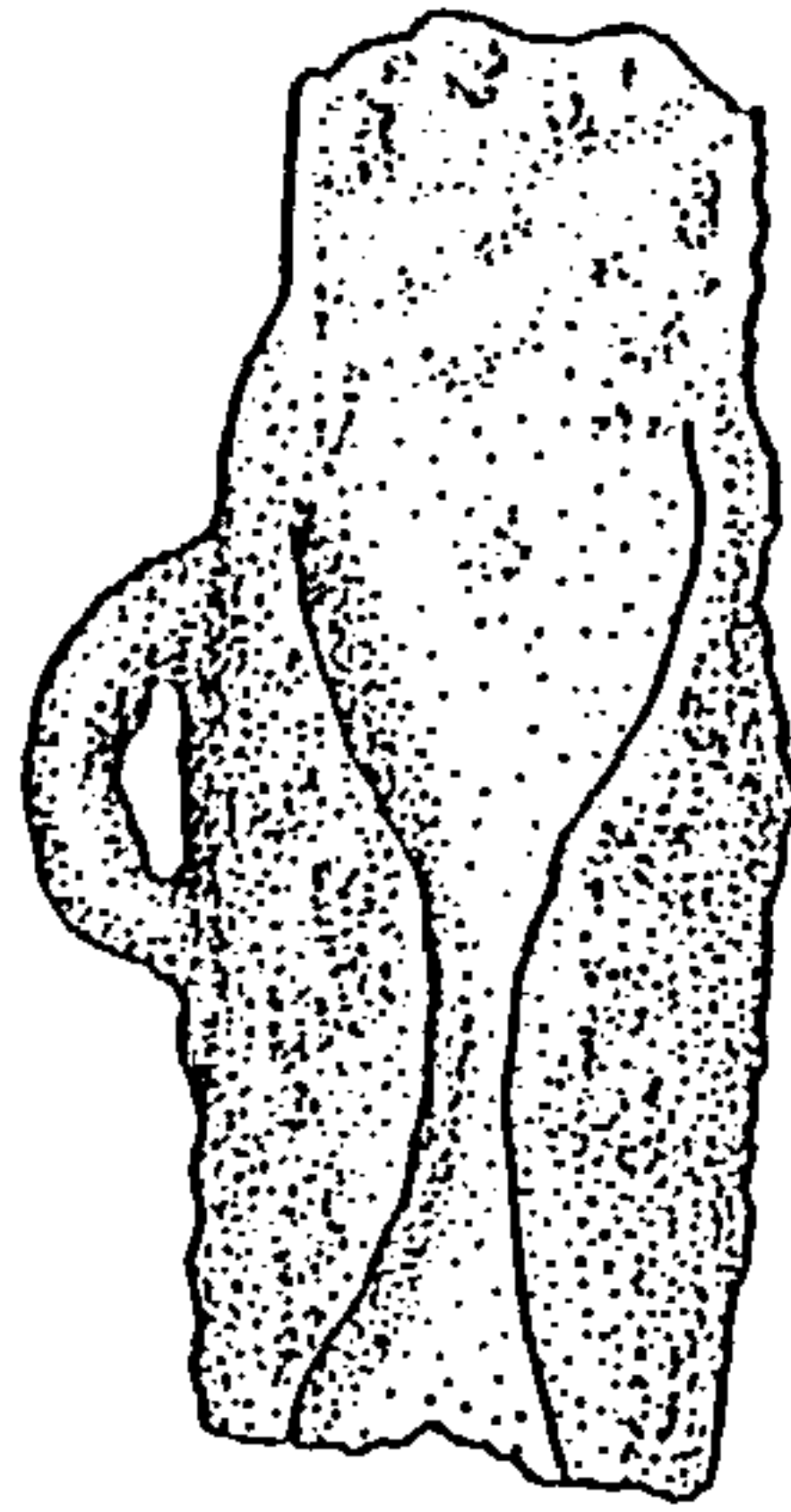


20/74



0 2cm

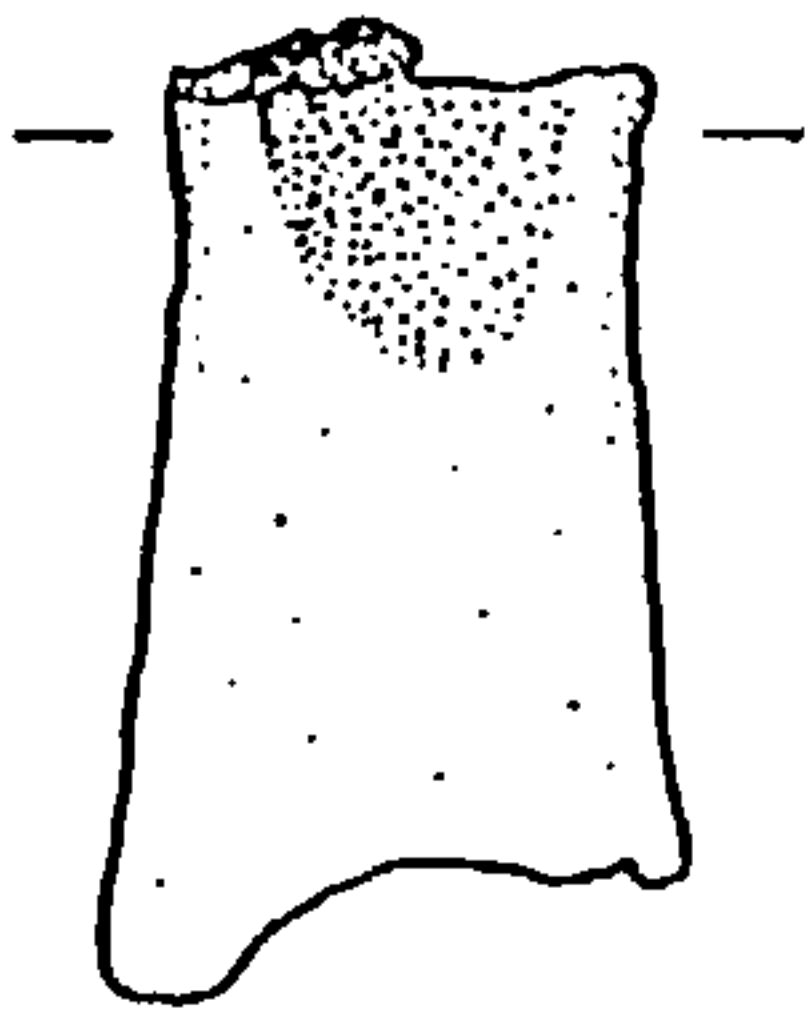
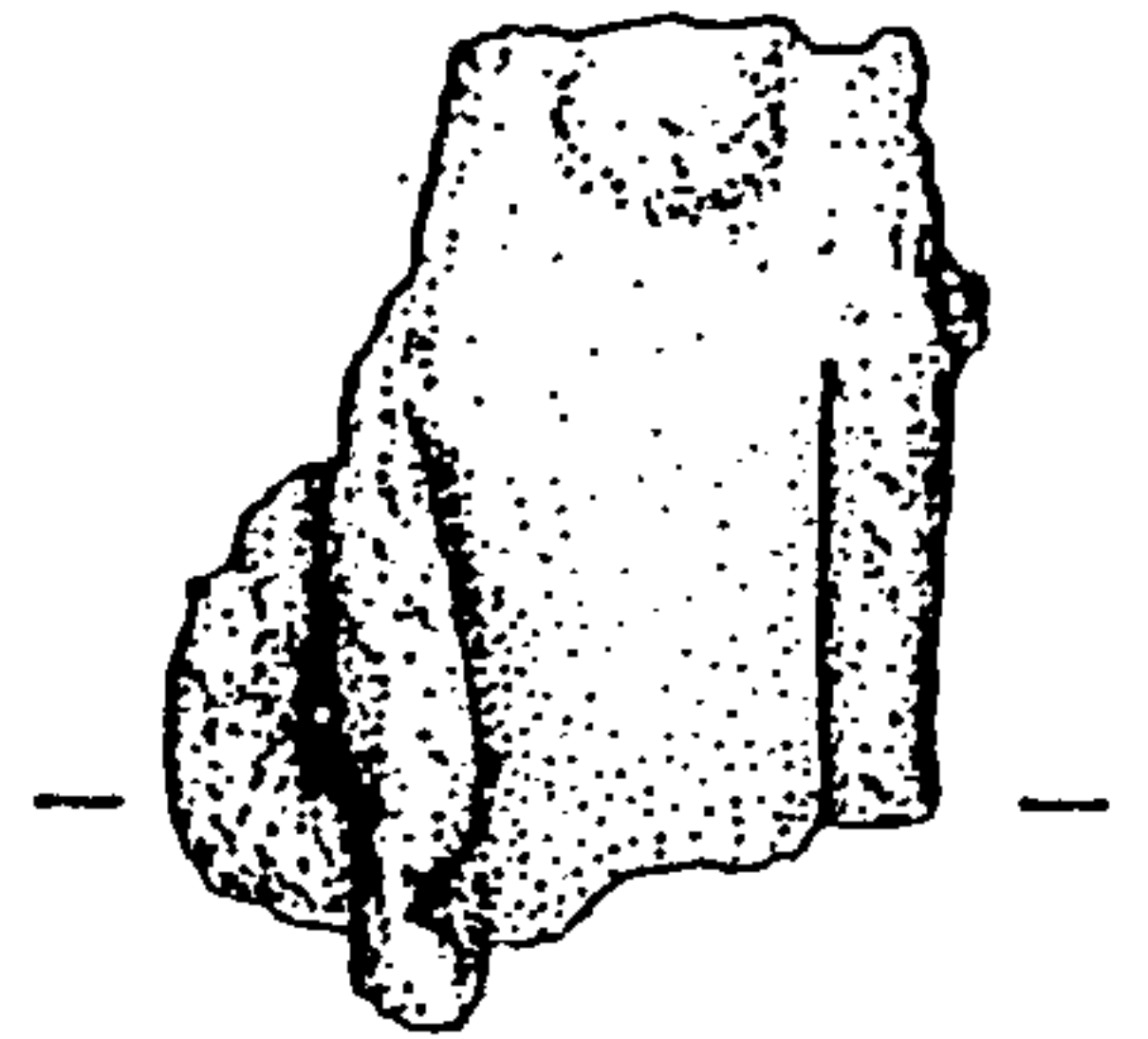
20/75



20/76



20/77



20/78



20/79

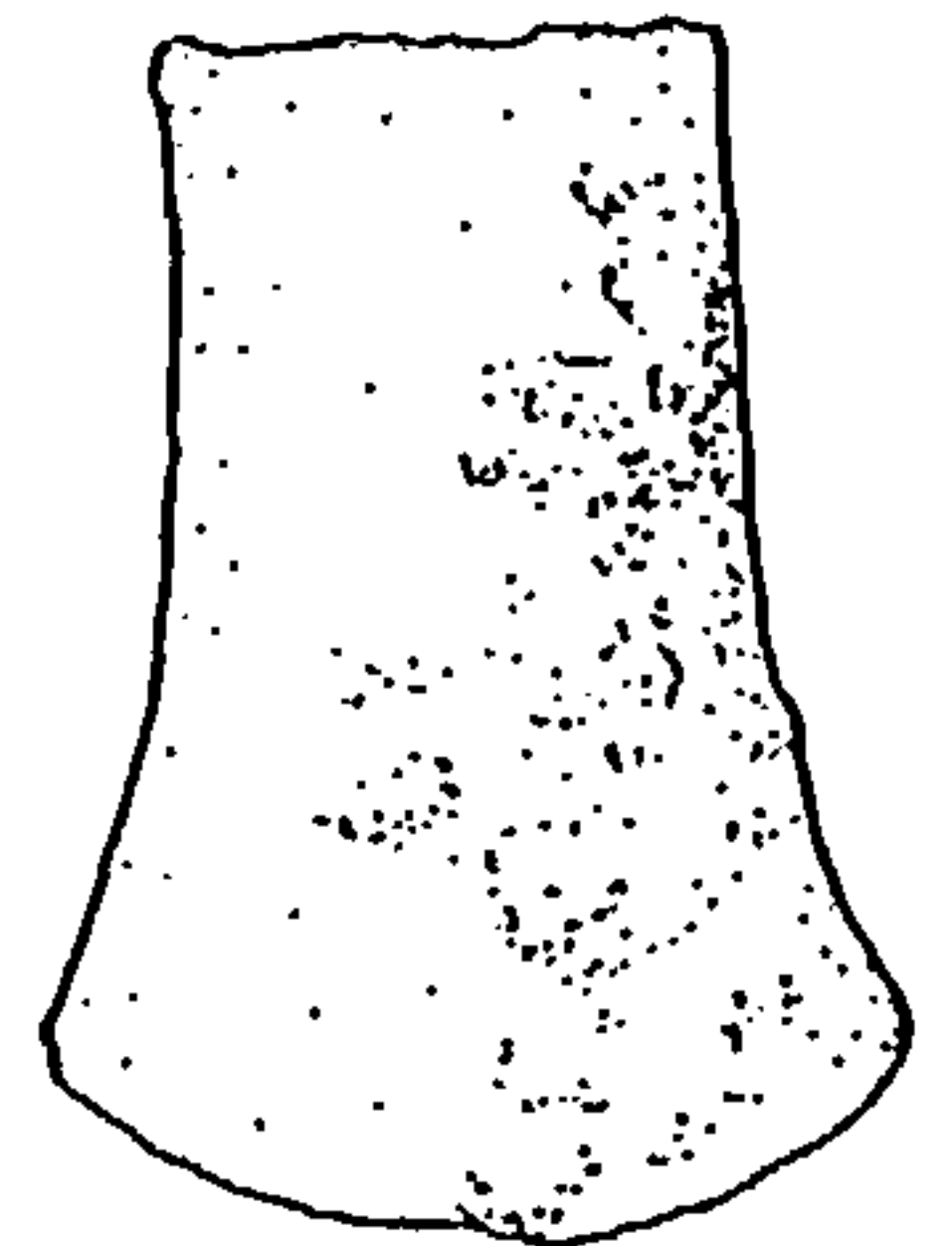
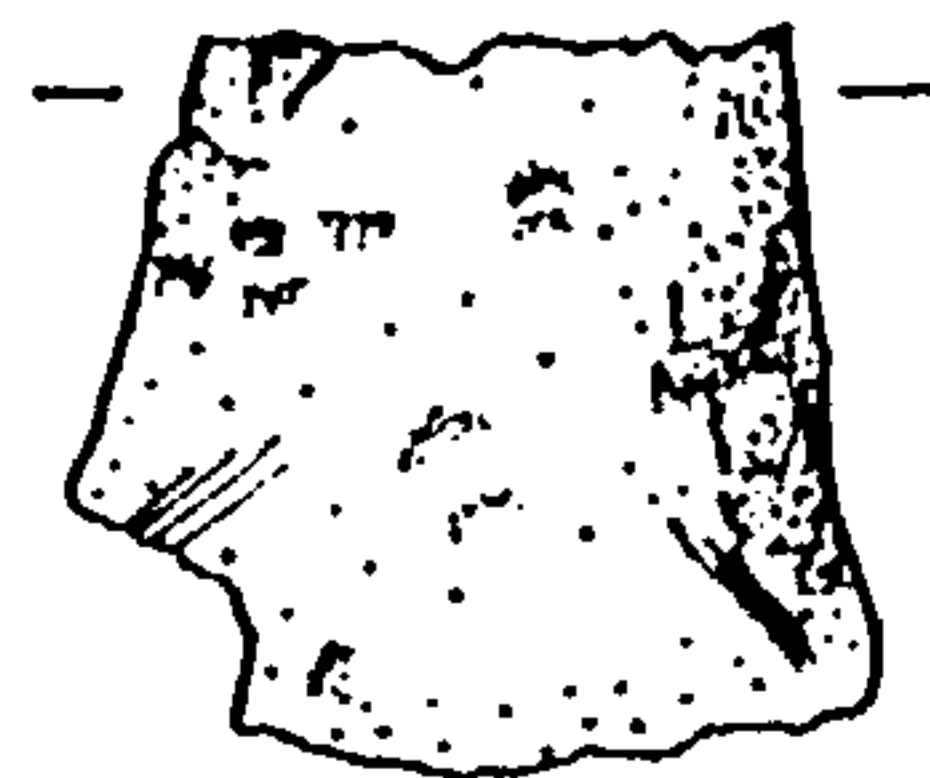
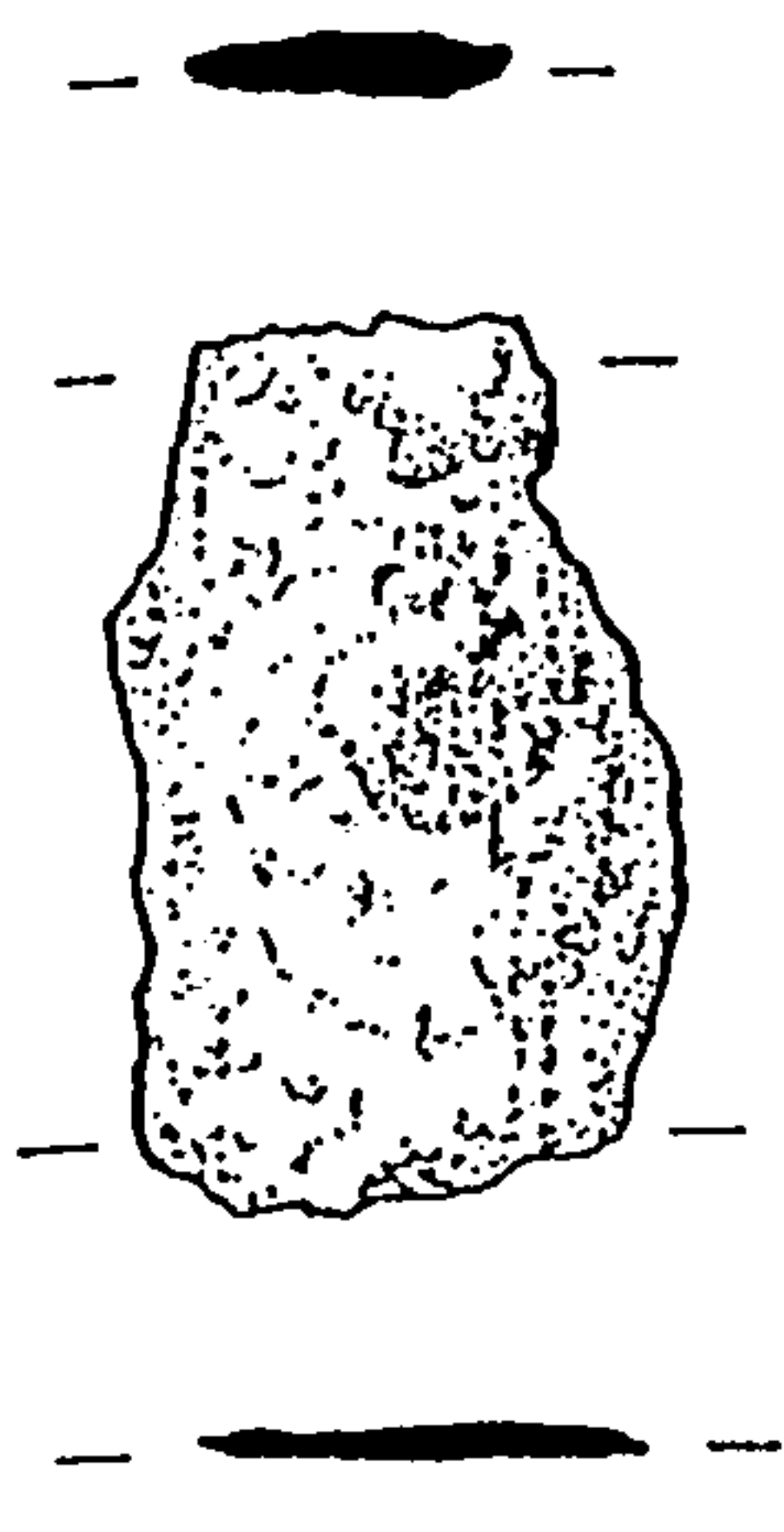
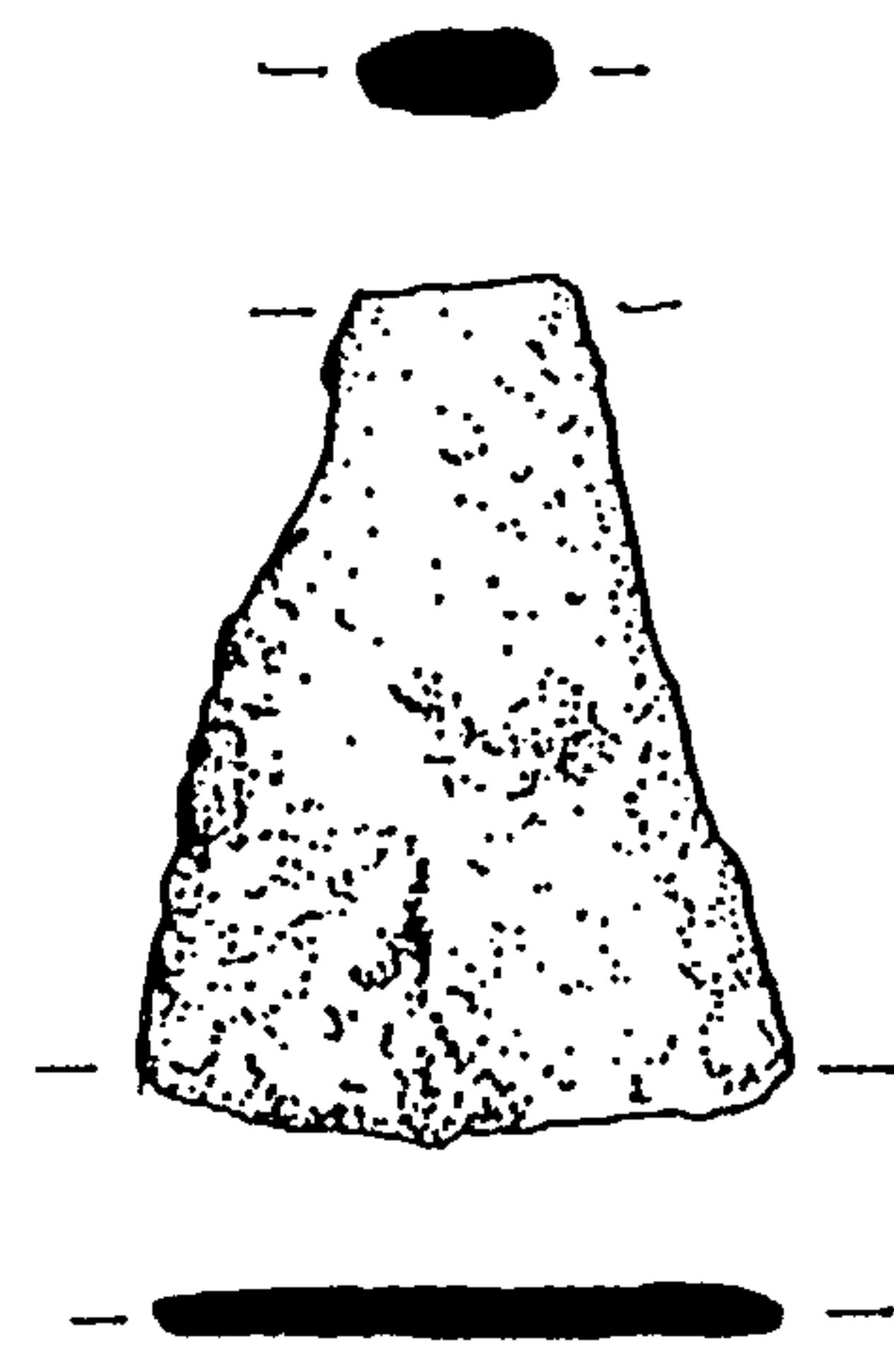


Fig. 64: The Minster Hoard (Ref. No. 20): Winged Axes (ii)

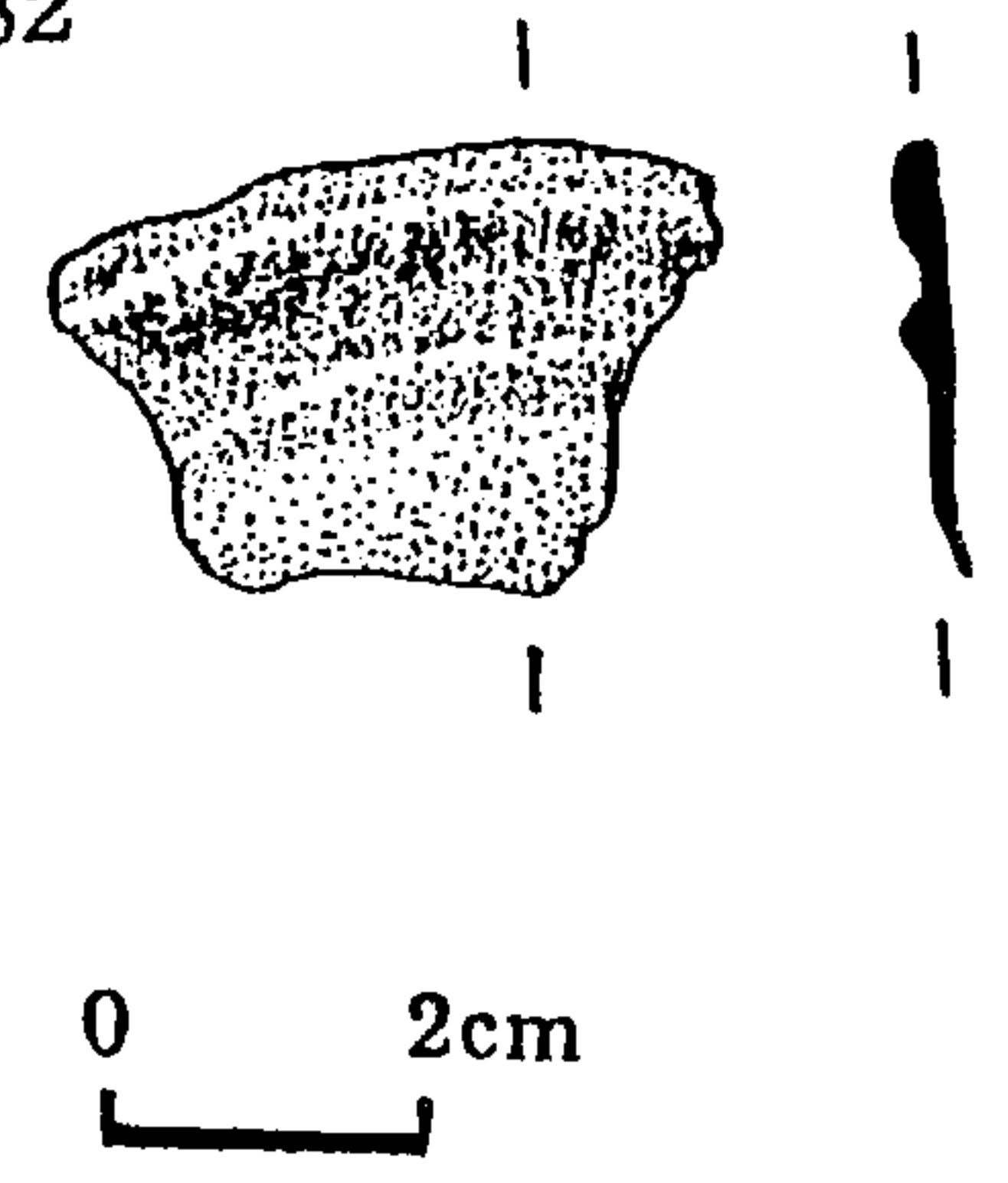
20/80



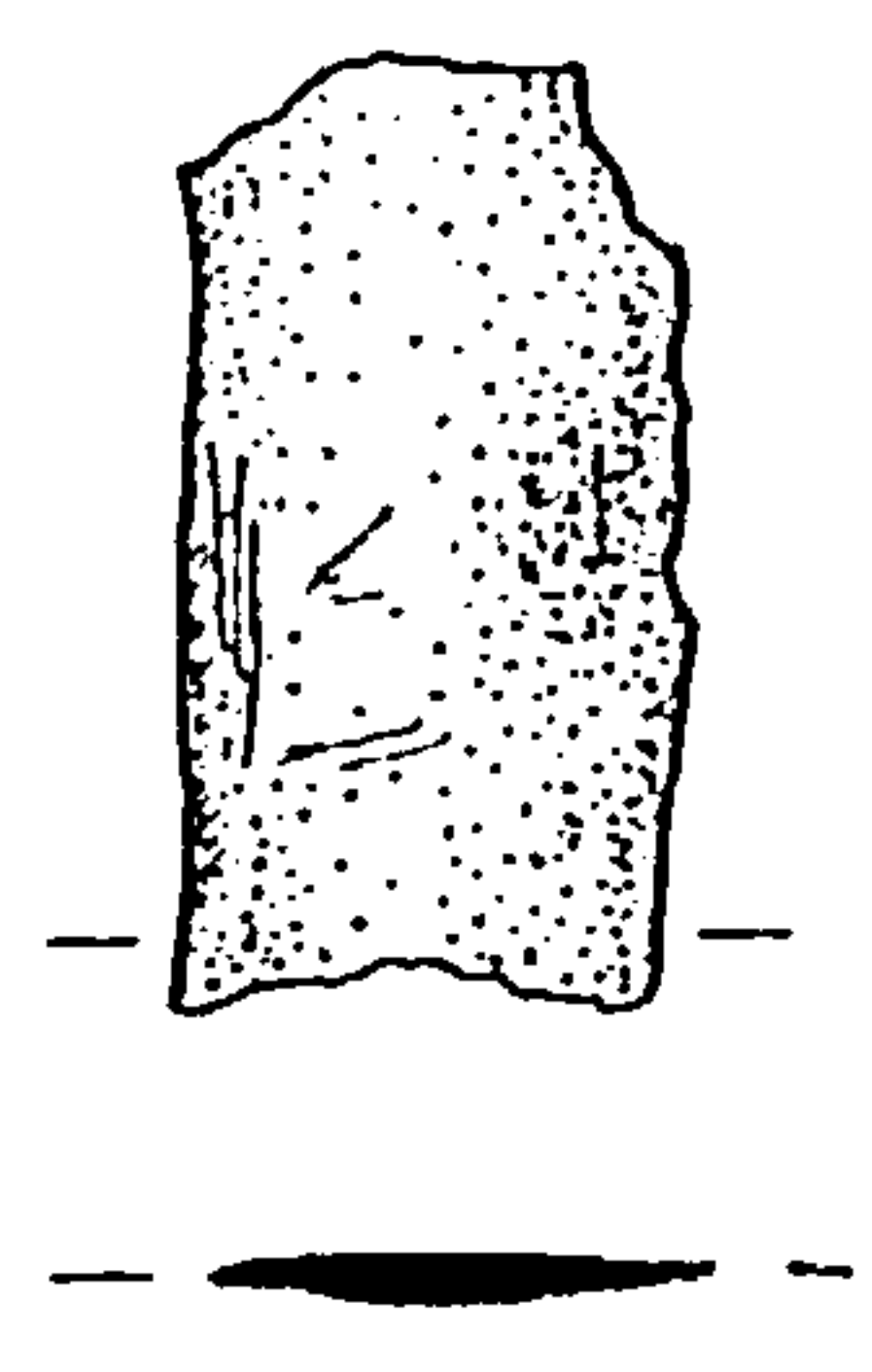
20/81



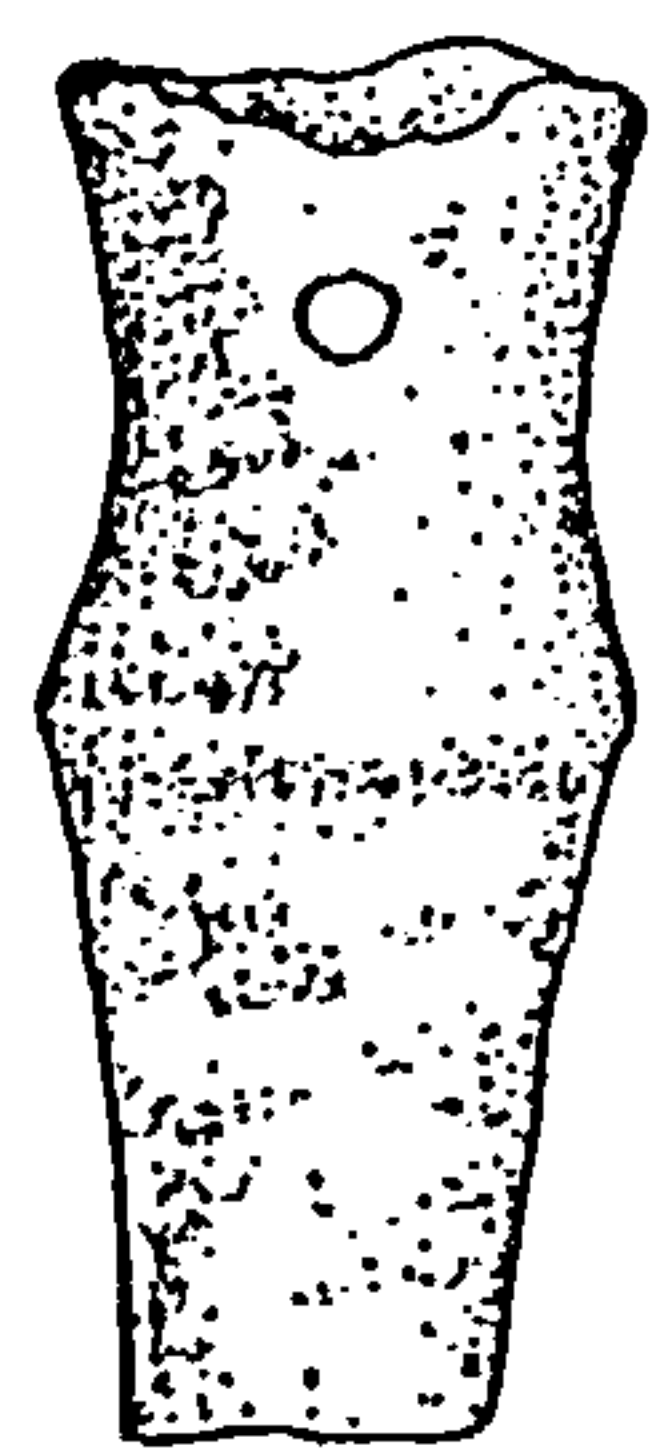
20/82



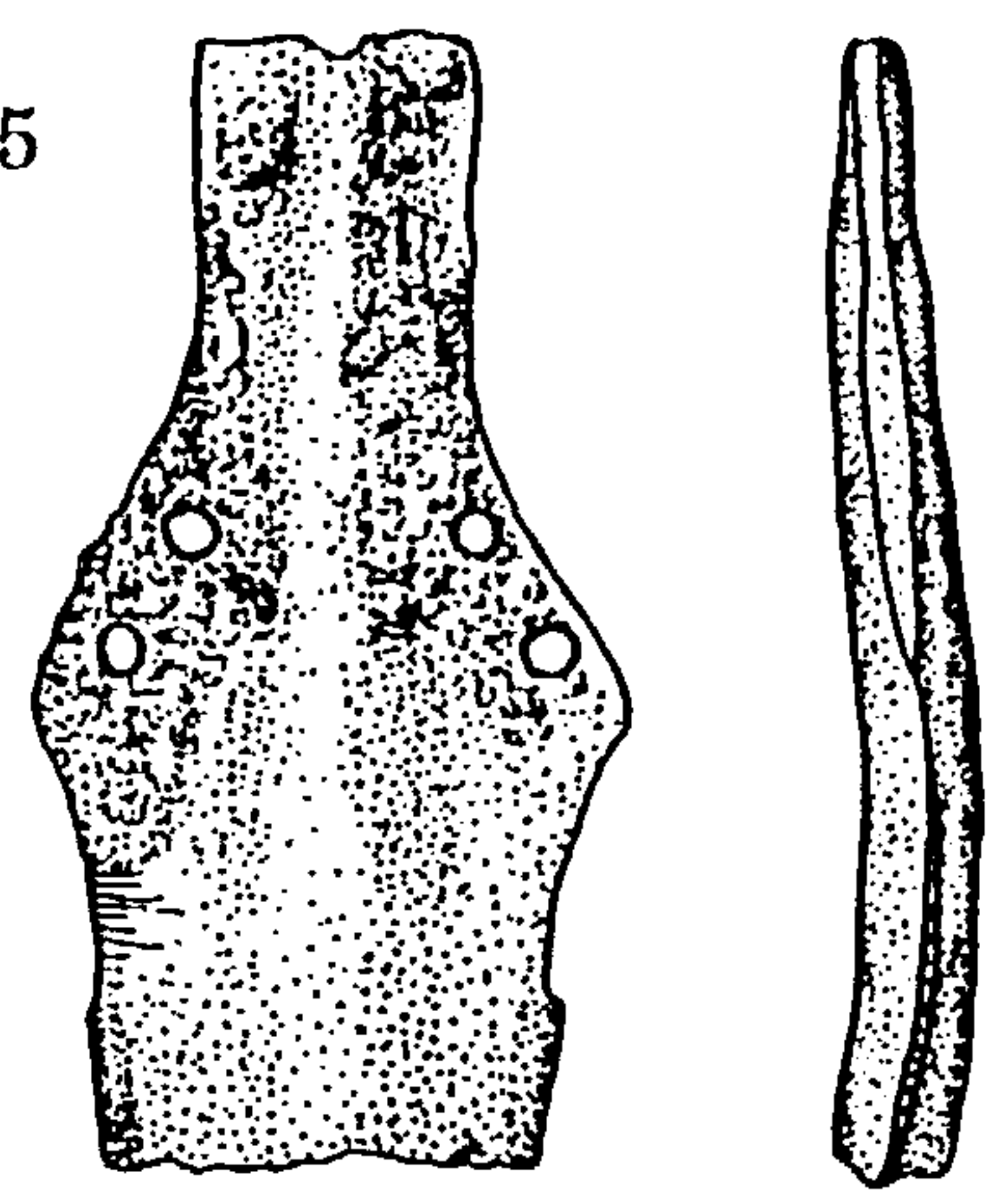
20/83



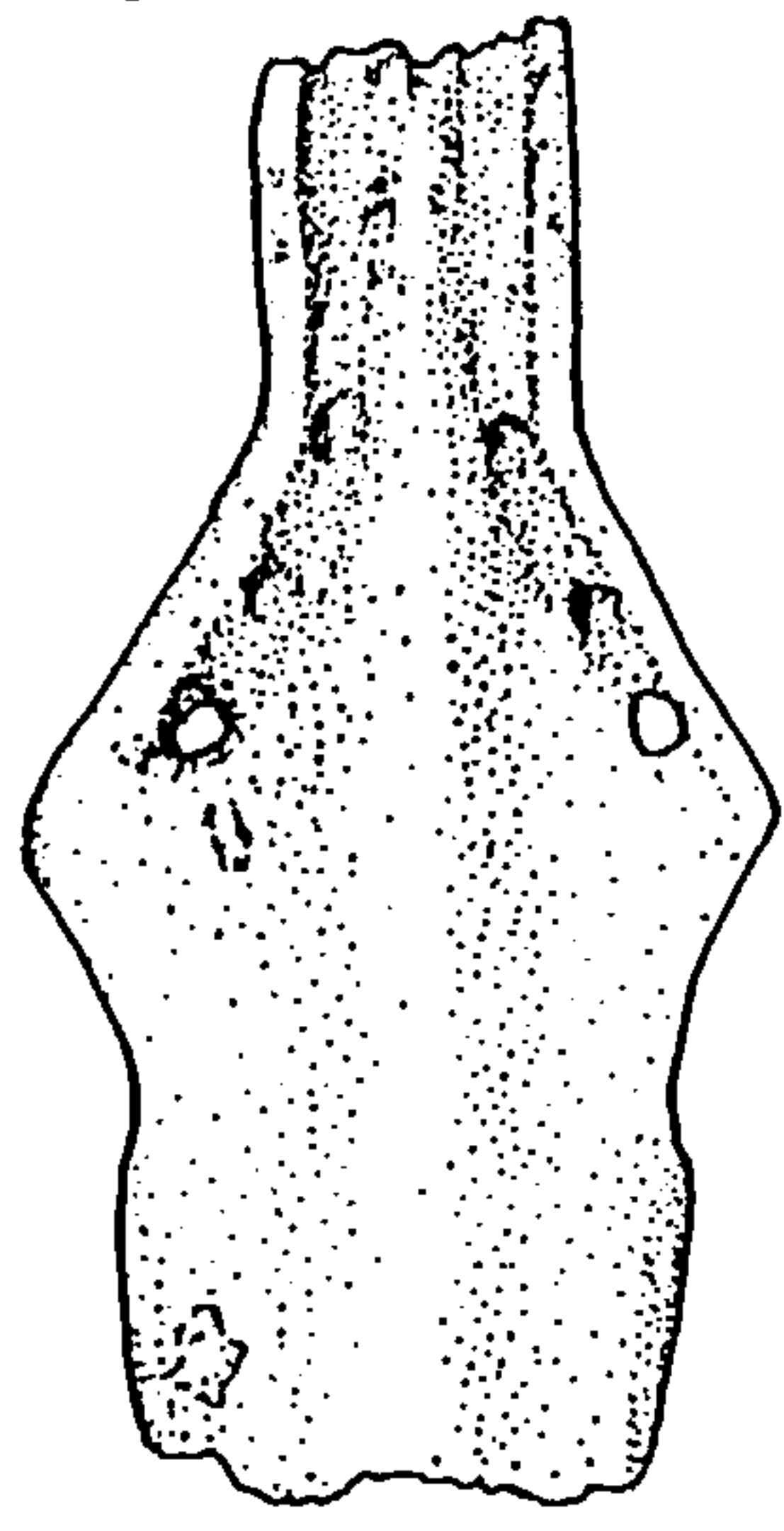
20/84



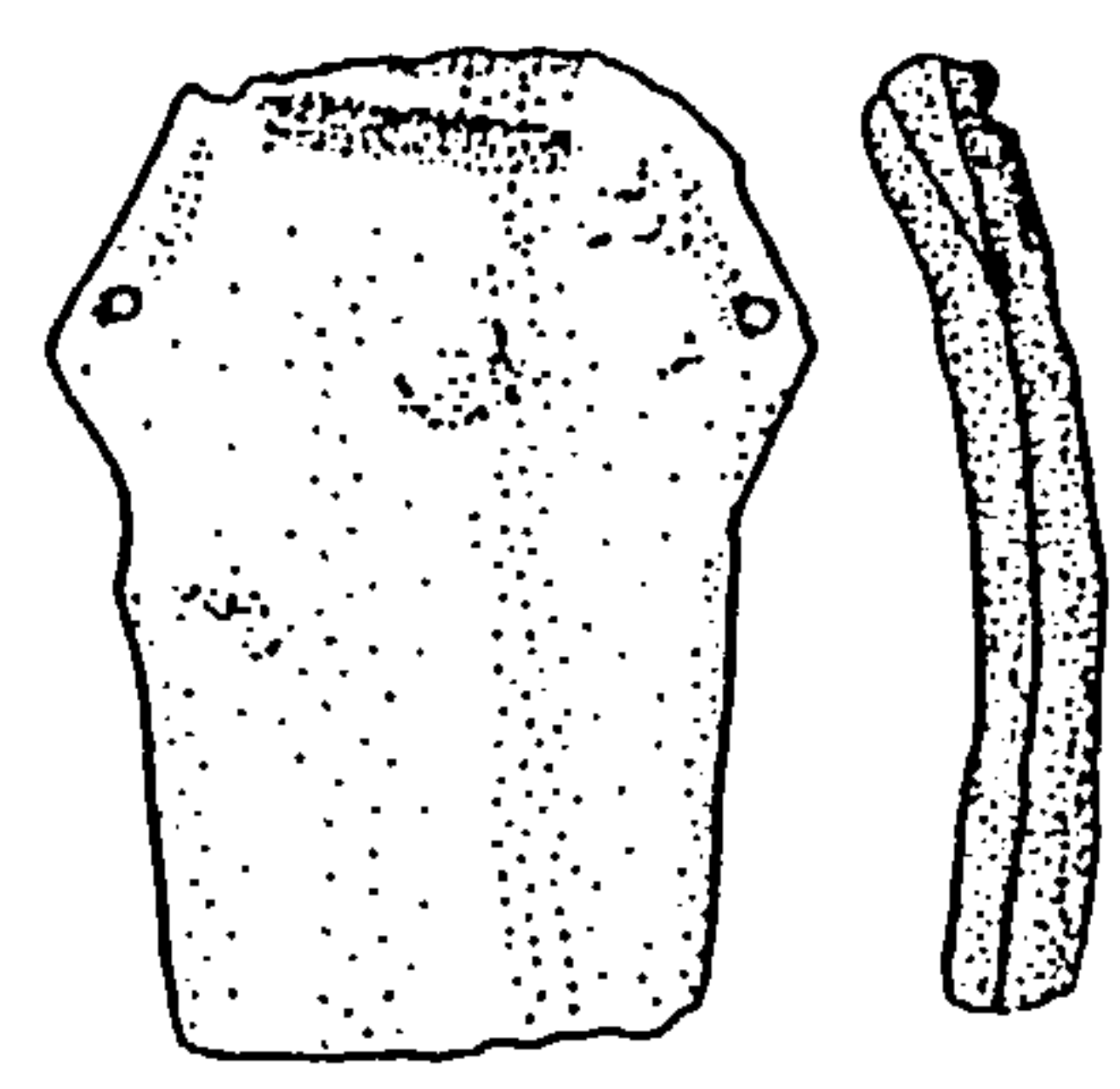
20/85



20/86



20/87



20/88

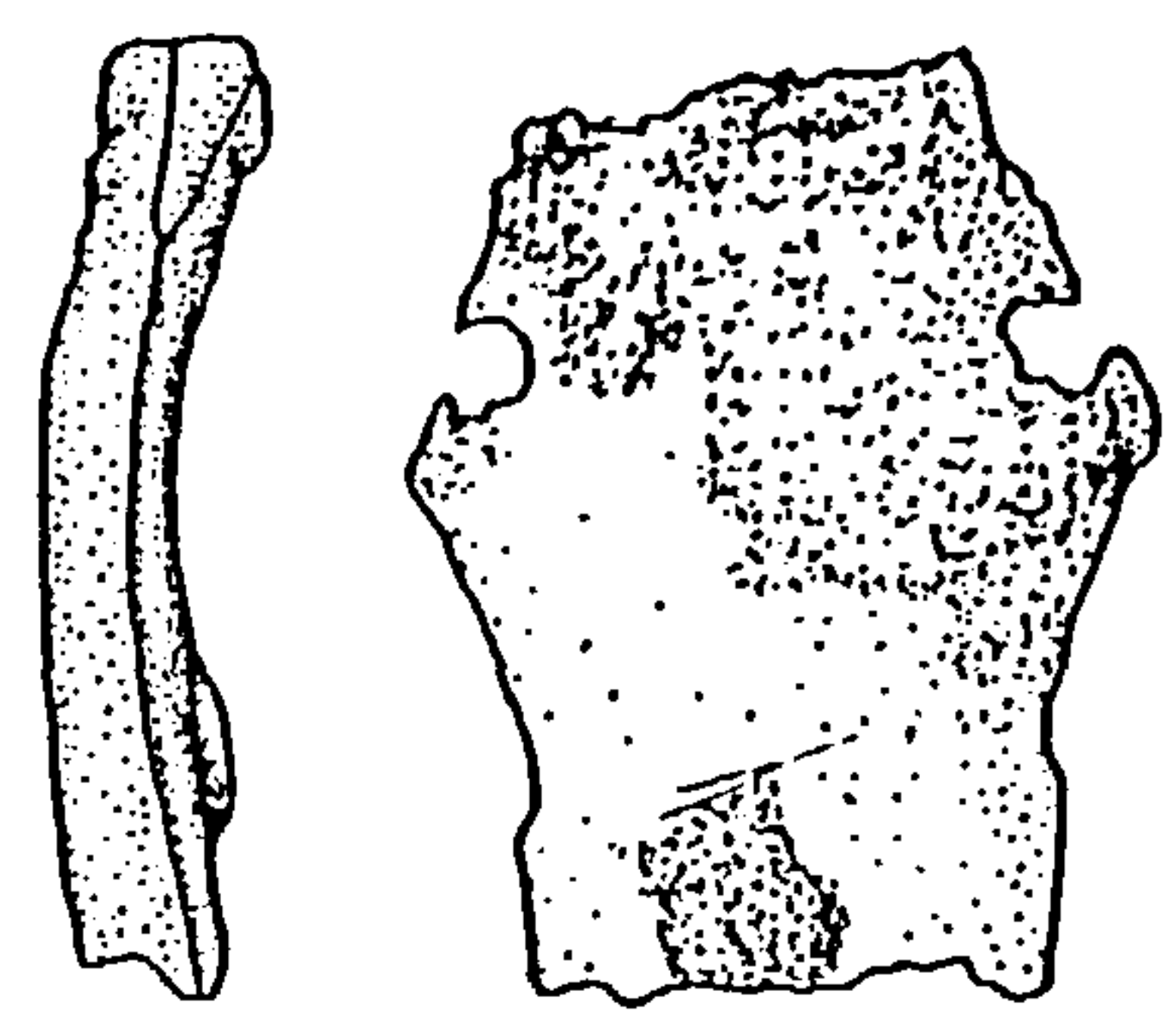
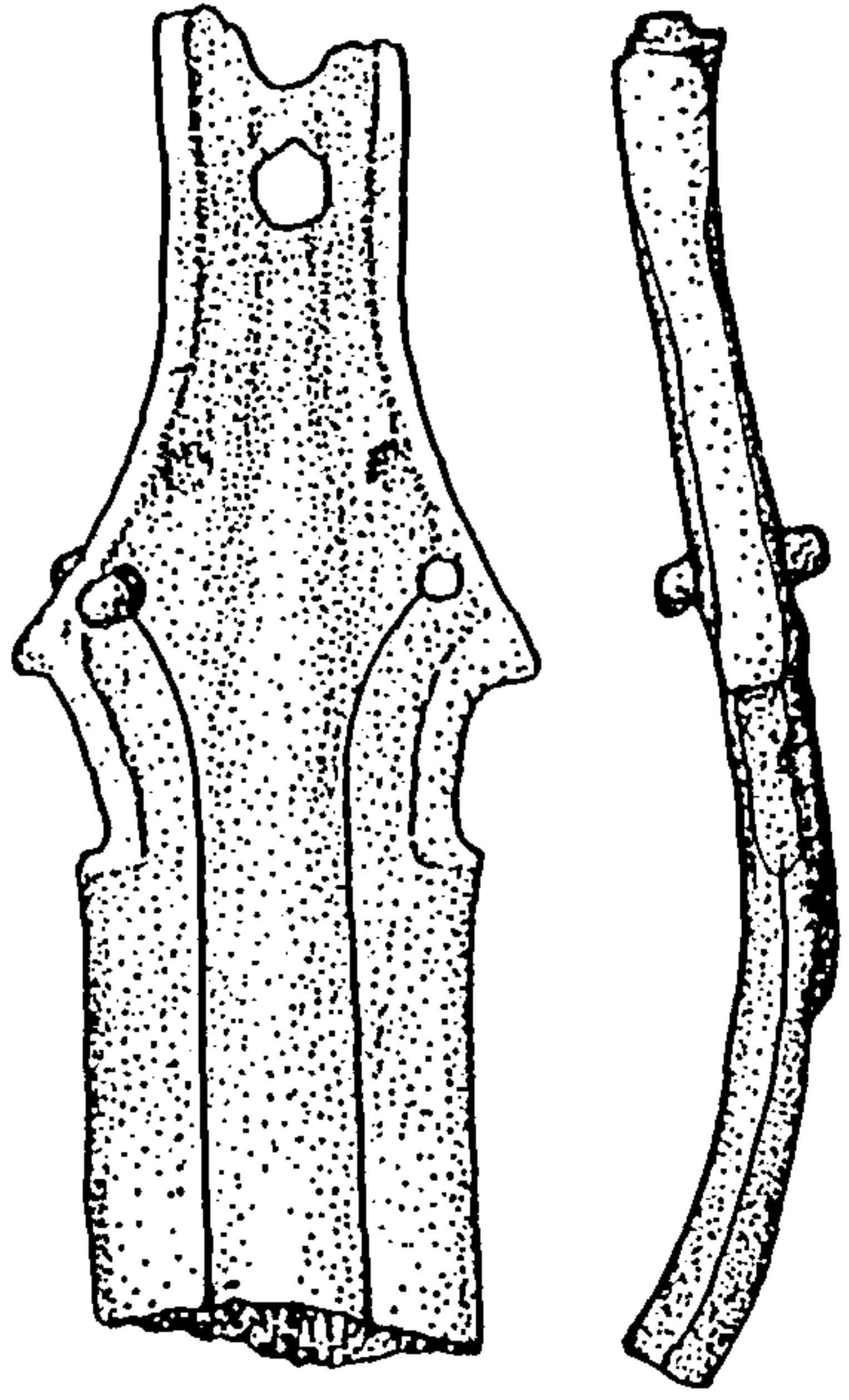
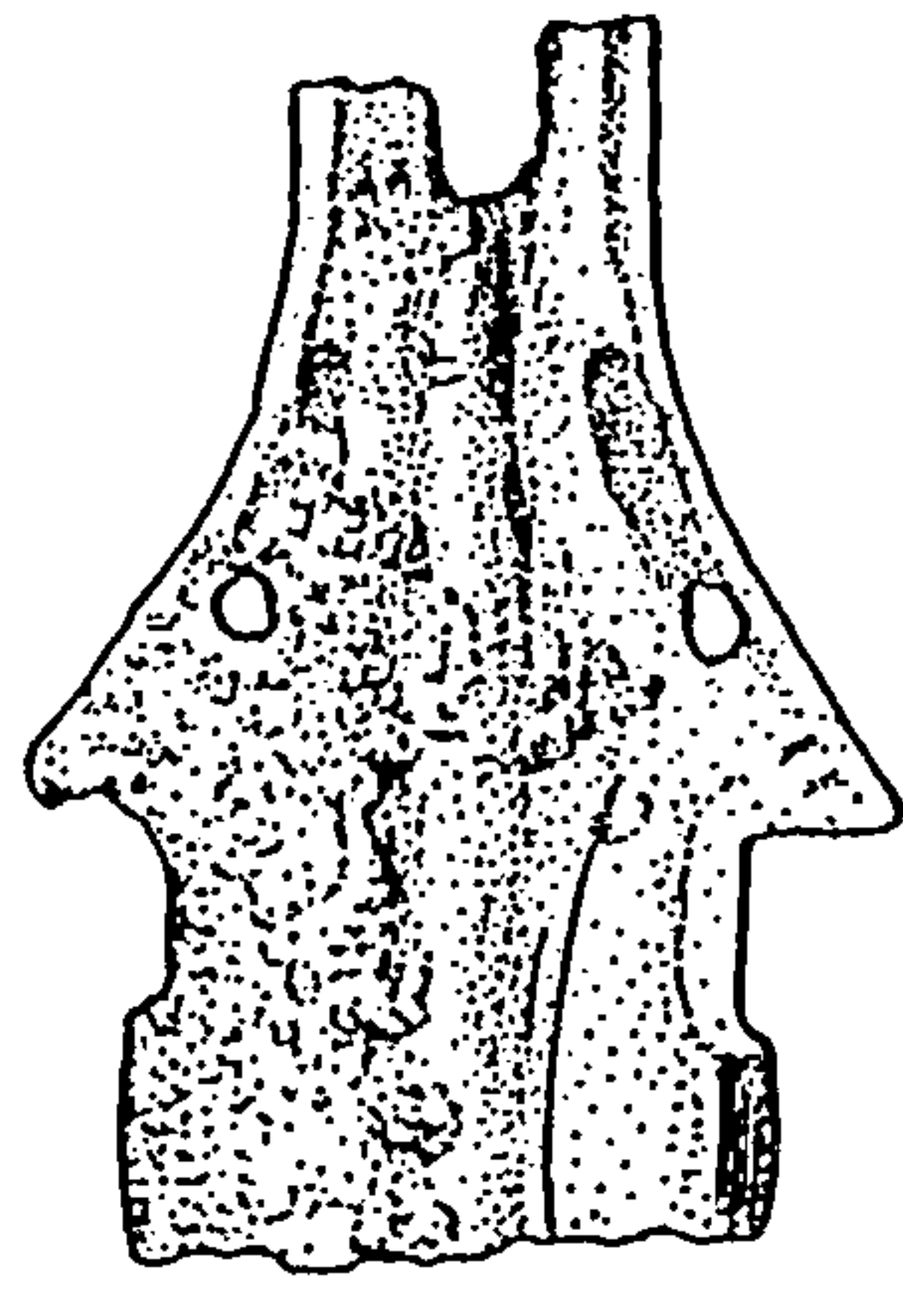


Fig. 65: The Minster Hoard (Ref. No. 20): Small Tools and Sword Fragments

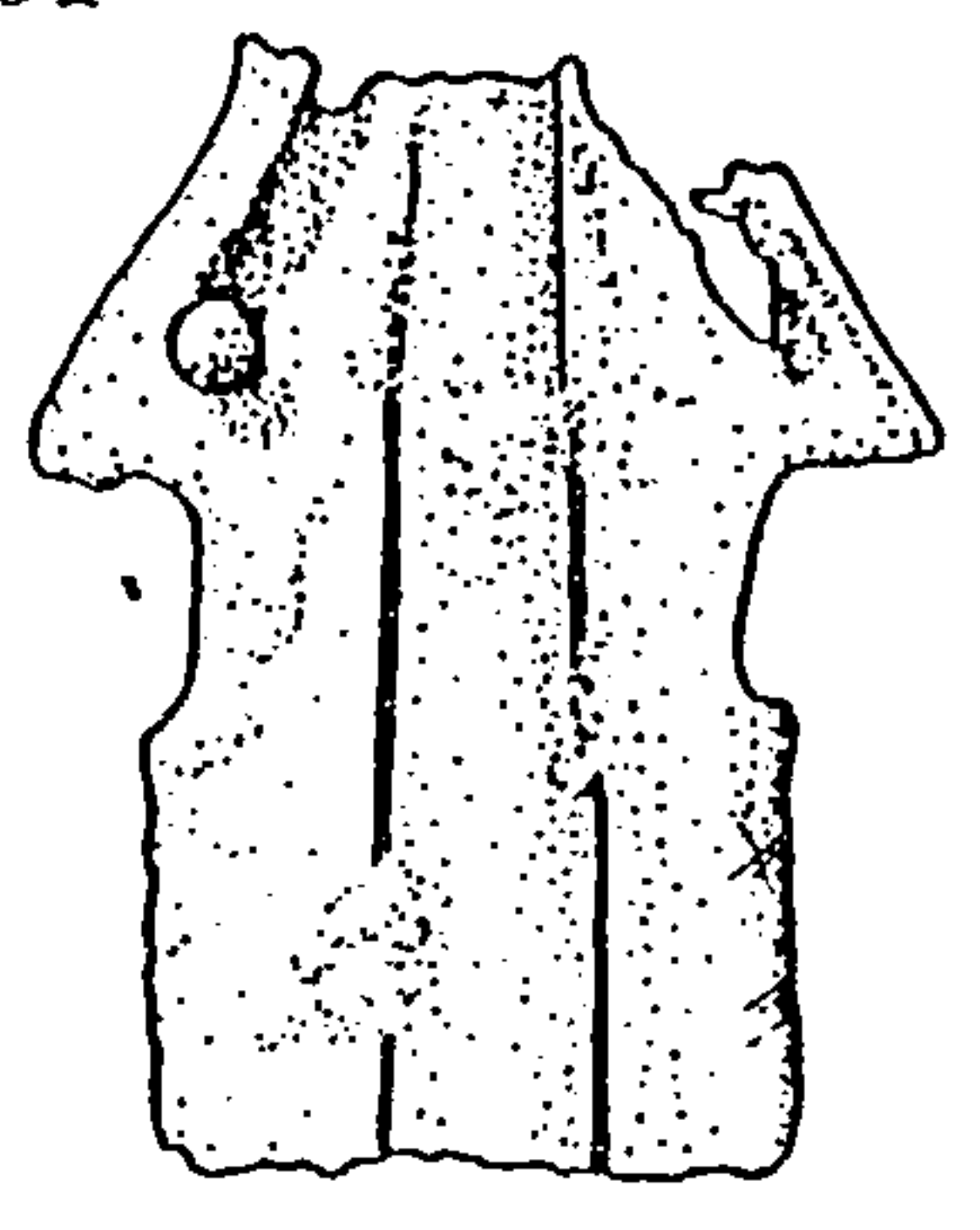
20/89



20/90

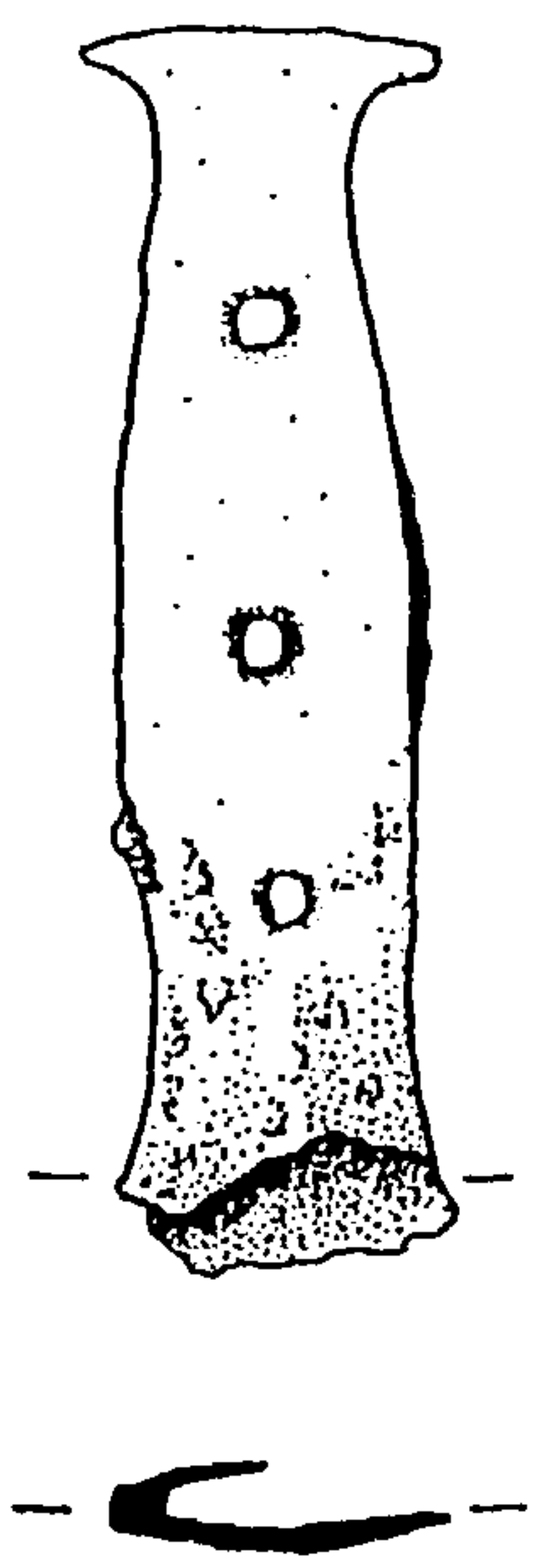


20/91

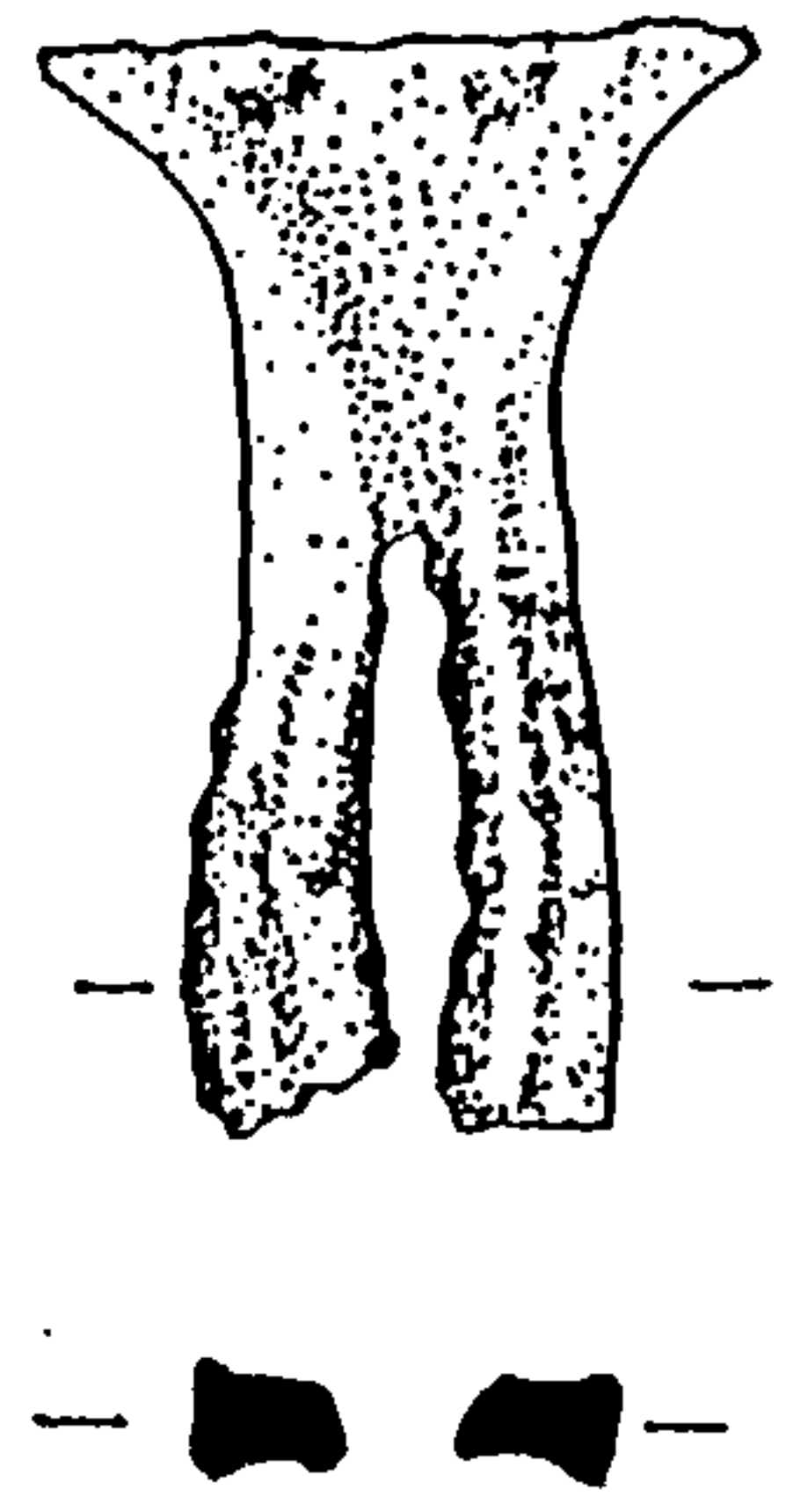


0 2cm

20/92



20/93



20/94

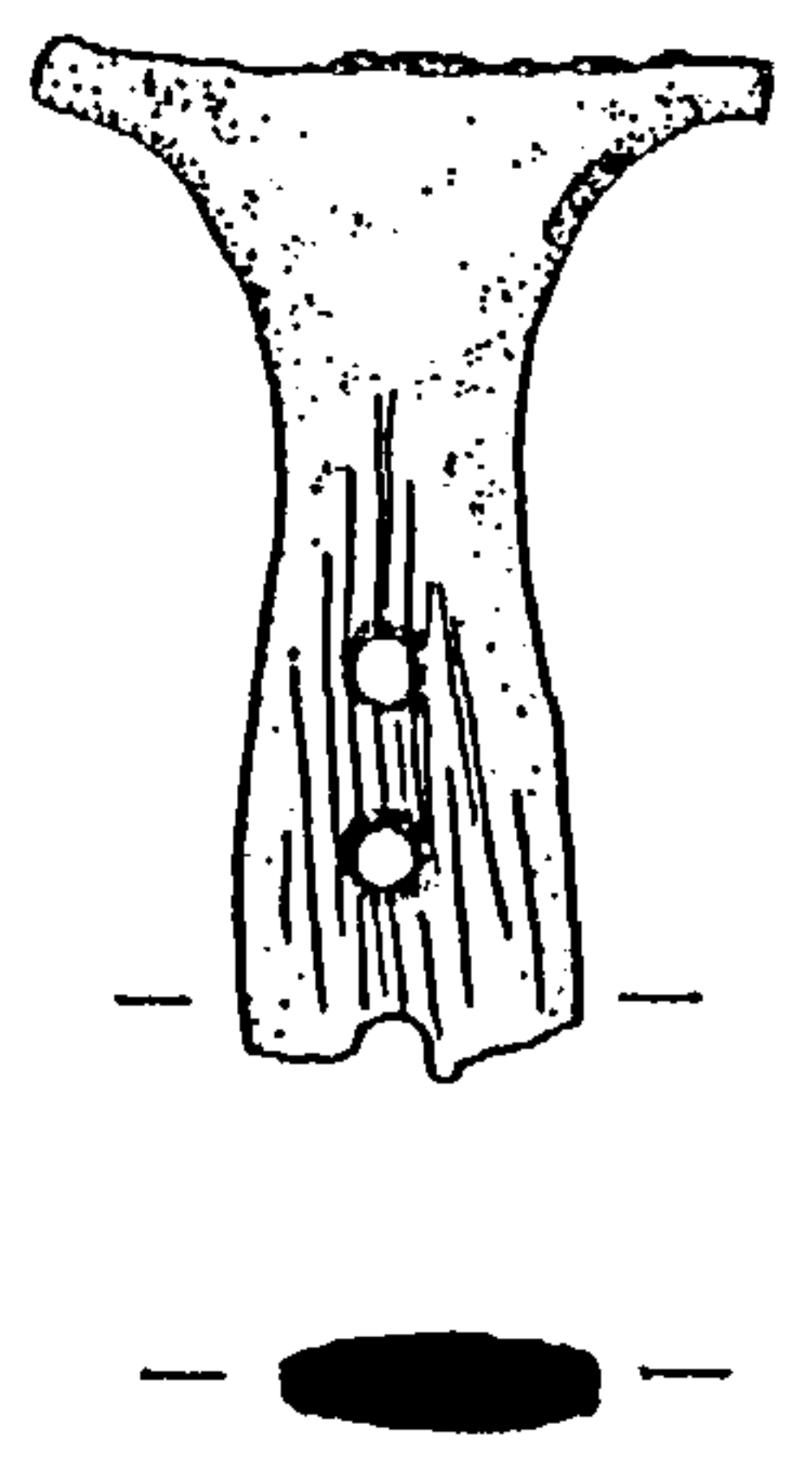
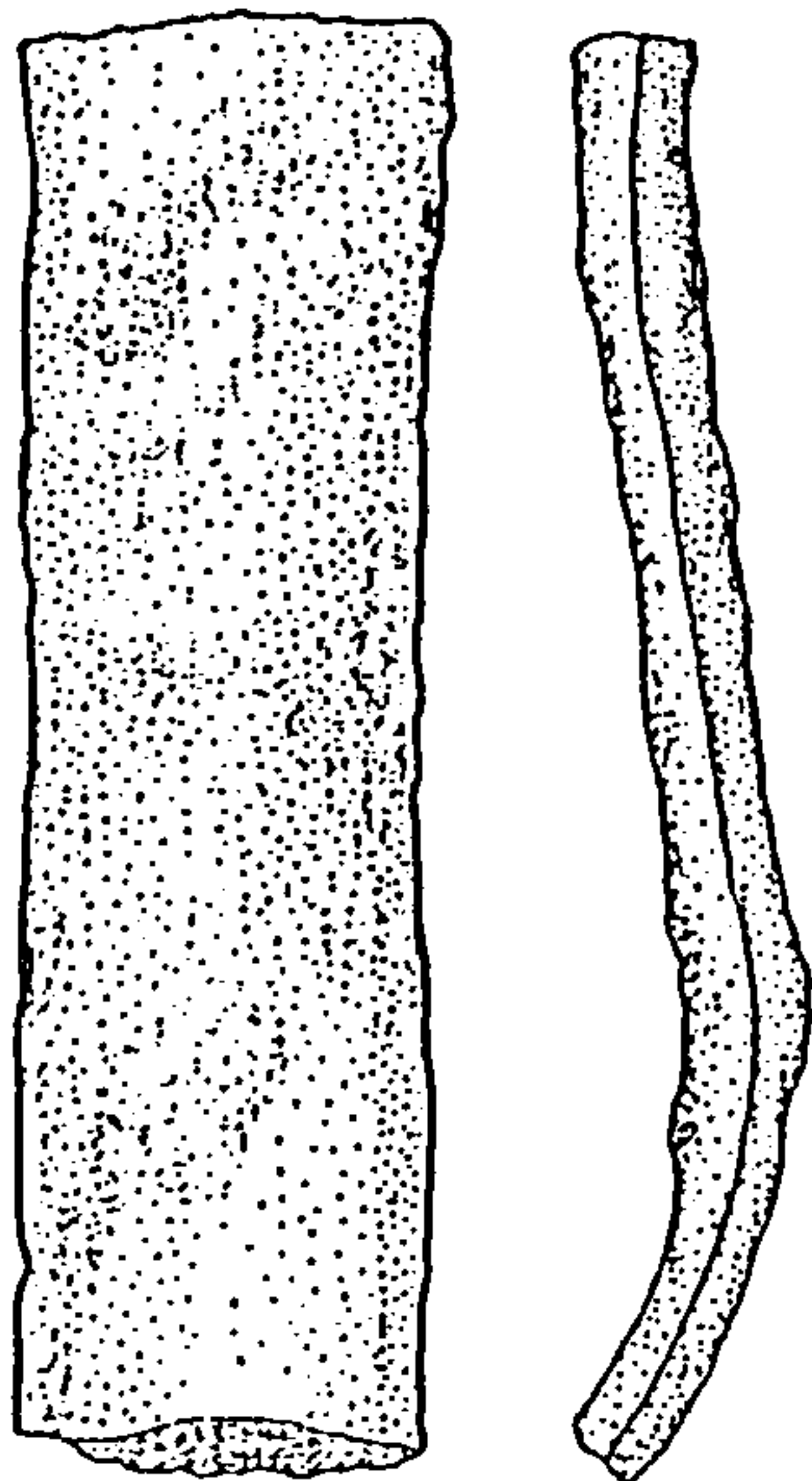
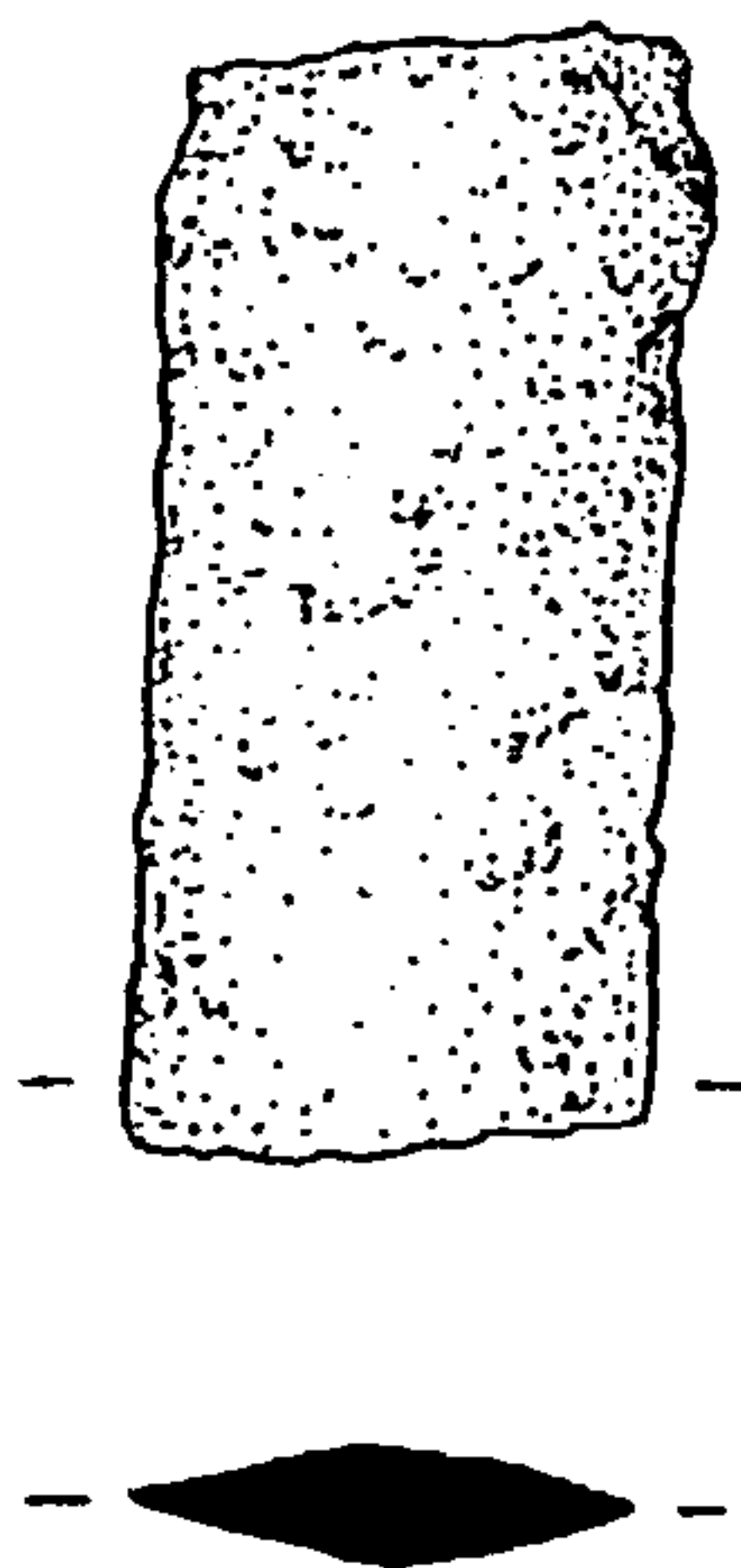


Fig. 66: The Minster Hoard (Ref. No. 20): Sword Hilt Fragments

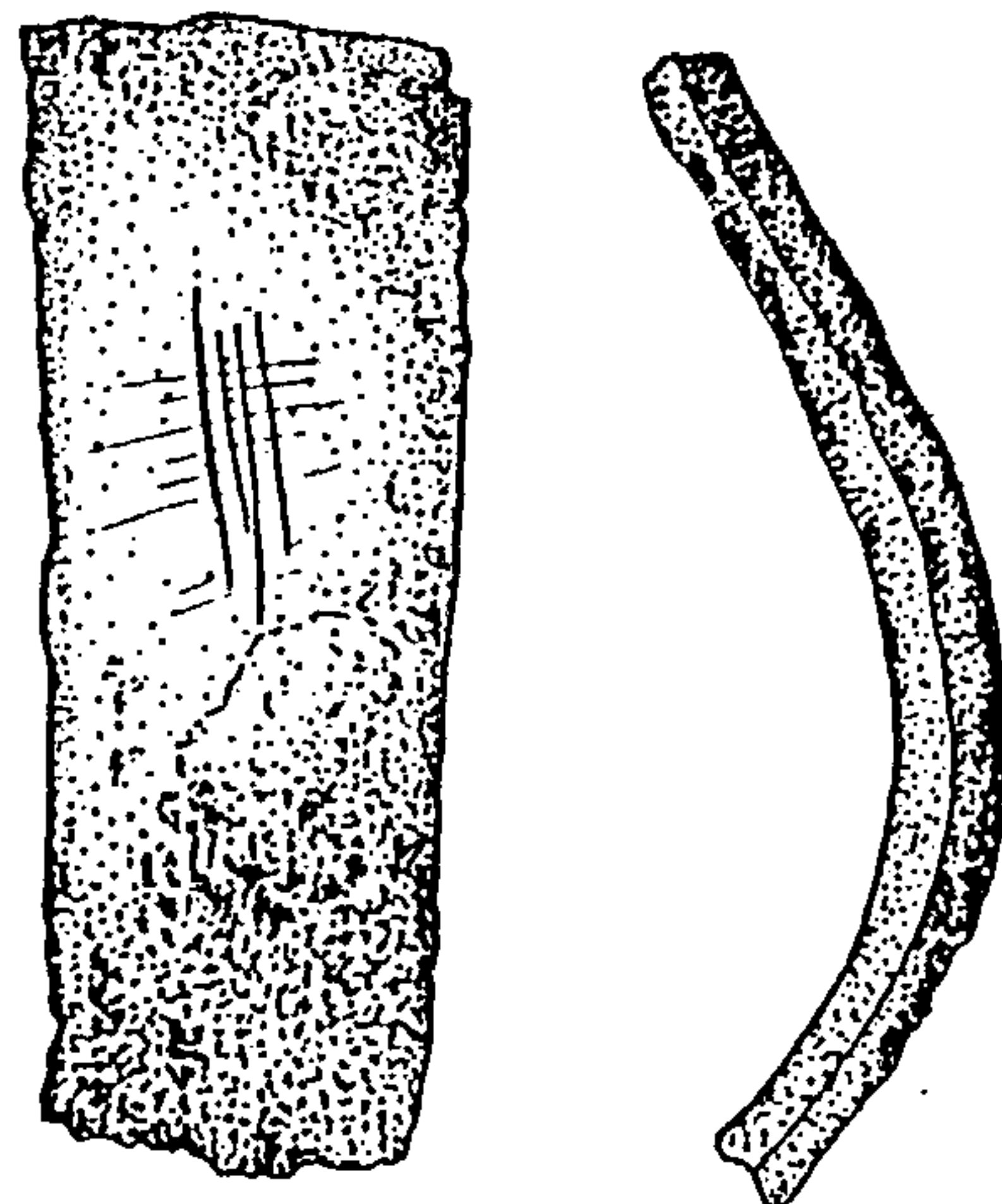
20/95



20/96

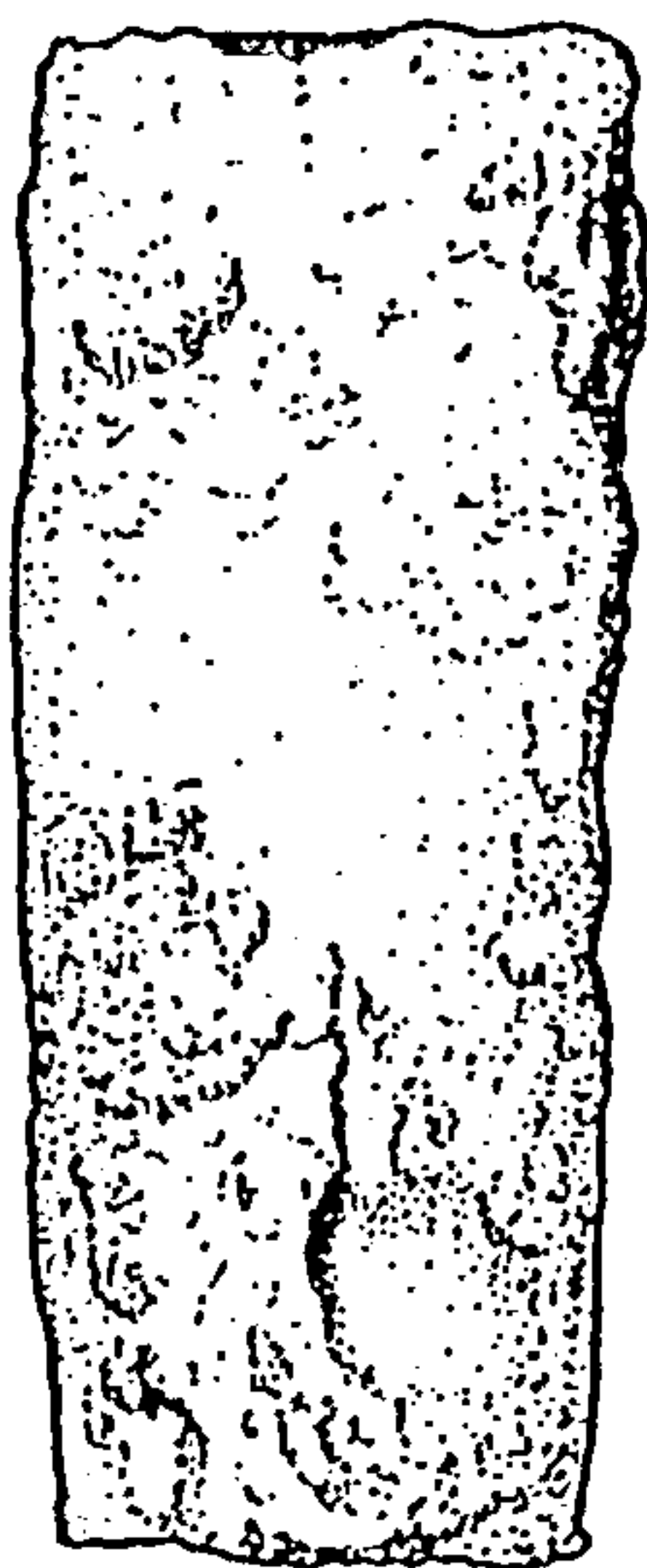


20/97



0 2cm

20/98



20/99



20/100

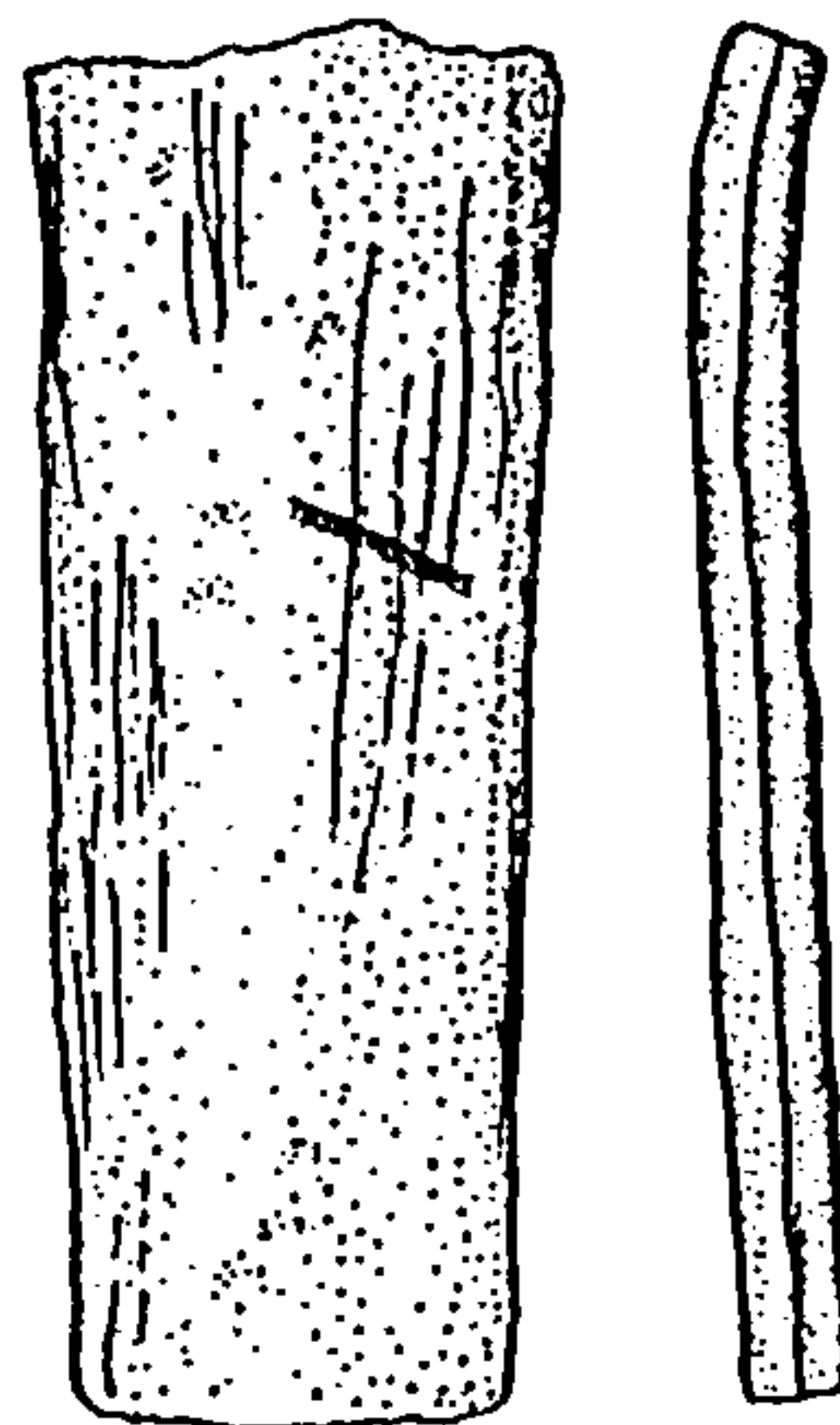
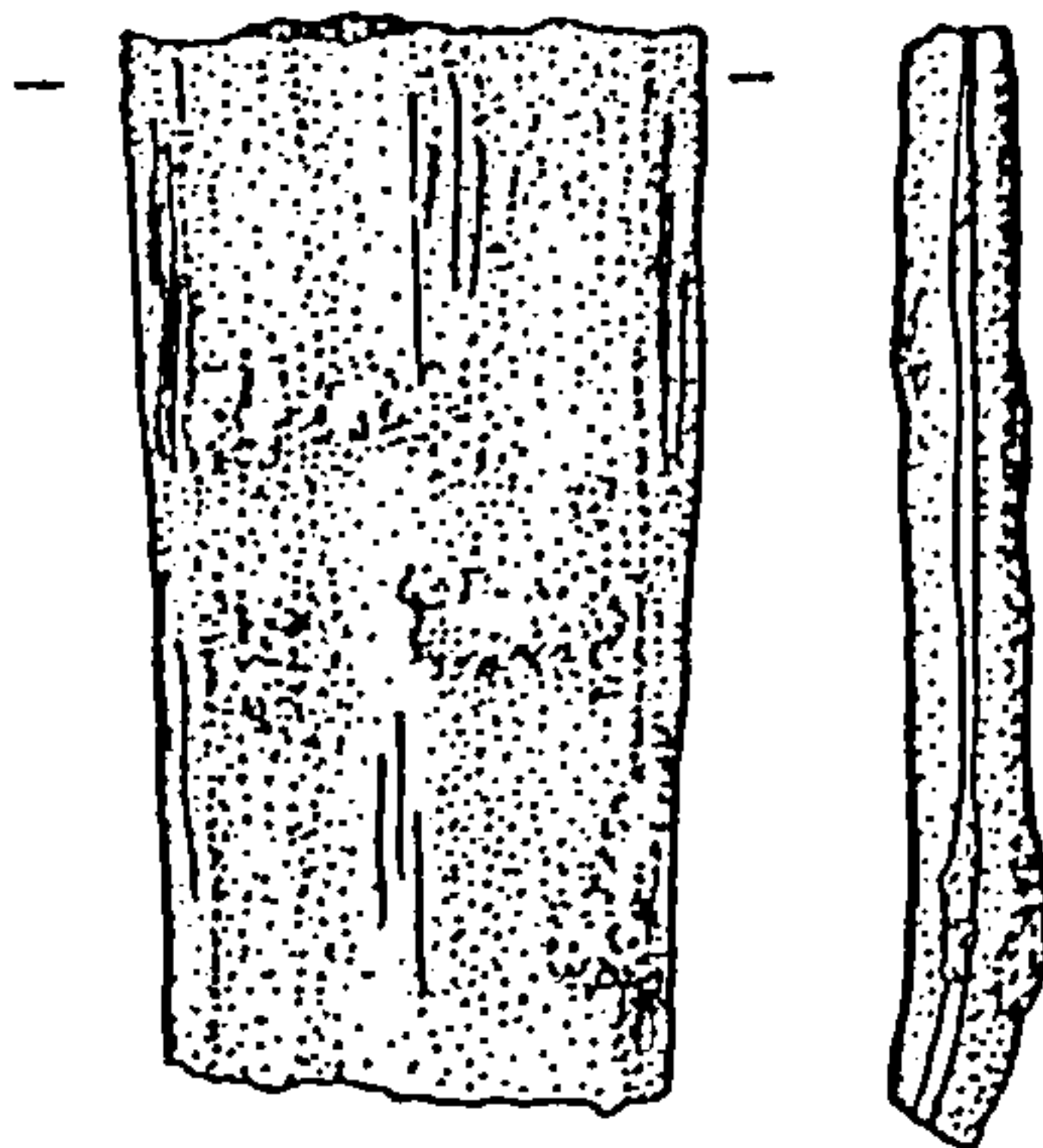
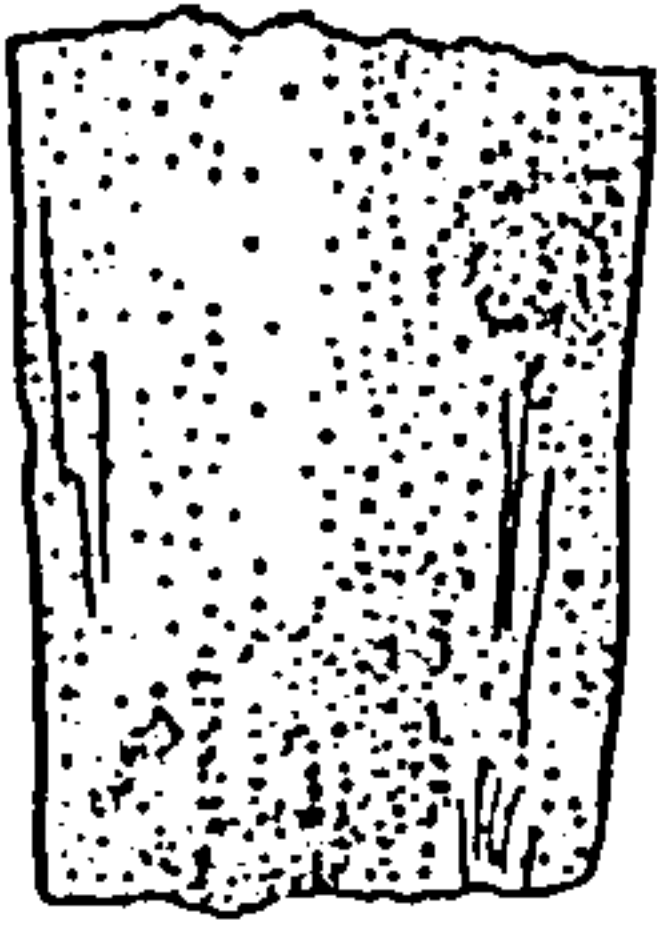
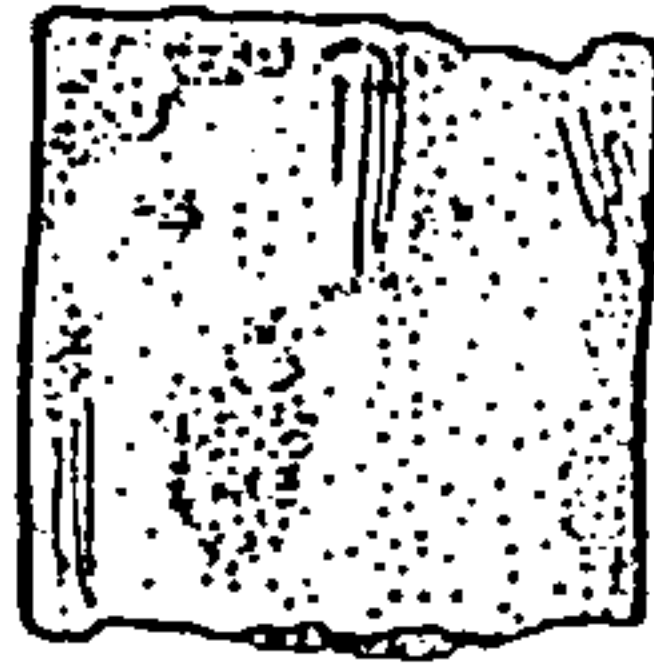


Fig. 67: The Minster Hoard (Ref. No. 20): Ewart Park Sword Blade Fragments (i)

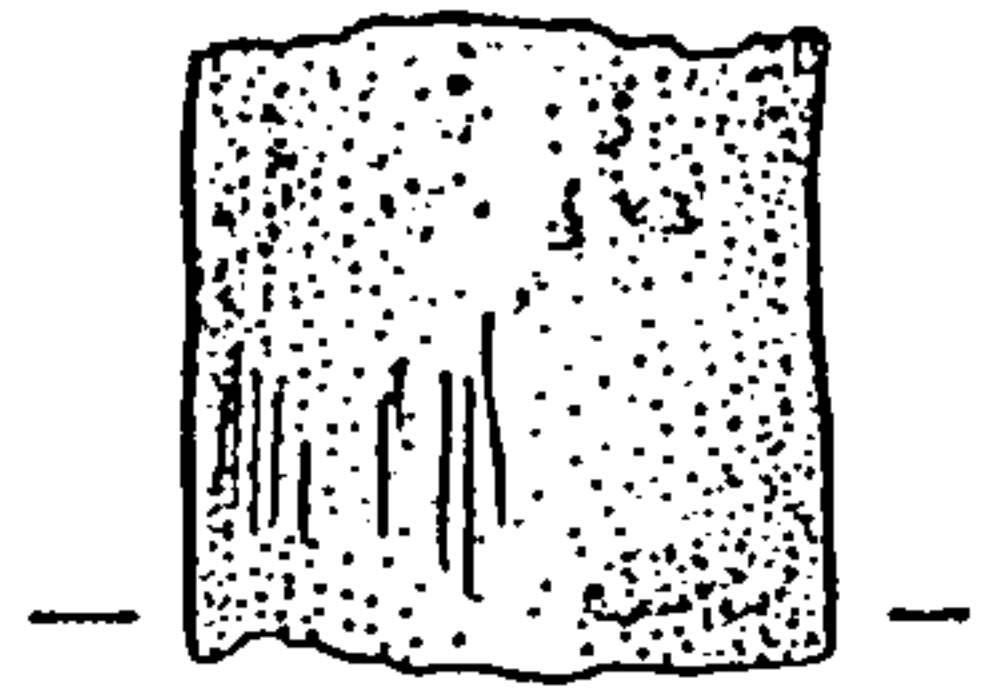
20/101



20/102



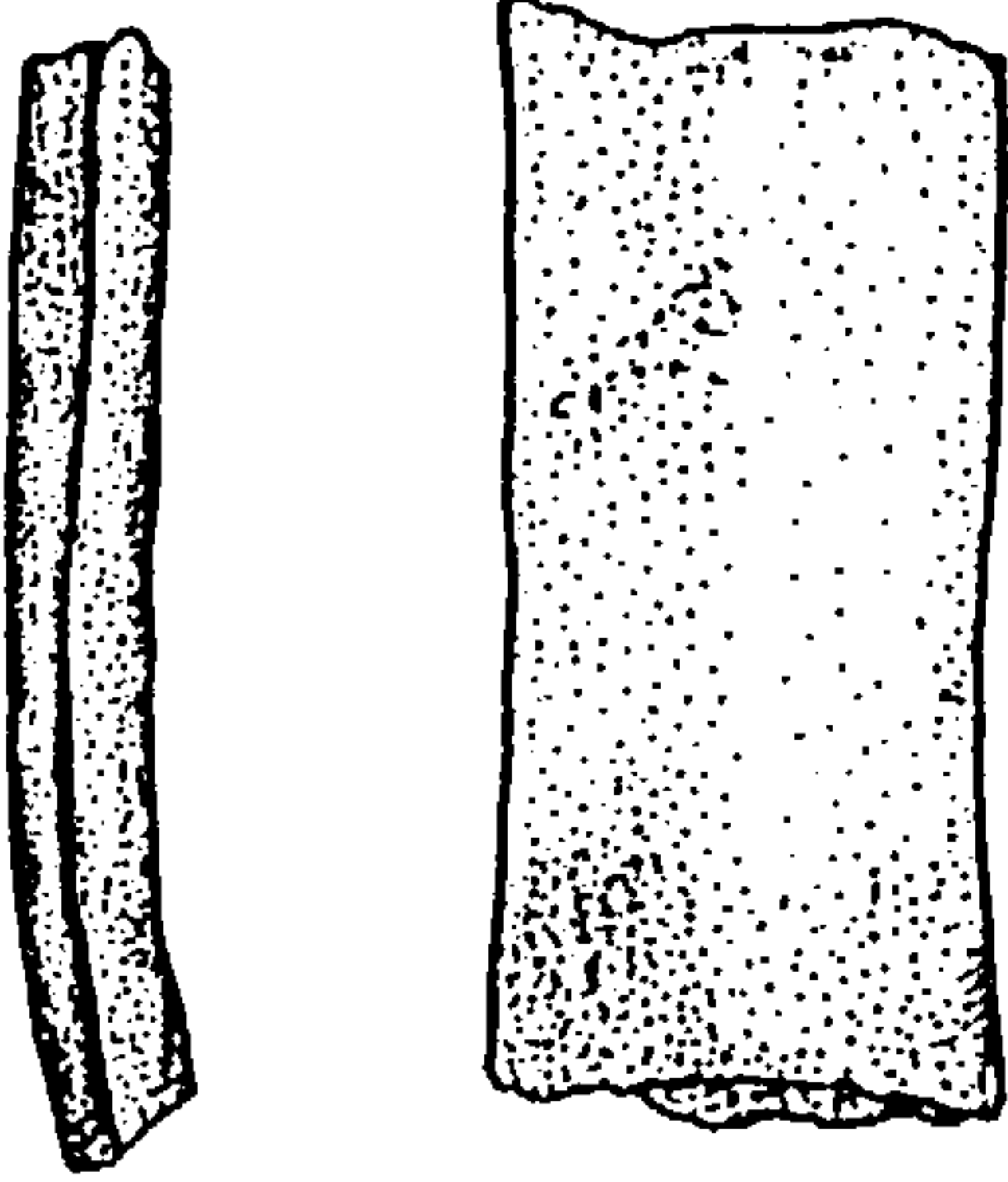
20/103



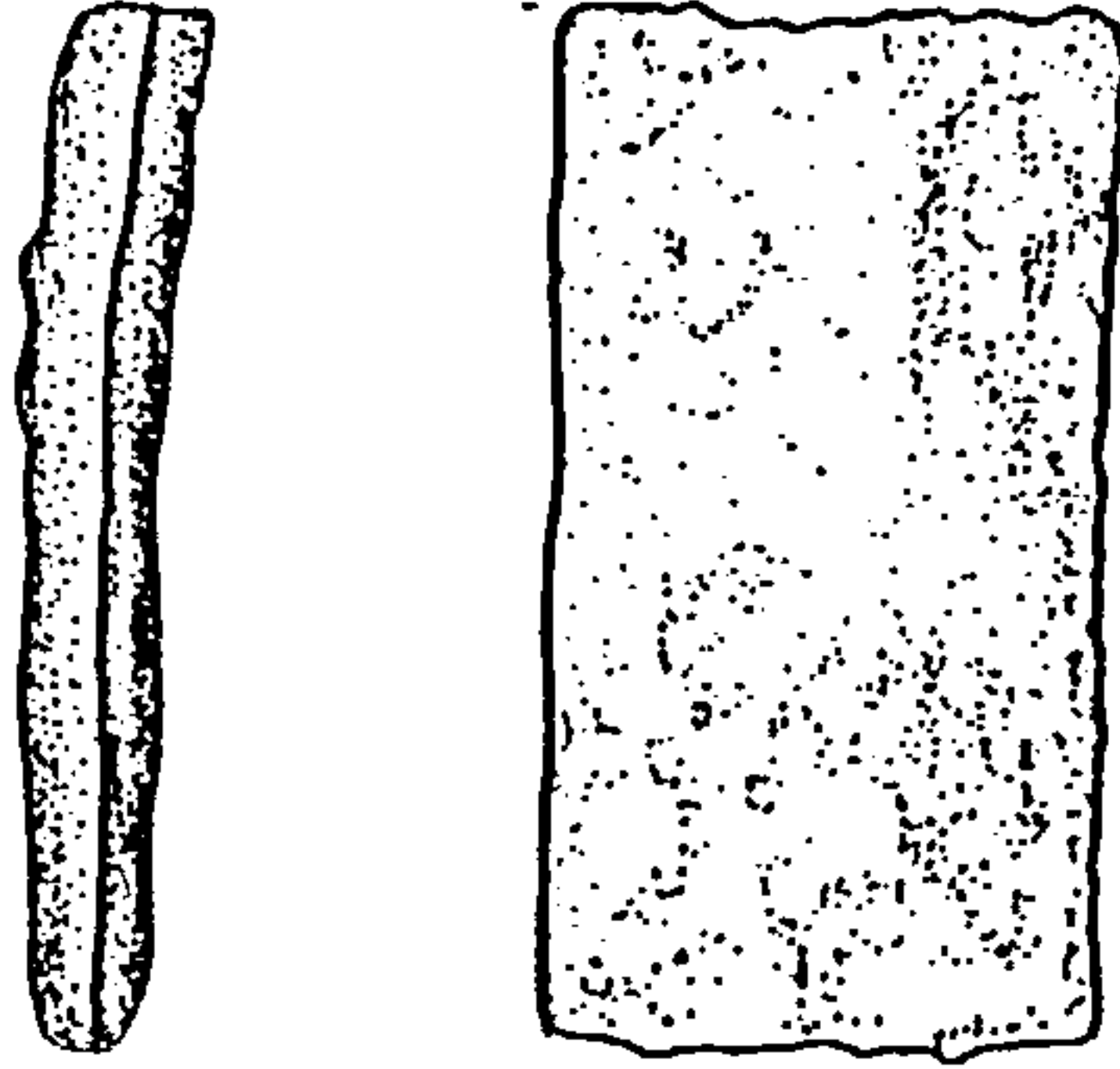
0 2cm



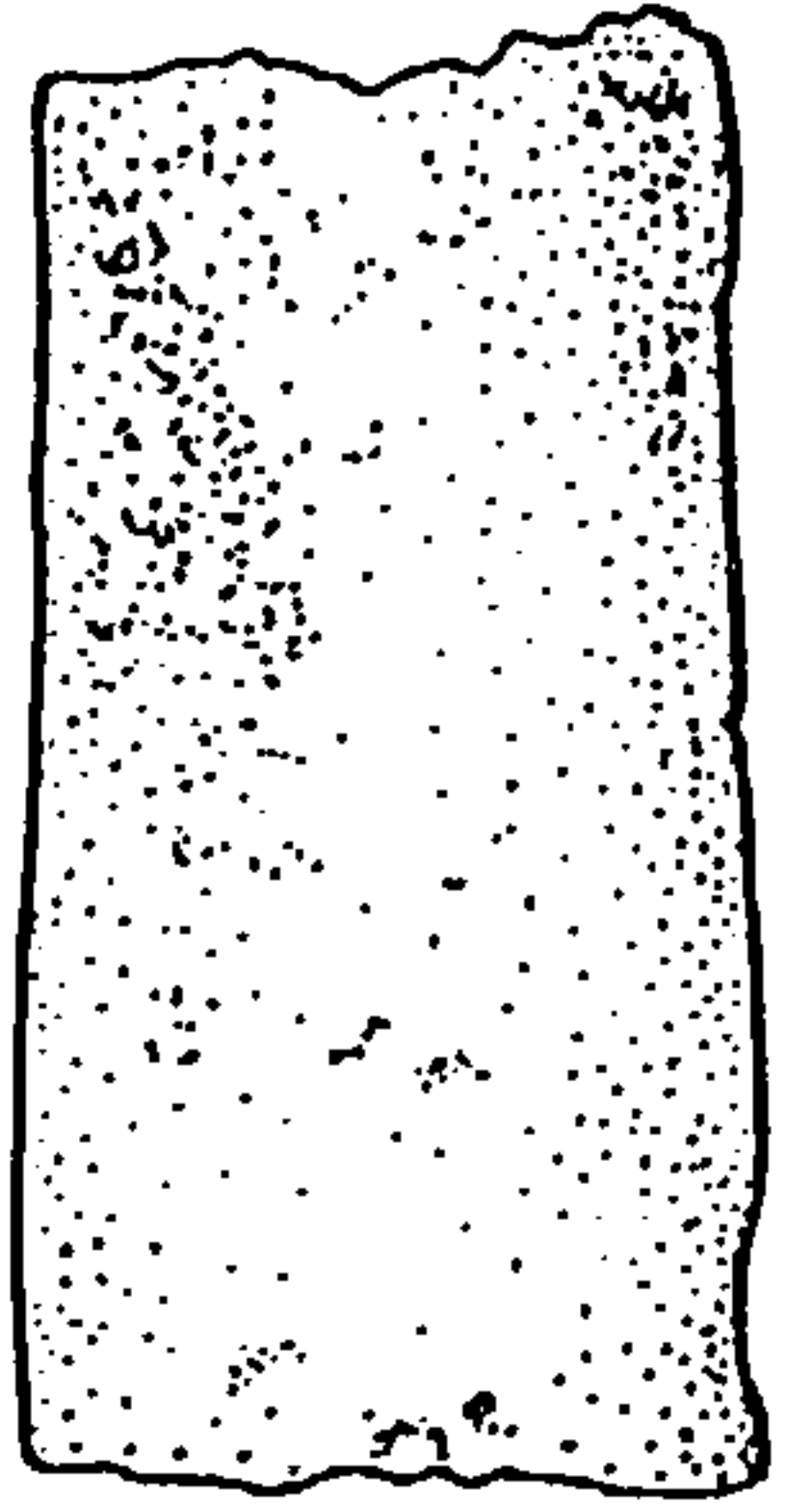
20/104



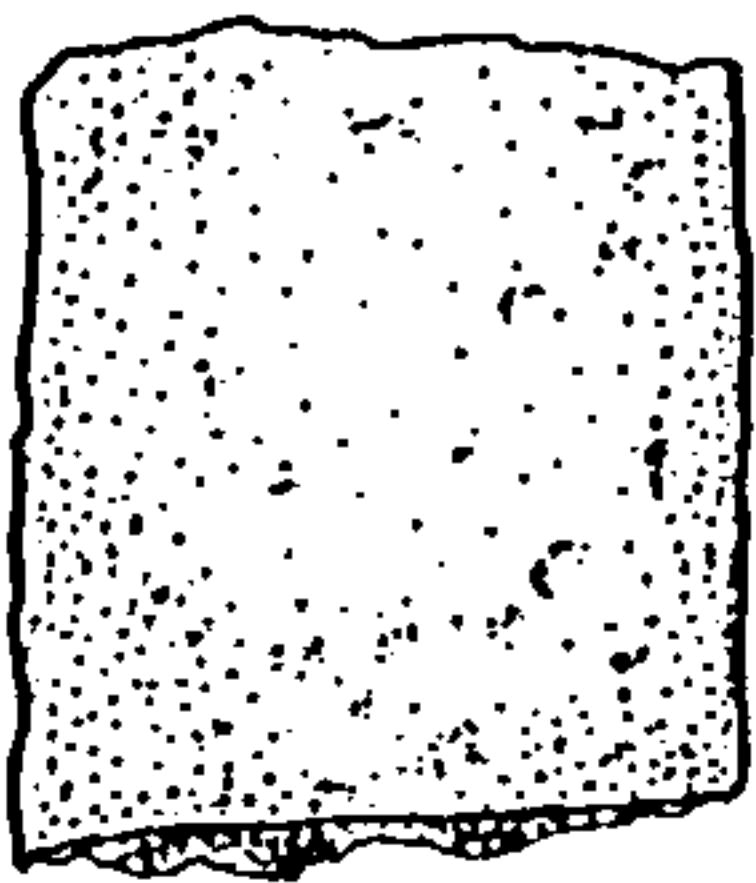
20/105



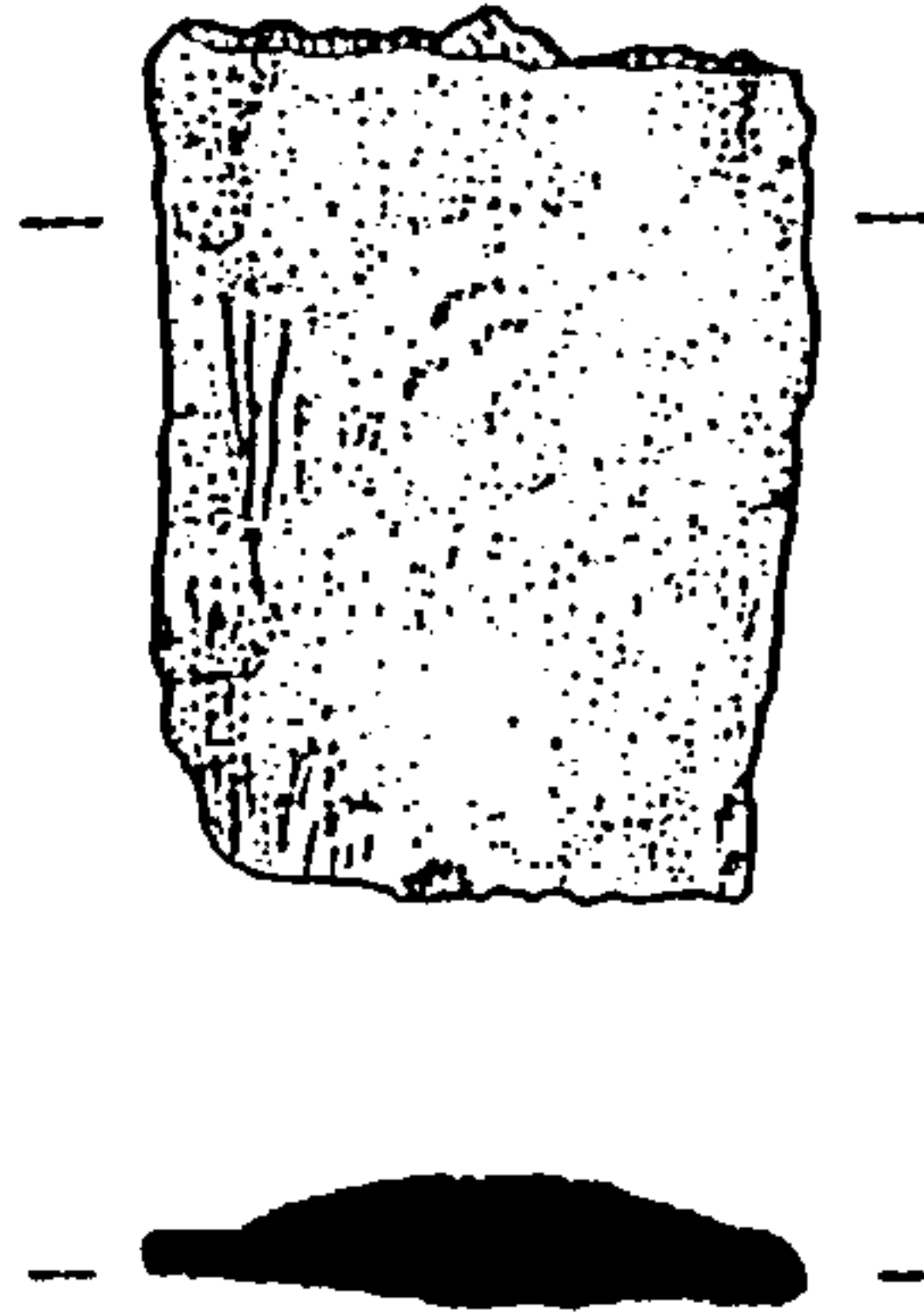
20/106



20/107



20/108



20/109

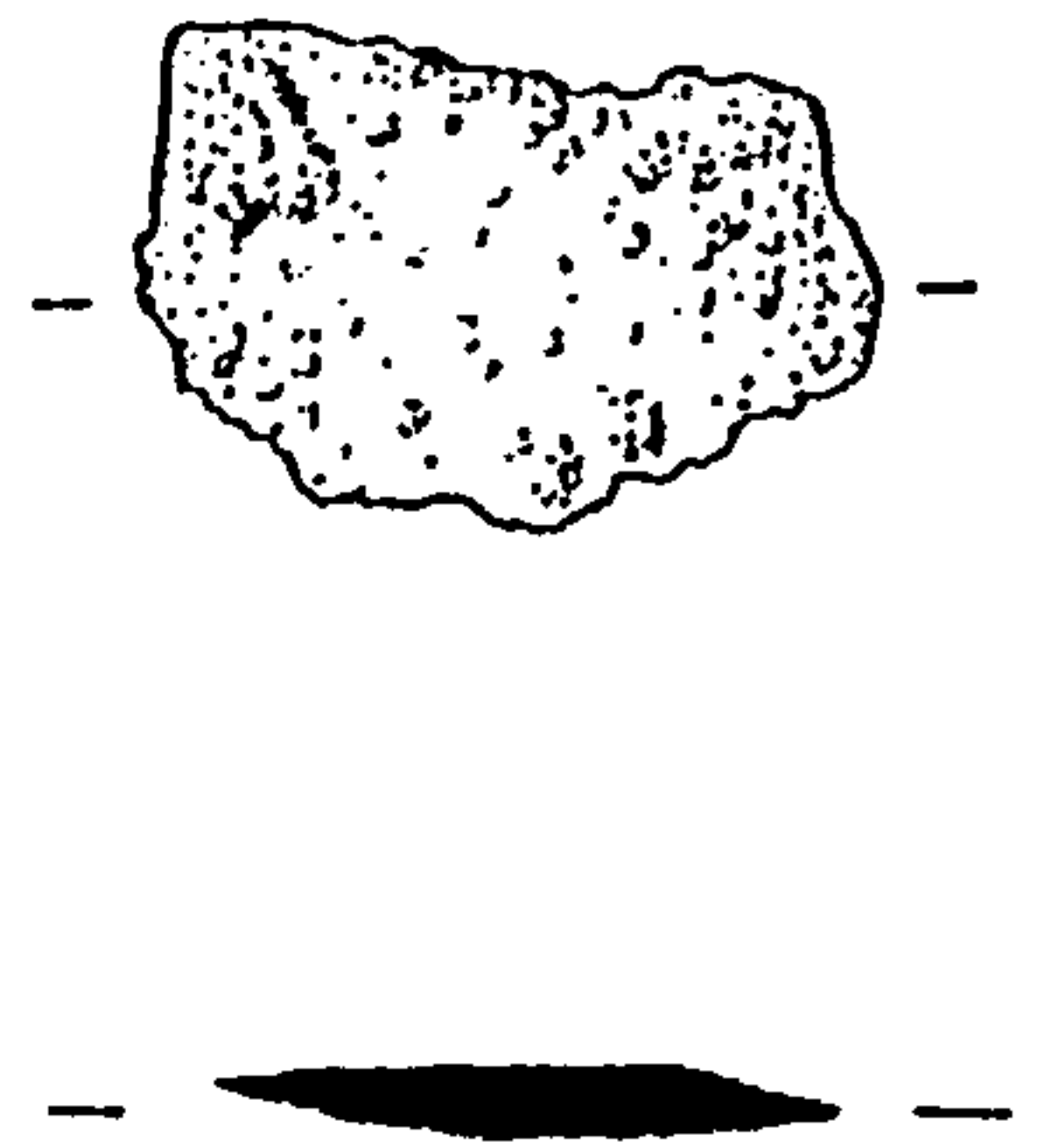
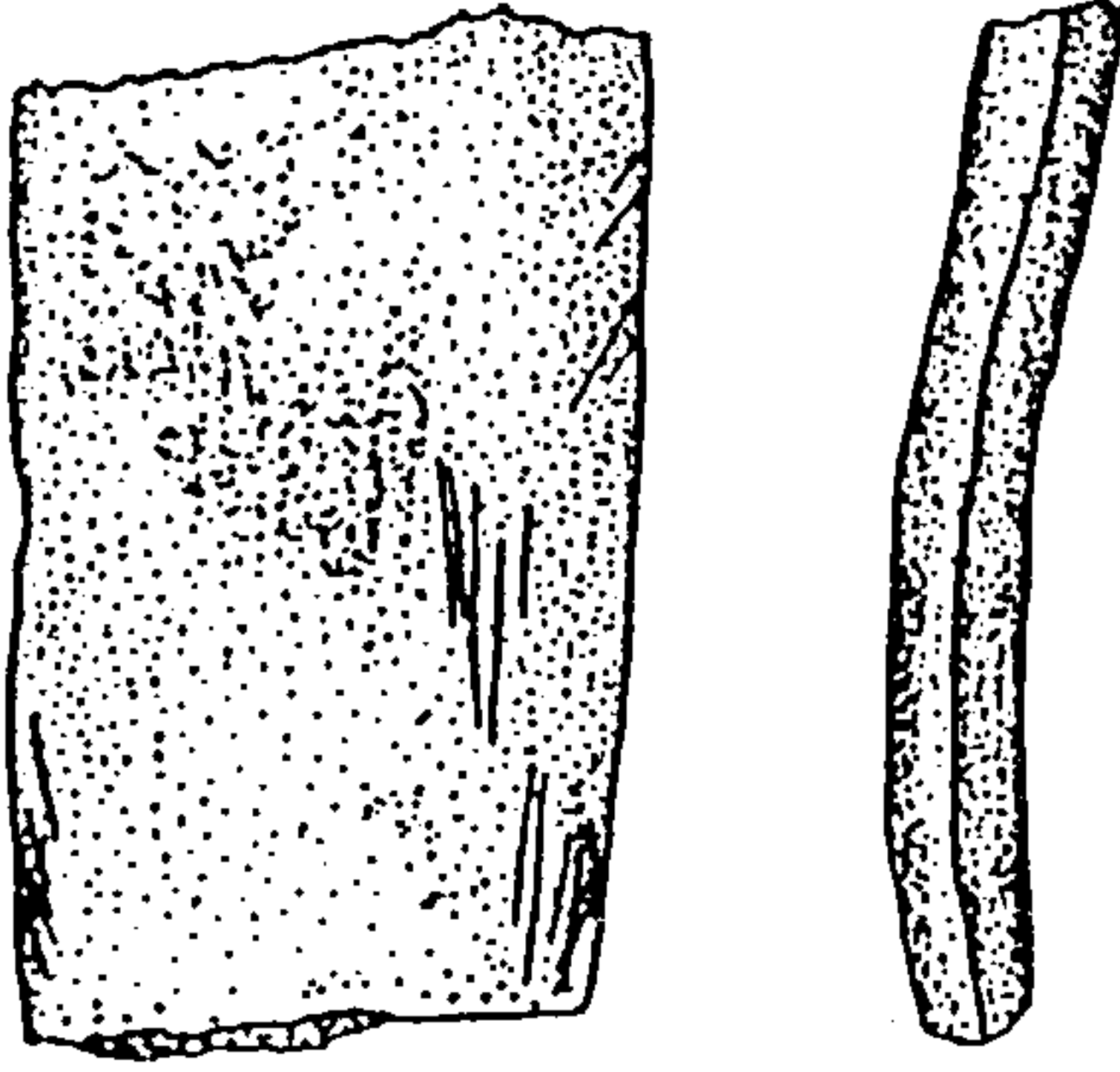
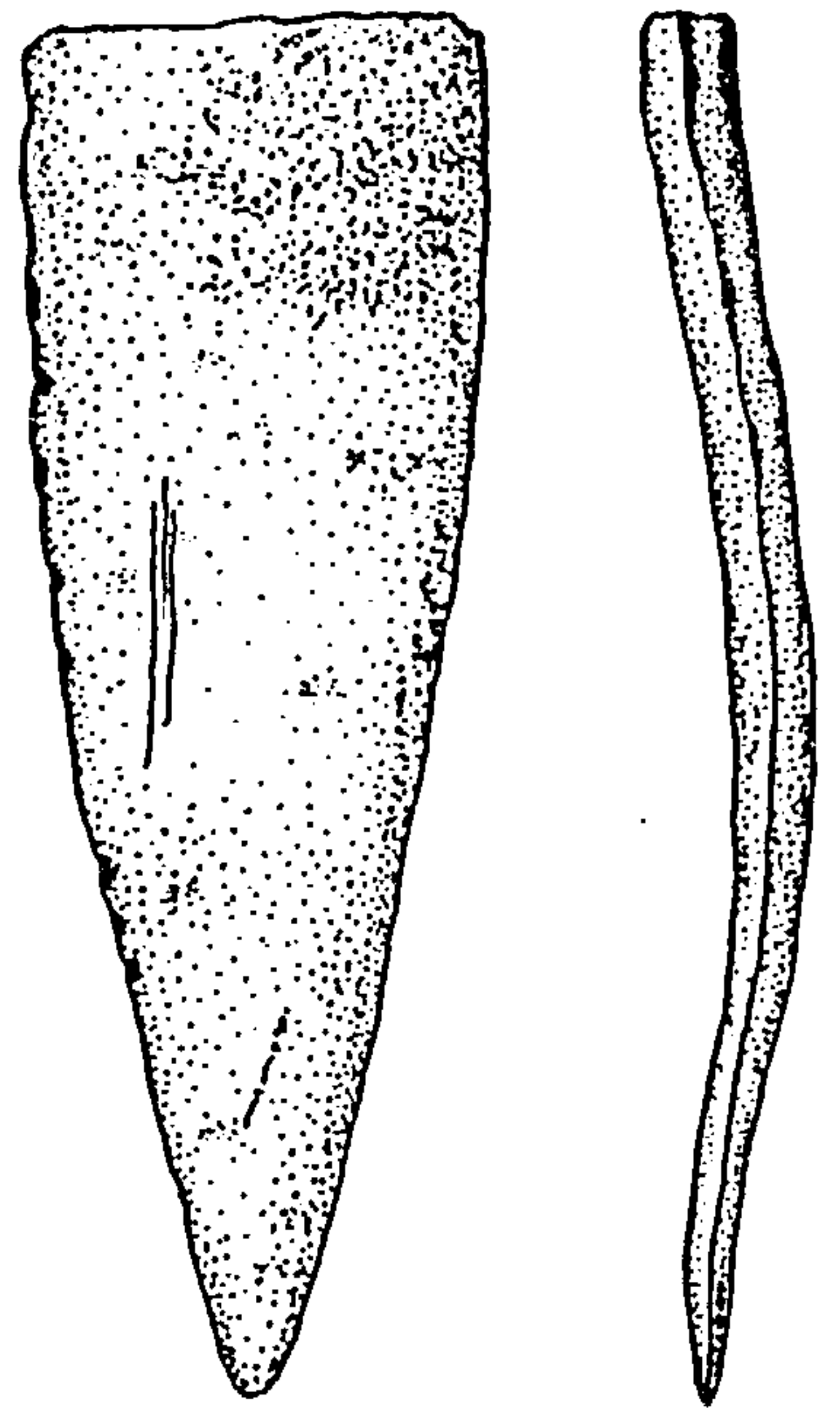


Fig. 68: The Minster Hoard (Ref. No. 20): Ewart Park Sword Blade Fragments (ii)

20/110

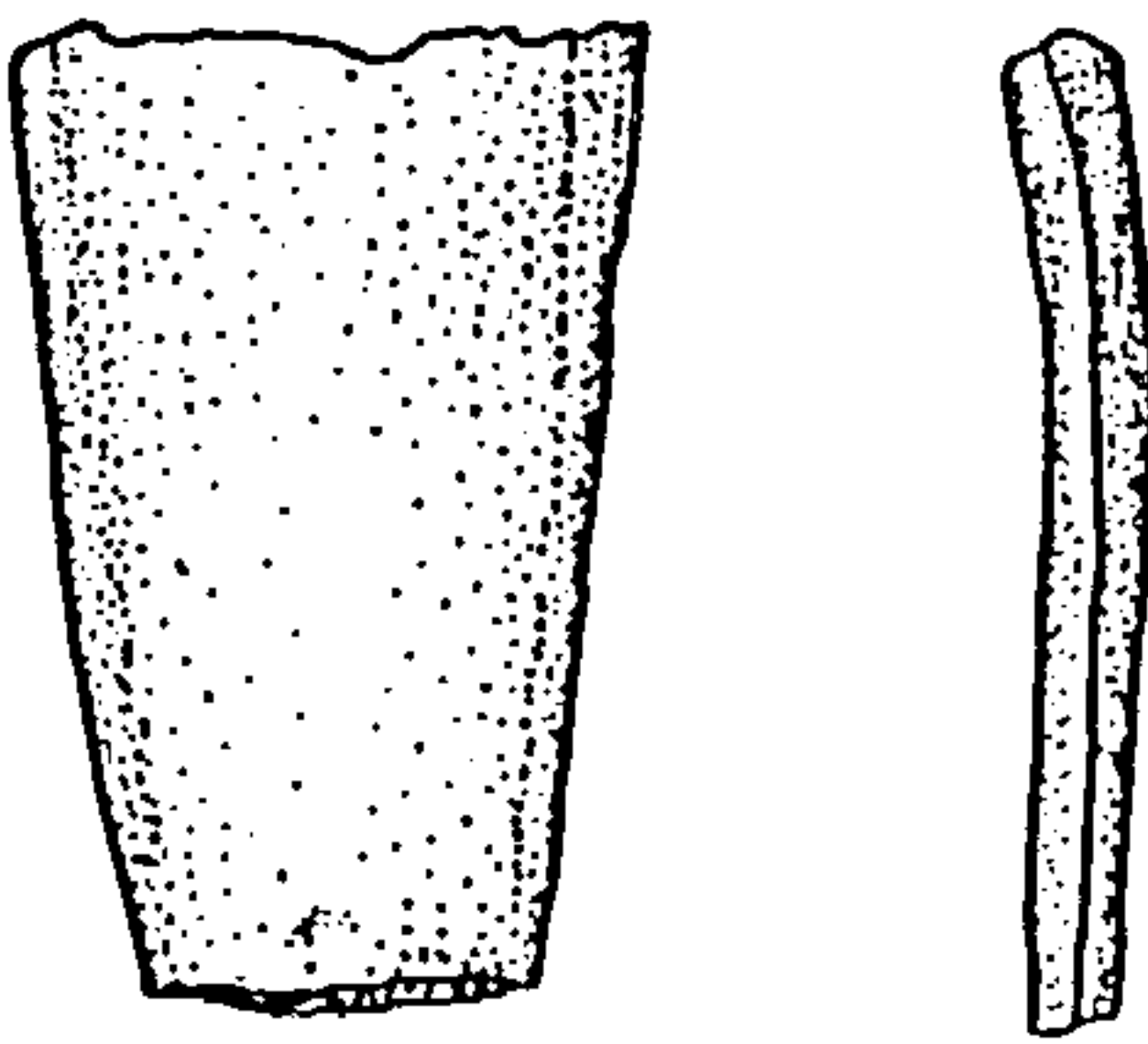


20/111

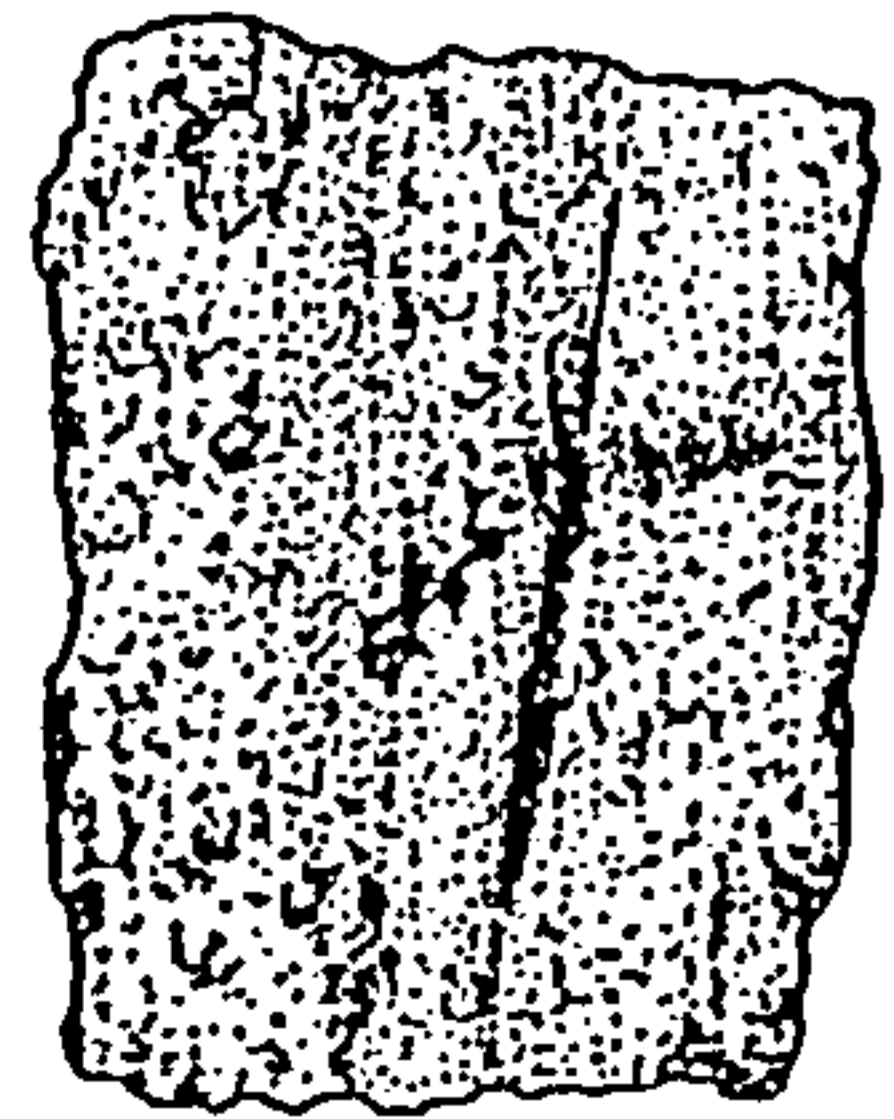


0 2cm

20/112



20/113



20/114

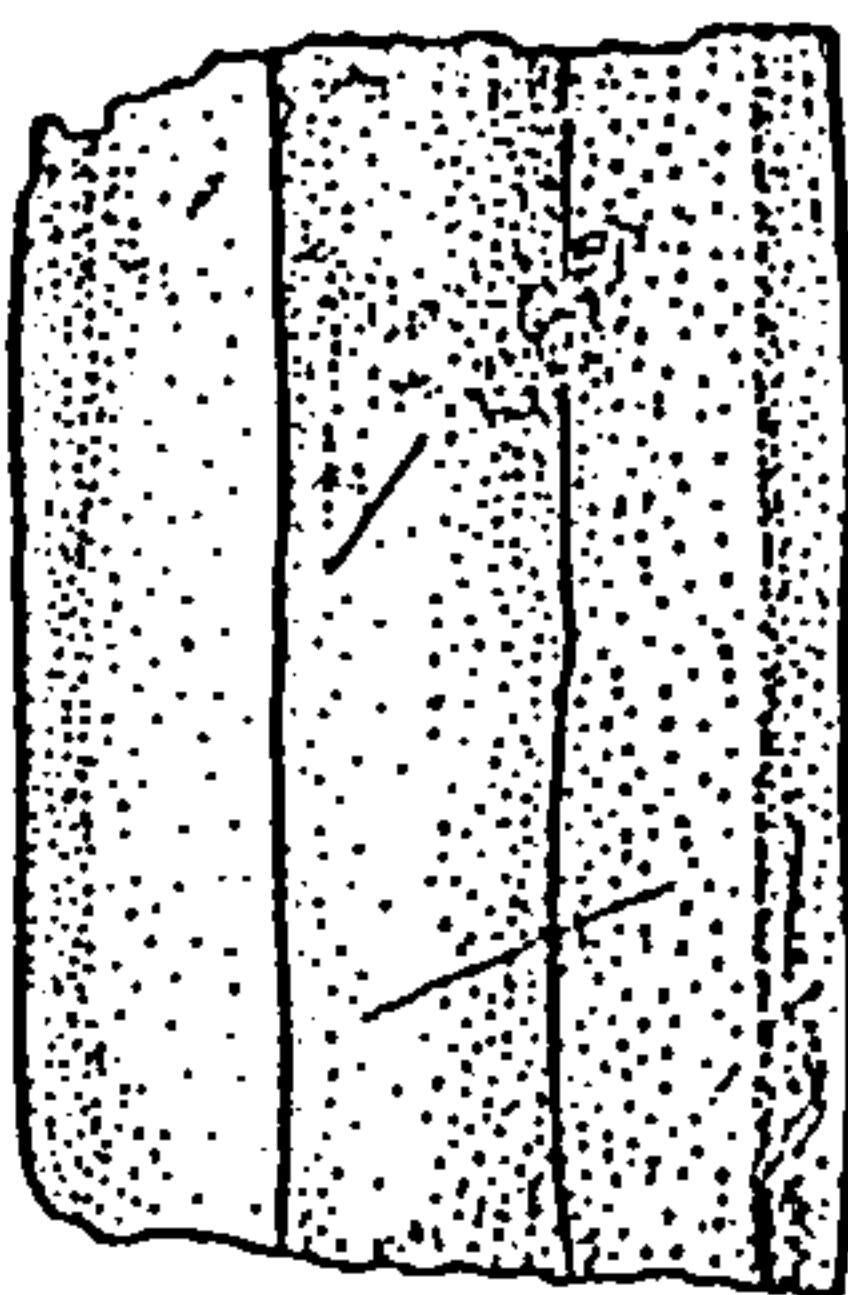
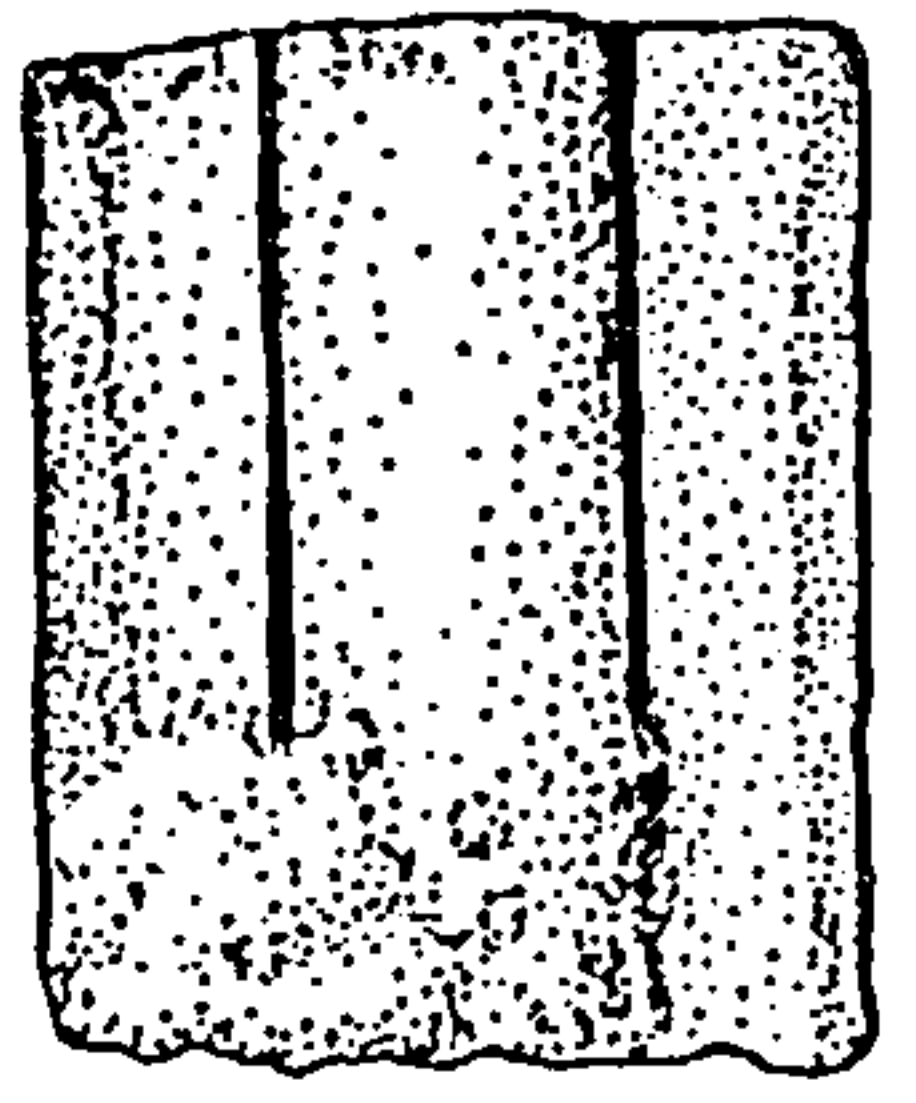
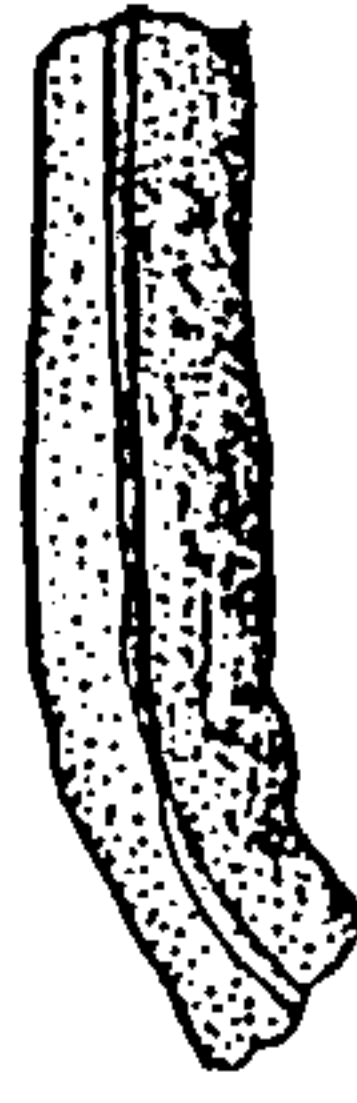


Fig. 69: The Minster Hoard (Ref. No. 20): Sword Blade Fragments

20/115



20/116

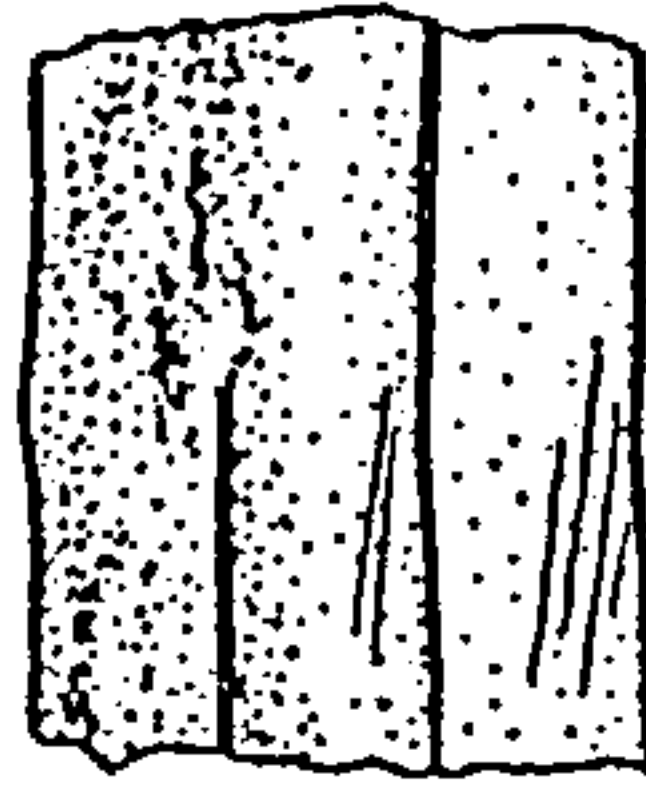


0 2cm

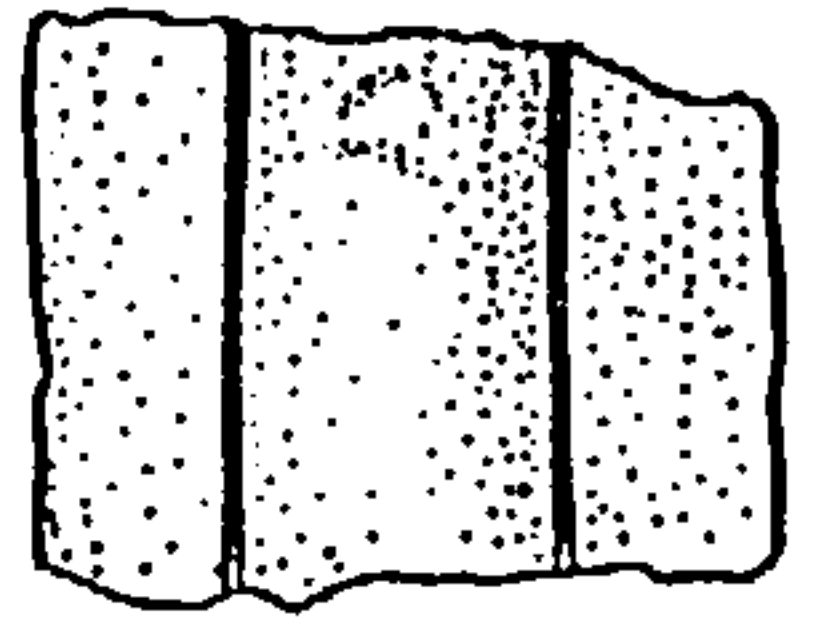
20/117



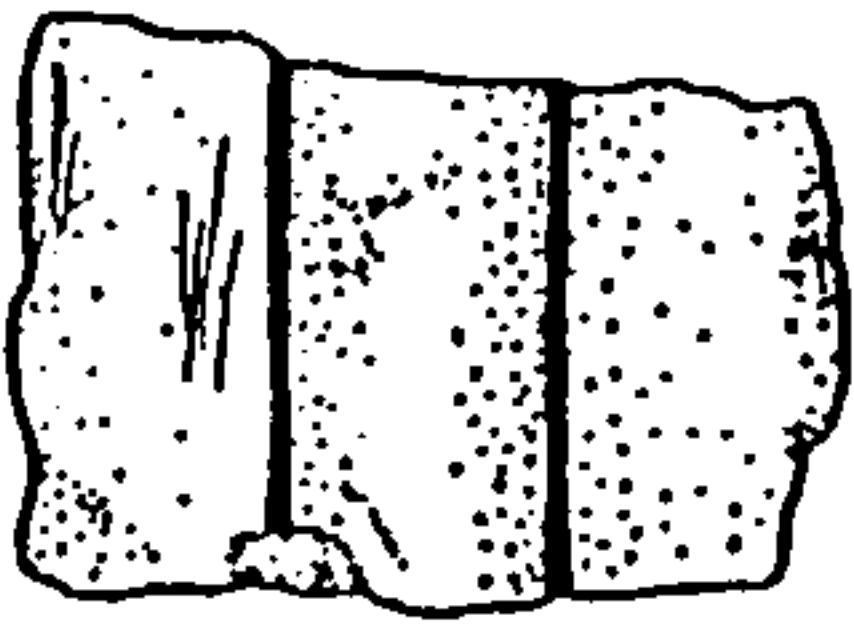
20/118



20/119



20/120



20/121

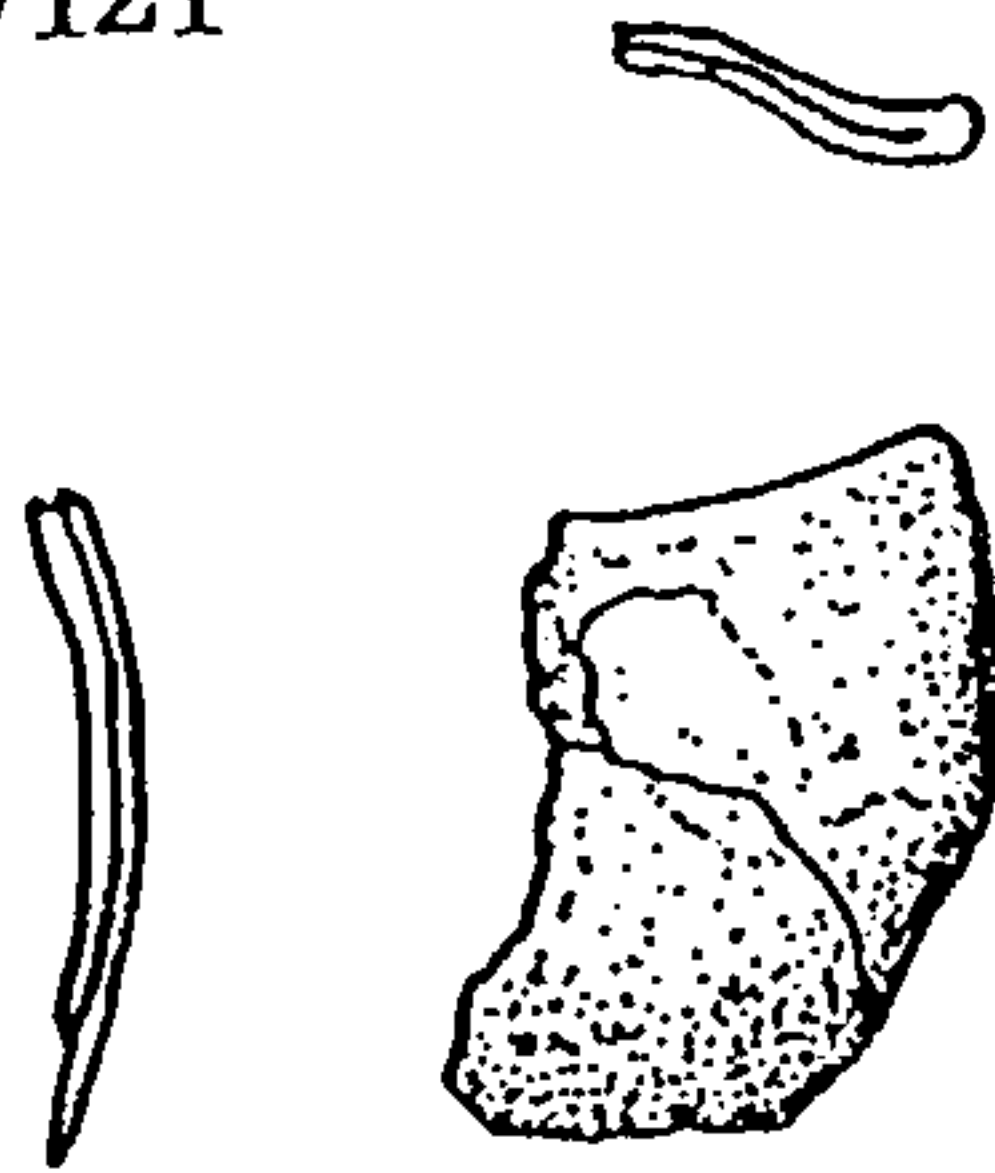
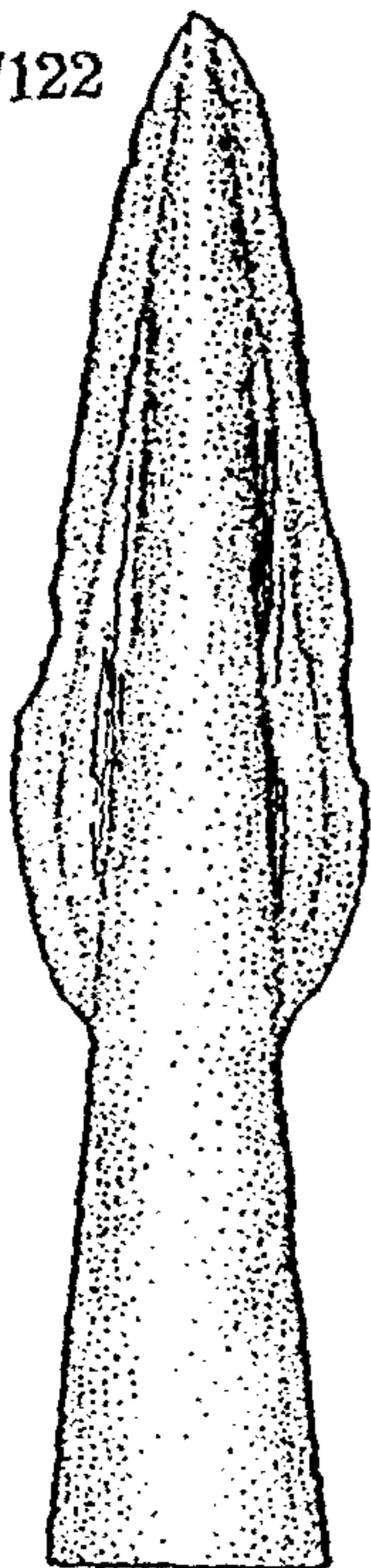
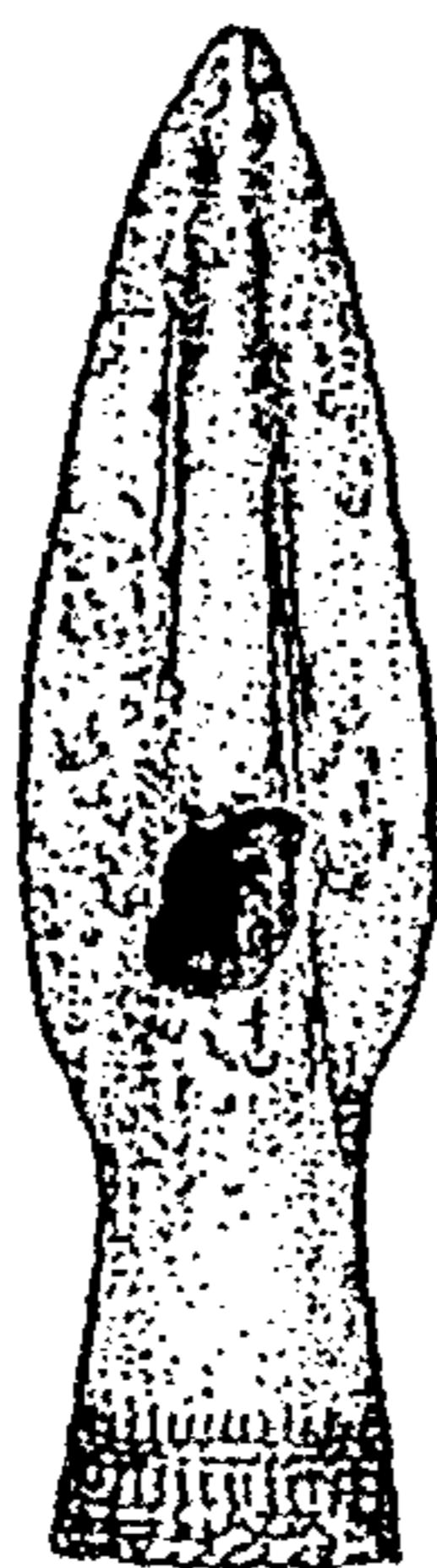


Fig. 70: The Minster Hoard (Ref. No. 20): 'Carp's Tongue' Sword Blade Fragments and Scabbard Chape

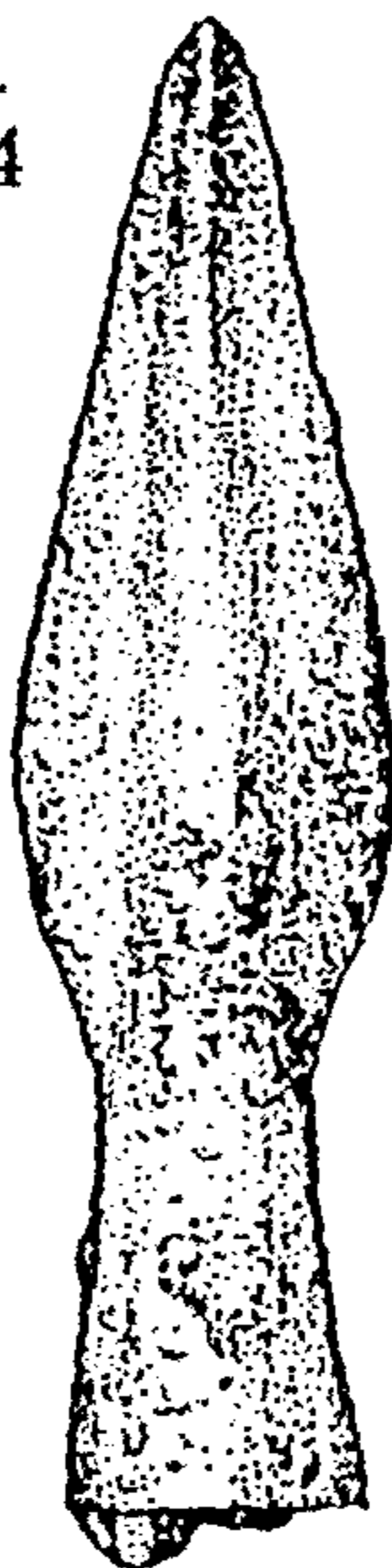
20/122



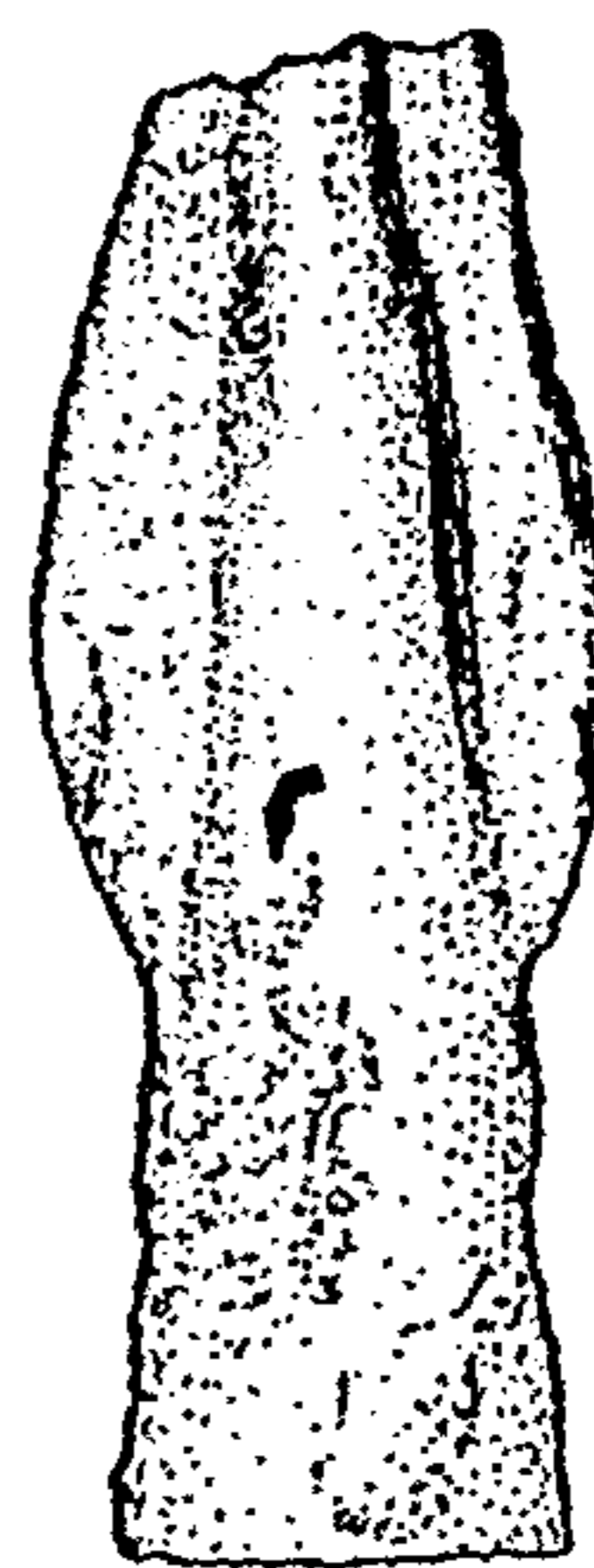
20/123



20/124



20/125

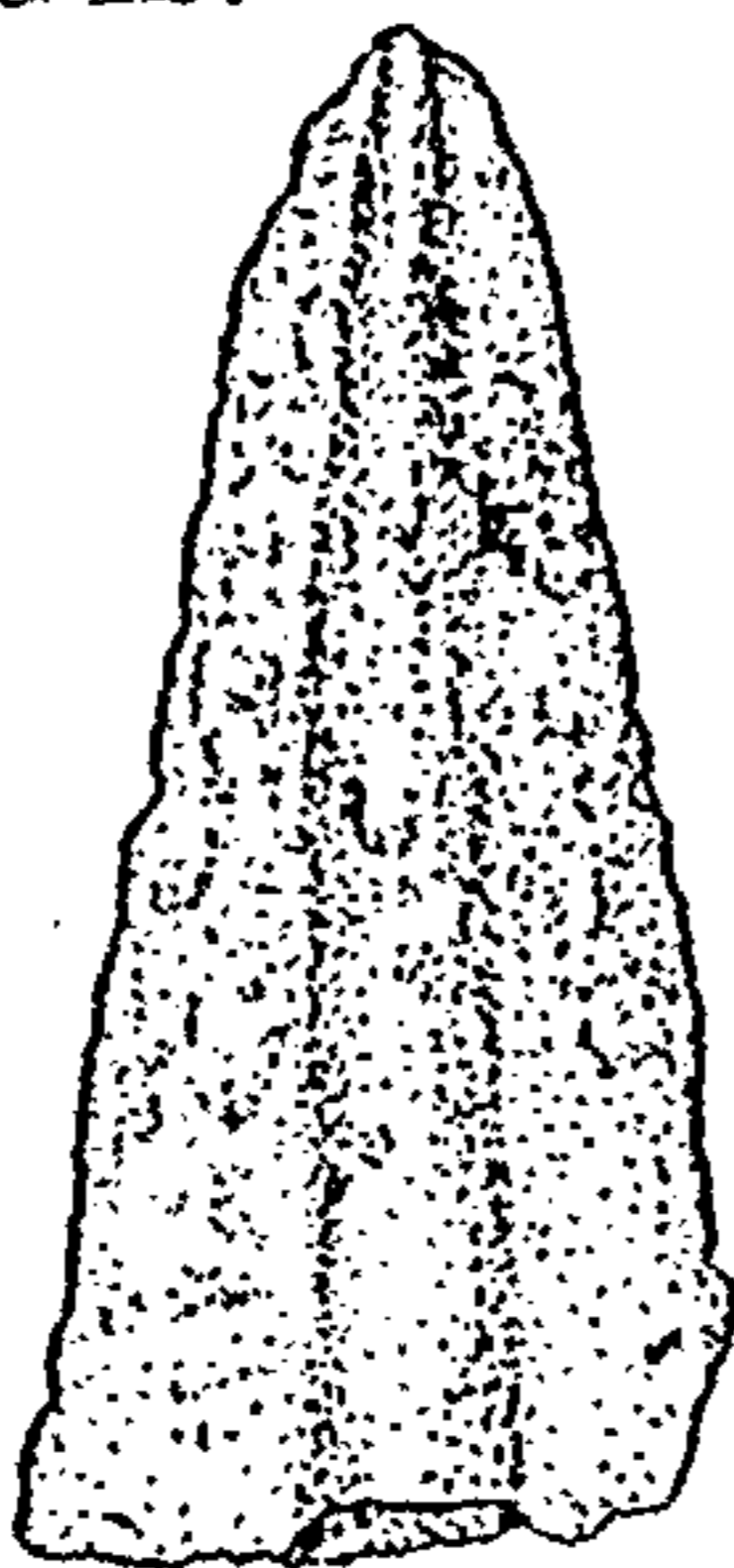


0 2cm

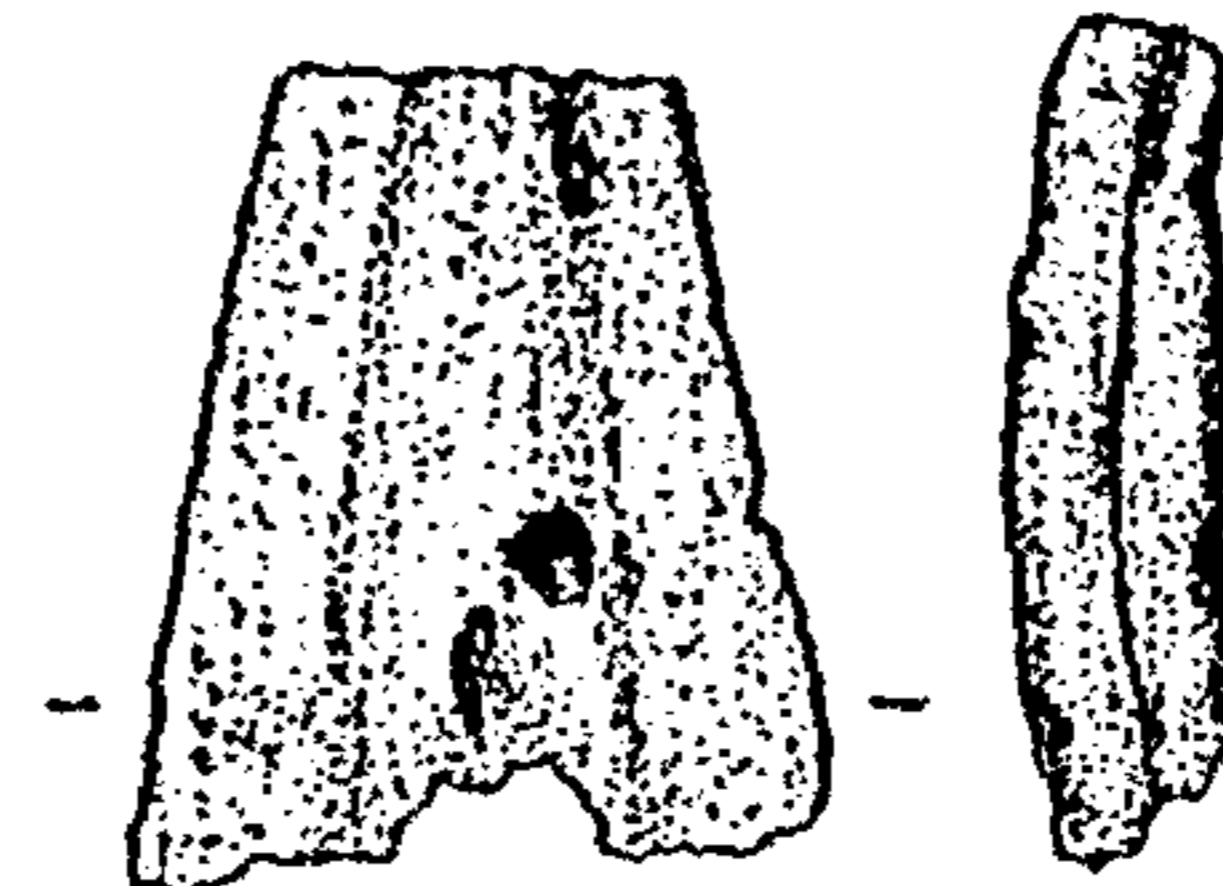
20/126



20/127



20/128



20/129



Fig. 71: The Minster Hoard (Ref. No. 20): Spearheads

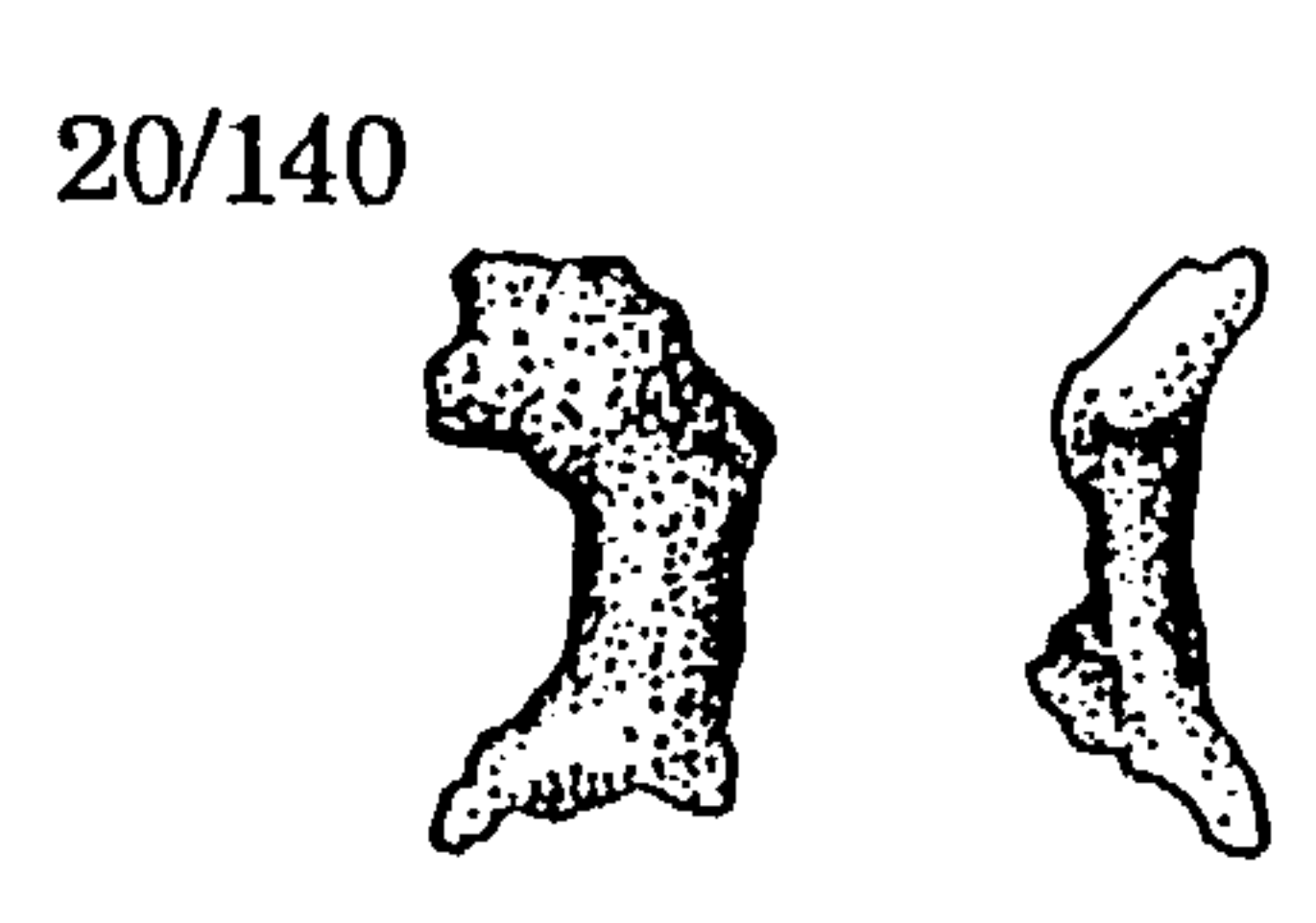
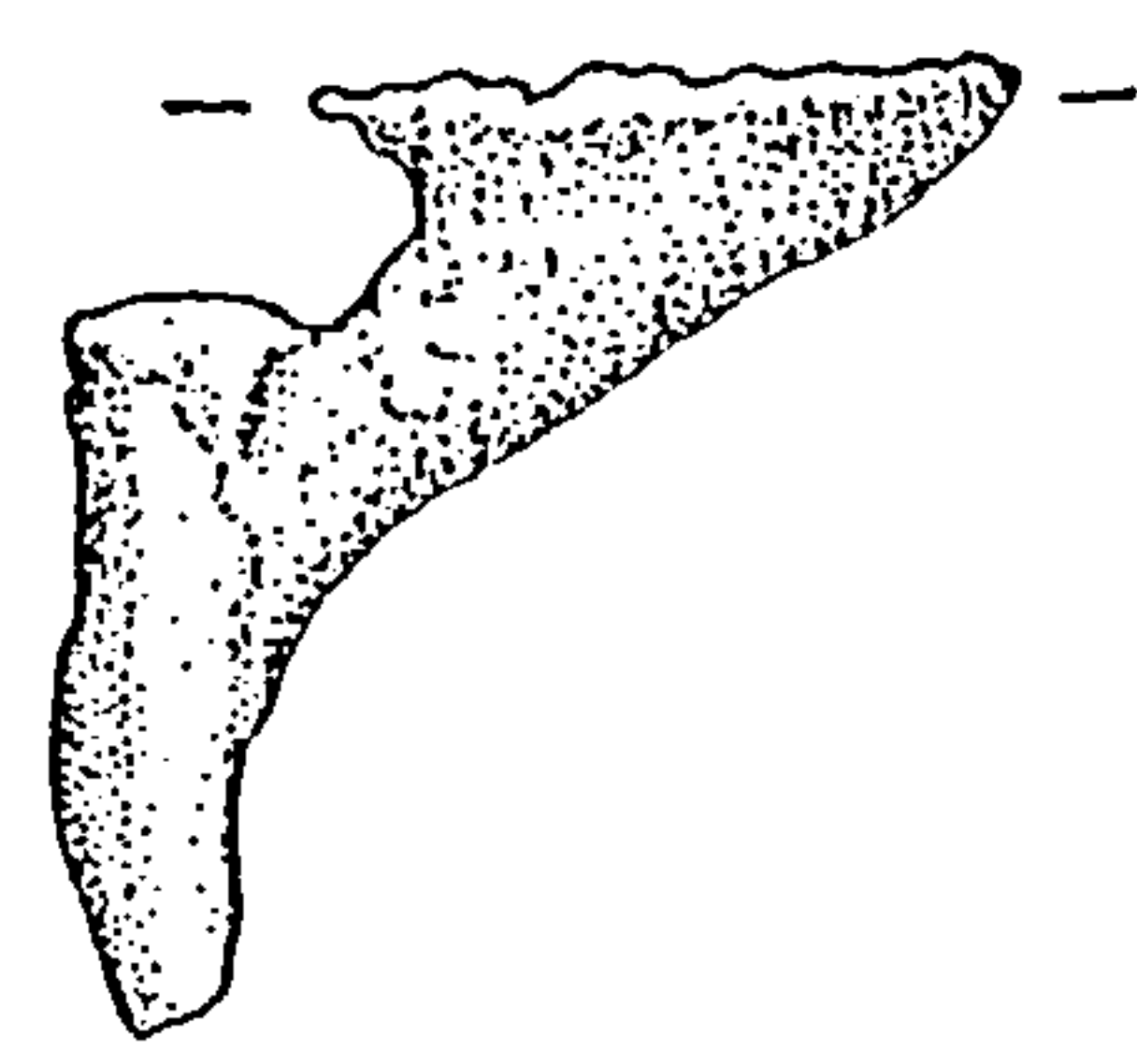
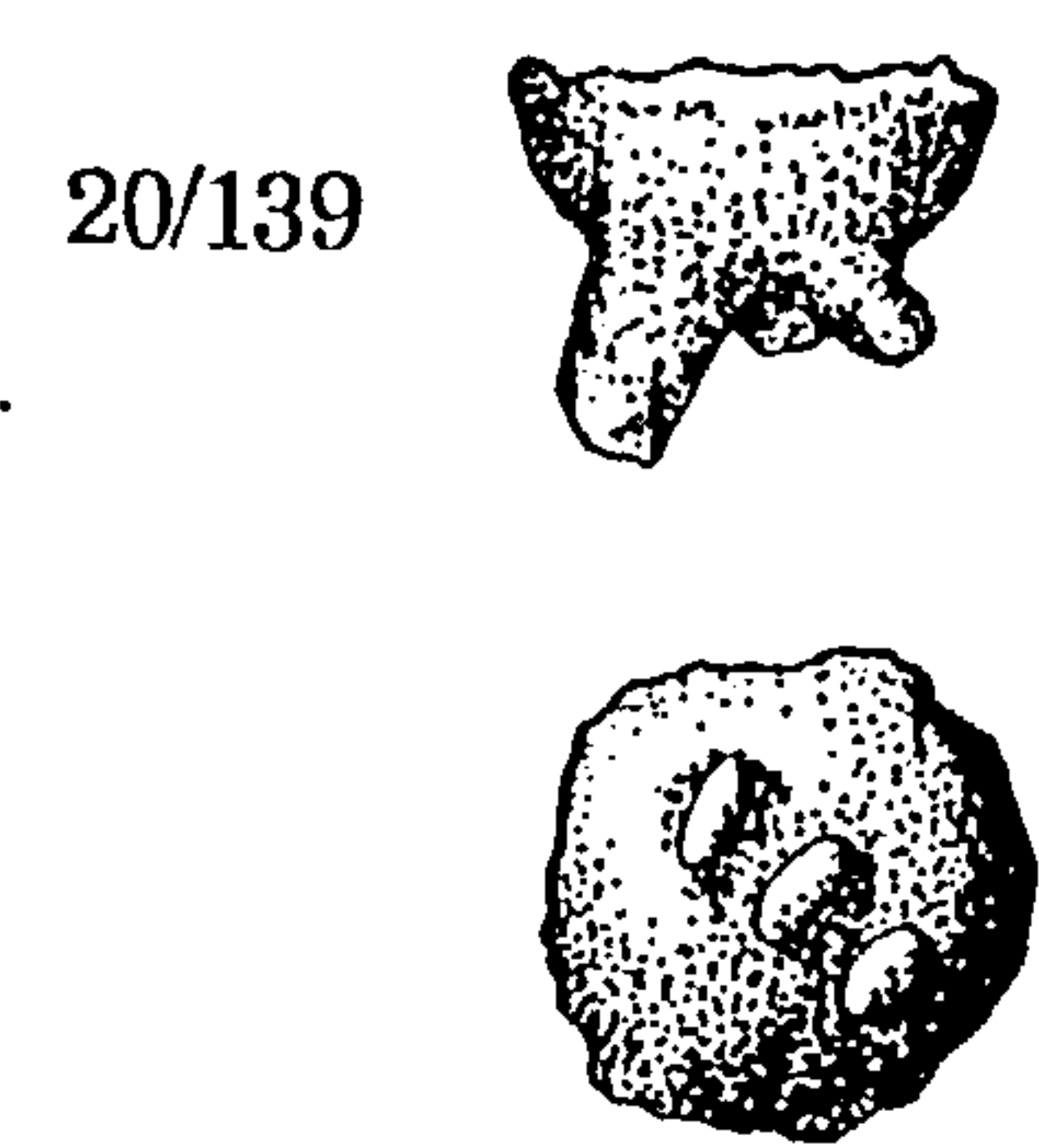
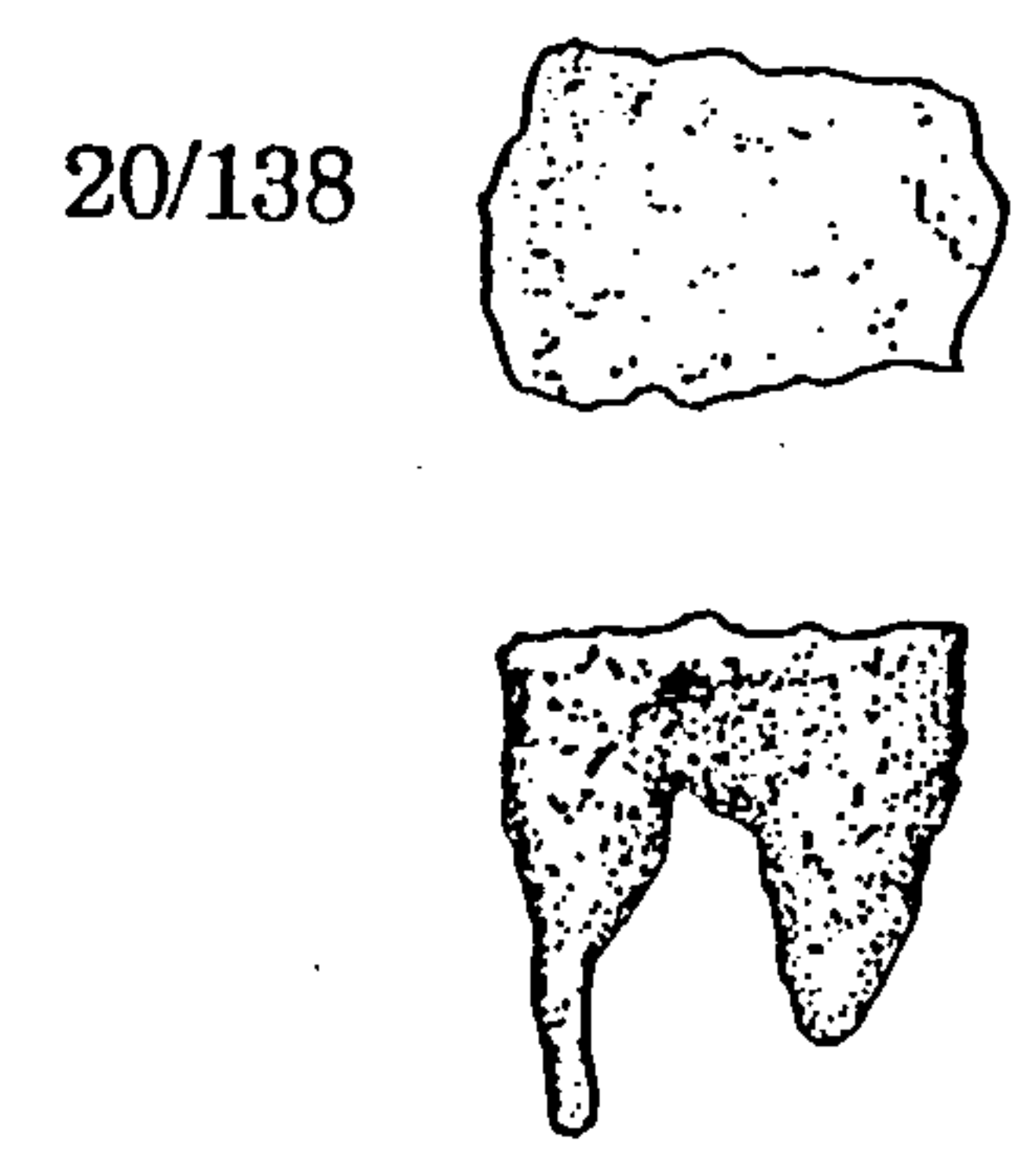
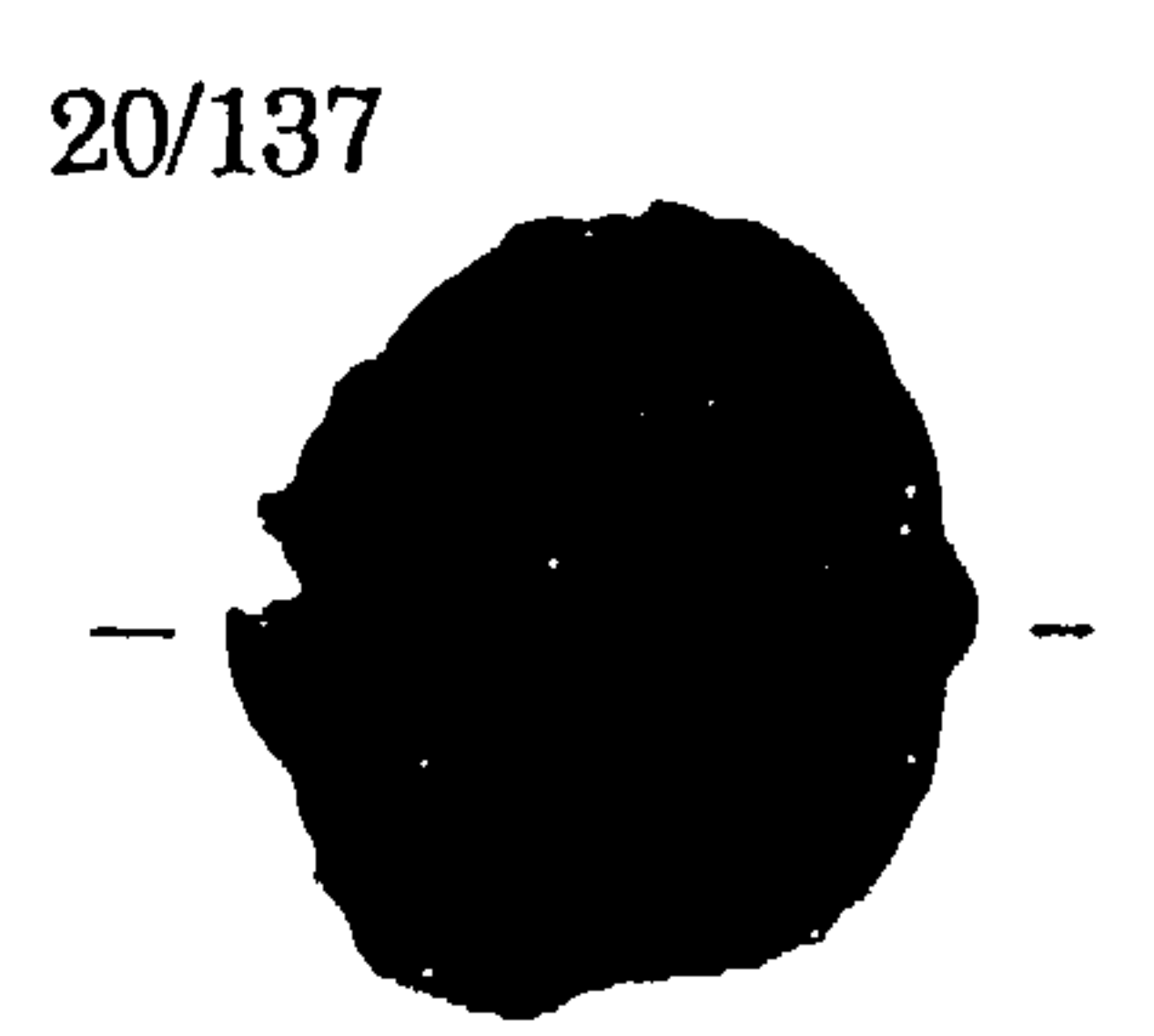
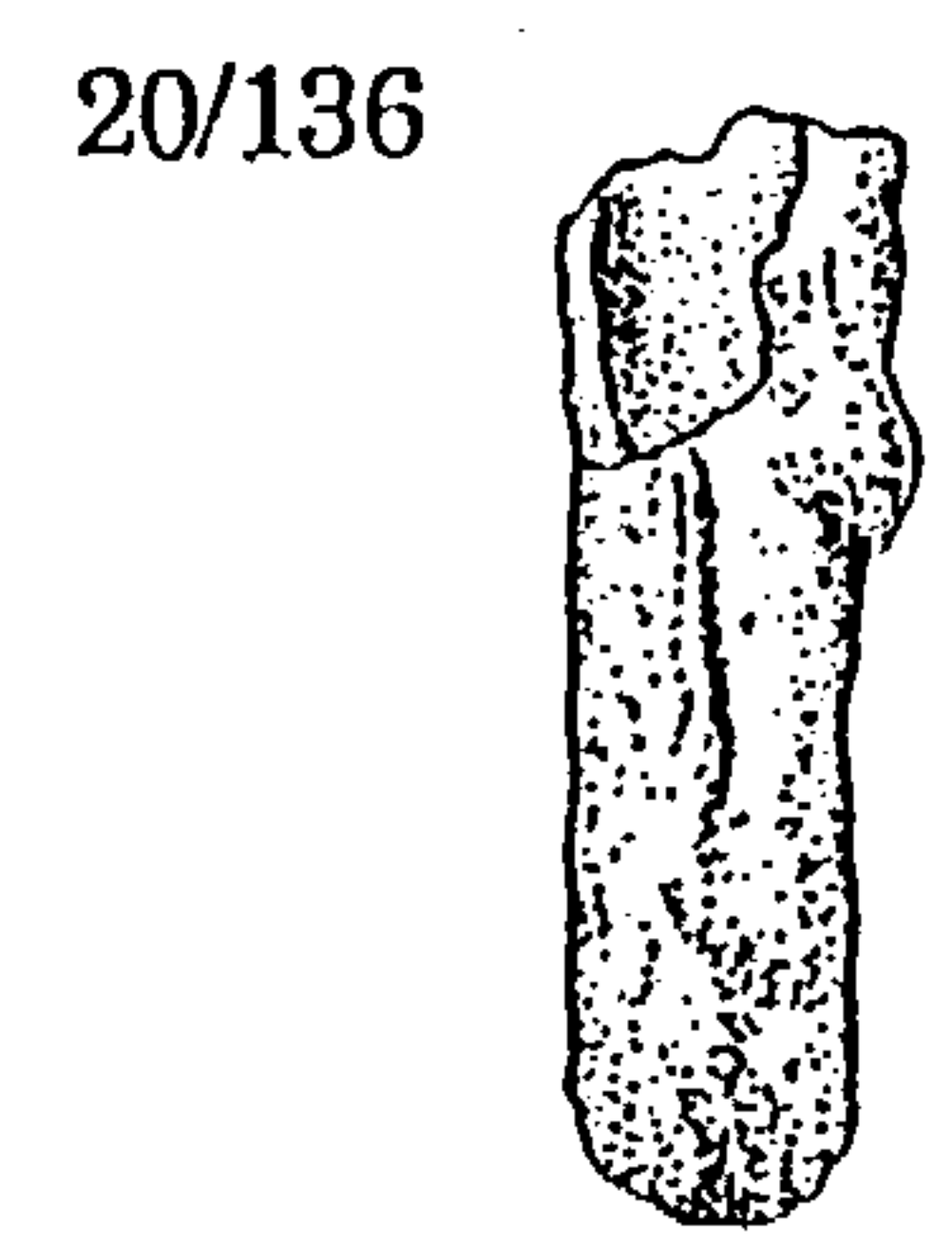
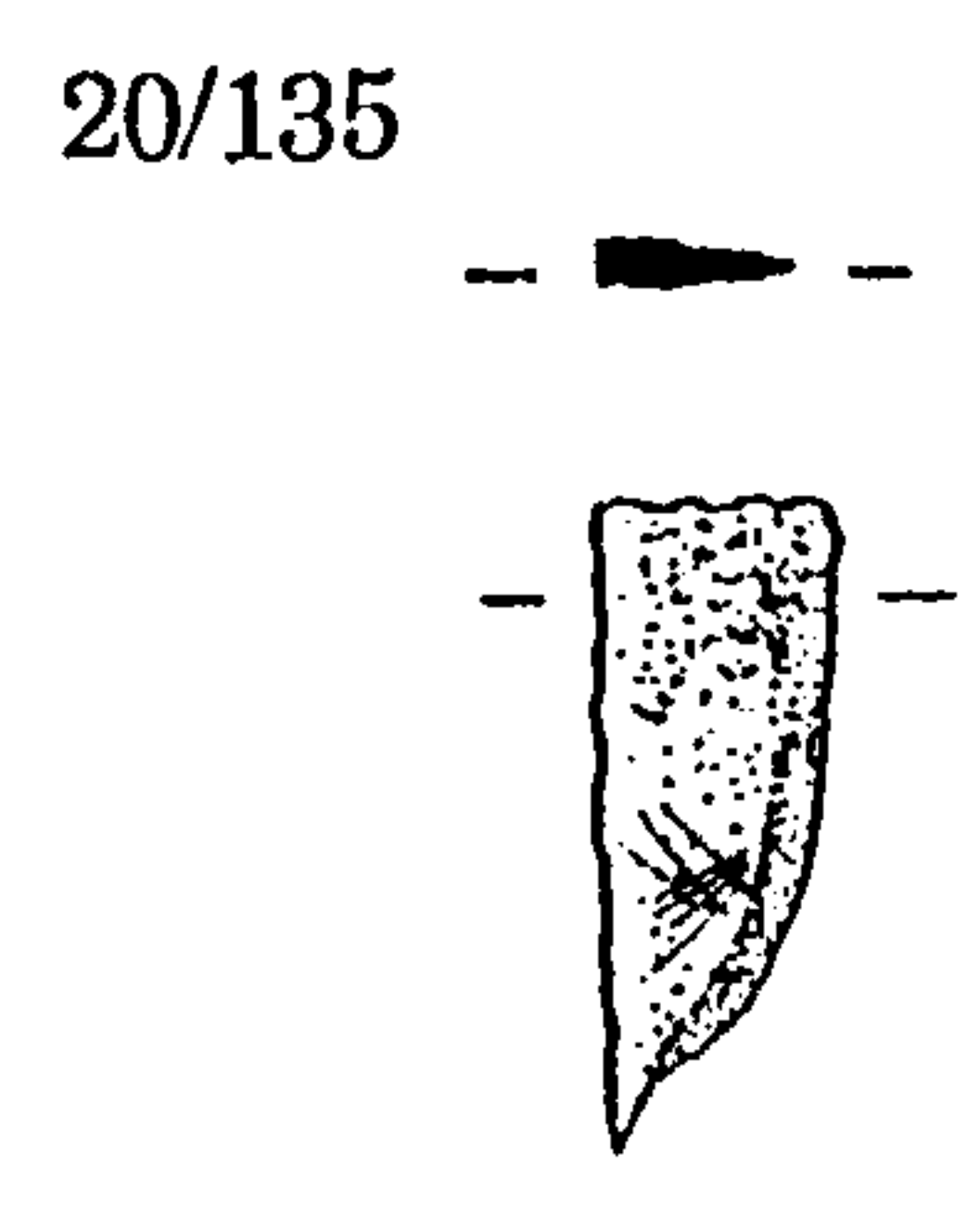
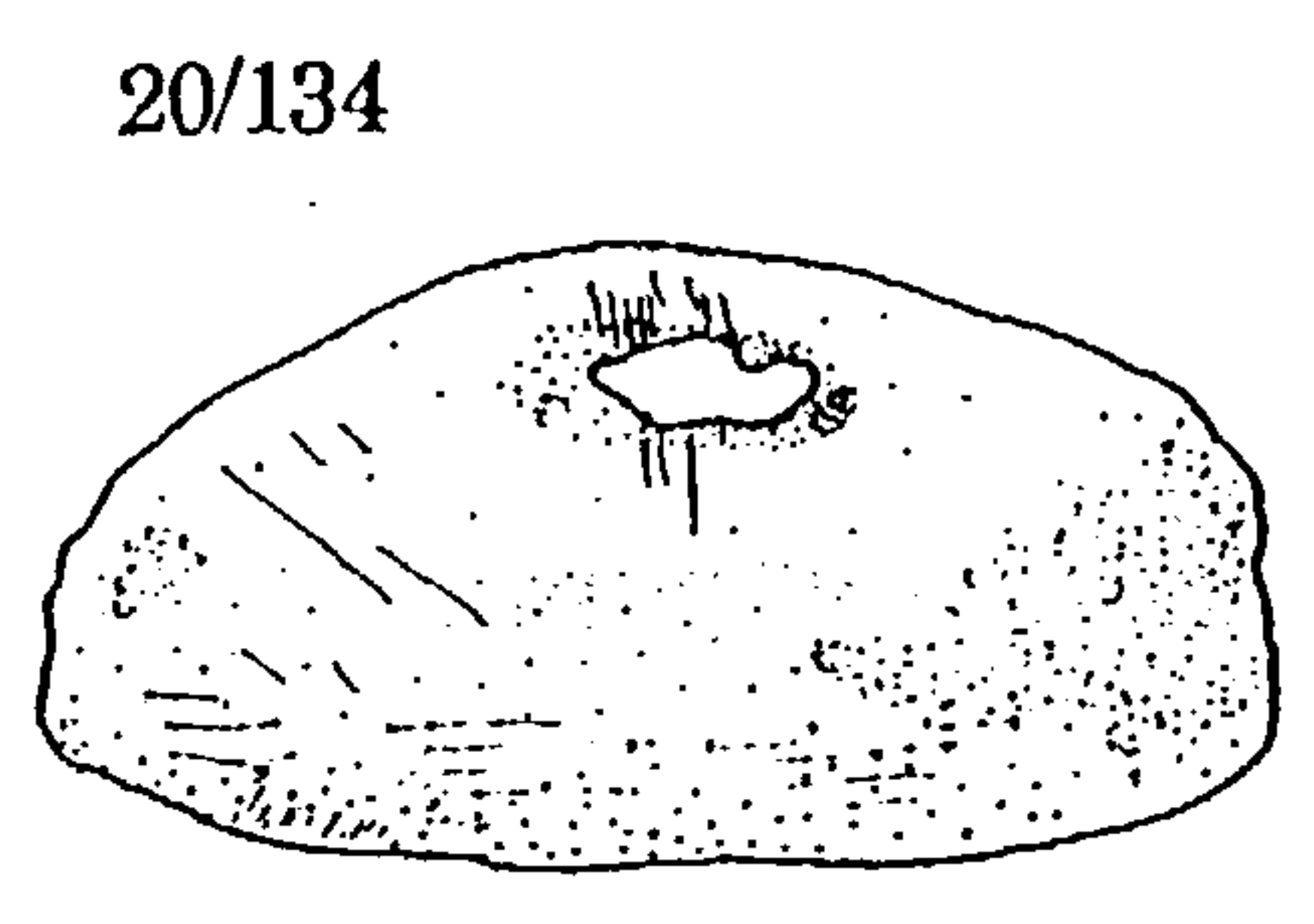
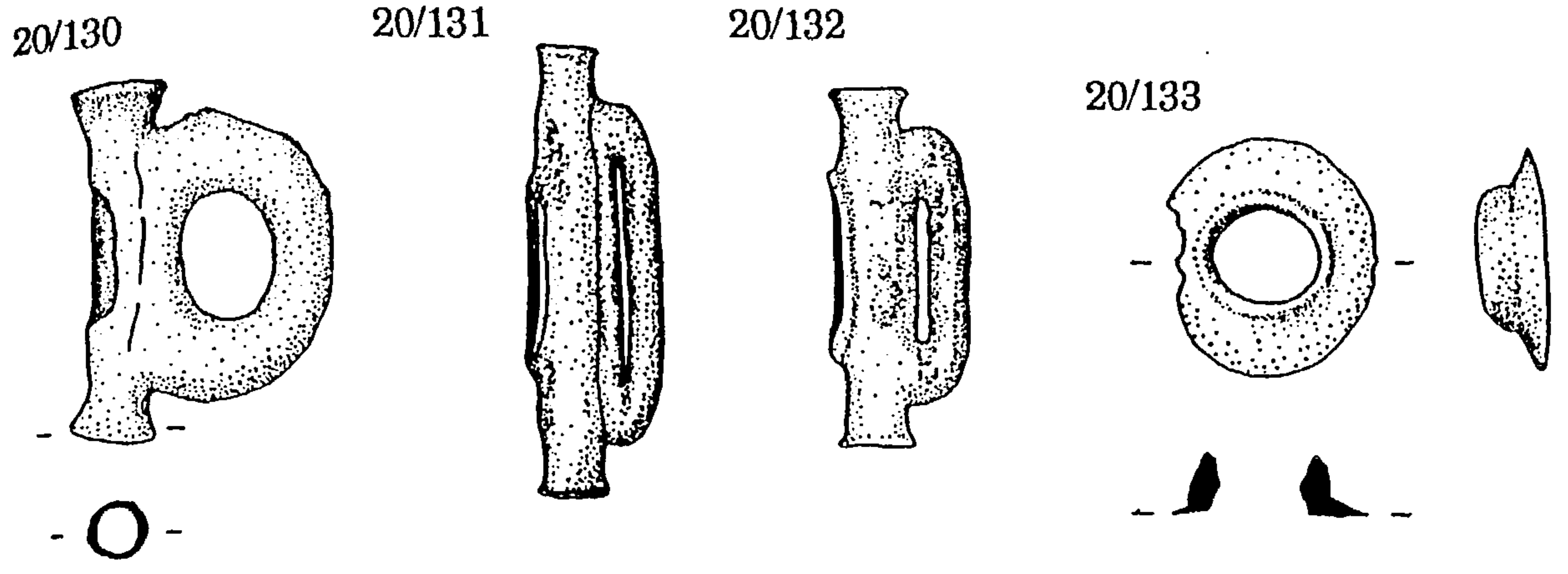
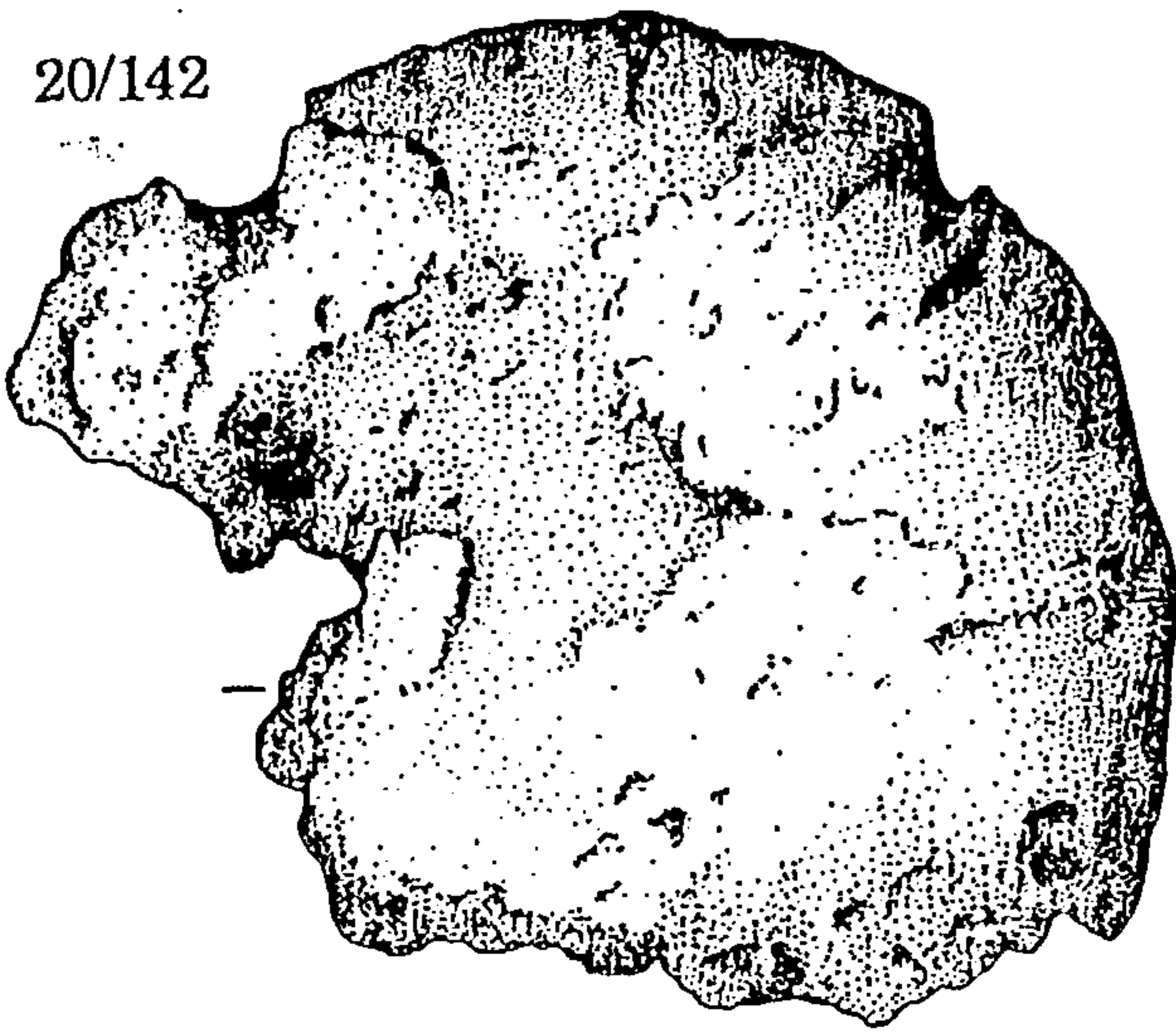
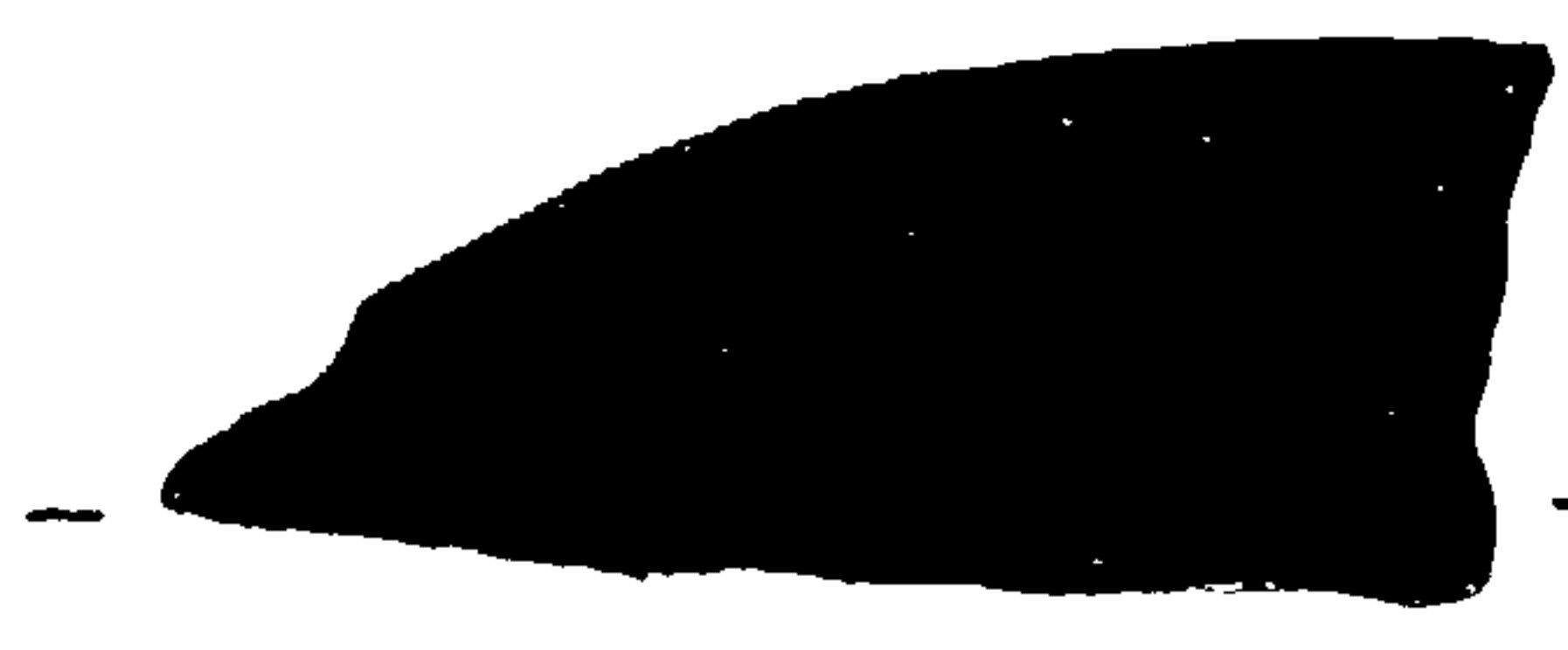
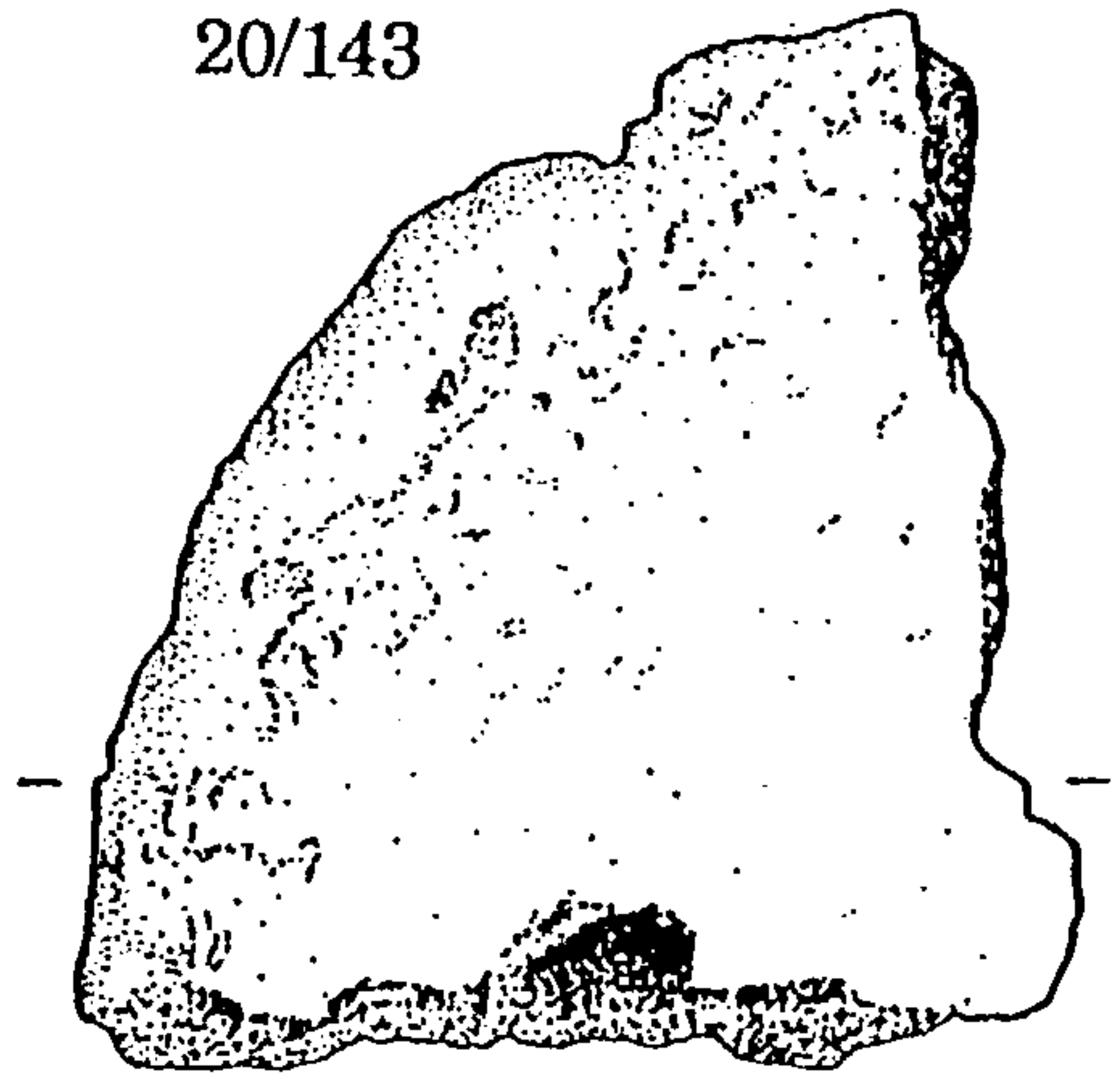


Fig. 72: The Minster Hoard (Ref. No. 20): Miscellaneous Objects and Casting Debris

20/142



20/143



0 2cm

20/144



20/145

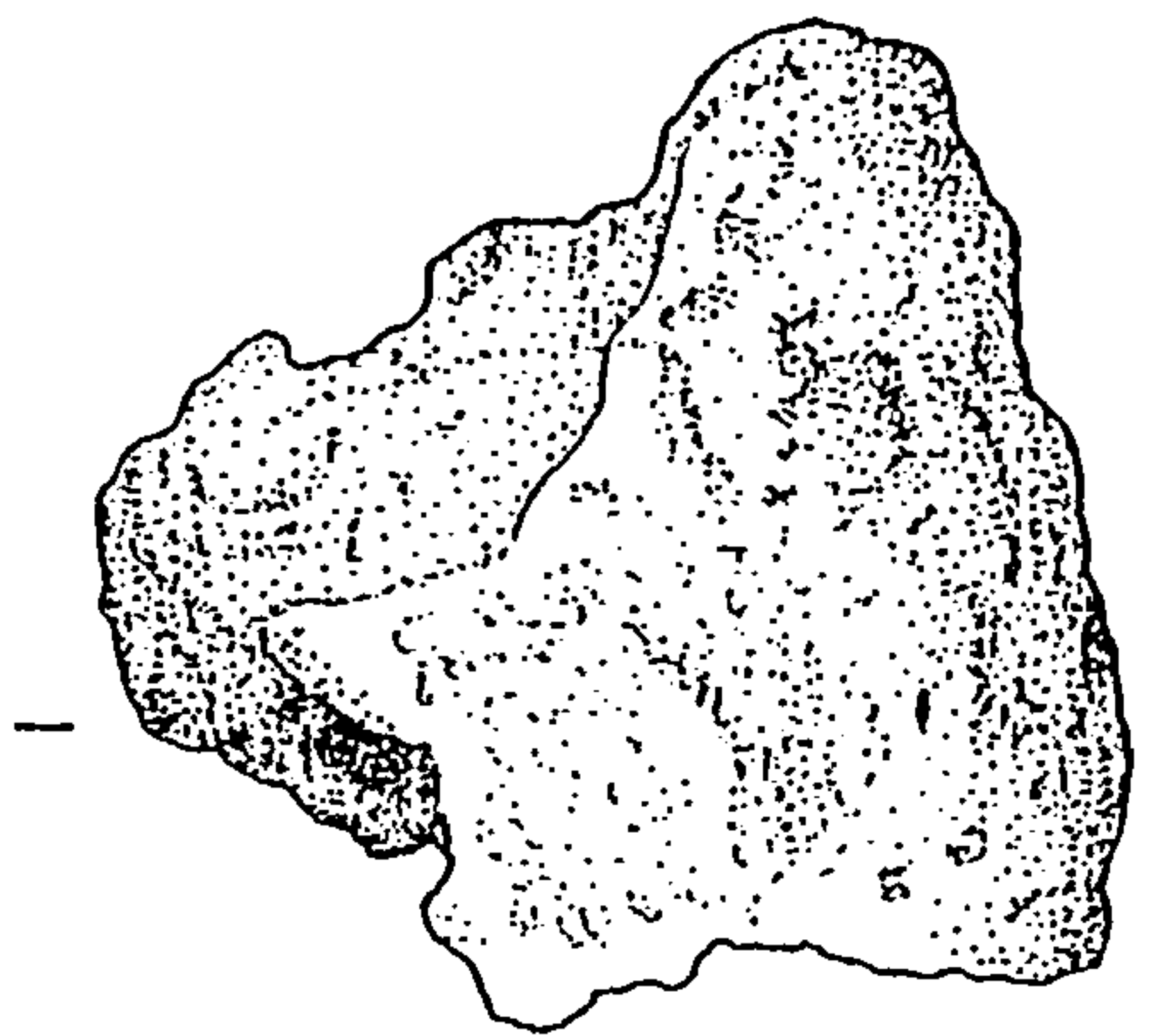
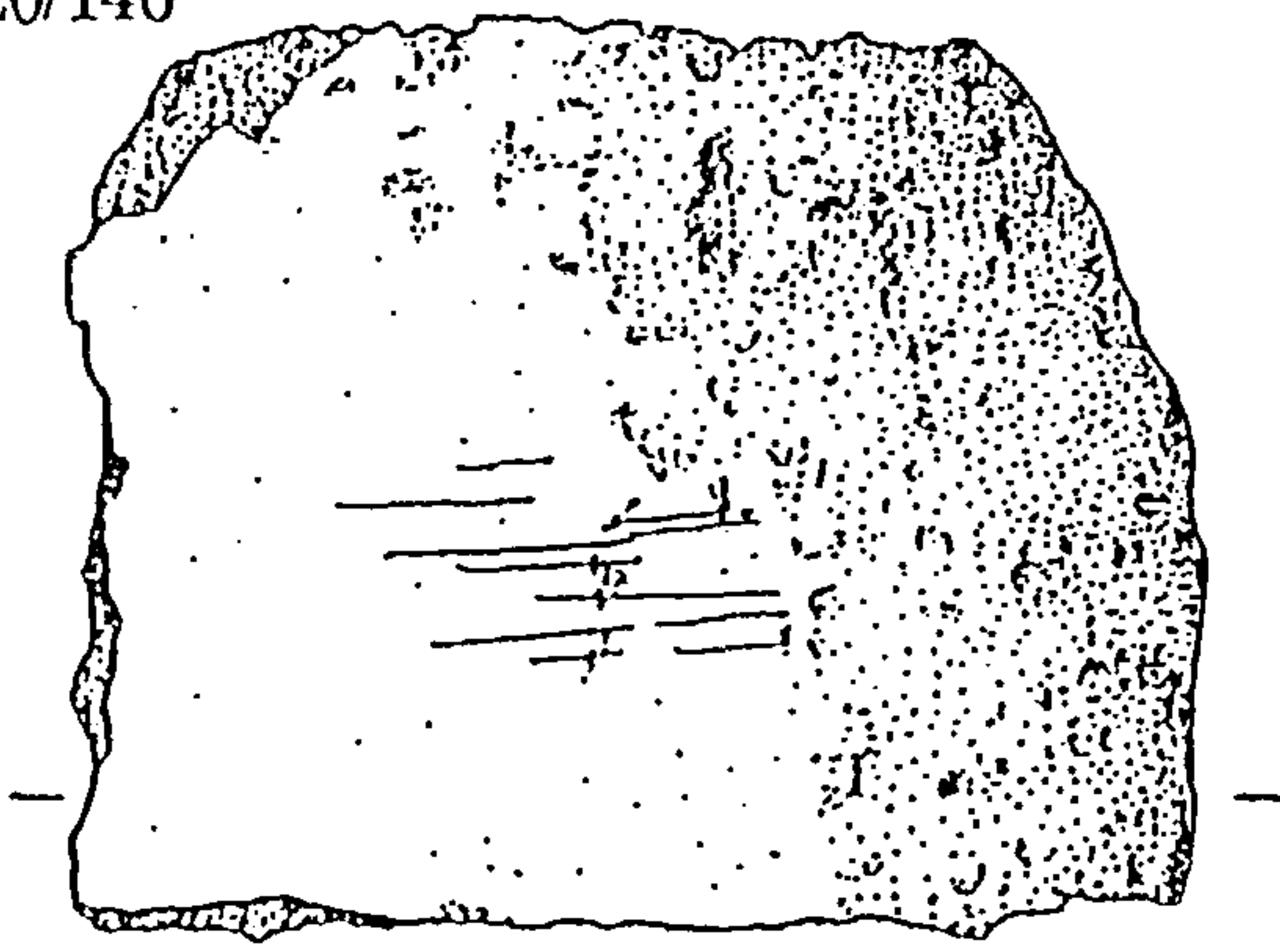
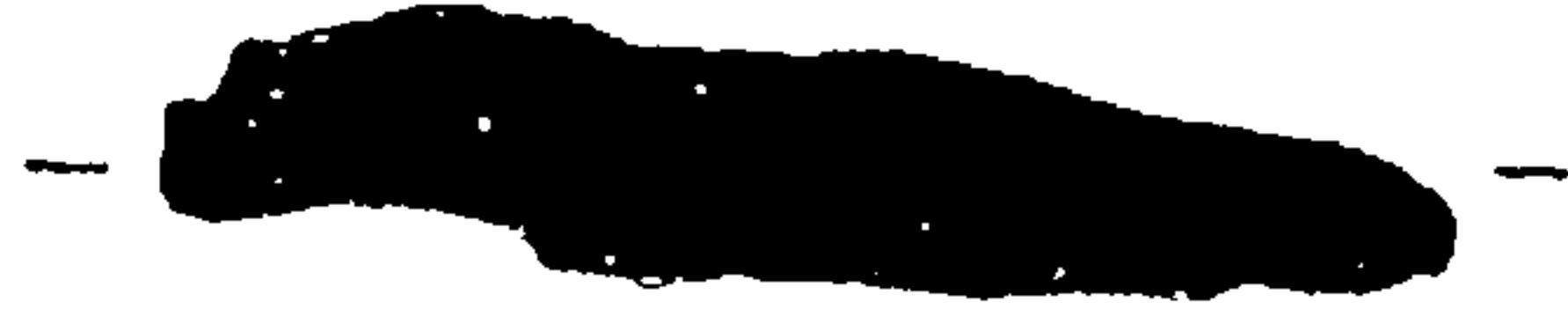
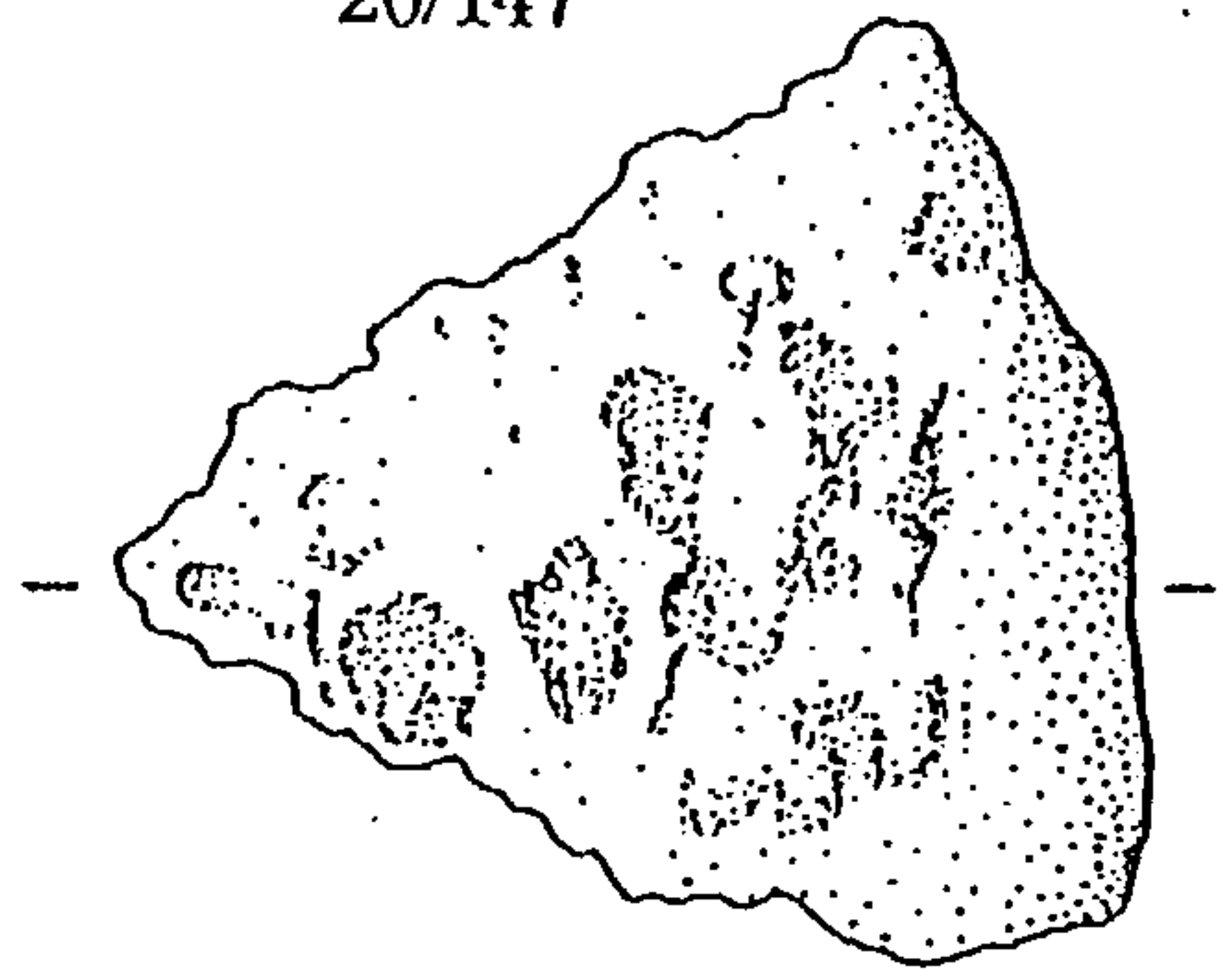


Fig. 73: The Minster Hoard (Ref. No. 20): Ingot Metal (i)

20/146

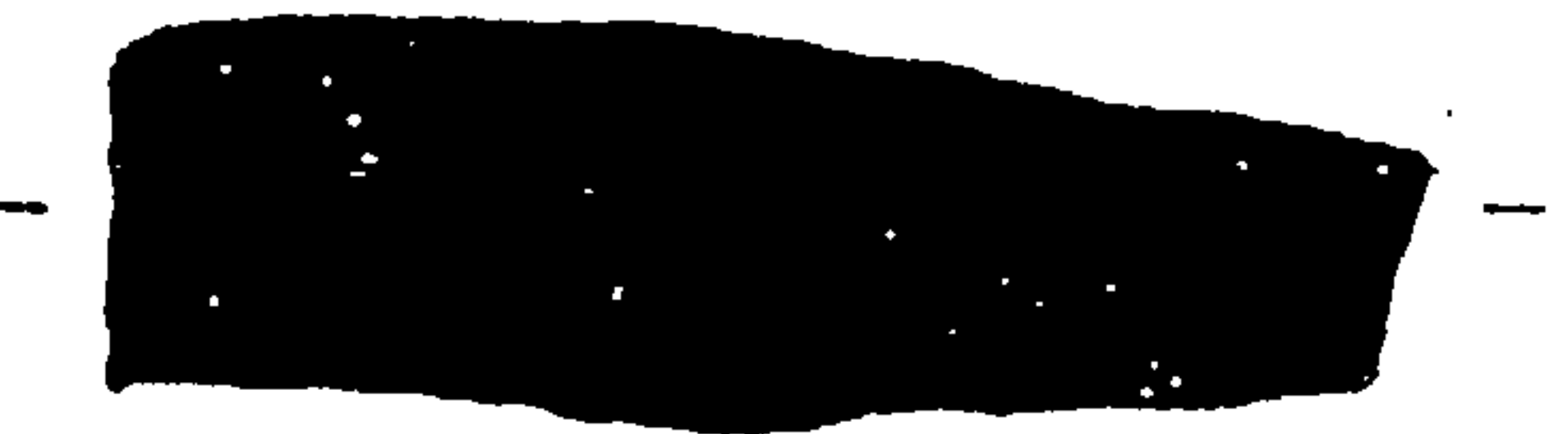
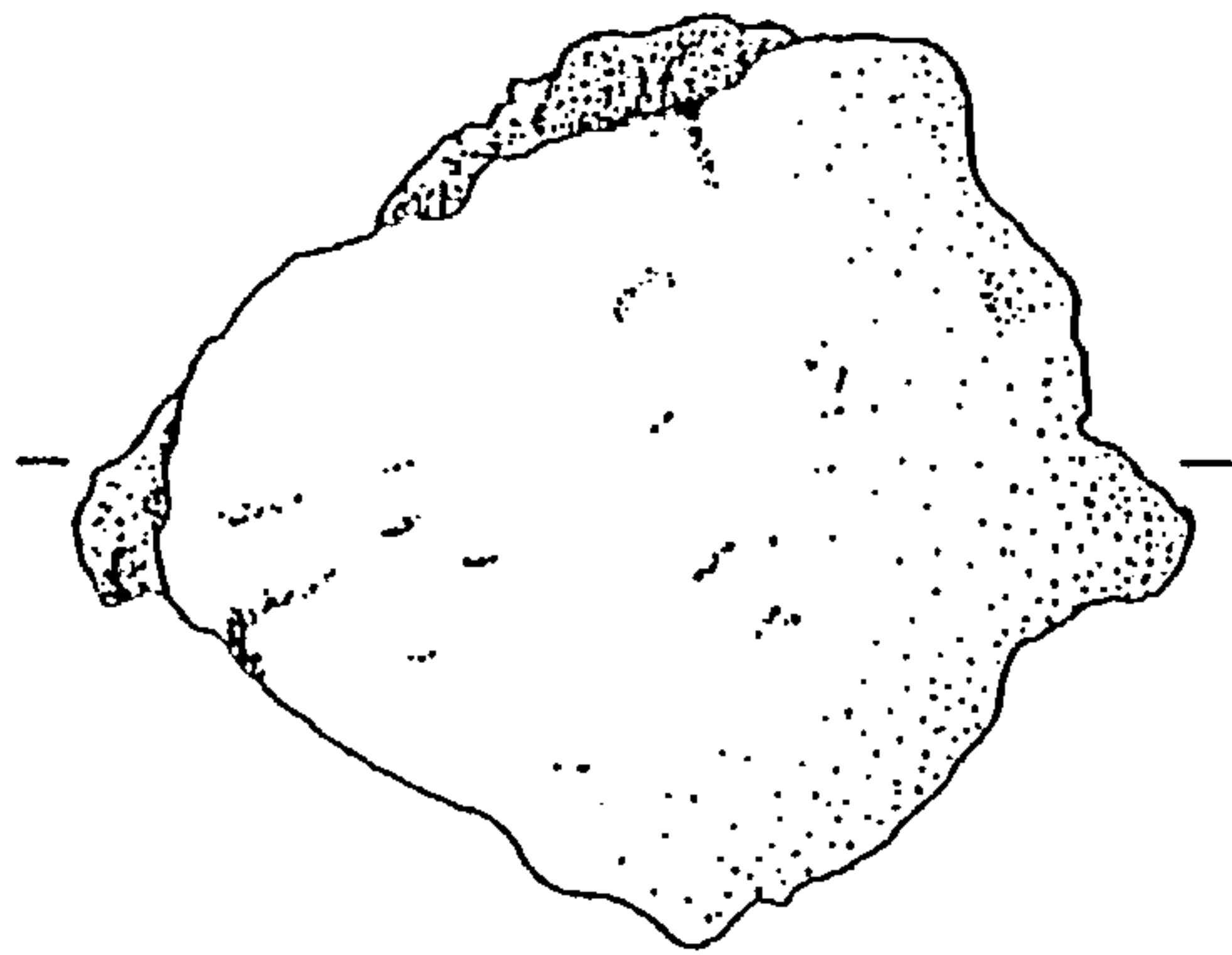


20/147



0 2cm

20/148



20/149

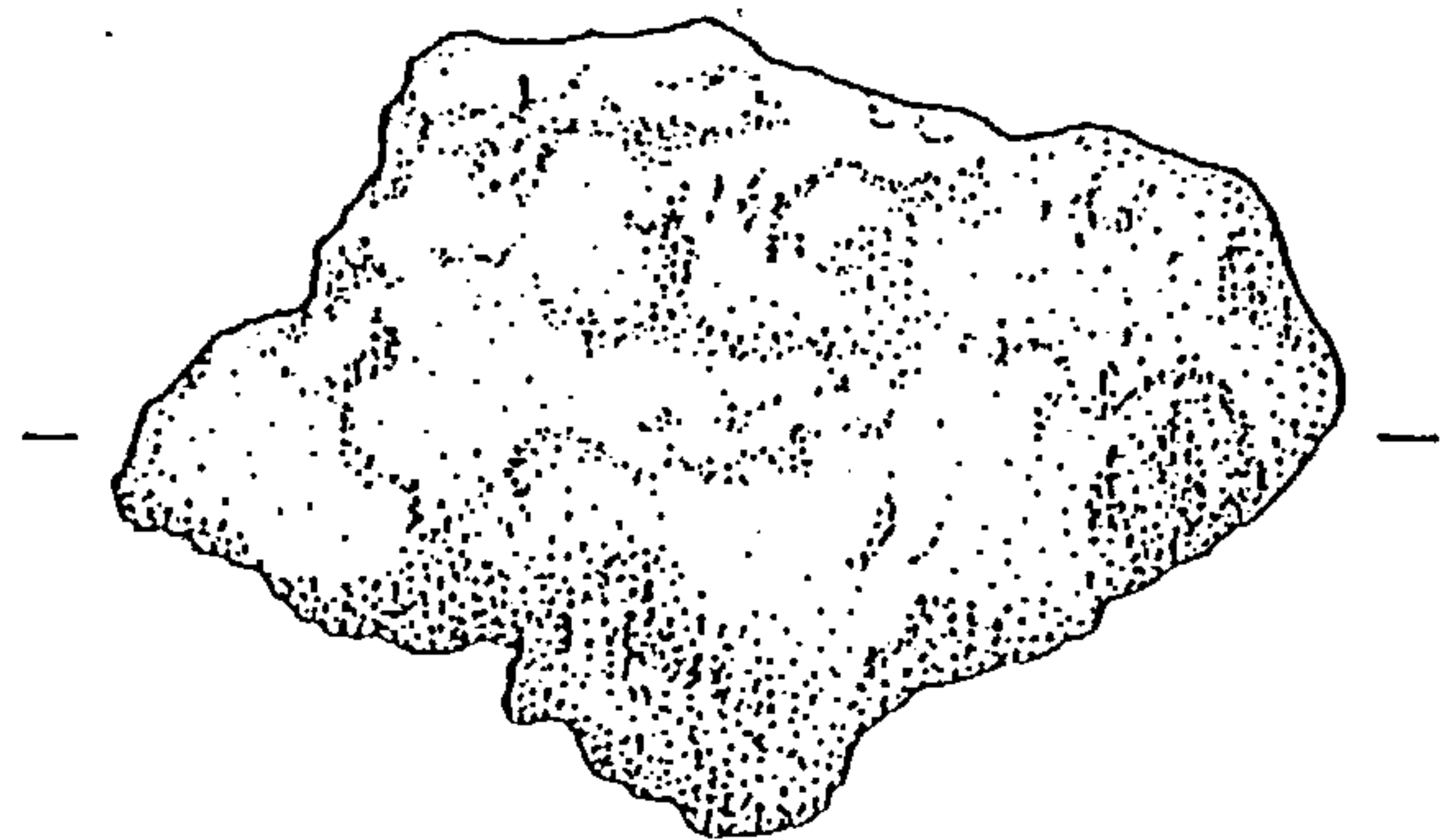
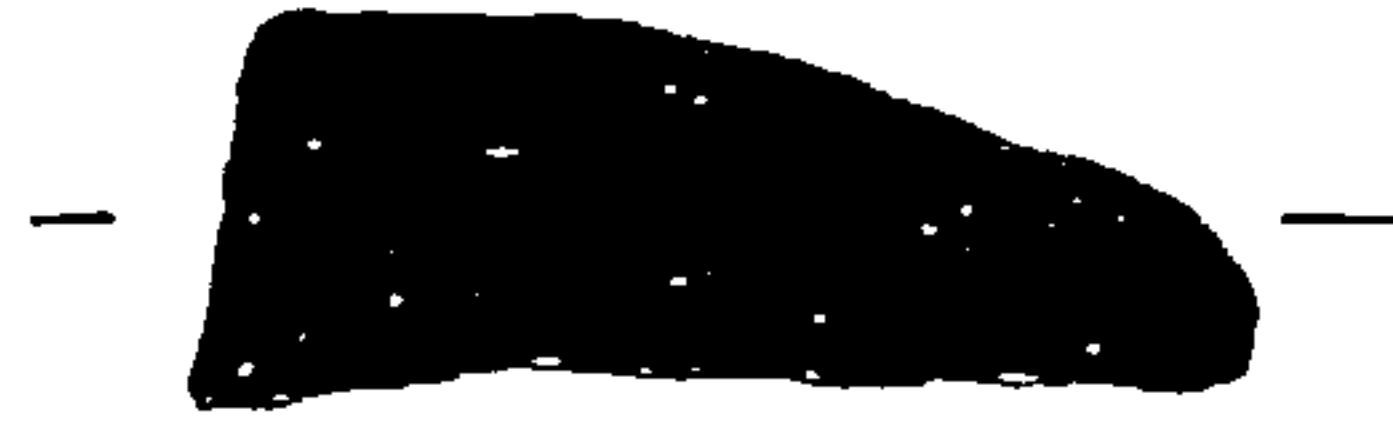
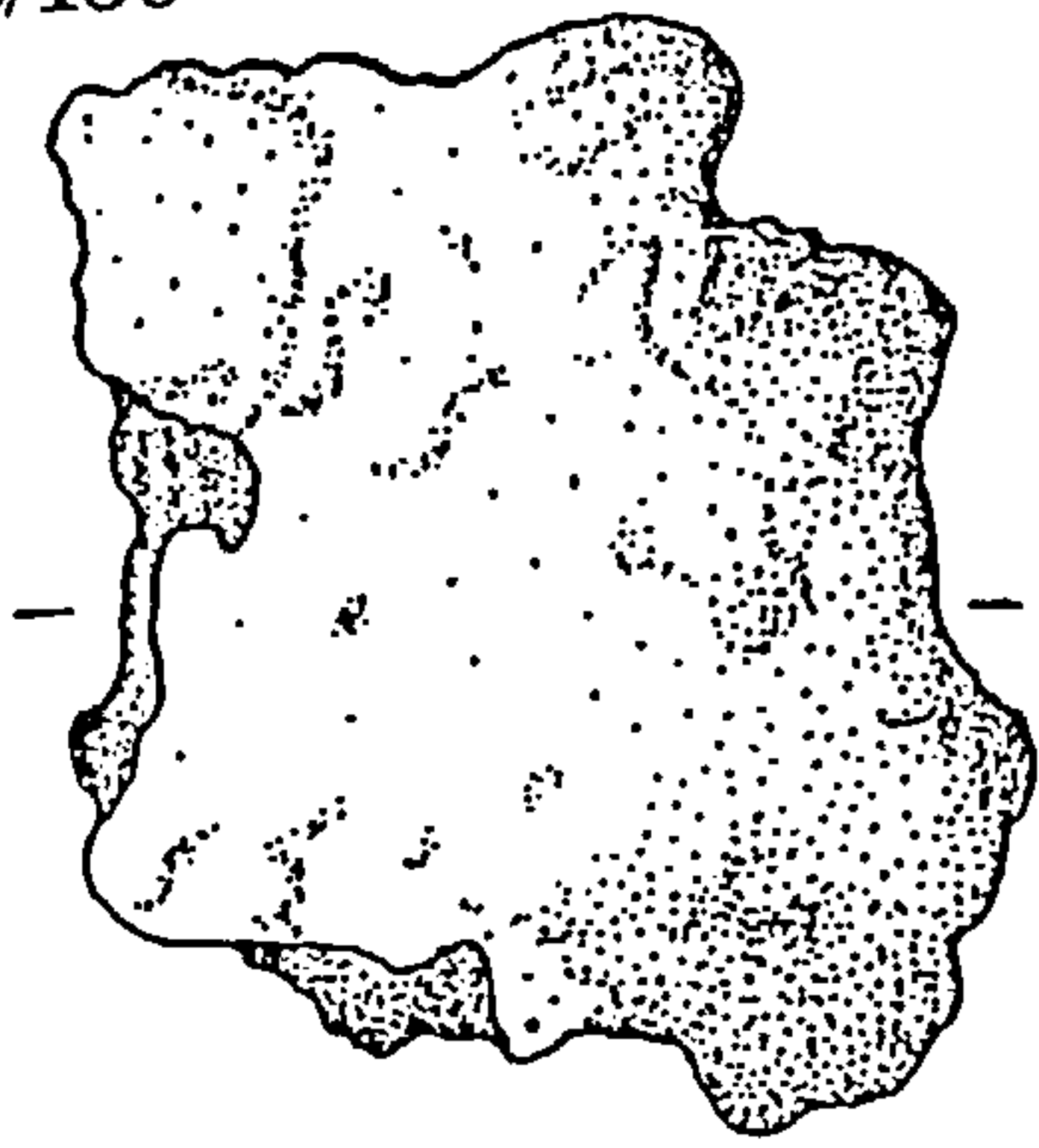
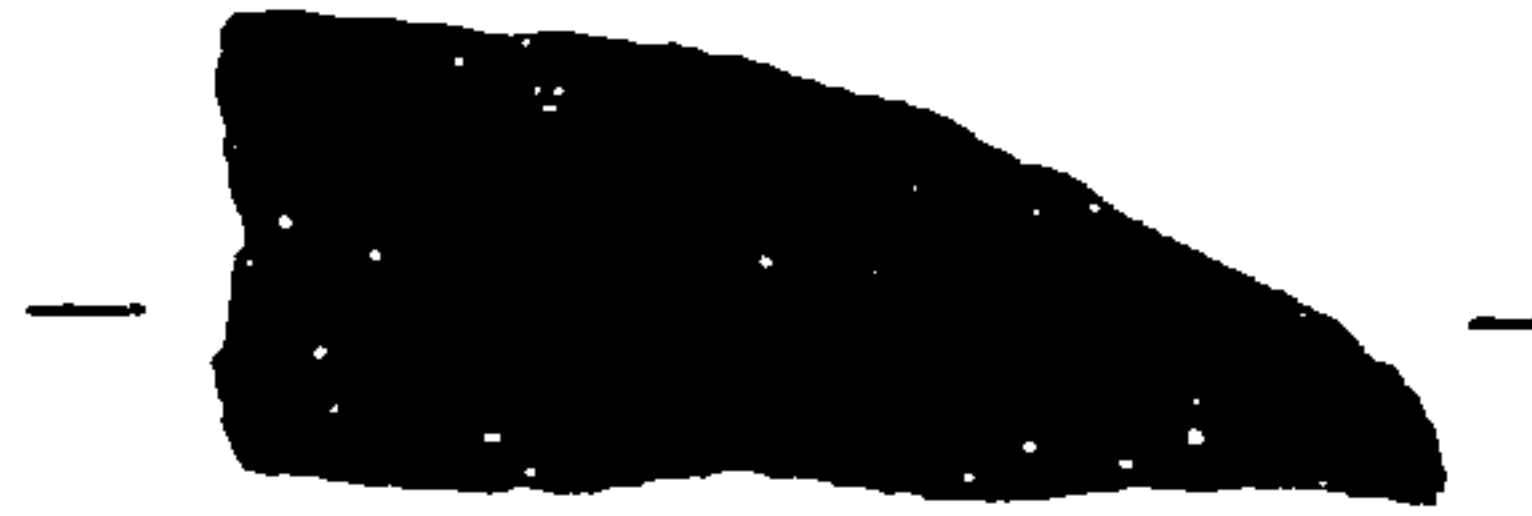
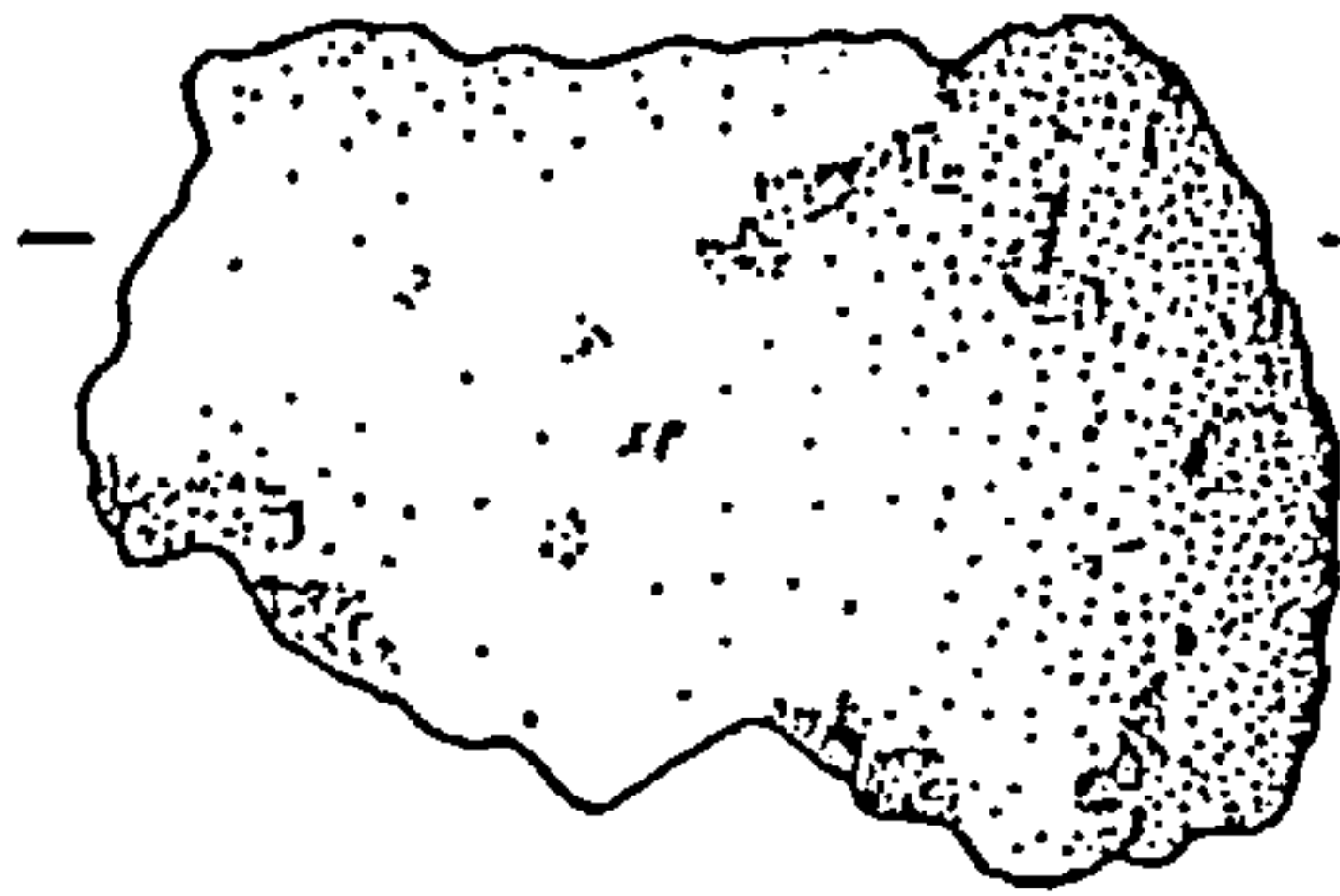


Fig. 74: The Minster Hoard (Ref. No. 20): Ingot Metal (ii)

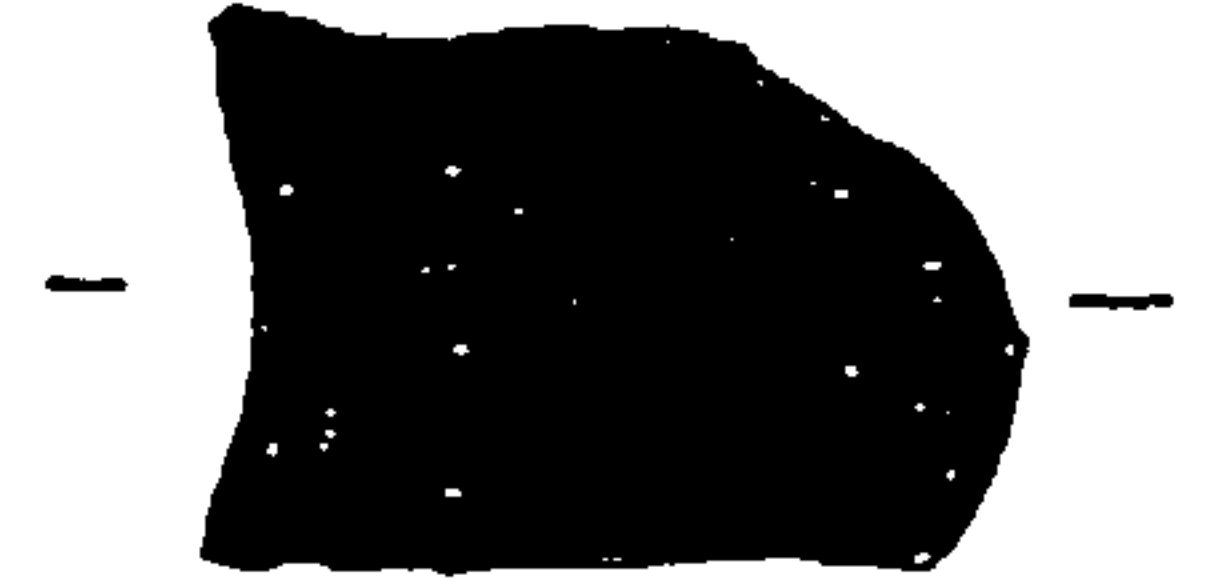
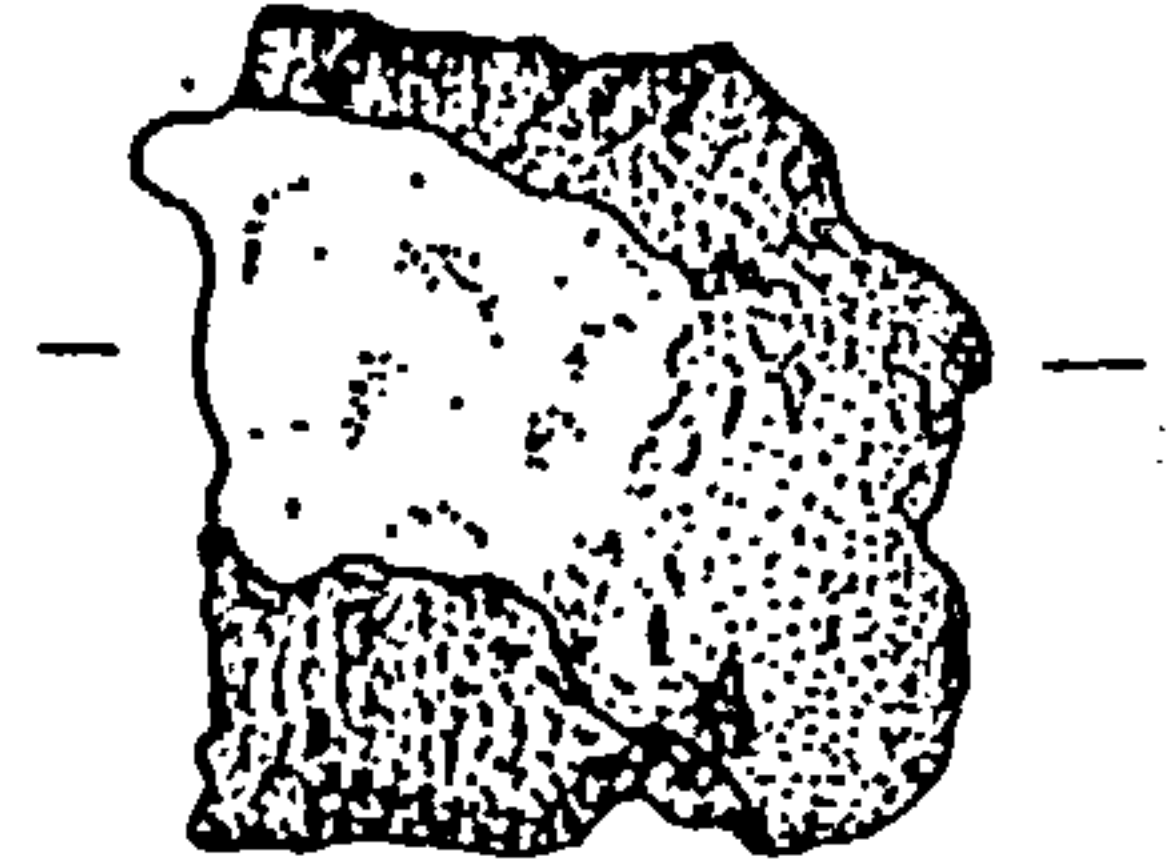
20/150



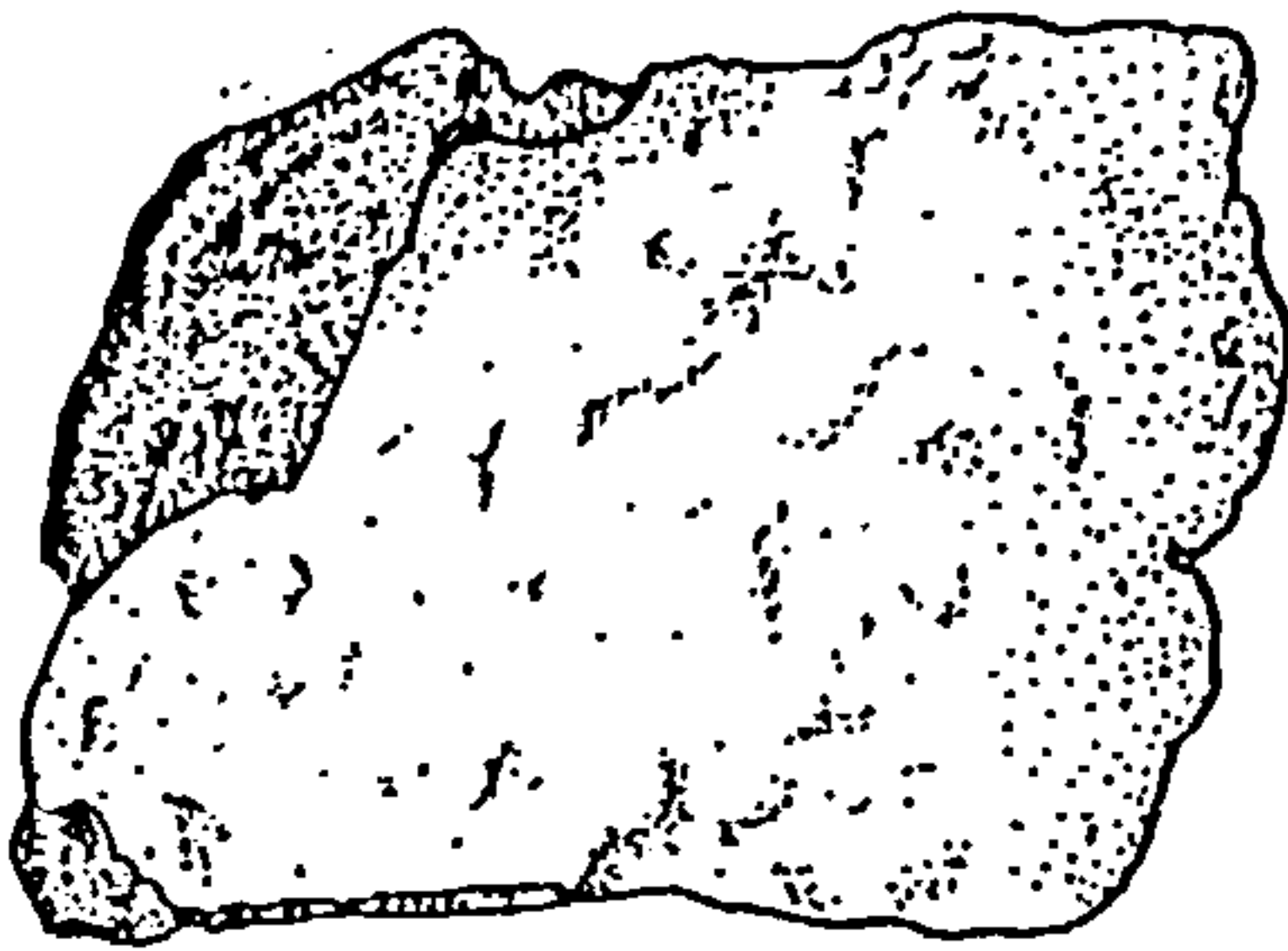
20/151



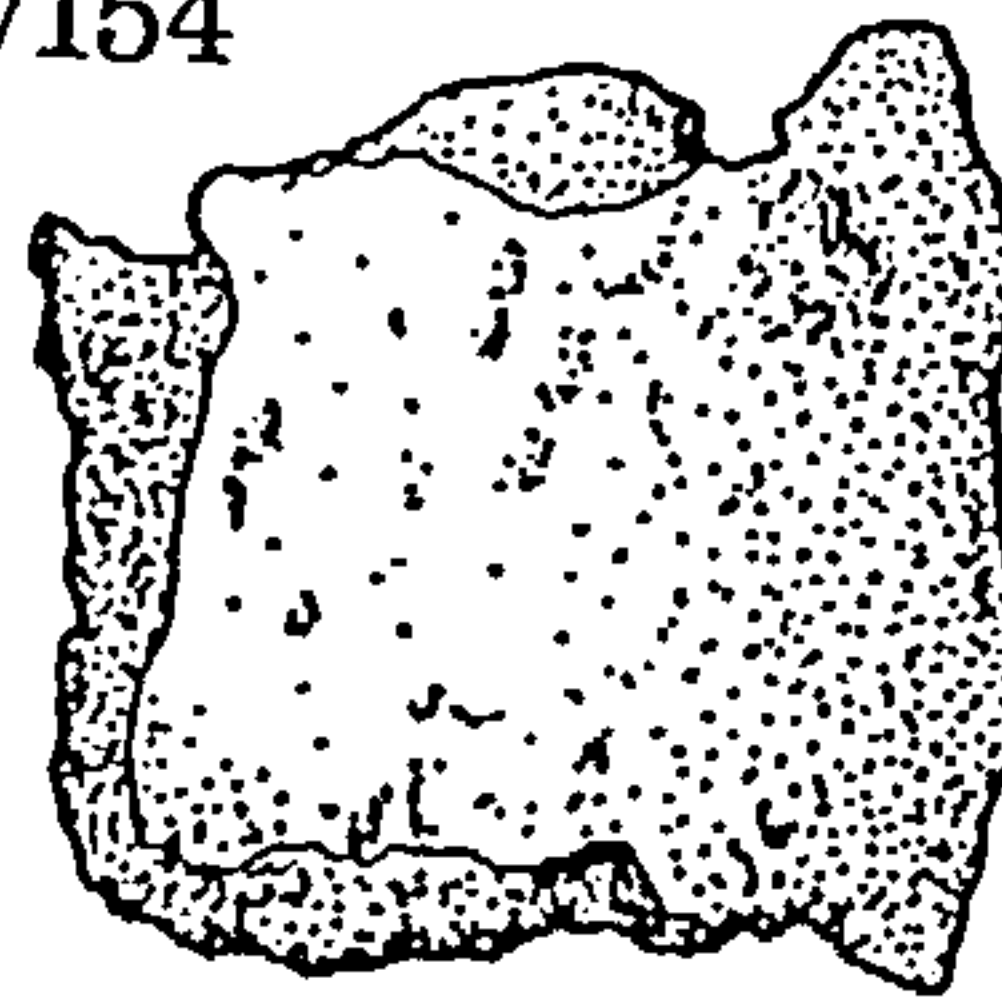
20/152



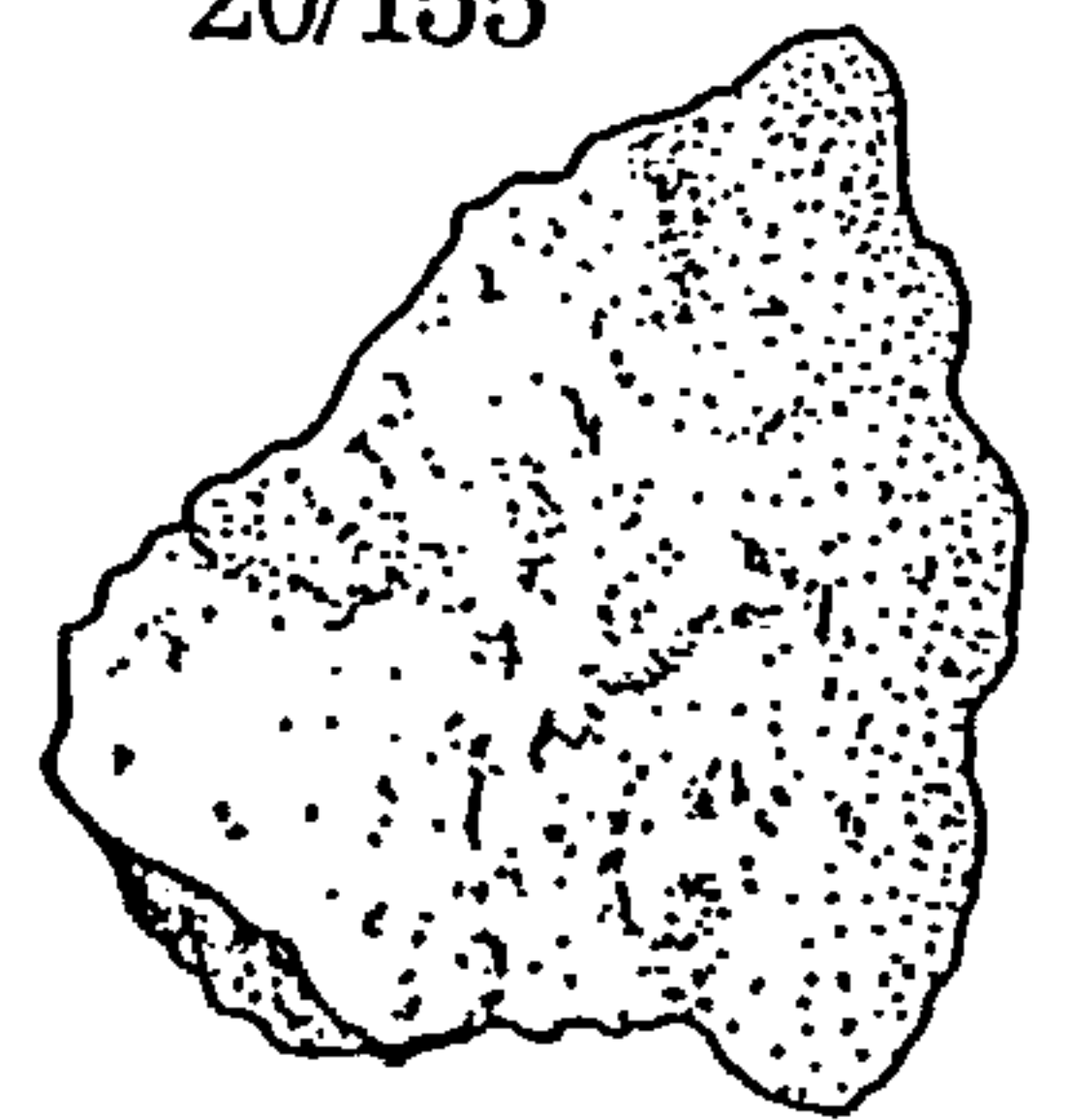
20/153



20/154

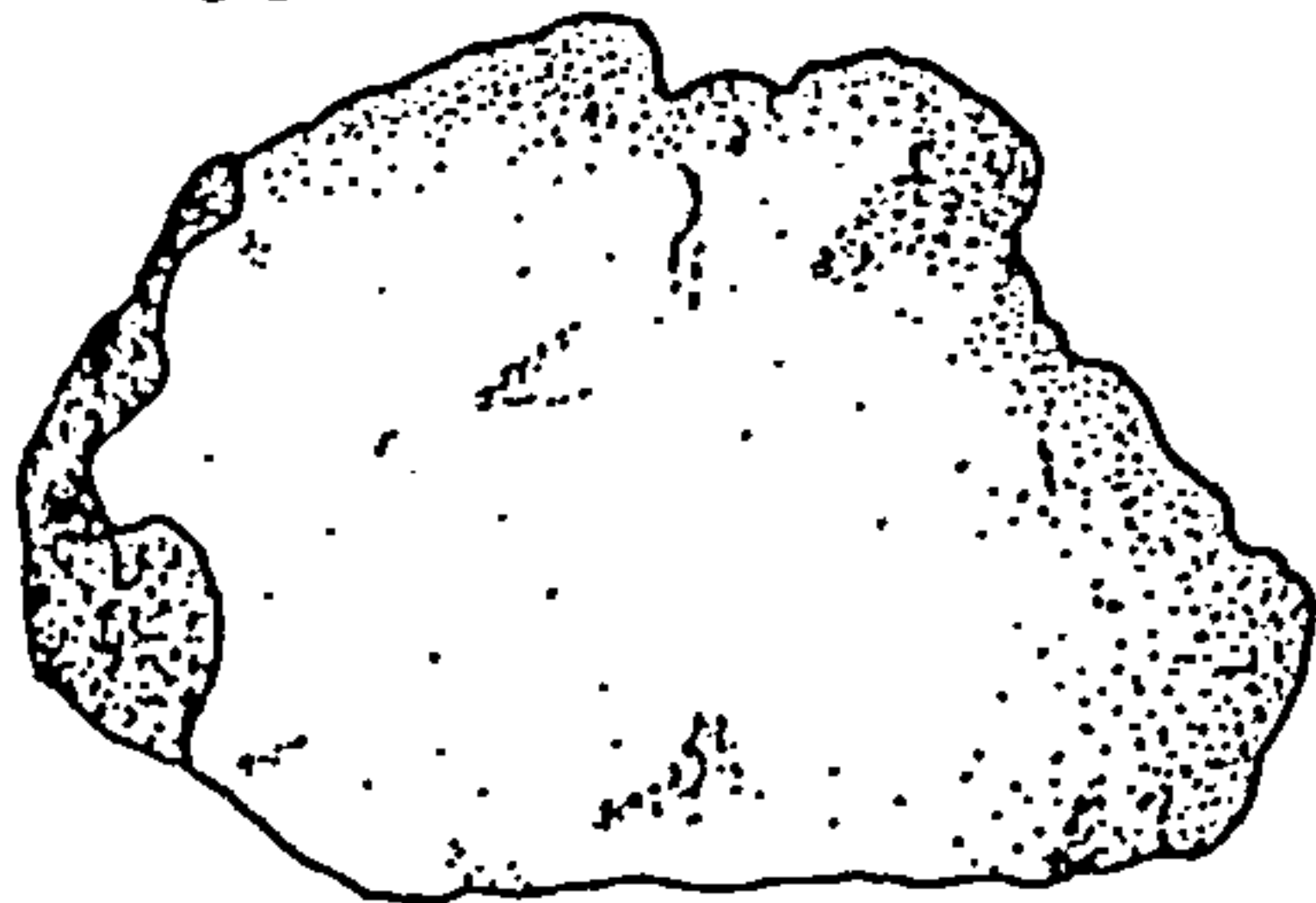


20/155

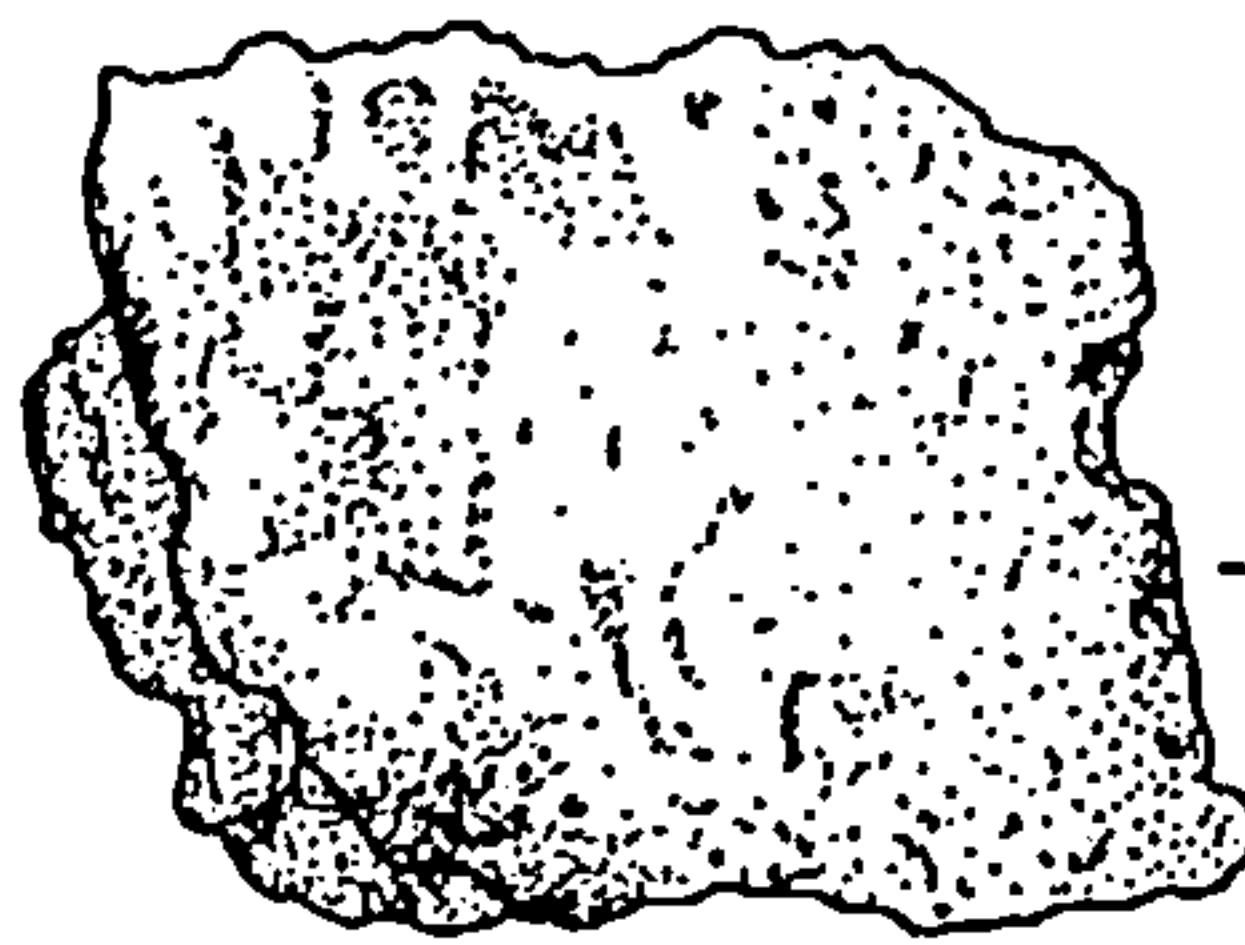


0 2cm

20/156



20/157



20/158

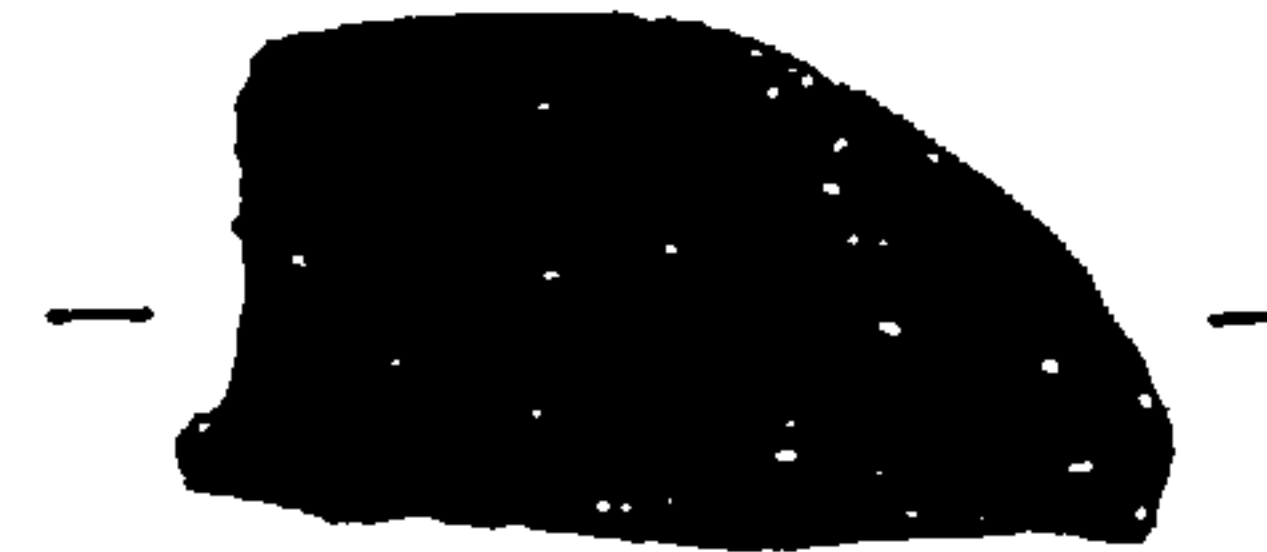
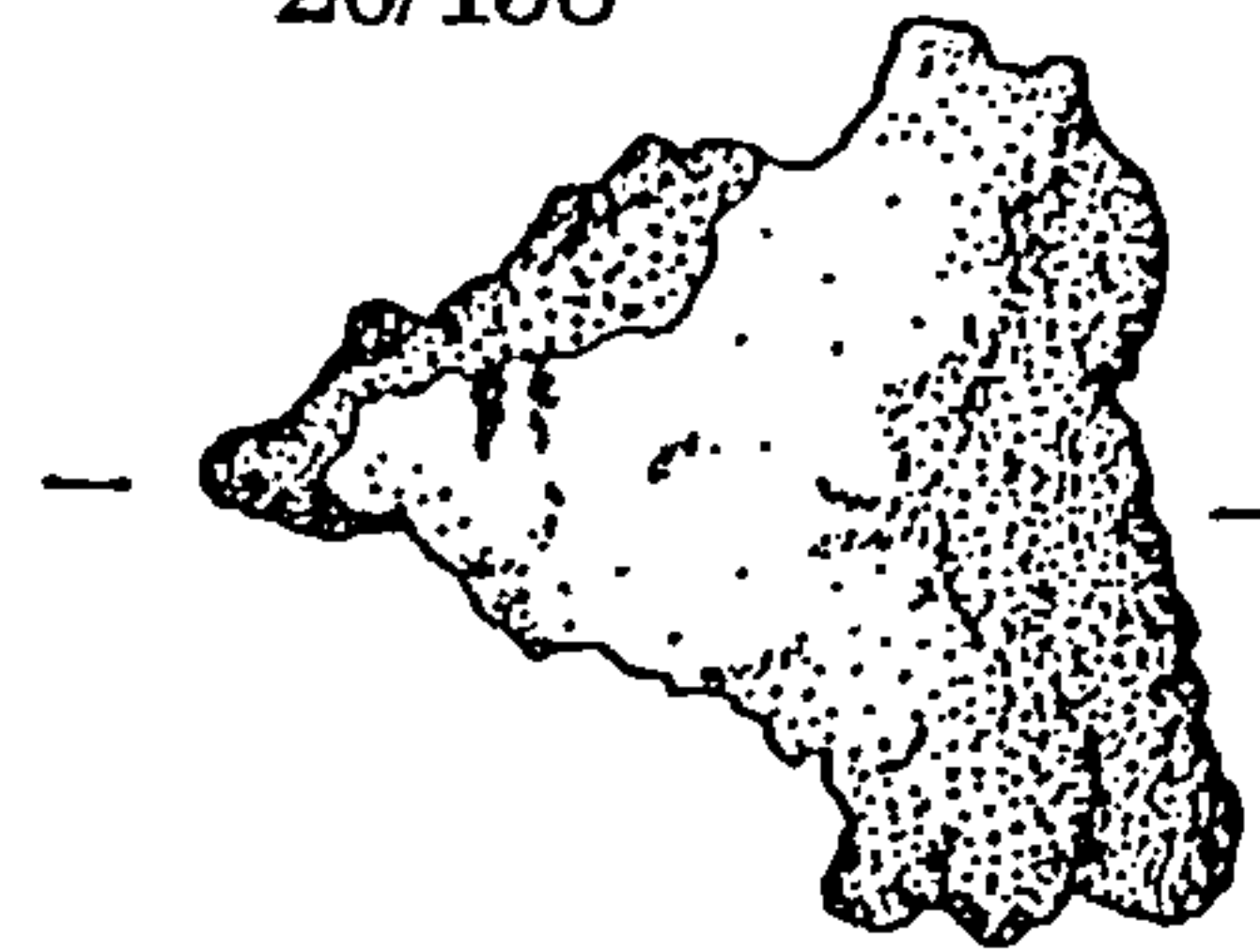
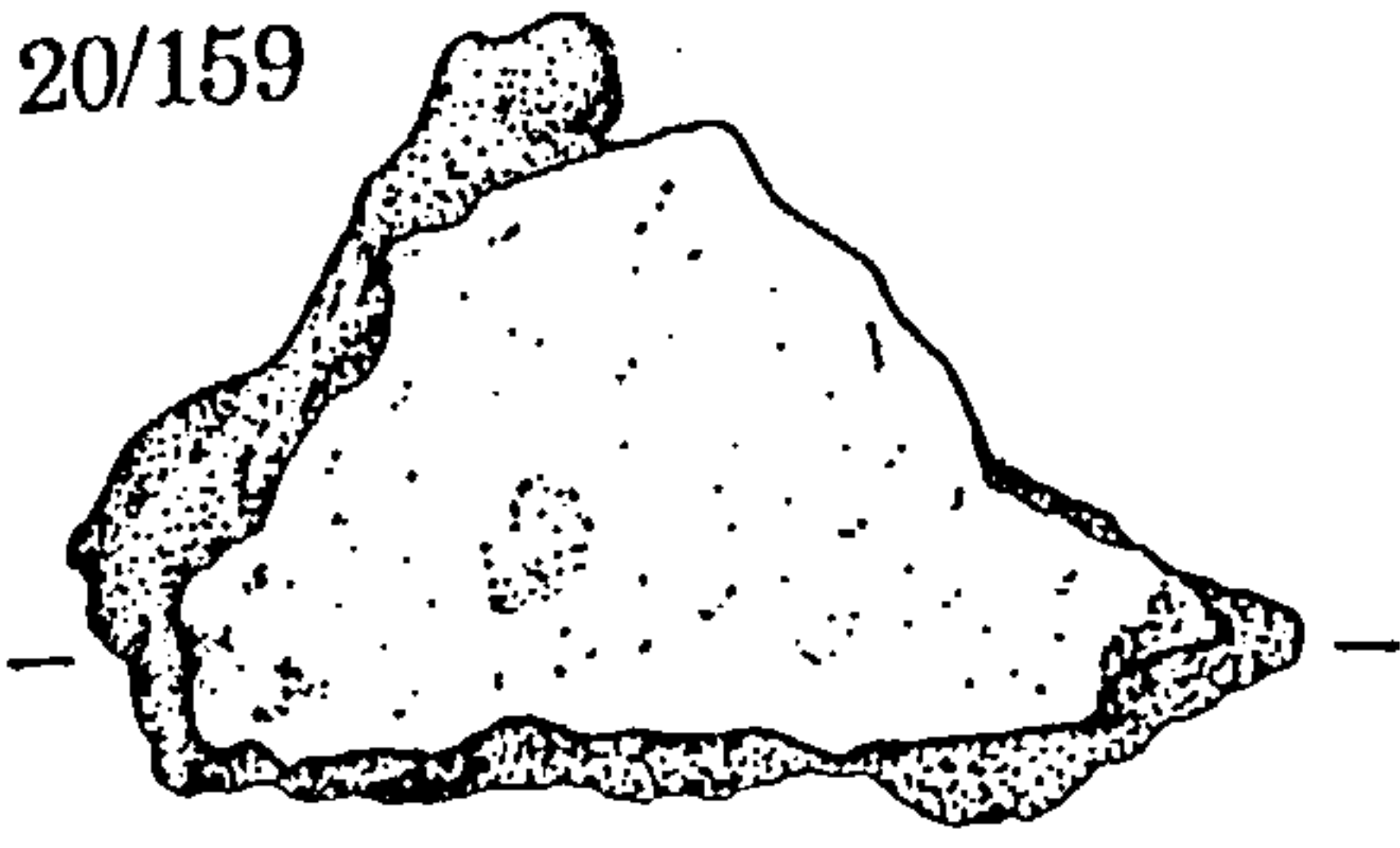
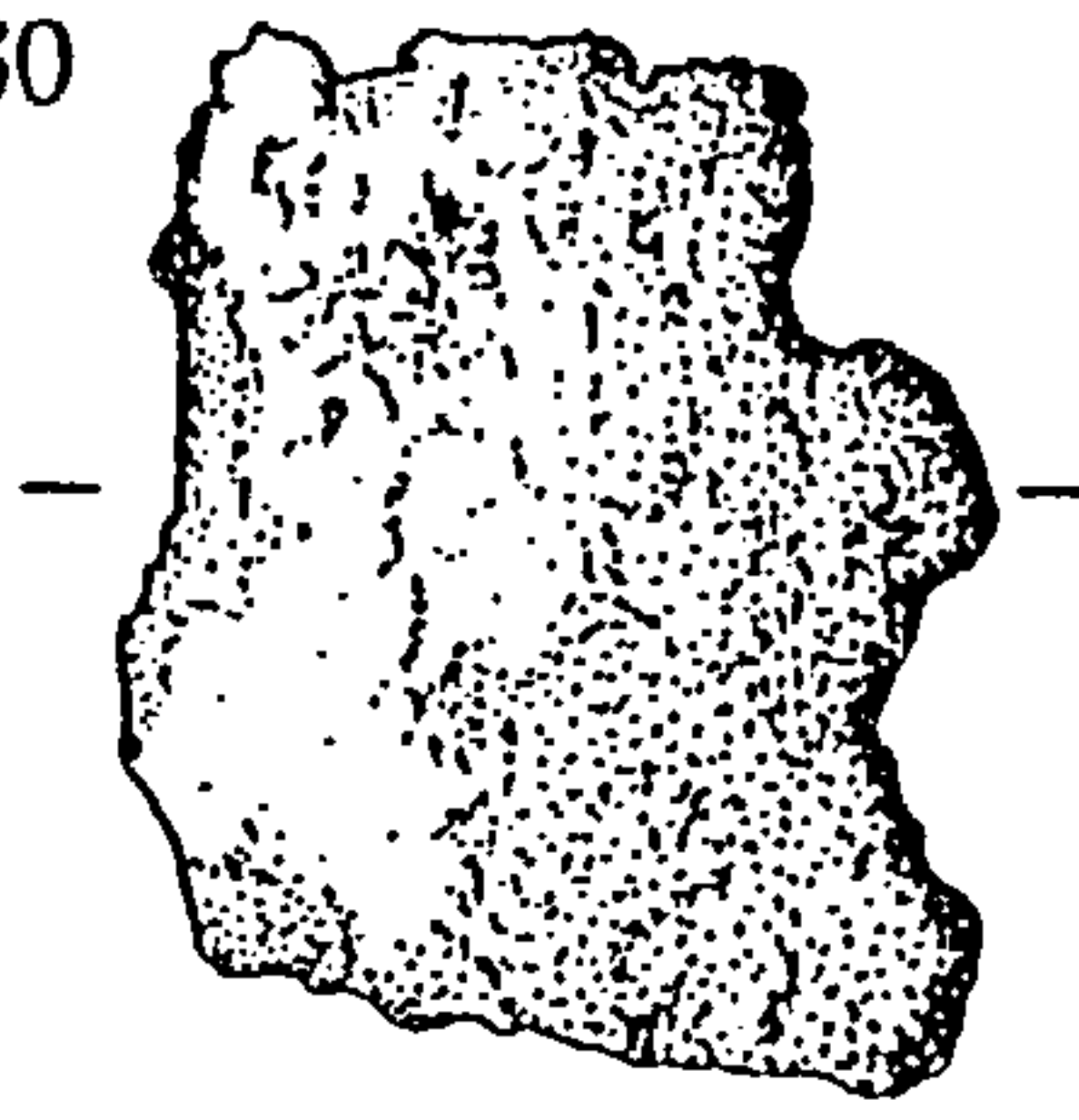


Fig. 75: The Minster Hoard (Ref. No. 20): Ingot Metal (iii)

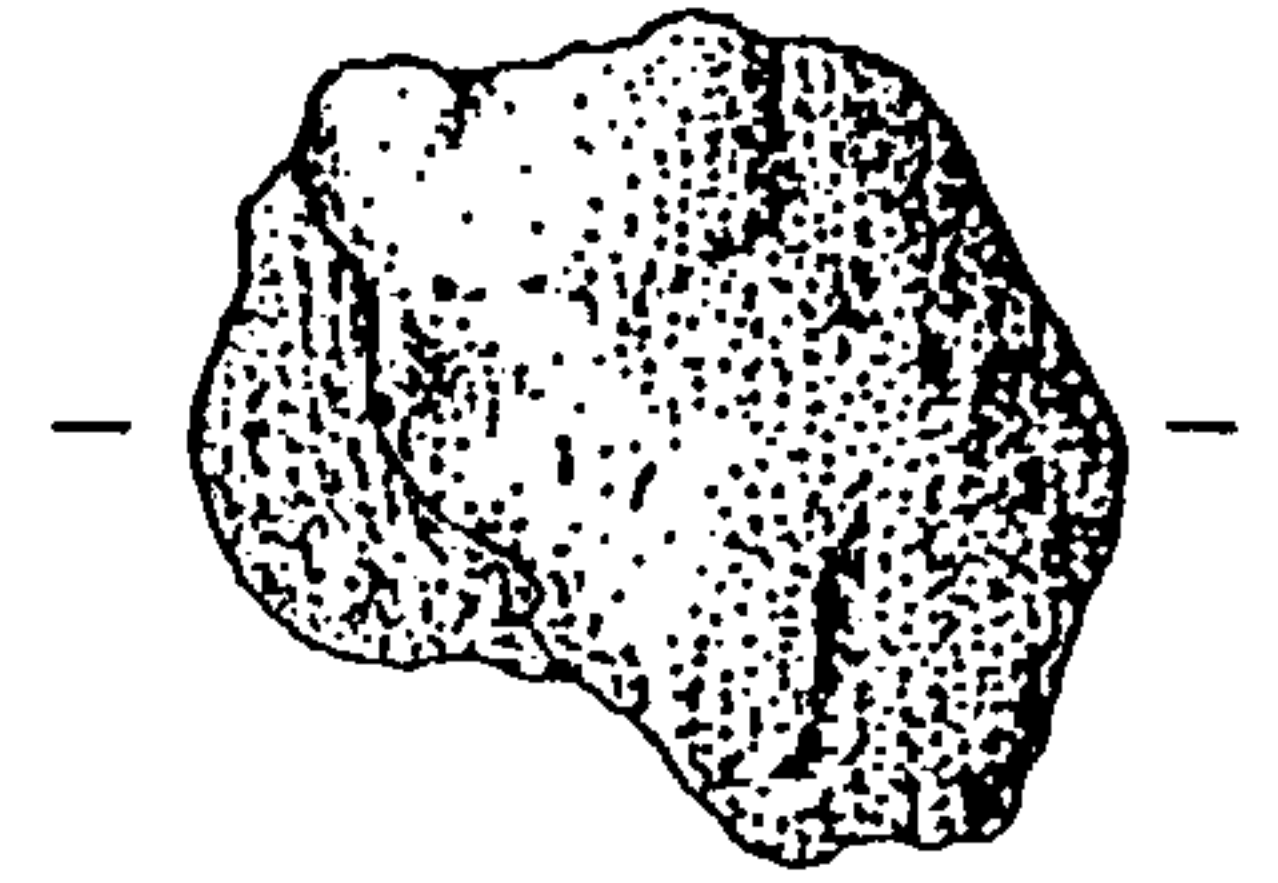
20/159



20/160

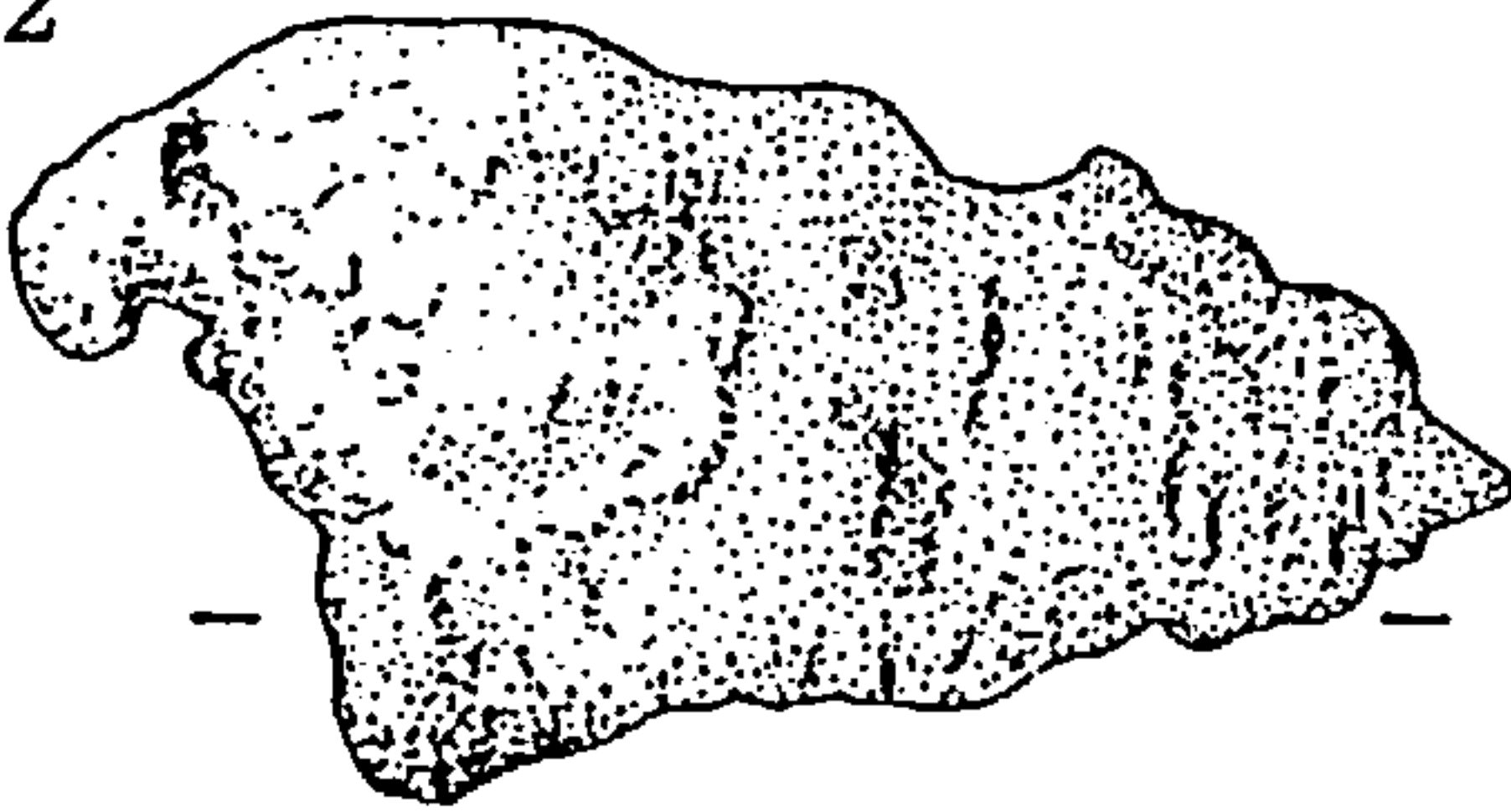


20/161



0 2cm

20/162



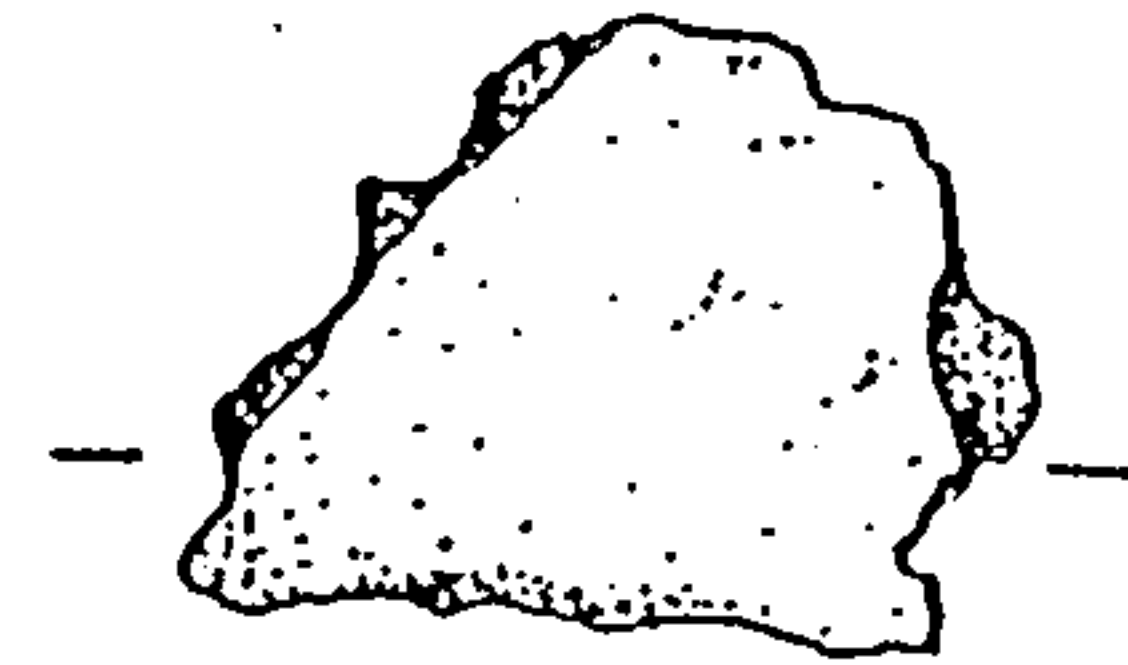
20/163



20/164



20/165



20/166

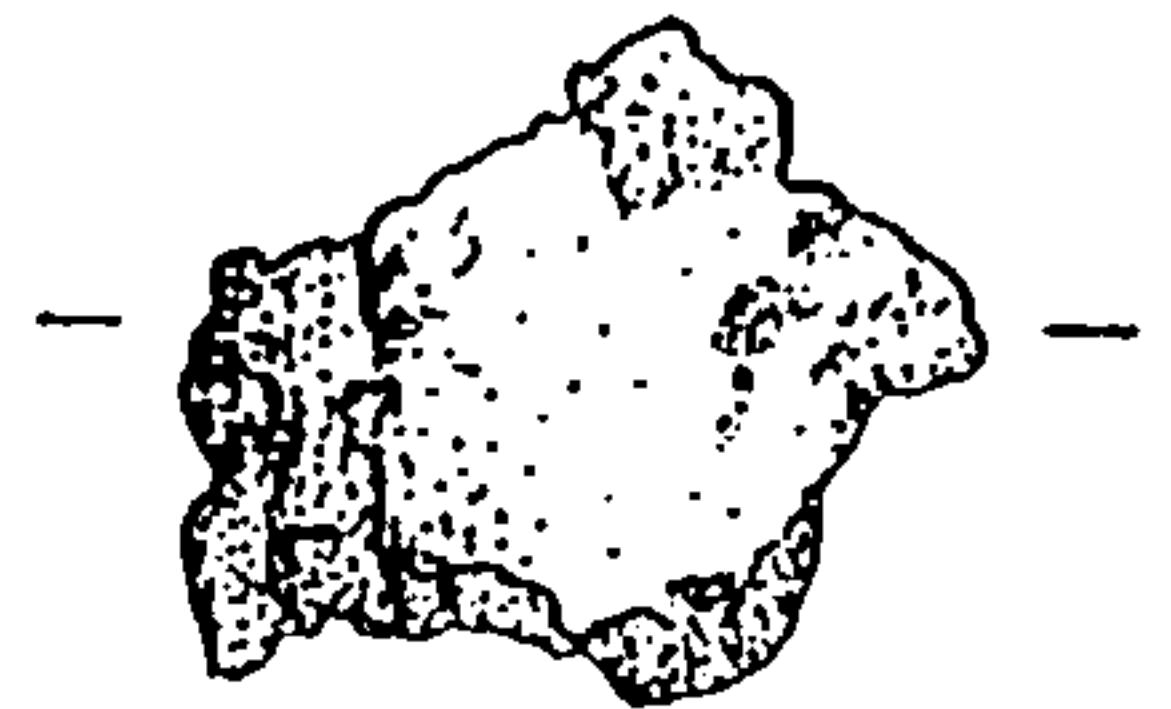
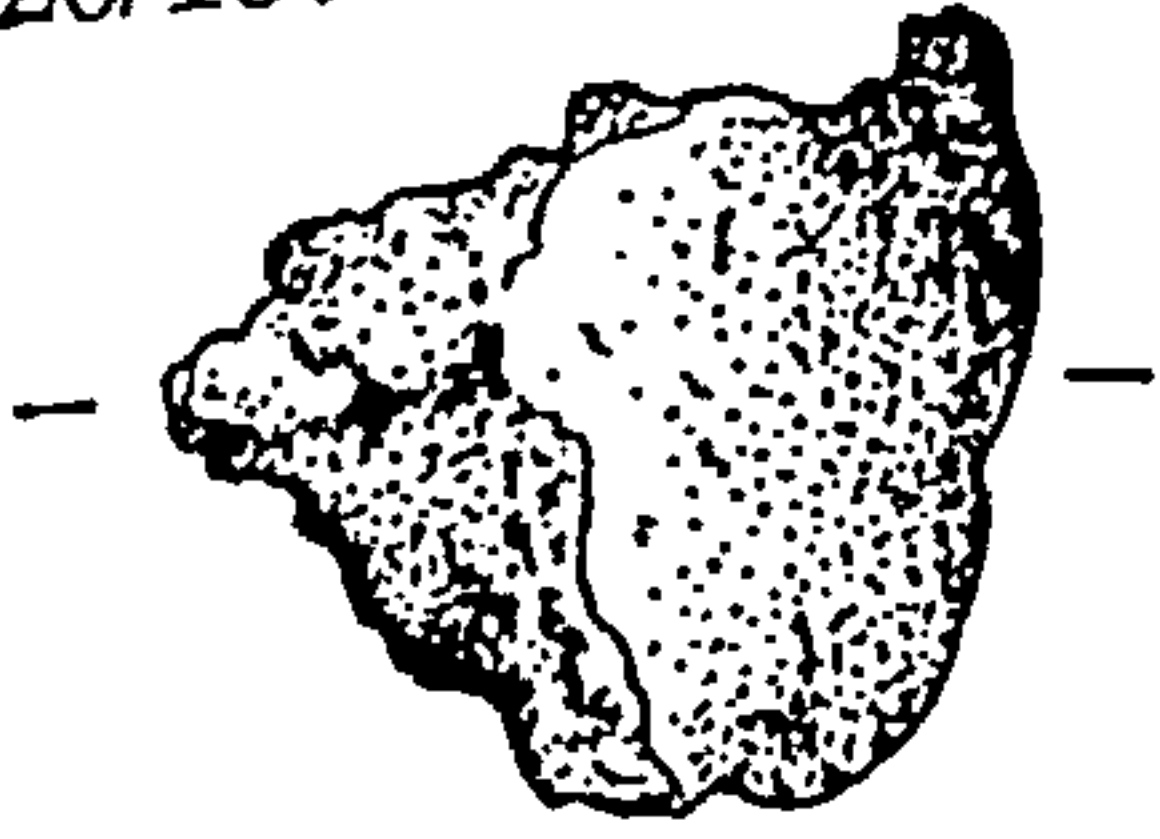


Fig. 76: The Minster Hoard (Ref. No. 20): Ingot Metal (iv)

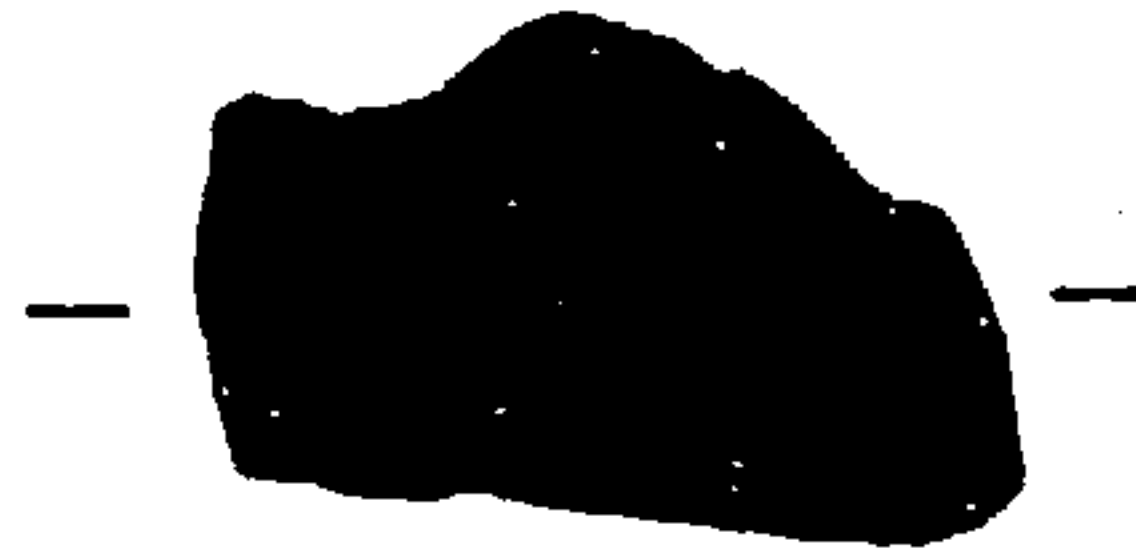
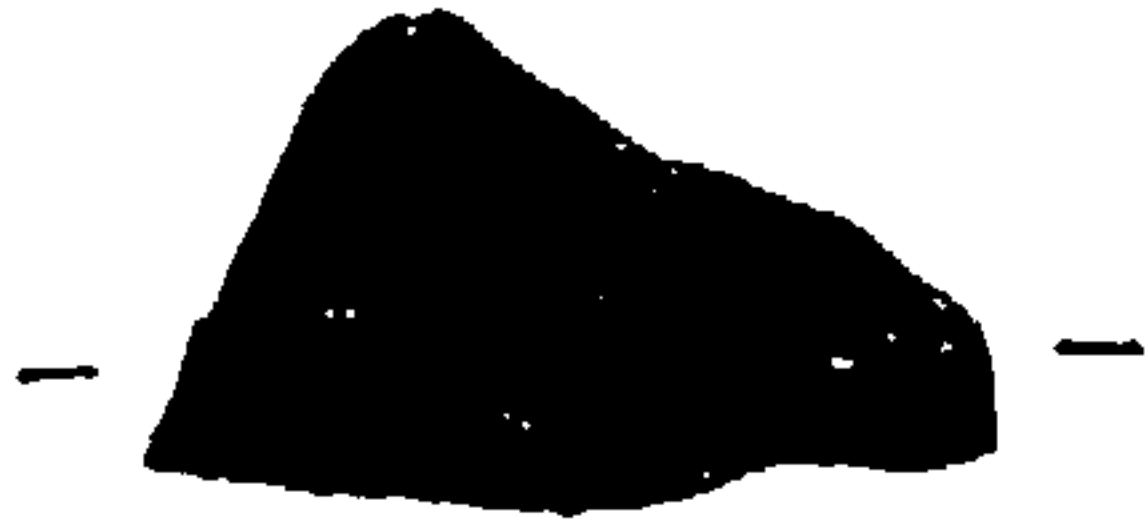
20/167



20/168

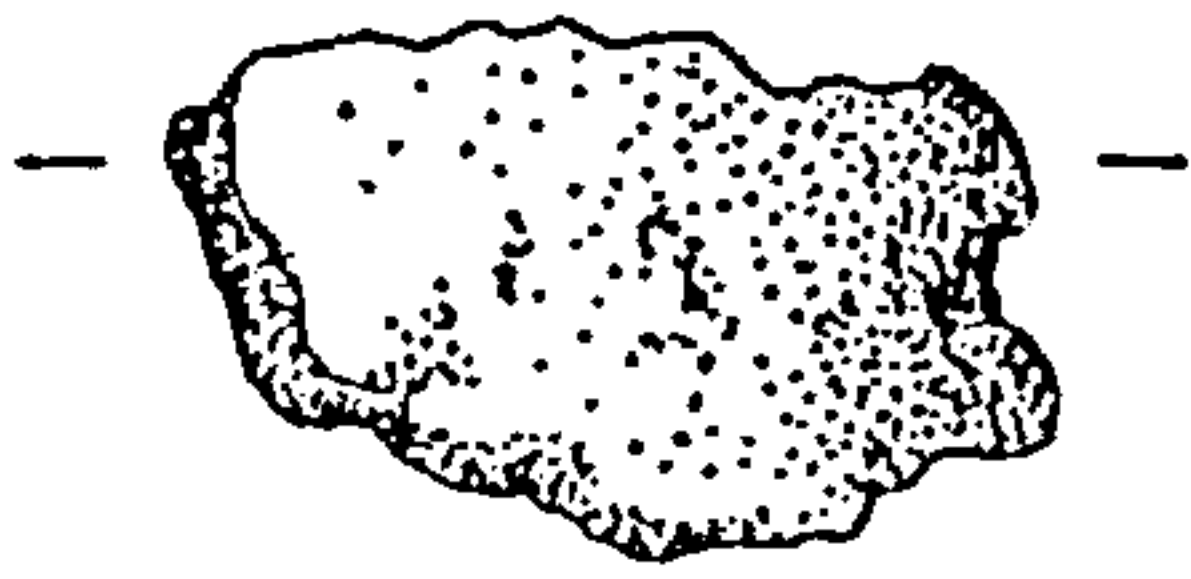


20/169



0 2cm

20/170



20/171



Fig. 77: The Minster Hoard (Ref. No. 20): Ingot Metal (v)

Stoke-at-Hoo (Ref. No. 21)

Grid Reference: TQ 82 75.

Current location: British Museum, Accession Numbers 93:2-5: 1-50.

Context: No details known.

Bibliography: Burgess and Colquhoun, 1988
N.B.I.

Contents:-

21/01 (Acc. No. 93: 2-5: 11)

Description: Facetted socketed axe.

Dimensions: Length: 99mm. Cutting edge (maximum): 49mm. Weight: 147.7g.

Patina: Rough green-brown, details locally reasonable.

Manufacture: The feeders and the intervening seam have been removed completely around the mouth, which remains rather rough in appearance. Over the body, the upper seam has been completely obliterated. The lower seam is similar, though it remains visible over the loop. Here, it appears to have been hammered flat and it may have been retained as a decorative feature. There are some horizontal grinding marks evident over the cutting edge, which has been widely expanded.

Use: The cutting edge is chipped along its length, and a small portion has broken away at one corner.

Reduction: A slight depression above the blade may have been inflicted at this stage, though no intrusive tool marks are to be found in association. This might suggest that it resulted from over-zealous hammering during manufacture, instead, and its presence might indicate that the metal was unusually thin here as a result of core misalignment. Some large, blunt depressions are visible in places on the upper body (illustrated) and these may result from damage inflicted by a trunion chisel.

21/02 (Acc. No. 93: 2-5: 12)

Description: Facetted socketed axe.

Dimensions: Length: 97mm. Cutting edge: 51mm. Weight: 179.2g.

Patina: Rough grey-green/olive, surface flaking in places. Details poor.

Manufacture: Traces of the casting seam survive around the mouth, but this may have been exaggerated by corrosion buildup. The upper casting seam is thick and prominent over much of the body. It remains sharp over the collar mouldings, though it has been flattened more extensively towards the cutting edge. The lower seam is similar, but has been flattened over the loop and is better finished over the collar. The cutting edge is crescentic in appearance.

Use: The cutting edge remains good. It appears blunt and chipped along its length, but corrosion buildup may have contributed to this.

Reduction: There are some possible small tool marks apparent halfway between the loop and the cutting edge on one face (illustrated). There are also some chisel marks occurring in the vicinity of the loop on the other face (not illustrated). Both sets of small tool marks may have been inflicted when the material which bound the axehead to the haft was removed.

21/03 (Acc. No. 93: 2-5: 7)

Description: Socketed axe of wing-decorated 'south-eastern' type.

Dimensions: Length: 105mm. Cutting edge: 41mm. Weight: 216.8g.

Patina: Rough grey-green, details poor.

Manufacture: The mouth appears uneven, indicating that an inadequate supply of metal was poured into the mould during casting. An additional notch in the mouth is evidence of another minor flaw, and there is some pitting in the surface on one face, which might indicate a poor quality casting. Over the body, the upper casting seam remains thick over the collar, though it appears to have been flattened, but it is obscured elsewhere following corrosion buildup. It may, however, have been obliterated over the lowermost third of the piece towards the cutting edge. The lower seam is prominent over the collar, and has been

removed completely over the loop. Elsewhere its condition is difficult to ascertain as a result of corrosion build-up. The blade seems narrow, but it has been expanded.

Use: The deep curvature of the blade probably indicates resharpener, and uneven wear prior to resharpener has left it asymmetrical. The cutting edge is now badly chipped along its length.

Reduction: There is a possible chisel mark in the collar, but the corrosion products obscure much detail here which makes interpretation difficult.

21/04 (Acc. No. 93: 2-5: 14)

Description: Incomplete socketed axe, of wing-decorated 'south-eastern' type. Internal ribs would have been present, though only one now survives.

Dimensions: Length: 86mm. Cutting edge: 42mm. Weight: 130.1g.

Patina: Rough grey-green, with copper-coloured lumps of encrustation obscuring much of one face. Details poor.

Manufacture: The broken wall shows uneven thickness in the section, indicating core misalignment, and a hole in the casting just below the level of the break undoubtedly represents a casting flaw. The mouth seems well-finished, but remains somewhat uneven. The upper seam shows as a faint trace over much of the body, but is obliterated over the last 40mm towards the cutting edge. The lower seam is similar, but has only been removed over the last c. 20mm towards the cutting edge. It has also been obliterated over the loop. The cutting edge has a crescentic appearance.

Use: The cutting edge seems very battered and worn over its length.

Reduction: There is no evidence which clearly indicates deliberate breakage. It is impossible to determine whether the piece cracked as a result of use-related stress or through deliberate fragmentation.

21/05 (Acc. No. 93: 2-5: 6)

Description: Socketed axe, of undecorated 'south-eastern' type.

Dimensions: Length: 96mm. Cutting edge: 49mm. Weight: 219.7g.

Patina: Dusty grey-green, details poor.

Manufacture: The mouth appears uneven, indicating that an inadequate supply of molten metal was provided during casting. The upper seam has been trimmed over the body, but it remains sharp to a point c. 15mm from the cutting edge. The lower seam is similar, though it seems slightly thicker and blunter over its length and is prominent between the collar and the loop. It has been obliterated over the loop, and some hammering is apparent in association with this. The cutting edge is crescentic in appearance.

Use: The cutting edge is blunt and chipped over its length, though this damage may be exaggerated by the build-up and subsequent flaking of the corrosion products.

Reduction: One possible chisel mark is visible on the body (illustrated), and this may have been inflicted during the separation of axehead and haft.

21/06 (Acc. No. 93: 2-5: 8)

Description: Socketed axe, of undecorated 'south-eastern' type.

Dimensions: Length: 97mm. Cutting edge: 37mm. Weight: 200.4g.

Patina: Rough grey-green, details poor.

Manufacture: The mouth appears rough, with vestigial traces of the feeders remaining though the intervening seam is virtually gone. Over the body, the top seam has been trimmed but it still remains visible and is quite sharp. Further down the piece, from halfway down the body to the cutting edge, it has been obliterated. Very little of the lower seam remains visible, as corrosion buildup obscures much detail here, though it is still faintly visible over the loop. The edge does not seem well-expanded.

Use: The cutting edge seems good, with just one chip apparent near one corner, but it appears rather blunt. Though this may be related to the nature of the corrosion product, the possibility that the piece remained unused at the time of deposition should not be discounted.

Reduction: The object is complete, and there is no evidence relating to this process.

21/07 (Acc. No. 93: 4-26: 9)

Description: Socketed axe, of undecorated 'south-eastern' type.

Dimensions: Length: 94mm (minus feeder). Cutting edge: 49mm. Weight: 228.6g.

Patina: Rough grey-green, details poor.

Manufacture: The mouth is uneven, probably as a result of an inadequate metal supply during casting, and two small rounded notches in the collar are additional casting flaws. Finishing here has been minimal, with the stumps of two feeders remaining prominent. The upper casting seam remains visible and is reasonably sharp over the length of the body, though it appears to have been trimmed. It survives all the way down to the cutting edge. The situation is similar on the underside, but here the seam has been flattened over the loop, though the loop still appears rather rough. The cutting edge has a crescentic appearance.

Use: The cutting edge is blunt but it appears to be intact. Its poor condition may result at least in part from corrosion build-up, however. One corner is slightly notched.

Reduction: Rough hammer indents can be identified on one face (not illustrated), at a point just below the loop. This seems more likely to be linked with scrapping than with manufacture. A chisel mark on one face may have been inflicted during the separation of axehead and haft.

21/08 (Acc. No. 93: 2-5: 10)

Description: Socketed axe, of undecorated 'south-eastern' type.

Dimensions: Length: 95mm. Cutting edge: 47mm. Weight: 214.2g.

Patina: Thick, dense grey-green, details good.

Manufacture: The mouth seems rather uneven, and some tiny rounded notches around its extent represent minor casting defects. Over the body, the upper casting seam has been trimmed and flattened in places, though it still remains quite sharp right down to the cutting edge. The lower seam is similar, but it has been flattened somewhat over the loop and the upper collar. Some vertical grinding marks are visible on the blade, and the cutting edge is well-expanded.

Use: A slight crack runs from one of casting defects at the mouth, and this may have been sustained through repeated use. The blade is chipped and blunt over its length, though its poor condition may be exaggerated by the nature of the corrosion product.

Reduction: There is a cluster of gouge and chisel marks on one face (illustrated), and these may have been inflicted when axehead and haft were separated.

21/09 (Acc. No. 93: 2-5: 13)

Description: Socketed axe, of undecorated 'south-eastern' type.

Dimensions: Length: 102mm. Cutting edge: 48mm. Weight: 206.9g.

Patina: Rough olive, with some darker and some lighter grey-green patches.

Manufacture: A serious casting defect is evident, with a substantial portion of the mouth absent. This has come about through a combination of an inadequate supply of metal during casting, and a failure of the liquid bronze to circulate properly within the mould. Despite this, the axehead appears to have been well finished. The casting seams have been trimmed along both sides of the body, though they remain quite sharp. The seam has, however, been flattened over the loop. The blade is widely expanded.

Use: The cutting edge is largely good, though it seems rather blunt, and is burred and notched in places along its length. Its condition could appear worse, however, as a result of corrosion buildup. There is no doubt that the object has been subject to use, though.

Reduction: Both faces have been crushed near what passes for a mouth. On one face (illustrated), significant distortion of the section has occurred, associated with cracking of the metal. Breakage has followed, resulting in the creation of a fragment which comprises part of one face and the underside, including the loop. This has been glued to its parent object in recent times. The other face has a minor depression near the top of the blade, but the damage is not so extreme here.

21/10 (Acc. No. 93: 2-5: 16)

Description: Socketed axe, of undecorated 'south-eastern' type. Two ribs are visible within the interior of the socket.

Dimensions: Length: 75mm. Cutting edge: 40mm. Weight: 139.1g.

Patina: Rough grey-green, details poor.

Manufacture: The mouth is uneven, with some isolated traces of the casting seam remaining visible in places. The uppermost seam remains prominent and sharp over the upper portion of the body, though it seems flatter towards the cutting edge. The lower seam is thick and prominent to a point c. 20mm back from the cutting edge. From this point to the cutting edge it has been well finished, and now only faint traces remain visible. Vestigial traces of the seam survive over the loop, though it has been flattened here. The cutting edge has been expanded.

Use: The cutting edge appears chipped and battered along its length.

Reduction: The object is complete, and there is no evidence relating to this process.

21/11 (Acc. No. 93: 2-5: 17)

Description: Socketed axe, of undecorated 'south-eastern' type.

Dimensions: Length: 74mm. Cutting edge: 40mm. Weight: 116.7g.

Patina: Thick pale green/olive, details poor.

Manufacture: The mouth is very rough and uneven, with traces of the seams apparent in places. Some dips in the mouth are casting defects, and the poor condition of the mouth indicates that an inadequate amount of metal was used during casting, and that the liquid bronze failed to circulate properly within the mould. In addition, the loop has a narrow, waisted appearance, and the surface of the bronze appears pitted in places, suggesting a poor quality casting. The upper seam remains thick and obtrusive over the entire length of the piece, though it seems more prominent over the collars and the upper body, and appears flatter towards the cutting edge. The lower seam is very prominent over the collars, where trimming appears to have been minimal. It is still visible over the loop, and remains evident over the rest of the piece, too, though no traces survive in the immediate vicinity of the cutting edge. The blade is crescentic in appearance, and some coarse grinding marks on one face (illustrated) may be linked with resharpening or initial manufacture.

Use: The edge is burred and chipped over much of its length, but this damage may have been exaggerated by corrosion buildup.

Reduction: Some small chisel marks are apparent on the upper body, and another is present on the collar. These marks may have been inflicted when axehead and haft were separated.

21/12 (Acc. No. 93: 2-5: 15)

Description: Mouth and upper body of 'southern English' type socketed axe, with three ribs on either face.

Dimensions: Length (maximum): 75mm. Weight: 218.0g.

Patina: Rough grey-green, details poor.

Manufacture: At the break, the walls show uneven thickness, indicating core misalignment. Vestigial traces of the seam remain visible around the mouth. Over the body, the upper seam survives in vestigial form to a point c. 20mm back from the break, and though it has been trimmed it remains quite sharp. The lower seam is prominent over much of its length, though only faint traces remain over the final 20mm towards the cutting edge, and it has been flattened and smoothed over the loop.

Use: Impossible to determine.

Reduction: Both faces have faint depressions visible in the vicinity of the decoration. These appear to have been caused by hammering, perhaps inflicted during the removal of the axehead from its haft. No evidence can be clearly associated with fragmentation.

21/13 (Acc. No. 93: 4-26: 2-5: 18)

Description: Mouth and upper body of wing-decorated 'south-eastern' socketed axe.

Dimensions: Length (maximum): 55mm. Weight: 146.2g.

Patina: Rough grey-green, details poor.

Manufacture: At the break, the walls are uneven in thickness, indicating core misalignment. Some vestigial traces of the seam remain in places around the mouth, but the piece is basically well finished here. The upper seam only survives over the collar mouldings, having been obliterated elsewhere. Vestigial traces run down the entire length of the underside, however.

Use: Impossible to determine.

Reduction: The piece has been crushed following hammering down the centre of the face on both sides. The resulting distortion is particularly severe in the vicinity of the mouth on one face (illustrated), and cracking of the metal is apparent here.

21/14 (Acc. No. 93: 2-5: 20)

Description: Incomplete mouth and upper body of undecorated 'south-eastern' type socketed axe.

Dimensions: Length (maximum): 61mm. Weight: 75.0g.

Patina: Thick olive, with some mid-green patches, details poor.

Manufacture: The mouth seems smooth and is reasonably well-finished. The condition of the upper seam cannot be determined, but the lower seam has been removed over the loop and has been obliterated between the loop and the break, though faint traces are still visible immediately next to the break. While the wall section of both faces is of uniform thickness, the wall of the lower surface seems unusually thick in section. It may therefore be inferred that the wall at the upper surface was too thin as a result of core misalignment.

Use: An unusually thin wall to the upper surface might have resulted in breakage during use, but no evidence can be found which can confidently support this hypothesis.

Reduction: The fragment has been crushed down the length of either face. This has caused distortion of the section, though no individual hammer indents can be identified. In the vicinity of the mouth, cracking of the metal has occurred, and another crack, occurring halfway down one face has caused part of the collar to break away from the main portion of the piece. There is a further crack following the line of the collar moulding on the interior of the face illustrated. It is possible that the breakage pattern exploited weaknesses already inherent in the piece, i.e. use-related cracking and/or breakage. However, it seems likely that blows were deliberately concentrated along the centre of the face in order to break an upper body fragment into two roughly equal pieces.

21/15 (Acc. No. 2-5: 19)

Description: Lower body and cutting edge of 'south-eastern' type socketed axe, with vestigial traces of wing-decoration present.

Dimensions: Length (maximum): 77mm. Cutting edge: 45mm. Weight: 136.2g.

Patina: Thick olive, with some pale green patches. Details reasonable.

Manufacture: The seams have been virtually obliterated over both sides of the body, with only very faint traces remaining.

Use: The cutting edge is chipped over its length. Some of this damage is recent, linked with flaking of the corrosion product, but some certainly took place in antiquity.

Reduction: The object has been hammered on both faces. This has caused slight distortion of the section, forming a depression which runs the length of the lower body on both faces. Many individual hammer indents are visible in association with this damage.

21/16 (Acc. No. 93: 2-5: 14)

Description: Lower body and cutting edge of socketed axe.

Dimensions: Length (maximum): 70mm. Cutting edge: 55mm. Weight: 142.5g.

Patina: Rough greenish brown with black and grey patches. Details reasonable.

Manufacture: The wall is of uneven thickness, indicating core misalignment. Vestigial traces of the casting seams are visible over both sides. They appear to have been trimmed and ground, without having been flattened. The cutting edge has a crescentic appearance.

Use: The blade is badly battered with much of its original edge now missing, though this damage is not so evident on the side illustrated.

Reduction: Hammering has caused distortion of the section in the vicinity of the break on both faces. Some long notches are apparent on one face at the break (illustrated) and they are of unusual form. They seem too irregular to be associated with any known tool type, though they might have been caused by a number of superimposed trunnion chisel marks. Alternatively, they may reflect changes in the structure of the metal caused by the stresses imposed during fragmentation.

21/17 (Acc. No. 93: 2-5: 23)

Description: Lower body and cutting edge of faceted type socketed axe. The interfaces between the faces and their adjoining surfaces are defined by ribs.

Dimensions: Length (maximum): 63mm. Cutting edge: 51mm. Weight: 97.5g.

Patina: Thick grey-olive, details reasonable.

Manufacture: The casting seams are virtually invisible over both sides, with only faint fissures marking their original line. The cutting edge is well-expanded.

Use: The cutting edge seems fine but is blunt over its length. Its condition may result in part from corrosion buildup, however.

Reduction: Hammering has caused distortion of the section and has left marked depressions in both faces. Some individual hammer indents can be isolated on one face (illustrated). Cracking of the metal has occurred near one of the ribs (not illustrated) as a result of this damage.

21/18 (Acc. No. 93: 2-5: 22)

Description: Cutting edge of socketed axe. The blade has a solid section throughout much of its length.

Dimensions: Length (maximum): 45mm. Cutting edge: 35mm. Weight: 63.7g.

Patina: Dense brownish-olive. Details reasonable, but any traces of fine working have been obscured.

Manufacture: The rounded appearance to the notch which is apparent at one corner of the blade (on the left-hand side in the illustration) may be due, at least in part, to a casting defect, and the walls are of uneven thickness, indicating core misalignment. The casting seams have been obliterated on either side of the body.

Use: The two large breaks at either corner may be use-related. The edge, where it remains intact, is distorted and badly burred along its length.

Reduction: The damage noted above may have been deliberately inflicted at this phase of the object's life-cycle, i.e. by striking the edge repeatedly with a blunt hard object.

21/19 (Acc. No. 93: 2-5: 24)

Description: Cutting edge of socketed axe, ribs visible on the interior.

Dimensions: Length (maximum): 47mm. Cutting edge: 45mm. Weight: 86.9g.

Patina: Rough grey-green and blackish-grey, details poor.

Manufacture: The walls are uneven in thickness at the break, indicating core misalignment. Over both sides of the body, the casting seams have been virtually obliterated, and the blade has been well-expanded.

Use: The edge is battered and chipped along its length, and is notched in a number of places. This damage may have been exaggerated by corrosion buildup and subsequent flaking.

Reduction: A slight depression is evident at the break where the wall is thinner, and there are some possible hammer indents visible in association with this (not illustrated).

21/20 (Acc. No. 93: 2-5: 21)

Description: Short mouth fragment of a ?wing-decorated 'south-eastern' type socketed axe.

Dimensions: Length (maximum): 36mm. Weight: 47.7g.

Patina: Rough grey-green, details poor.

Manufacture: The mouth, where it survives, is rough and uneven in appearance. Vestigial traces of the casting seams remain visible around the mouth and over the body, though all traces have been obliterated over the loop.

Use: Impossible to determine.

Reduction: The face, where it remains intact, appears to have been pushed outwards. It is impossible to establish whether this was the result of use-related breakage or deliberate damage. Some notches on the mouth and the loop appear to be chisel marks, but it is possible that they represent casting flaws.

21/21 (Acc. No. 93: 2-5: 25)

Description: Socketed gouge, with no collar mouldings present.

Dimensions: Length: 81mm. Blade width: 16mm. Weight: 52.6g.

Patina: Dense olive and grey-green. Details good.

Manufacture: The object is well finished, with only faint traces of the casting seams surviving on either side. Vertical grinding marks run down the interior of the blade, and

some horizontal grinding marks can also be seen in the vicinity of the seam at one side. The bronze appears pitted in places, which seems to indicate a poor quality casting.

Use: The blade appears fine and unblemished. It is chipped in places, but this damage seems to have been caused by later loss of the corrosion product.

Reduction: A depression located directly above the blade of the gouge may have been caused by a hammer blow, but no obvious hammer indent can be seen here. Such damage may have been inflicted during an attempt to loosen a tightly wedged haft, as no attempts to crush the section appear to have been made.

21/22 (Acc. No. 93: 2-5: 26)

Description: Socketed gouge, with no collar moulding present.

Dimensions: Length: 61mm. Blade: 13mm. Weight: 34.3g.

Patina: Thick grey-green, details reasonable.

Manufacture: The casting seam has been removed around the mouth, but over the sides both seams remain prominent right down to the blade edge, though they appear to have been flattened here and have possibly been ground.

Use: The blade seems a little uneven and is chipped in a few places.

Reduction: The mouth shows cracking and distortion of the section, and hammering is apparent in association with this damage. A group of small tool marks on the back of the piece (fig. 9) appear to have been inflicted by a chisel.

Fig. 9



21/23 (Acc. No. 93: 2-5: 2)

Description: Shoulder and upper blade of 'Ewart Park' type sword. Four rivet holes remain complete, and a further two incomplete examples are visible at the upper break.

Dimensions: Length (maximum): 98mm. Weight: 156.4g.

Patina: Rough grey-green/olive/black. Details poor.

Manufacture: No traces of any casting seams survive, and the surface of the piece seems to have been subject to fine hammer working. Faint bevels run down the length of both cutting edges.

Use: The cutting edges seem blunt, and are chipped over their length, though this damage may have been exaggerated by the build-up and subsequent flaking of corrosion products. The two uppermost complete rivet holes appear elongated and strained, and the break at the tang may have resulted from use-related breakage of the metal at its weakest point. There are some depressions in this area which might suggest deliberate breakage, but these cannot be clearly identified as hammer indents.

Reduction: No evidence can be clearly linked with this process. The profile seems straight, with no obvious indications of hammering apparent.

21/24 (Acc. No. 93: 2-5: 5)

Description: Blade fragment of 'Ewart Park' type sword.

Dimensions: Length (maximum): 115mm. Weight: 138.1g.

Patina: Rough grey-green, details poor.

Manufacture: The surface appears pitted in places, which might suggest a poor quality casting. There is no other evidence relating to this process.

Use: The cutting edges are missing over much of their original extent, and where they remain intact they are chipped and notched over their length.

Reduction: There is a faint bend to the profile, though no hammer indents are to be found in association with either break. The edges show large burred notches in places, and it is possible that this damage was deliberately inflicted, perhaps by striking the blade with a heavy blunt object, such as a hammer.

21/25 (Acc. No. 93: 2-5: 4)

Description: Blade fragment of 'Ewart Park' sword.

Dimensions: Length (maximum): 80mm. Weight: 78.4g.

Patina: Rough grey, details poor.

Manufacture: The surface is pitted in places, suggesting a poor finish or even a poor quality casting. Fine hammering is evident, however, especially along the cutting edges.

Use: The cutting edges are badly notched and chipped over their length, though where they remain undamaged they remain fine and sharp. Small holes are evident in the cross-section at the upper break, and this - like the pitting described in 'Manufacture' above, might suggest a weakness in the casting. However, this weakness was not the cause of breakage itself (see below), though the casting may have been predisposed to cracking in this location.

Reduction: Hammer indents can be identified on either side at the upper break, though no similar evidence is visible in association with the lower one. Some tiny chisel marks are visible on one face, and a faint bend is visible in the profile.

21/26 (Acc. No. 93: 2-5: ?3)

Description: Blade fragment from near the tip of a leaf-shaped sword.

Dimensions: Length (maximum): 53mm.

Patina: Rough grey-green, details poor.

Manufacture: A faint bevel can be seen on the edges, and possible grinding marks run vertically down both faces.

Use: The edges seem very blunt and a little rough, though their condition may appear worse as a result of the build-up of corrosion products.

Reduction: A hammer indent is visible at the top break (not illustrated), and another is visible on the lower break of the other face (illustrated).

21/27 (Acc. No. 93: 2-5: 1)

Description: Fragment of 'Carp's Tongue' sword blade. The midrib is defined by grooves, and additional decoration is present in the form of a series of impressed diagonal lines which run down both bevels on either side of the blade. Under magnification, these proved to be crescentic in shape. It seems likely that they represent fingernail marks impressed upon the original wax former around which the clay mould was made.

Dimensions: Length (maximum): 40mm. Weight: 62.3g.

Patina: Rough grey/green/brown, details reasonable.

Manufacture: No evidence can be linked with this process.

Use: The cutting edge remains reasonable on one side, while on the other it is extremely battered.

Reduction: Hammer indents are visible on either face at the uppermost break, and on one face (not illustrated) at the lower break.

21/28 (Acc. No. 93: 2-5: 52)

Description: Fragment of pouch-shaped object, described by Burgess and Colquhoun as 'sheet metal'. The piece must have been some form of decorative fitting, but it is difficult to properly ascribe any functional purpose to it, though it could conceivably be a larger variant of a purse chape.

Dimensions: Length (maximum): 43mm. Weight: 51.8g.

Patina: The object is coppery in colour, with a fissured surface, and some patches of light-green apparent. The corrosion has been stripped and, consequently, all surface detail has been lost.

Manufacture: No traces of the casting seam can be seen around the piece.

Use: Impossible to determine.

Reduction: The piece is distorted, its entire surface undulating across one face. This same surface is very rough in appearance, and has probably been subject to rough hammering. Crushing has occurred as a result of this hammering, and a small cylindrical object, probably a large rivet originally used to fix the piece to its host object, is now trapped within the piece, along with a small piece of bronze which may be a tiny body fragment from a socketed axe.

21/29 (Acc. No. 93: 2-5: 27)

Description: Fragment from the valve of a mould for socketed axe, probably of 'south-eastern' type (c.f. Grays Thurrock I, 02/224). The exterior of the mould is decorated, bearing vertical ribs and a single raised knob on its surviving extent. It seems likely that an

axe similar in dimensions to 21/06 would have been produced using this mould.

Dimensions: Length (maximum): 34mm. Weight: 69.1g.

21/30 (Acc. No. 93: 2-5: 28)

Description: Casting jet, with two feeders present. Its dimensions suggest that it would have been produced during the casting of a socketed axe.

Dimensions: Length (maximum): 43mm. Weight: 69.4g.

21/31 (Acc. No. 93: 2-5: 29)

Description: Large piece from edge of copper ingot.

Dimensions: Length: 75mm. Width: 83mm. Thickness: 28mm. Weight: 557.4g.

21/32 (Acc. No. 93: 2-5: 31)

Description: Piece from edge of copper ingot.

Dimensions: Length: 52mm. Width: 50mm. Thickness: 20mm. Weight: 326.1g.

21/33 (Acc. No. 93: 2-5: ?51)

Description: Fragment from edge of copper ingot, numerous voids apparent in the interior.

Dimensions: Length: 36mm. Width: 31mm. Thickness: 15mm. Weight: 58.5g.

21/34 (Acc. No. 93: 2-5: 32)

Description: Large piece from edge of copper ingot, with numerous voids apparent in the interior.

Dimensions: Length: 79mm. Width: 61mm. Thickness: 23mm. Weight: 323.2g.

21/35 (Acc. No. 93: 2-5: 33)

Description: Large piece from edge of copper ingot, with numerous voids apparent in the interior.

Dimensions: Length: 84mm. Width: 62mm. Thickness: 24mm. Weight: 318.6g.

21//36 (Acc. No. 93: 2-5: 34)

Description: Piece from edge of copper ingot, with voids present in the interior.

Dimensions: Length: 53mm. Width: 60mm. Thickness: 21mm. Weight: 245.6g.

21/37 (Acc. No. 93: 2-5: 35)

Description: Piece from edge of copper ingot, very thick in section.

Dimensions: Length: 60mm. Width: 57mm. Thickness: 28mm. Weight: 296.4g.

21/38 (Acc. No. 93: 2-5: 30)

Description: Large piece from edge of copper ingot, very thick in section.

Dimensions: Length: 75mm. Width: 75mm. Thickness: 33mm. Weight: 582.8g.

21/39 (Acc. No. 93: 2-5: ?)

Description: Piece from edge of copper ingot.

Dimensions: Length: 63mm. Width: 61mm. Thickness: 23mm. Weight: 416.4g.

21/40 (Acc. No. 93: 2-5:46)

Description: Fragment from edge of copper ingot.

Dimensions: Length: 41mm. Width: 28mm. Thickness: 24mm. Weight: 125.1g.

21/41 (Acc. No. 93: 2-5: 38)

Description: Piece from edge of copper ingot.

Dimensions: Length: 60mm. Width: 52mm. Thickness: 17mm. Weight: 327.0g.

21/42 (Acc. No. 93: 2-5: 39)

Description: Piece from edge of copper ingot, with numerous voids apparent in the interior.

Dimensions: Length: 49mm. Width: 55mm. Thickness: 21mm. Weight: 145.9g.

21/43 (Acc. No. 93: 2-5: 40)

Description: Small piece from edge of copper ingot, with numerous voids apparent in the interior.

Dimensions: Length: 58mm. Width: 40mm. Thickness: 20mm. Weight: 170.2g.

21/44 (Acc. No. 93: 2-5: 41)

Description: Fragment from interior of copper ingot.

Dimensions: Length: 43mm. Width: 32mm. Thickness: 20mm. Weight: 145.1g.

21/45 (Acc. No. 93: 2-5: 42)

Description: Fragment from interior of copper ingot, with numerous voids apparent in the section.

Dimensions: Length: 42mm. Width: 31mm. Thickness: 20mm. Weight: 155.1g.

21/46 (Acc. No. 93: 2-5: 43)

Description: Fragment from interior of copper ingot.

Dimensions: Length: 44mm. Width: 30mm. Thickness: 18mm. Weight: 109.6g.

21/47 (Acc. No. 93: 2-5: 44)

Description: Fragment from edge of copper ingot, with numerous voids apparent within the section.

Dimensions: Length: 32mm. Width: 35mm. Thickness: 20mm. Weight: 111.1g.

21/48 (Acc. No. 93: 2-5: 45)

Description: Small piece from interior of copper ingot.

Dimensions: Length: 46mm. Width: 33mm. Thickness: 12mm. Weight: 107.6g.

21/49 (Acc. No. 93: 2-5: 47)

Description: Fragment from interior of copper ingot.

Dimensions: Length: 35mm. Width: 25mm. Weight: 91.9g.

21/50 (Acc. No. 93: 2-5: 48)

Description: Fragment from interior of copper ingot.

Dimensions: Length: 35mm. Width: 33mm. Thickness: 20mm. Weight: 94.0g.

Observations: There is some cracking of the metal apparent on one surface (illustrated), and this damage may be linked with fragmentation of the ingot.

21/51 (Acc. No. 93: 2-5: 49)

Description: Fragment from edge of copper ingot.

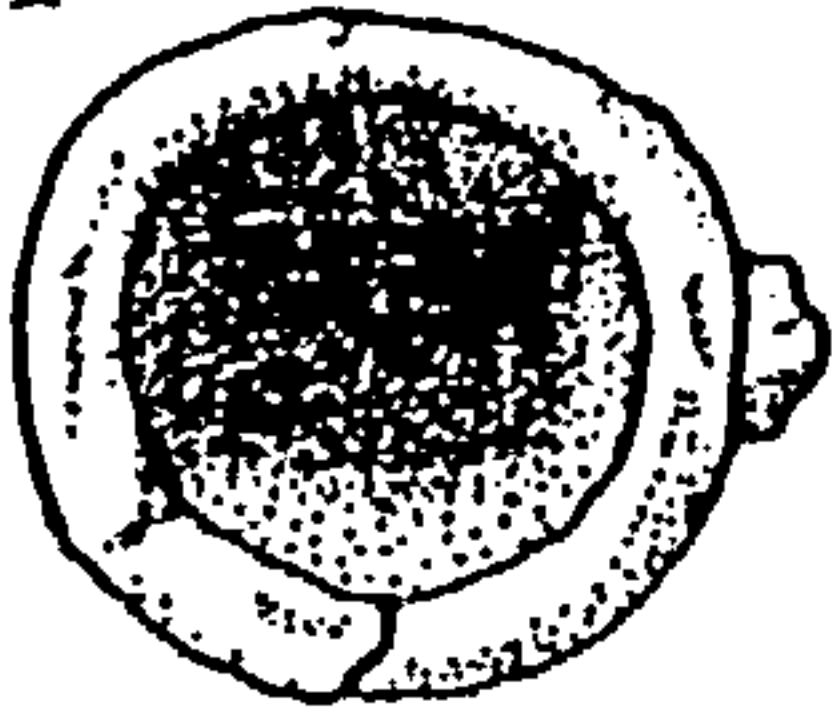
Dimensions: Length: 39mm. Width: 34mm. Thickness: 20mm. Weight: 85.2g.

21/52 (Acc. No. 93: 2-5: 50)

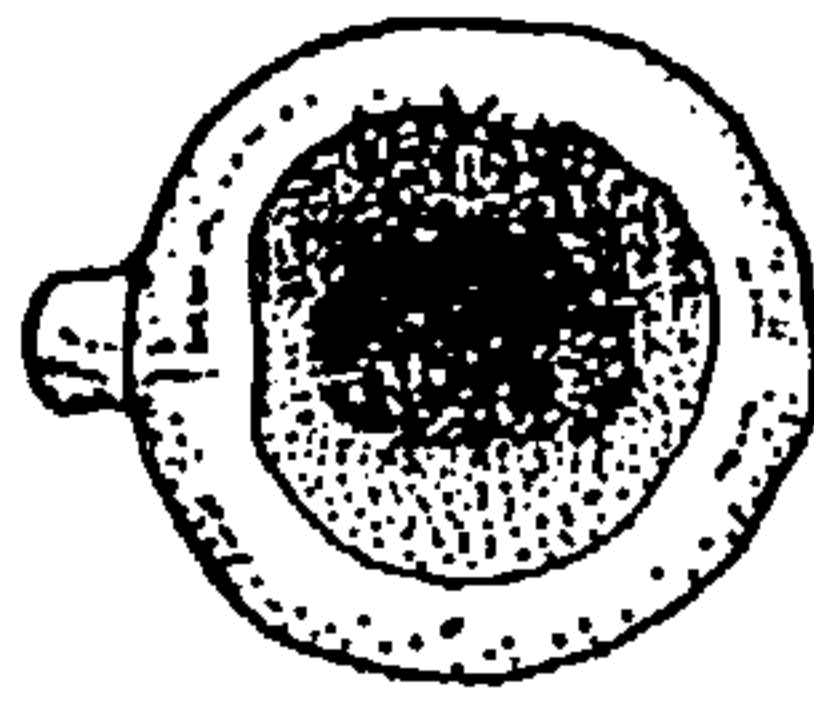
Description: Fragment from edge of copper ingot, with a large number of voids apparent in the interior.

Dimensions: Length: 45mm. Width: 32mm. Thickness: 15mm. Weight: 74.0g.

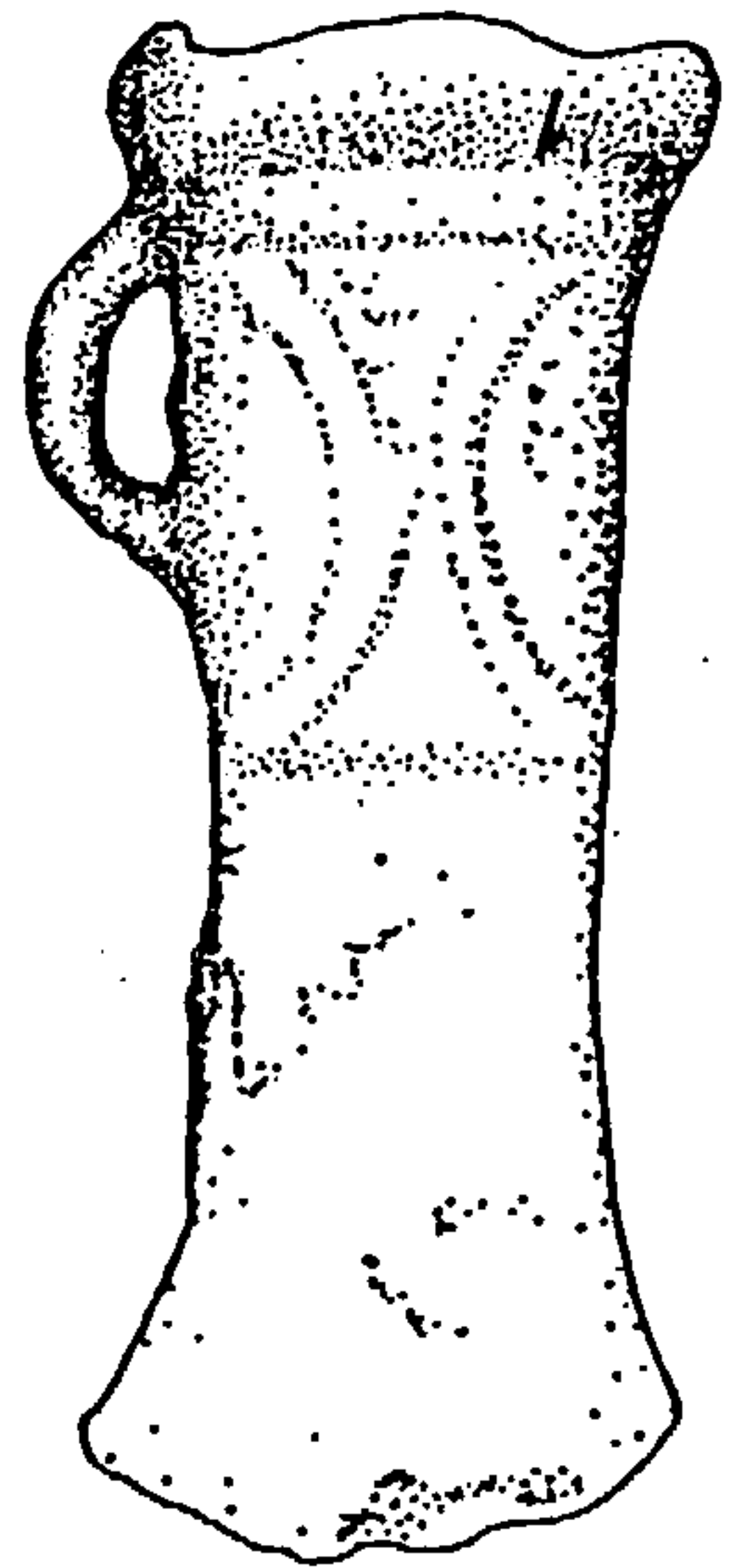
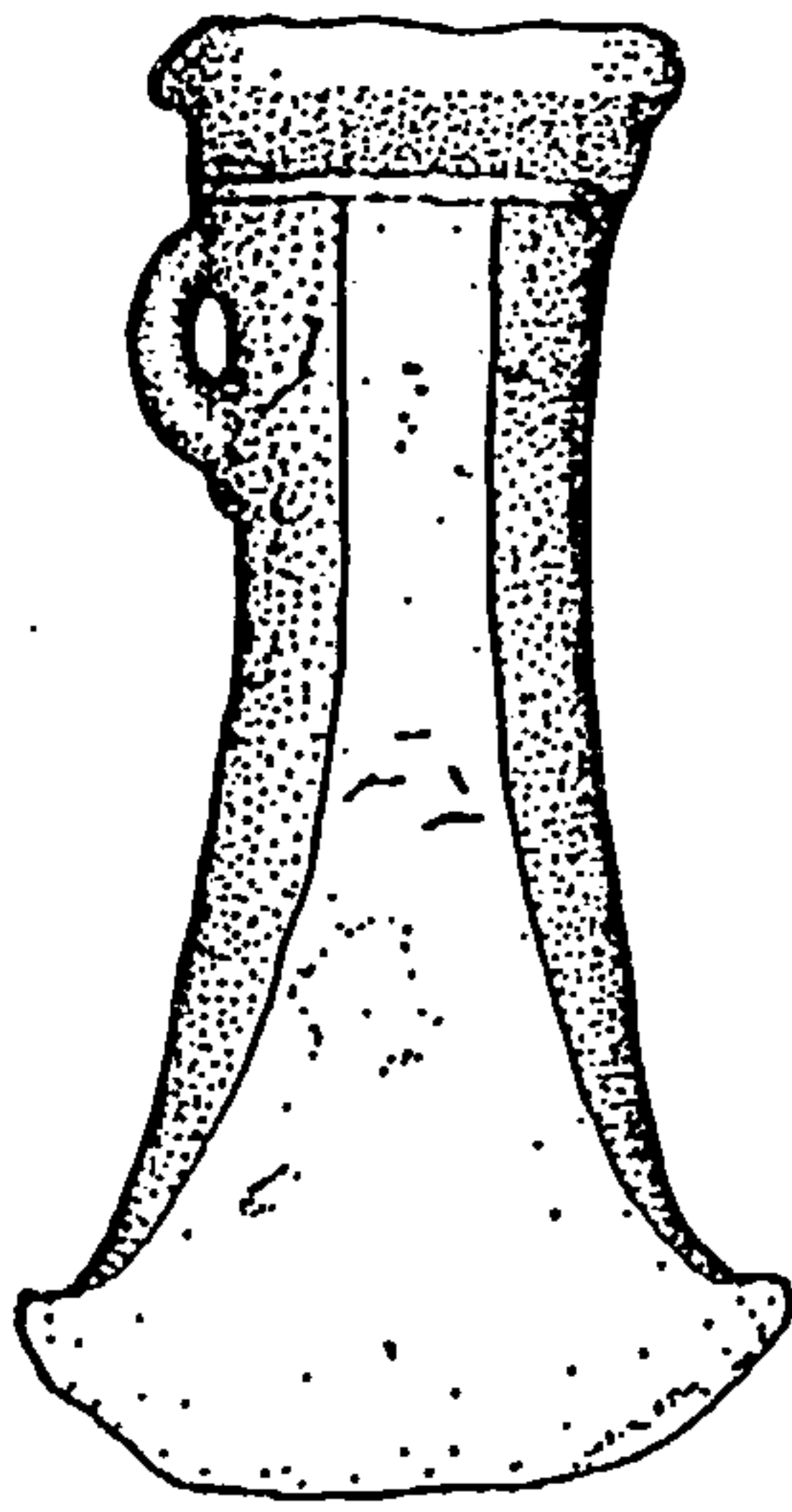
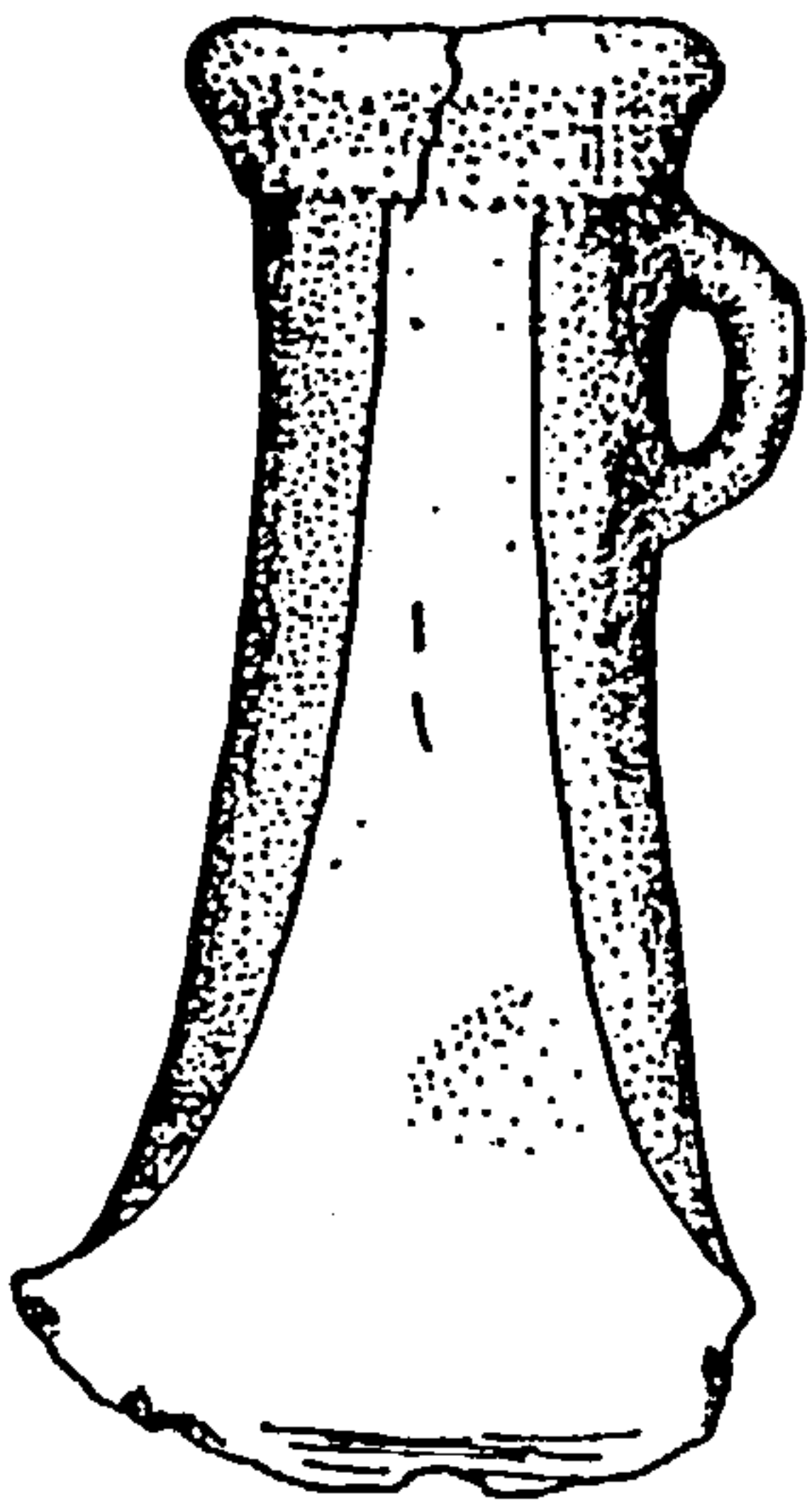
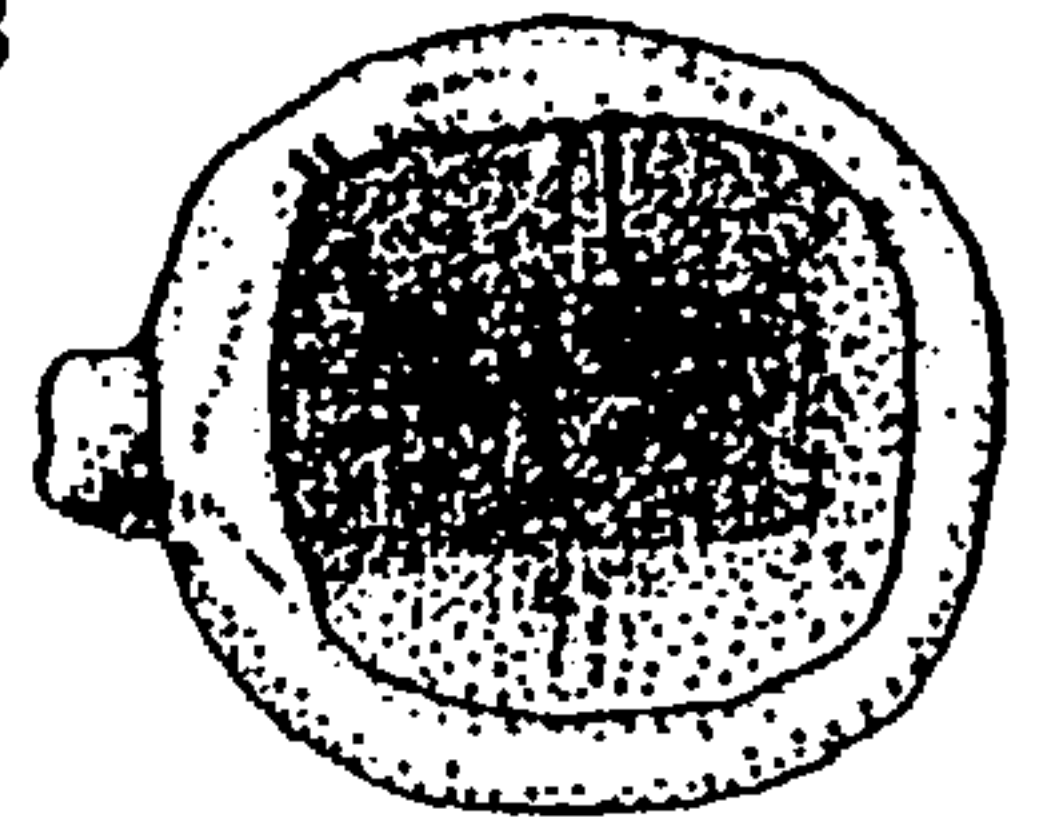
21/01



21/02

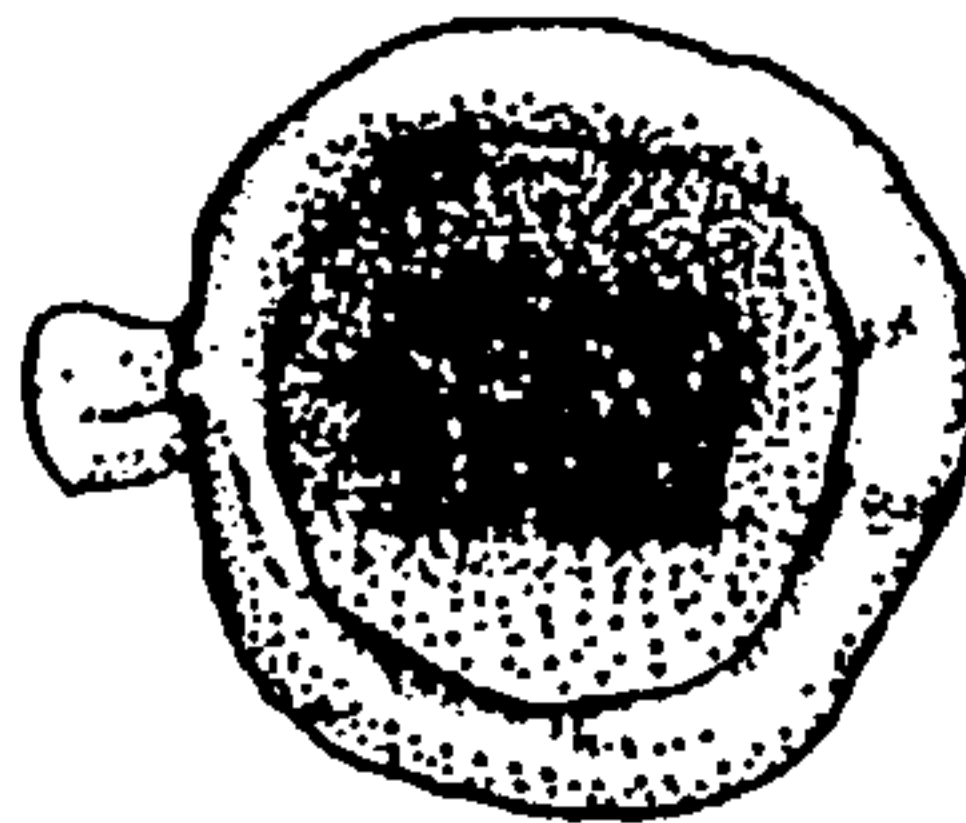


21/03

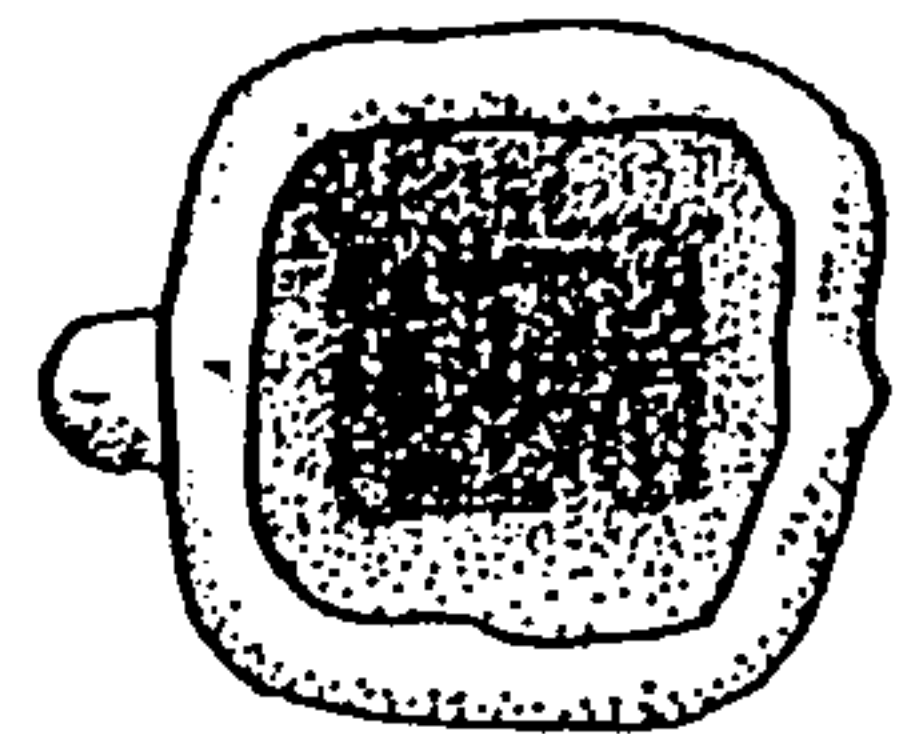


0 2cm

21/05



21/06



21/04

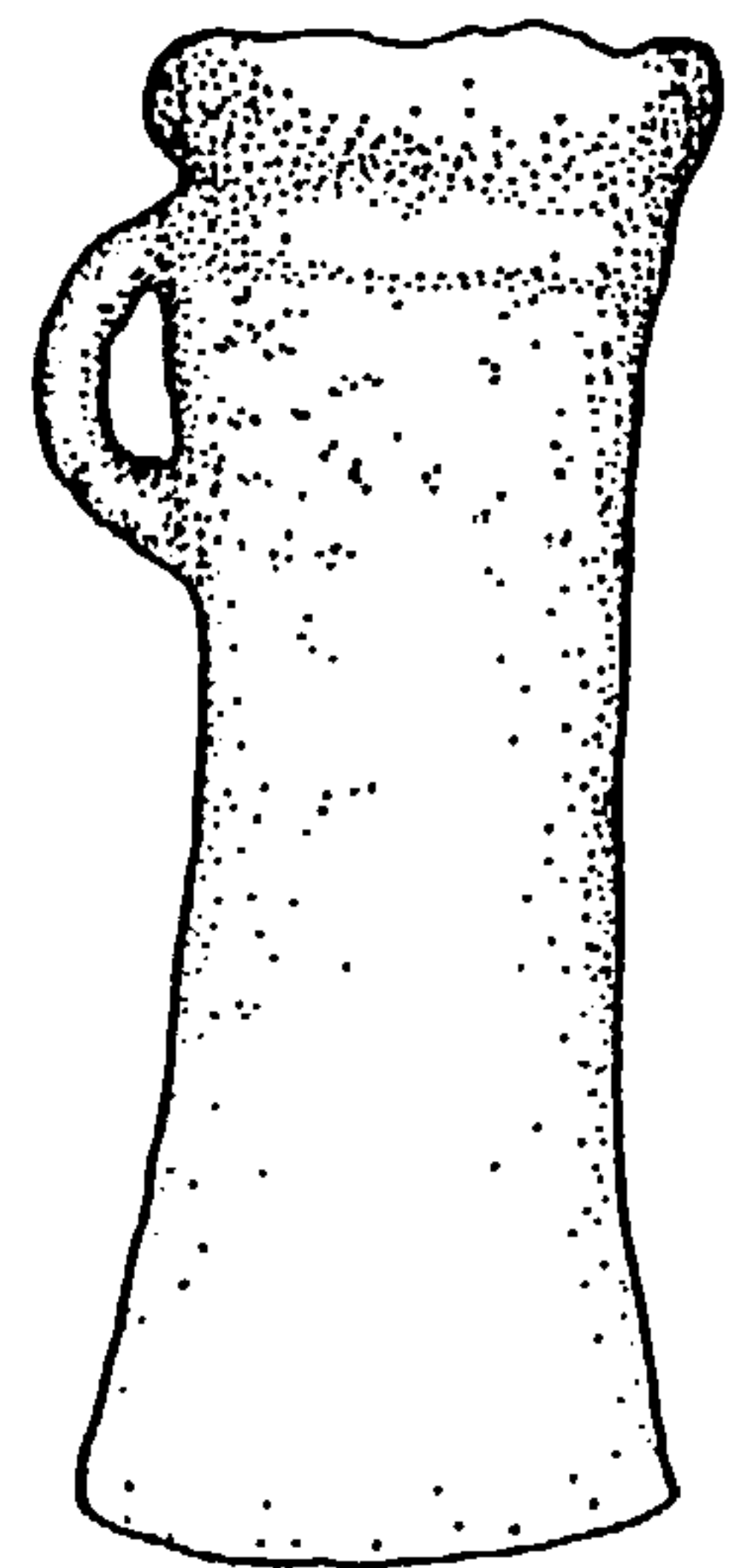
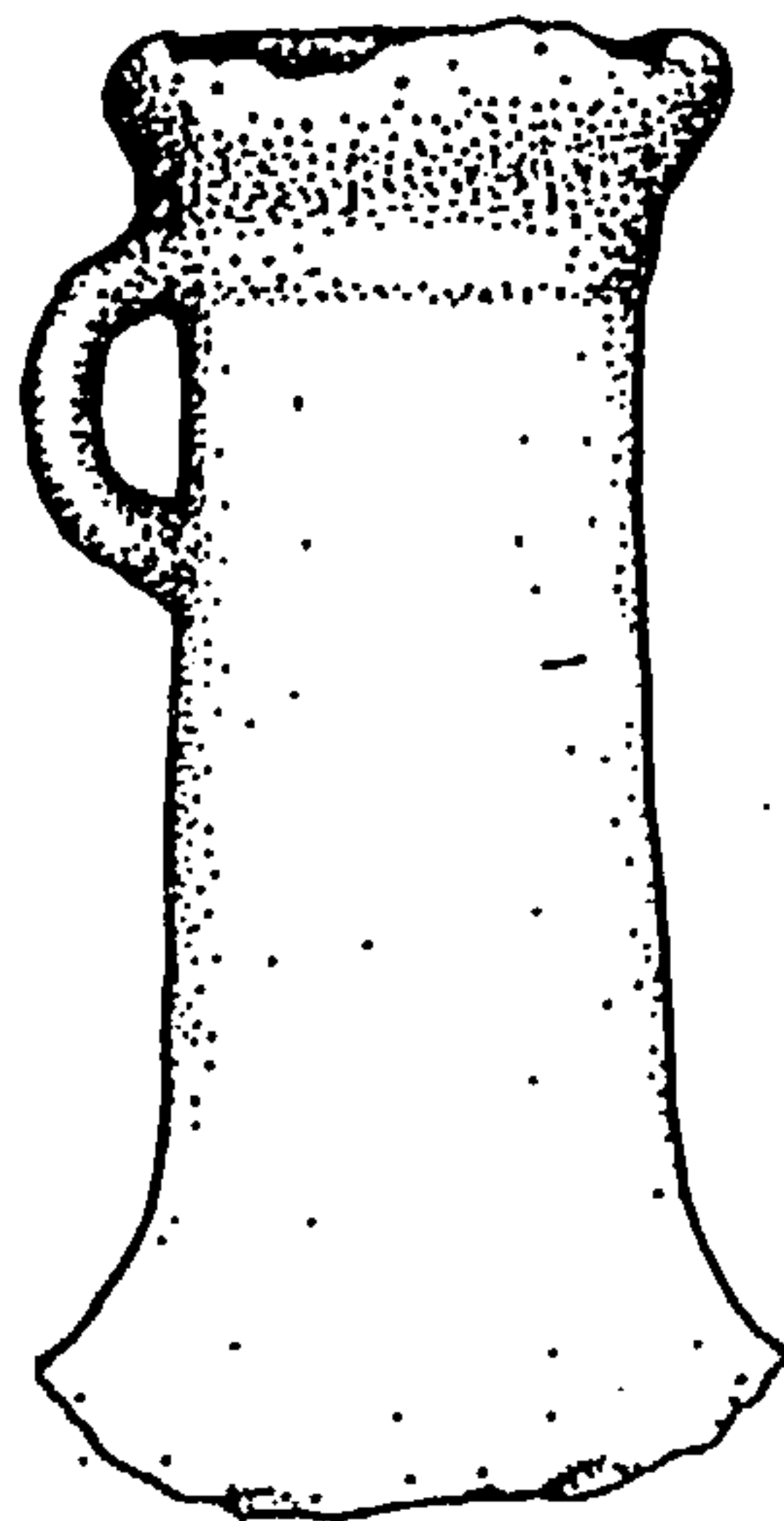
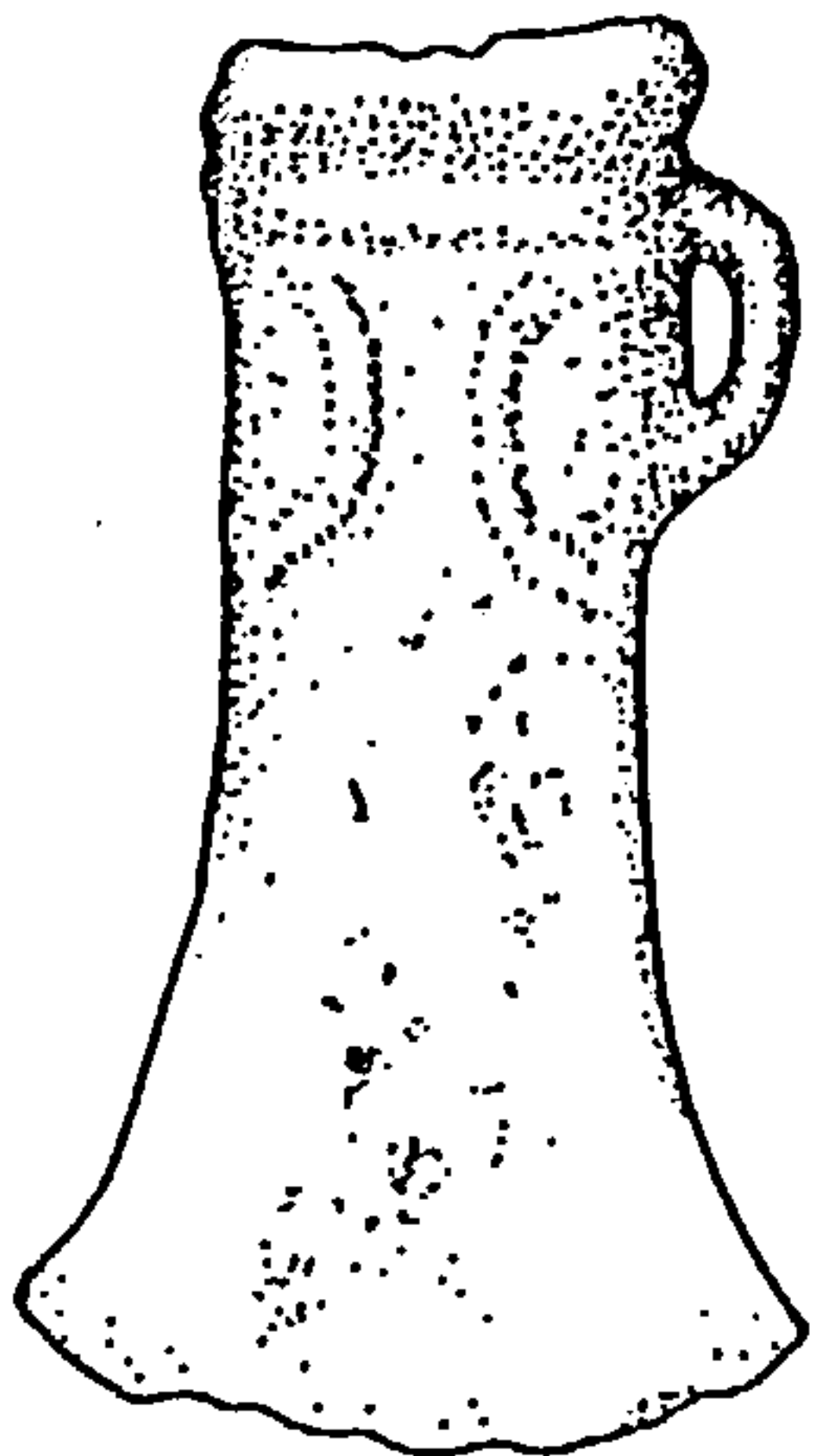
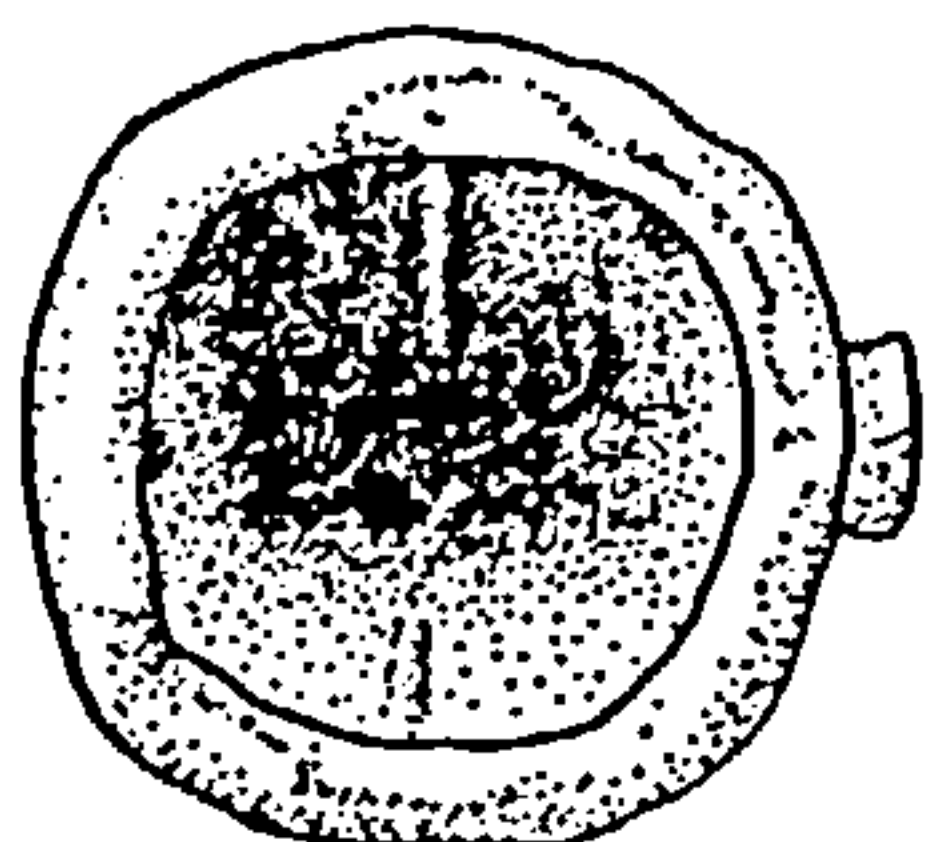
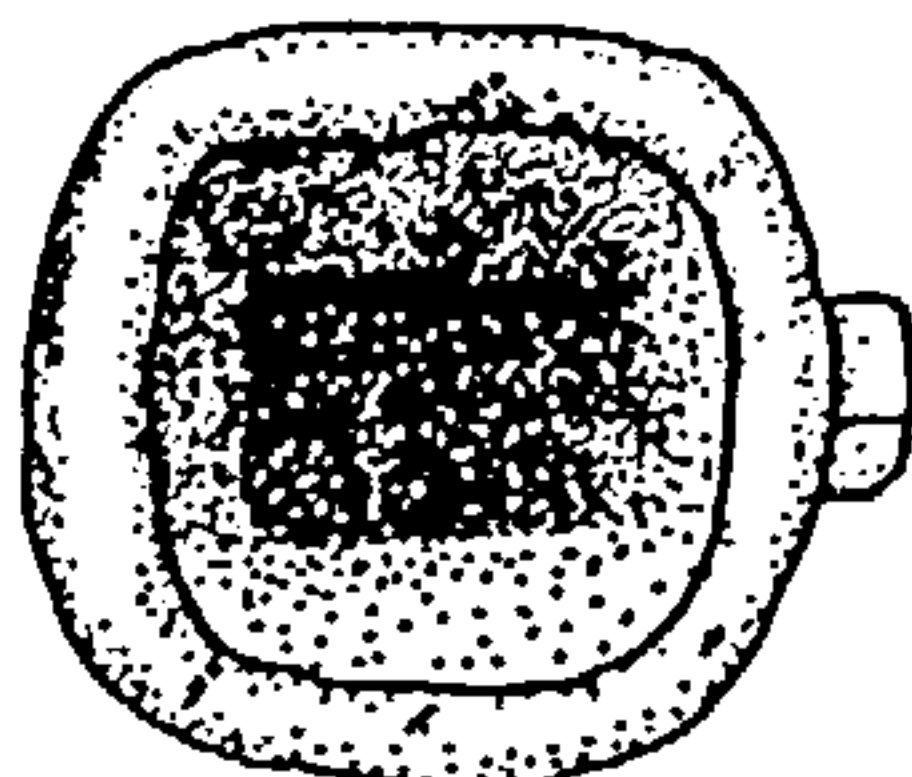


Fig. 78: The Stoke-at-Hoo Hoard (Ref. No. 21): Socketed Axes (i)

21/07

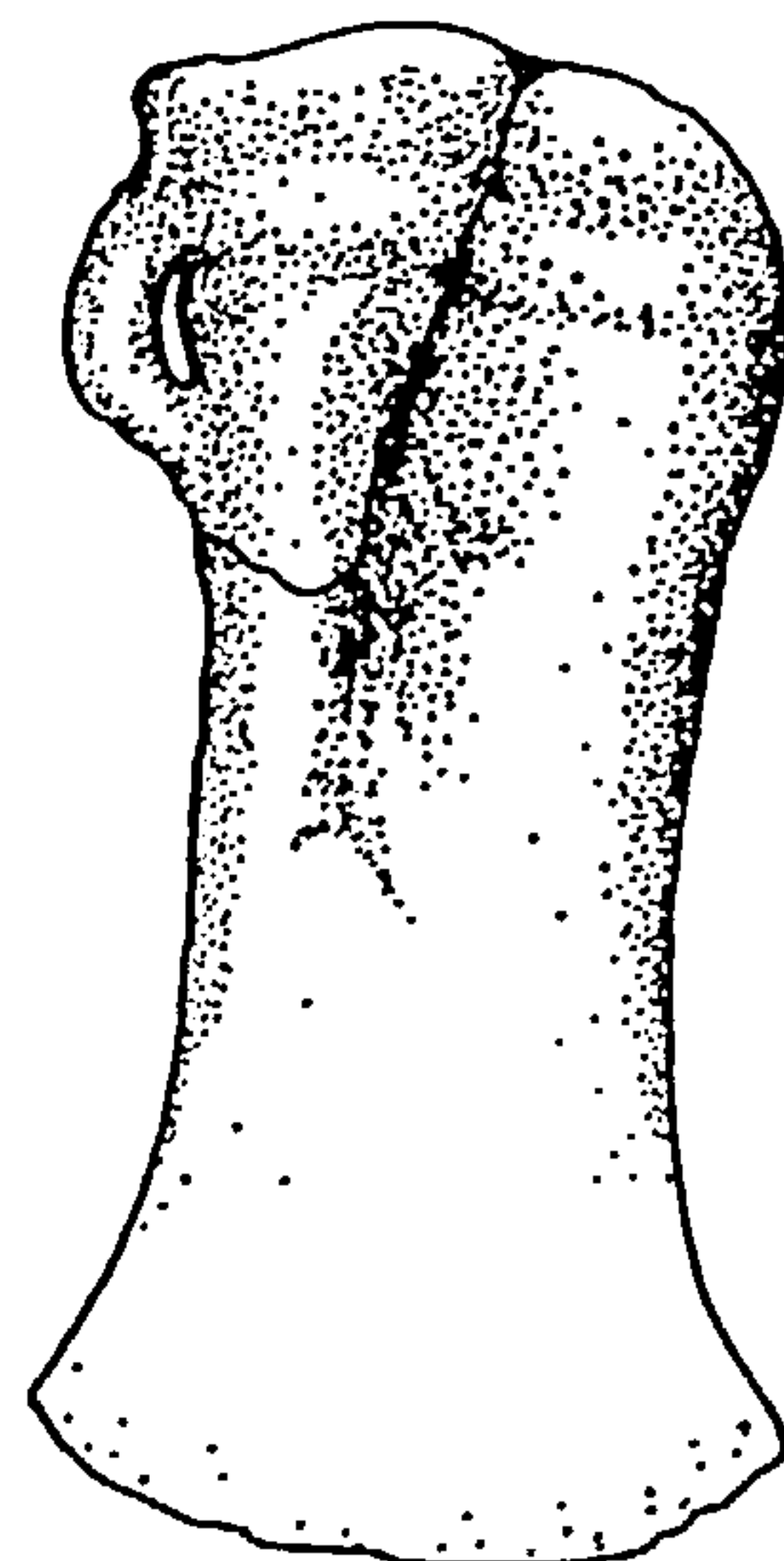
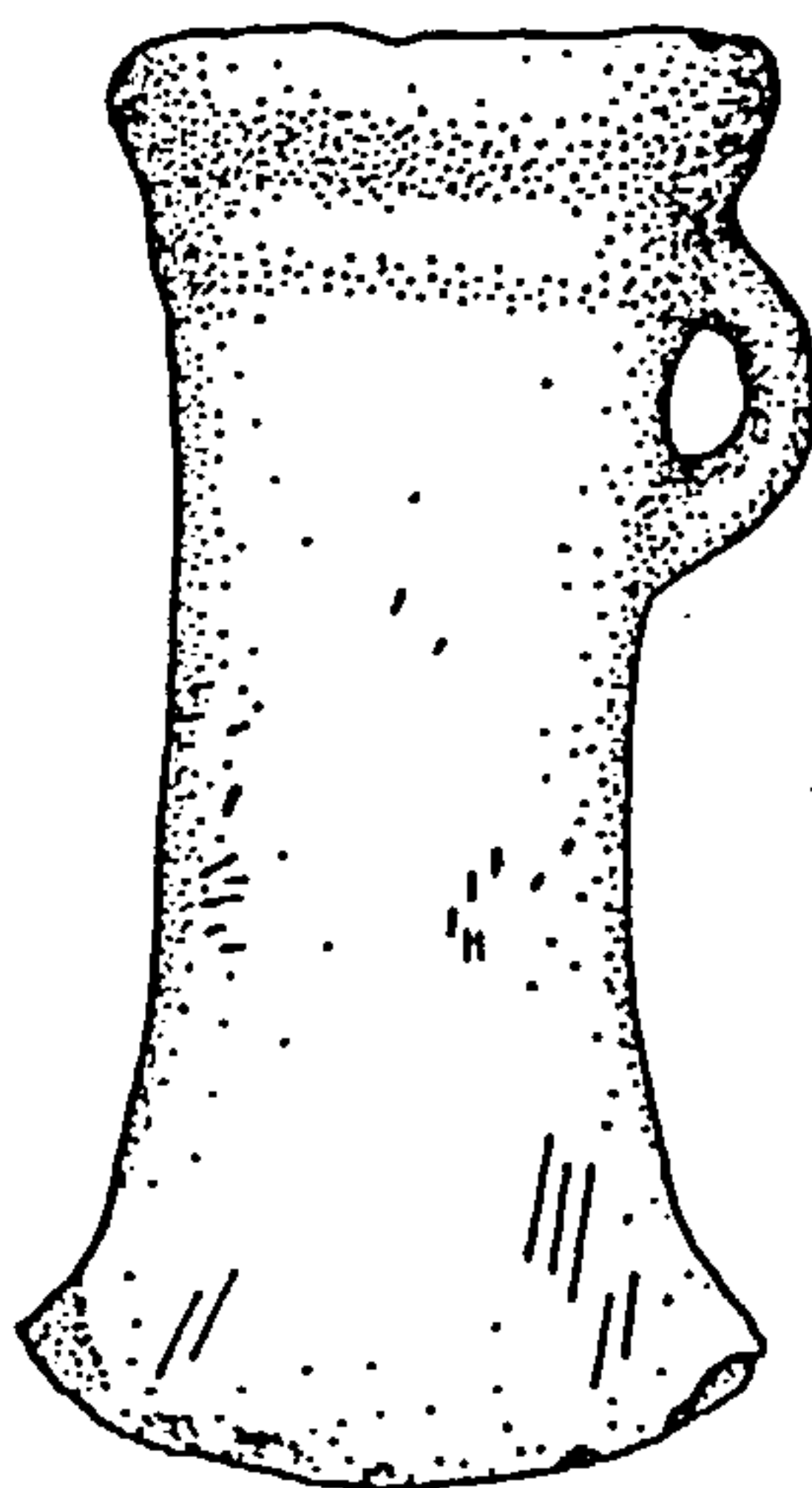
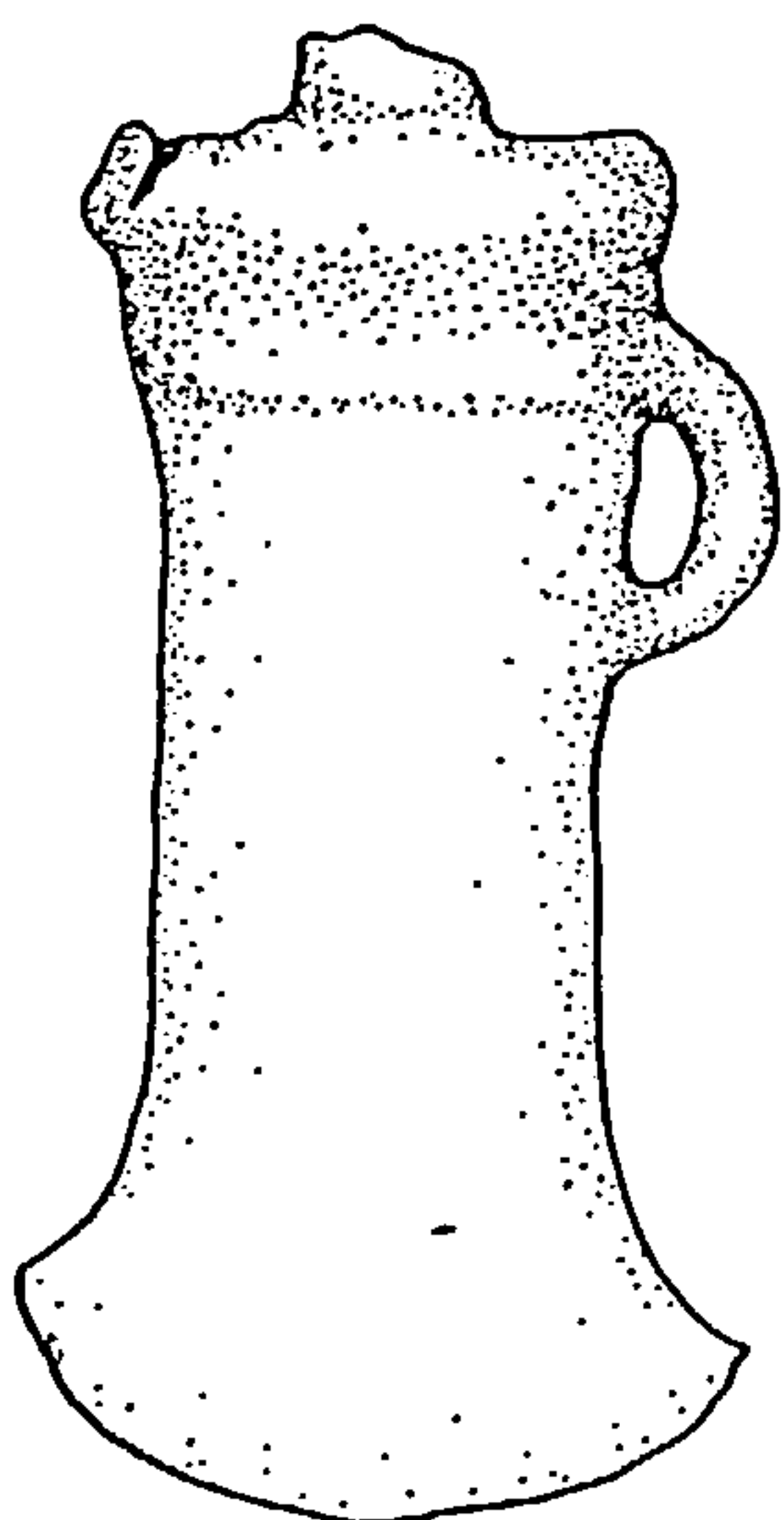


21/08

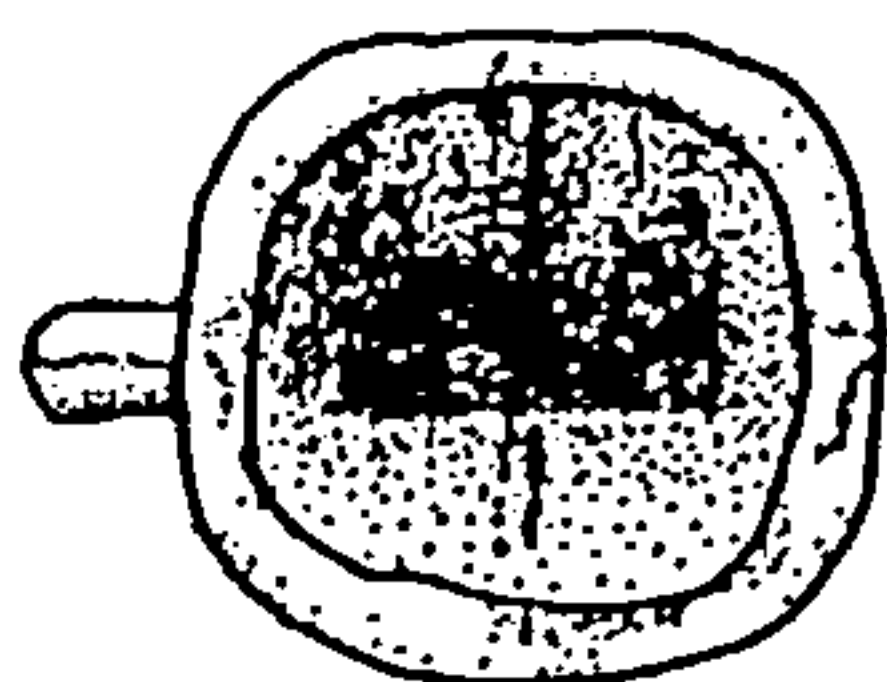


0 2cm

21/09



21/10



21/11

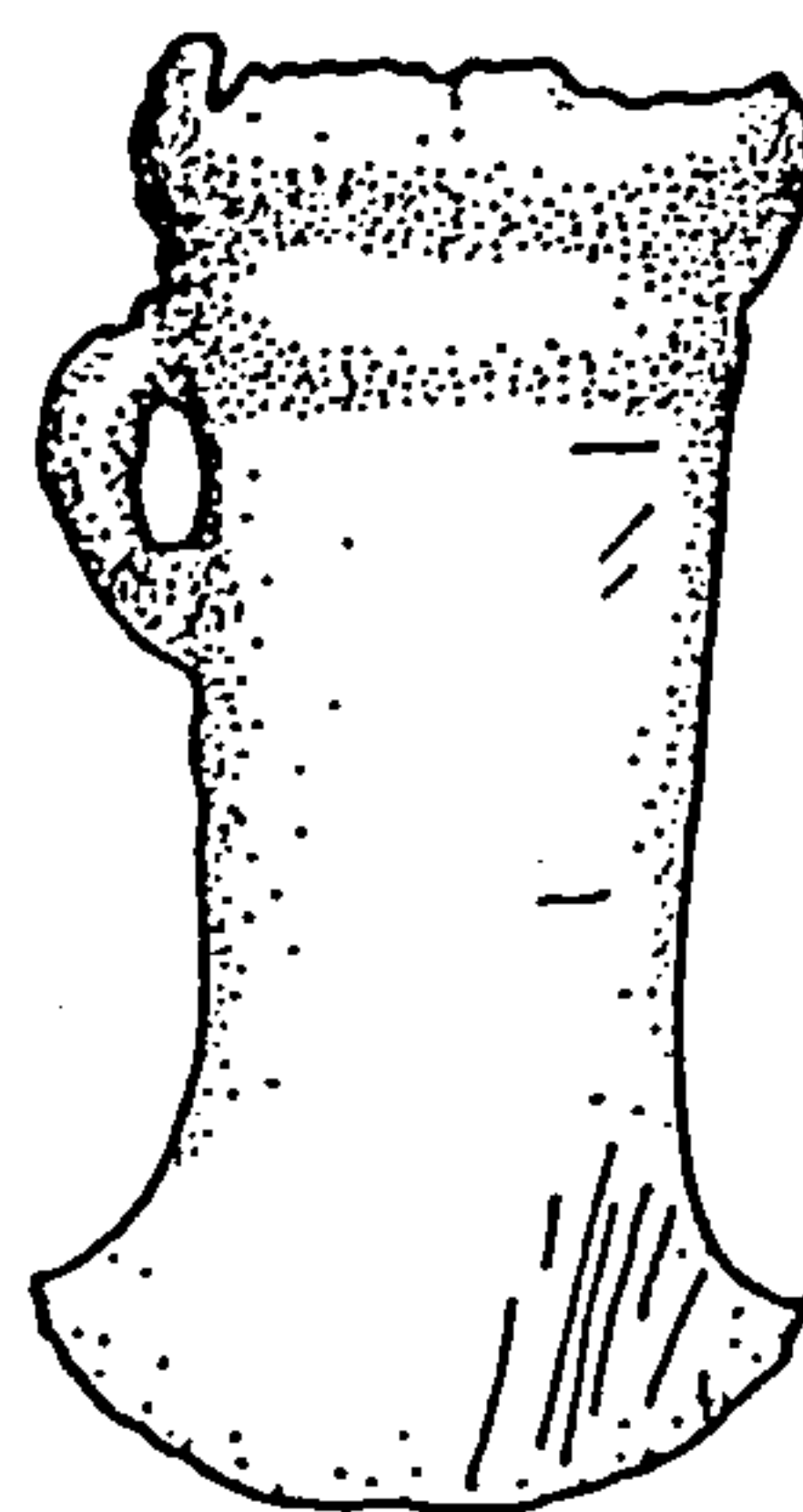
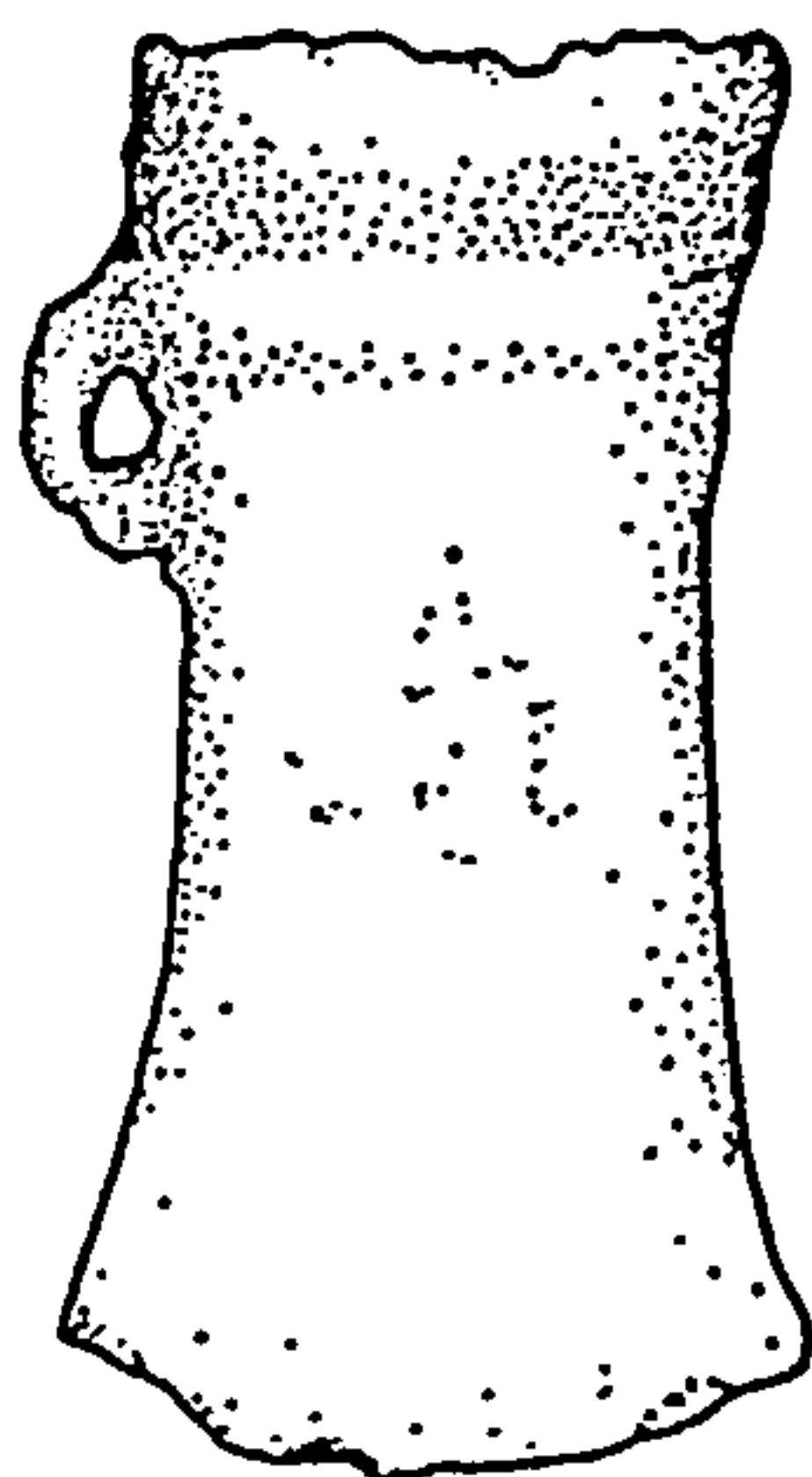
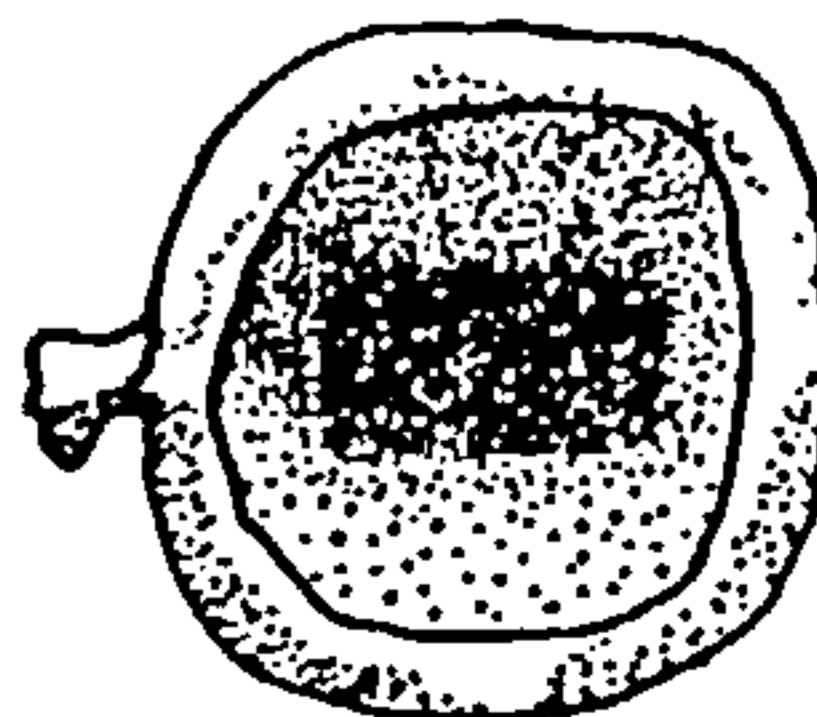
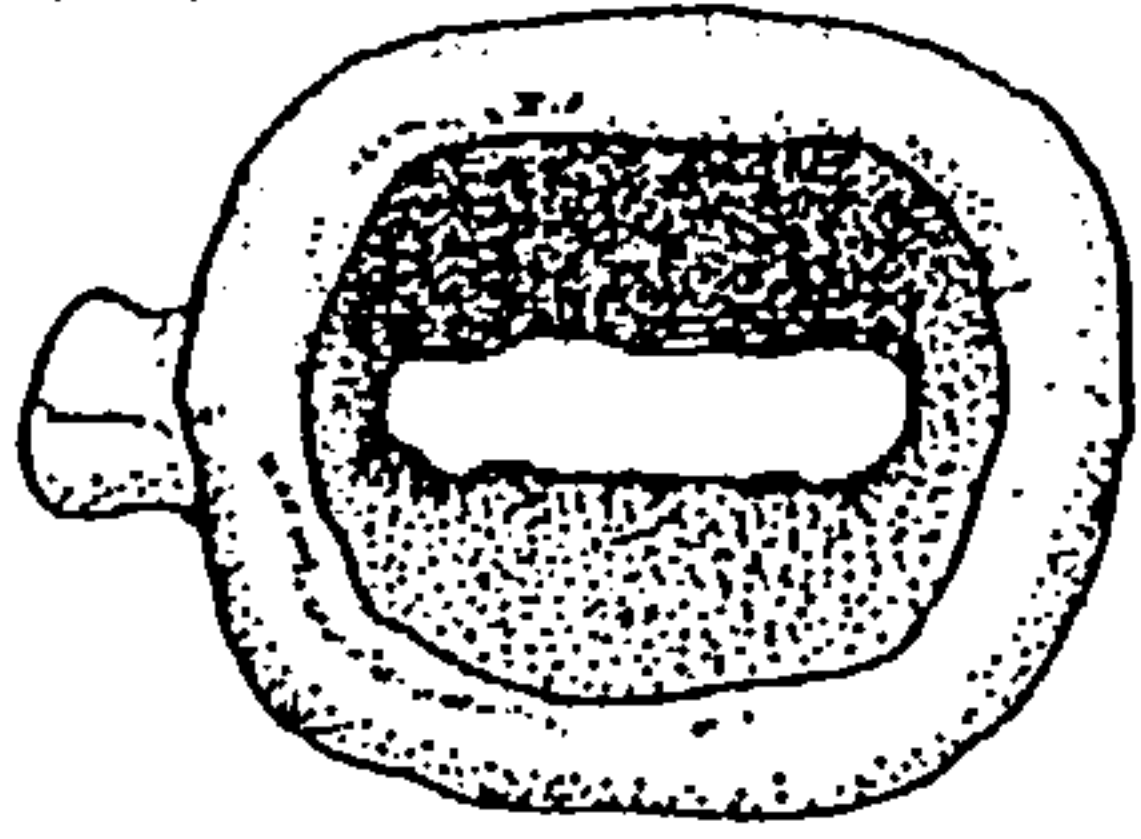
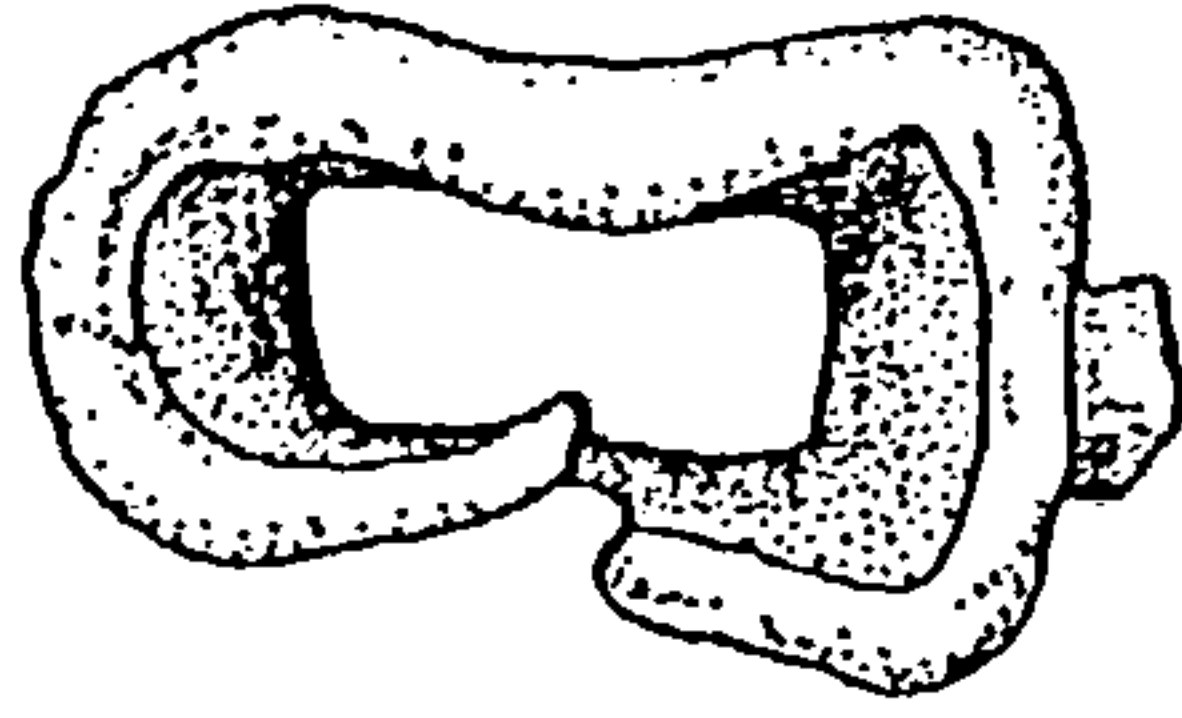


Fig. 79: The Stoke-at-Hoo Hoard (Ref. No. 21): Socketed Axes (ii)

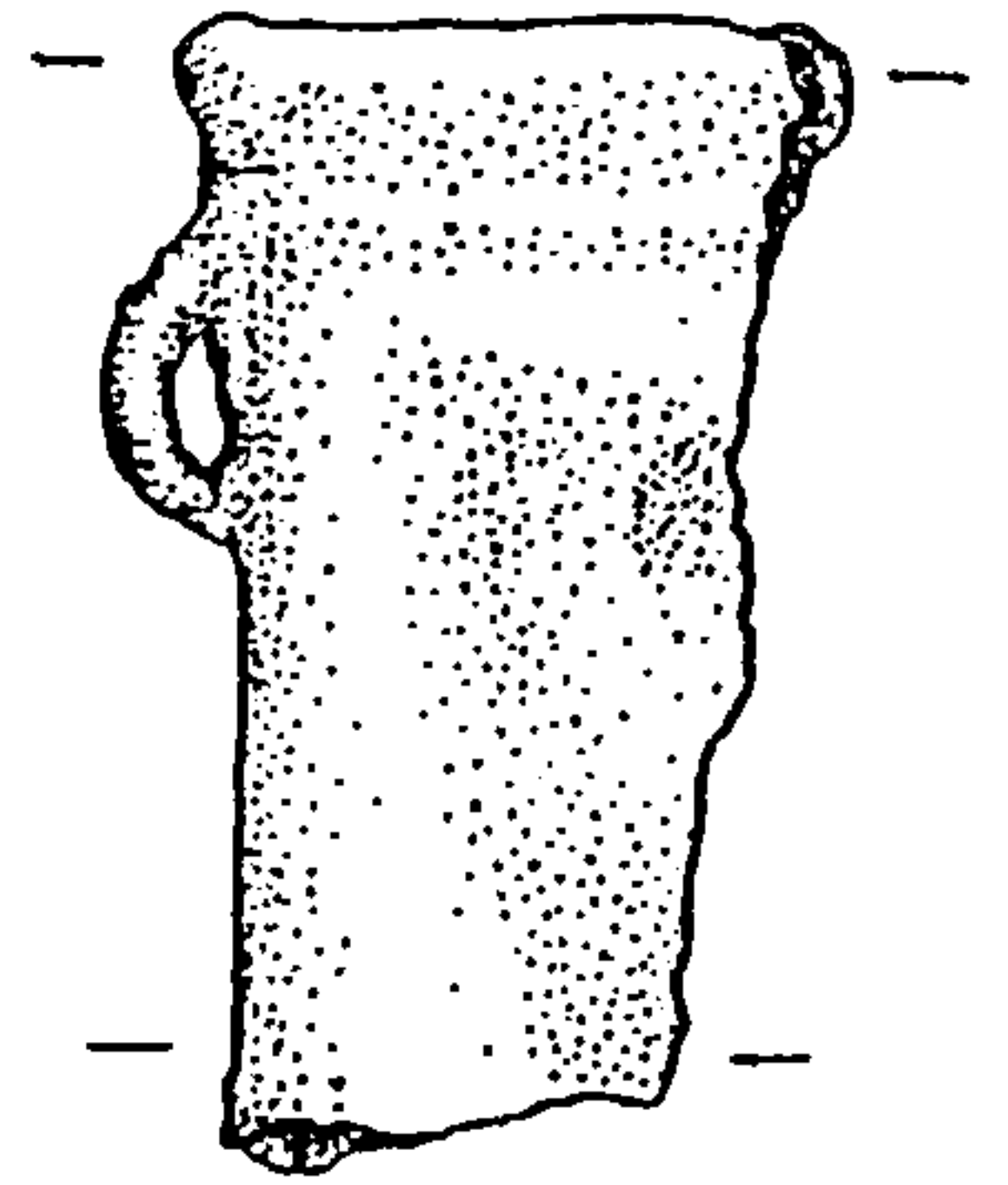
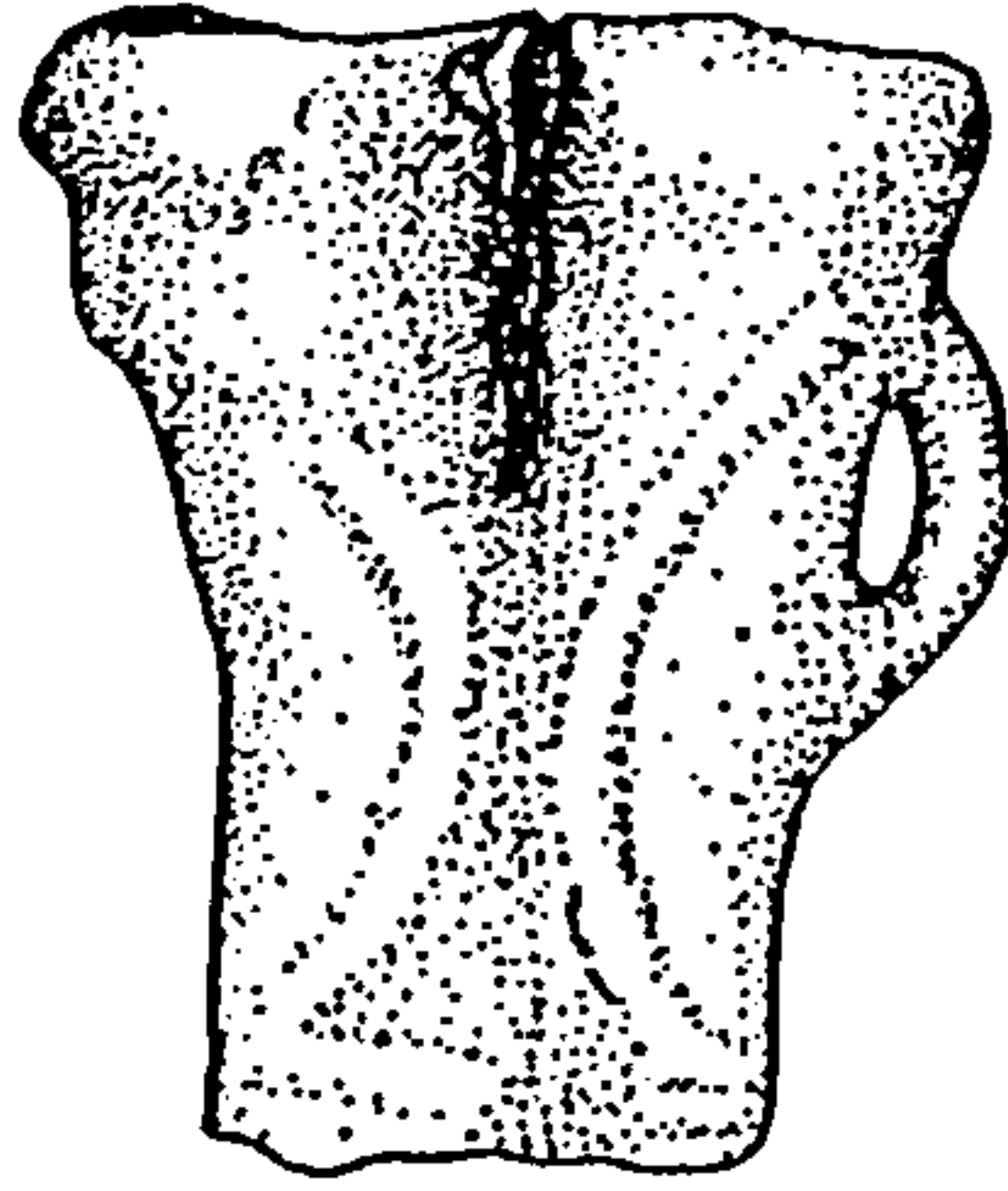
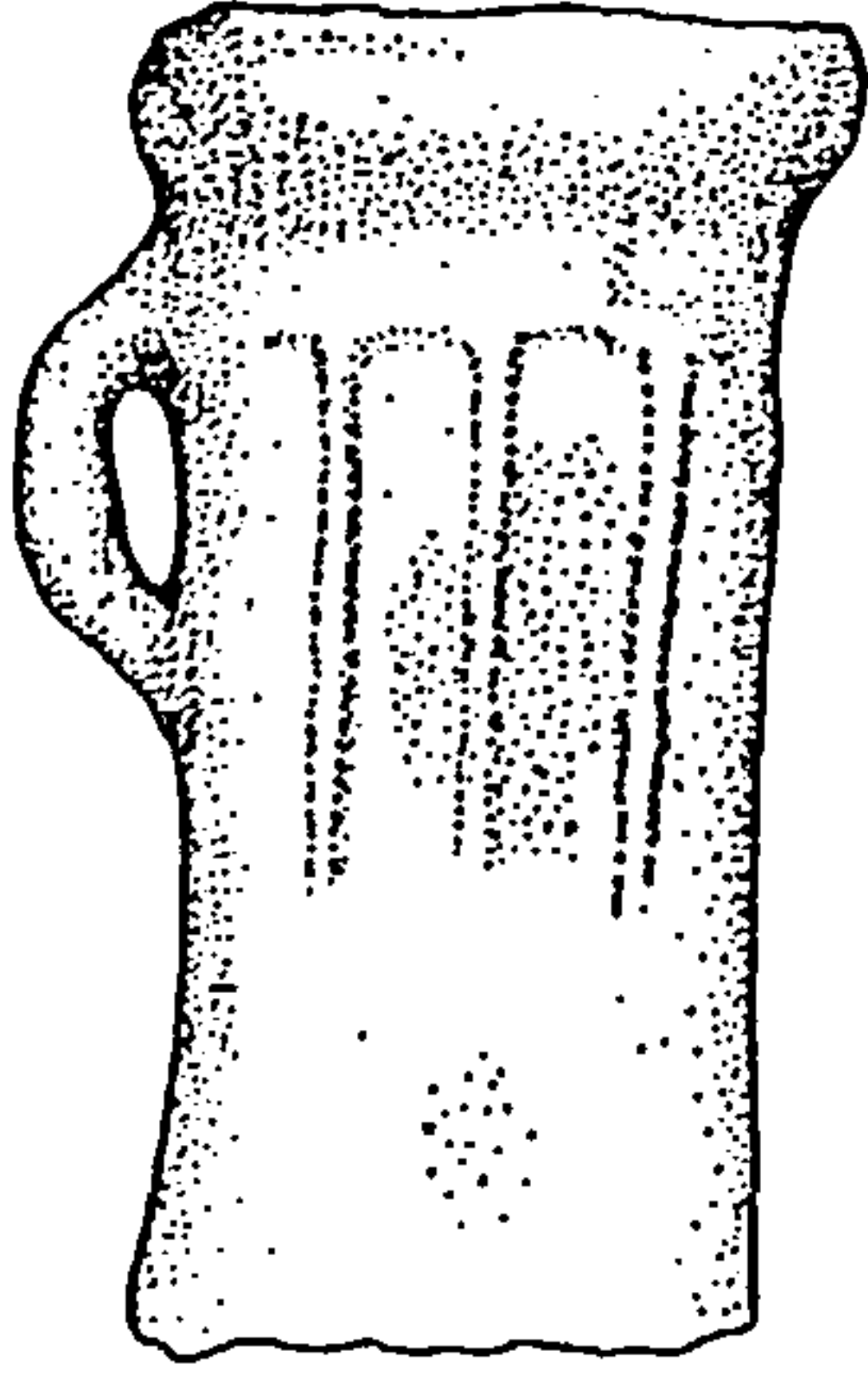
21/12



21/13



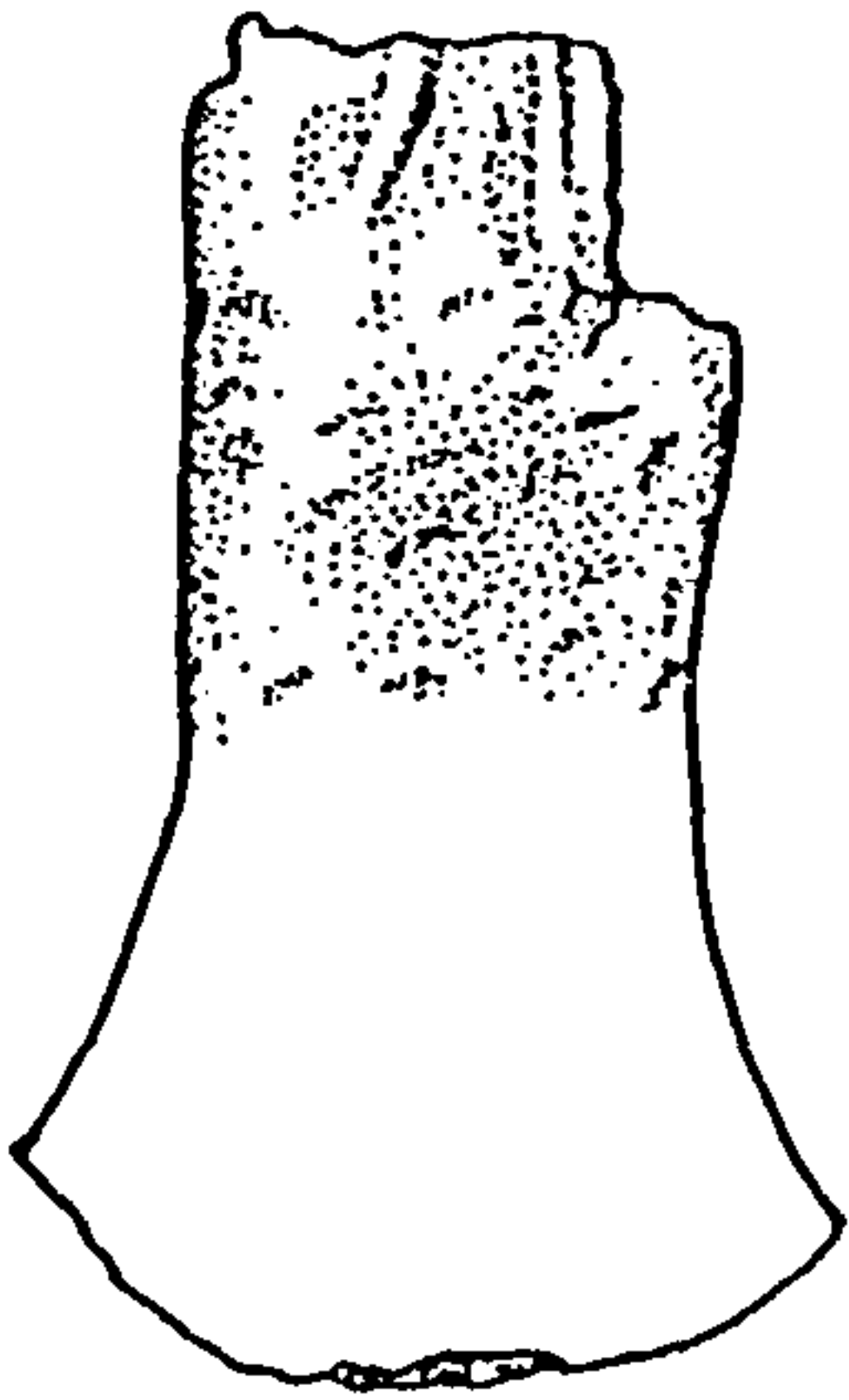
21/14



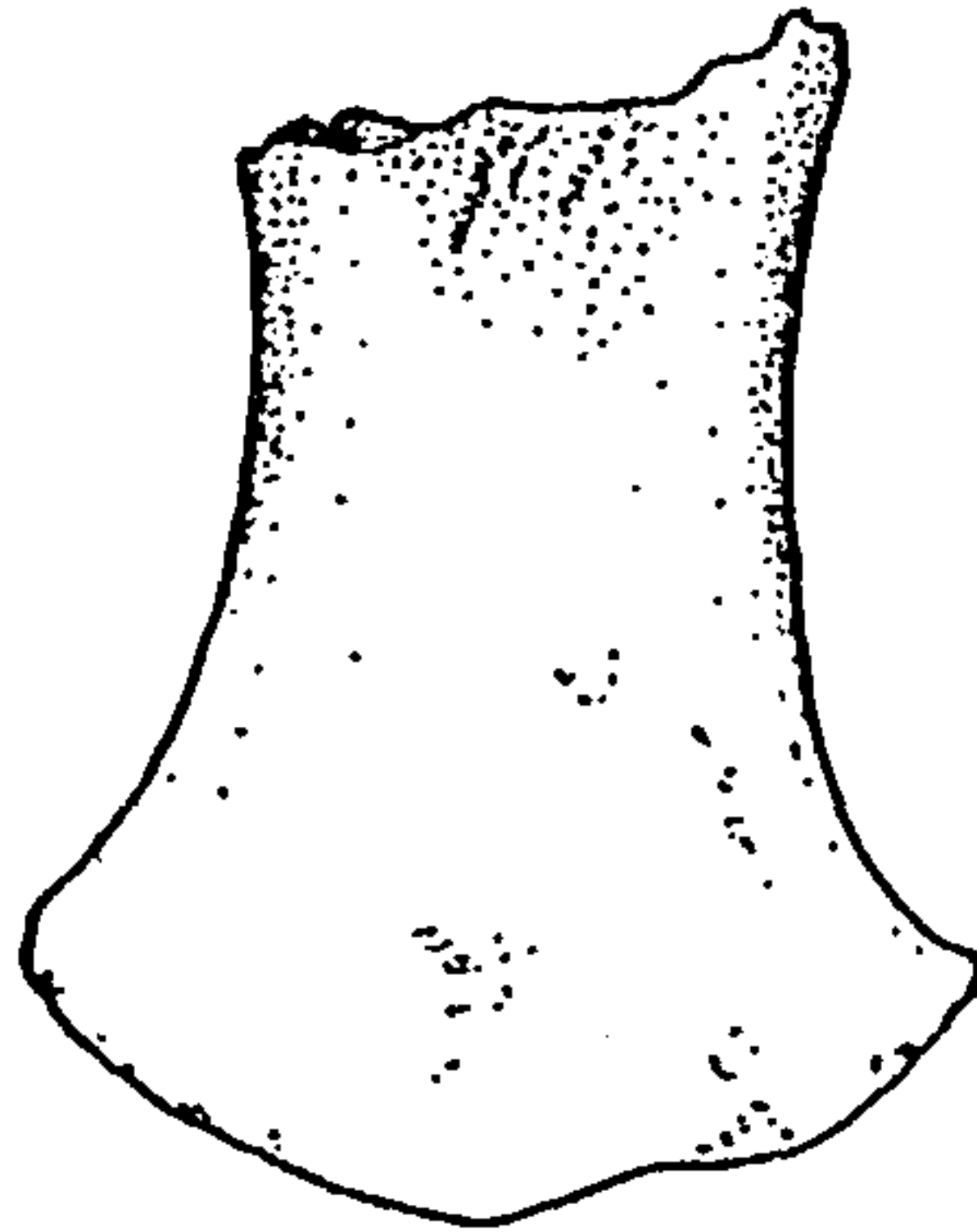
0 2cm



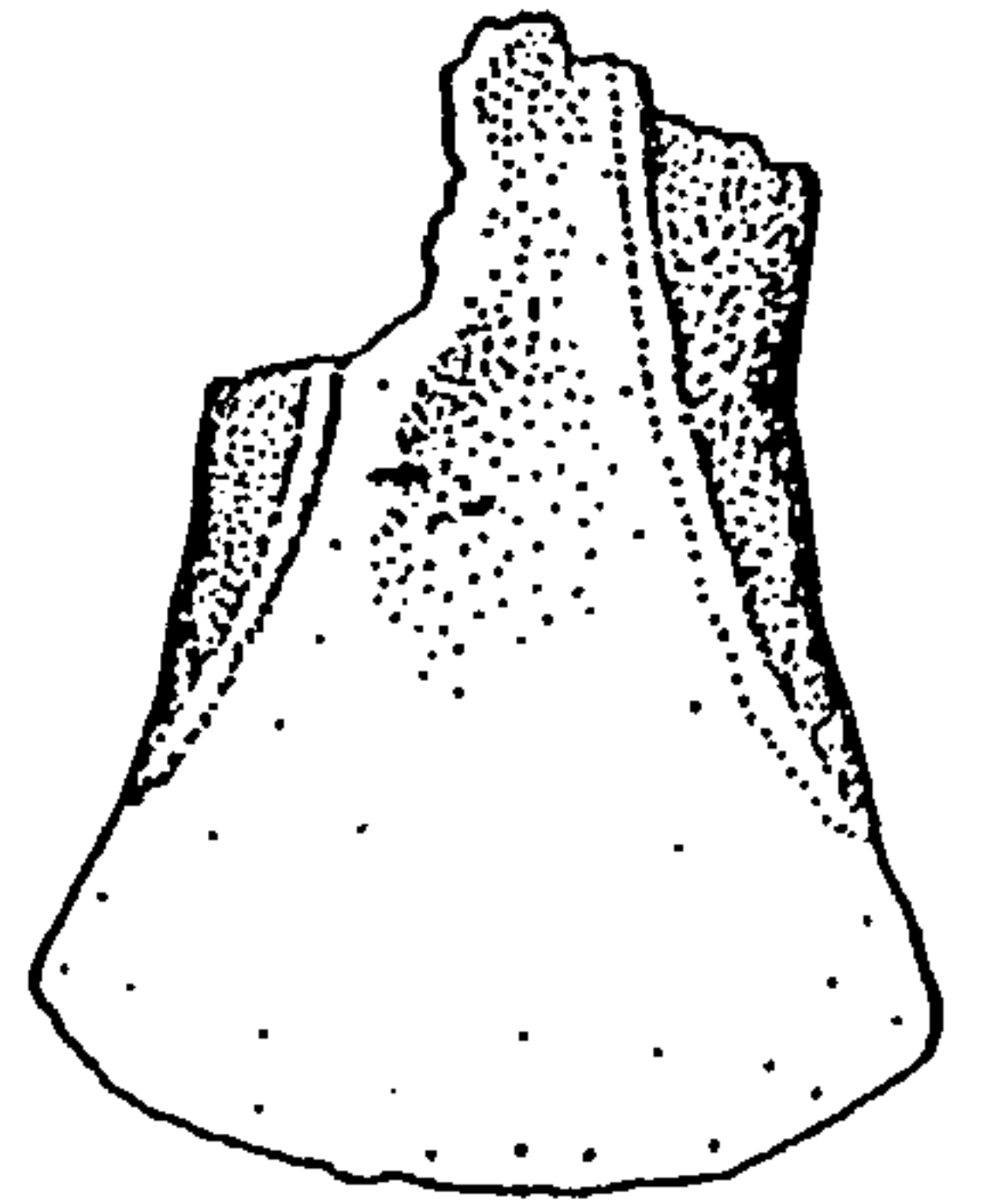
21/15



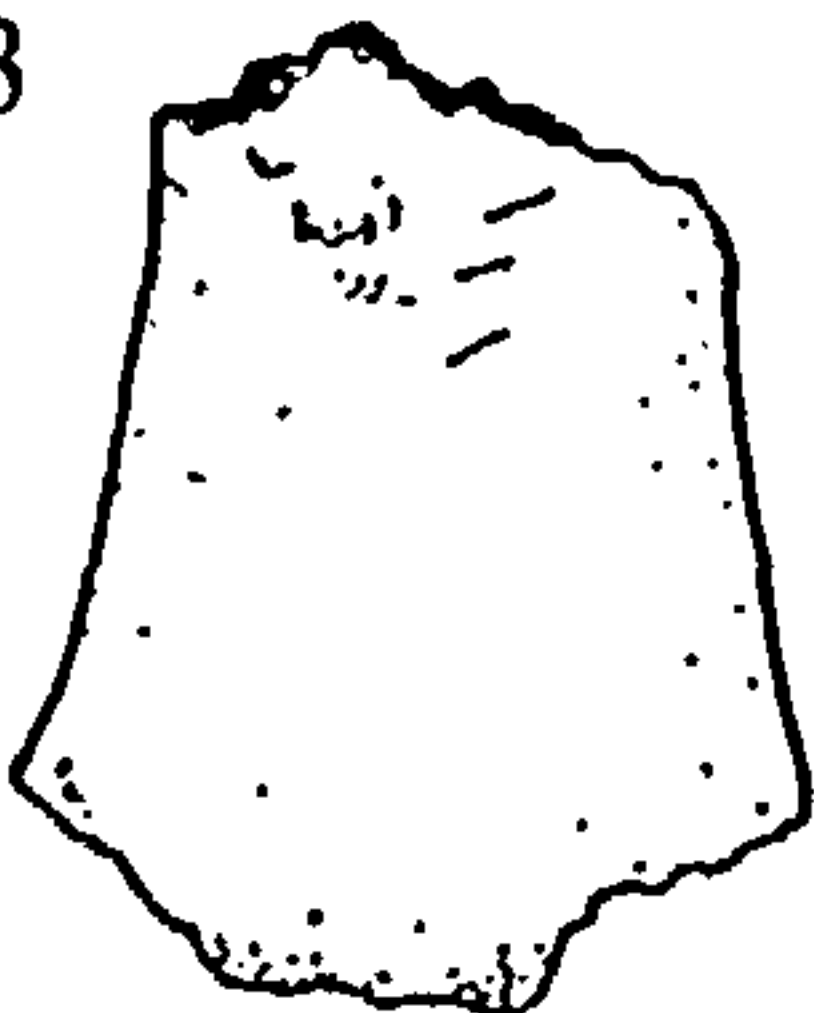
21/16



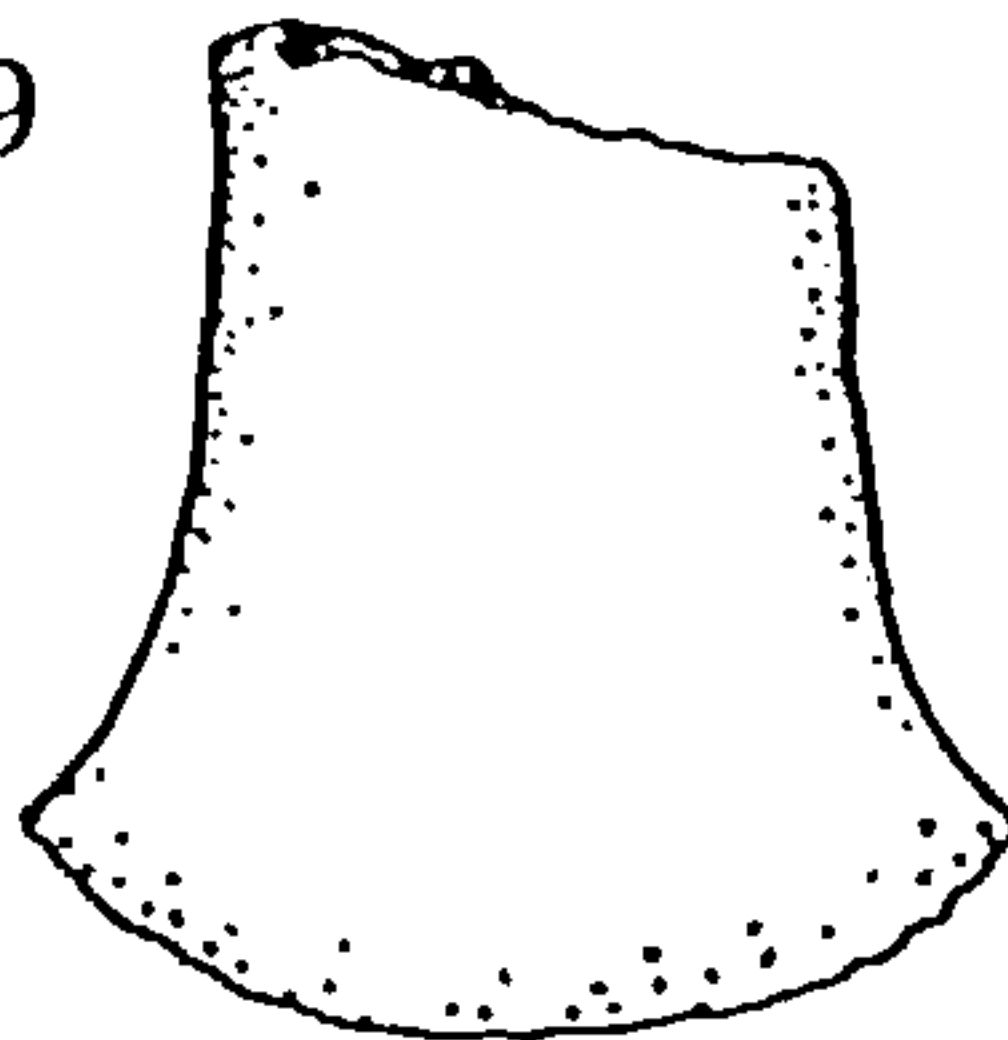
21/17



21/18



21/19



21/20

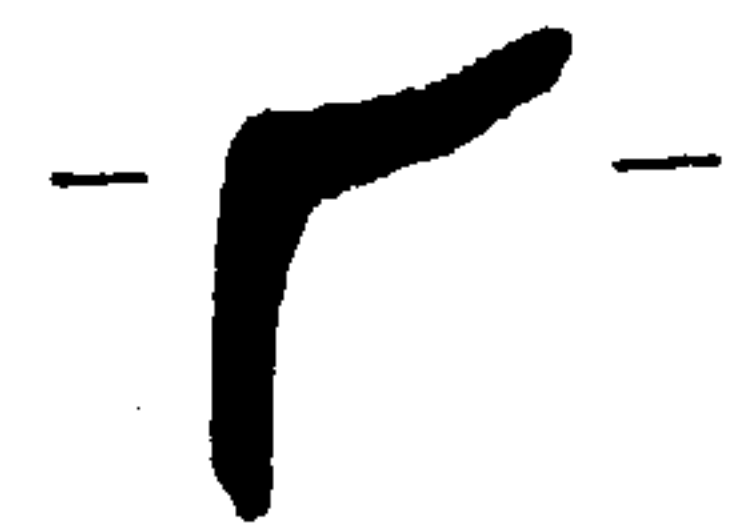
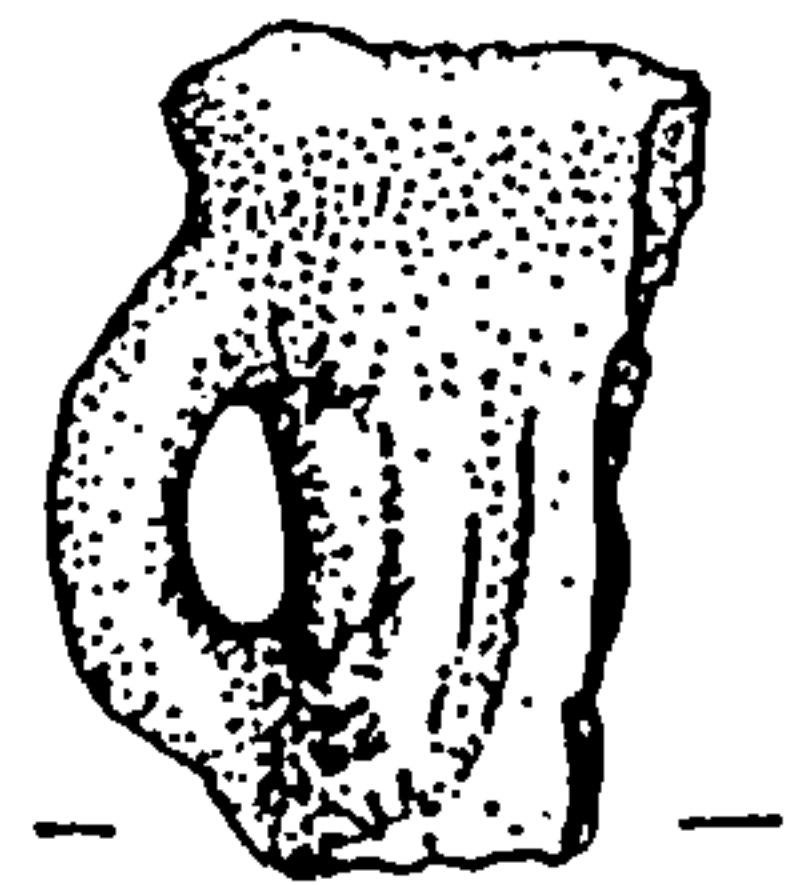
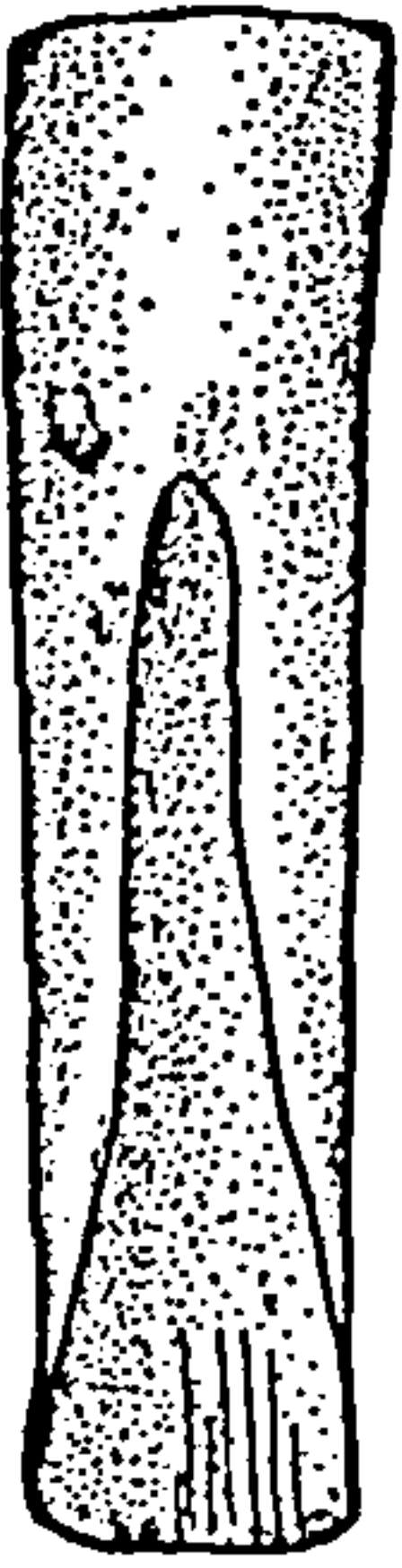


Fig. 80: The Stoke-at-Hoo Hoard (Ref. No. 21): Socketed Axe Fragments

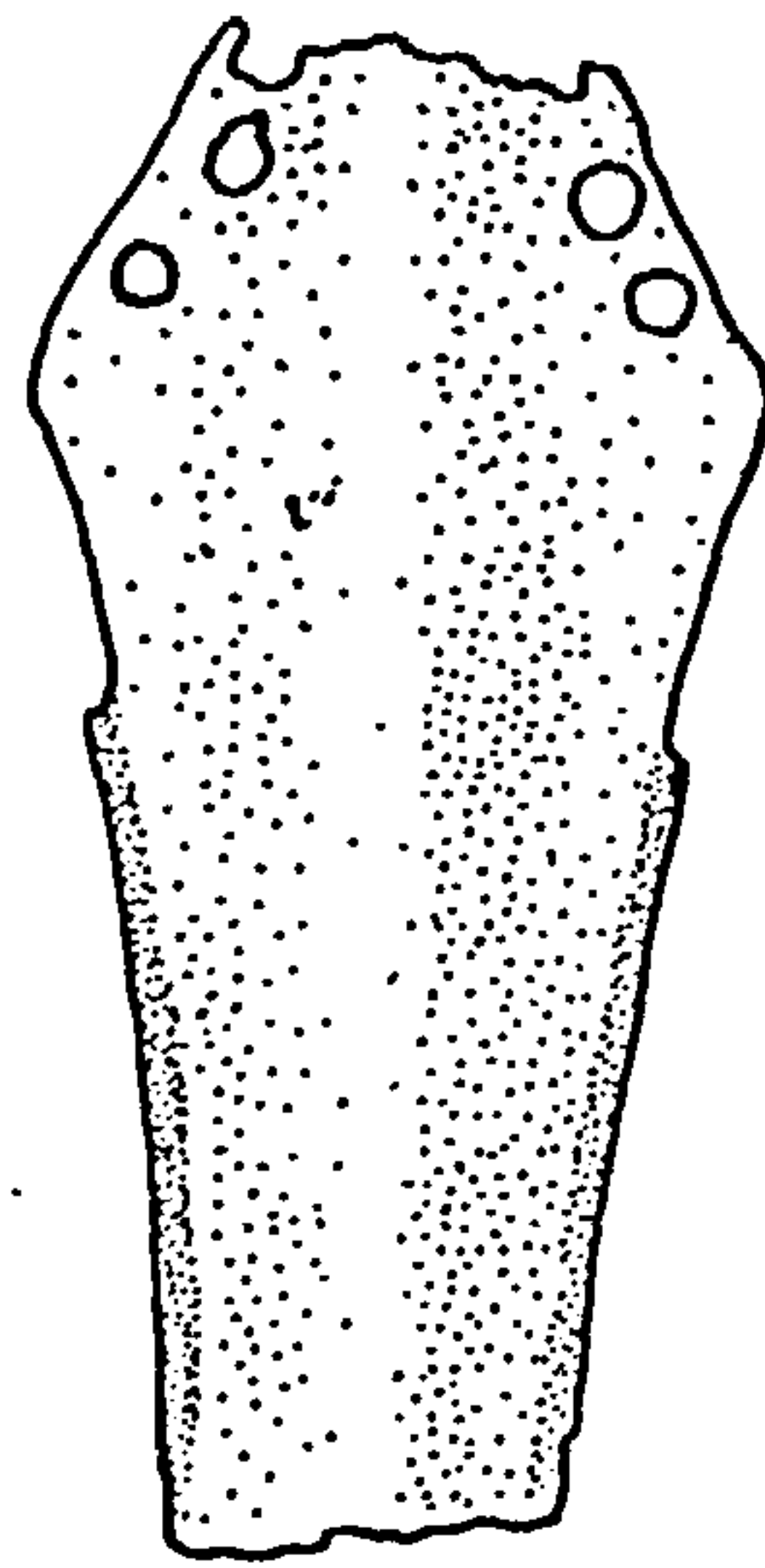
21/21



21/22

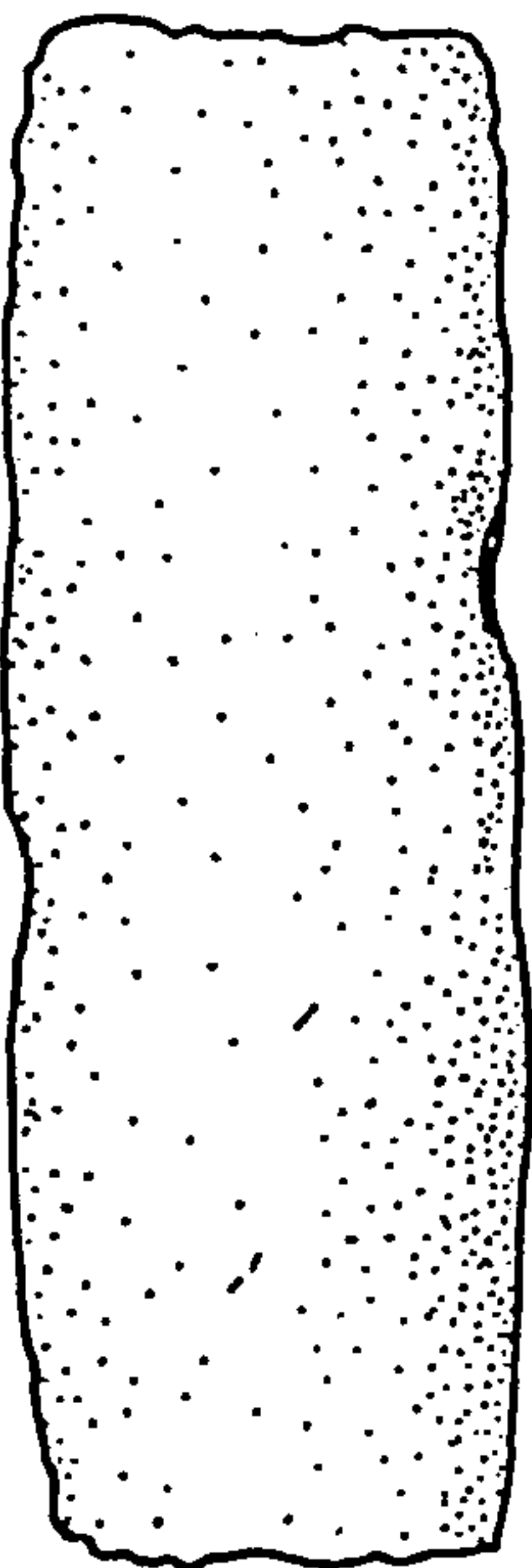


21/23

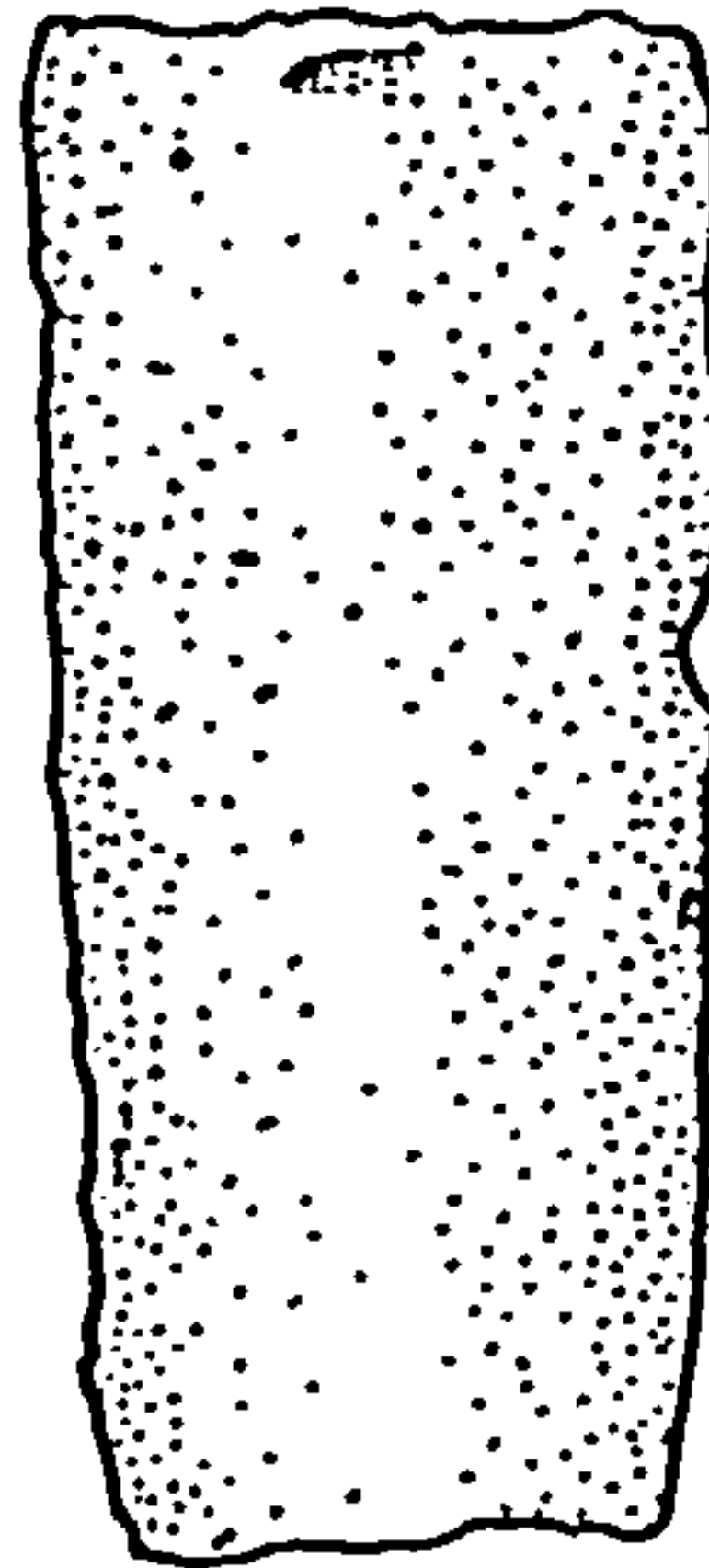


0 2cm

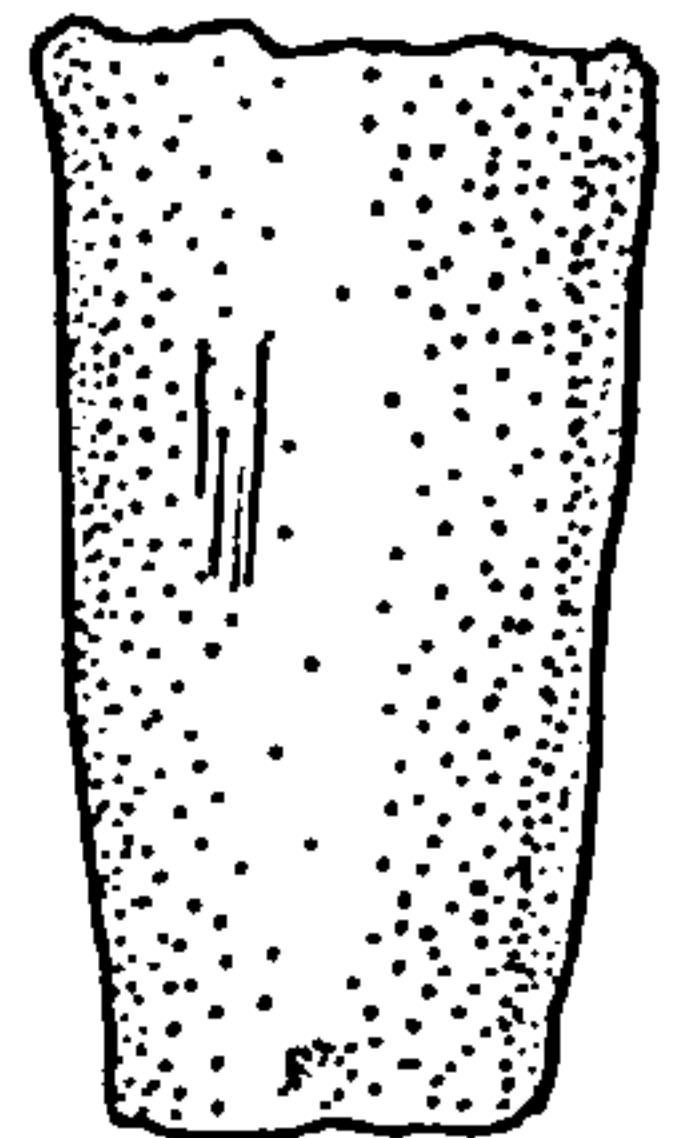
21/24



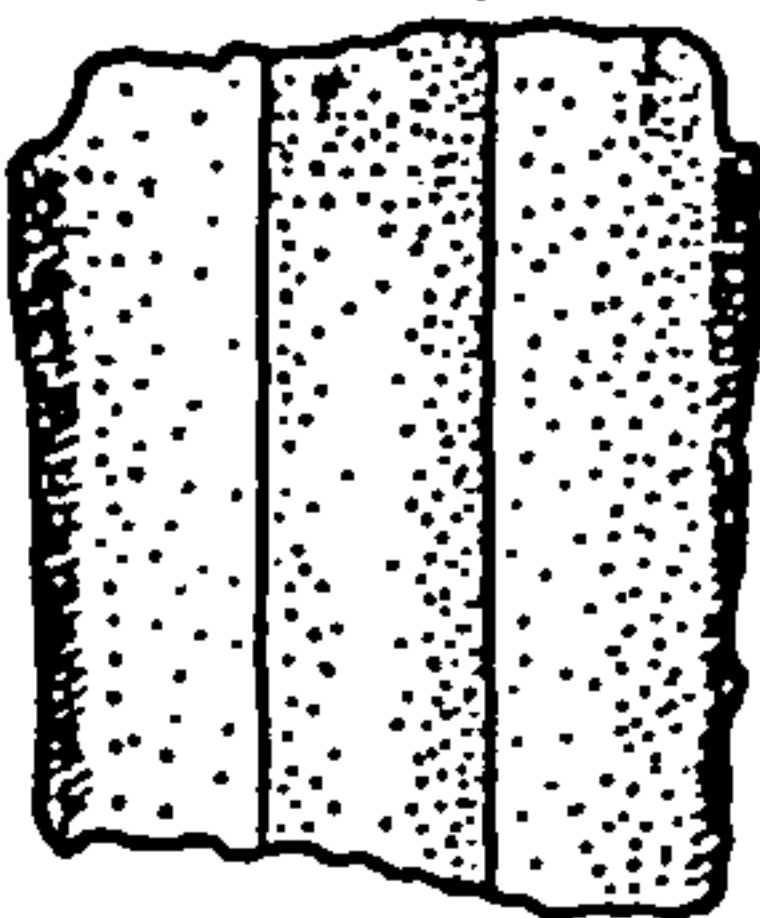
21/25



21/26



21/27



21/28

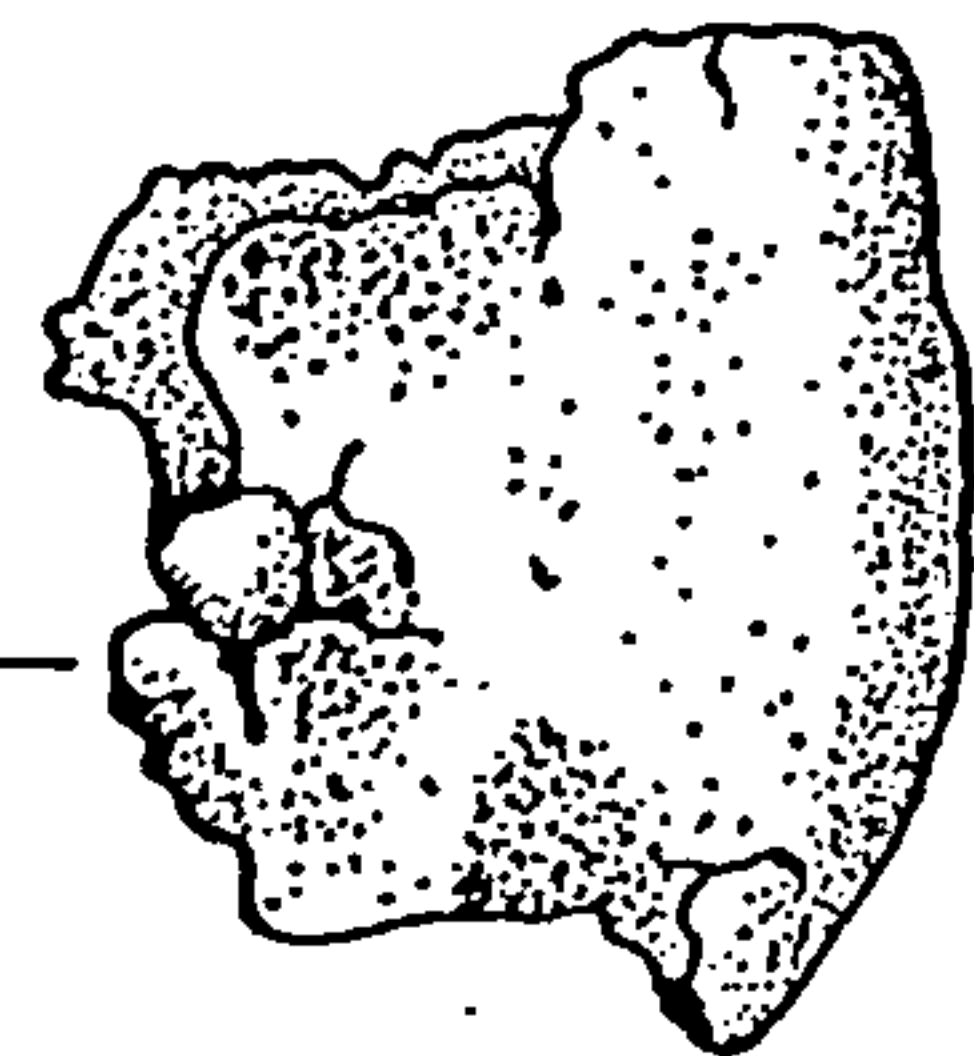
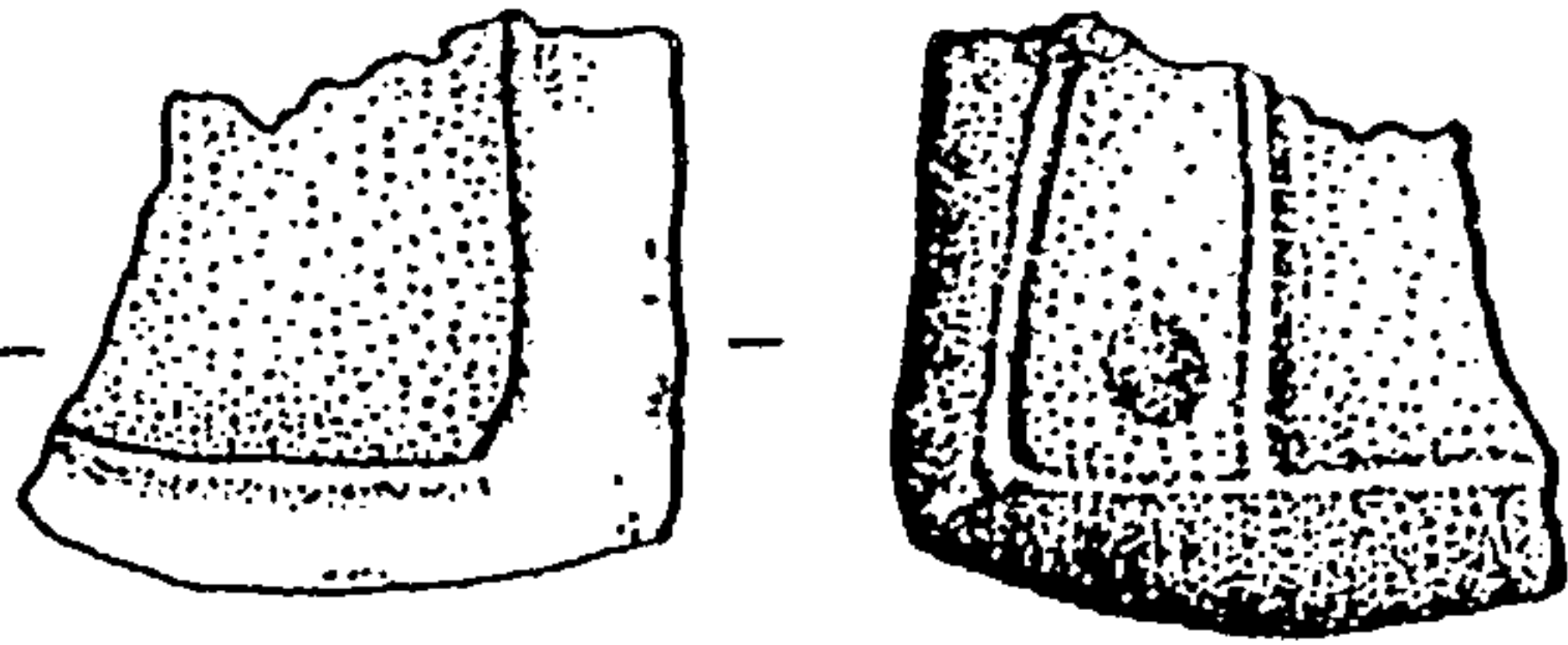
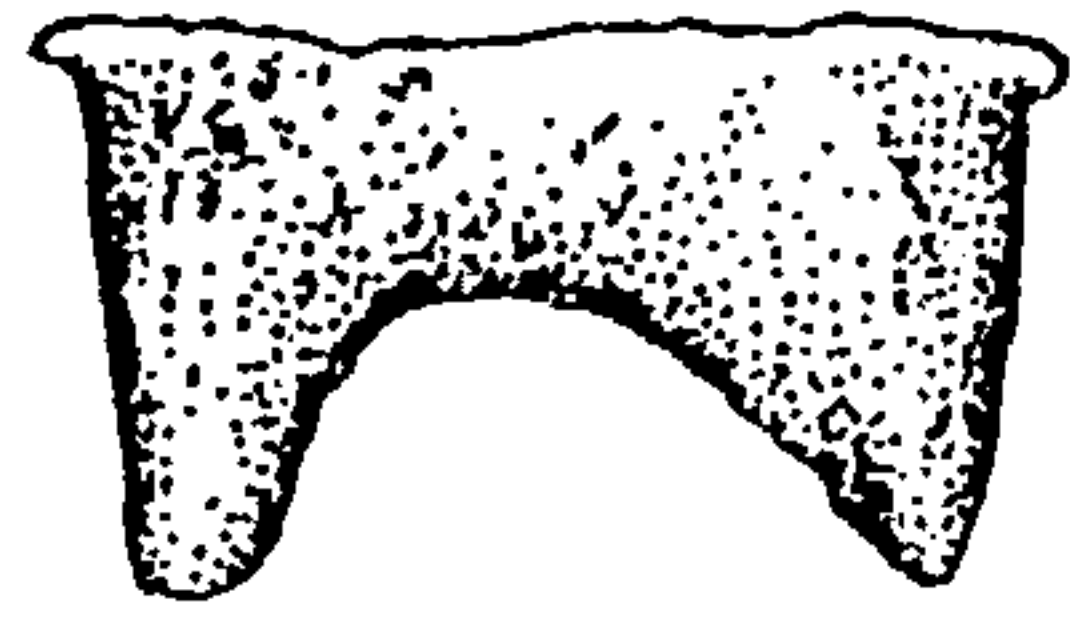


Fig. 81: The Stoke-at-Hoo Hoard (Ref. No. 21): Small Tools, Weaponry and Decorative Fittings

21/29

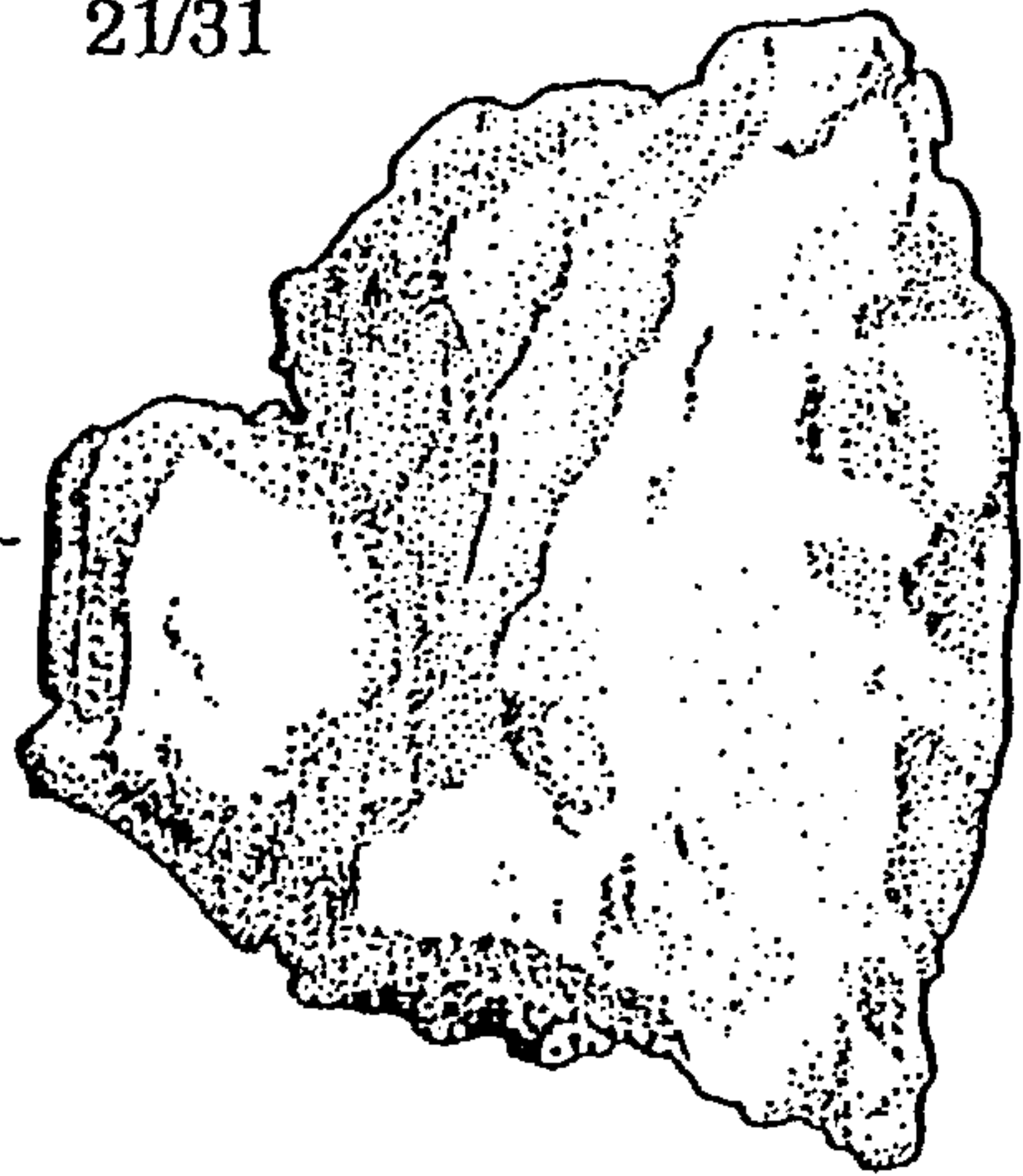


21/30

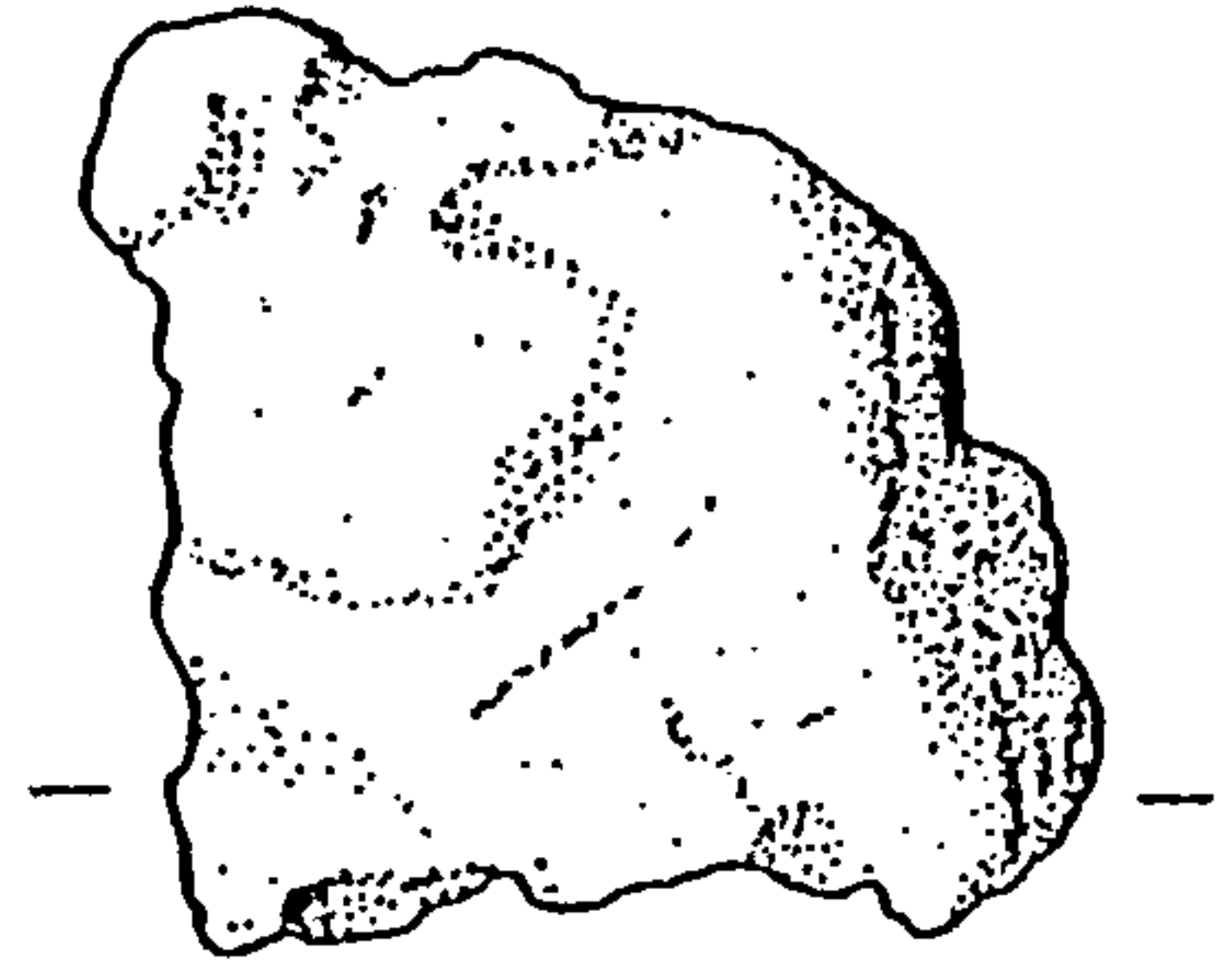


0 2cm

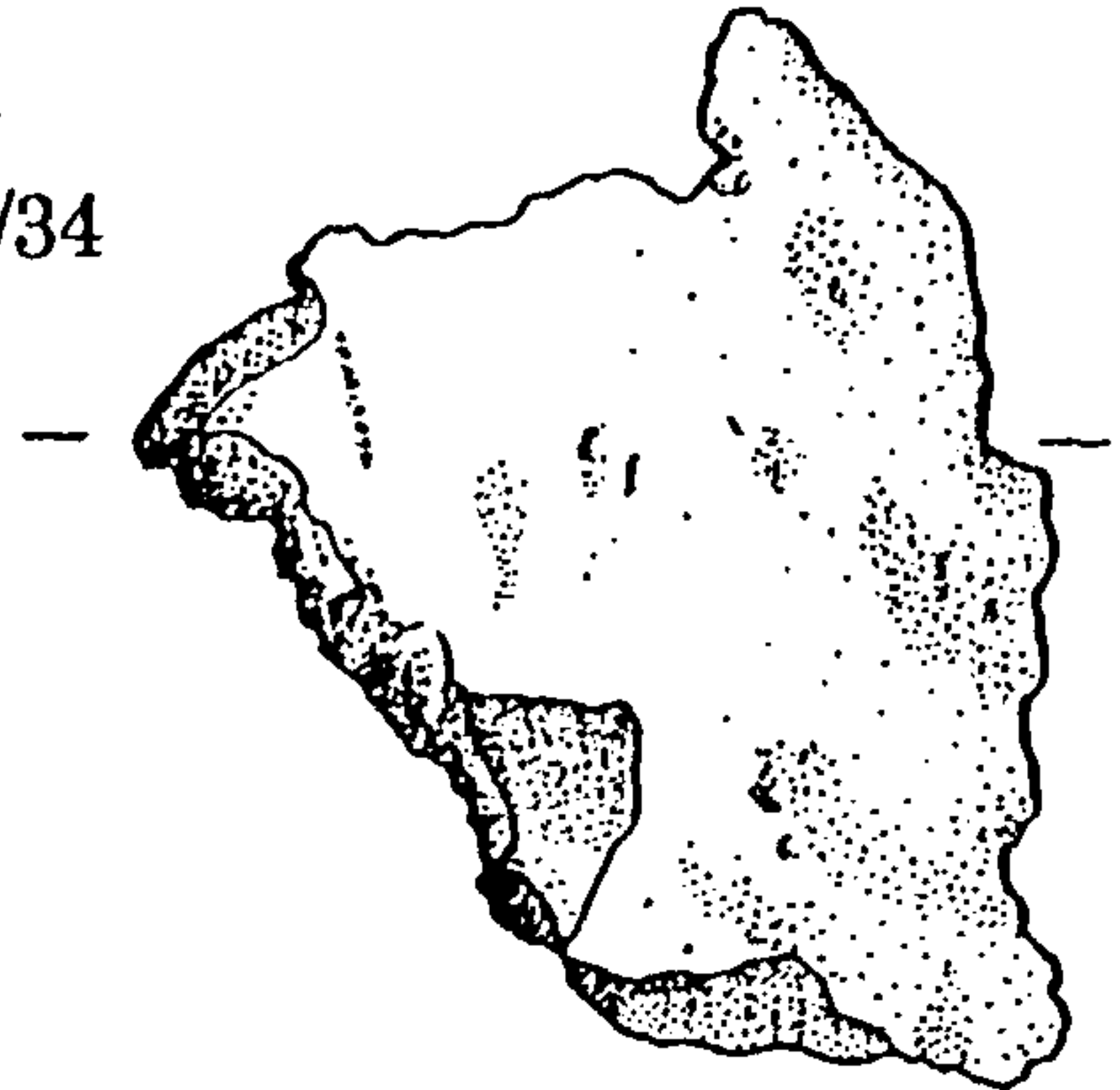
21/31



21/32



21/34



21/33

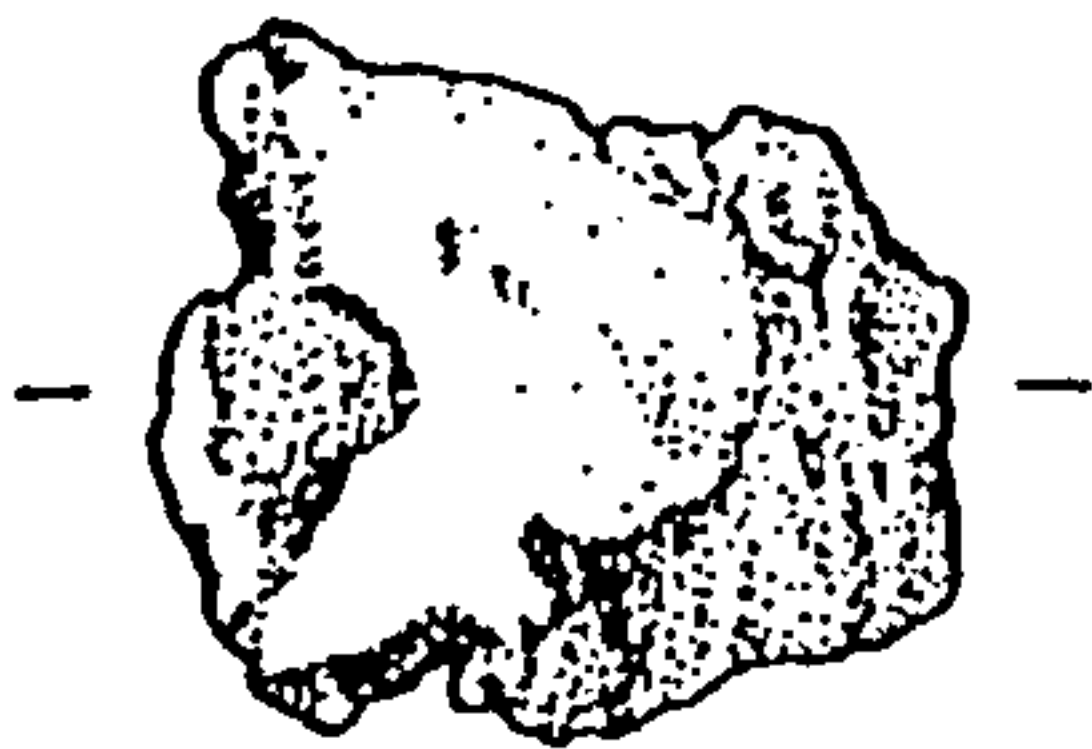


Fig. 82: The Stoke-at-Hoo Hoard (Ref. No. 21): Mould Fragment, Casting Debris and Ingot Metal (i)

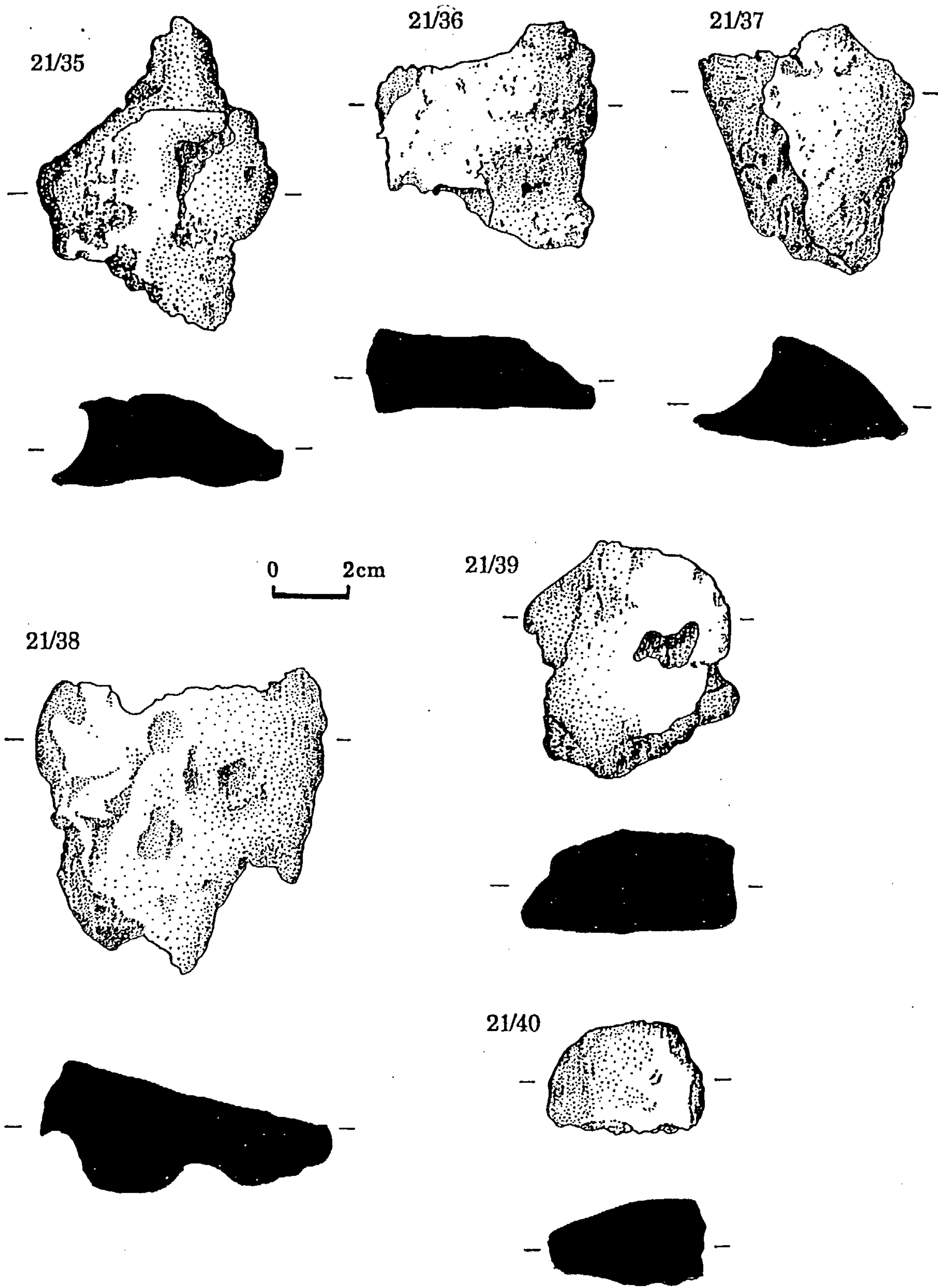


Fig. 83: The Stoke-at-Hoo Hoard (Ref. No. 21): Ingot Metal (ii)

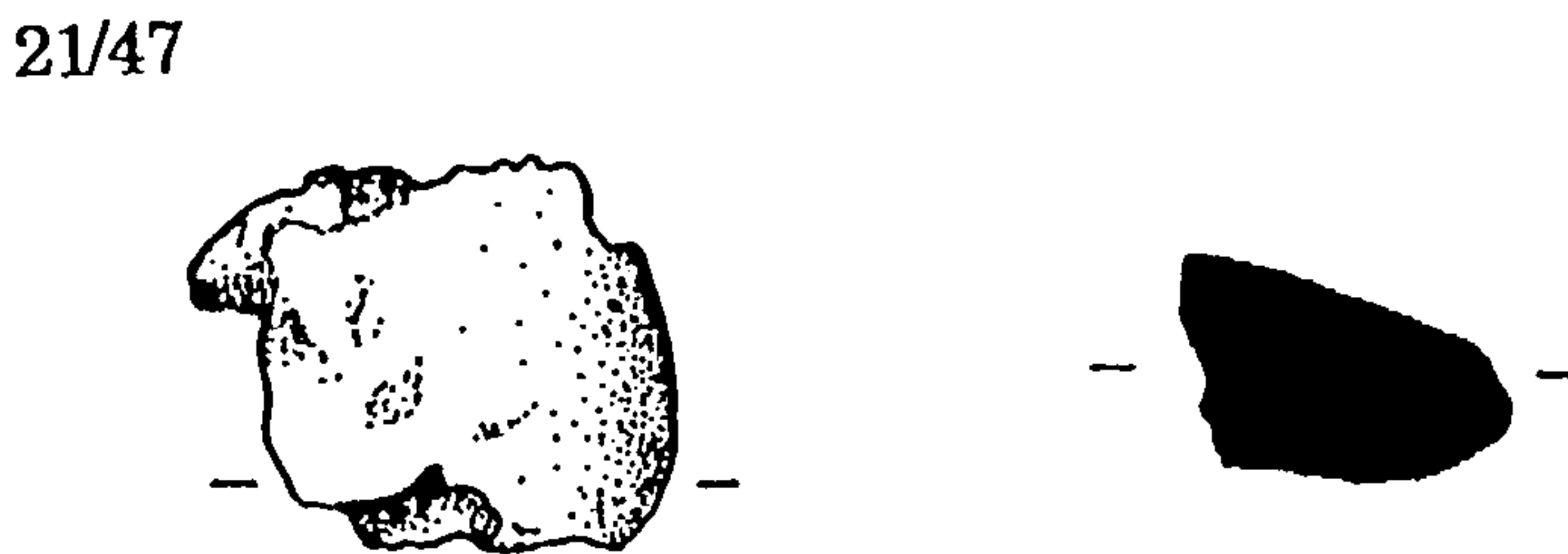
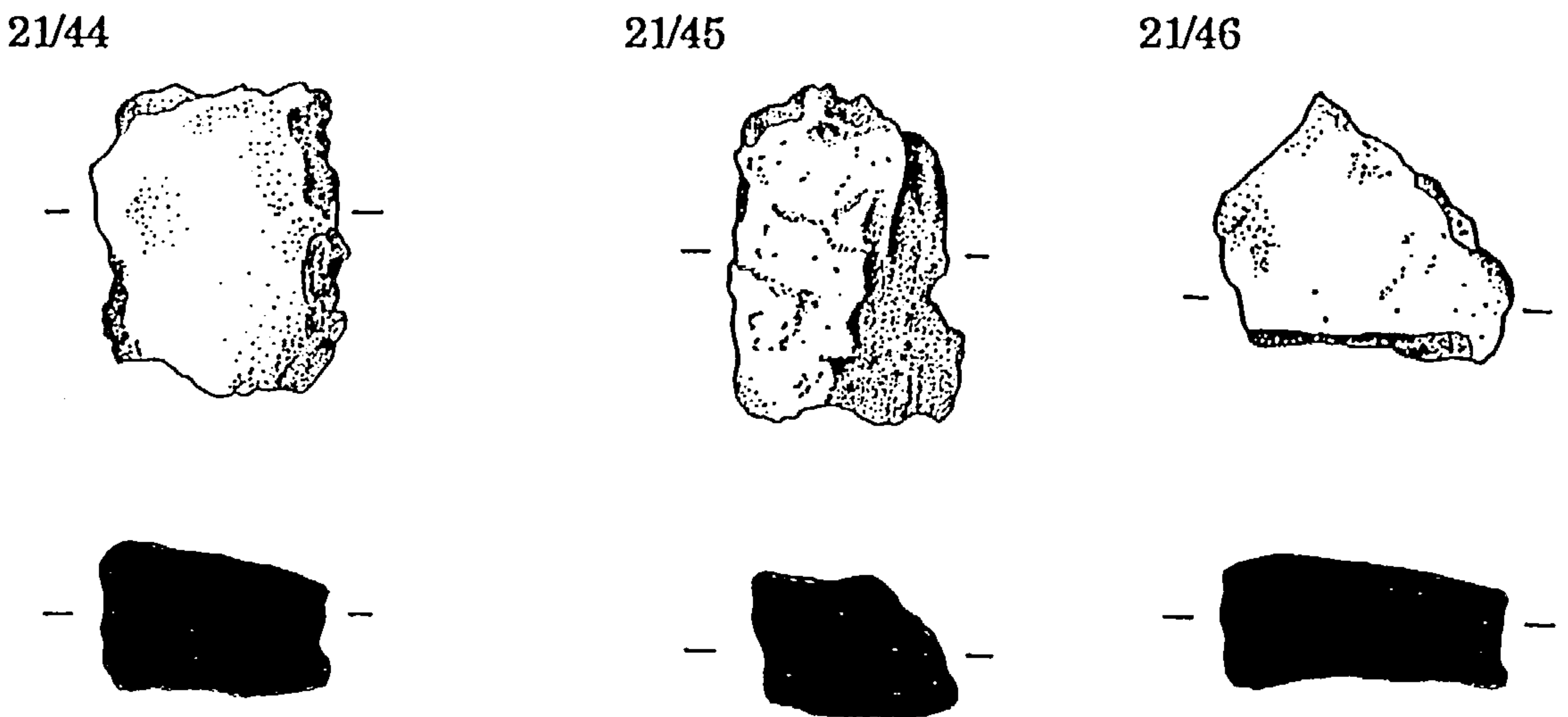
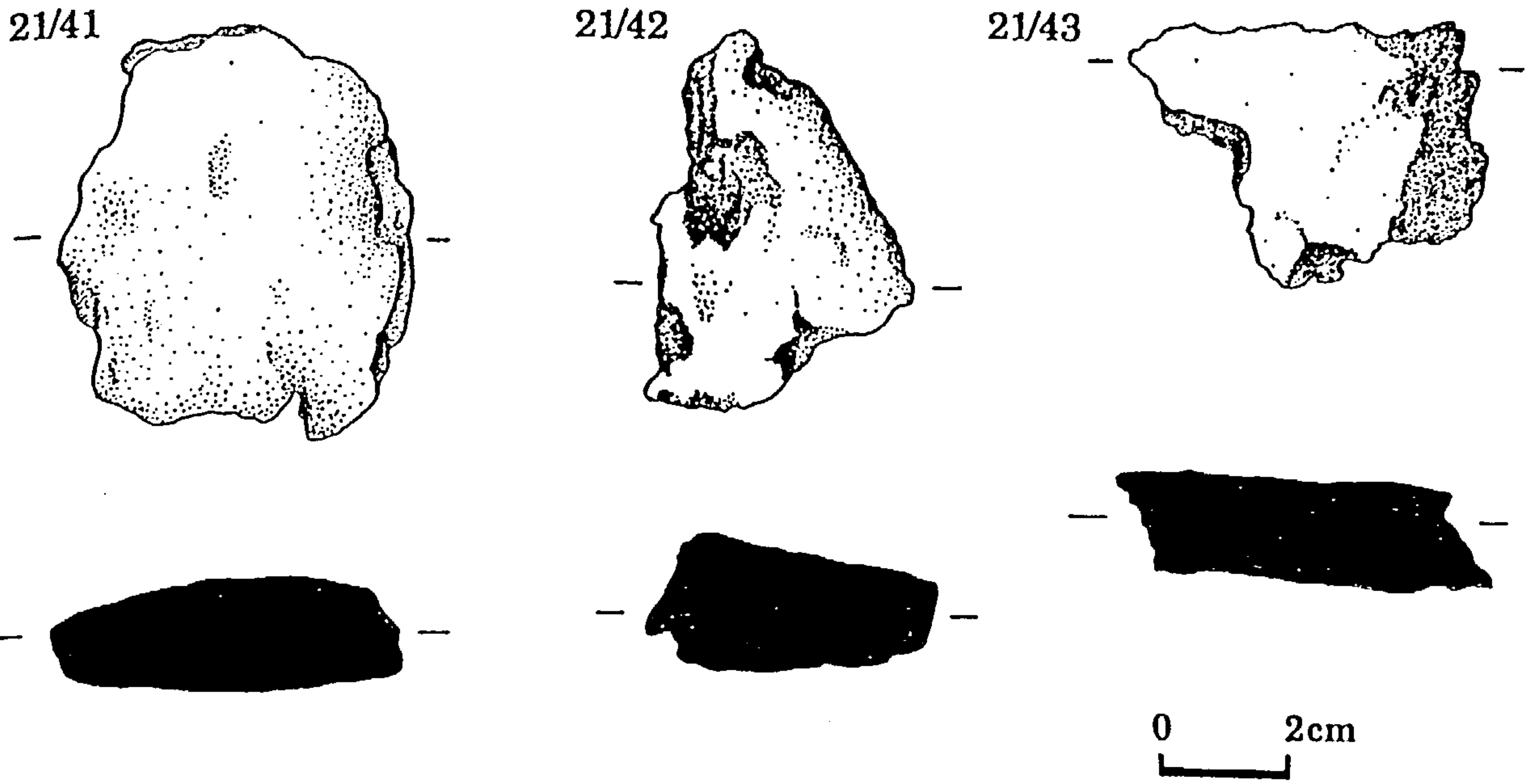
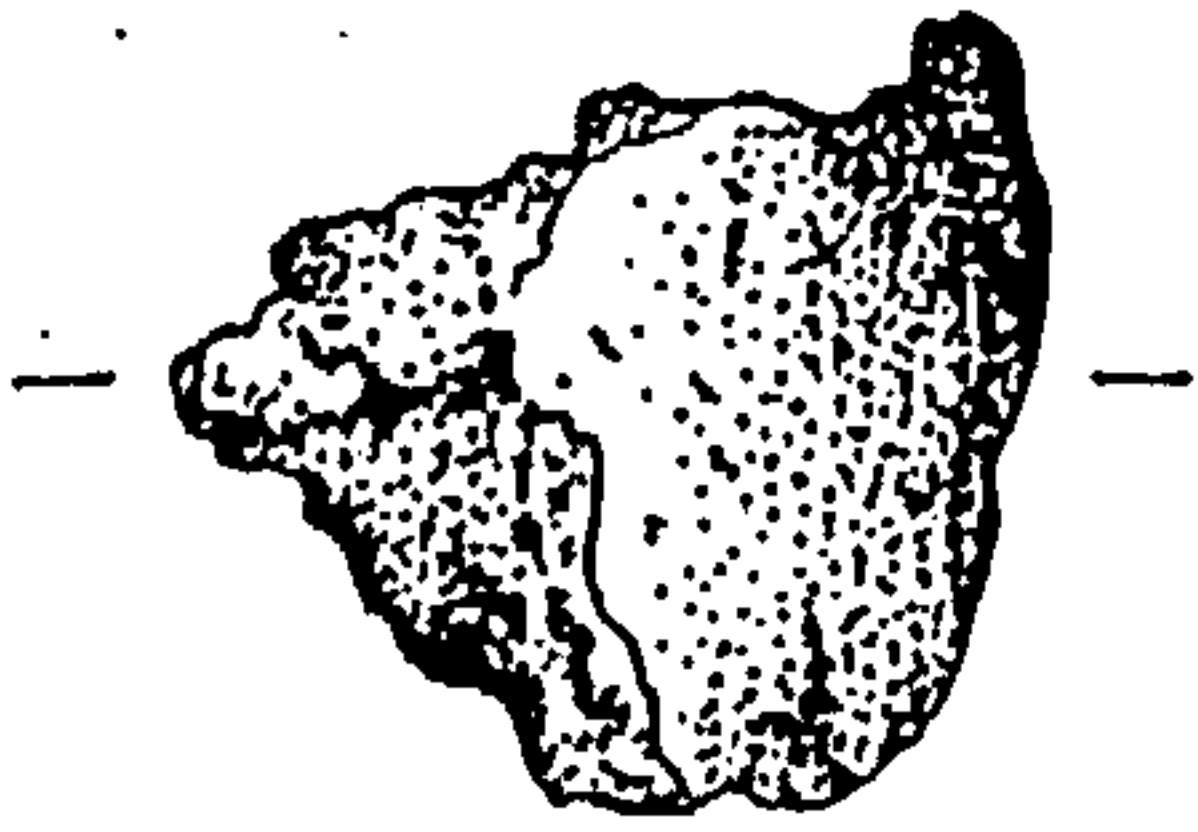


Fig. 84 The Stoke-at-Hoo Hoard (Ref. No. 21): Ingot Metal (iii)

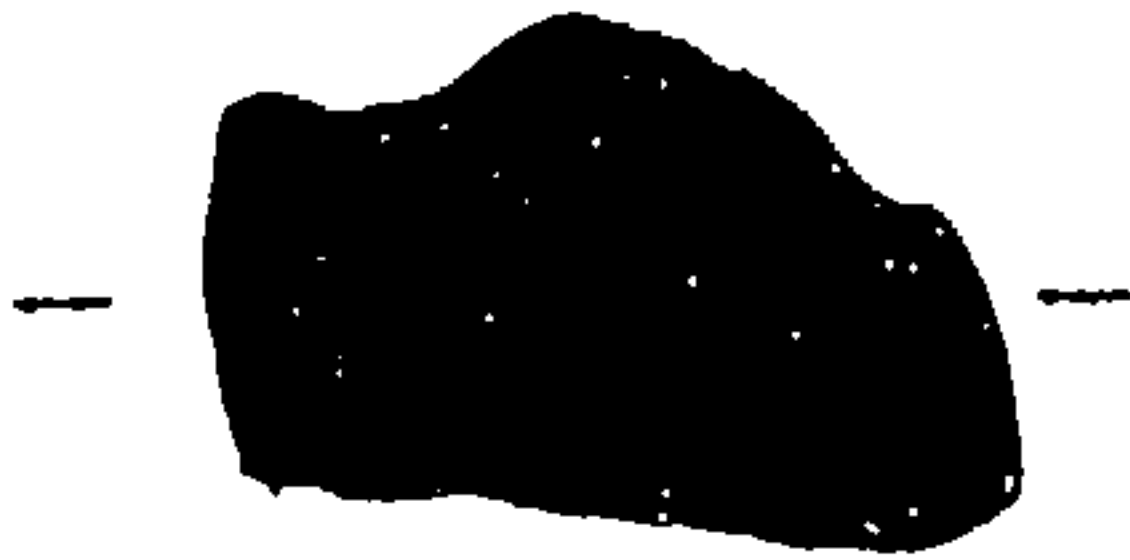
21/48



21/49

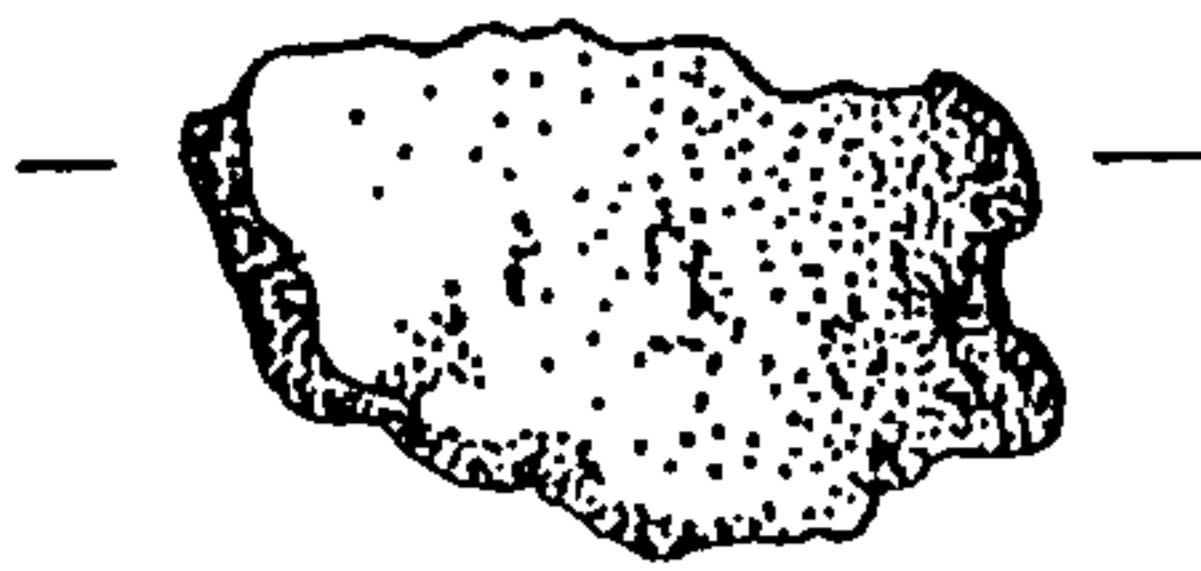


21/50



0 2cm

21/51



21/52

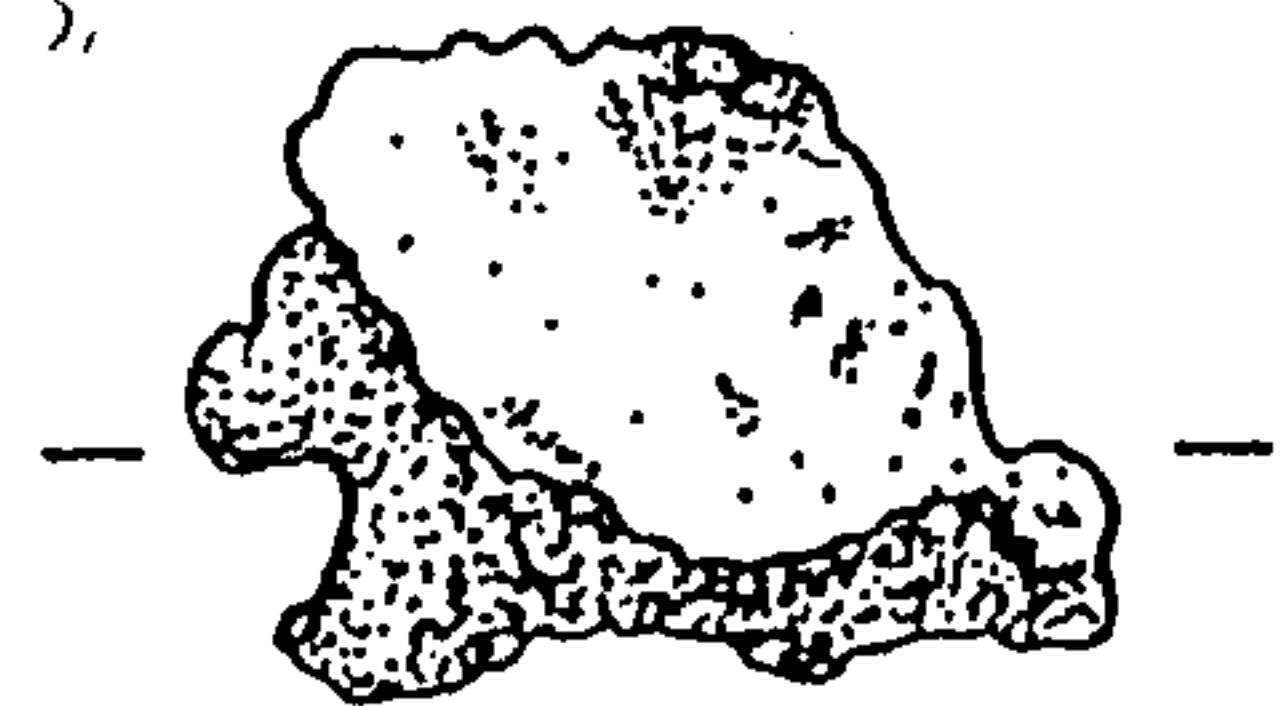


Fig. 85: The Stoke-at-Hoo Hoard (Ref. No. 21): Ingot Metal (iv)

Sturry (Ref. No. 22)

Grid Reference: TR 1667 6037.

Current Location: Canterbury Museum, 7815-7831.

Context: Found in 1942, amongst the roots of a tree in the topsoil of a sandpit.

Bibliography: Grace, R., 1944.
Jessup, R. F., 1930.
N. B. I.

Contents:

22/01 (Acc. No. 7821)

Description: Indented socketed axe.

Dimensions: Length: 94mm. Cutting edge: 39mm.

Patina: Corrosion stripped, details poor.

Manufacture: No traces of the casting seam survive around the mouth, and the metal here appears rough and pitted. Its poor condition is likely to result from recent stripping of the corrosion product, however. Elsewhere, the seam has been virtually obliterated, though it remains noticeable over the collar mouldings.

Use: The cutting edge seems worn and battered, but its original condition is difficult to determine following corrosion removal.

Reduction: The object is complete and there is no evidence relating to this process.

22/02 (Acc. No. 7825)

Description: Indented socketed axe.

Dimensions: Length: 70mm. Cutting edge: 37mm.

Patina: Corrosion stripped, details poor.

Manufacture: The casting seams survive in vestigial form over the entire body, though all traces have been obliterated over the loop.

Use: The stubby appearance of the blade suggests that the object has been resharpened a number of times.

Reduction: The object is complete and there is no evidence relating to this process.

22/03 (Acc. No. 7826)

Description: Indented socketed axe.

Dimensions: Length: 104mm.

Patina: Corrosion stripped, details largely obliterated.

Manufacture: The mouth is very rough and uneven in appearance. A substantial amount of the collar moulding is missing, through an inadequate supply of bronze having been used during casting. The casting seam has been obliterated over the loop, but it remains well-defined and sharp over the remainder of the body, suggesting minimal removal. Fine hammering is apparent at the junction between the blade and the socket, and the cutting edge has been expanded.

Use: It is impossible to identify any details due to corrosion buildup, though the cracking around the mouth may be use-related damage.

Reduction: The cracking noted above may have been caused during the separation of axehead and haft, but use-related damage seems more likely.

22/04 (Acc. No. 7827)

Description: Median-winged axe.

Dimensions: Length: 175mm. Cutting edge: 45mm.

Patina: Corrosion stripped, details largely obliterated.

Manufacture: Stumps of the feeders survive on the butt, which indicates that the implement was poorly finished here. Elsewhere the casting seam has been obliterated almost everywhere. Details are difficult to determine on the underside, however, as the surface is in exceptionally poor condition here. There is some evidence of fine hammering between the wings and around the loop.

Use: The blade is broken, with only a small portion of the cutting edge remaining intact.

Reduction: The object is complete and there is no evidence relating to this process.

22/05 (Acc. No. 7828)

Description: Median-winged axe.

Dimensions: Length: 180mm. Cutting edge: 46mm.

Patina: Rough mid-green, pitted over its extent.

Manufacture: The butt appears very rough and has been poorly finished, with the feeders having been roughly trimmed and hammered, though they remain visible. Elsewhere, over the body, the casting seams have been completely obliterated. The cutting edge has been expanded.

Use: The blade is in a very poor condition, with none of the original cutting edge surviving. Large notches are missing along its extent, too. However, it is difficult to establish when this damage might have taken place following the corrosion removal.

Reduction: The object is complete and there is no evidence relating to this process.

22/06 (Acc. No. 7829)

Description: Median-winged axe.

Dimensions: Length: 166mm. Cutting edge: 39mm.

Patina: Corrosion stripped, piece rough and messy in appearance with no details surviving.

Manufacture: Stumps of the feeder remain visible at the butt, and the object appears poorly finished here. Over the body, however, the casting seams have been obliterated. Some traces of the seam may remain on the lower surface, but corrosion removal has left the piece in a particularly poor condition here, so the details are difficult to ascertain.

Use: The blade is broken, with only a small portion of the cutting edge remaining intact.

Reduction: The object is complete and there is no evidence relating to this process.

22/07 (Acc. No. 7830)

Description: End-winged axe. The edges of the wings have a lipped appearance near the butt.

Dimensions: Length: 145mm. Cutting edge: 42mm.

Patina: Corrosion stripped, details obliterated.

Manufacture: The butt appears uneven, but has been well-finished. Elsewhere, over the body, the casting seam survives as a slight, though prominent, ridge over the upper surface of the piece. The cutting edge has been expanded.

Use: It is difficult to assess the condition of the blade due to the corrosion removal, but it seems blunt though relatively undamaged. The broken loop may be use-related damage.

Reduction: No evidence can be clearly linked with this process.

22/08 (Acc. No. 7826)

Description: Narrow-bladed looped palstave.

Dimensions: Length: 157mm. Cutting edge: 36mm.

Patina: Corrosion stripped, details obliterated.

Manufacture: The casting seam remains visible between the stumps of the loop, though it appears to have been completely removed elsewhere. The blade has been expanded.

Use: The blade seems to have been unevenly worn, but the condition of the cutting edge is difficult to determine. It appears battered, but its poor condition may have been exaggerated following corrosion removal. The broken loop may be use-related damage.

Reduction: There is no evidence which can be clearly linked with this process.

22/09 (Acc. No. 7920)

Description: Socketed gouge, with two collar mouldings present, and an unusual conical boss apparent over the blade.

Dimensions: Length: 120mm.

Patina: Thick olive green, with much thick encrustation present. Details poor.

Manufacture: Dips in the mouth appear to indicate minor casting defects. On one side, the line of the casting seam is represented by a faint step in the section on one side of the body, while on the other it survives as a vestigial trace over its extent.

Use: The blade is now covered by a thick build-up of encrustation, which obscures all evidence relating to the object's use.

Reduction: The object is complete and there is no evidence relating to this process.

22/10 (Acc. No. 7822)

Description: Fragment of single-edged knife or sickle blade. The piece is faintly curved over its extent.

Dimensions: Length (maximum): 55mm.

Patina: Thick light green, with some encrustation present. Details obliterated.

Manufacture: No evidence can be linked with this process.

Use: The edge is battered and notched along its length, but any damage which occurred in antiquity may have been exaggerated through corrosion buildup.

Reduction: No evidence can be associated with this process. There are no hammer indents present in association with either break, and the profile of the fragment is straight, with no distortion evident.

22/11 (Acc. No. 7817)

Description: Leaf-shaped socketed spearhead. One rivet hole survives.

Dimensions: Length (maximum): 148mm.

Patina: Rough light-green, with much encrustation.

Manufacture: No evidence relating to this process can be identified.

Use: On one side of the blade, the cutting edge remains fine and sharp over much of its extent. On the other it is blunt along its length and badly damaged in places, with hardly any of the original cutting edge surviving. Its poor condition may be at least partly attributable to recent damage, however, as fresh metal is revealed. The piece may, however, have been subject to considerable use, as the one surviving rivet hole appears elongated and strained.

Reduction: Part of the socket is now missing. This damage could have been sustained through use, but alternatively, it may have resulted during the separation of spearhead and shaft. Due to corrosion buildup, it is impossible to determine which is the more likely possibility.

22/12 (Acc. No. 7816)

Description: Leaf-shaped socketed spearhead, with two rivet holes present in the socket.

Dimensions: Length (maximum): 191mm.

Patina: Corrosion stripped, details gone.

Manufacture: No traces of any casting seams survive over the extent of the piece. A faint bevel runs down the length of either blade edge.

Use: Both cutting edges are very badly battered over their extent. This damage may be use-related, though it is possible that it was inflicted deliberately.

Reduction: The base of the socket is now missing, damage which may have occurred during the removal of the shaft. Deliberate breakage of the socket cannot be ruled out, either, though it is impossible to identify any specific evidence, i.e. hammer indents, which would support such a possibility.

22/13 (Acc. No. 7815)

Description: Leaf-shaped socketed spearhead, with one rivet hole surviving in vestigial form.

Dimensions: Length (maximum): 241mm.

Patina: The patina is mostly a thick and rather glossy grey-green. There are some rough patches present and some patches of thicker encrustation. Details are locally good.

Manufacture: Some vertical grinding marks run between the blade and the midrib. There are no traces of any casting seams surviving.

Use: The cutting edge is good in most places, but appears more battered near the tip. Corrosion buildup has obscured the edges to some extent, though, making it difficult to assess their condition accurately. The one surviving rivet hole has been torn, and this may indicate use-related damage.

Reduction: The base of the socket has broken away. This damage may be use-related (see above), though deliberate destruction cannot be ruled out. No evidence can be isolated

which would support this latter possibility, though it is possible that any hammer indents associated with the break will have been obscured following corrosion buildup.

22/14 (Acc. No. 7818)

Description: Blade tip from leaf-shaped socketed spearhead.

Dimensions: Length (maximum): 88mm.

Patina: Dense mid-green, with some encrustation. Details poor.

Manufacture: A faint bevel runs down the length of either cutting edge, but no other evidence relating to this process can be identified.

Use: The cutting edges are blunt and rough, but their poor condition may result at least in part from corrosion buildup.

Reduction: The metal is cracked near the break on one side (illustrated), but no hammer indents can be seen in association with this.

22/15 (Acc. No. 7819)

Description: Fragment of spearhead socket, with one rivet hole remaining intact, and a portion of the blade surviving in vestigial form.

Dimensions: Length (maximum): 34mm.

Patina: Rough light-green, details poor.

Manufacture: The casting seams have been obliterated over what survives of the piece.

Use: Impossible to determine.

Reduction: There is a possible hammer indent adjacent to the rivet hole, but this must be viewed with caution due to the nature of the patina.

22/16 (Acc. No. ?7821)

Description: Fragment of tubular spear-ferrule.

Dimensions: Length (maximum): 88mm.

Patina: Thick dark-green, with some encrustation evident,. Details obscured.

Manufacture: The piece seems to have been well-finished, with no traces of any casting seams surviving.

Use: Impossible to determine.

Reduction: Some possible faint hammer marks can be seen at either break, but no distortion of the section is apparent. This hammering may therefore be related to manufacture.

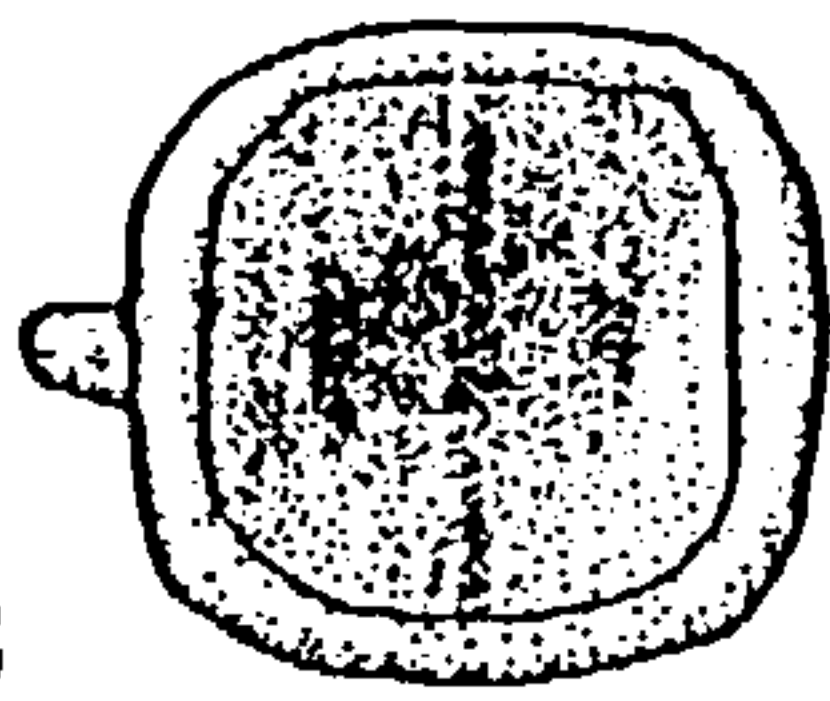
22/17 (Acc. No. 7831)

Description: Large piece of copper ingot.

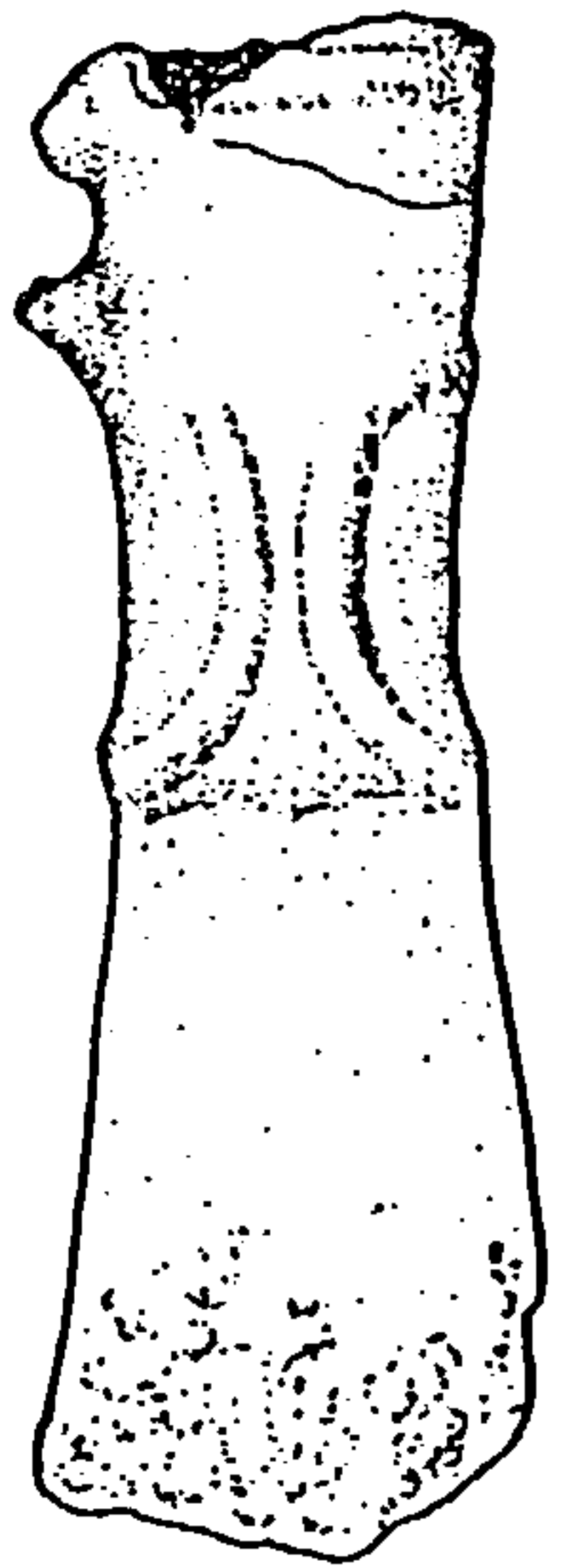
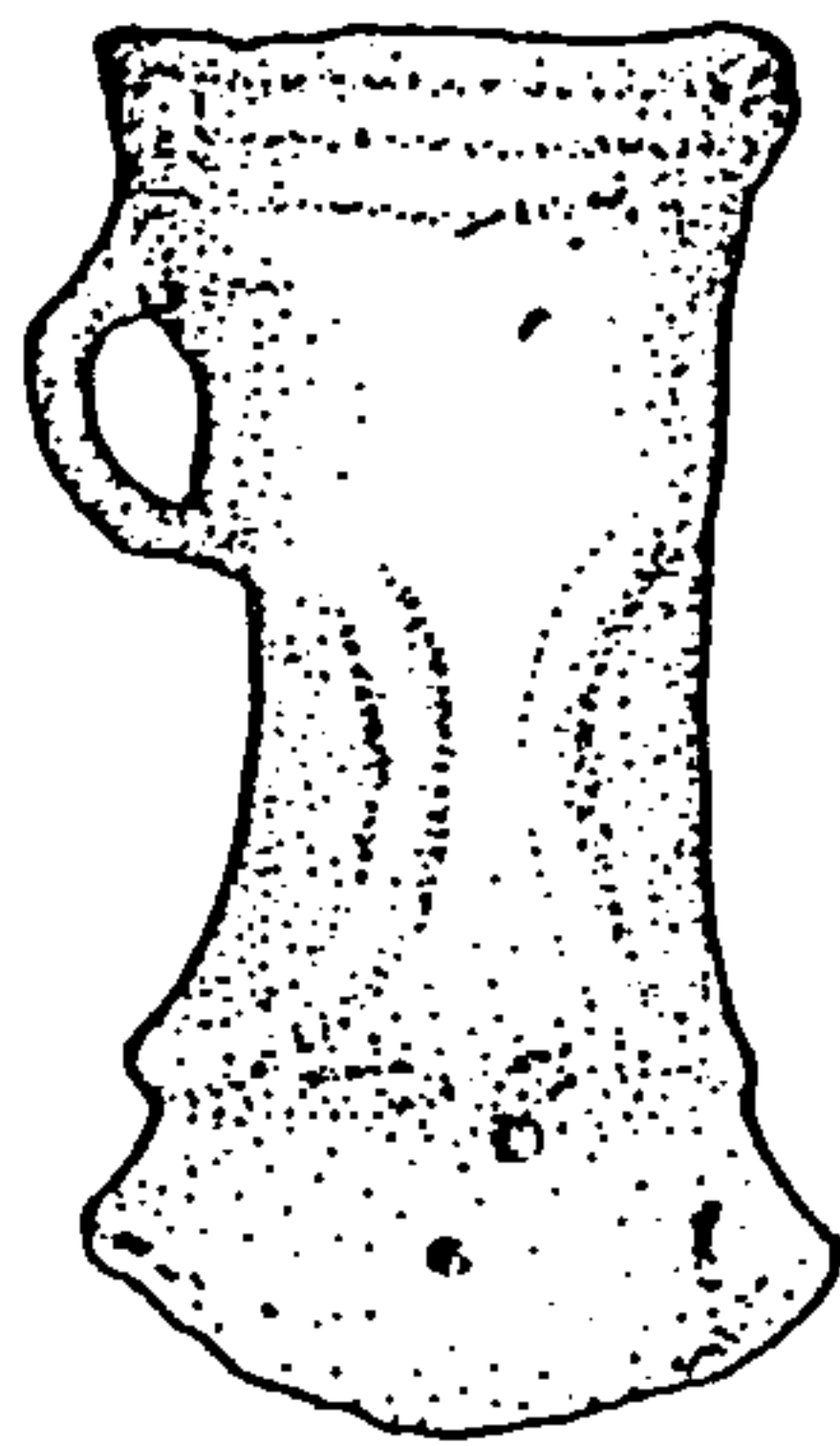
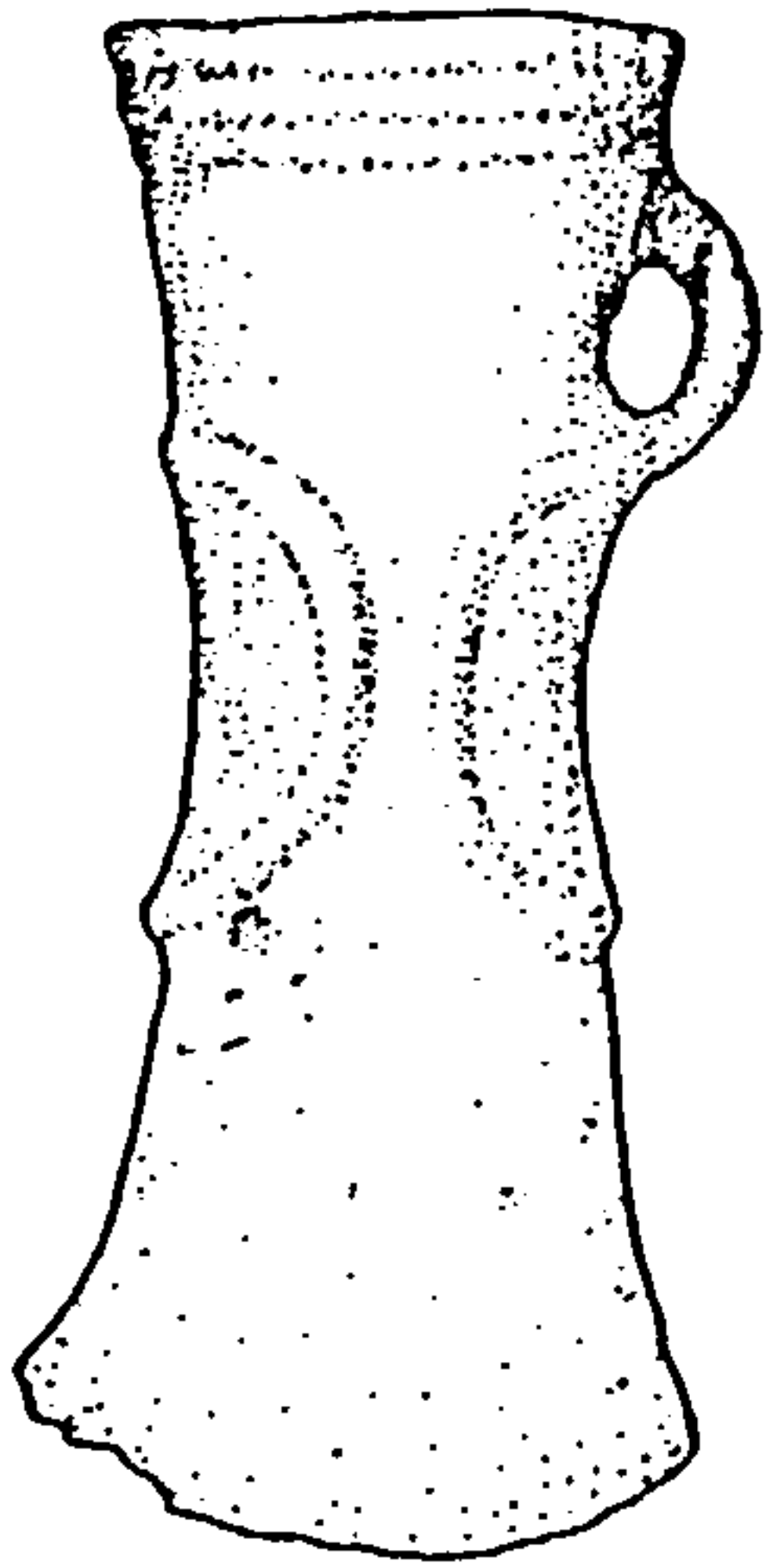
Dimensions: Length: 87mm. Width: 81mm. Thickness: 42mm.

22/01

22/02



22/03



0 2cm

22/04

22/05

22/06

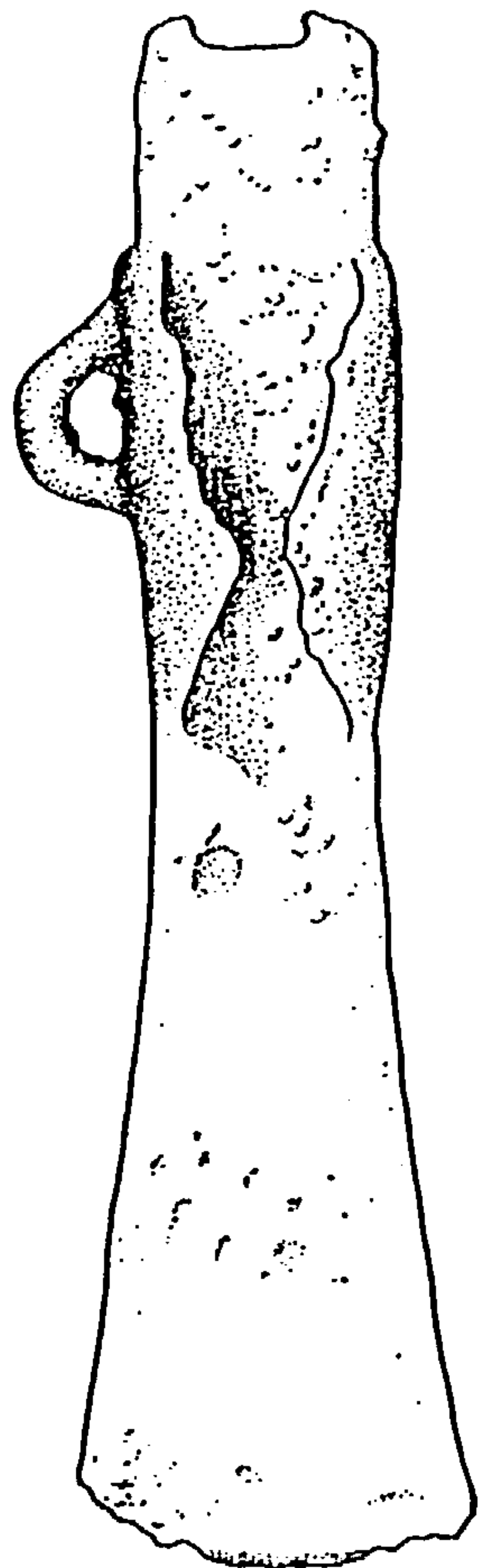
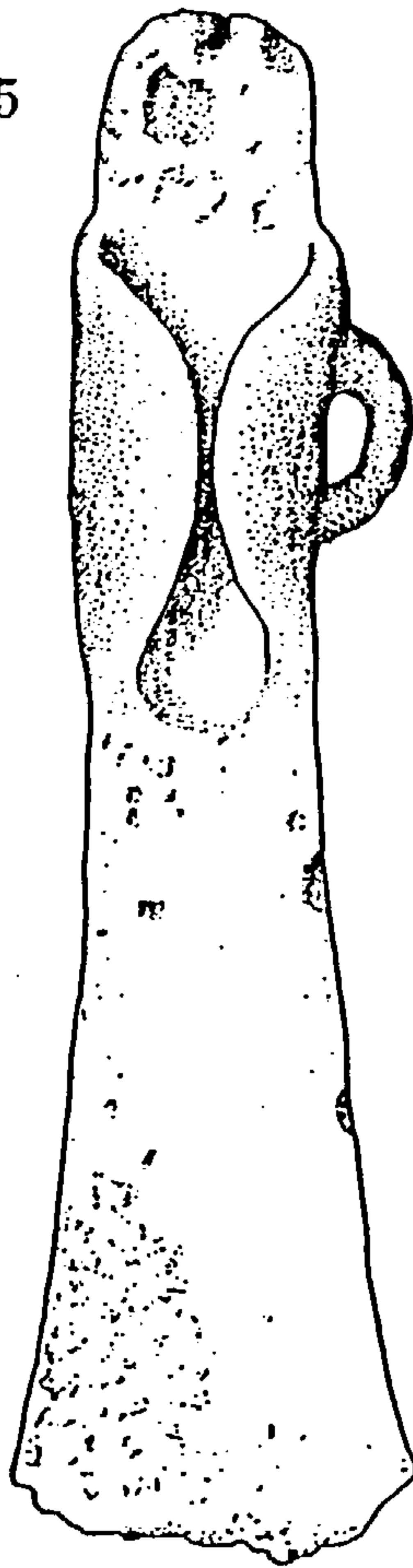
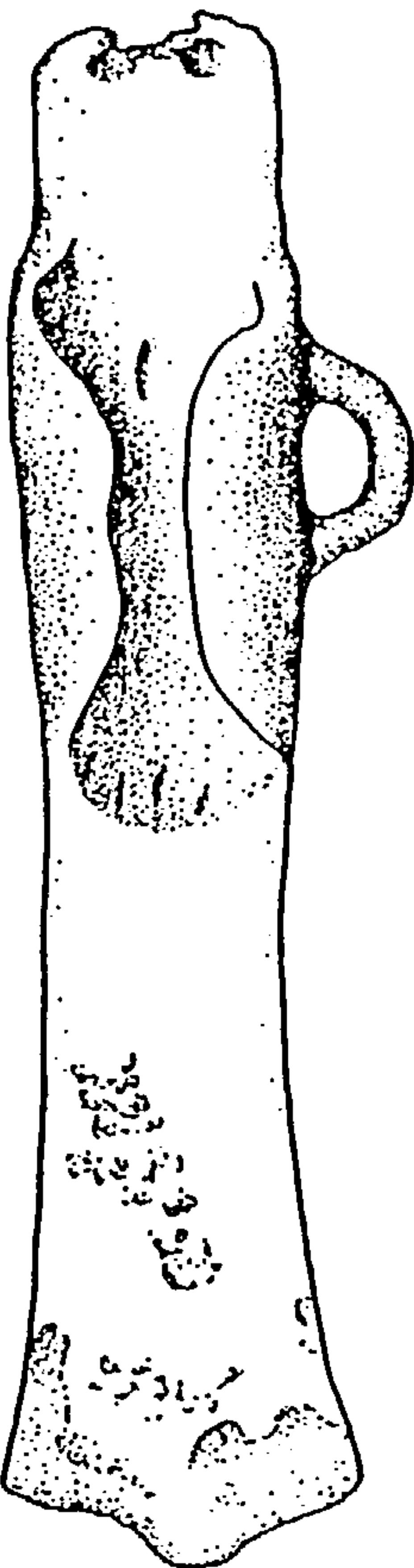
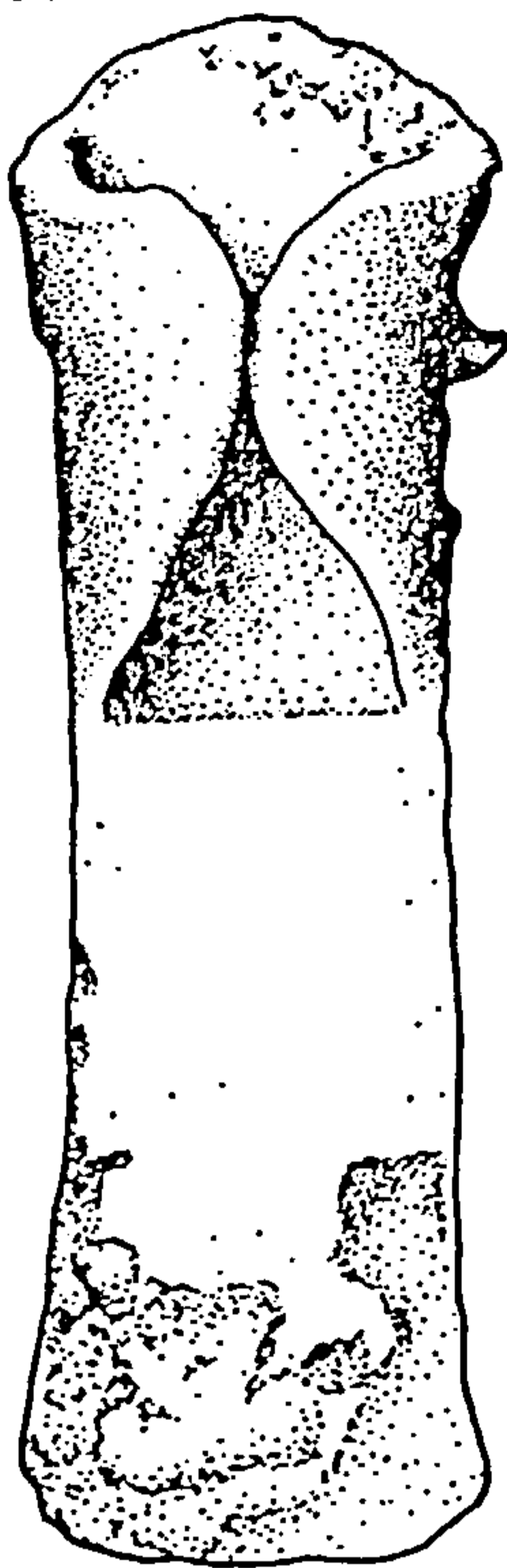
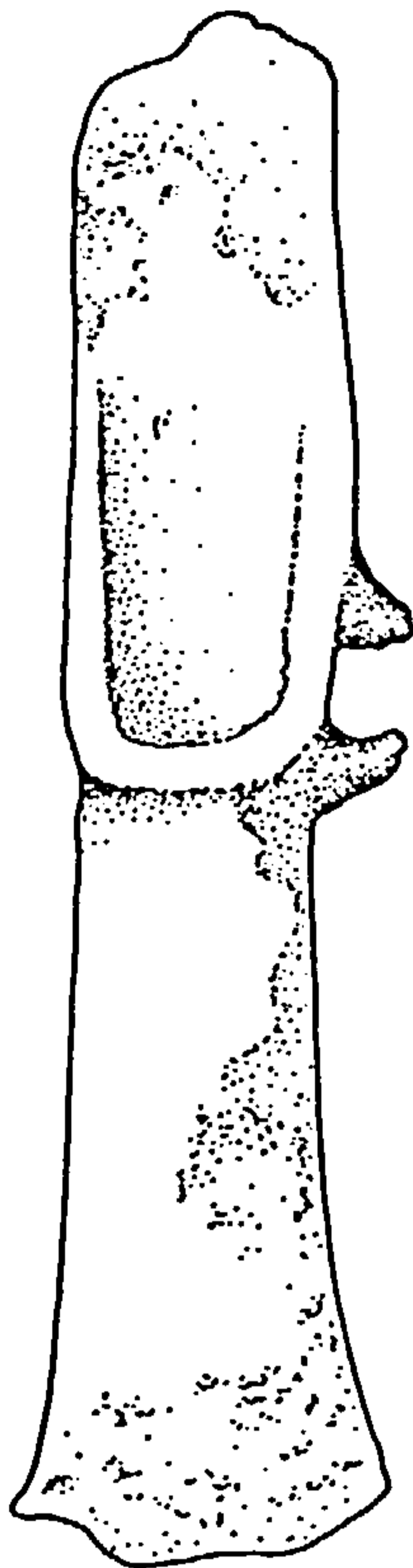


Fig. 86: The Sturry Hoard (Ref. No. 22): Socketed and Winged Axes

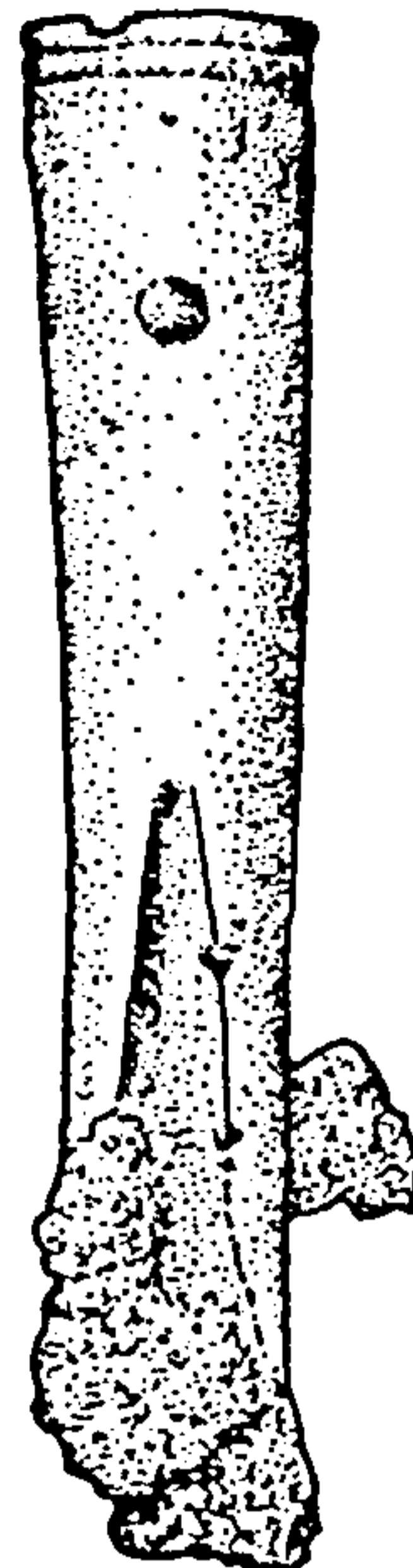
22/07



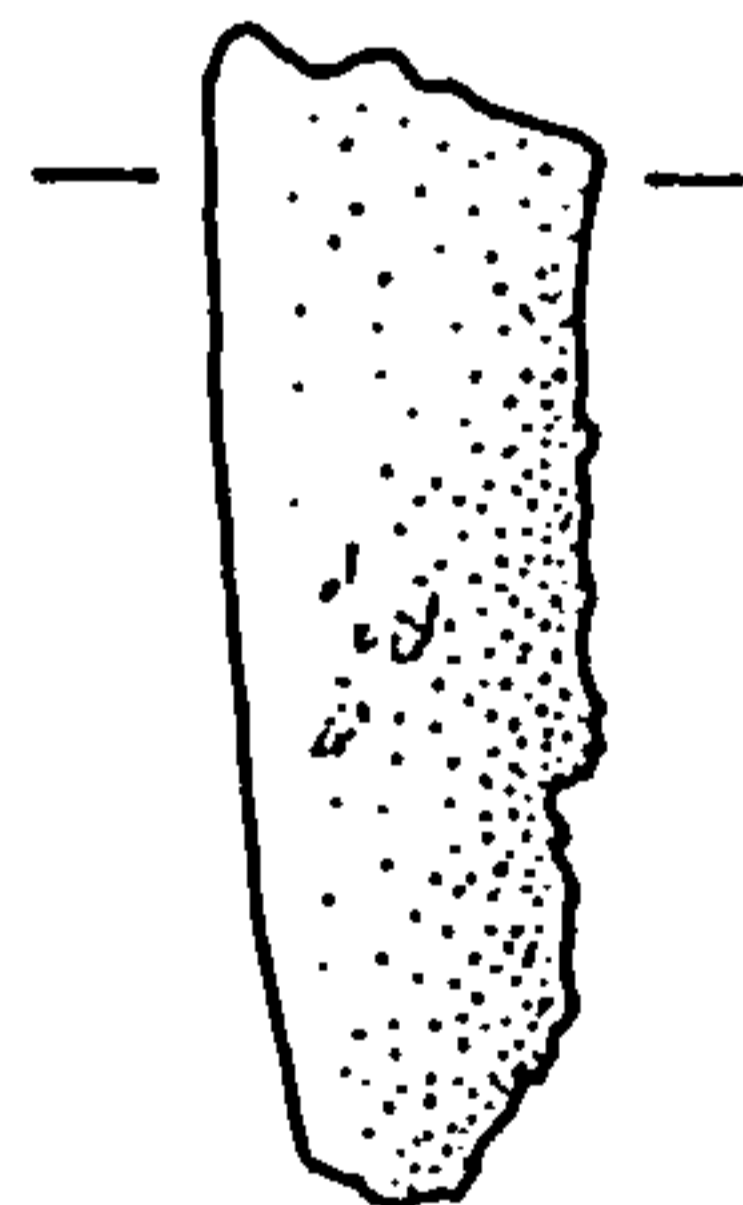
22/08



22/09

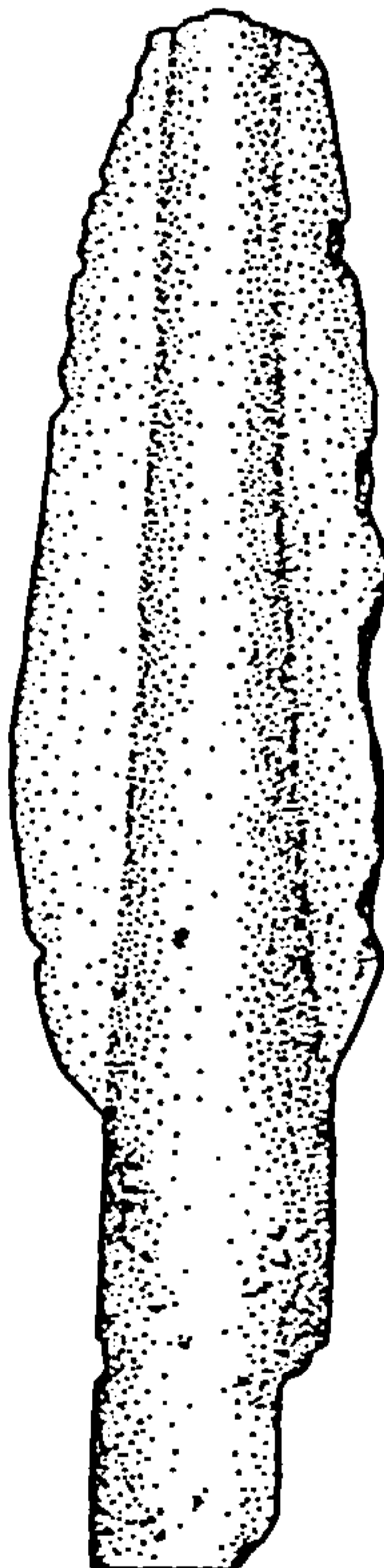


22/10



0 2cm

22/11



22/12

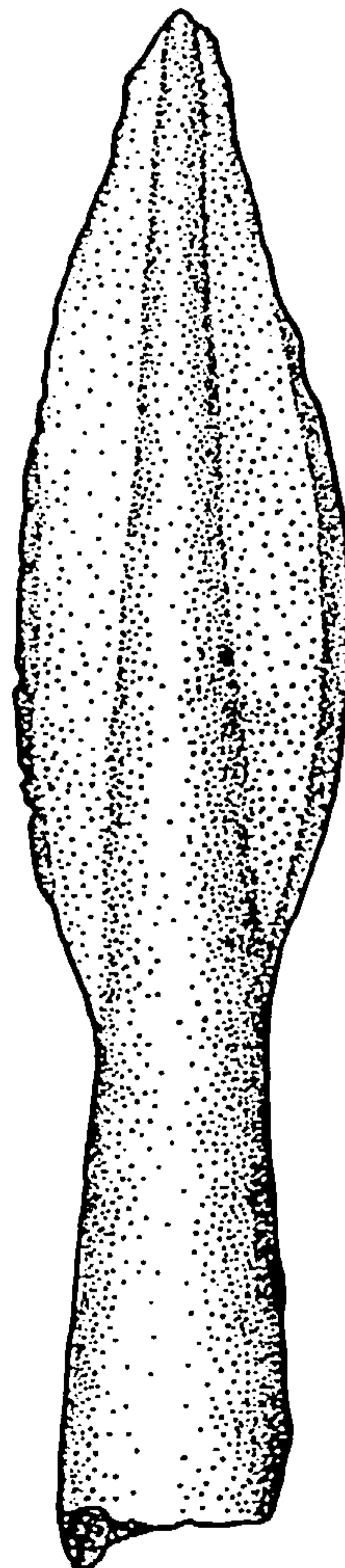
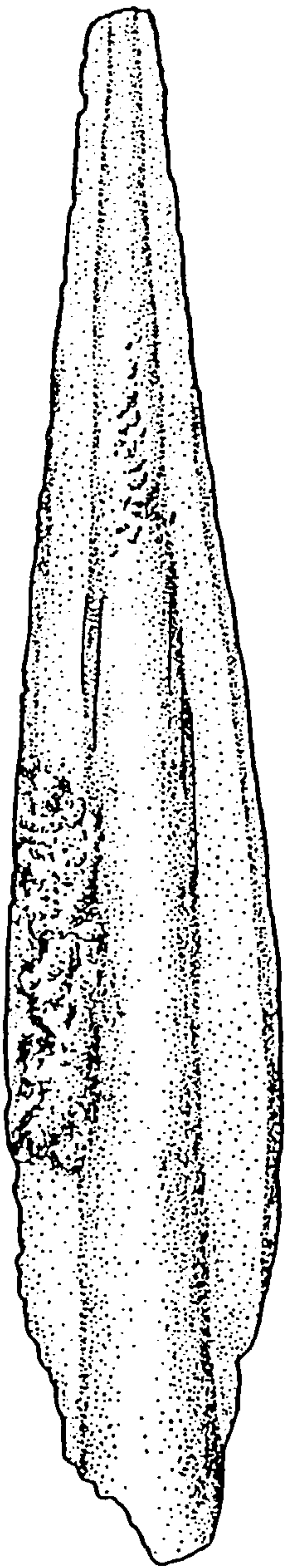
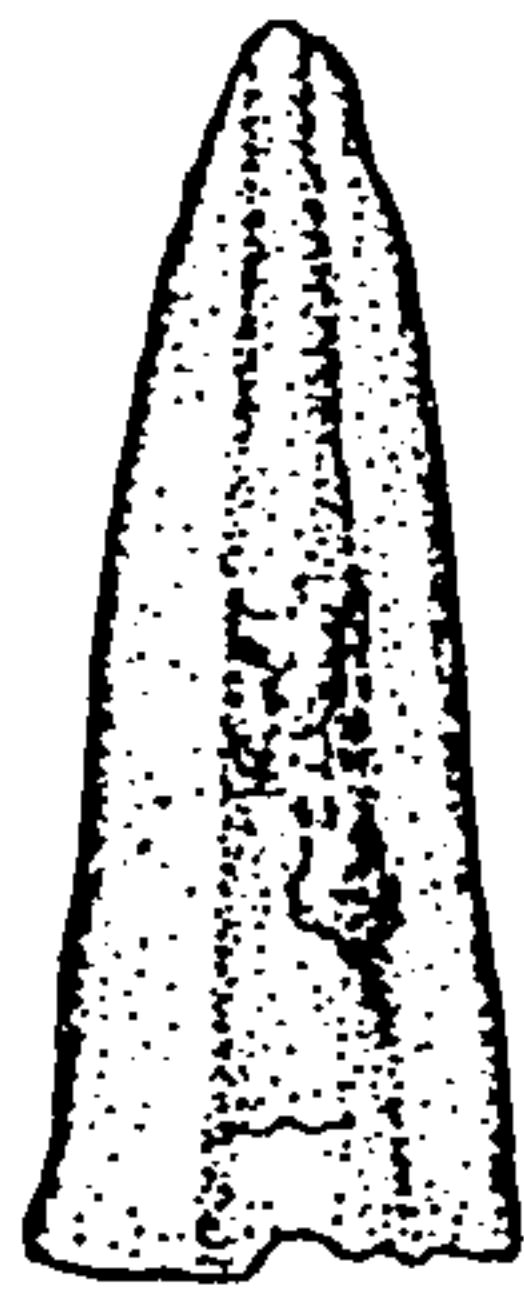


Fig. 87: The Sturry Hoard (Ref. No. 22): Winged Axe, Palstave, Small Tools and Spearheads (i)

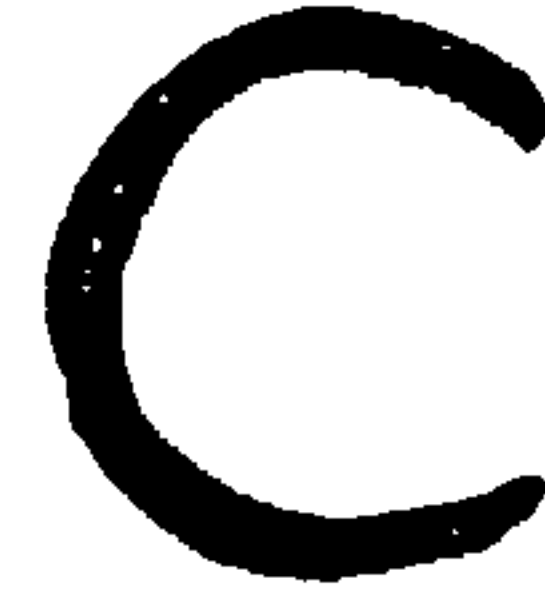
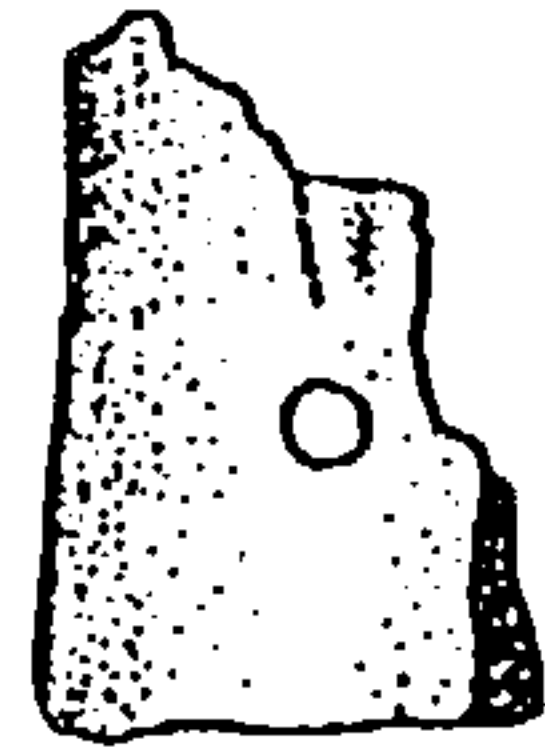
22/13



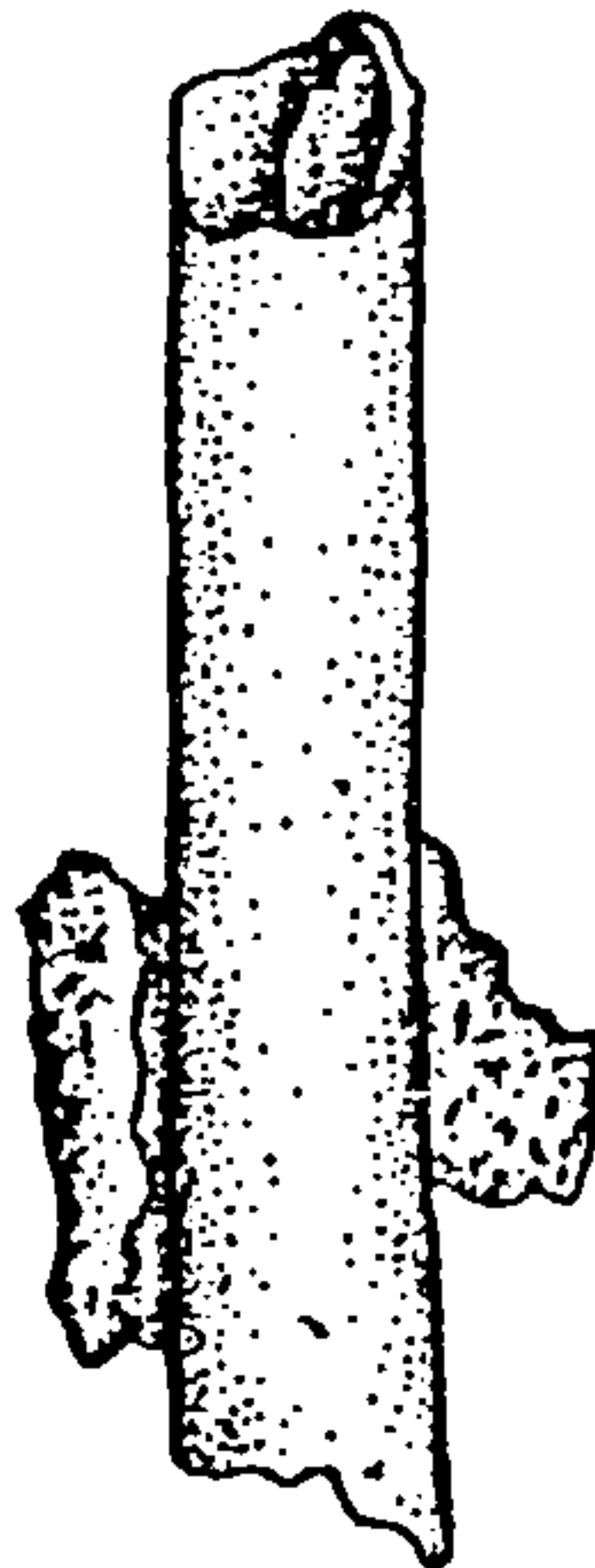
22/14



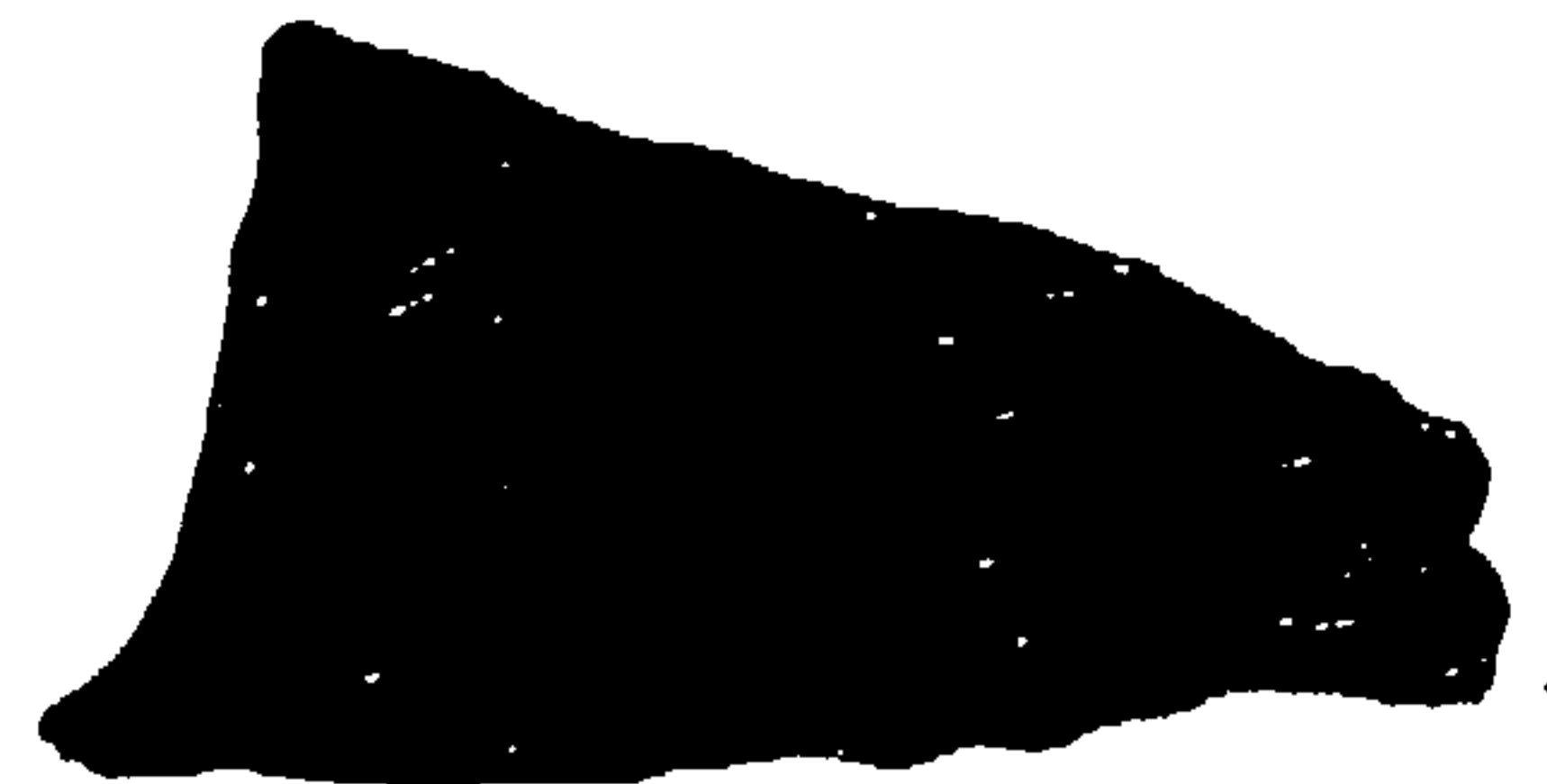
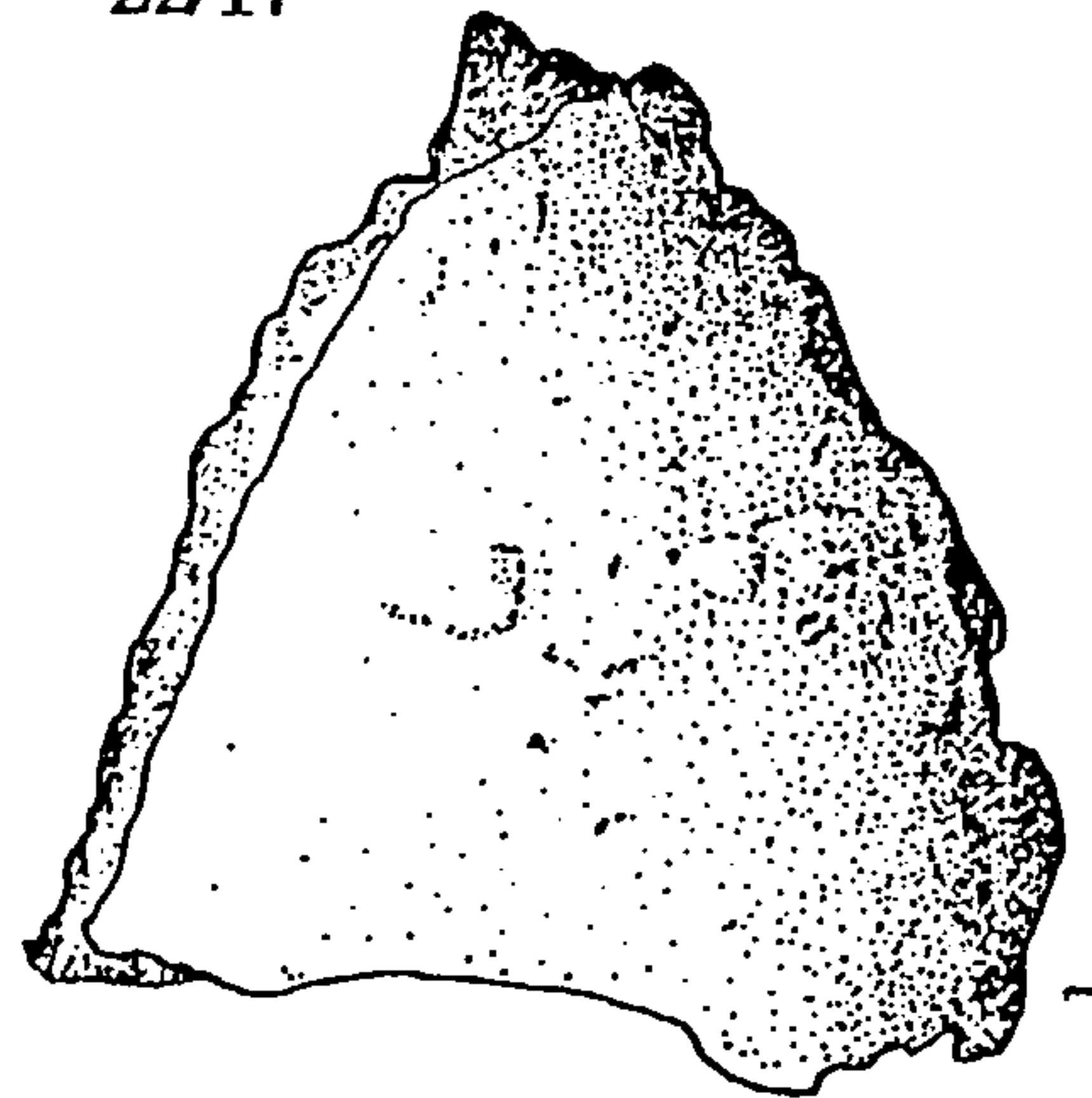
22/15



22/16



22/17



0 2cm

Fig. 88: The Sturry Hoard (Ref. No. 22): Spearheads (ii), Ferrule and Ingot Metal

Whitstable (Swalecliffe) (Ref. No. 23)

Grid Ref.: TR 133 675.

Current Location of Material: British Museum, Acc. Nos. 1922: 2-6: 1-55. A note included with the hoard stated that three objects were missing. With reference to the numbering system, it could be surmised that these comprised two socketed axes, and a fragment of ingot metal.

Context: Revealed during a cliff fall, no further information given.

Bibliography: Burgess and Colquhoun, 1988.
Jessup, 1930.
National Bronze Index.
Worsfold, 1925-7.

Contents:

23/01 (Acc. No. 1922: 2-6: 6)

Description: Socketed axe of 'south-eastern' type. Different variants on the wing-decorated theme are present on either face. On one face (not illustrated) there is a central pellet flanked on either side by a straight wing, or perhaps rib. It may even bear three ribs across its face, the central rib no longer remaining clear through wear or encrustation.

Dimensions: Length: 113mm. Cutting edge: 48mm. Weight: 265.4g.

Patina: Rough mid-green, with much encrustation.

Manufacture: The mouth seems rather rough and uneven, and a slight dip in the collar indicates the presence of a minor casting defect. The feeders have been largely obliterated, though traces of the intervening casting seam survives in places. Over the body, the upper casting seam has been trimmed and polished over its length, but it remains visible to c.30mm from the cutting edge. Below this point, corrosion buildup obscures all detail. The lower seam is still visible over the collar, but has been obliterated over the loop, and is largely invisible from below this point towards the cutting edge. However, corrosion buildup has made the surface very thick and rough here, and the surface is obscured as a result. The cutting edge has been expanded, but remains fairly narrow.

Use: The blade is unevenly worn, and the bevels above either corner of the cutting edge indicate that the piece was subject to resharpener. The cutting edge appears rough and blunt over its length, though corrosion buildup may have adversely affected its appearance.

Reduction: The object is complete, and there is no evidence relating to this process.

23/02 (Acc. No. 1922: 2-6: 10)

Description: Socketed axe of 'south-eastern' type, with a wing-decorated variant present. In this example, the wings are kinked as opposed to the smoothly curved, and the wings are further defined by parallel furrows. Internal ribs are present.

Dimensions: Length: 85mm. Cutting edge: 33mm.

Patina: Rough mid-green. No details evident.

Manufacture: The mouth seems rather uneven, indicating that an inadequate supply of molten metal was poured into the mould during casting. There are, in addition, two very small holes evident which represent minor casting defects. One is located on the lower portion of one face (illustrated), while the other is situated on the underside of the object. Vestigial traces of the casting seam survive around the mouth, though the feeders have been removed. The upper seam has been trimmed over the body, but it remains sharp to a point c. 20mm back from the cutting edge, with no indication of smoothing or hammering apparent. The lower seam is similar, though it appears slightly smoother than the upper example, and it remains *in situ* over the loop. The cutting edge is very narrow, but it appears to have been expanded.

Use: Though the cutting edge is narrow, it has been unevenly worn, which indicates that it has seen some use. It seems blunt but is largely undamaged, though it is chipped in places. Its poor condition may be due at least in part to corrosion buildup and subsequent flaking.

Reduction: The object is complete and there is no evidence relating to this process.

23/03 (Acc. No. 1922: 2-6: 8)

Description: Socketed axe, of wing-decorated 'south-eastern' type. Two internal ribs are present.

Dimensions: Length: 92mm. Cutting edge: 41mm. Weight: 204.9g.

Patina: Rough mid-green, details obscured through encrustation.

Manufacture: Though traces of the casting seam survives around the mouth, these have been flattened and the object appears largely well-finished here. The upper seam is still visible in vestigial form over the body, and appears to have been trimmed and flattened along its length. It has been obliterated over the final 10mm towards the cutting edge. The lower seam has been removed over the loop, but a thin trace is still apparent over the collar and just below the loop. Towards the cutting edge on this side, the surface is obscured by encrustation. The cutting edge has been expanded.

Use: The cutting edge is unevenly worn. It is burred in places, and one corner has broken away.

Reduction: The object is complete and there is no evidence relating to this process.

23/04 (Acc. No. 1922: 2-6: 11)

Description: Socketed axe, of wing-decorated 'south-eastern' type. Internal ribs are present.

Dimensions: Length: 77mm. Cutting edge: 34mm. Weight: 112.0g.

Patina: Rough dark-green, details obliterated.

Manufacture: The mouth appears well-finished. There are no indications of any casting seam over the loop, but elsewhere it is difficult to assess their condition because of the corrosion buildup. The cutting edge is narrow, but it has been expanded.

Use: The blade is unevenly worn, and has probably been resharpened, as hollows are apparent over either corner of the cutting edge. However, the condition of the cutting edge cannot be identified as corrosion products obscure much detail.

Reduction: The object is complete and there is no evidence relating to this process.

23/05 (Acc. No. 1922: 2-6: 4)

Description: Socketed axe, of 'south-eastern' type, decorated with a double-pellet-and-wing motif.

Dimensions: Length: 100mm. Cutting edge: 48mm. Weight: 213.1g.

Patina: Rough dark-green, largely covered with encrustation. Details very poor.

Manufacture: The mouth seems rough and uneven in appearance. The feeders and their intervening seam have largely been removed from around the mouth, with only vestigial traces remaining. Over the length of the body, the upper seam has been trimmed but it still seems sharp. It may have been obliterated over the last 10mm back from the cutting edge, but corrosion buildup makes this hard to determine. The lower seam, by contrast, appears to have been poorly finished. Here, the stump of a chaplet still survives, and the casting seam can still be seen over the loop. Though trimming has been minimal, it appears to have been flattened and smoothed, especially over the collar mouldings and the loop, but over the lower body it seems only to have received minimal finishing. The cutting edge is well expanded.

Use: Hollows over either corner of the cutting edge suggest that the object has been resharpened. The cutting edge is now broken and uneven over its length.

Reduction: Numerous chisel marks on the upper collar were probably inflicted during the process of separating axehead and haft.

23/06 (Acc. No. 1922; 2-6: 5)

Description: Socketed axe, of plain 'south-eastern' type. Two ribs are present in the interior.

Dimensions: Length: 90mm. Cutting edge: 41mm. Weight: 188.1g.

Patina: Thick grey-green, with some rough patches. Details are locally reasonable, though in some places, the outer surface has flaked away.

Manufacture: The mouth has been neatly finished, though some vestigial traces of the seam survive in places. Over the body, the upper seam is well-trimmed and flattened, and has been obliterated to a point measuring c.20mm back from the cutting edge. From here to the cutting edge, however, the surface is much obscured by corrosion buildup. The

condition of the lower seam is more difficult to determine on account of the patina. It has been removed over the loop, but it remains visible over the collar mouldings, and from the loop to a point c.20mm from the cutting edge. It again becomes obscured by the corrosion products from here to the cutting edge. There are traces of vertical grinding marks evident on the upper body, and horizontal grinding marks can be identified over the cutting edge. The blade is narrow in appearance, but it has been expanded.

Use: The cutting edge appears to have been resharpened, with bevels apparent over either corner of the blade. It is still in a reasonable condition, with no large notches present. In places, though, damage has occurred through flaking corrosion products, and thus the original condition of the edge must remain uncertain.

Reduction: There are some rough hammer indents on the upper collar moulding. Such damage might have been inflicted while trying to loosen an axehead which was tightly wedged in place upon its haft.

23/07 (Acc. No. 1922: 2-6: 9)

Description: Socketed axe of 'south-eastern' type, with a possible pellet decoration on one face. Two internal ribs are present.

Dimensions: Length: 84mm. Width: 36mm. Weight: 173.2g.

Patina: Rough dark-green, with much encrustation present. Details obscured.

Manufacture: The mouth appears uneven, with one feeder stump and traces of the accompanying seam surviving. Over the body, the upper seam remains evident right down to the cutting edge. It is very thick over its extent and has a blunt, rounded appearance, suggesting that little if any finishing took place here. The lower seam is thick and poorly trimmed, even over the loop, though between the loop and the cutting edge it appears to have been obliterated. The blade is narrow in appearance, but it has been expanded.

Use: The edge shows some indications of uneven wear, but is otherwise in good condition. **Reduction:** The object is complete and there is no evidence relating to this process.

23/08 (Acc. No. 1922: 2-6: 14)

Description: Lower body and cutting edge of socketed axe, possibly of 'south-eastern' type. There are internal ribs present.

Dimensions: Length (maximum): 78mm. Cutting edge: 42mm. Weight: 125.0g.

Patina: Rough grey-green, details obscured.

Manufacture: Where breakage appears more severe, the section of the wall seems slightly thin, indicating core misalignment. The uppermost seam remains visible as a vestigial trace over the upper body, but has been largely obliterated over the final c.30mm towards the blade. Faint traces of the lower seam can be identified to a point measuring c.20mm back from the edge. The blade has been well expanded, and is virtually crescentic in shape, with bevels apparent over one corner of the cutting edge.

Use: Impossible to determine, as none of the original edge has survived.

Reduction: The mouth and part of the upper body of this axehead are now missing. A hammer indent is associated with the break at the junction between one face and the upper surface (illustrated), and this suggests that breakage might have been deliberately inflicted. The damage to the cutting edge is so severe as to suggest that use-related breakage was unlikely. Instead, deliberate mutilation cannot be excluded.

23/09 (Acc. No. 1922: 2-6: 12)

Description: Mouth and upper body from socketed axe of unknown type. One interior rib is apparent.

Dimensions: Length (maximum): 57mm. Weight: 194.4g.

Patina: Rough grey-green, details obscured.

Manufacture: The object has been well finished around the mouth, with both the feeders and the intervening casting seam removed. The upper casting seam has been roughly trimmed and hammered flat over the length of the fragment, but it remains thick and prominent. By contrast, the lower seam has been virtually obliterated, surviving only at the junction between the loop and the collar.

Use: Impossible to determine.

Reduction: There is no hammering to be seen in association with the break. A fragmentary object has been jammed within the socket of the piece, and it now adheres to the interior following corrosion build-up. It appears to be a thin-sectioned object such as a knife blade, though it could conceivably be a fragment of sheet metal. It seems to have been distorted prior to insertion.

23/10 (Acc. No. 1922: 2-6: 13)

Description: Mouth and upper body of 'south-eastern' type socketed axe, probably undecorated.

Dimensions: Length (maximum): 58mm. Weight: 140.1g.

Patina: Thickly encrusted with mid-green corrosion products. Details poor.

Manufacture: The mouth seems rough and uneven, and one wall is thinner, indicating core misalignment. The upper seam is sharp and prominent, although the corrosion product may have exaggerated its appearance somewhat. The lower seam has been largely obliterated, except over the loop. Here it remains prominent, though it has been flattened to some extent.

Use: Impossible to determine.

Reduction: There are possible hammer indents associated with the break on one face (not illustrated), but these are very faint and cannot be identified with any degree of certainty.

23/11 (Acc No. 1922: 2-6: 18)

Description: Mouth fragment of socketed axe, probably of 'south-eastern' type.

Dimensions: Length (maximum): 24mm. Weight: 49.1g.

Patina: Rough grey-green, details obscured.

Manufacture: The mouth, where it survives, seems fairly uneven, though it has been well-finished. One wall appears to be thinner in section, indicating core misalignment. The condition of the casting seam cannot be established through the corrosion buildup.

Use: Impossible to determine.

Reduction: The section shows distortion at the break. Here, where the face survives, it appears to have been subjected to slight crushing, and some possible hammer marks are visible in association with the break.

23/12 (Acc. No. 1922: 2-6: 15)

Description: Lower body and cutting edge of socketed axe.

Dimensions: Length (maximum): 48mm. Cutting edge: 40mm. Weight: 96.0g.

Patina: Rough grey-green, details obscured.

Manufacture: One wall is thinner, indicating core misalignment. A small hole in the casting can be seen on one face (illustrated), and this represents another minor casting defect. The casting seams have been trimmed and flattened over their length on both sides, but they still survive as vestigial traces all the way down to the cutting edge. The cutting edge is narrow in shape, but has been prepared for use, as a fine bevel has been hammered out along its length.

Use: The cutting edge appears blunt over most of its length. This might suggest that it was never subject to use, though evidence of uneven wear does seem to suggest otherwise. It appears to remain in fine condition, though corrosion buildup obscures the edge to some extent.

Reduction: A depression is apparent in association with the break where the wall is thinner, and some individual hammer indents can be identified in its vicinity (illustrated). Evidence of hammering is also evident on the other face, though no distortion has ensued (not illustrated). Some cracking of the metal in the vicinity of the cutting edge could be use-related damage, but it could also indicate that the blade was subject to hammering in order to break or blunt it.

23/13 (Acc. No. 1922: 2-6: 16)

Description: Cutting edge from socketed axe.

Dimensions: Length (maximum): 31mm. Cutting edge: 52mm. Weight: 46.1g.

Patina: Thick grey-green, details gone.

Manufacture: The casting seam is apparent on one side of the piece, remaining quite sharp though it appears to have been trimmed. On the other side, however, it has been obliterated

Manufacture: The casting seam is apparent on one side of the piece, remaining quite sharp though it appears to have been trimmed. On the other side, however, it has been obliterated over the entire length of the fragment. The cutting edge has a crescentic appearance, which suggests that the object was resharpened, and the fine hammering evident at the corners of the blade edge might have been inflicted during this process. A slight bevel can be seen, running along the length of the cutting edge.

Use: The cutting edge is chipped extensively along its length, only remaining intact at either corner.

Reduction: Some rough hammer indents are evident near the break.

23/14 (Acc. No. 1922: 2-6: 17)

Description: Solid-sectioned cutting edge from an axehead, though it cannot be established whether this piece came originally from a socketed axe or a winged axe.

Dimensions: Length (maximum): 28mm. Cutting edge: 32mm. Weight: 54.5g.

Patina: Rough grey-green, details obscured.

Manufacture: Over one side, the casting seam has been obliterated, while on the other vestigial traces remain. The cutting edge is narrow in appearance.

Use: Impossible to determine. The cutting edge no longer survives.

Reduction: The piece appears rough and its surface undulating and uneven. Its distorted appearance seems to have come about as a result of rough hammering over its entire surface. The cutting edge is now missing, and its complete absence seems more likely to have been the result of deliberate removal rather than use-related damage.

23/15 (Acc. No. 1922: 2-6: 1)

Description: Winged axe.

Dimensions: Length: 154mm. Cutting edge: 39mm. Weight: 412.2g.

Patina: Thick dark-green, details obliterated.

Manufacture: The butt seems rather uneven, with some vestigial traces of the feeders surviving. The blade is narrow in shape, but it has been expanded, and the presence of faint hollows on either side of the cutting edge suggests that it may have been resharpened.

Use: One of the lower wings seems rather battered, and this may be use-related damage, as no hammering can be seen in association. The cutting edge is unevenly worn, and is now in poor condition, with little of the original edge surviving, though corrosion buildup makes assessment difficult.

Reduction: The object is complete and there is no evidence which clearly relates to this process.

23/16 (Acc. No. 1922: 2-6: 2)

Description: Butt fragment of winged axe, with grooves running around the wings (see Manufacture below).

Dimensions: Length (maximum): 76mm. Cutting edge: 42mm. Weight: 285.6g.

Patina: Thick mid-green in most places, with details obscured.

Manufacture: No casting seams can be identified, though in places corrosion buildup may have obscured any surviving traces. However, where the patina remains a smooth grey-green, no seam is evident, and this absence suggests that the piece has been well-finished. The piece is unusual in that the wings appear to have decoration running around them. At first, this was dismissed as fortuitous, having resulted from nothing more significant than corrosion buildup around an area where a cord had, for some unknown reason, been wrapped around the wings prior to deposition. However, the grooves were mismatched between the wings, which suggests that they were more likely to have been intended as deliberate decoration, made by wrapping a length of cord around the wax former which was used to create the original mould.

Use: Impossible to determine.

Reduction: The butt is uneven and the section here shows slight distortion, suggesting that hammering was inflicted here. The wings appear to have been hammered inwards towards the body on both sides. Between the wings on one side a stone has been securely wedged, though it is impossible to determine whether this resulted from a deliberate act or from natural processes following deposition, though the stone is very tightly jammed into place.

The stone is itself unusual: a brilliant red colour, with a crazed surface, and it is possible that it is in fact a fragment of some kind of iron ore, though analysis would have to be carried out to confirm this.

23/17 (Acc. No. 1922: 2-6: 20)

Description: Socketed gouge, with a single collar moulding.

Dimensions: Length: 84mm. Weight: 68.4g.

Patina: Rough mid-green, with some bronze showing.

Manufacture: Some slight dips around the collar represent minor casting defects. The casting seams are still apparent in vestigial form on either side, but although they remain quite prominent near the collar, they have been obliterated towards the cutting edge.

Use: The cutting edge is chipped at one side, and this damage appears to have taken place in antiquity.

Reduction: The object is complete and there is no evidence relating to this process.

23/18 (Acc. No. 1922: 2-6: ?21)

Description: Lower body and blade of socketed gouge.

Dimensions: Length (maximum): 52mm. Weight: 38.2g.

Patina: Rough mid-green, details obscured.

Manufacture: No traces of any casting seams are apparent, but corrosion buildup obscures much detail.

Use: There is a notch at one corner of the cutting edge, which seems otherwise good.

Reduction: The section shows distortion at the break, with the rear of the piece having been pushed inwards here. This damage appears to have been caused by one massive hammer blow, though it is possible that it is composed of a series of smaller superimposed indents. There are also some smaller indentations on the front of the piece, and once again a hammer seems likely to have inflicted these.

23/19 (Acc. No. 1922: 2-6: 23)

Description: Lower blade of knife, most likely to have come from a 'Thorndon' type socketed knife. The midrib and blade edges are defined by grooves.

Dimensions: Length (maximum): 88mm. Weight: 45.2g.

Patina: Much of the original bronze colour remains, with some dark-green encrustation occurring. Details locally good.

Manufacture: The cutting edges are finely bevelled, with some grinding marks visible in places.

Use: The cutting edges are badly notched and battered along their length, and where they remain intact, they seem blunt. Altogether, the piece appears to be in poor condition.

Reduction: The profile of the piece is badly distorted, with some small tool marks and heavier hammer indents evident in the places (illustrated).

23/20 (Acc. No. 1922: 2-6: 28)

Description: Blade fragment from an unknown object. It seems likely to be a sword, though its section seems rather thin, and thus the possibility that it is in fact a knife fragment cannot be ruled out.

Dimensions: Length (maximum): 52mm. Weight: 20.1g.

Manufacture: No evidence can be linked with this process.

Use: Impossible to determine, as none of the original edge remains. Much of this damage appears to result from the loss of corrosion products in recent times.

Reduction: No evidence can be linked with this process, due to the poor condition of the piece.

23/21 (Acc. No. 1922: 2-6: 25)

Description: Blade fragment of leaf-shaped sword, probably of 'Ewart Park' type.

Dimensions: Length (maximum): 40mm. Weight: 41.0g.

Patina: Thick and rough grey-green. Details obliterated.

Manufacture: There is no evidence which can be linked with this process.

Use: The blade edges are battered and chipped along their length. Some damage is undoubtedly recent, and has resulted from flaking of the corrosion product, but much seems to have taken place in antiquity.

Reduction: There is a faint bow to the profile of the fragment, but no hammering can be seen in association with either break.

23/22 (Acc. No. 1922: 2-6: 26)

Description: Blade fragment of leaf-shaped sword.

Dimensions: Length (maximum): 43mm. Weight: 42.4g.

Patina: Thick grey-green, coated with much encrustation, details obscured.

Manufacture: No evidence can be linked with this process.

Use: Impossible to determine. The cutting edges are in poor condition, but this may be due in part to the nature of the corrosion product.

Reduction: There is a faint bend to the profile, but no hammer indents can be seen in association with the break, perhaps as a result of corrosion buildup.

23/23 (Acc. No. 1922: 2-6: 22)

Description: Blade tip from 'Carp's Tongue' sword, with some traces of a grooved decoration defining the midrib towards the break.

Dimensions: Length (maximum): 103mm. Weight: 50.3g.

Patina: Rough grey-green, details obliterated.

Manufacture: There are traces of a fine bevel running down either cutting edge, and there is some evidence of fine hammering in the vicinity of the midrib on one side (not illustrated).

Use: The cutting edge remains largely intact, but it is notched and chipped in places, especially near the tip. Some of this damage may have occurred in recent times.

Reduction: There are no indications of hammering, and the profile of the fragment shows no distortion.

23/24 (Acc. No. 1922: 2-6: ?29)

Description: Fragmentary purse chape, comprising roughly half of the original object. The edge of the rim appears to be thickened, but this is hard to determine as a result of corrosion buildup. One rivet hole survives.

Dimensions: Width: 25mm. Weight: 10.6g.

Patina: Rough, grey green patina, details obliterated.

Manufacture: There is no evidence relating to this process.

Use: The metal appears thinner towards the broken edge at the base of the chape, and this may be use-related wear, though it is difficult to establish whether or not this is the case as a result of corrosion buildup.

Reduction: There is no evidence which points to deliberate breakage. At one side, the break is associated with fresh metal, which suggests that it occurred in recent times.

23/25 (Acc. No. 1922: 2-6: 19)

Description: Fragmentary socket from socketed spearhead, with one rivet hole surviving.

Dimensions: Length (maximum): 34mm. Weight: 8.0g.

Patina: Rough grey-green, details poor.

Manufacture: No traces of the casting seams survive.

Use: Impossible to determine.

Reduction: The section is now much distorted, this damage having occurred as a result of hammering. Some isolated hammer indents can be identified in the vicinity of the rivet hole. This damage was probably incurred during the fragmentation process, and probably contributed to the vertical subdivision of the socket.

23/26 (Acc. No. 1922: 2-6: 27)

Description: Blade fragment of socketed spearhead, with a fillet-defined midrib.

Dimensions: Length (maximum): 54mm. Weight: 26.5g.

Patina: Much bronze remains visible, though patches of encrustation have built up in places.

Manufacture: The midrib is filled with what seems likely to be the remnants of the clay core. The wall here seems rather thin, indicating core misalignment.

Use: The cutting edges are much distorted, making it impossible to establish their condition.

Reduction: The piece has been crushed over its extent. It is now badly distorted, with the midrib almost flattened and the blade twisted out of its original alignment.

23/27 (Acc. No. 1922: 2-6: 24)

Description: Blade fragment of socketed spearhead with fillet-defined midrib.

Dimensions: Length (maximum): 39mm. Weight: 33.3g.

Patina: Rough grey-green, with some bronze showing. Details obscured.

Manufacture: The clay core still appears to be in situ. The walls are of uneven thickness, indicating core misalignment.

Use: The cutting edges are battered and notched along their extent, with none of the original edge remaining on one side.

Reduction: The profile is slightly distorted towards the upper break, and some hammer indents are visible in association with the lower break.

23/28 (Acc. No. 1922: 2-6: 30)

Description: Casting jet from unknown object, with two feeders apparent.

Weight: 21.9g.

23/29 (Acc. No. 1922: 2-6: 31)

Description: Large piece from edge of copper ingot.

Dimensions: Length: 60mm. Width: 50mm. Thickness: 35mm. Weight: 388.7g.

23/30 (Acc. No. 1922: 2-6: 32)

Description: Large piece from edge of copper ingot.

Dimensions: Length: 63mm. Width: 59mm. Thickness: 32mm. Weight: 424.7g.

Observations: Recent damage has left notches and striations on the surface of the piece.

23/31 (Acc. No. 1922: 2-6: 33)

Description: Piece from interior of copper ingot.

Dimensions: Length: 77mm. Width: 40mm. Thickness: 30mm. Weight: 353.4g.

23/32 (Acc. No. 1922: 2-6: 34)

Description: Large piece from interior of copper ingot.

Dimensions: Length: 59mm. Width: 55mm. Thickness: 29mm. Weight: 577.0g.

23/33 (Acc. No. 1922: 2-6: 35)

Description: Piece from edge of copper ingot, with a large number of voids present.

Dimensions: Length: 71mm. Width: 46mm. Thickness: 24mm. Weight: 241.6g.

23/34 (Acc. No. 1922: 2-6: 37)

Description: Piece from interior of copper ingot.

Dimensions: Length: 64mm. Width: 50mm. Thickness: 28mm. Weight: 452.6g.

23/35 (Acc. No. 1922: 2-6: 38)

Description: Piece from edge of copper ingot.

Dimensions: Length: 71mm. Width: 54mm. Thickness: 27mm. Weight: 389.5g.

23/36 (Acc. No. 1922: 2-6: 39)

Description: Piece from edge of copper ingot.

Dimensions: Length: 74mm. Width: 57mm. Thickness: 35mm. Weight: 495.6g.

23/37 (Acc. No. 1922: 2-6: 40)

Description: Piece from edge of copper ingot.

Dimensions: Length: 69mm. Width: 54mm. Thickness: 32mm. Weight: 283.2g.

23/38 (Acc. No. 1922: 2-6: 41)

Description: Piece from edge of copper ingot.

Dimensions: Length: 76mm. Width: 39mm. Thickness: 21mm. Weight: 215.9g.

23/39 (Acc. No. 1922: 2-6: 42)

Description: Piece from interior of copper ingot.

Dimensions: Length: 62mm. Width: 41mm. Thickness: 33mm. Weight: 293.3g.

23/40 (Acc. No. 1922: 2-6: 43)

Description: Piece from edge of copper ingot.

Dimensions: Length: 56mm. Width: 52mm. Thickness: 27mm. Weight: 307.5g.

23/41 (Acc. No. 1922: 2-6: ?44)

Description: Small piece from edge of copper ingot, with some voids present in the interior. The accession number is unclear, though the figure '4' is visible. This suggests that the piece is likely to be 1922: 2-6: 44, as no other number seems to be applicable.

Dimensions: Length: 48mm. Width: 42mm. Thickness: 19mm. Weight: 147.5g.

23/42 (Acc. No. 1922: 2-6: 45)

Description: Small piece from edge of copper ingot.

Dimensions: Length: 56mm. Width: 35mm. Thickness: 26mm. Weight: 198.2g.

23/43 (Acc. No. 1922: 2-6: 46)

Description: Small piece from interior of copper ingot.

Dimensions: Length: 47mm. Width: 47mm. Thickness: 26mm. Weight: 189.0g.

23/44 (Acc. No. 1922: 2-6: 47)

Description: Small piece from edge of copper ingot, with large voids present in the interior.

Dimensions: Length: 46mm. Width: 39mm. Thickness: 21mm. Weight: 126.6g.

23/45 (Acc. No. 1922: 2-6: 48)

Description: Fragment from interior of copper ingot.

Dimensions: Length: 47mm. Width: 32mm. Thickness: 30mm. Weight: 128.6g.

23/46 (Acc. No. 1922: 2-6: 49)

Description: Fragment from edge of copper ingot.

Dimensions: Length: 40mm. Width: 34mm. Thickness: 21mm. Weight: 62.6g.

23/47 (Acc. No. 1922: 2-6: 50)

Description: Fragment from interior of copper ingot.

Dimensions: Length: 33mm. Width: 30mm. Thickness: 18mm. Weight: 62.6g.

23/48 (Acc. No. 1922: 2-6: 51)

Description: Fragment from interior of copper ingot.

Dimensions: Length: 37mm. Width: 34mm. Thickness: 105.6g.

23/49 (Acc. No. 1922: 2-6: 52)

Description: Fragment from edge of copper ingot.

Dimensions: Length: 32mm. Width: 26mm. Thickness: 17mm. Weight: 53.7g.

23/50 (Acc. No. 1922: 2-6: 53)

Description: Small piece from edge of copper ingot.

Dimensions: Length: 44mm. Width: 44mm. Thickness: 16mm. Weight: 107.6g.

23/51 (Acc. No. 1922: 2-6: 54)

Description: Small piece from edge of copper ingot.

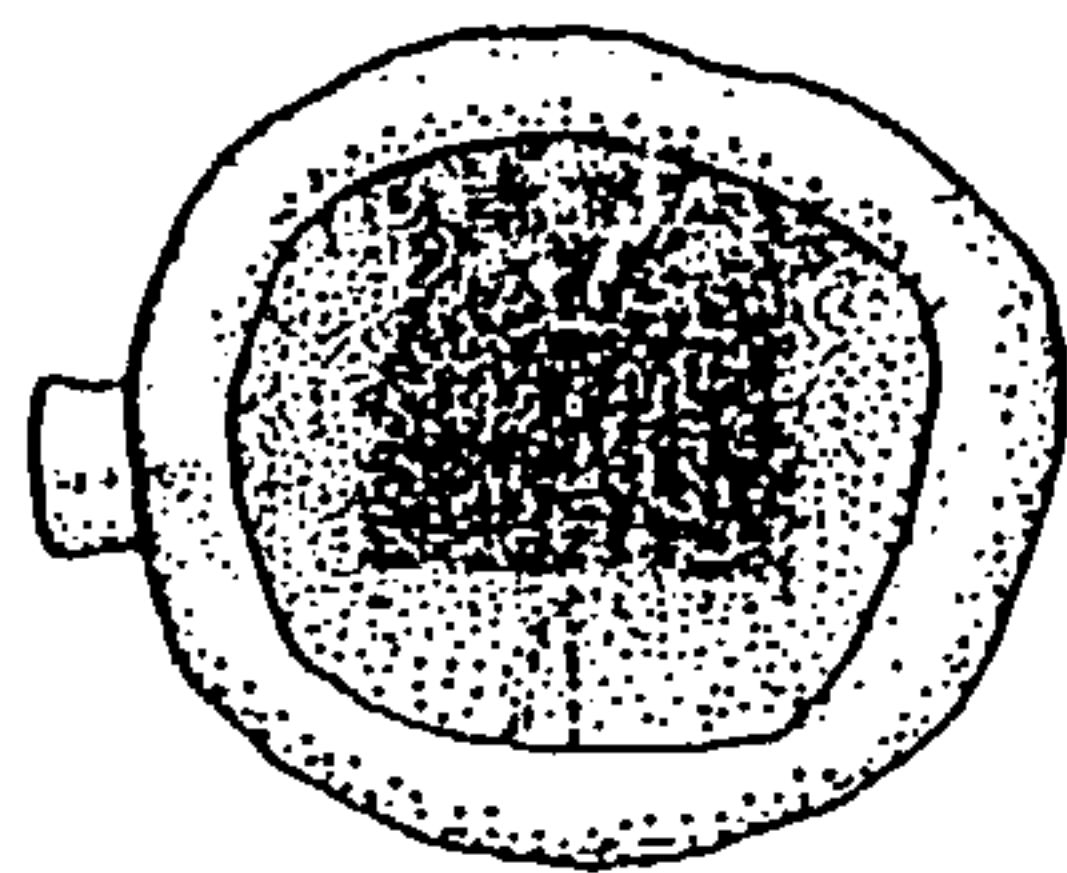
Dimensions: Length: 45mm. Width: 38mm. Thickness: 20mm. Weight: 96.5g.

23/52 (Acc. No. 1922: 2-6: 55)

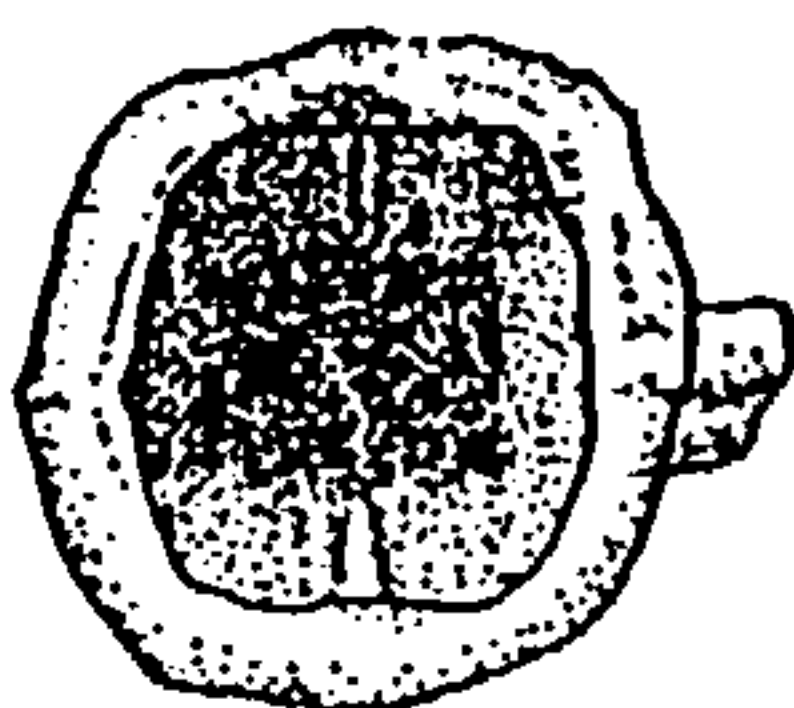
Description: Small fragment from interior of copper ingot.

Dimensions: Length: 24mm. Width: 22mm. Thickness: 29mm. Weight: 60.7g.

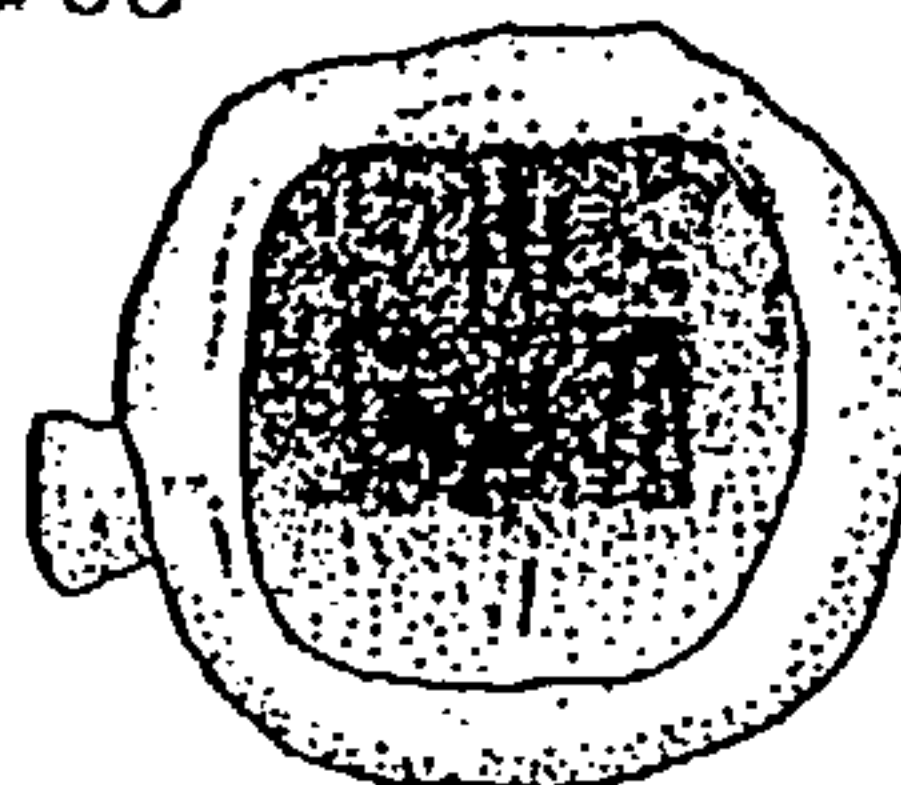
23/01



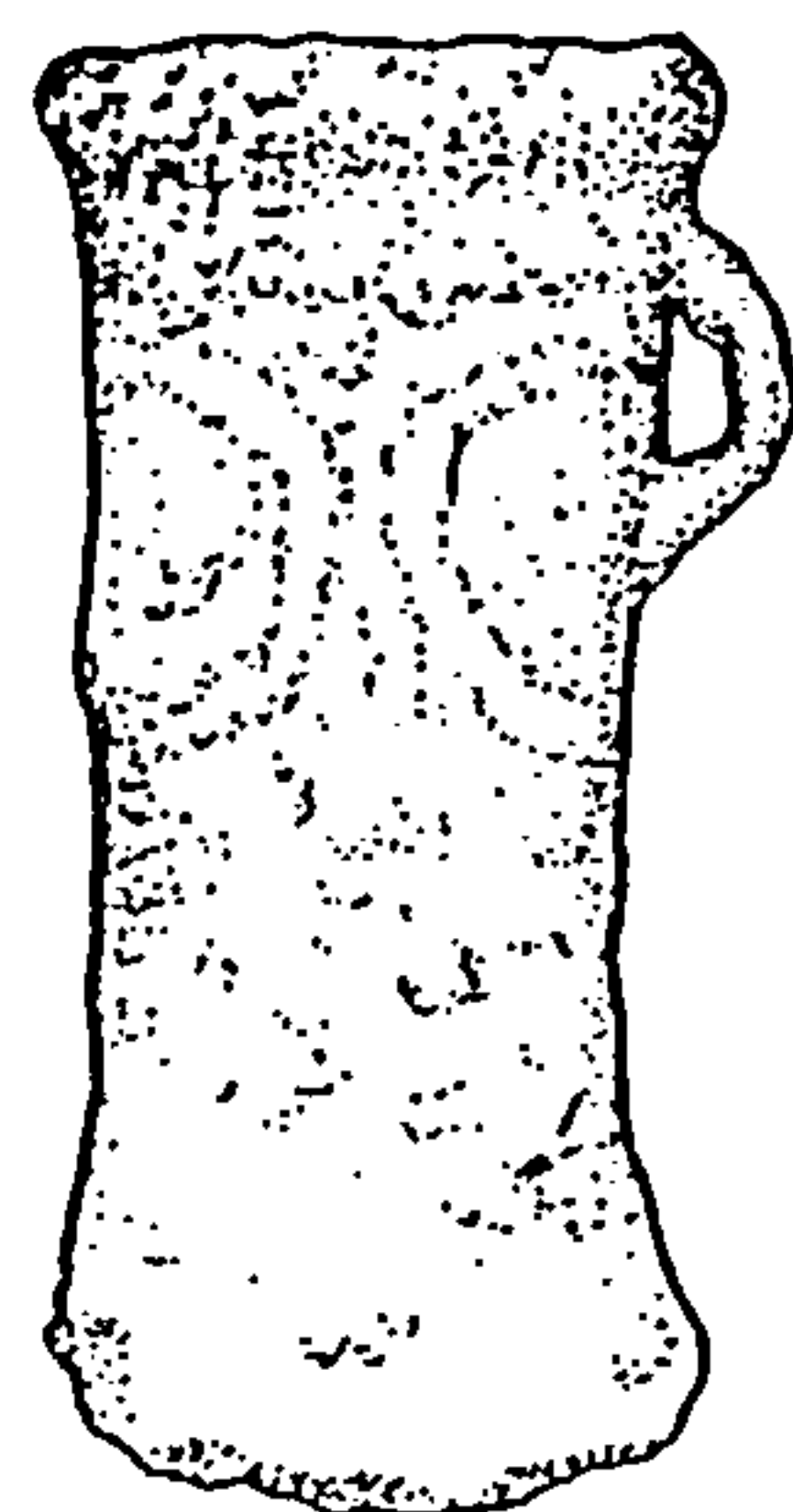
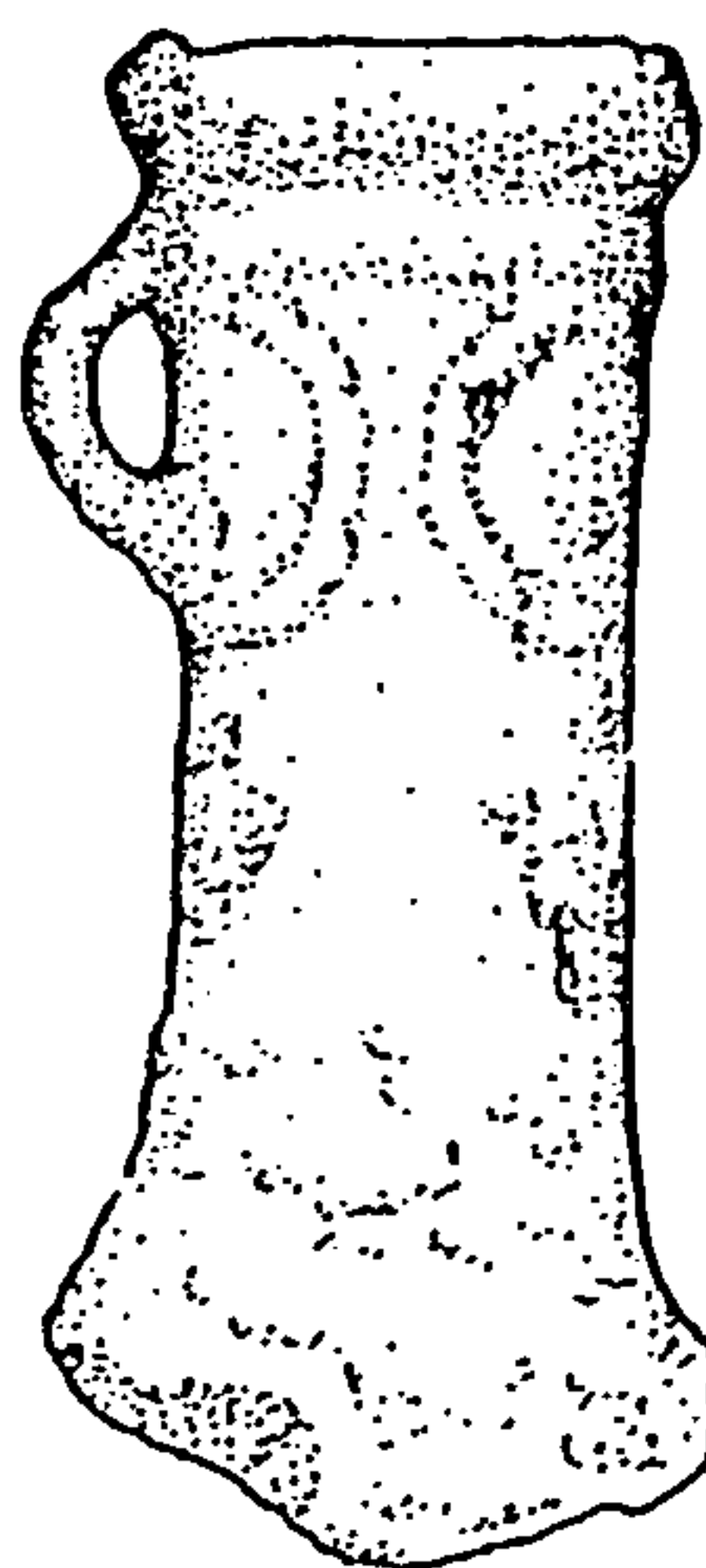
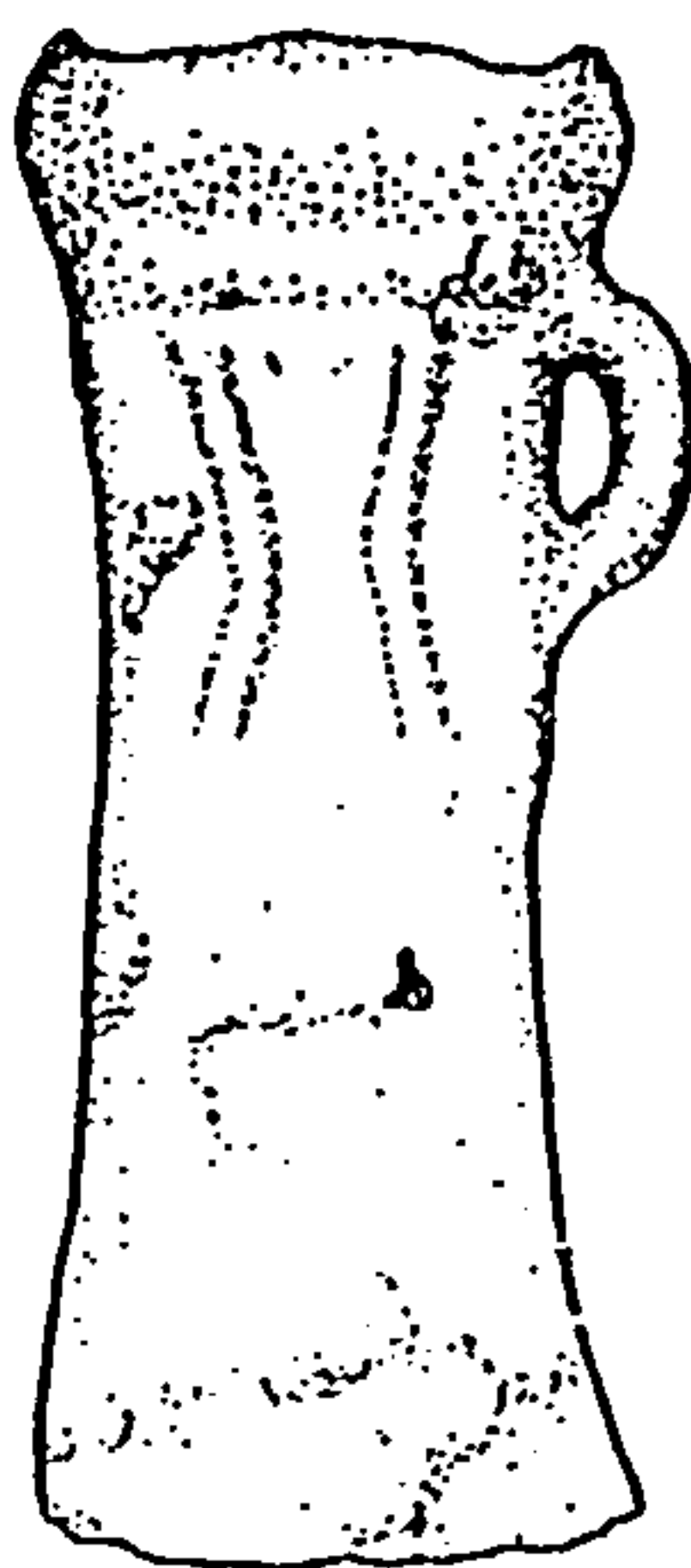
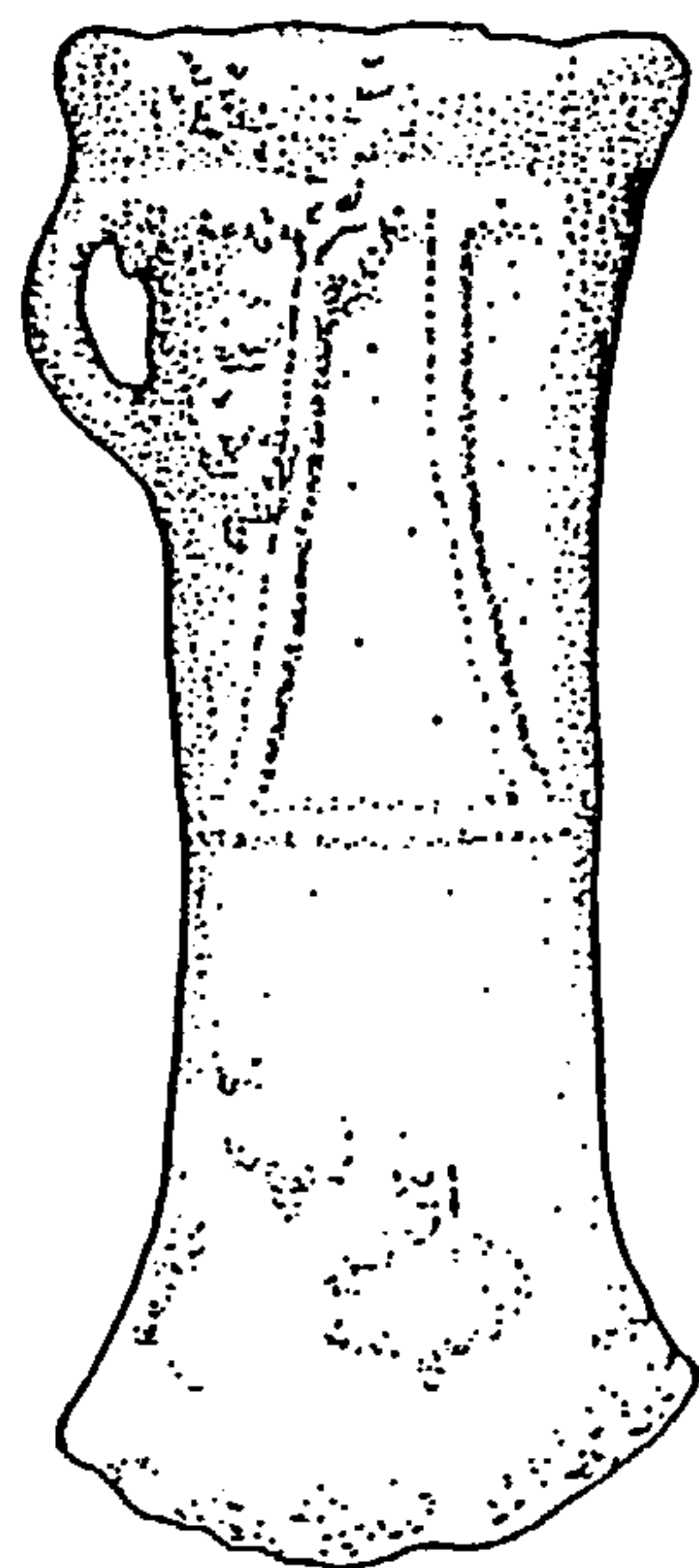
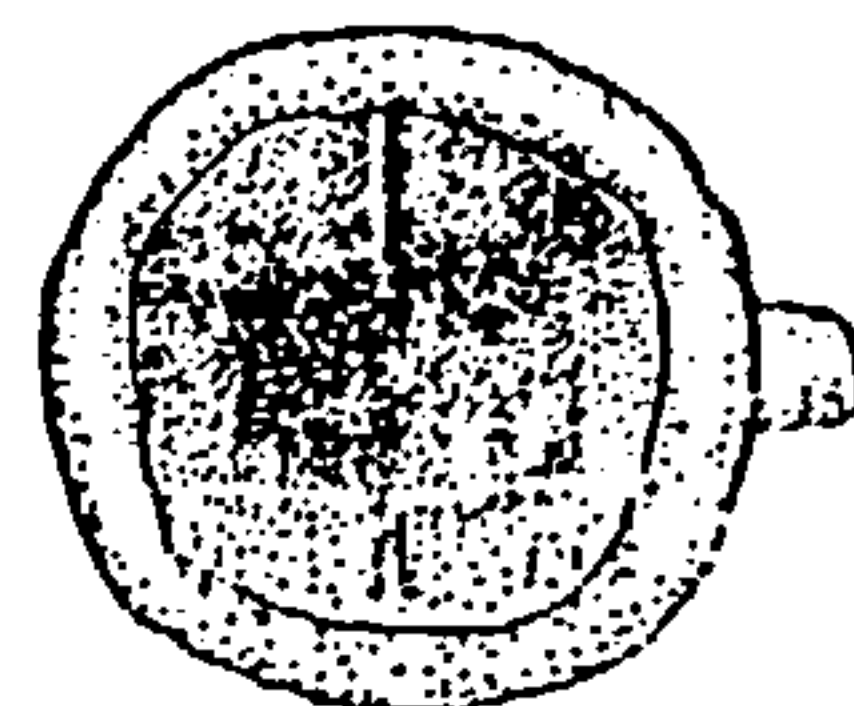
23/02



23/03

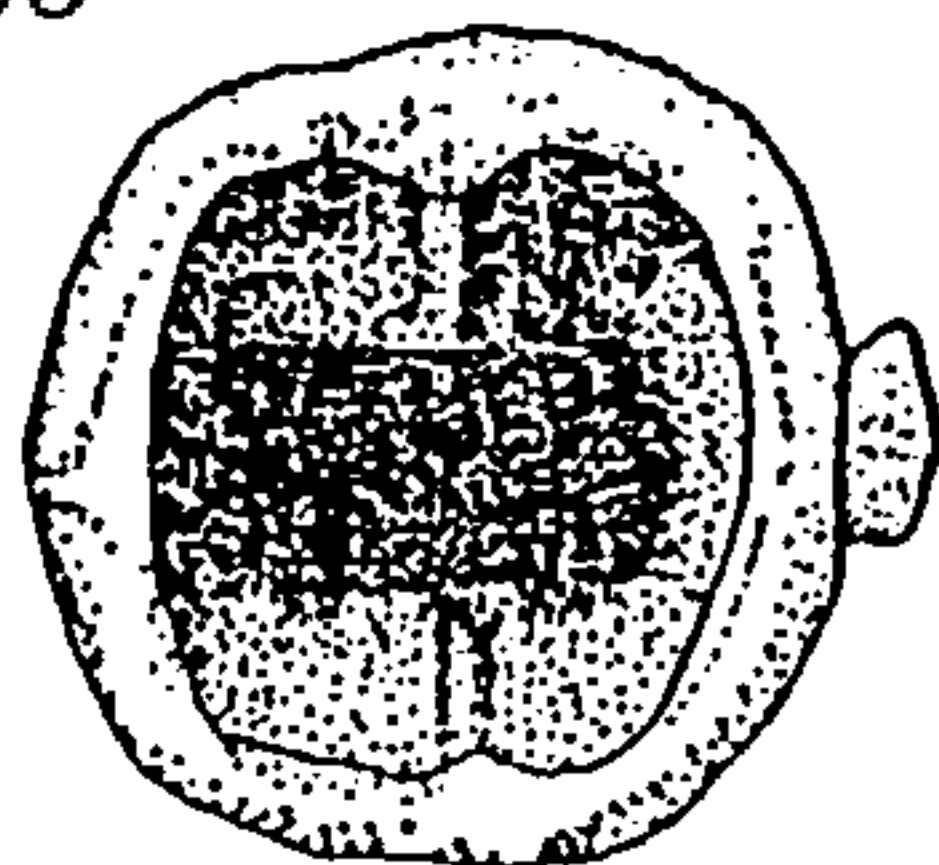


23/04

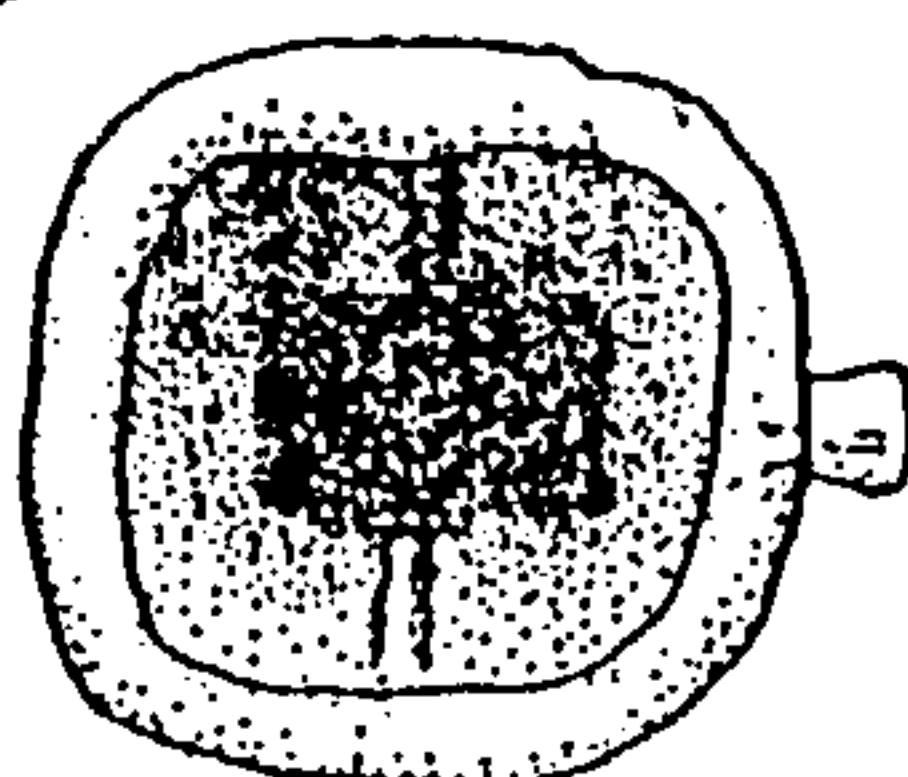


0 2cm

23/05



23/06



23/07

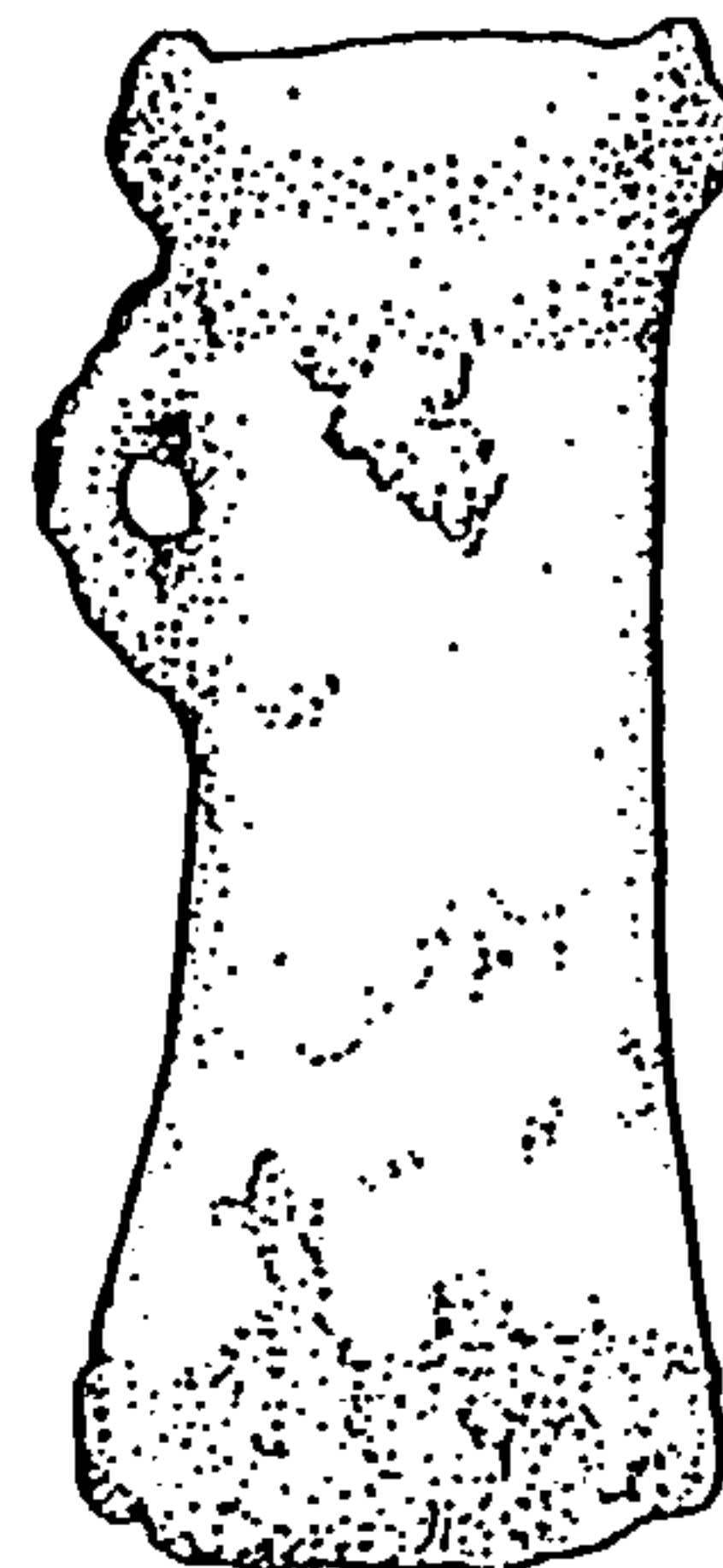
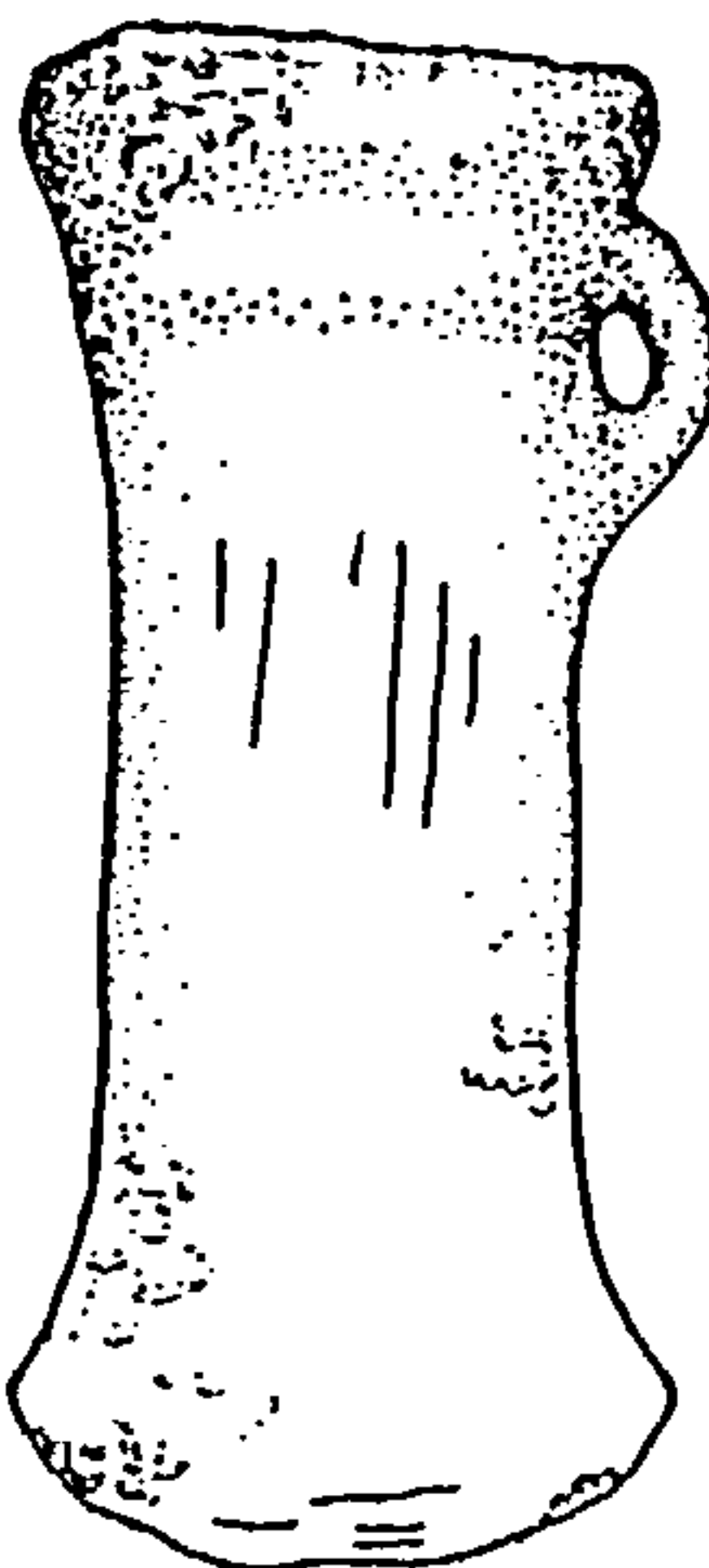
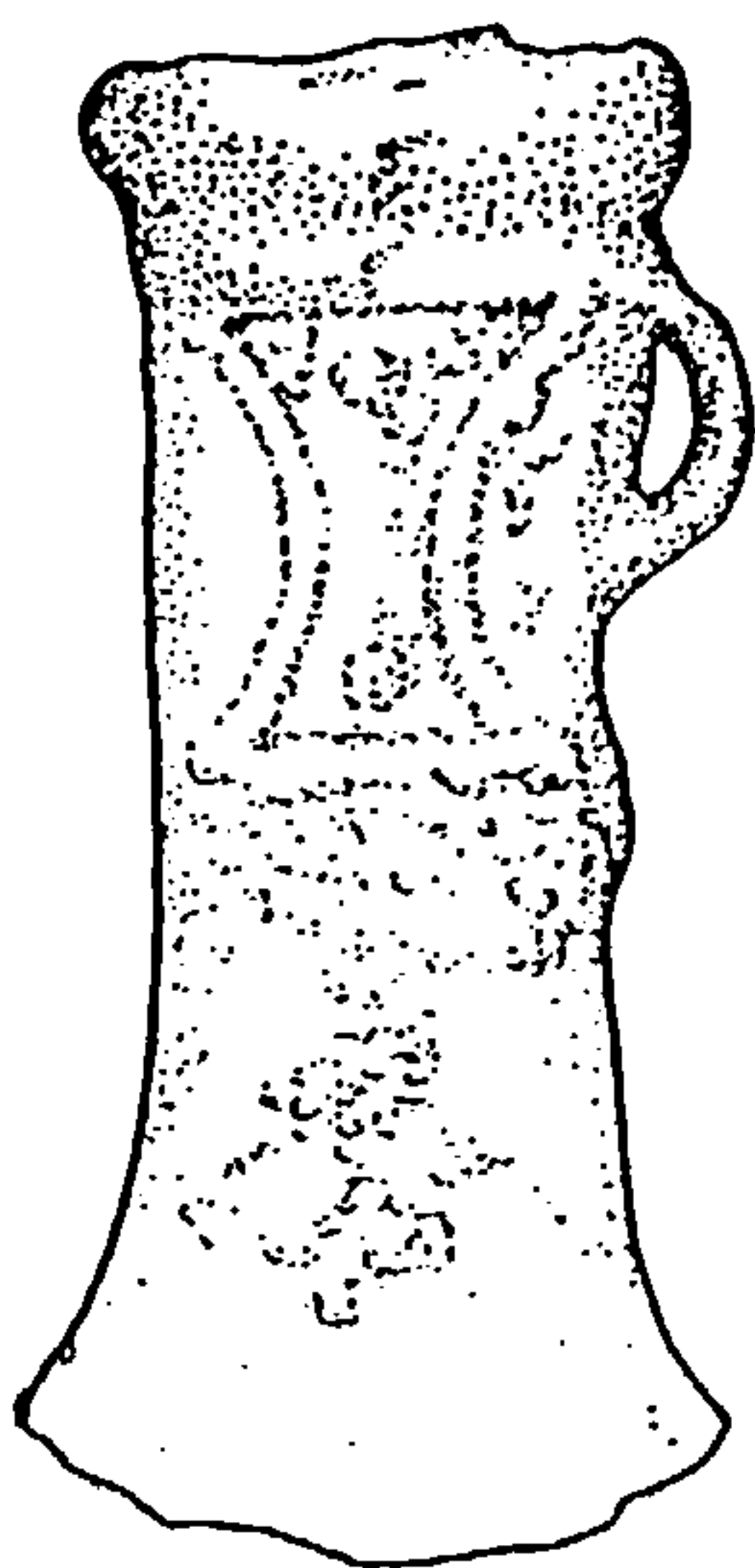
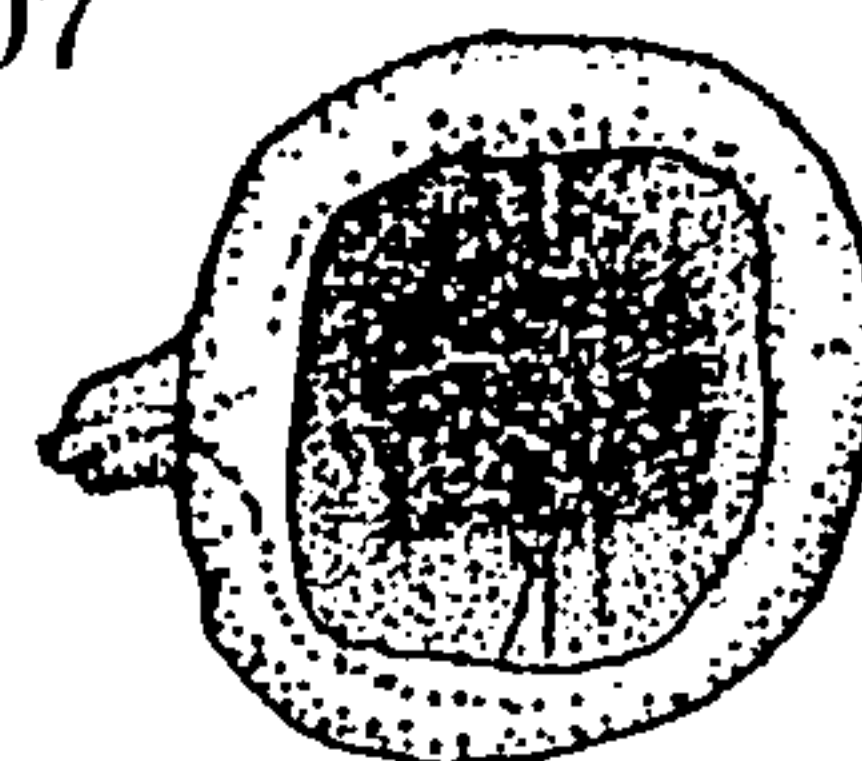
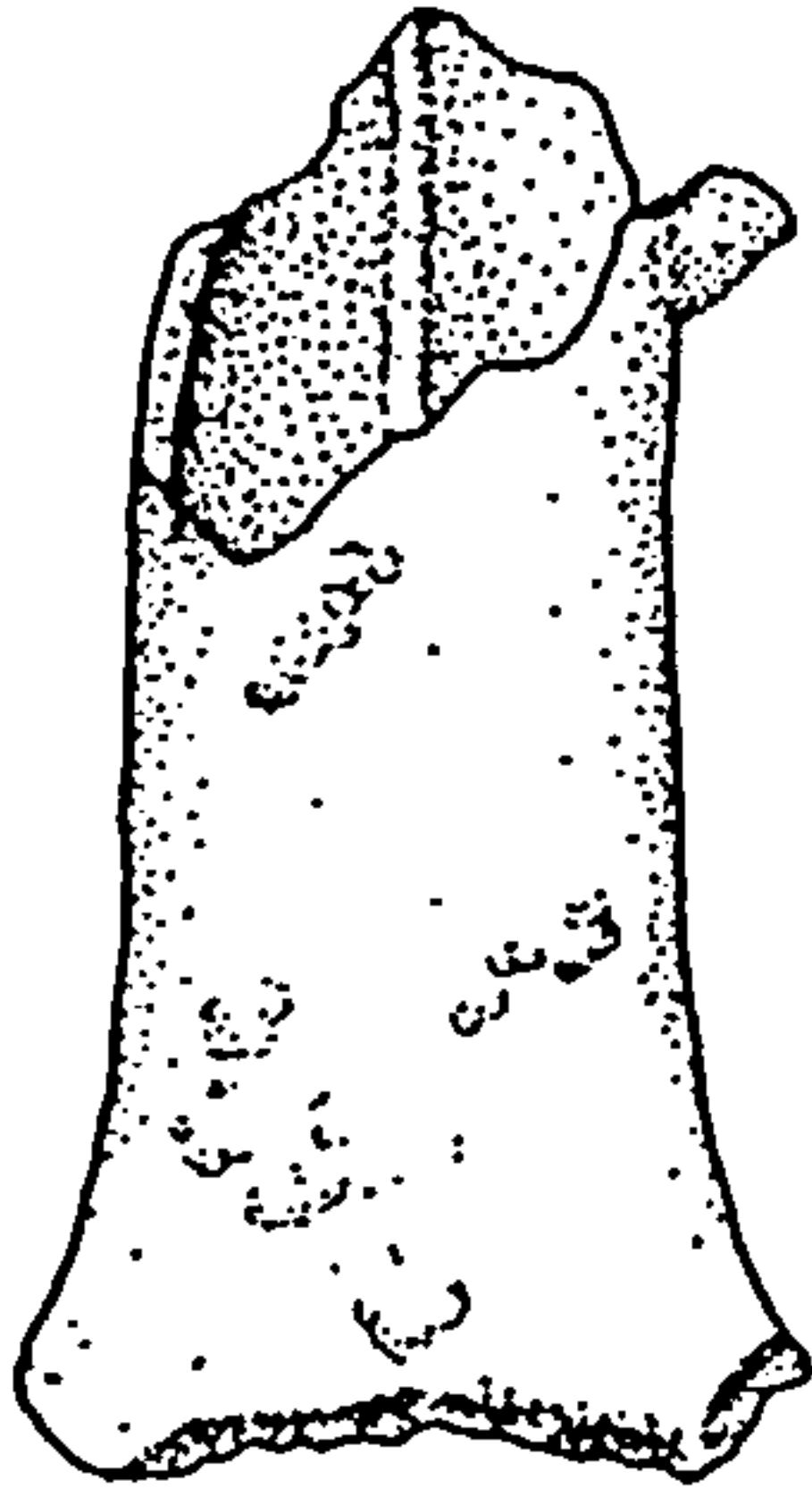
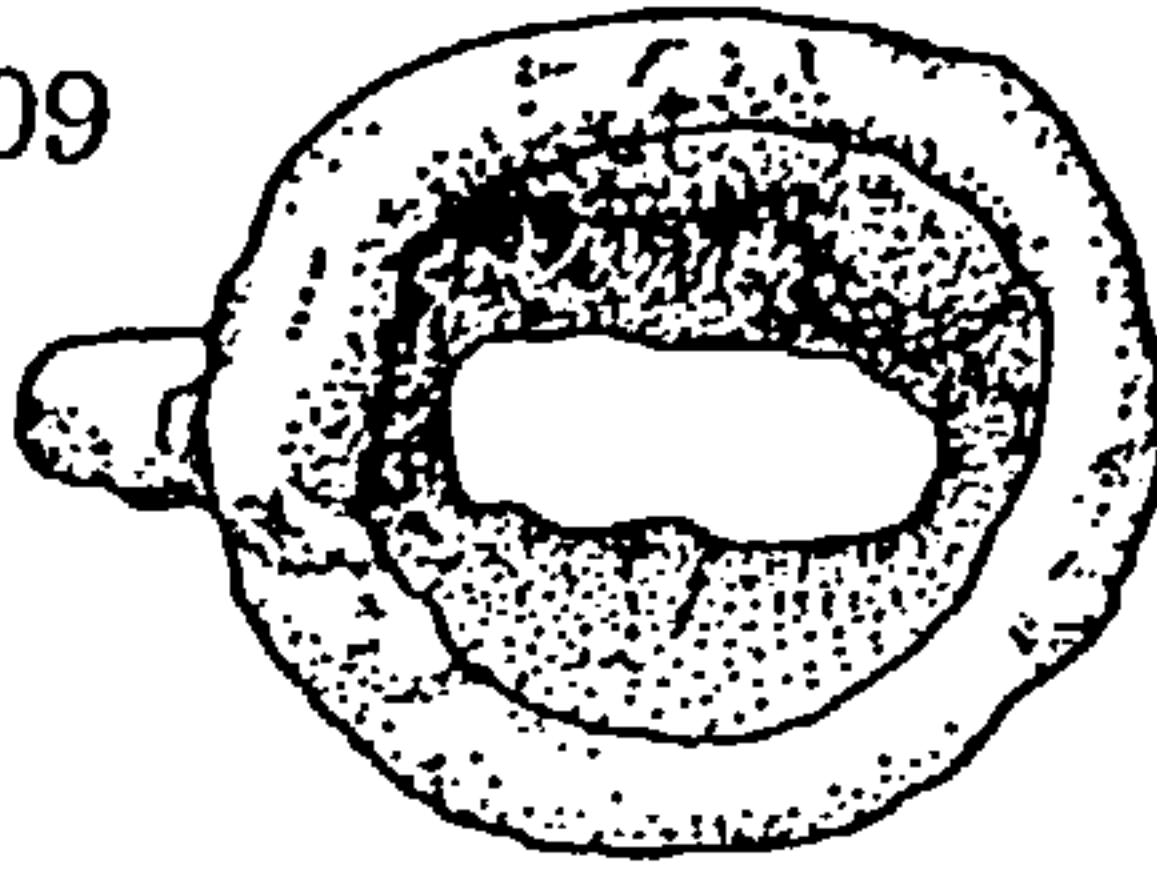


Fig. 89: The Whitstable Hoard (Ref. No. 23): Socketed Axes

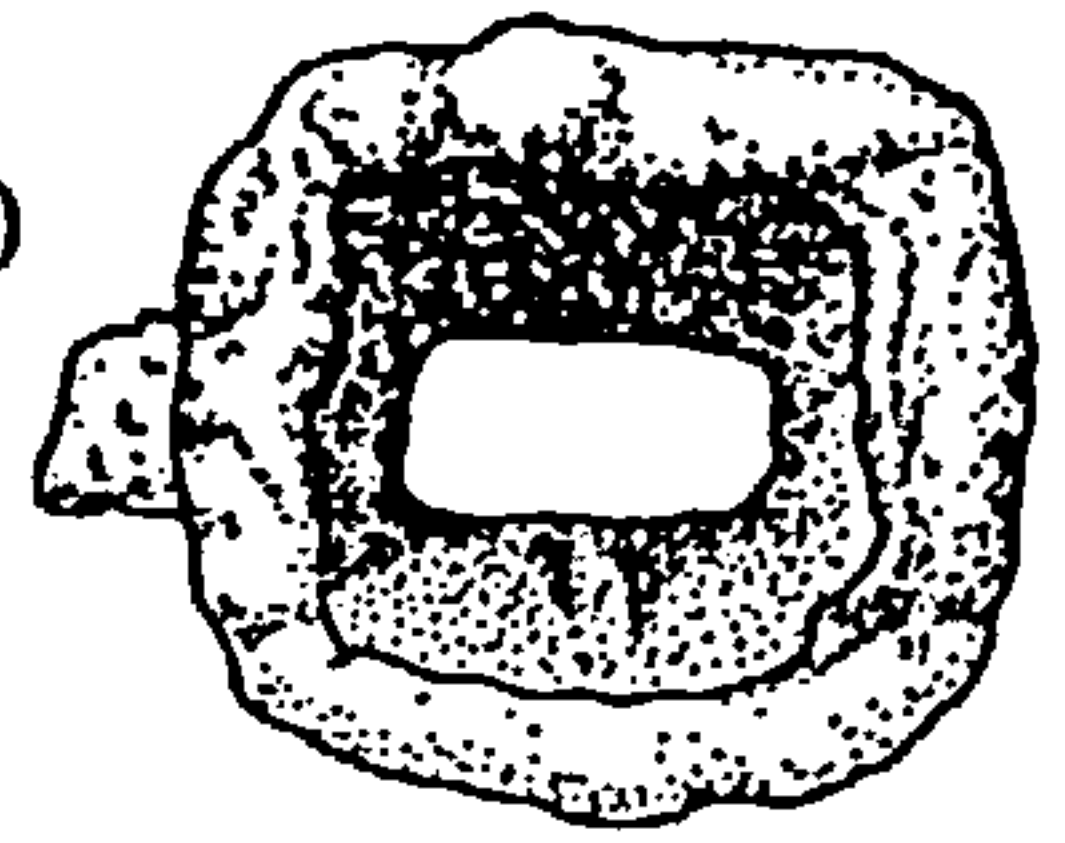
23/08



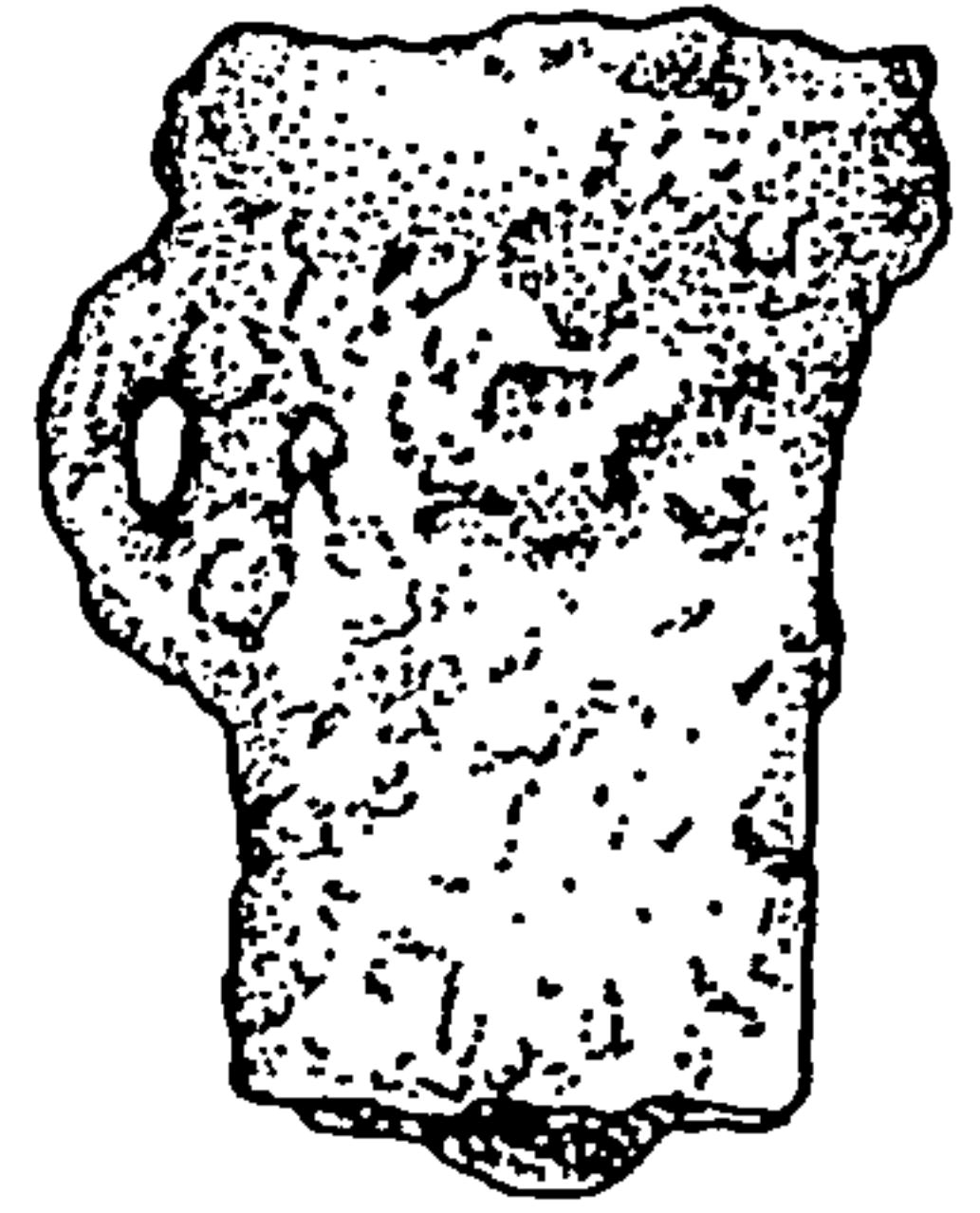
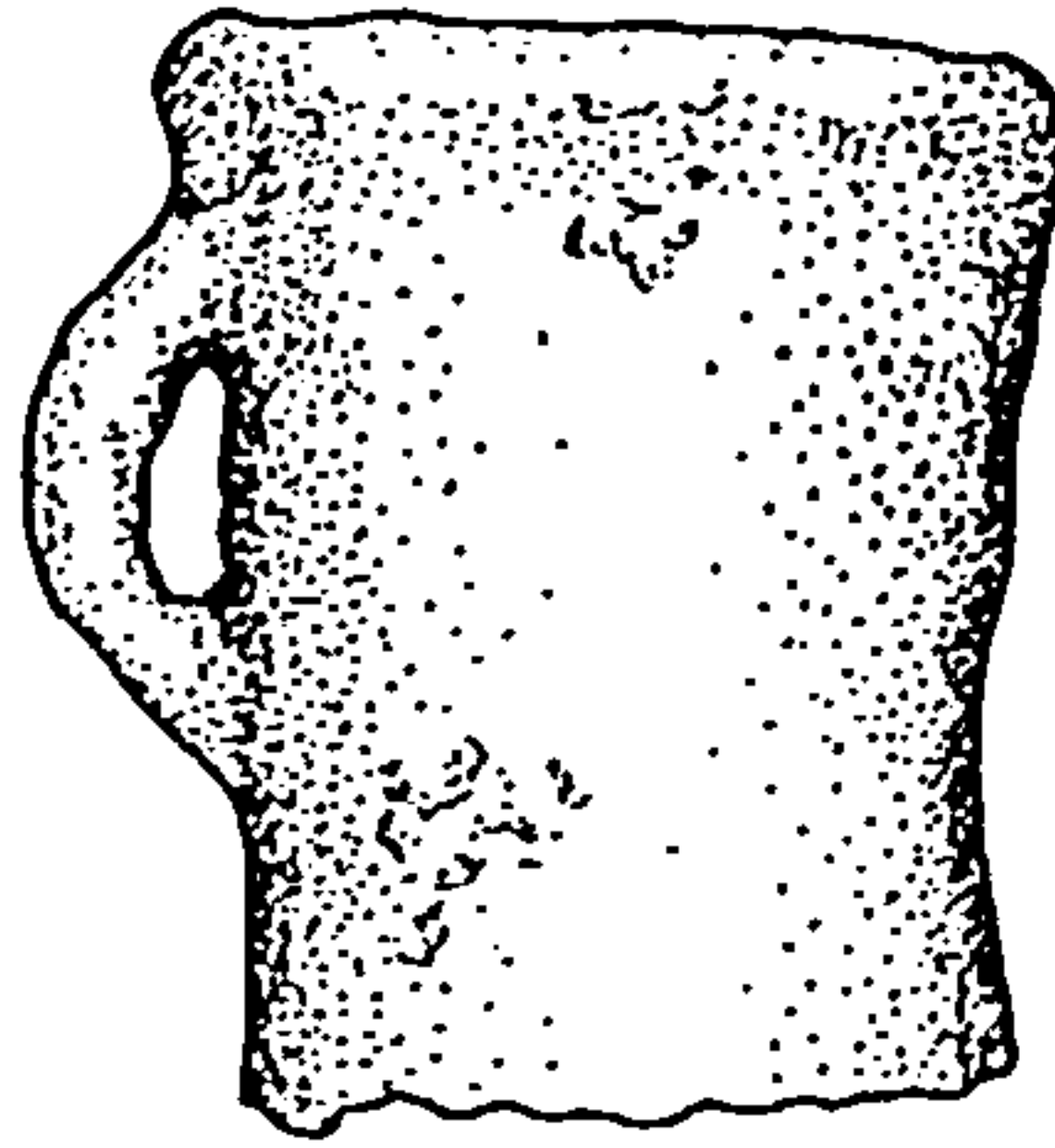
23/09



23/10



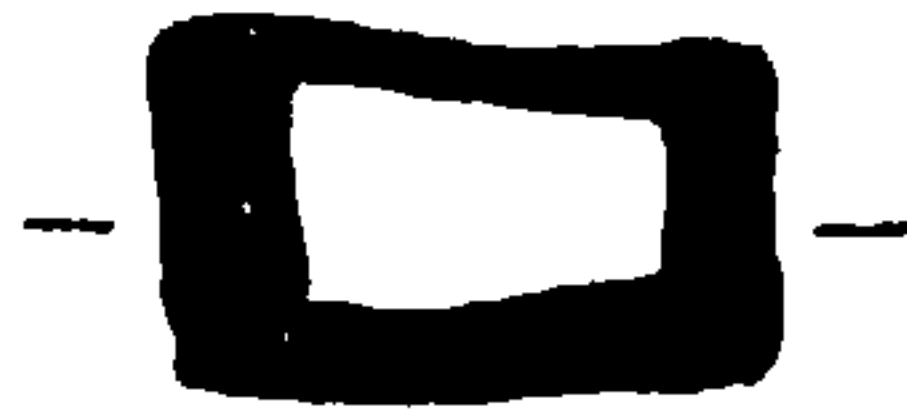
0 2cm



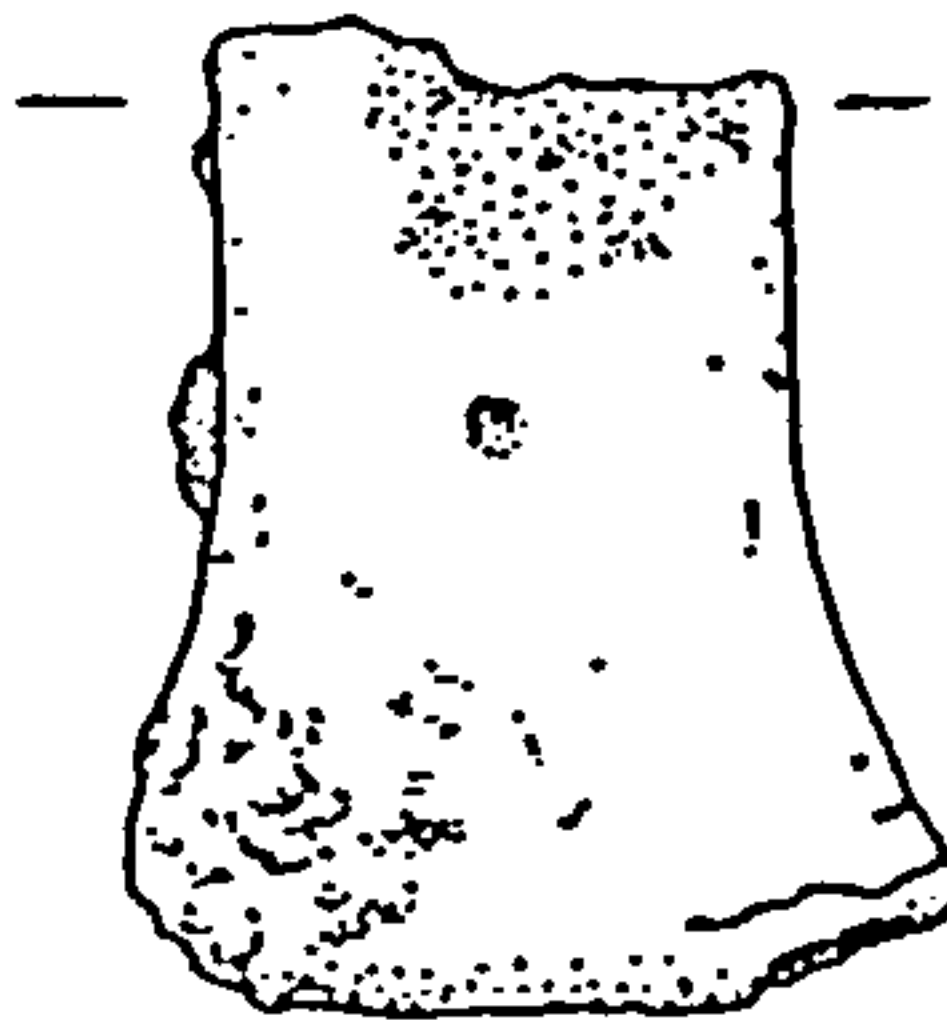
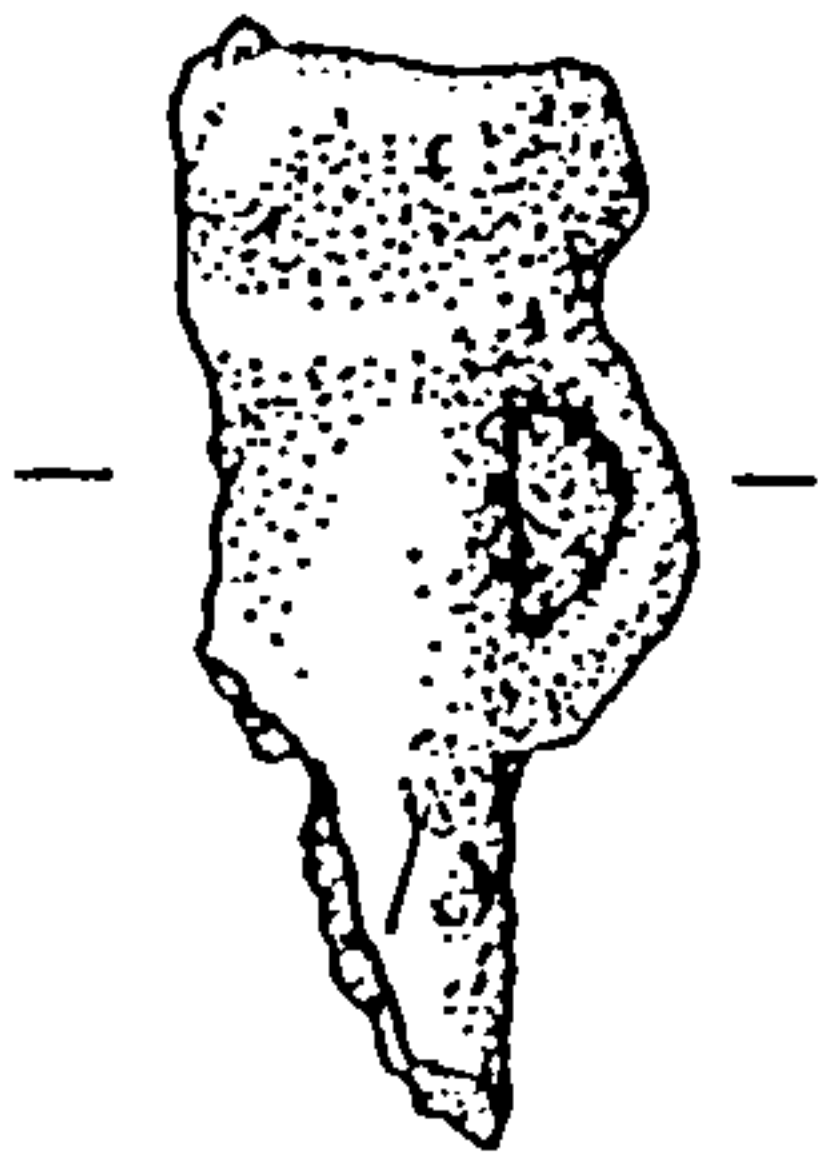
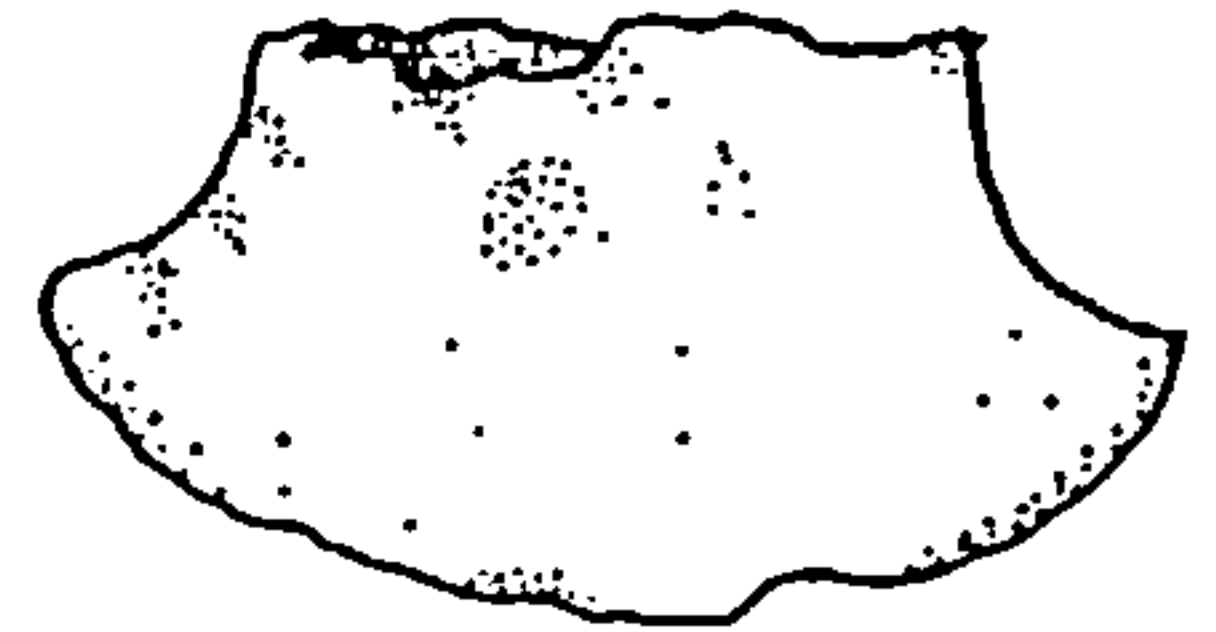
23/11



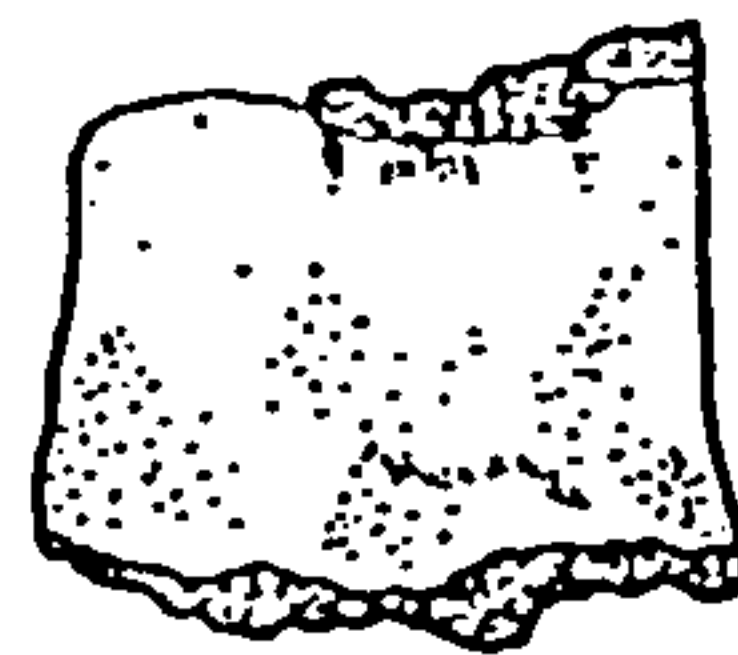
23/12



23/13



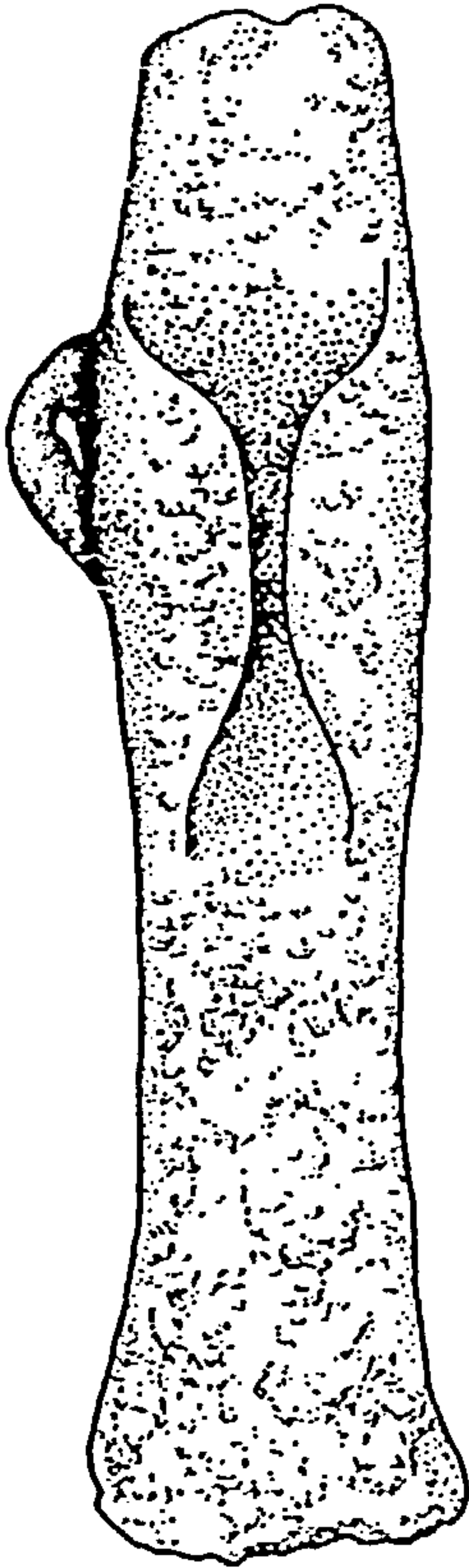
23/14



 Rough Metal/Corrosion Product

Fig. 90: The Whitstable Hoard (Ref. No. 23): Socketed Axe Fragments

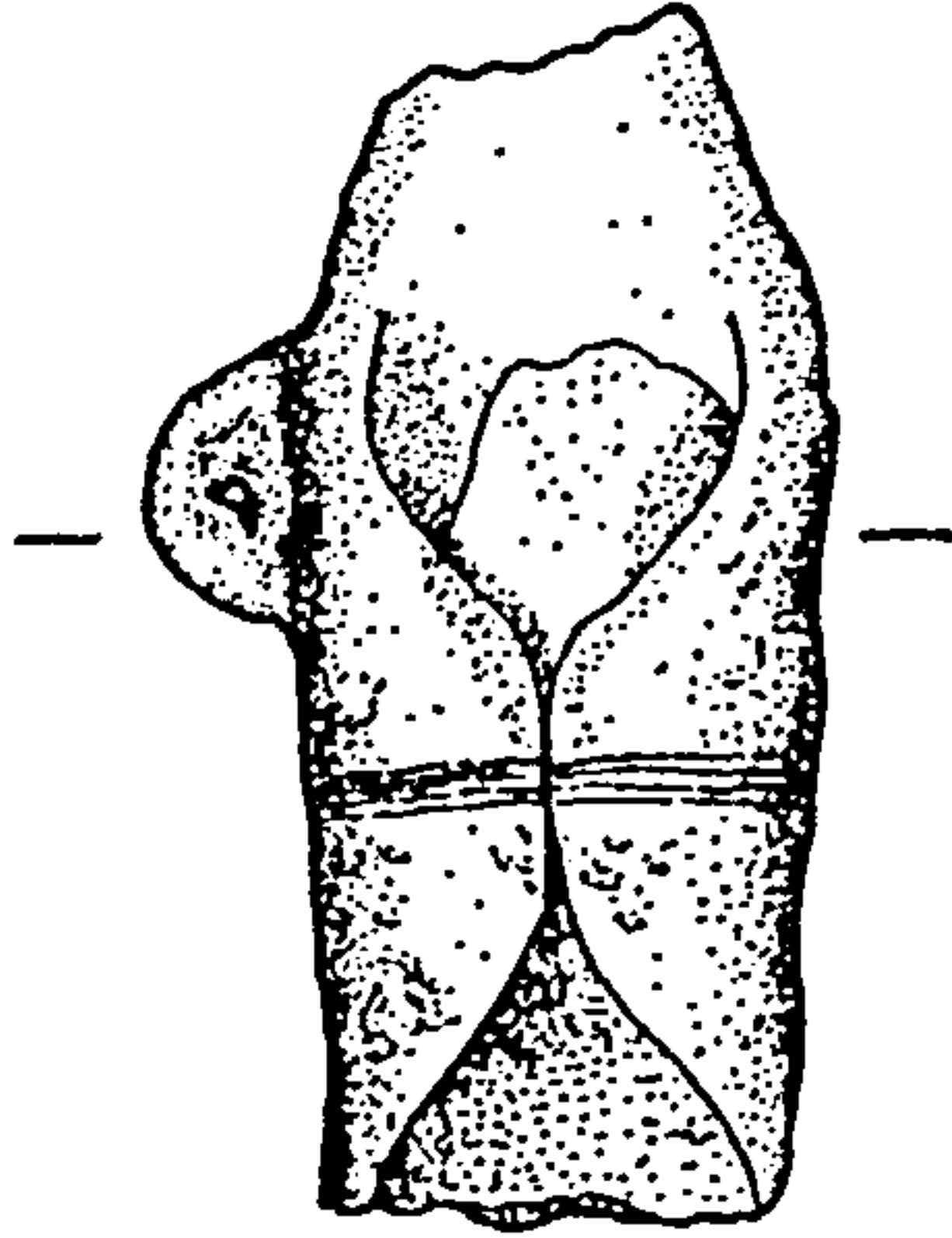
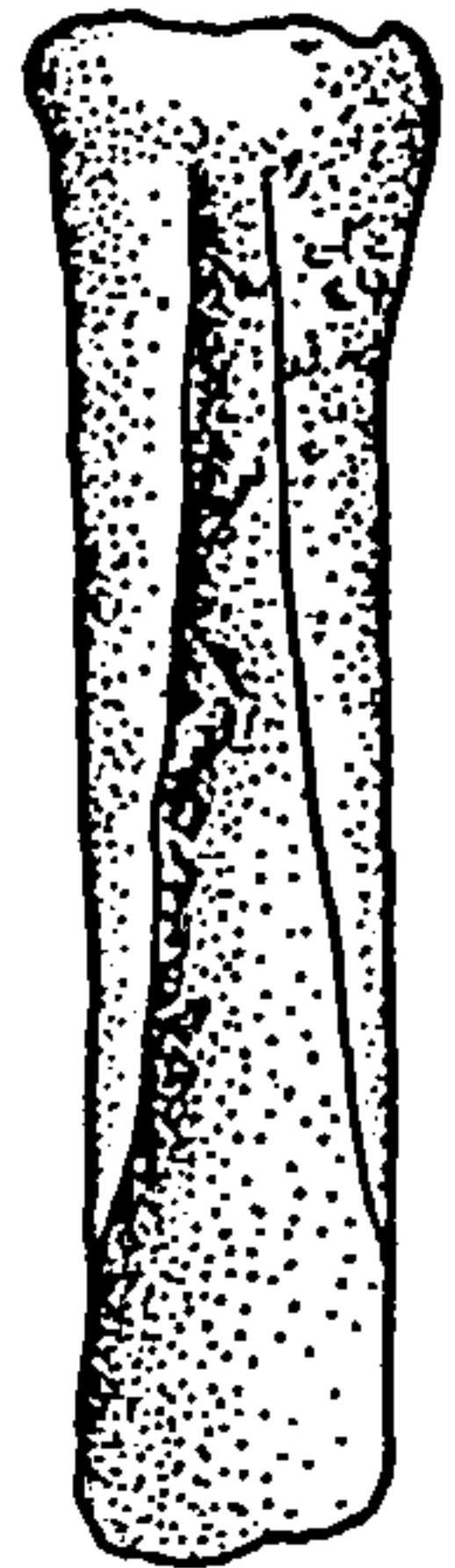
23/15




23/16



23/17



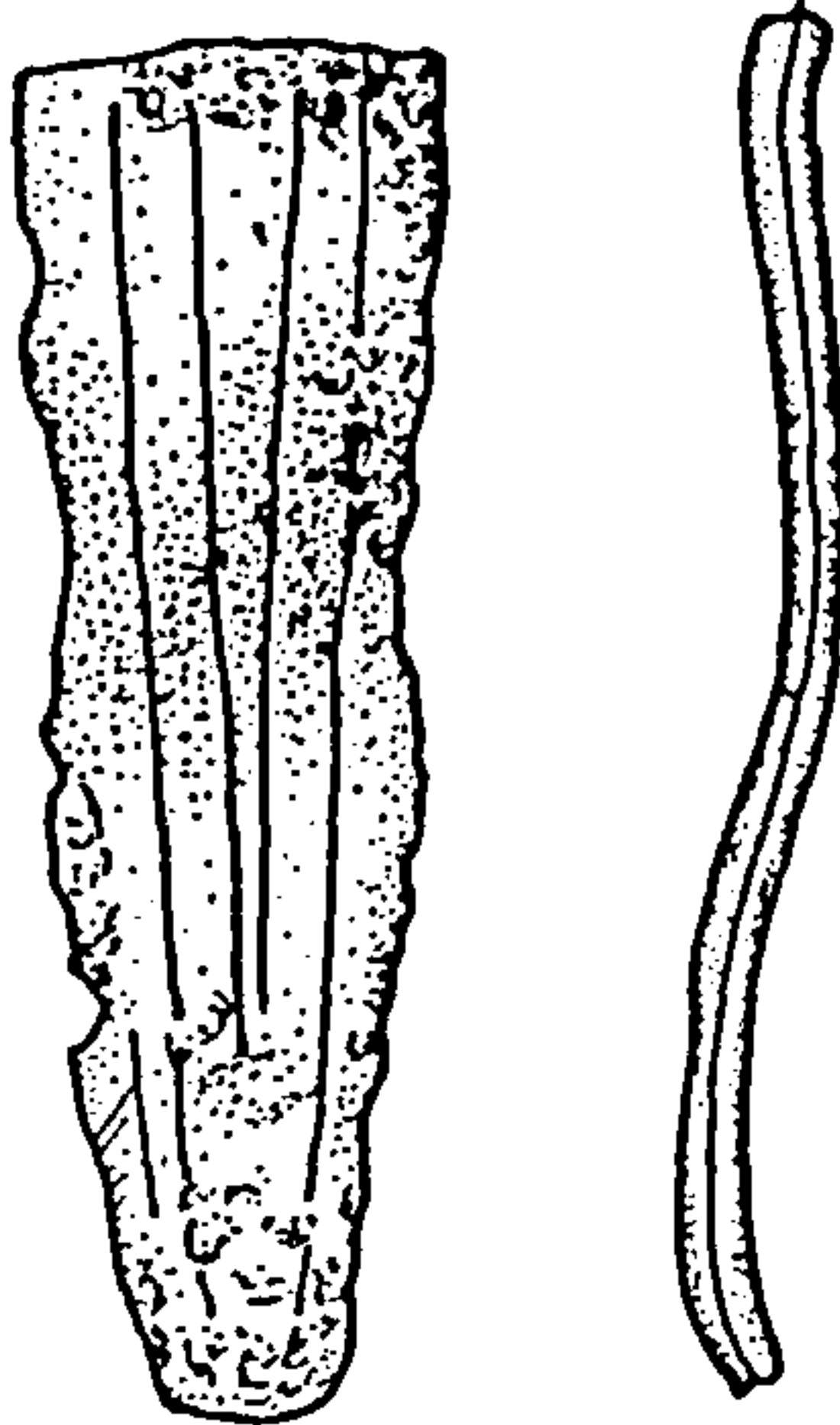
0 2cm

 Stone (?Inserted)

23/18



23/19



23/20

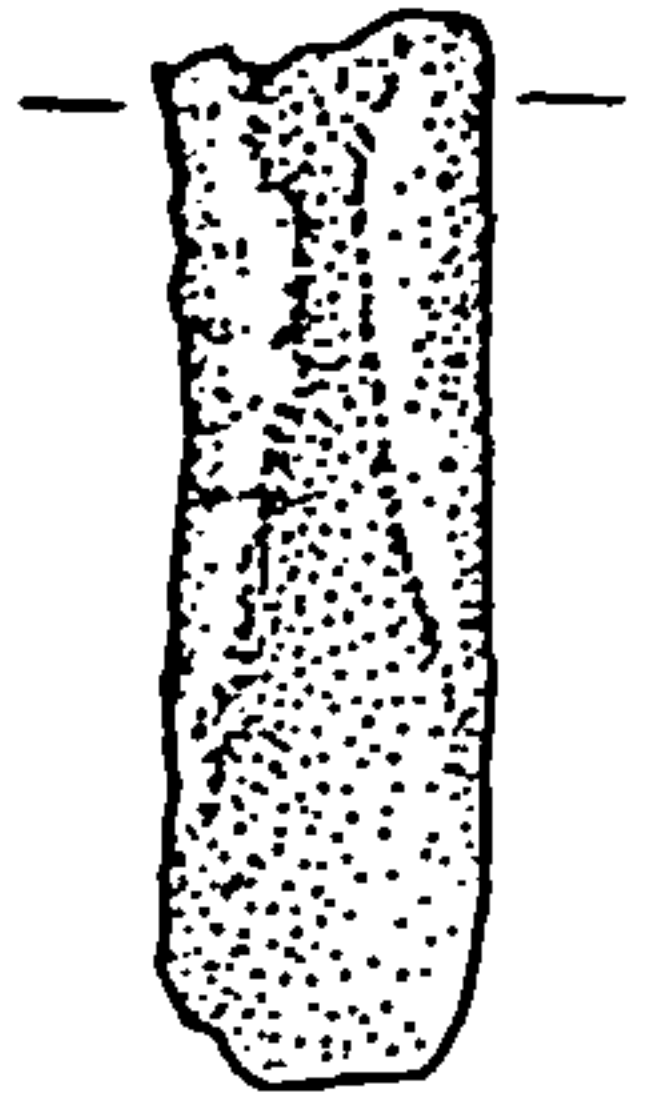
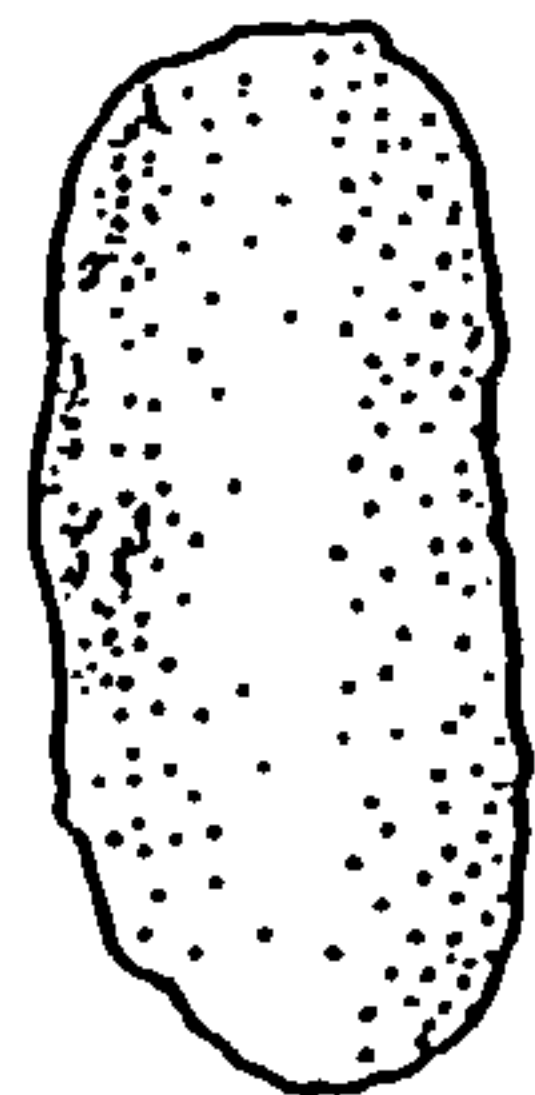
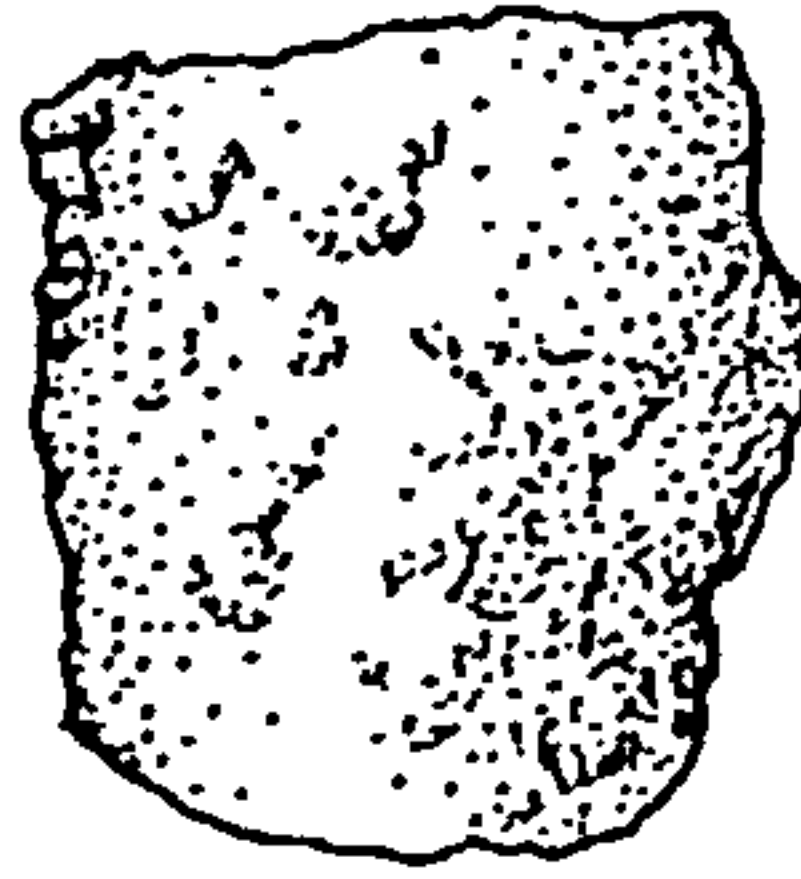


Fig. 91: The Whitstable Hoard (Ref. No. 23): Winged Axes and Small Tools

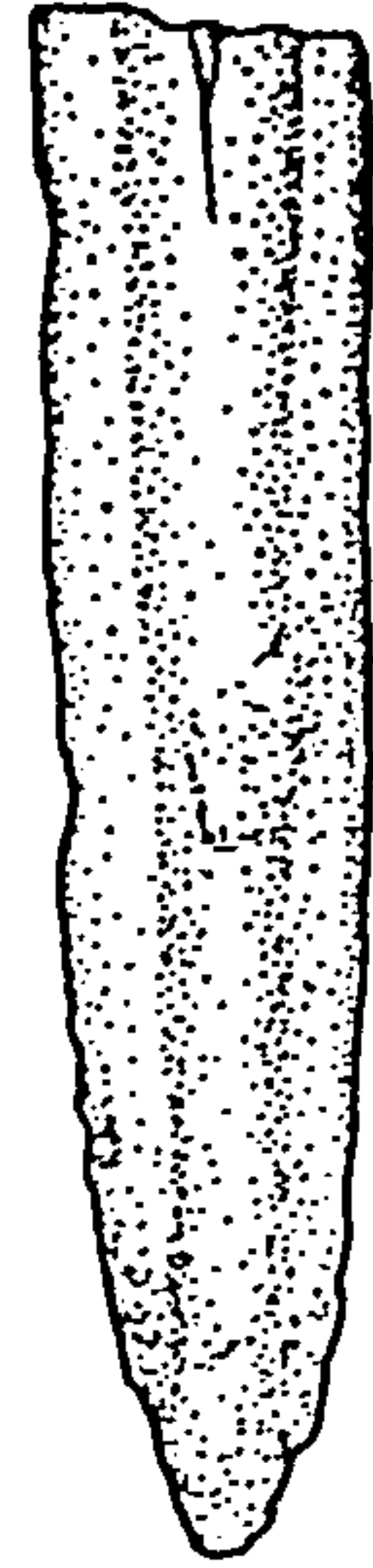
23/21



23/22



23/23

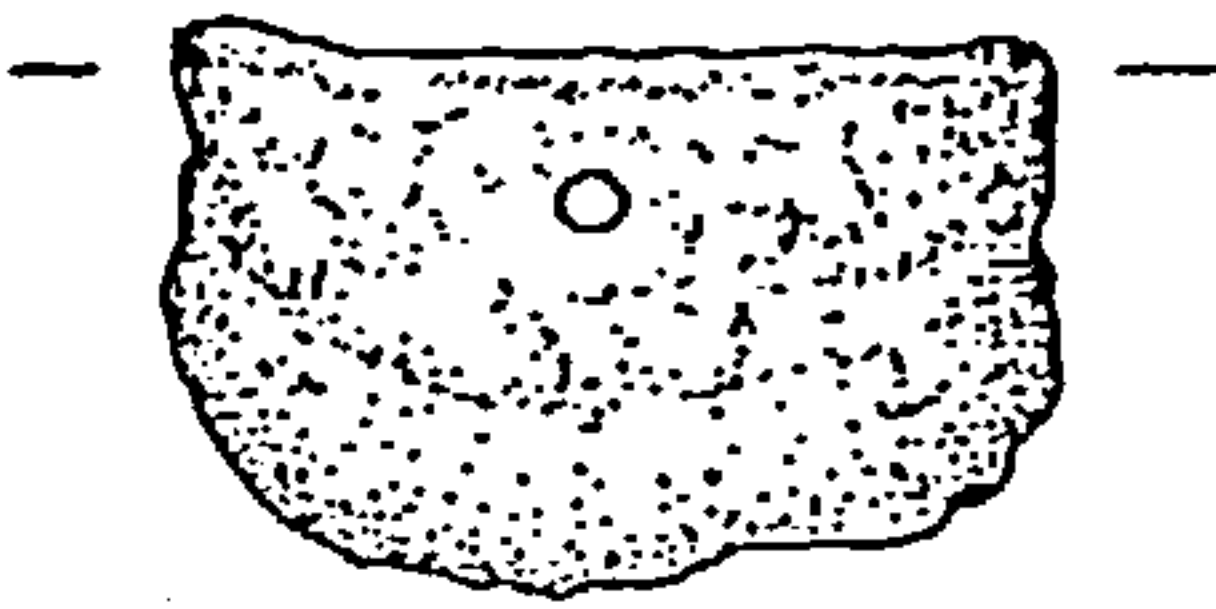


23/24



0 2cm

 Clay



23/25



23/26



23/27

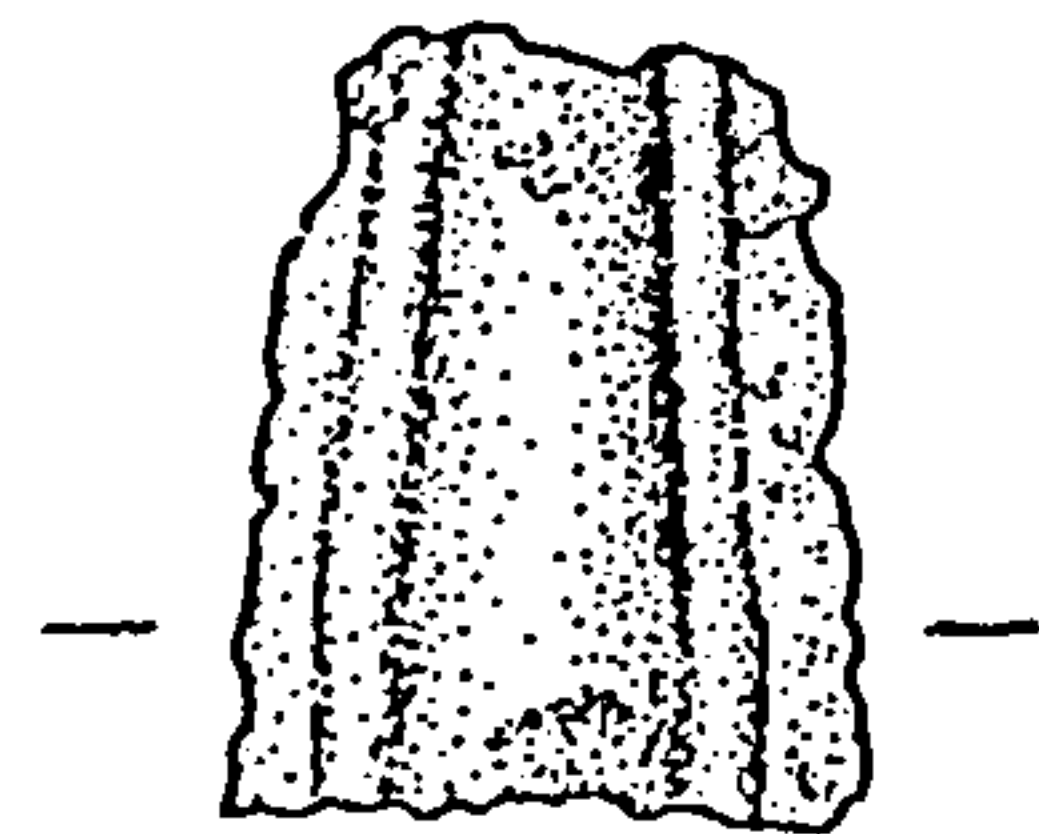
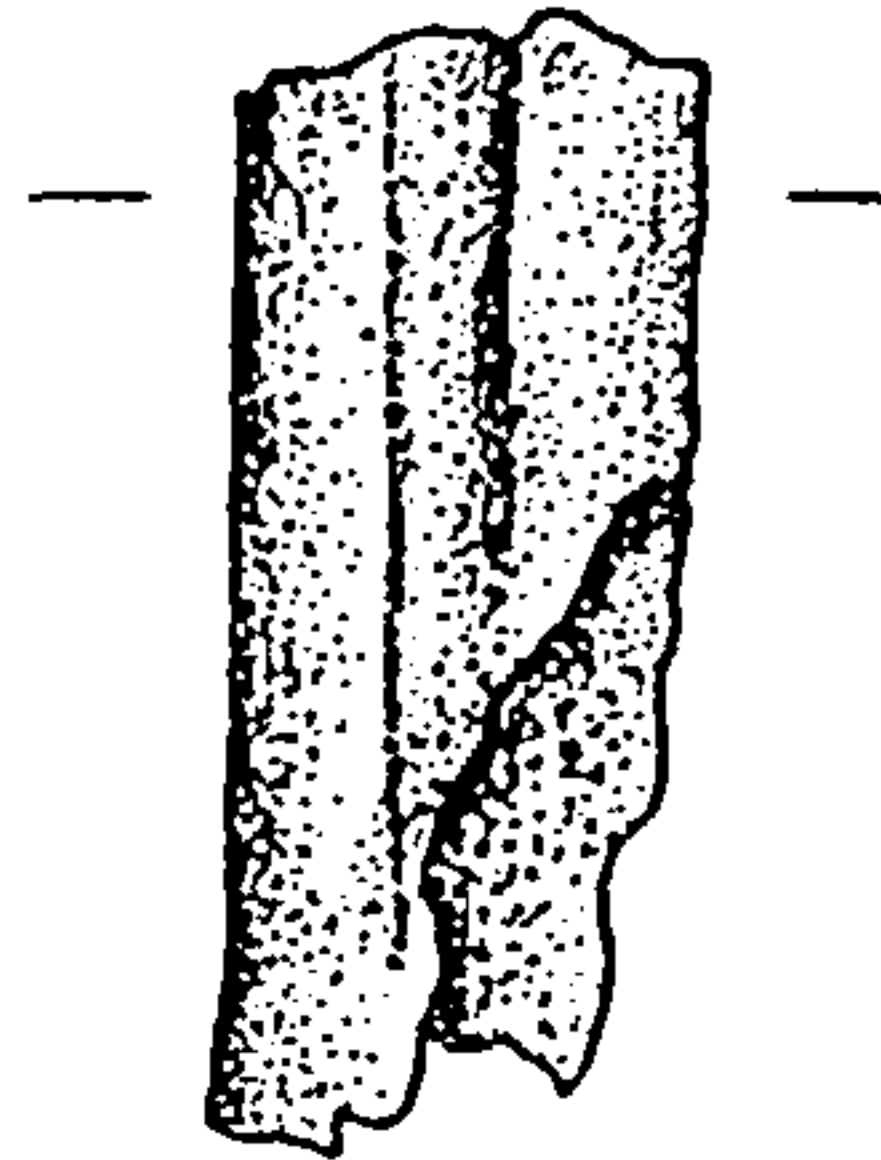
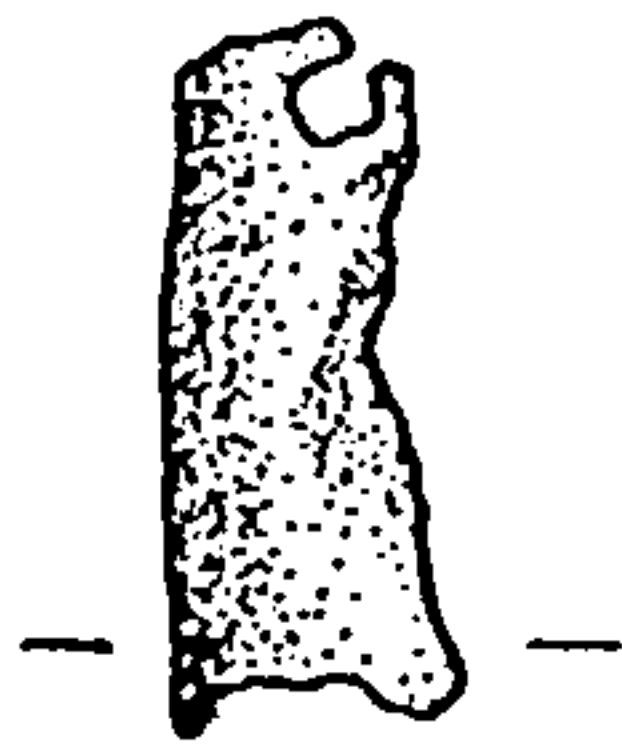
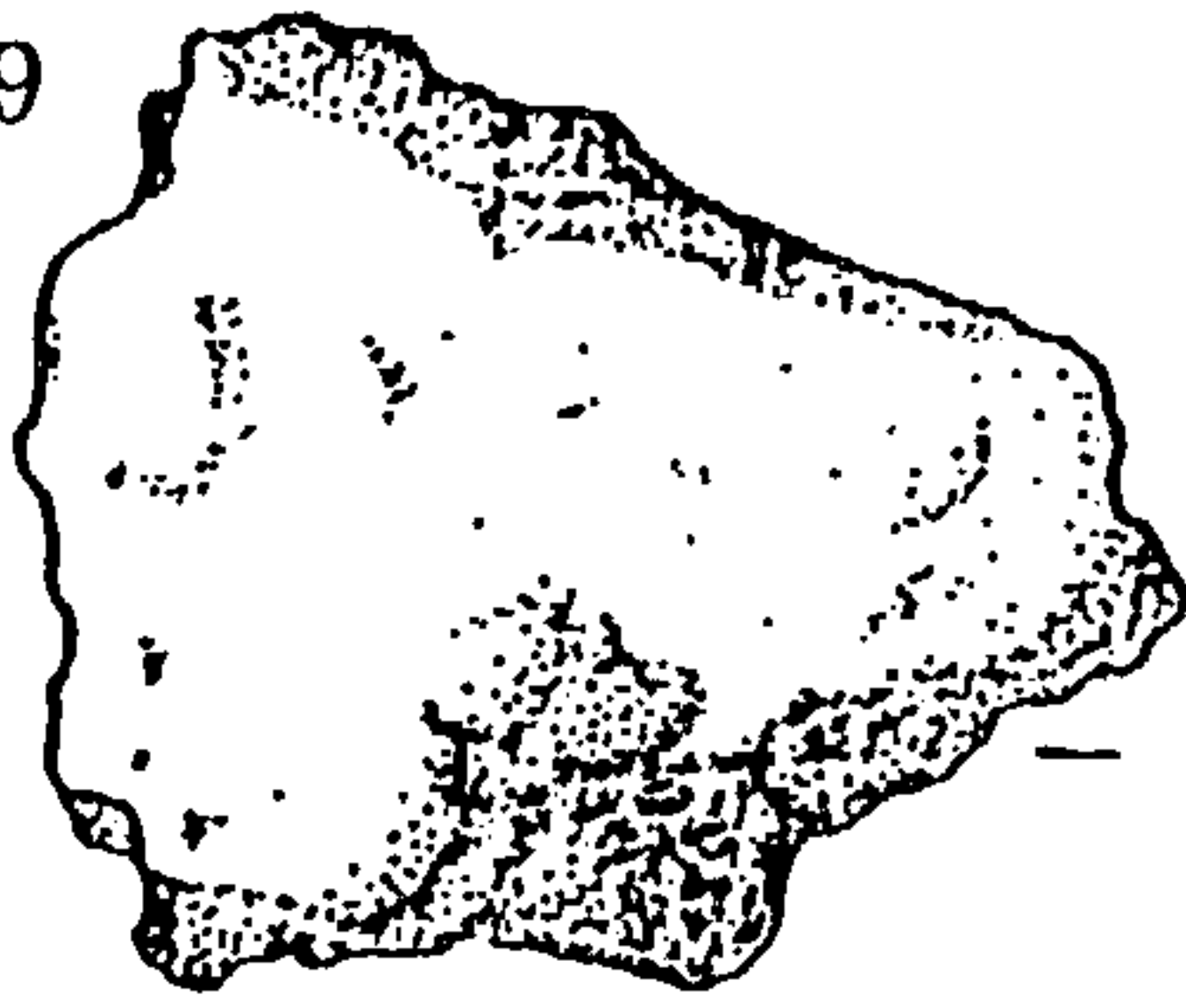


Fig. 92: The Whitstable Hoard (Ref. No. 23): Weaponry

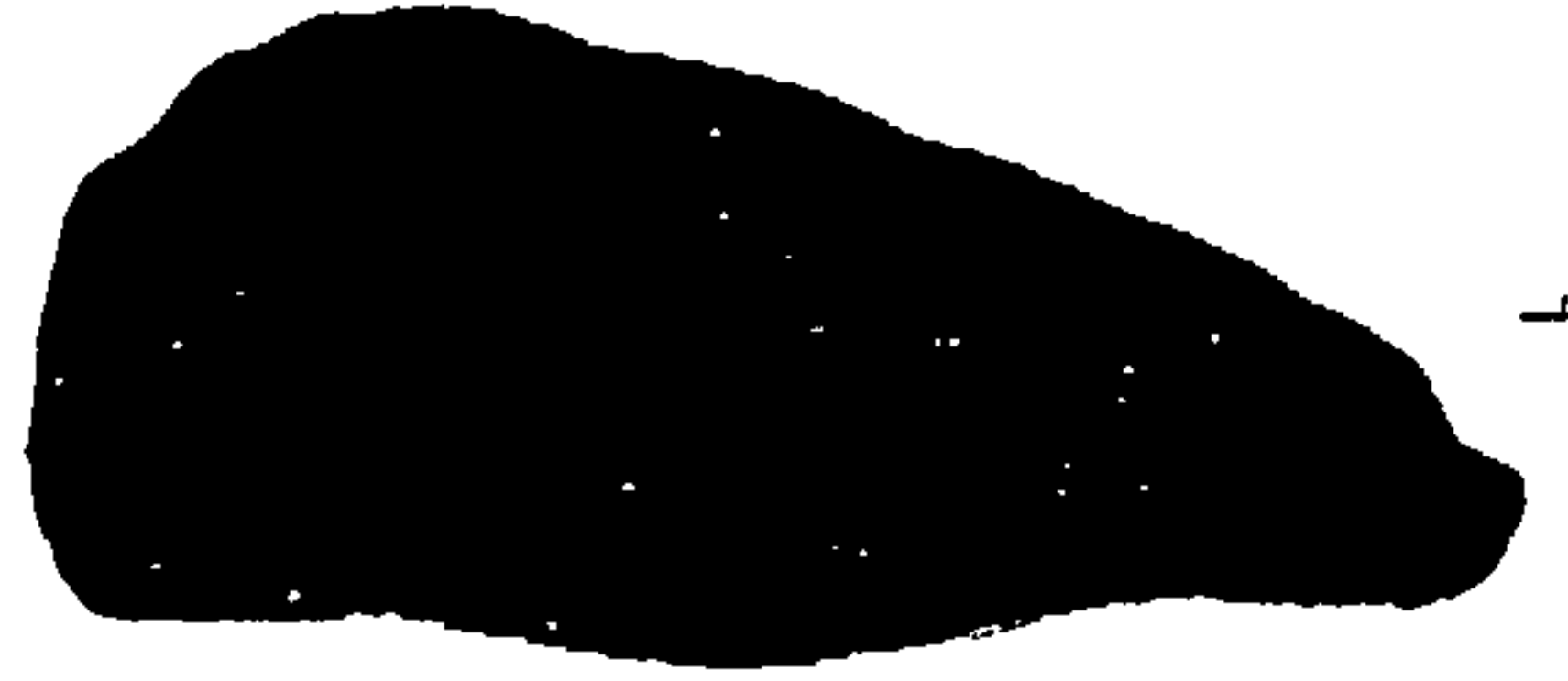
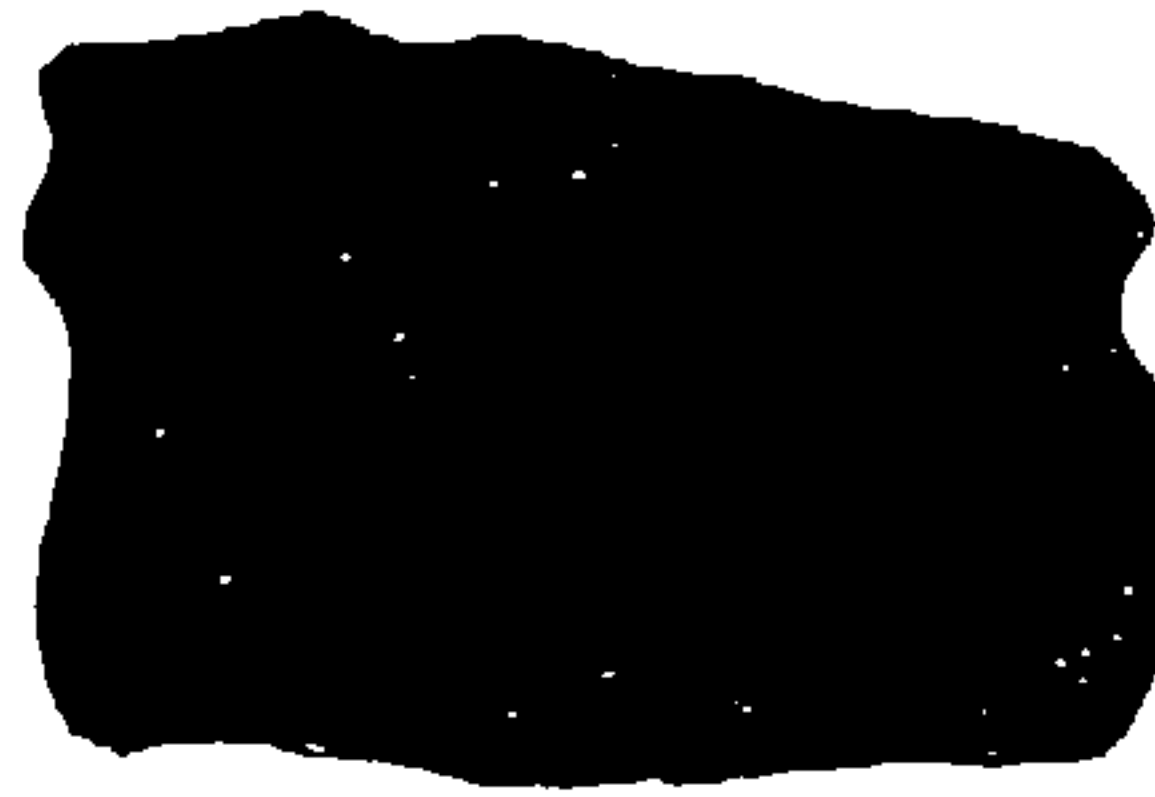
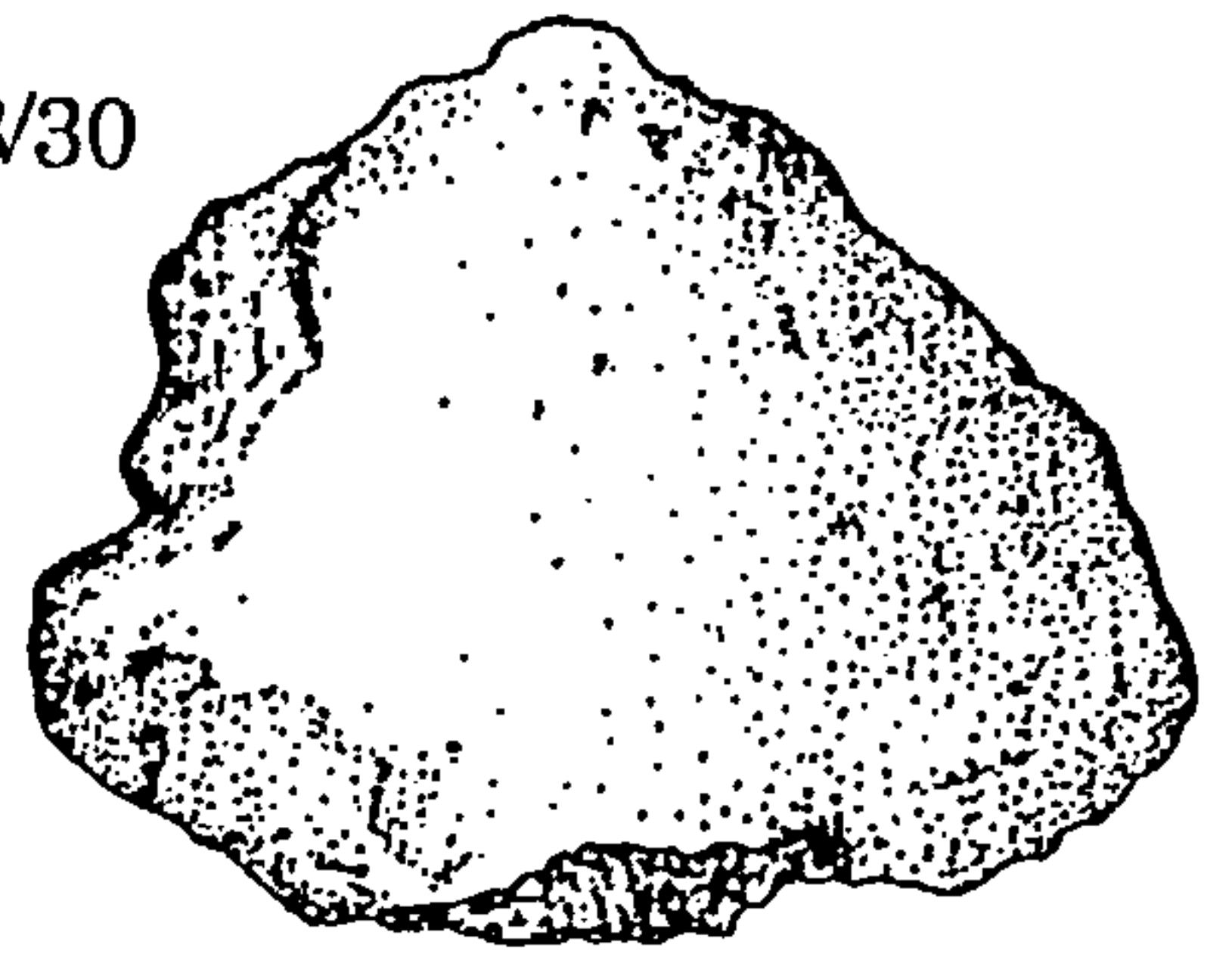
23/28



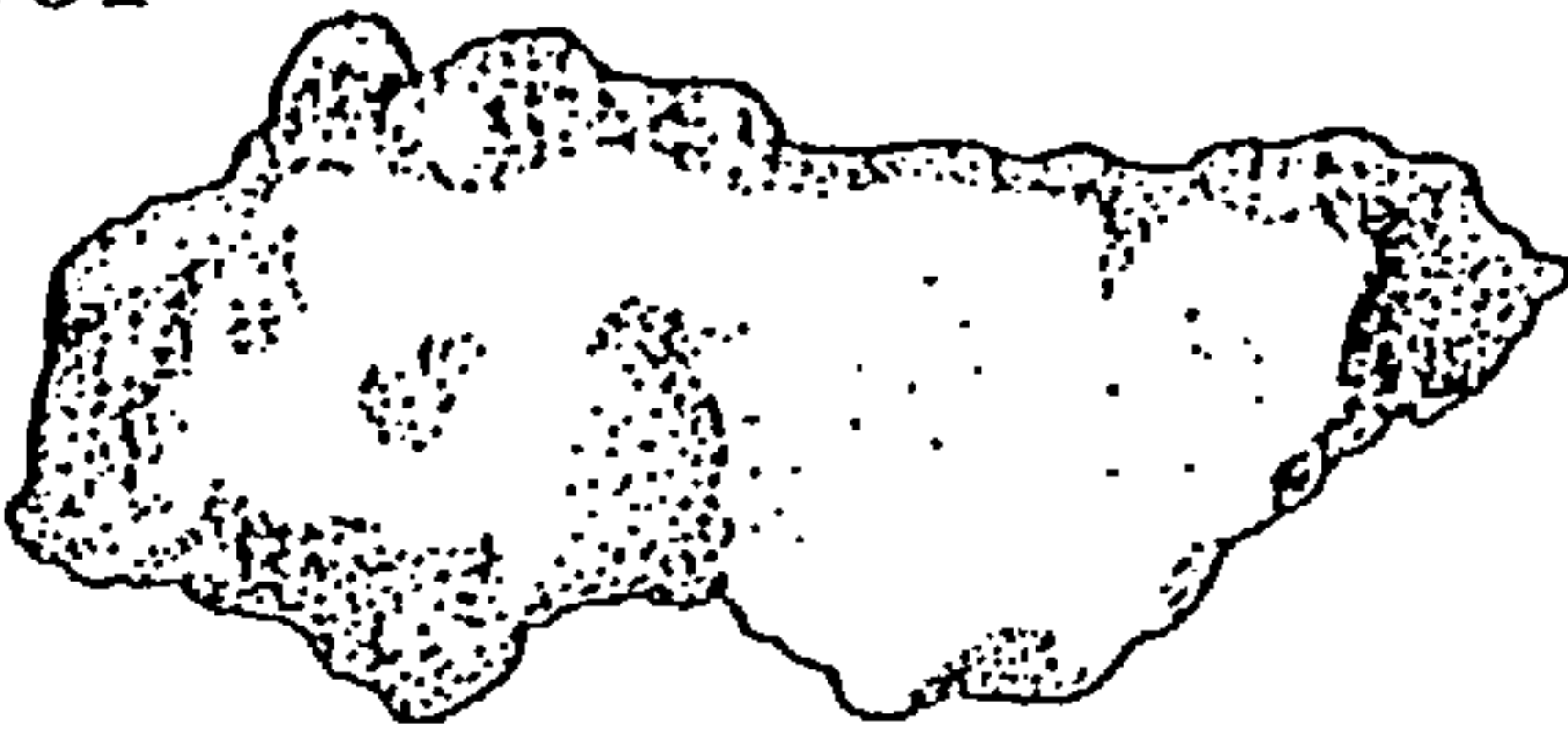
23/29



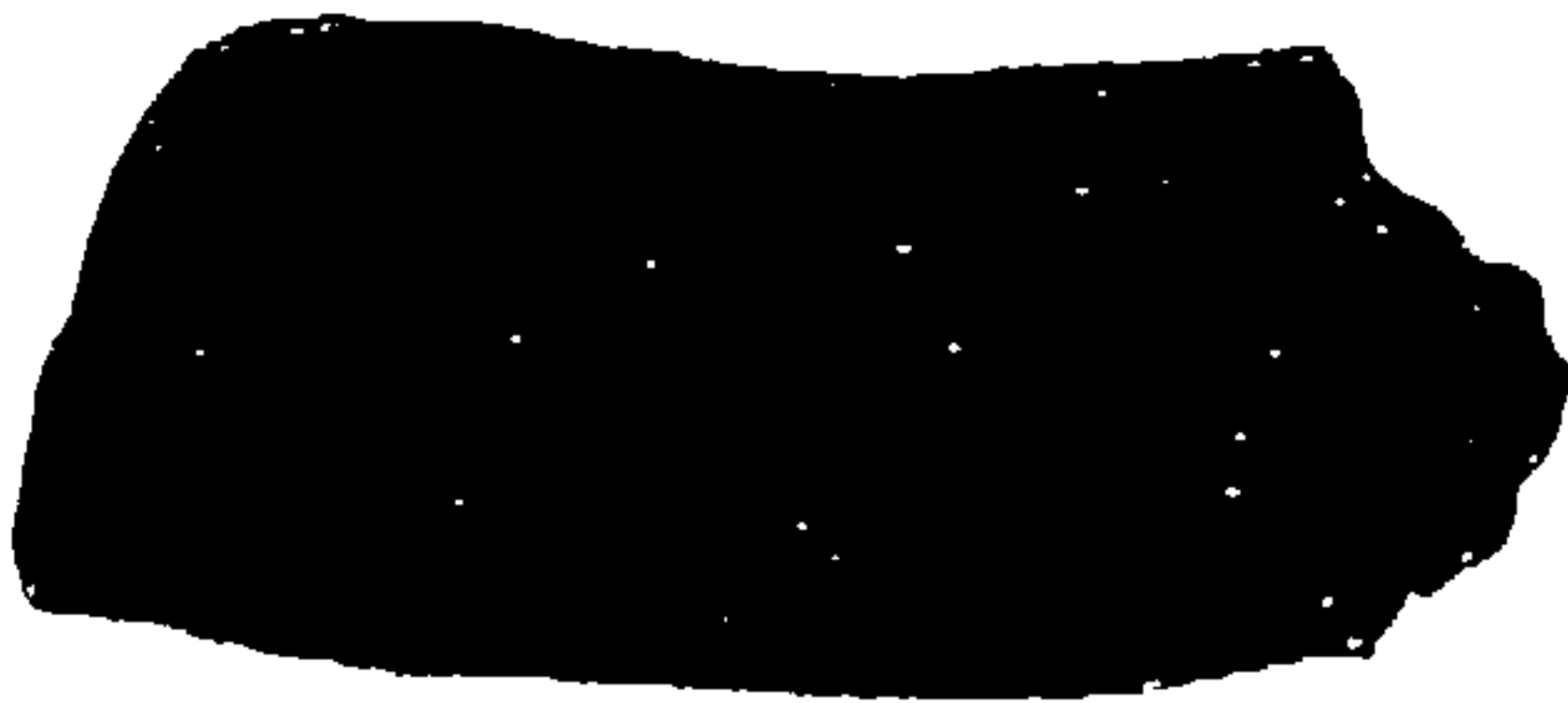
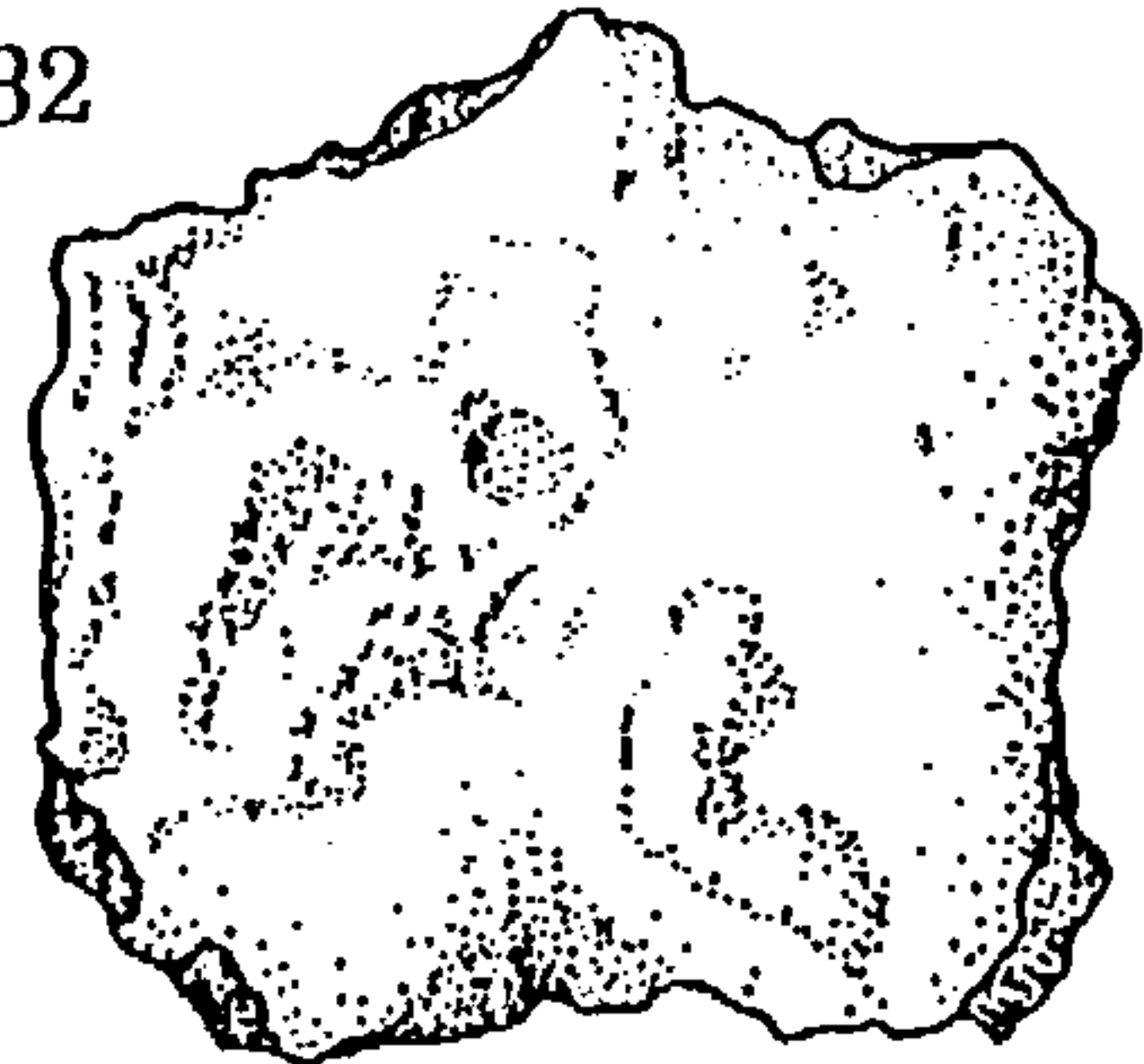
23/30



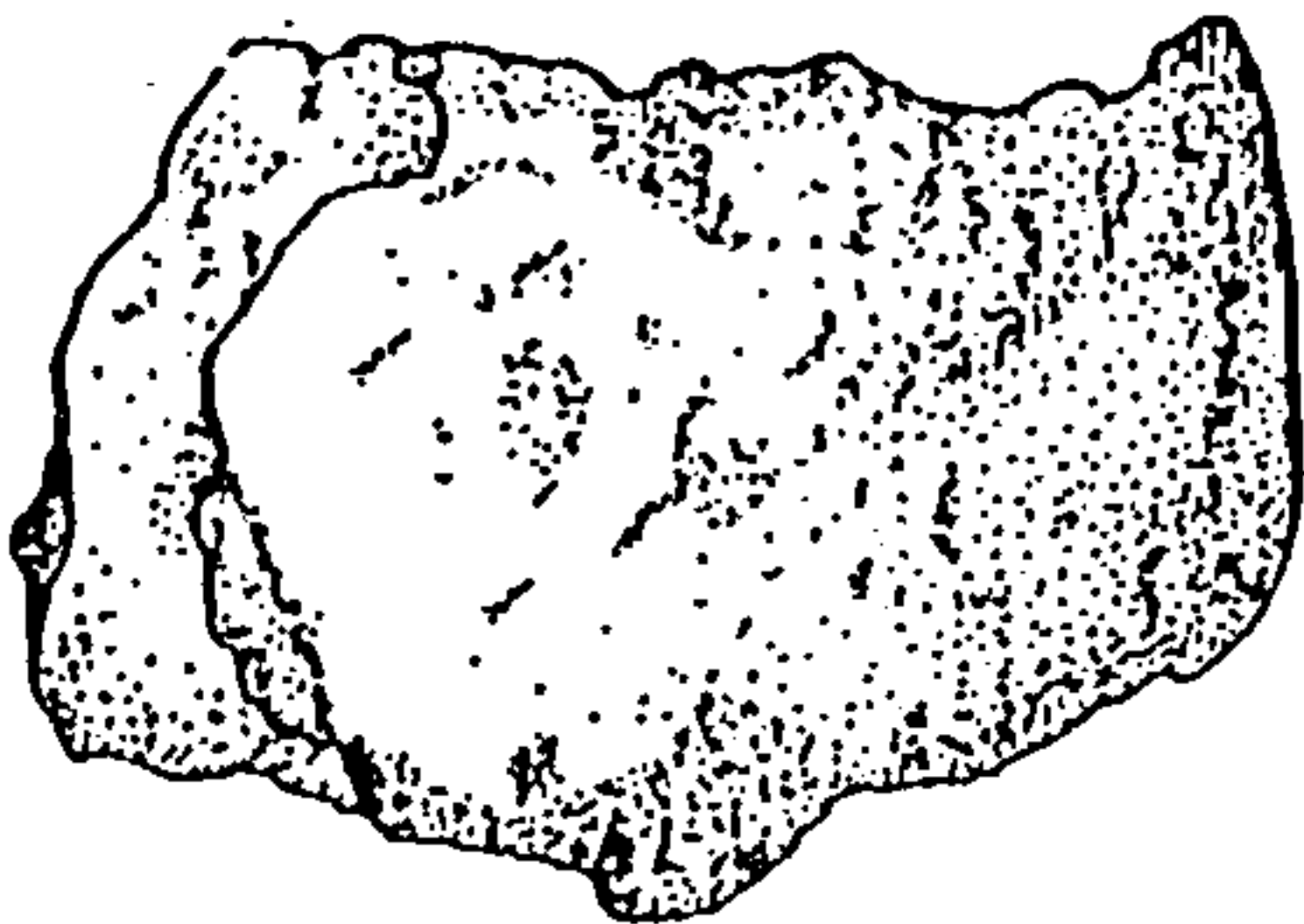
23/31



23/32



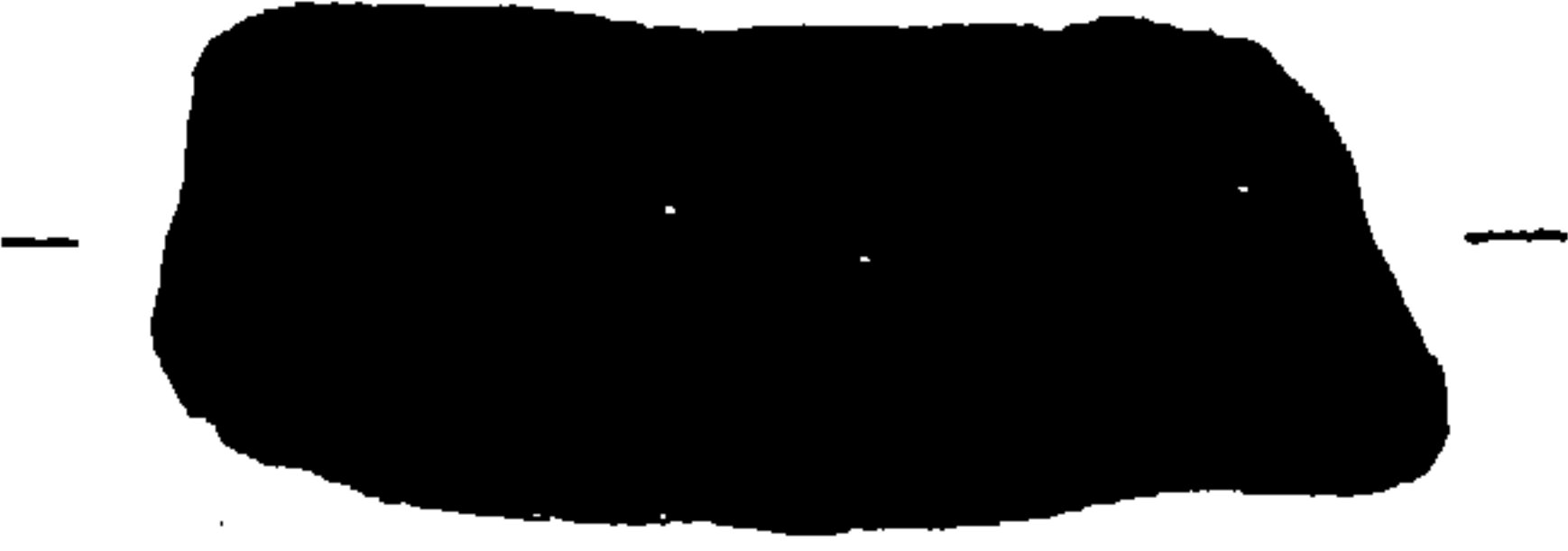
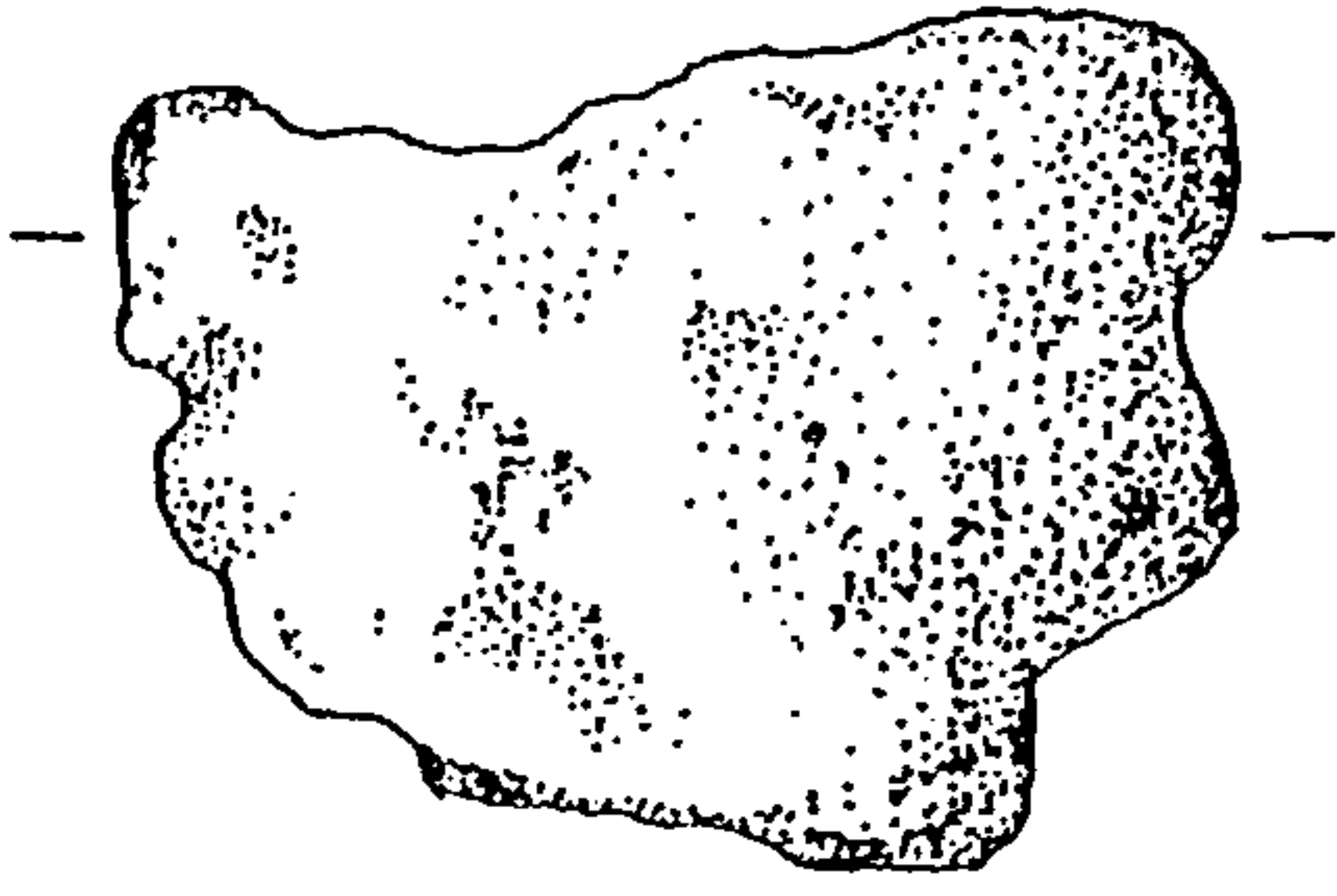
23/33



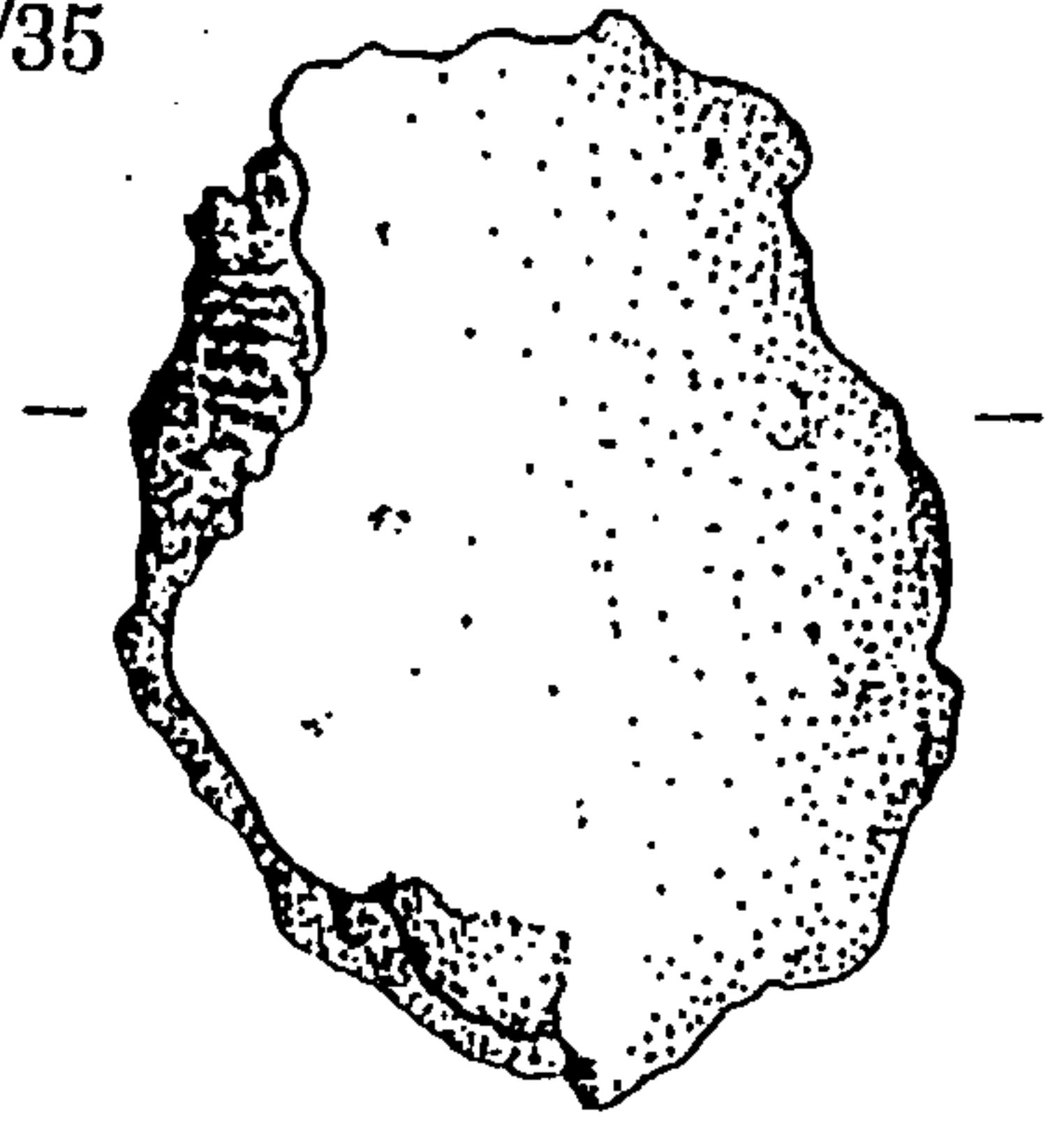
0 2cm

Fig. 93: The Whitstable Hoard (Ref. No. 23): Casting Debris and Ingot Metal (i)

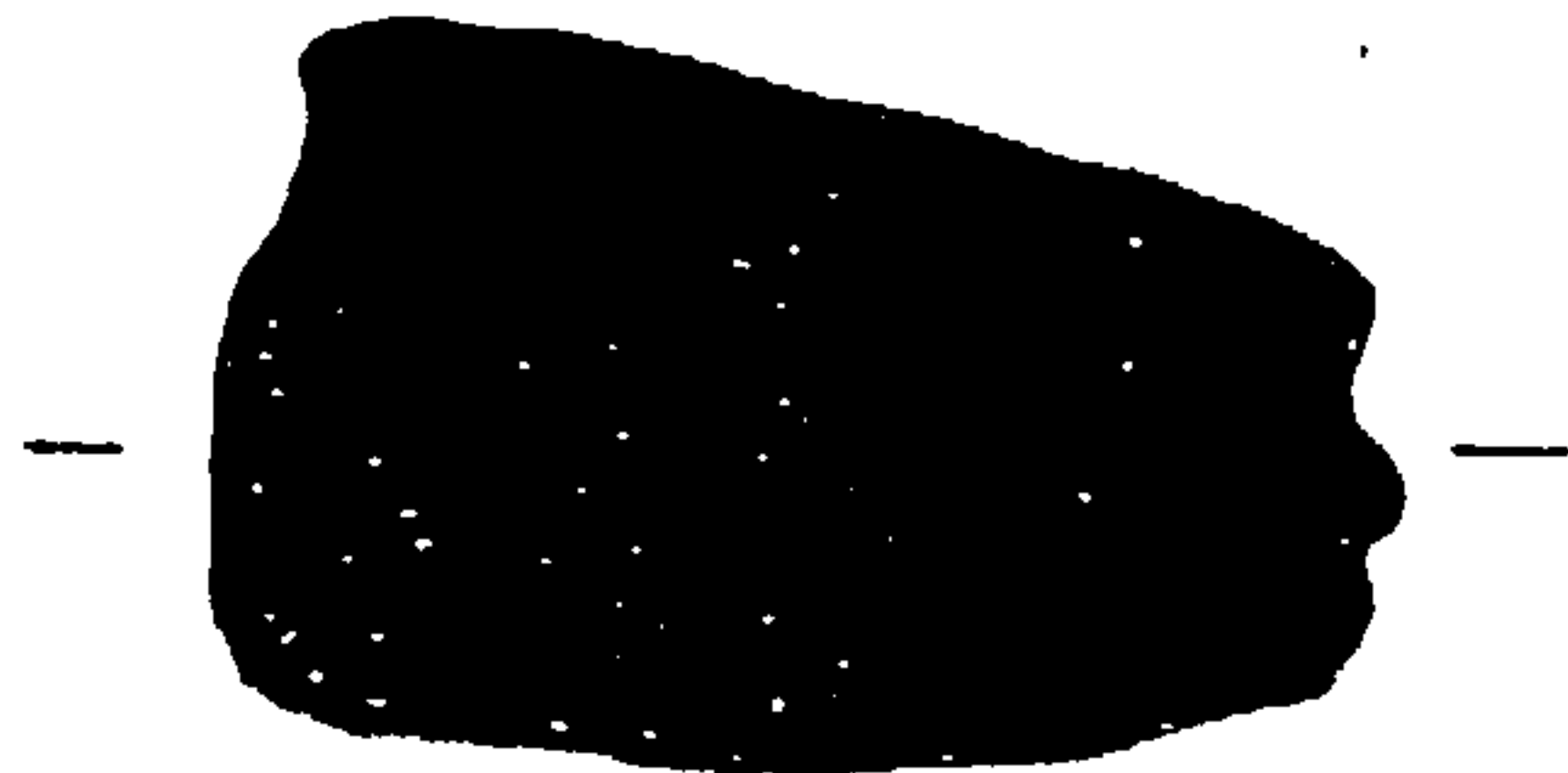
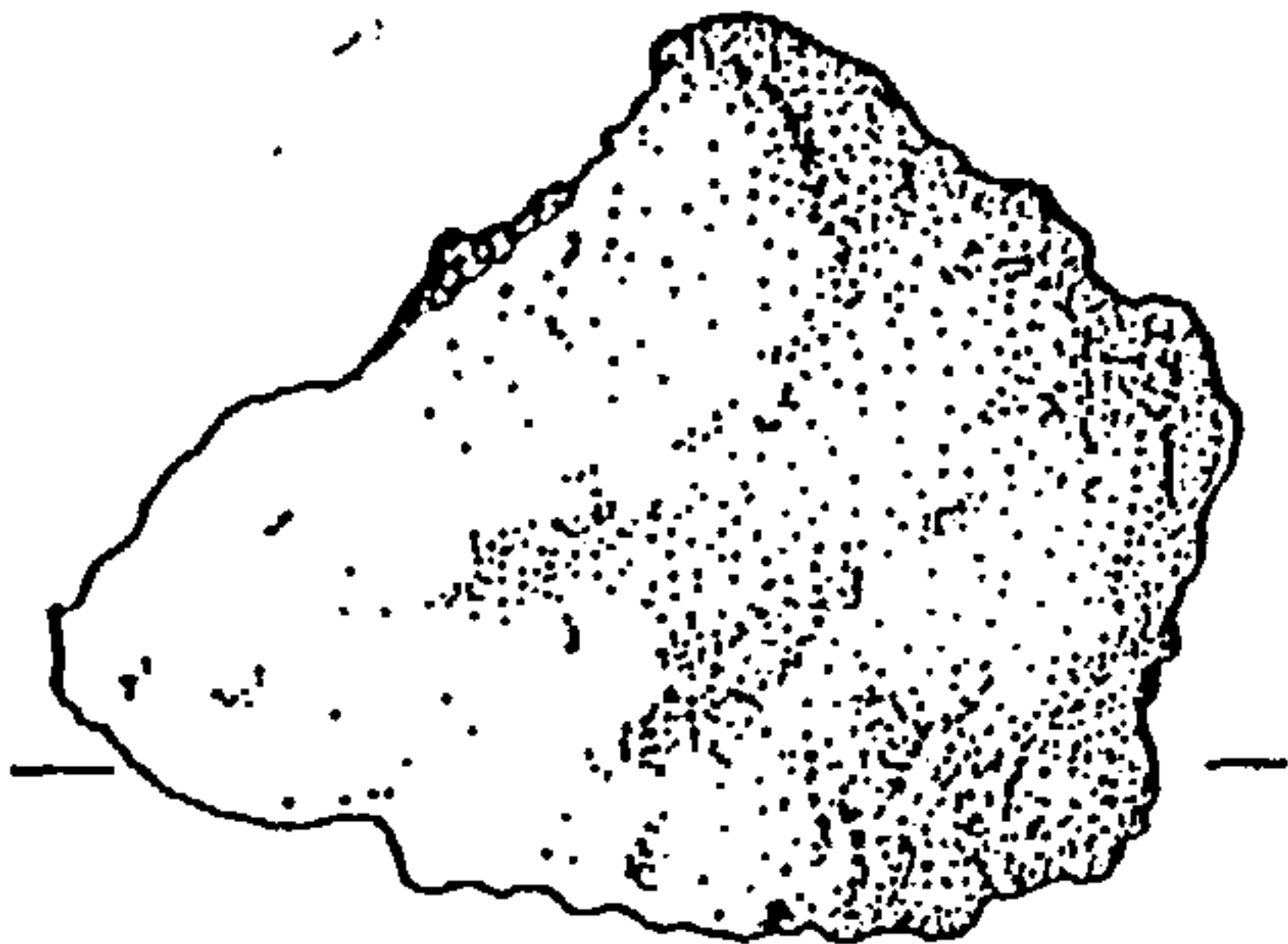
23/34



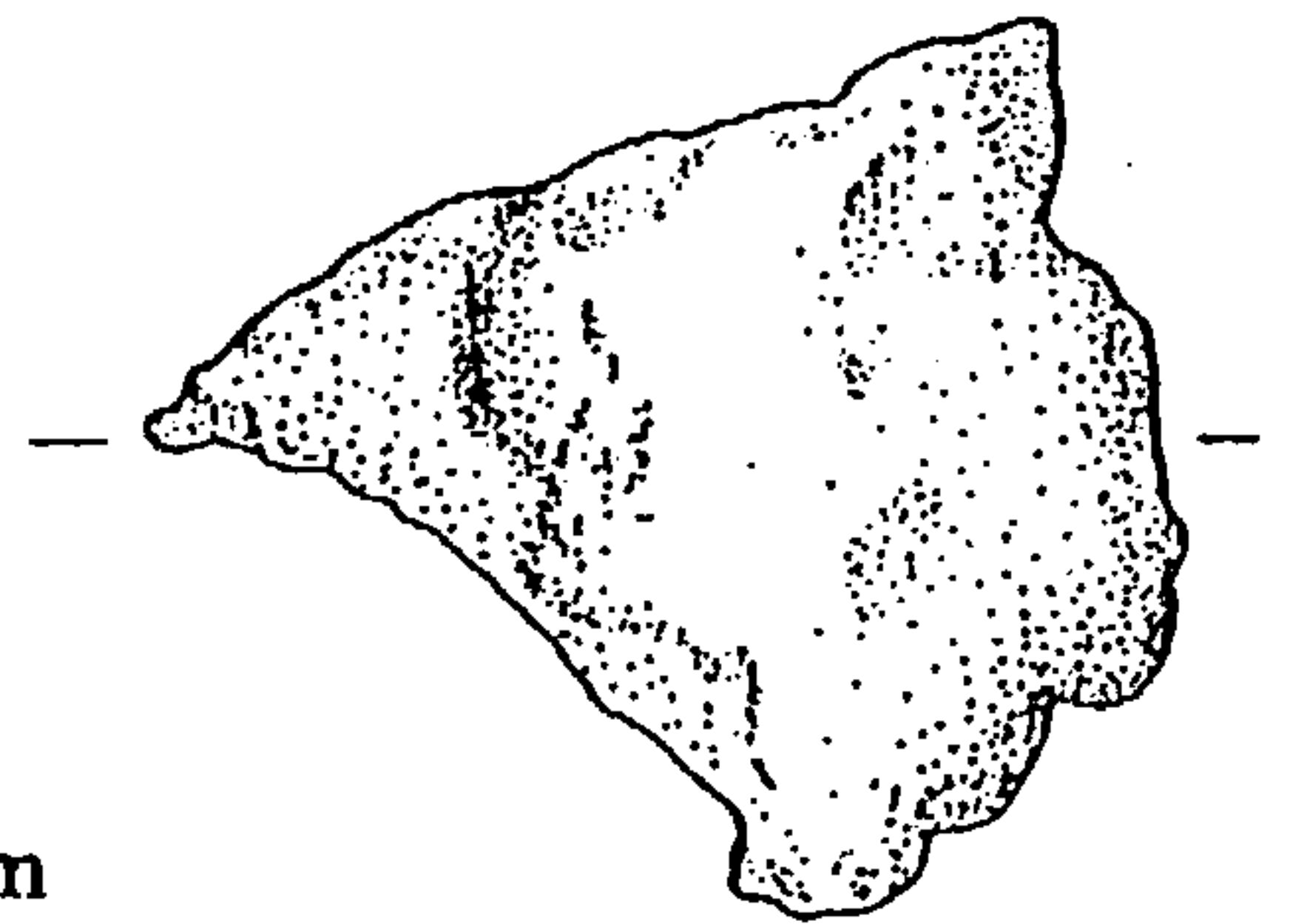
23/35



23/36



23/37



0 2cm

23/38

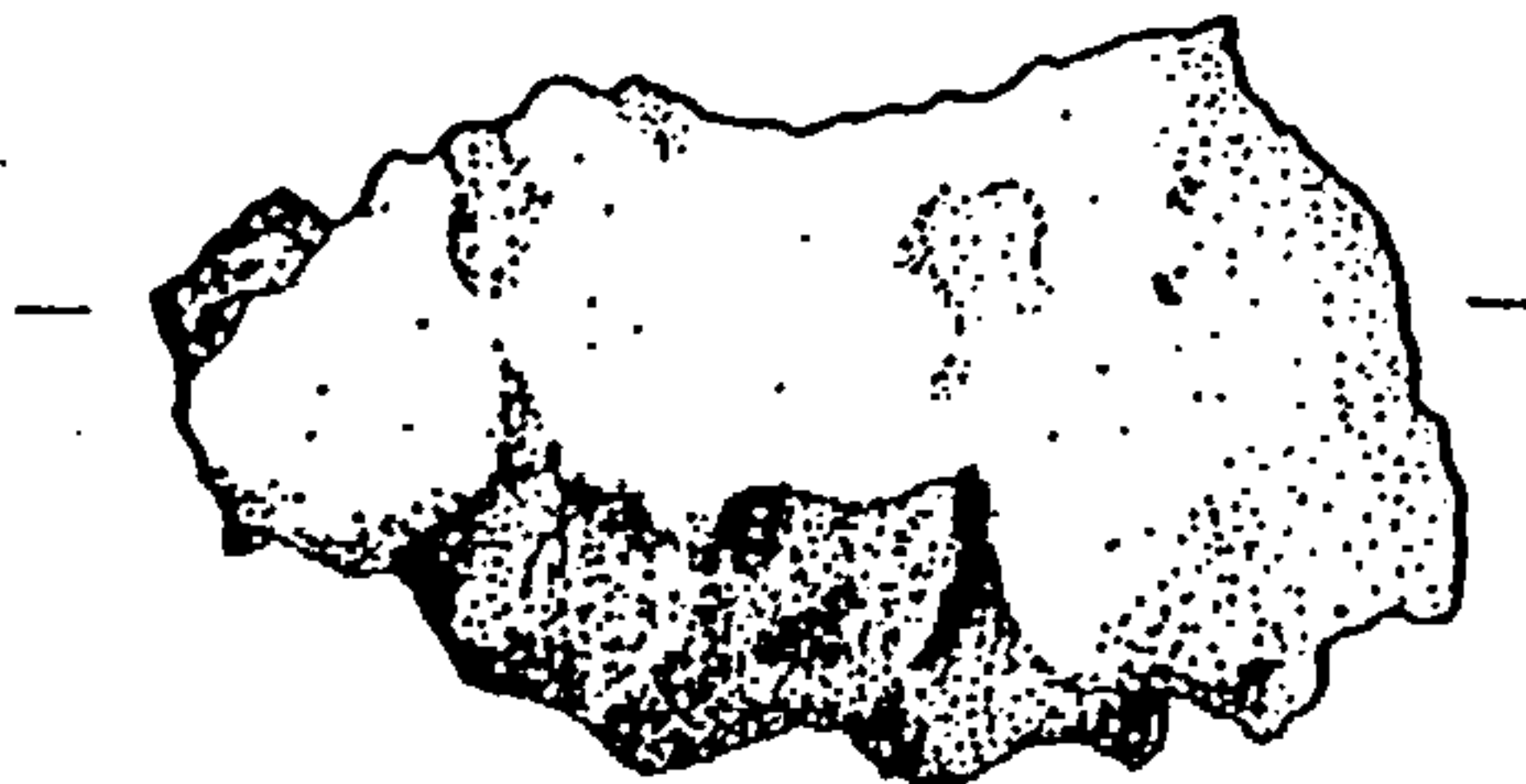


Fig. 94: The Whitstable Hoard (Ref. No. 23): Ingot Metal (ii)

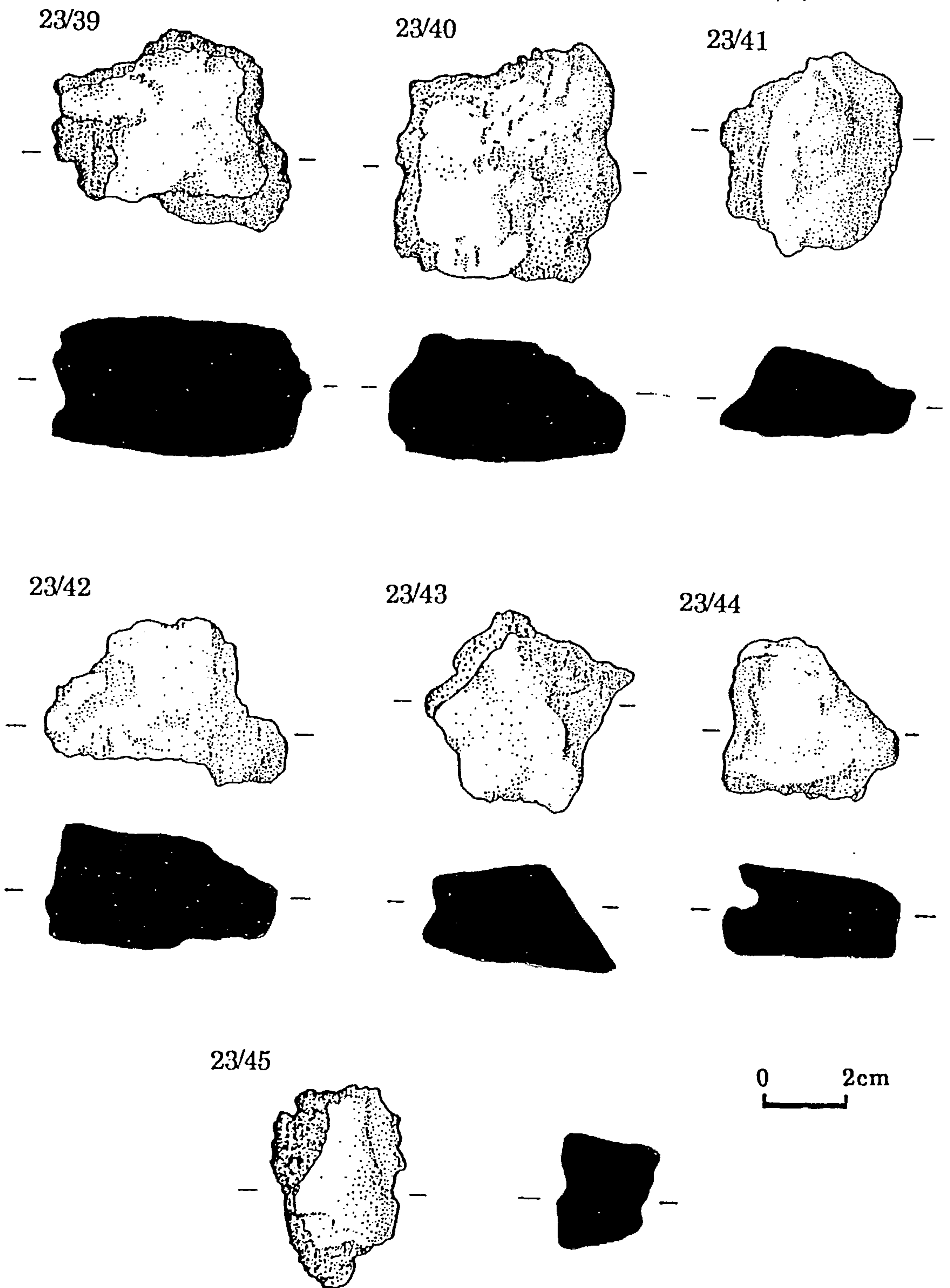
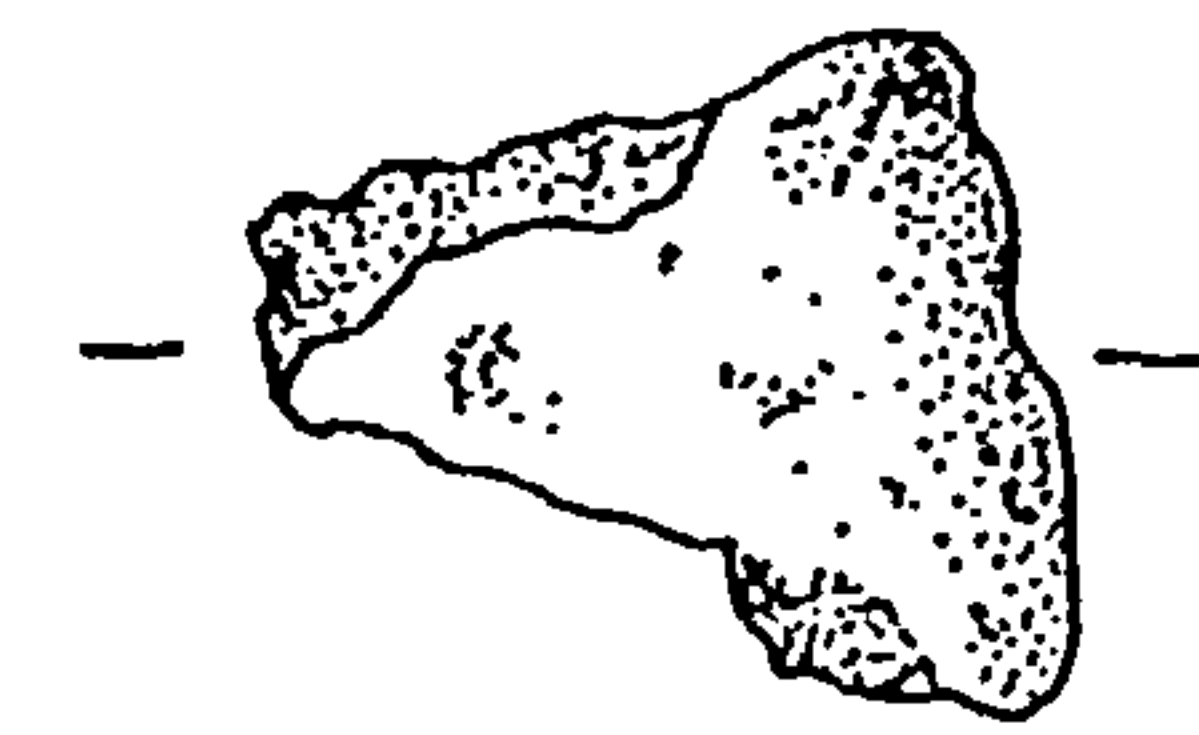
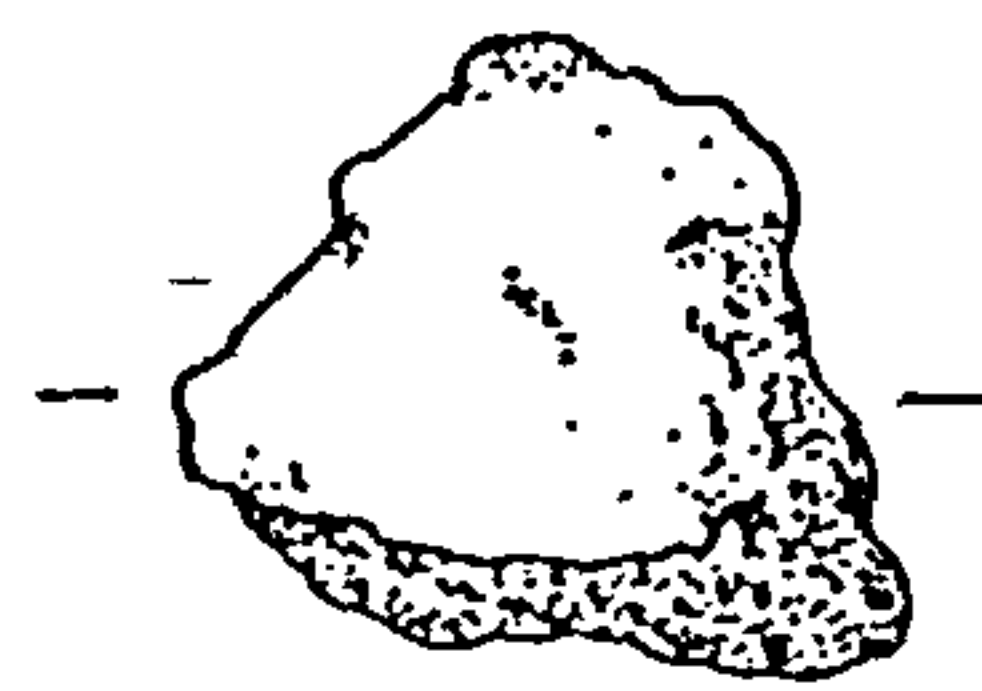


Fig. 95: The Whitstable Hoard (Ref. No. 23): Ingot Metal (iii)

23/46



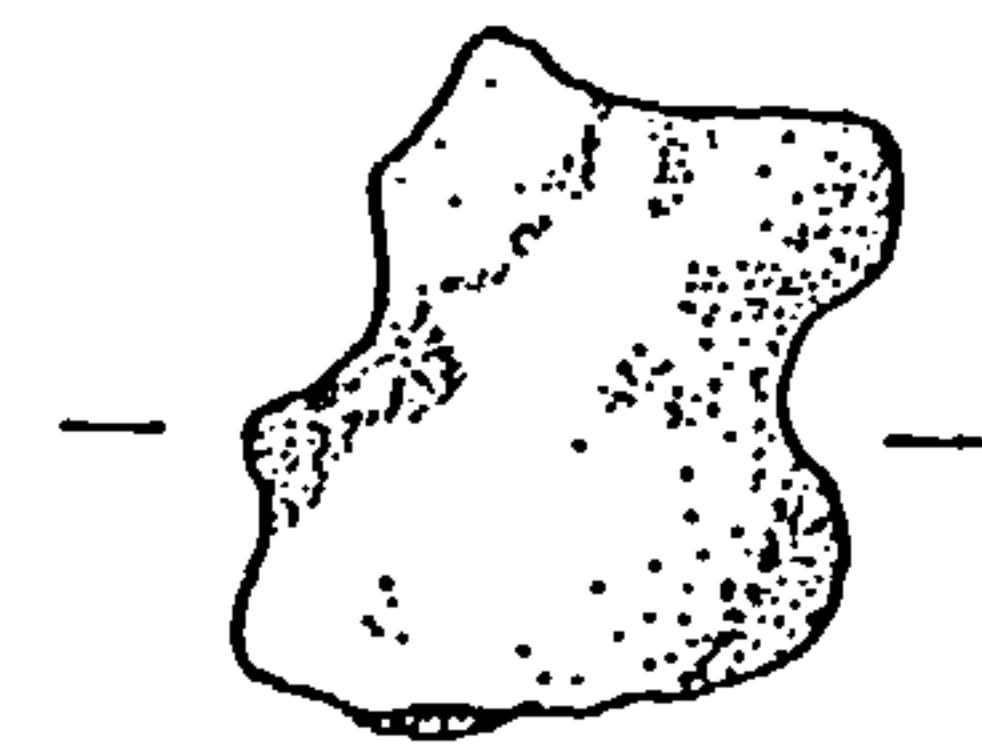
23/47



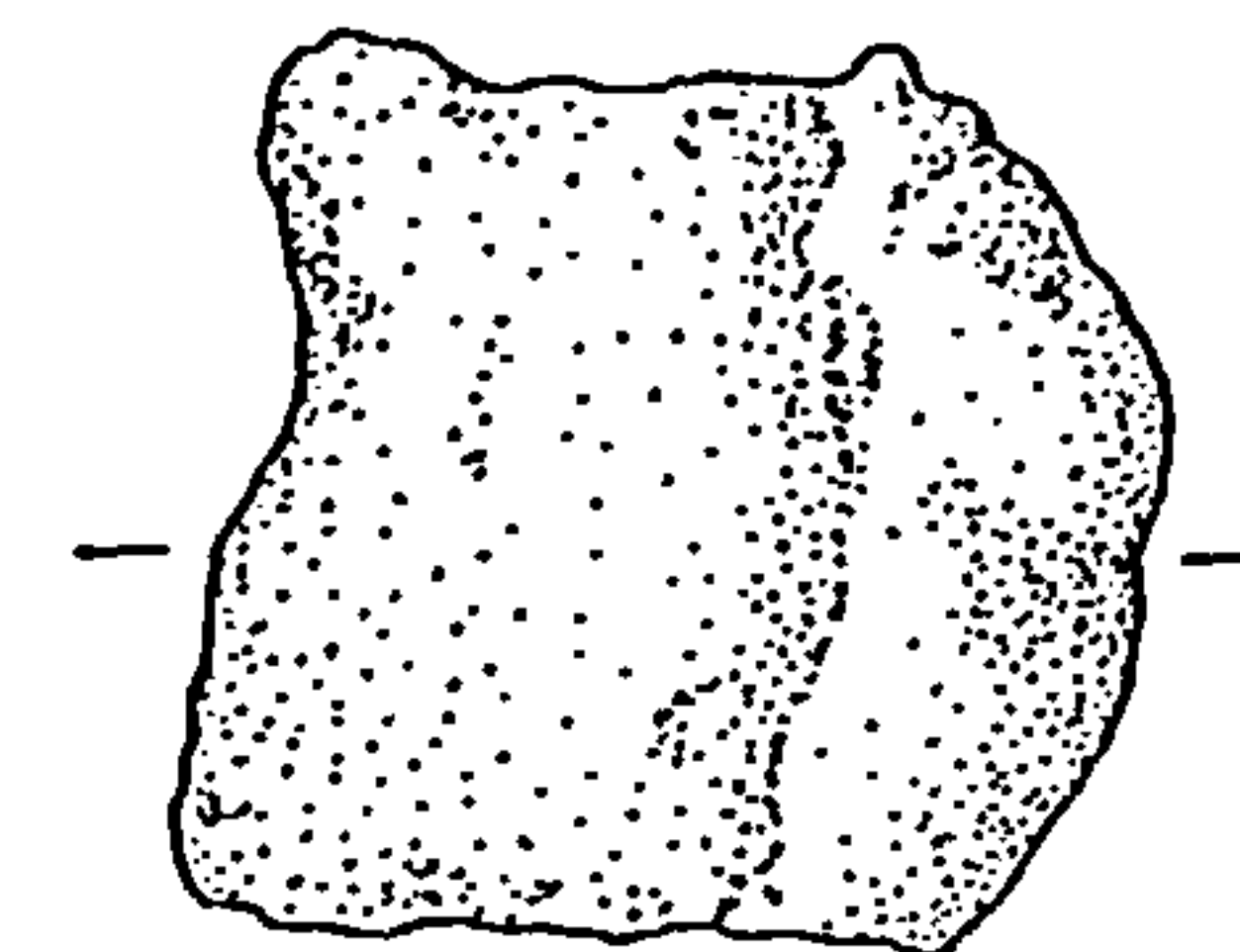
23/48



23/49



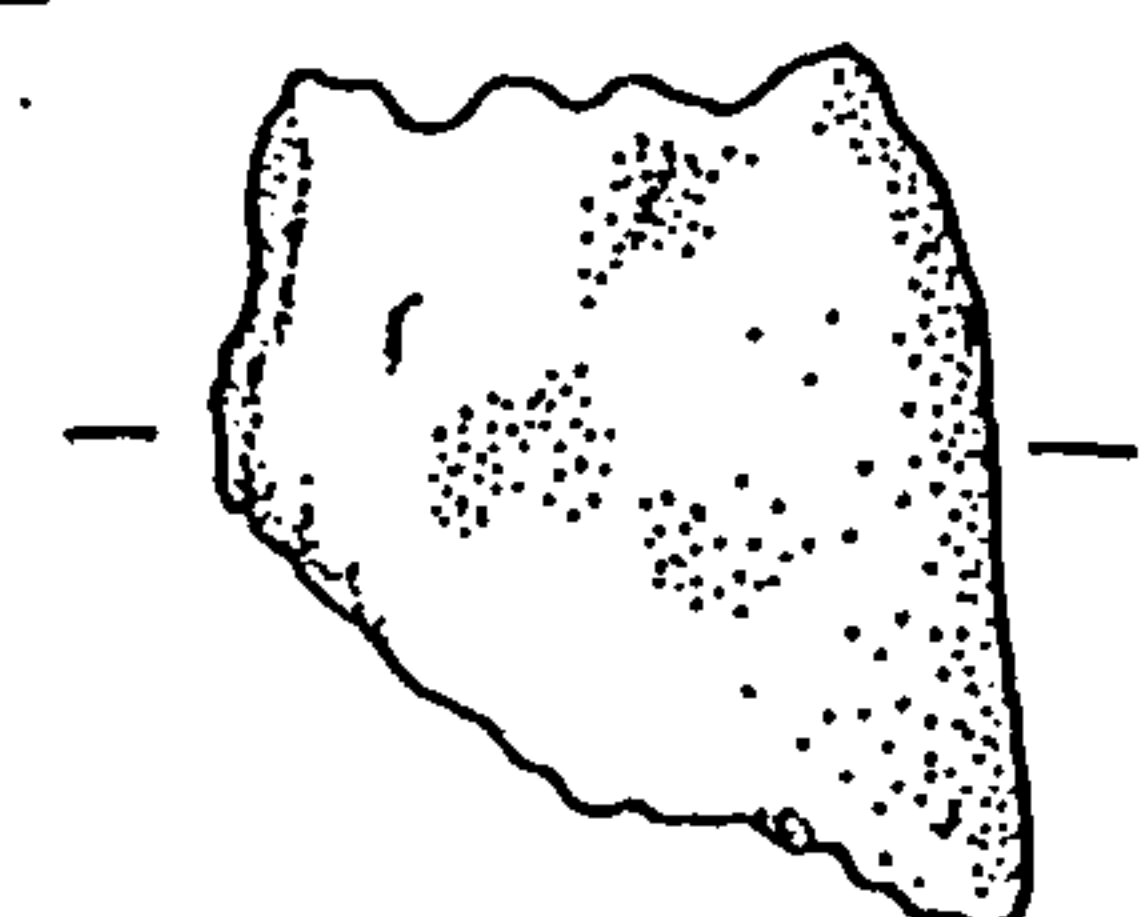
23/50



0 2cm



23/51



23/52

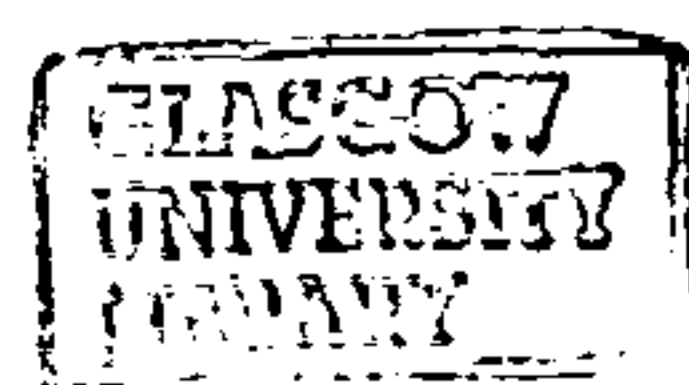


Fig. 96: The Whitstable Hoard (Ref. No. 23): Ingot Metal (iv)