



UvA-DARE (Digital Academic Repository)

Tissue ablation and gas formation of two excimer laser systems: an in vitro evaluation on porcine aorta

Appelman, J.E.A.; Piek, J.J.; Verhoofstad, G.G.A.M.; Gijsbers, G.H.M.; van Gemert, M.J.C.

DOI

[10.1002/\(SICI\)1096-9101\(1996\)18:2<197::AID-LSM11>3.0.CO;2-5](https://doi.org/10.1002/(SICI)1096-9101(1996)18:2<197::AID-LSM11>3.0.CO;2-5)

Publication date

1996

Published in

Lasers in Surgery and Medicine

[Link to publication](#)

Citation for published version (APA):

Appelman, J. E. A., Piek, J. J., Verhoofstad, G. G. A. M., Gijsbers, G. H. M., & van Gemert, M. J. C. (1996). Tissue ablation and gas formation of two excimer laser systems: an in vitro evaluation on porcine aorta. *Lasers in Surgery and Medicine*, 18, 197-205.
[https://doi.org/10.1002/\(SICI\)1096-9101\(1996\)18:2<197::AID-LSM11>3.0.CO;2-5](https://doi.org/10.1002/(SICI)1096-9101(1996)18:2<197::AID-LSM11>3.0.CO;2-5)

General rights

It is not permitted to download or to forward/distribute the text or part of it without the consent of the author(s) and/or copyright holder(s), other than for strictly personal, individual use, unless the work is under an open content license (like Creative Commons).

Disclaimer/Complaints regulations

If you believe that digital publication of certain material infringes any of your rights or (privacy) interests, please let the Library know, stating your reasons. In case of a legitimate complaint, the Library will make the material inaccessible and/or remove it from the website. Please Ask the Library: <https://uba.uva.nl/en/contact>, or a letter to: Library of the University of Amsterdam, Secretariat, Singel 425, 1012 WP Amsterdam, The Netherlands. You will be contacted as soon as possible.

Tissue Ablation and Gas Formation of Two Excimer Laser Systems: An In Vitro Evaluation on Porcine Aorta

Yolande E.A. Appelman, MD, Jan J. Piek, MD,
Geert G.A.M. Verhoofstad, MSc, Geert H.M. Gijsbers, PhD, and
Martin J.C. van Gemert, PhD

Department of Cardiology (Y.E.A.A., J.J.P.) and Laser Center (G.G.A.M.V., G.H.M.G., M.J.C.v.G.), Academic Medical Center, 1105 AZ Amsterdam, The Netherlands

Background and Objective: The relationship between tissue ablation volume and the formation of insoluble gas of the currently available excimer laser systems is unknown. This aspect was evaluated in two excimer laser systems.

Study Design/Materials and Methods: We measured tissue ablation volume and gas production of two excimer laser systems (308 nm) on porcine aortic tissue immersed in saline (the CVX-300 using 1.4 and 1.7 mm laser catheters and the Dymcr 200+ using 1.3, 1.3z and 1.6 mm laser catheters).

Results: Tissue ablation volume and gas production increased proportionally with the applied energy fluence, ranging from 30–60 mJ/mm². The gas production per unit of ablated tissue volume of the 1.4 mm laser catheter was significantly higher than the 1.3 mm laser catheter (mean difference +117%, 95% CI from +64% till +188%, $P < 0.001$). The gas production of the 1.7 mm laser catheter was higher than the 1.6 mm laser catheter (mean difference +70%, 95% CI from +28% till +126%, $P < 0.001$). The 1.3z mm laser catheter demonstrated more gas production than the 1.3 mm laser catheter (mean difference +123%, 95% CI from +68% till +196%, $P < 0.001$).

Conclusion: The results of our study indicate that excimer laser with the use of the CVX-300 laser system results in significantly higher gas production than the Dymcr 200+ laser system, which can be markedly reduced by lowering the applied energy fluence. The 1.3z laser catheter constitutes an exception, showing similar characteristics as the CVX-300 laser catheters.

© 1996 Wiley-Liss, Inc.

Key words: excimer laser, tissue ablation, gas production, in vitro

INTRODUCTION

Excimer laser coronary angioplasty (ELCA) enables lumen enlargement of coronary narrowings by tissue ablation [1–7]. The laser system used in ELCA is a xenon chloride excimer laser, which operates at a 308 nm wavelength and is characterized by a high absorption grade in tissue, resulting in a small penetration depth [1–7]. These physical properties enable tissue ablation with high precision, and therefore excimer laser is considered to be the preferable laser system in relatively small size coronary arteries. Recent

studies have indicated that tissue ablation in excimer laser is accompanied by the creation of fast expanding and collapsing water vapour bubbles and insoluble gas formation [8–12]. These phenomena may contribute to mechanical damage of the coronary vascular wall [9–11], inducing dissections that are frequently observed [14–20%] after ELCA [13–18,22,23]. In spite of these im-

Accepted for publication November 28, 1994.

Address reprint requests to Yolande E.A. Appelman, Academic Medical Center, Meibergdreef 9, 1105 AZ Amsterdam, The Netherlands.

TABLE 1. Characteristics of Excimer Laser Catheters

	Dymer 200 +			CVX-300	
	1.3	1.6	1.3z	1.4	1.7
Laser catheter (mm)	1.3	1.6	1.3z	1.4	1.7
nr.fibers	116	200	147	108	136
Fiber cross-sectional area (mm ²)	0.24	0.42	0.31	0.29	0.42

portant clinical implications, there is limited information regarding the relationship between the ablative capacity and the formation of insoluble gas of the currently available excimer laser systems. It is the purpose of this study to evaluate the two most frequently used excimer laser systems for coronary angioplasty regarding these aspects in an in vitro setting.

MATERIALS AND METHODS

Two xenon chloride (XeCl) excimer laser systems (308 nm) were evaluated (Table 1). One system was the Dymer 200+ (Advanced Interventional Systems, Irvine, CA) using multifiber laser catheters of 1.3 mm (1.3 and 1.3z) and 1.6 mm, with a pulse duration of 220 ns and pulse frequency of 20 Hz. The 1.3z laser catheter is the successor of the 1.3 mm laser catheter, with an increased number of fibers and therefore a larger total ablational area. The other system was the CVX-300 (Spectranetics, Colorado Springs, CO) using multifiber laser catheters of 1.4 mm and 1.7 mm with a pulse duration of 135 ns and a pulse frequency of 25 Hz. (The correctness of the diameter size of the catheters, provided by the manufacturer, was verified using a ruler.) All experiments were performed at room temperature and ambient air pressure. No special measures were taken to keep the temperature and pressure constant.

Tissue ablation volumes were determined on defrosted porcine aortic tissue immersed in saline. This tissue was used to provide a uniform and reproducible model for vascular tissue. Saline, which does not absorb the UV light, was used to avoid a possible interference of light absorption in other immersion media such as blood. Gas production was determined in whole blood and in defrosted porcine aortic tissue immersed in saline.

The CVX-300 laser system delivers a computer-controlled pulse train of 5 seconds at a recommended pulse frequency of 25 Hz, providing a pulse train of 125 pulses. The recommended Dymer 200+ pulse frequency is 20 Hz; conse-

quently, we used a pulse train of 6.25 s in order to deliver a comparable pulse train of 125 pulses.

Tissue ablation volume and gas production were assessed at stepwise increased energy fluence levels ranging from 30–60 mJ/mm² (45–60 mJ/mm² is usually applied in the clinical setting). This protocol was repeated ten times for each catheter in separate experiments using another aorta tissue sample. In order to assess the trend of gas production in whole blood, the experiments were repeated only twice for the each catheter, except for the 1.3z laser catheter, for which only one gas production measurement at each energy fluence was performed.

Assessment of Ablation Volume

The advancement of a laser catheter in porcine aortic tissue was measured by means of the model depicted in Figure 1. The laser catheter was fixed in a shaft and the distal part was in contact with the tissue specimen immersed in saline. A constant pressure per surface area was provided by using a weight of 6 grams for the 1.3, 1.3z, and 1.4 mm laser catheters and 9 grams for the 1.6 and 1.7 mm laser catheters. The shaft and laser catheters could move freely in the vertical direction and were kept in balance by means of a counterweight. The vertical movement of the catheter during excimer laser exposure was recorded by a position transducer (7/24 DCDT-250, Hewlett Packard) connected to a data recorder (Keithley System 570). The tissue ablation volume per pulse was defined as the product of the advancement per pulse, determined as the total penetration divided by 125 pulses, and the catheter cross sectional area (mm³/pulse).

Assessment of Gas Production

The gas production was determined in a chamber according to a design by Davis et al. [19] as demonstrated in Figure 2. The laser catheter was inserted into this airtight chamber that was connected to a glass capillary, which could contain a volume of 0.66 μ l per mm length. The aortic tissue specimen was put on a table fixed on a spring. The laser catheters were positioned

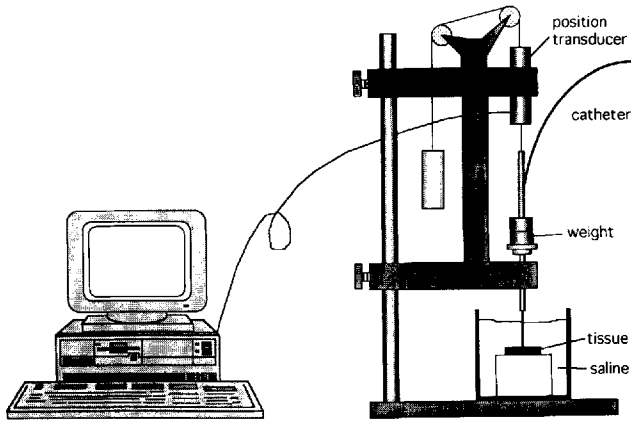

Fig. 1. Experimental model for tissue ablation volume measurements. An excimer laser catheter (308 nm) is fixed in a shaft and is in contact with the porcine aortic tissue immersed in saline. Different weights can be added to the shaft to provide a constant pressure. The vertical movement of the laser catheter is recorded by a position transducer connected to a personal computer.

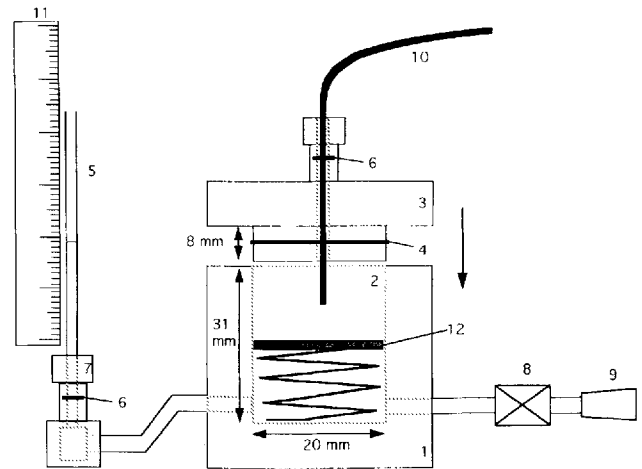

Fig. 2. Design by Davis et al. [19] of an airtight chamber filled with saline or blood used for gas production measurements with excimer laser catheters (308 nm). 1: perspex cylinder, 2: hole, 3: perspex cap, 4 and 6: rubber rings, 5: glass capillary, 7: screw cap, 8: valve, 9: attachment for syringe, 10: fiber or catheter, 11: ruler, 12: spring with table. The gas production is measured by an increase of the saline or blood level in the glass capillary.

against the tissue specimen with a constant pressure using a force equivalent to a weight of 6 grams for the small-size laser catheters (1.3, 1.3z and 1.4 mm) and 9 grams for the larger size laser catheters (1.6 and 1.7 mm). The chamber was filled with saline by means of a second tube connected to the chamber. In the same way the chamber was filled with blood for the gas measurements in this medium. These latter experiments were performed without tissue specimen. Gas production during excimer laser exposure was measured by the increase of the saline or blood level in the capillary, which was recorded by a video camera (Sony AVS-D7CE). A tele-macro lens (Canon TV zoom lens V6 \times 16–100mm 1:1.9) was used for optimal magnification of the ruler. The gas production per pulse after each exposure was expressed both in volume per pulse (unit μ l) and in volume per unit of fiber crosssectional area (unit μ l/mm²).

Finally, the gas production related to the ablation volume was expressed as a function of the energy fluence.

Statistical Analysis

The relationship between tissue ablation or gas production with different size laser catheters was determined by covariance analysis using the natural logarithms of these variables with energy fluence as a covariate. The slopes of the fitted regression lines neither differed significantly be-

tween catheters nor between tissue ablation and gas production. This allowed the use of a regression line with one common slope for the analysis. As a consequence, estimates of ratios between catheters are reported without specifying an energy fluence level. We used a statistical program package BMDP to determine the means and standard errors from which we calculated 95% confidence intervals. A *P* value < 0.05 was considered statistically significant.

RESULTS

Ablation Volume

Figure 3 presents the ablation volume per pulse as a function of energy fluence. The tissue ablation volume induced by the 1.3 and 1.4 mm laser catheters was smaller than the tissue ablation volume induced by the 1.6 and 1.7 mm laser catheters. Tissue ablation volume induced by the 1.3z laser catheter demonstrated intermediate values. The tissue ablation volume of the 1.4 mm laser catheter was significantly higher than the 1.3 mm laser catheter (mean difference +12%, 95% confidence interval (CI) from +1% till +26%, *P* = 0.043). The tissue ablation volume of the 1.7 mm laser catheter was comparable with the 1.6 mm laser catheter (mean difference -9%, 95% CI from -19% till +3%, not significant).

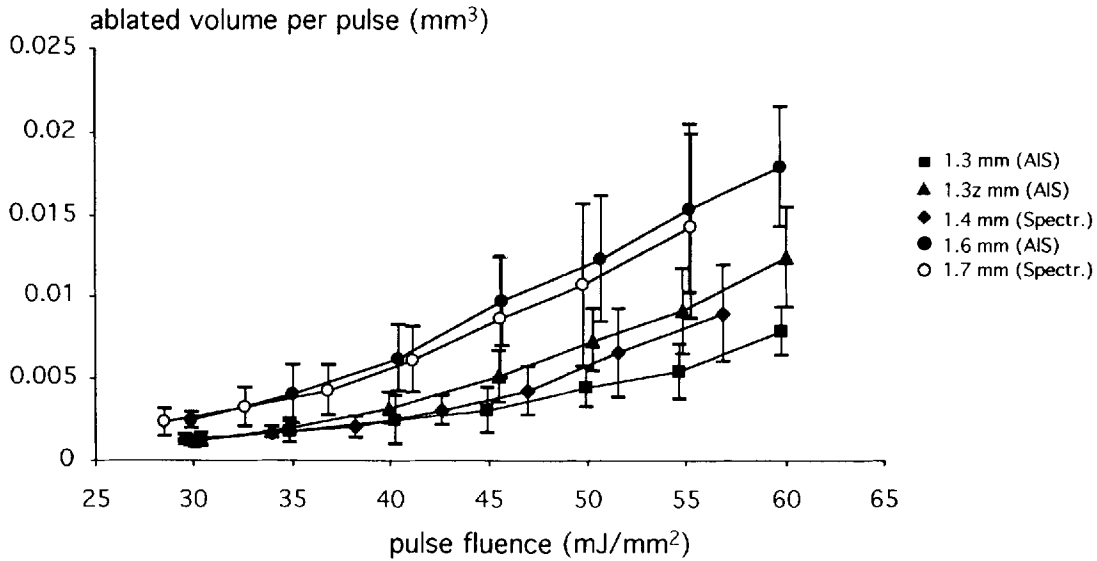

Fig. 3. Relationship between tissue ablation volume and energy fluence of the different laser catheters. Measurements on porcine aortic tissue immersed in saline.

Furthermore, the tissue ablation volume of the 1.3z mm laser catheter was significantly higher than the 1.3 mm laser catheter (mean difference +37%, 95% CI from +24% till +56%, $P < 0.001$).

Gas Production

Figure 4 illustrates the absolute gas production per pulse as a function of energy fluence. The 1.3 and 1.4 mm laser catheters demonstrated a lower gas production than the 1.6 and 1.7 mm laser catheters. The 1.3z mm laser catheter demonstrated an intermediate gas production. The gas production of the 1.4 mm laser catheter was significantly higher than the 1.3 mm laser catheter (mean difference +142%, 95% CI from +86% till +215%, $P < 0.001$) as well as the 1.7 mm laser catheter compared to the 1.6 mm laser catheter (mean difference +54%, 95% CI from +18% till +101%, $P < 0.001$). Furthermore, the gas production of the 1.3z mm laser catheter was significantly higher than the gas production of the 1.3 mm laser catheter (mean difference +210%, 95% CI from +139% till +303%, $P < 0.001$).

Figure 5 shows the average gas production per fiber cross-sectional area per pulse in relation to energy fluences ranging from 30 to 60 mJ/mm². The gas production per area of the 1.4 mm laser catheter was significantly higher than the gas production per area of the 1.3 mm laser catheter (mean difference +100%, 95% CI from +54% till 161%, $P < 0.001$). The same is true for the 1.7 mm

laser catheter and the 1.6 mm laser catheter (mean difference +54%, 95% CI +18% till +101%, $P < 0.001$). The gas production per area of the 1.3z laser catheter is significantly higher than the gas production per area of the 1.3 mm laser catheter (mean difference +140%, 95% CI from 85% till 212%, $P < 0.001$).

Figure 6 depicts the calculated gas production per unit of ablated tissue volume per pulse in relation to the applied energy fluence. The gas production per ablated volume of the Dyrer 200 + 1.3 and 1.6 mm laser catheters was comparable. The gas production per ablated volume of the CVX-300 1.4 and 1.7 mm laser catheters was also comparable, but significantly higher than the gas production per ablated volume for the Dyrer 200 + 1.3 and 1.6 mm laser catheters respectively. (1.4 vs. 1.3 mm laser catheter, mean difference +117%, 95% CI from +64% till +188%, $P < 0.001$); (1.7 vs. 1.6 mm laser catheter, mean difference +70%, 95% CI from +28% till +126%, $P < 0.001$). The 1.3z laser catheter demonstrates a significant higher gas production per ablated volume compared to the 1.3 mm laser catheter (mean difference +123%, 95% CI from +68% till +196%, $P < 0.001$).

The absolute gas production per pulse of the measurements in whole blood as a function of energy fluence is shown in Figure 7, demonstrating an increase in gas production at energy fluences ranging from 30–60 mJ/mm².

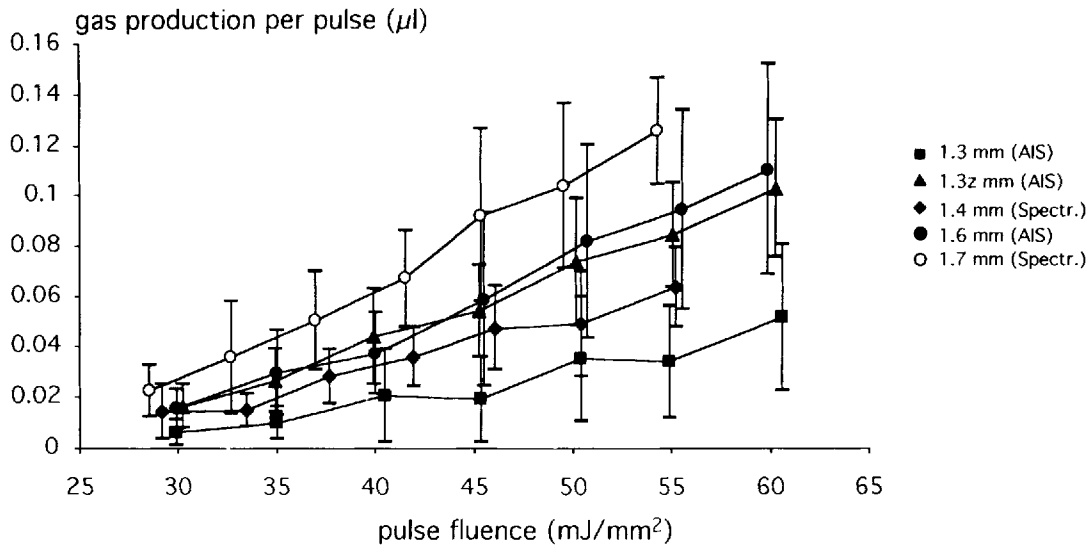

Fig. 4. Relationship between gas production and energy fluence of the different laser catheters. Measurements on porcine aortic tissue immersed in saline.

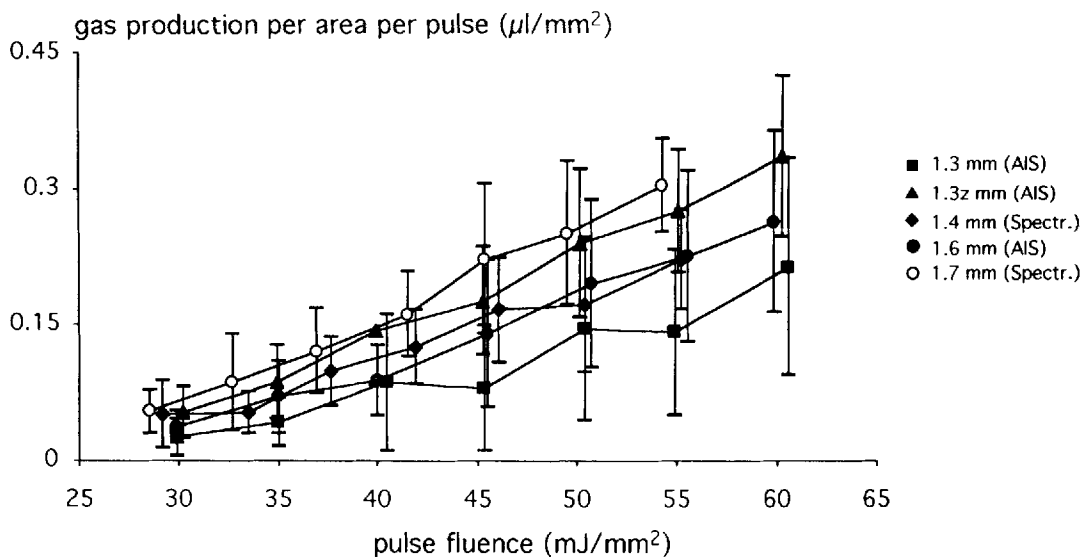

Fig. 5. Relationship between gas production per fiber cross-sectional area and energy fluence of the different laser catheters. Measurements on porcine aortic tissue immersed in saline.

DISCUSSION

Tissue Ablation Volume

The results of our study indicate that tissue ablation volume increases with the size of the laser catheter and the applied energy fluence (Fig. 3). It is conceivable that the increase in tissue ablation of the larger size laser catheters relates to an increase in fiber cross-sectional area (Table 1). The dependency of the tissue ablation volume in relation to the total fiber cross-sectional area is supported by the observations using a 1.3z mm

laser catheter. Although this catheter is a size similar to the 1.3 mm laser catheter, it induces significantly more tissue ablation. The marked dependency of ablation volume on the applied energy fluence has not been reported previously. Nevertheless, these observations are important as our data indicate a marked increase (10–50%) in ablation volume at energy fluences ranging from 45–60 mJ/mm² usually applied in the clinical setting. These observations cannot be extrapolated to the clinical setting without any reserve,

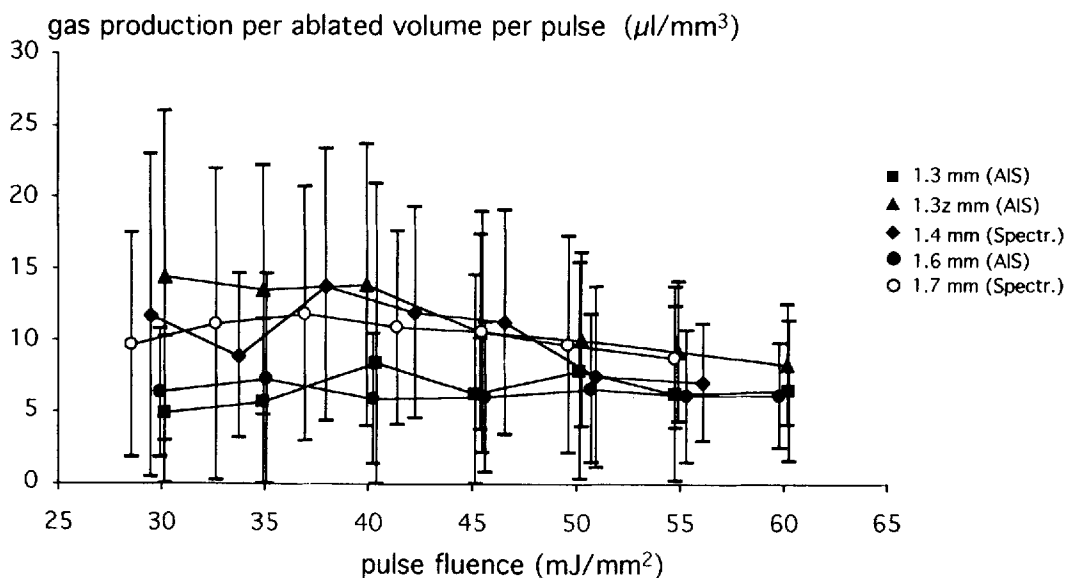

Fig. 6. Relationship between gas production per unit of ablated volume and energy fluence of the different laser catheters. Measurements on porcine aortic tissue immersed in saline.

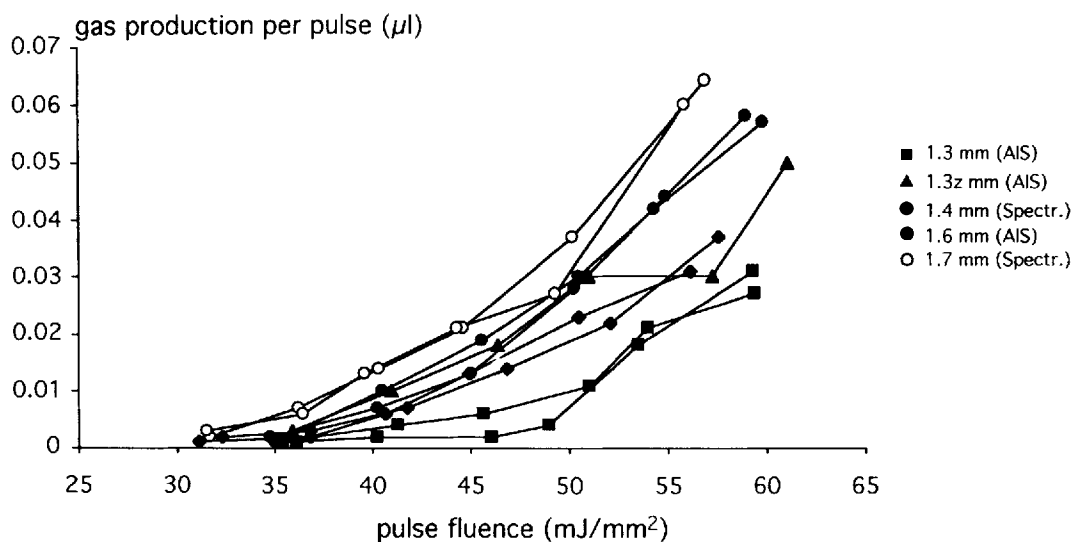

Fig. 7. Relationship between gas production and energy fluence of the different laser catheters. Measurements in whole blood.

as our experiments were performed under controlled in vitro conditions.

Gas Production

In accordance with the observations regarding tissue ablation volume, the gas production increases with the size of the laser catheter and energy fluence.

The absolute gas production as a function of energy fluence (Fig. 4) demonstrates that the 1.4 mm laser catheter generates more insoluble gas than the 1.3 mm laser catheter and the 1.7 mm

laser catheter more than the 1.6 mm laser catheter. There are several reasons that may explain the observed differences in gas production between the two laser systems. First, the fiber cross-sectional area of the 1.4 mm laser catheter is $\sim 20\%$ larger than the fiber cross-sectional area of the 1.3 mm laser catheter (Table 1). This could explain the difference in gas production between these two laser catheters. However, the 1.7 and 1.6 mm laser catheters demonstrate significant differences in gas production despite the similar fiber cross-sectional area. Furthermore, the re-

sults depicted in Figure 5 indicate that this is not sufficient to explain the observed differences between the Dymmer 200+ laser system and the CVX-300 laser system, as significant differences in gas production were observed after correction for the fiber crosssectional area.

Second, there is a difference in pulse frequency between the two laser systems. The application of a 25 Hz laser beam (CVX-300) compared to a 20 Hz laser beam (Dymmer 200+) may result in a difference in tissue temperature related to the relatively long thermal relaxation time of tissue [20,21]. However, this argument is speculative as we did not perform tissue temperature measurements simultaneously in our experiment.

Third, there is a difference in pulse duration. The CVX-300 laser system generates a laser beam with a pulse duration of 135 ns compared to the Dymmer 200+ laser system, which generates a laser beam with a pulse duration of 220 ns. At present it is unknown if these differences in physical characteristics may influence the gas production.

The gas production per unit of ablated volume (Fig. 6) shows that the 1.4 and 1.7 mm laser catheters have comparable gas production per volume. Furthermore, the gas production per ablated volume of the 1.3 and 1.6 mm laser catheters is also comparable but significantly lower than the CVX-300 laser catheters. In conjunction, these data indicate that the CVX-300 generates more insoluble gas during tissue ablation than the Dymmer 200+, although the precise mechanism, responsible for the observed differences between the two systems, remains unclear.

The 1.3z mm laser catheter, which is the successor of the 1.3 mm laser catheter, demonstrates a significantly increased gas production compared to the 1.3 mm laser catheter. This again might be related to the larger crosssectional area of the 1.3z mm laser catheter (Table 1).

The gas production per ablated volume of the 1.3z laser catheter is significantly higher than the gas production per ablated volume of the 1.3 mm laser catheter. In this respect, the 1.3z laser catheter, which operates in combination with Dymmer 200+, is an exception. The results of our study indicate that this laser catheter is more effective in tissue ablation than the 1.3 mm laser catheter, for which it was designed. However, this effect is accomplished at the expense of more insoluble gas formation, mimicking the characteristics of the CVX-300 laser catheters.

The same trend of gas production, as in por-

cine aortic tissue immersed in saline, can be observed by the gas production measured in whole blood in relation to energy fluence. The gas production in whole blood approximates half of the gas production of excimer laser applied on porcine aortic tissue immersed in saline. Although these data are only from a limited number of experiments, they demonstrate that using blood as a fluid medium the gas production increases at rising energy fluence. This in contrast to saline where no gas production is observed [12] as saline does not absorb the UV-light. Whole blood does absorb the UV-light; consequently, insoluble gas is formed.

Clinical Implications

Our present findings may have clinical implications. It has been shown that fast expanding and imploding water vapour bubbles generated during excimer laser pulses are responsible for the formation of micro-dissections of the vessel wall [9,10]. It is conceivable that insoluble gas, which is also created during a laser pulse and which can accumulate around the catheter tip, may enhance these micro-dissections. For example, 1 μ l of gas is equivalent to a spherical bubble of 1.2 mm. Based upon current insights, the vascular wall damage is in particular related to the water vapour bubble formation, and the contribution of the creation of insoluble gas formation remains speculative. The CVX-300 1.4 and 1.7 mm laser catheters exhibit a larger volume of gas per ablated volume than the Dymmer 200+ 1.3 and 1.6 mm laser catheters. Consequently, an increase in incidence of dissections would support the hypothesis that insoluble gas formation contributes to the vascular wall damage. Clinical data provided by the present ELCA-registries have reported a similar incidence and extent of coronary dissections as documented by coronary angiography using both systems [13,22–24]. However, coronary angiography is not sensitive for the detection of vascular wall dissections and have been demonstrated to be inferior to other diagnostic tools as intravascular ultrasound [25,26] or angiography [27,28]. Furthermore, the ELCA-registries have reported the frequent use of balloon angioplasty after ELCA that masks, inherent to its beneficial therapeutic effect on coronary dissections, the true incidence of these dissections after laser treatment. Consequently, the incidence of coronary vascular dissections after ELCA is at present unknown.

The most striking feature of the gas produc-

tion is a 5–10-fold increase on porcine aorta immersed in saline at energy fluences ranging from 30–60 mJ/mm². This phenomenon can be appreciated to a lesser extent in whole blood, although these data should be interpreted carefully because only a few experiments were performed in this medium. The application of higher energy fluences, as used in the clinical setting, will result in a more effective tissue ablation, however, at the expense of increased insoluble gas formation.

The results of our study clearly indicate two options to reduce the adverse effects of insoluble gas formation. Flushing with saline during ELCA will result in the removal of blood, thus reducing the contribution of gas production in this medium, since there is no gas formation by XeCl excimer laser pulses in saline. Furthermore, a more pronounced reduction in gas production can be anticipated by lowering the applied energy fluence. Recent studies indicate that a low energy fluence will result as well in a marked reduction of water vapour bubble formation [9,10]. It is conceivable that this combined effect might reduce the vascular wall damage. However, a low energy fluence will also result in a reduction of tissue ablation volume. The most optimal approach in excimer laser angioplasty remains unclear and warrants further investigation.

Limitations of the Study

The results of our study cannot be extrapolated to the clinical setting without any reserve. The experiments of the laser catheters tested were performed at different energy fluences on adjacent areas of the same tissue specimen, assuming that the tissue composition of the porcine aorta was homogeneous. It can be anticipated that with the use of human atheroma, the gas production is less predictive, related to the variation in tissue composition.

The experiments were performed using saline as a surrounding medium to evaluate the laser tissue interaction. The limited observations of the gas production in blood were performed to illustrate the effect of excimer laser exposure in this liquid medium. Further investigation is needed to evaluate the laser tissue interaction using human atherosclerotic specimen in blood.

Furthermore, the experiments were performed with the use of the laser catheter perpendicular to the aortic tissue, whereas in the clinical situation the laser catheter is positioned parallel to the long axis of the coronary vessel. This latter

situation allows runoff of gas accumulation and may diminish the severity of the mechanical damage of the vascular wall.

Recent experiments have indicated that the induction of vascular wall damage is the result of the water vapour formation. We assume that the insoluble gas formation contributes to the vascular wall damage. Our in vitro model did not allow us to separate the effects induced by water vapour bubbles from insoluble gas formation. The contribution of water vapour bubbles and gas formation in excimer laser with respect to vascular wall damage needs further investigation.

Another limitation is the assumption that the energy exposure during 125 pulses was comparable using both systems. The CVX-300 operates at a lowest threshold of 25 Hz and a fixed exposure time of 5 seconds. Consequently, the exposure time of the Dymcr 200+, which operates at a pulse frequency of 20 Hz, was adapted to 6.25 seconds. The results of our study using similar energy exposure (125 pulses) for both systems may be affected by the small differences in exposure time.

ACKNOWLEDGMENTS

The authors acknowledge the support of Wim Voorn, from the Department of Clinical Epidemiology and Biostatistics for statistical analysis.

REFERENCES

1. Linsker R, Srinivasan R, Wynne JJ, Alonso DR. Far-ultraviolet laser ablation of atherosclerotic lesions. *Lasers Surg Med* 1984; 4:201–206.
2. Grundfest WS, Litvack IF, Goldenberg T, Sherman T, Morgenstern L, Carroll R, Fishbein M, Forrester J, Margitan J, McDermid S, Pacala TJ, Rider DM, Laudenslager JB. Pulsed ultraviolet lasers and the potential for safe laser angioplasty. *Am J Surg* 1985; 150:220–226.
3. Grundfest WS, Litvack F, Forrester JS, Goldenberg T, Swan HJC, Morgenstern L, Fishbein M, McDermid IS, Rider DM, Pacala TJ, Laudenslager JB. Laser ablation of human atherosclerotic plaque without adjacent tissue injury. *J Am Coll Cardiol* 1985; 5:929–933.
4. Isner JM, Donaldson RF, Deckelbaum LI, Clarke RH, Laliberte SM, Ucci AZ, Salem DN, Konstam MA. The excimer laser: gross, light microscopic and ultra-structural analysis of potential advantages for use in laser therapy of cardiovascular disease. *J Am Coll Cardiol* 1985; 6:1102–1109.
5. Sartori M, Henry PD, Sauerbrey R, Tittel FK, Weilbaeher D, Roberts R. Tissue interactions and measurement of ablation rates with ultraviolet and visible lasers

- in canine and human arteries. *Lasers Surg Med* 1987; 7:300-306.
6. Singleton DL, Paraskevopoulos G, Taylor RS, Higginson LA. Excimer laser angioplasty: Tissue ablation, arterial response, and fiber optic delivery. *IEEE J Quant Elec*, QE-23, 1987; 1772-1782.
 7. Litvack F, Grundfest WS, Goldenberg T, Laudenslager J, Pacala T, Segalowitz J, Forrester JS. Pulsed laser angioplasty: Wavelength power and energy dependencies relevant to clinical application. *Lasers Surg Med* 1988; 8:60-65.
 8. Gijsbers GHM, Sprangers RLH, Van Gemert MJC. Excimer laser coronary angioplasty: Laser-tissue interactions at 308 nm. In: *Primer on Laser Angioplasty*, 2nd ed, chap. 13: Ginsburg R, Geschwind H., eds. Mount Kisco, NY: Futura, pp 217-224.
 9. Van Leeuwen FG, Van Erven L, Meertens JH, Motamedi M, Post MJ, Borst C. Origin of arterial wall dissections induced by pulsed excimer and mid-infrared laser ablation in the pig. *J Am Coll Cardiol* 1992; 19:1610-1618.
 10. Van Leeuwen TH, Meertens JH, Velema E, Post MJ, Borst C. Intraluminal vapour bubble induced by excimer laser pulse causes microsecond arterial dilatation an invagination leading to extensive wall damage in the rabbit. *Circulation* 1993; 87:1258-1263.
 11. Gijsbers GHM, Sprangers RLH, Keijzer M, De Bakker JMT, Van Leeuwen TG, Verdaasdonk RM, Borst C, Van Gemert MJC. Some laser-tissue interactions in 308 nm excimer laser coronary angioplasty. *J Intervent Cardiol* 1990; 3:231-241.
 12. Gijsbers GHM, Van den Broecke DG, Sprangers RLH, Van Gemert MJC. Effect of force on ablation depth for a XeCl excimer laser beam delivered by an optical fiber in contract with arterial tissue under saline. *Lasers Surg Med* 1992; 12:576-584.
 13. Bittl JA, Sanborn TA, Tcheng JE, Siegel RM, Ellis SG. Clinical success, complications and restenosis rates with excimer laser coronary angioplasty. *Am J Cardiol* 1992; 70:1533-1539.
 14. Margolis JR, Mehta S. Excimer laser coronary angioplasty. *Am J Cardiol* 1992; 69:3F-11F.
 15. Litvack F, Eigler NL, Forrester JS. In search of the optimized excimer laser angioplasty system. *Circulation* 1993; 87:1421-1422.
 16. Asada M, Kvasnicka J, Geschwind J. Effects of pulsed lasers on agar model simulation of the arterial wall. *Lasers Surg Med* 1993; 13:405-411.
 17. Nakamura F, Kvasnicka J, Uchida Y, Geschwind HJ. Percutaneous angioscopic evaluation of luminal changes induced by excimer laser angioplasty. *Am Heart J* 1992; 124:1467-1472.
 18. Diethrich EB, Hanafy HM, Santiago OJ, Bahadir I. Angioscopy after coronary excimer laser angioplasty. *J Am Coll Cardiol* 1991; 18:643-645.
 19. Davis GS, Bott-Silverman C, Goormastic M, Gerrity RG, Kittrell C, Feld M, Kramer JR. Gas volume quantitation during argon ion laser ablation of atheromatous aorta in blood and 0.9% saline. *Lasers Surg Med* 1988; 8:72-76.
 20. Gijsbers GHM, Sprangers RLH, Van den Broecke DG, Van Wieringen N, Brugmans MJP, Van Gemert MJC. Temperature increase during in vitro 308 nm excimer laser ablation of porcine aortic tissue. *SPIE Vol. 1425 Diagnostic and Therapeutic Cardiovascular Interventions* 1991; 94-101.
 21. Jansen ED, Le TH, Welch AJ. Excimer, Ho:YAG, and Q-switched Ho:YAG ablation of aorta; a comparison of temperature and tissue damage in vitro. *Applied Optics* 1993; 32:525-534.
 22. Baumbach A, Oswald H, Kvasnicka E, Fleck E, Geschwind HJ, Ozbek C, Reifart N, Bertrand ME, Karsch KR. Clinical results of coronary excimer laser angioplasty: Report from the european coronary excimer laser angioplasty registry. *Eur Heart J* 1994; 15:89-96.
 23. Litvack F, Eigler N, Margolis J, Rothbaum D, Bresnahan JF, Holmes D, Untereker W, Leon M, Kent K, Pichard A, King S, Ghazzal Z, Cummins F, Krauthamer D, Palacios I, Block P, Hartzler GO, O'Neill W, Cowley M, Roubin G, Klein LW, Frankel PS, Adams C, Goldenberg T, Laudenslager J, Grundfest WS, Forrester JS. Percutaneous excimer laser coronary angioplasty: Results in the first consecutive 3,000 patients. *J Am Coll Cardiol* 1994; 23:323-329.
 24. Andreas Baumbach, John A. Bittl, Eckart Fleck, Herbert J. Geschwind, Timothy A. Sanborn, James E. Tcheng, Karl R. Karsch, and the coinvestigators of the U.S. and European Percutaneous Excimer Laser Coronary Angioplasty (PELCA) Registries. Acute complications of excimer laser coronary angioplasty: A detailed analysis of multicenter results. *J Am Coll Cardiol* 1994; 23:1305-1313.
 25. Peter J. Fitzgerald, Paul G. Yock. Mechanisms and outcomes of angioplasty and atherectomy assessed by intravascular ultrasound imaging. *J Clin Ultrasound* 1993; 21:579-588.
 26. Alan N. Tenaglia, Christopher E. Buller, Katherine B. Kisslo, Harry R. Phillips, Richard S. Stack, Charles J. Davidson. Intracoronary ultrasound predictors of adverse outcomes after coronary artery interventions. *J Am Coll Cardiol* 1992; 20:1385-1390.
 27. Stephen R. Ramee, Christopher J. White, Tyrone J. Collins, Juan E. Mesa, Joseph P. Murgo. Percutaneous angiography during coronary angioplasty using a steerable microangioscope. *J Am Coll* 1991; 17:100-105.
 28. Peter de Heijer, David P. Foley, Javier Escaned, Hans L. Hillege, Rene H. van Dijk, Patrick W. Serruys, Kong I. Lie. Angioscopic versus angiographic detection of intimal dissection and intracoronary thrombus. *J Am Coll Cardiol* 1994; 649-654.