

## COMBUSTION OF COAL AND ALTERNATIVE FUELS IN OXY-FUEL ATMOSPHERE

Wojciech Moroń, Krzysztof Czajka, Anna Kisiela

Wroclaw University of Technology, Faculty of Mechanical and Power Engineering, Institute of Power Engineering and Fluid Mechanics

**Abstract.** In this paper, results of fuel behavior during combustion of coal and alternative fuels in oxy-fuel atmosphere are presented. The objective of this work was to evaluate the dependencies between properties (ignition, explosion parameters, emissions of  $\text{NO}_x$  and  $\text{SO}_2$ ) of coal and alternative fuels. The exchange of air for recycled flue gas and oxygen mixture, leads to changes of combustion behavior i.e. lower emission of  $\text{NO}_x$ ,  $\text{SO}_2$  and increased ignition delay time. Nevertheless, performed experiments do not indicate significant differences in explosion parameters among different fuels at air and 30% $\text{O}_2$ /70% $\text{CO}_2$  atmosphere.

**Keywords:** ignition, emission, oxy atmosphere

### SPALANIE WĘGLI I PALIWI ALTERNATYWNYCH W ATMOSFERZE TLENOWEJ

**Streszczenie.** Artykuł przedstawia wyniki badań uzyskane w czasie realizacji procesu spalania w atmosferze oxy-fuel. Prezentowane wyniki skupiają się na określeniu takich własności jak zapłon, parametry wybuchowości, emisję zanieczyszczeń gazowych  $\text{NO}_x$ ,  $\text{SO}_2$  węgla i paliw alternatywnych. Eksperyment został wykonany na 3 metrowym pionowym reaktorze przepływowym, 20 litrowej sferycznej kuli i w 1 metrowym pionowym piecu do badania zapłonu. Zastosowanie technologii spalania w tlenie może znacząco polepszyć możliwości użytkowania paliw stałych. Eliminacja, z atmosfery spalania, azotu prowadzi do obniżenia emisji zanieczyszczeń gazowych  $\text{NO}_x$ ,  $\text{SO}_2$  oraz wzrostu czasu opóźnienia zapłonu. Niemniej, przeprowadzone eksperymenty nie wykazały wpływu atmosfery 30% $\text{O}_2$ /70% $\text{CO}_2$  na parametry wybuchowości.

**Słowa kluczowe:** zapłon, emisja, atmosfera oxy

### Introduction

Oxy fuel combustion is one of the leading carbon capture and storage (CCS) technology. In this process, the fuel is combusted in a mixture of recycled flue gases and nearly pure oxygen, instead of air. The main attraction of this technology is production of a flue gas containing mainly  $\text{CO}_2$  and water vapour. Since the  $\text{H}_2\text{O}$  can be easily removed by condensation, the almost pure  $\text{CO}_2$  stream becomes suitable for compression, transport and storage.

During the last decade, the oxy fuel technologies have been significantly developed to the point where several demonstration projects have begun [11]. A number of state-of-the-art reviews have been presented [1, 7, 10]. Nevertheless, while oxy fuel conditions differ considerably from air conditions, several issues, i.e. ignition mechanism, explosion risks,  $\text{SO}_2$  and  $\text{NO}_x$  emissions still need clarification.

The ignition of solid fuel particles is an important step of combustion mechanism due to its influence on flame stability and pollutant formation. The ignition temperature and ignition delay time are not an inherent property of the fuel, but they depends also on the operating conditions (i.e. atmosphere composition, heating rate, etc.). In oxy fuel atmosphere, poor ignition quality has been often noted during pilot scale experiments [9]. As shown in the paper [8] the ignition delay time is longer and the ignition temperature is higher in an  $\text{O}_2/\text{CO}_2$  environment than in an  $\text{O}_2/\text{N}_2$ . Authors suggested that the longer ignition delay in  $\text{O}_2/\text{CO}_2$  mixtures is mainly due to the higher heat capacity of  $\text{CO}_2$ . The same effect has been attributed also to endothermic char- $\text{CO}_2$  gasification reaction [6].

The explosion parameters of pulverized solid fuels under oxy fuel conditions are important for burner design and development, and power plant safety considerations. The amount of experimental data in the literature is very limited and ambiguous. As presented in [4] substitution of air by oxy fuel atmosphere with higher  $\text{O}_2$  concentration increases the rate of pressure rise. On the other hand, results presented in [3] do not indicate differences between explosion parameters in air and oxy fuels atmospheres.

The reduction of emissions is an important environmental issue due to the  $\text{NO}_x$  and  $\text{SO}_2$  contribution to acid rain formation. Many of researchers [5, 7, 10] indicated that oxy fuel combustion conditions may decrease the  $\text{NO}_x$  emission intensity due to: (1) lower partial pressure of  $\text{N}_2$ , (2) different radical and gas

compositions within and around the char particles and (3) reburning of recycled flue gas containing  $\text{NO}$ . As shown in [2] the  $\text{SO}_2$  emission intensity does not change significantly under oxy fuel and air conditions. However, recycling of flue gasses may increase the  $\text{SO}_2$  concentration in the furnace and raise potential corrosion issues.

The aim of this paper is to examine the behaviour of various coals and alternative fuels during the oxy fuel combustion and to compare obtained results with data possessed in referenced air atmosphere. The principal objective of the study is to determine the impact of oxy fuel conditions on the ignition mechanism, explosion risks and  $\text{SO}_2$  and  $\text{NO}_x$  emissions.

### 1. Fuel samples

Eight fuels were selected for the research, i.e. hard coals Janina and Sobieski, lignites Turów and Belchatów, alternative fuels: wood pellet (PelD), sunflower pellet (PelS), sewage sludge (OsadS) and solid recovery fuel (SRF). The chosen alternative fuels represent three groups, defined according to source and origins: wood/woody biomass (PelD), herbaceous/agricultural biomass (PelS) and solid waste (OsadS and SRF). Physicochemical properties of investigated fuels differ substantially and are summarized in Tab. 1.

Table 1. Proximate and ultimate analyses of fuel (on air dried basis)

Fuel	Proximate analyses				
	W	A	V	FC	FR
	%				
Janina	3.1	8.6	32.7	55.6	1.70
Turów	2.0	17.5	46.6	33.8	0.73
Sobieski	3.7	10.4	33.0	52.9	1.60
Belchatów	4.4	16.1	44.4	35.0	0.80
PelS	2.1	2.7	73.5	21.7	0.30
PelD	4.5	1.3	78.3	15.9	0.20
OsadS	3.3	42.3	46.5	7.8	0.17
SRF	3.5	17.0	68.3	11.2	0.16
Fuel	Ultimate analyses				
	C	H	N	S	O
	%				
Janina	75.7	4.3	1.2	1.2	5.9
Turów	59.0	4.8	0.5	1.3	14.8
Sobieski	76.0	4.1	1.2	1.6	2.9
Belchatów	55.2	4.5	0.6	1.8	17.4
PelS	51.9	5.7	0.7	0.1	36.8
PelD	52.1	6.5	0.4	0.1	35.2
OsadS	29.8	4.0	3.8	2.3	14.5
SRF	51.3	6.6	0.7	0.2	20.6

Comparing to coals, alternative fuels contain high amount of volatiles and lower fuel ratio FR. Moreover, sewage sludge and SRF contain high amount of ash, caused by the process of their production. The ratio between fractions of the proximate analysis is shown on the Fig. 1. All of the investigated alternative fuels are characterized by the fuel ratio lower than 0.5, thus the predominant form of combustion is gas – phase oxidation of the volatile matter. Fuel ratio lower than unity, may increase the fire and explosion risks during combustion and co-combustion of these fuels. Particularly exposed to the hazard of fire and explosion are the feeding and the preparation systems. Nevertheless, high amount of volatiles (low fuel ratio) may promote ignition and increase flame stability.

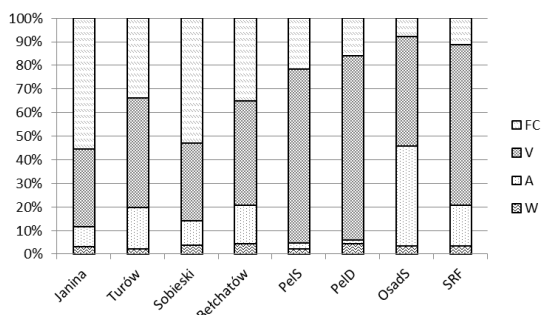

Fig. 1. Proximate analyses diagram

## 2. Results

### 2.1. Ignition of coal particle suspension in oxy-fuel atmosphere

Ignition measurements in oxy-fuel ( $O_2/CO_2$ ) atmosphere were performed using monodisperse coal dust clouds experimental technique. An electrically heated vertical furnace (Fig. 2) coupled with optical particle detection has been applied to study the ignition of clouds of pulverized coal. The experimental program involved the variation of furnace temperatures,  $T_g$  (ranging from 400°C to 900°C), type of atmosphere (air, oxy 30% $O_2/70\%CO_2$ ) and fuel type.

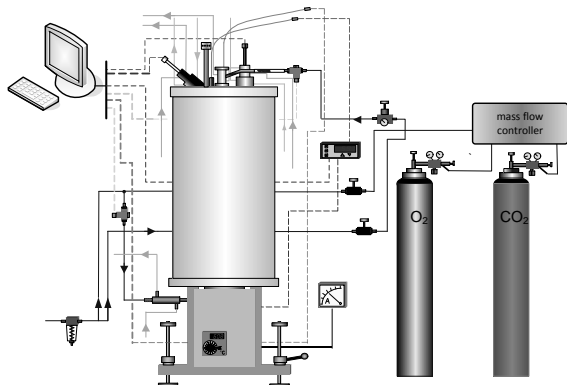

Fig. 2. Vertical furnace diagram

A series of experiments were undertaken to determine the sensitivity of the cloud ignition delay time to adjustable experimental variables – the furnace temperature and oxy-fuel ( $O_2/CO_2$ ) atmosphere. The variation of the ignition delay time with respect of the furnace temperatures for fuels is reported in Fig. 3.

As shown in the Figure 3, ignition temperature and ignition delay time vary depending on the fuel type. Regardless of the atmosphere composition, the lowest ignition parameters were measured for biomass PeIS, PeID and for lignites Turów, Belchatów. On the other hand, long ignition delay time and high ignition temperature were obtained for hard coal Janina, Sobieski and sewage sludge OsadS.

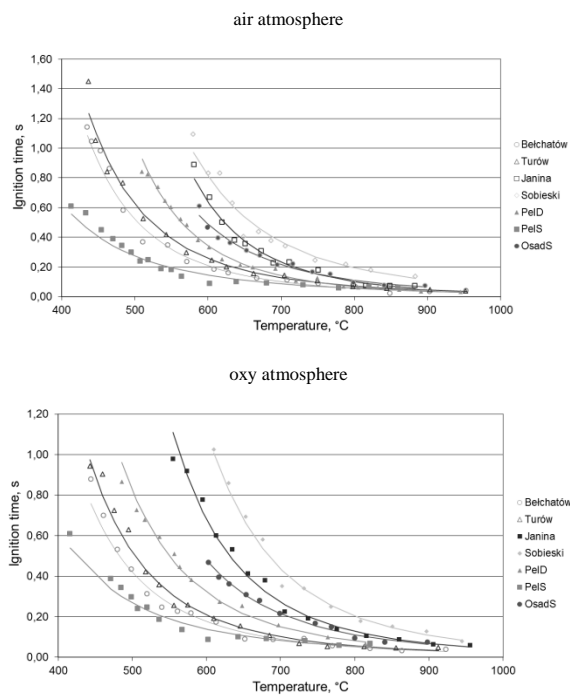

Fig. 3. Ignition characteristics for fuels in different atmosphere

In order to investigate the impact of atmosphere composition on ignition parameters, results obtained for air and 30% $O_2/70\%CO_2$  are summarized in Tab. 2.

Table 2. Ignition parameters of fuels

Fuel	Air		30% $O_2/70\%CO_2$	
	MTI <sub>cs</sub> , °C	t <sub>2650</sub> , s	MTI <sub>cs</sub> , °C	t <sub>2650</sub> , s
Janina	555	0,37	581	0,42
Turów	437	0,178	443	0,142
Sobieski	580	0,536	610	0,682
Belchatów	435	0,142	444	0,123
PeID	498	0,2147	507	0,2345
PeIS	403	0,1100	412	0,1841
OsadS	588	0,3176	593	0,3518

Obtained results revealed that exchanging air for 30% $O_2/70\%CO_2$  atmosphere, in general, leads to slight decrease of ignition temperature (MTI<sub>C</sub>) and to increase of ignition delay time (t<sub>2650</sub>). The highest difference between ignition temperature in air and oxy fuel conditions, measured for hard coal Sobieski, was 30°C, the mean difference calculated for all investigated fuels was about 15°C. For 5 of 7 analysed fuels, presence of  $O_2/CO_2$  mixture increase ignition delay time by average about 0,06s. For lignite Turów and Belchatów oxy fuel conditions decrease the ignition delay time by 0,04s and 0,02s respectively.

### 2.2. Dust explosion characteristic in oxy-fuel atmosphere

Ignition of fuels dust cloud leads to the explosion. To cause the explosion, three conditions must be fulfilled, i.e. proper dust concentration, access to oxygen and a source of explosion (embers, fire). Knowledge about characteristics of the explosion is important due to prevention (lower explosive limit, LEL) and providing information on the consequences (maximum explosion pressure p<sub>max</sub>, maximum rate of pressure rise (dp/dt)<sub>max</sub>, the K<sub>st</sub> parameter). The explosion behavior was determined using 20 litre – sphere presented in Fig. 4.

Results obtained for investigated fuels are presented in Fig. 5 and Tab. 3.

It may be concluded that biomass and sewage sludges are characterized by lower explosion parameters than coals and lignites but their explosion tendency is similar. This can be explained by the high content of volatiles and low onset temperature of devolatilization (from range 200-400°C).

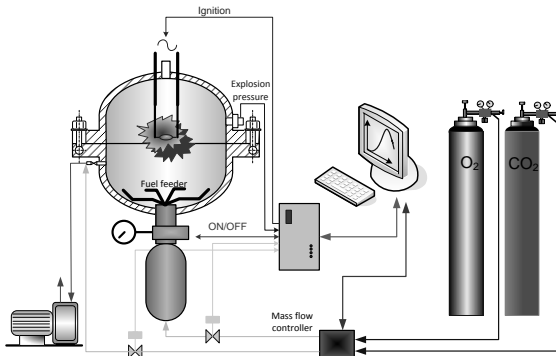

Fig. 4. 20 litre – sphere diagram

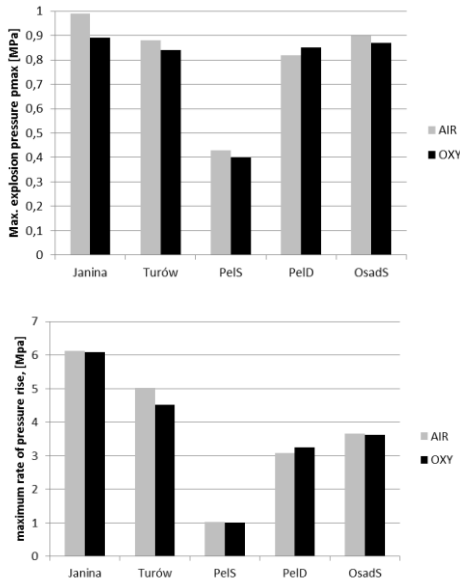

Fig. 5. Comparison of explosion parameters for investigated fuels

Regardless of the fuel type, no significant impact of the atmosphere composition on the explosion parameters was found. The maximum explosion pressure for all investigated fuels varies from 0,43 MPa to 0,99 MPa, and from 0,45 MPa to 0,96 MPa in air and oxy fuel atmosphere respectively. The maximum rate of pressure rise was equal from 3,61 MPa/s to 21,74 MPa/s in air and from 3,56 MPa/s to 21,43 MPa/s in 30%O<sub>2</sub>/70%CO<sub>2</sub>. The K<sub>st</sub> parameter, describing the maximum rate of pressure rise in 1m<sup>3</sup> vessel when a dust is ignited, differs from 1,06 MPa m/s to 6,18 MPa m/s in air and from 1,01 MPa m/s to 6,09 MPa m/s in oxy fuel atmosphere.

Table 3. Explosion parameters of investigated fuels

Fuel	maximum explosion pressure		maximum rate of pressure rise, (dP/dt) <sub>max</sub>		the K <sub>st</sub> parameter	
	MPa		MPa/s		MPa m/s	
	Air	OXY	Air	OXY	Air	OXY
Janina	0,99	0,89	21,54	21,43	6,13	6,09
Turów	0,88	0,84	17,64	15,87	5,02	4,51
Sobieski	0,92	0,85	17,92	18,26	5,10	5,19
Belchatów	0,94	0,82	21,74	10,38	6,18	2,95
PelD	0,82	0,80	9,62	9,82	2,74	2,79
PelS	0,43	0,45	3,61	3,56	1,06	1,01
OsadS	0,90	0,96	13,68	13,12	3,89	3,73

### 2.3. NO<sub>x</sub> and SO<sub>2</sub> emission in oxy-fuel atmosphere

Predicting of the NO<sub>x</sub> and SO<sub>2</sub> emission during the combustion of fuels is more difficult than for coal. Some fuels such as SRF may have lower nitrogen content, what can result lower NO<sub>x</sub> emission. Sewage sludges have higher nitrogen content than typical coal, but the emission of NO<sub>x</sub> does not depend only

on the nitrogen content in the fuel, but also on the path of emission and combustion temperature. If the greater part of the nitrogen is emitted with the volatile matter, it will results in lower emission of NO<sub>x</sub>, especially for combustion in Low-NO<sub>x</sub> burners. Furthermore, NO<sub>x</sub> is created by the thermal reaction between nitrogen and oxygen. Hence, higher moisture content in sewage sludges may decrease the maximum flame temperature and thereby reduce thermal NO<sub>x</sub> formation. Evaluation of the emission of sulfur and nitrogen oxides was performed in the 3 meter long Plug Flow Reactor, where fuel and blend were combusted. Fig. 6 shows the entire rig.

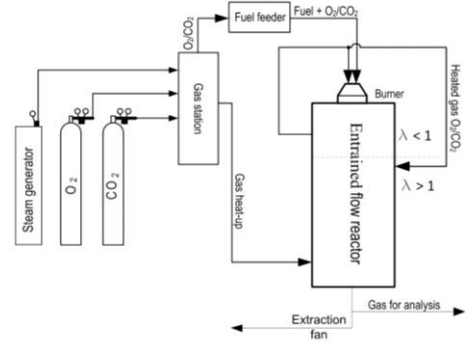

Fig. 6. Gas installation diagram

In the second stage of experiment, fuels were combusted in oxy fuel atmosphere containing 30%O<sub>2</sub> and 70%CO<sub>2</sub>. Emissions of NO<sub>x</sub> and SO<sub>2</sub> in oxy and air fuel atmosphere for Janina are shown in Fig. 7. For chosen experiment conditions it was showed that emission of NO<sub>x</sub> and SO<sub>2</sub> is higher in oxy fuel atmosphere than in air (in mg/m<sup>3</sup>). However, the volume of flue gases from oxy fuel combustion is reduced due to higher content of O<sub>2</sub> and higher density of CO<sub>2</sub> than N<sub>2</sub>.

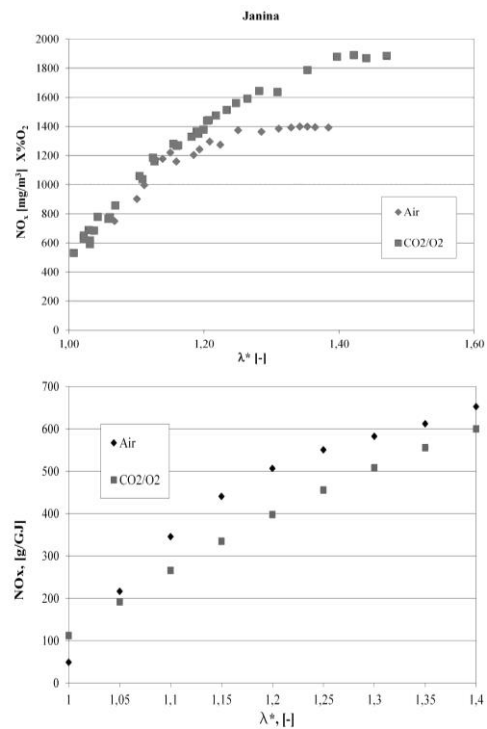

Fig. 7. NO<sub>x</sub> emission versus fuel equivalence ratio in oxy and air fuel atmosphere

Taking into account lower volume of flue gases, the overall emission of NO<sub>x</sub> during oxy fuel combustion is lower than air condition combustion (Fig. 8) (in g/GJ). The NO<sub>x</sub> reduction is thought to be the result of non-NO<sub>x</sub> formation via fixation of atmospheric nitrogen. Similar to NO<sub>x</sub> case, the SO<sub>2</sub> emission per energy input of coal in oxy fuel atmosphere is lower than in air.

The emission reduction is proportional to the share of alternative fuel. Figure 9 shows the degree of conversion of fuel sulfur to  $\text{SO}_2$  in the flue gas. It presents that the lower emission was noted in the case of oxygen-enriched atmosphere and the emission of sulfur compounds is directly proportional to the amount of elemental sulfur.

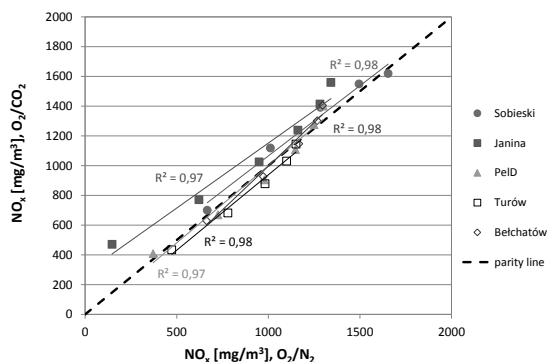

Fig. 8. The rate of conversion  $\text{NO}_x$  emissions in oxy and air fuel atmosphere

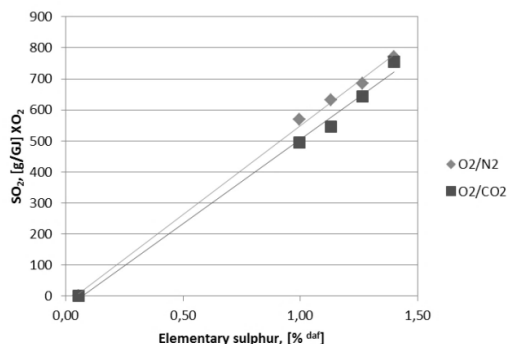

Fig. 9. The rate of conversion  $\text{NO}_x$  emissions in oxy and air fuel atmosphere

### 3. Conclusion

Analysis shows that the use of coals and alternative fuels in oxy-fuel combustion technology is possible and does not pose a risk than the use of these fuels in conventional systems. The obtained results have confirmed the following facts:

- 1) ignition parameters depends on the fuel type, the lowest ignition parameters were measured for biomass and lignites, the highest ignition parameters were obtained for hard coals and sewage sludge;
- 2) exchanging air for 30% $\text{O}_2$ /70% $\text{CO}_2$  atmosphere, in general, leads to slight decrease of ignition temperature ( $\text{MTI}_C$ ) and to increase of ignition delay time ( $t_{2650}$ ). The differences in ignition temperature and ignition delay time are a consequence of the higher density and heat capacity of  $\text{CO}_2$  than  $\text{N}_2$ . The impact of  $\text{CO}_2$  presence is visible even though the reactivity of the fuel-oxidizer mixture in oxy fuel conditions is higher (due to higher concentration of oxygen);
- 3) biomass and sewage sludges are characterized by lower explosion parameters than coals and lignites but their explosion tendency is higher. This can be explained by the high content of volatiles and low onset temperature of devolatilization;
- 4) regardless of the fuel type, no significant impact of the atmosphere composition on the explosion parameters (the maximum explosion pressure, the maximum rate of pressure rise, the  $K_{st}$  parameter) were found;
- 5) the overall emission of  $\text{NO}_x$  related to energy input (in g/GJ), during oxy fuel combustion is lower than air condition combustion. The  $\text{NO}_x$  reduction is thought to be the result of non- $\text{NO}_x$  formation via fixation of atmospheric nitrogen;
- 6) the emission of  $\text{SO}_2$  related to energy input (in g/GJ), during oxy fuel combustion is lower than air condition combustion and it is proportional to the amount of elemental sulfur. The  $\text{SO}_2$  reduction is a result of fixation of sulfur in the ash.

### Acknowledgements

Scientific work was supported by the National Centre for Research and Development, as Strategic Project PS/E/2/66420/10 "Advanced Technologies for Energy Generation: Oxy-combustion technology for PC and FBC boilers with  $\text{CO}_2$  capture". The support is gratefully acknowledged.

### References

- [1] Edge P., Gharebaghi M., Irons R., Porter R., Porter R.T.J., Pourkashanian M., Smith D., Stephenson P., Williams A.: Combustion modelling opportunities and challenges for oxy-coal carbon capture technology. *Chemical Engineering Research and Design* 89, 2011, 1470-1493.
- [2] Hu Y., Naito S., Kobayashi N., Hasatani M.:  $\text{CO}_2$ ,  $\text{NO}_x$  and  $\text{SO}_2$  emissions from the combustion of coal with high oxygen concentration gases. *Fuel*, 2000, 79, 1925-1932.
- [3] Man C.K., Gibbins J.R.: Factors affecting coal particle ignition under oxyfuel combustion atmospheres. *Fuel*, 90, 2011, 294-304.
- [4] Norman F., Berghmans J., Verplaetsen F.: The dust explosion characteristics of coal dust in an oxygen enriched atmosphere. *Procedia Engineering*, 45, 2012, 399-402.
- [5] Normann F., Andersson K., Leckner B., Johnsson F.: Emission control of nitrogen oxides in the oxy-fuel process. *Progress in Energy and Combustion Science*, 2009, 35, 385-397.
- [6] Qiao Y., Zhang L., Binner E., Xu M., Li C-Z.: An investigation of the causes of the difference in coal particle ignition temperature between combustion in air and in  $\text{O}_2/\text{CO}_2$ . *Fuel* 2010, 89, 3381-3387.
- [7] Scheffknecht G., Al-Makhadmeh L., Schnell U., Maier J.: Oxy-fuel coal combustion – A review of the current state-of-art. *International Journal of Greenhouse Gas Control* 5S, 2011, 16-35.
- [8] Shaddix C.R., Molina A.: Particle imaging of ignition and devolatilization of pulverized coal during oxy-fuel combustion. *Proceedings of the Combustion Institute* 2009, 32, 2091-2098.
- [9] Strömberg L., Lindgren G., Jacoby J., Giering R., Anheden M., Burchhardt U.: Update on Vattenfall's 30 MWth oxyfuel pilot plant in Schwarze Pumpe. *Energy Procedia*, 2009, 1, 581-589.
- [10] Toftegaard M., Brix J., Jensen P., Glarborg P., Jensen A.: Oxy – fuel combustion of solid fuels. *Progress in Energy and Combustion Science*, 2010, 36, 581-625.
- [11] Wall T., Liu Y., Spero C., Elliott L., Khare S., Rathnam R., Zeenathal F., Moghtaderi B., Buhre B., Sheng C., Gupta R., Yamada T., Makino K., Yu J.: An overview on oxyfuel coal combustion—state of the art research and technology development. *Chem. Eng. Res. Des.*, 2009, 87, 8, 1003-1016.

#### Ph.D. Eng. Wojciech Moron

e-mail: wojciech.moron@pwr.edu.pl

Research and teaching employee University of Technology. Area of interest and research subjects is associated with determination of physical and chemical properties of conventional fuels and alternative fuels. He also deals with the choice of fuels, technologies, modernization and design and operation in order to improve the efficiency of use, reduce harmful emissions and reduce the cost of energy production



#### Ph.D. Eng. Krzysztof Czajka

e-mail: krzysztof.czajka@pwr.edu.pl

Research and teaching employee in the Department of Energy Engineering and Technology at Technical University of Wrocław. Research areas: thermal analysis, spectroscopic analysis, modern energy technologies, oxy-fuel combustion



#### M.Sc. Eng. Anna Kisiela

e-mail: anna.kisiela@pwr.edu.pl

PhD student of the Faculty of Mechanical and Power Engineering at Technical University of Wrocław. The subject of the research focuses on issues related to the physical chemistry of solid, thermal conversion carbon rich waste fuel and energy industry and a new generation of energy technologies.

