

DOI: 10.5604/20830157.1130165

CALCULATION OF EXTERNAL EXPOSURE DURING DISMANTLING AND SEGMENTATION OF STEAM GENERATOR

Martin Hornacek, Vladimír Necas

Slovak University of Technology in Bratislava, Faculty of Electrical Engineering and Information Technology, Institute of Nuclear and Physical Engineering

Abstract. The prediction of radiation doses obtained during dismantling of steam generator represents one of the most crucial issues within the process of decommissioning of nuclear installations. Given the fact that in Slovakia the nuclear power plant V1 in Jaslovské Bohunice is currently being decommissioned, represents the analysis of the segmentation of steam generator an actual issue. In this paper, the proposed dismantling methodology together with the results of calculations is given. Also the complex analysis of the influence of different distance of workers carrying out the dismantling as well as the influence of the time on the total collective effective dose is carried out. The results of this analysis show that the obtained doses are below the legislative limits and thus the main consequences can be applied in the process of V1 nuclear power plant decommissioning.

Keywords: decommissioning of nuclear installations, steam generator, external exposure

OBLICZENIA EKSPOZYCJI ZEWNĘTRZNEJ PODCZAS DEMONTAŻU I SEGMENTACJI GENERATORA PARY

Streszczenie. Przewidywanie dawek promieniowania na które narażona jest obsługa w trakcie demontażu generatora pary reprezentuje jedną z najbardziej kluczowych problemów w ramach procesu likwidacji obiektów jądrowych. Mając na względzie fakt, że na Słowacji elektrownia jądrowa V1 w Jaslovské Bohunice jest obecnie wycofywana z ruchu, analiza segmentacji generatora pary stanowi aktualny problem. W pracy zaproponowano metodologię demontażu i podano rezultaty obliczeń. Także złożona analiza wpływu różnych odległości pracowników przeprowadzających demontaż jak również wpływ czasu na całkowitą efektywną zespolową dawkę promieniowania jest przeprowadzony. Wyniki tej analizy pokazują że przyjęte dawki są poniżej limitów wyznaczonych normami i zatem główne konsekwencje mogą być stosowane w procesie demontażu jądrowej elektrowni V1.

Słowa kluczowe: likwidacja obiektów jądrowych, generator pary, ekspozycja zewnętrzna

Introduction

During decommissioning of nuclear power plants (NPP) many actions have to be carried out in order to achieve the desired end state. One of the tasks involved in this process is the dismantling of so called large components. The definition of term “large component” can vary greatly in different countries, but in general it can be defined as any part of nuclear facility that may be removed without being cut, that is conditioned in a non-standard package for disposal or storage and that requires specific consideration by local regulators due to its weight, its volume or the extent of its radiological contamination [20]. The extent of this definition is quite large but in case of NPPs as large components can be considered: steam generators (SG), pressurizers, reactor pressure vessels (RPV) and heads or reactor internals (core basket, protected tube unit, reactor cavity and reactor cavity bottom). All of these components are a part of the primary circuit of NPP which results in the high level of activity. This is caused either due to the neutron activation (RPV and reactor internals) or contamination by activation and fission products (pressurizer and SG).

There are 2 ways how to dismantle such components: to be cut to smaller pieces or to be handled as compact structures. Practical applications of these approaches can be summarized as follows [3, 15]:

- **Cut and dispose** – in situ treatment, examples of realized projects: NPP Gundremmingen, Germany (SGs were filled with water, frozen and cut in situ with a band saw) [25], NPP Stade, Germany (cutting of the RPV in spent fuel basin using thermal and mechanical dismantling techniques) [16, 17].
- **Pack and go** – transport to an external treatment facility, examples of realized projects: transport of 4 SGs of NPP Stade to Studsvik Radwaste in Sweden, where decontamination, segmentation (using thermal and mechanical cutting tools) and melting were carried out [4, 8, 30], transport of the RPV from the NPP Rheinsberg to the Interim Storage North in the Greifswald site [31].
- **Pack and wait** – transport to an interim storage on site, example of realized project: the transport of the RPV, reactor internals and SGs from the NPP Greifswald, Germany to the Interim Storage North [5, 6, 21]. The aim of this strategy is to store these components until their activity decreases to levels

allowing clearance of the whole component or its part without decontamination or melting.

- **Pack and dispose** – one-piece removal, transport and direct disposal in a repository, example of realized project: the transport of the RPV (together with reactor internals) of NPP Maine Yankee, USA and its disposal (after filling with concrete) in a repository at Barnwell site [9, 32].
- The selection between these strategies is strongly dependent on site-specific conditions and the complex of factors which can be divided into the following groups [20]:
- **Decommissioning issues** (e.g. the availability of mature and previously tested technologies, the original plant design, the physical and radiological conditions of the plant at the time of the project).
 - **Transportation issues** (e.g. activity and dose rate limits during transport, technical and operational issues – packaging and handling).
 - **Waste-treatment/storage issues** (e.g. decontamination, segmentation, treatment, conditioning/packaging and storage).
 - **Disposal issues** (e.g. waste-acceptance criteria or waste-package specifications, operational and long-term safety (intrusion scenarios), costs for feasibility studies, for the licensing process and for additional investments).

From the facts listed above it is obvious that the dismantling strategy of large components of NPPs with the same reactor type can differ between countries. This is also the case of Slovakia (when compared with Germany) which is characterized in the following chapter.

1. Current Situation in Slovakia

There are 2 units of the V1 NPP in Jaslovské Bohunice, Slovakia which are currently in the first stage of the decommissioning process. In this NPP, the VVER-440/230 reactor type (Russian type of pressurized water reactor) was used. Each unit had gross electrical output of 440 MW and the cessation of operation (due to the political decision as a consequence of membership negotiations with the European Union in the late 90s) was after 28 years of standard operation (1978-2006 and 1980-2008).

According to [18, 19], the start of the 2nd decommissioning stage (where the dismantling of activated and contaminated components is involved) is planned to date of 1 January 2015.

During this stage the components will be cut in situ [19]; the segmented parts (non-releasable into the environment) will be packed and disposed in the National Radioactive Waste Repository in Mochovec (where near-surface repository is currently in operation and the start of build of very low level waste repository is planned for 2016 [18]).

The same reactor type was used in units 1-4 of German NPP in Greifswald, however, in this case the pack and wait approach was applied. The difference between these two decommissioning projects can be explained (among other factors) by the fact that in Germany only sub-surface repositories are in operation [7] and thus the costs for disposal are high. On the other hand, as was mentioned, in case of Slovakia only near-surface repository is currently in operation and the build of very low level waste (VLLW) repository is planned. Therefore the costs for disposal are lower than in case of Germany. The decay storage of the components results in decrease of activity but, on the other hand, increases future disposal costs (for instance due to economic factors like inflation).

The schedule of the V1 NPP decommissioning project only confirms the fact that the calculation of exposure of workers during dismantling and its optimization according to the ALARA principle is a crucial and actual issue.

2. Technical Description of Steam Generator used in NPPs with VVER-440 type reactor

The subject of the analysis in this paper is the steam generator used in each of the 6 loops of the primary circuit within one unit. The SG is depicted in Fig. 1 and Fig. 2:

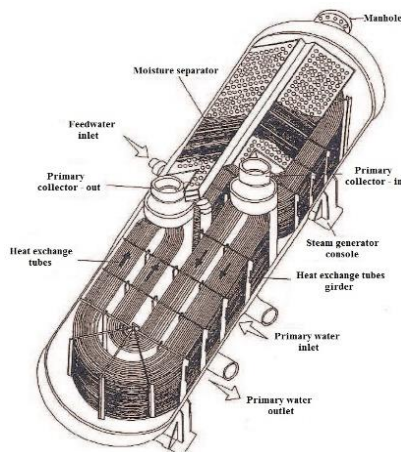

Fig. 1. Steam generator for NPPs with VVER-440 type reactor [23]

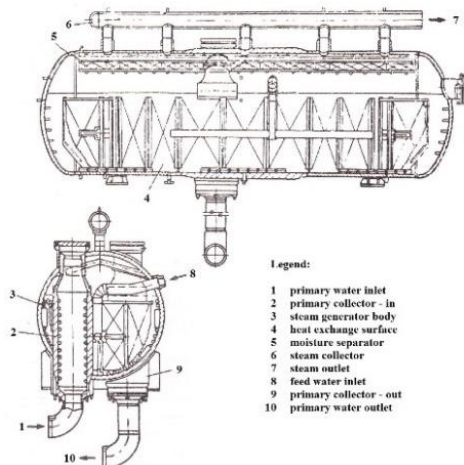

Fig. 2. Steam generator for NPPs with VVER-440 type reactor – cross section [2]

From the construction point of view the vessel is made of carbon steel 22K; the collector material as well as the heat exchanging tube material is titanium stabilized austenitic steel with 0.08% carbon, 18% chromium, 10% nickel and less than 1% titanium [13].

3. Used Calculation Tools

For the calculation of external exposure, the computer code VISIPLAN 3D ALARA was applied. In the following subchapter this code is briefly characterized from the perspective of calculation principle and methodology.

3.1. Computer Code VISIPLAN 3D ALARA – Calculation Principle

The photon fluency rate at the dose point near the volume source can be determined by considering the volume source as consisting of a number of point sources. By adding the contribution of every point source to the dose at the dose point the photon fluency rate at the dose point is expressed as [29]:

$$\varphi = \int_V \frac{S B e^{-b}}{4\pi\rho^2} dV \quad [\text{m}^{-2}\text{s}^{-1}], \quad (1)$$

where: S – source strength per unit volume [n s^{-1}]; ρ – distance from a point source [m]; B – buildup coefficient [-]; V – volume [m^3].

Each small source is called a kernel and the process of integration, where the contribution to the dose of each point is added up, is called "point kernel" integration. This is the method used in the VISIPLAN software – Fig. 3:

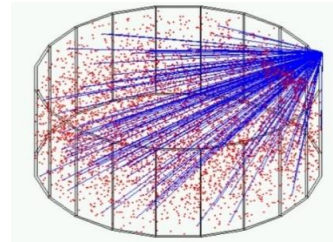

Fig. 3. Point kernel integration [29]

Based on the photon fluency rate at a point it is possible to calculate the effective dose rate depending on the dose conversion factors selected in the calculations [29]:

$$E = \sum_i h_i \cdot \phi_i \quad [\text{Sv/s}], \quad (2)$$

where:

h_i – dose conversion coefficient for photons of energy [Sv per photon/m^2];

ϕ_i – fluency rate of the photons at energy [$\text{m}^{-2}\text{s}^{-1}$].

3.2. Computer Code VISIPLAN 3D ALARA – Methodology

ALARA dose assessment for work planning is difficult in complex nuclear installations. The aspects of geometry, source distribution, shield geometry together with work organization, type and work duration are important in the dose prognoses.

The VISIPLAN 3D ALARA planning tool calculates the dose situation for different work scenarios defined by the ALARA analyst, taking into account the worker position, work duration, geometry and source distribution changes [29]. The VISIPLAN methodology consists of four stages [29]:

- Model building stage – characterization of the site or work area (geometry and material composition), radioactive source characterization (position, strength, geometry and composition).

- General analysis stage – calculation of dose maps of the working areas – identification of the high dose rate areas.
- Detail planning stage – trajectory calculations (characterization of workers and time for each performed activity), evaluation of accumulated effective dose.
- Follow-up stage – comparison of the predicted and received doses, modification and application of model.

In general it can be said that the computer code VISIPLAN 3D ALARA is a suitable calculation tool for prediction of radiation doses within various tasks of the process of decommissioning of NPPs as well as in the area of radioactive waste management which was realized in many projects, e.g. [11, 12, 27].

4. General Assumptions for Calculations and Input Data

For the calculation of external exposure, several input parameters have to be known: geometric dimensions, material composition, mass (total and of individual parts), radioactive sources strength and composition and the type and duration of performing activities. In the following subchapters all these parameters will be described.

4.1. Calculation Model of Steam Generator

The created model of SG (Fig. 4) is based on the available technical documentation and can be divided into the following parts:

- Heat exchange tubes – length approx. 9.7 m, total mass 34.7 t.
- Collectors – modeled as tube, height 4.2 m, wall thickness of 13.86 cm, outer radius 48.5 cm, mass 12.7 t each.
- SG casing – one cylindrical part (length 9.5 m, wall thickness of 8.5 cm, outer radius 169 cm, mass 84.2 t) and two hemispheres (same outer radius and wall thickness as cylindrical part, mass 14.6 t each hemisphere).

The total mass of the SG is approx. 173 t.

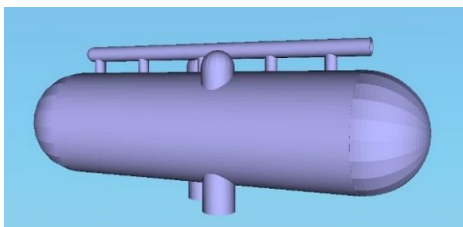

Fig. 4. Model of steam generator – computer code VISIPLAN 3D ALARA

4.2. Radiological Parameters

The initial activity values (considered to start of 2nd decommissioning stage of V1 NPP – 1 January 2015) are estimated values for the calculation of parameters of the decommissioning process and are depicted in Table 1.

Table 1. Activity content of steam generator – initial values

Part of steam generator	Activity content [Bq]	Mass activity [Bq/kg]
Heat exchange tubes	7.29E+09	2.10E+05
Collector	7.08E+06	5.59E+02
Steam generator casing	1.88E+05	1.66E+00
Total	7.30E+09	-

It is necessary to emphasize that the activity values of heat exchange tubes and collectors are after applied pre-dismantling decontamination with decontamination factor (DF) of 100.

The value of DF is based on finished decontamination projects in Germany – the full system decontamination at German NPP Unterweser (1410 MW gross, more than 30 years of operation),

achieved DF of 147 of SG tube section [28] and German NPP Stade (672 MW gross, operation 1972-2003), achieved DF of 160 of SG tube section [26].

The mass activity of SG casing is on the level of approx. 2 Bq/kg (independently on the application of pre-dismantling decontamination because it is actually the part of secondary circuit), which is markedly below the limits for unconditional release stated in [24]. Therefore in the following calculations this part can be neglected and during cutting of SG parts this part can be considered as shielding.

The radioactive inventory comprises activation and fission products which have contaminated the inner surfaces of heat exchange tubes and collectors during the operation of NPP. Given the fact that the SG is in relatively great distance from the active zone, contamination is the only source of radioactivity.

The activation products consist of elements, whose oxide layers (caused by corrosion) were transported with the heat transfer medium, activated by neutrons and deposited on the inner surfaces of technological equipment.

The inventory of activation products considered in calculations is derived from the radiological characterization of V1 NPP in Slovakia and predominantly consists of ^{55}Fe , ^{60}Co and ^{63}Ni . The amount of fission products (^{129}I , ^{137}Cs) is very limited.

4.3. Worker Group

The dismantling of SG is considered to be performed in situ, i.e., within the building structure of Unit 1 and Unit 2 respectively.

The considered worker group which is carrying out dismantling and fragmentation consists of 5 workers which are divided into following groups:

- Cutter and junior technician – realization of cutting activities – the distance from the component is 30 cm, the time coefficient (considering the time of stay during each activity) is 1.
- Master and technician – management of workers, control of exposure time (master), control of the cutting techniques, the quality and speed of the cut (technician) – the distance from the component is 100 cm, the time coefficient is 0.8.
- Radiation protection technician – monitoring radiological situation, measurement of dose rate – the distance from the component is 100 cm, the time coefficient is 0.3.

4.4. Dismantling Procedure

The proposed methodology of dismantling and fragmentation of the heat exchange tubes involves the use of hydraulic shears (crimp shear). The advantage of this technique is that the crushing effect of the cut closes the end of the tube in the form of two sealed lips.

This minimizes the risk of contaminants dispersion [1]. In other cases the dismantling and fragmentation is performed using plasma cutting tools. Due to higher aerosol dispersion during plasma cutting, in the case of dismantling and fragmentation of collectors the pressure suit is used.

The times required for accomplishing single steps were set as follows:

- The time needed for cutting the end parts (two hemispheres) and upper part of SG casing was derived from the cutting speed of the facility for fragmentation of large components in the Interim Storage North at the Greifswald site, which varies from 15 to 80 mm/min [22]. Within the conservative approach and since the procedure is performed in the controlled area, the lowest speed from the interval was chosen.
- The time required for fragmentation of each part of SG was calculated from the mass of component being fragmented and the work load which was approx. 7 man-hours/t for preparatory activities and 9 man-hours/t for fragmentation activities (except the fragmentation of the heat exchange tubes where the work load was increased to 15 man-hours/t – the use of hydraulic shears).

The work load was also increased in case of dismantling and fragmentation of collector due to use of pressure suit. These values of work load represent the fragmentation at the dimensions of transportable container (1×1×1.5 m).

The process of dismantling consists of the following consecutive steps:

- Construction of a shielding wall allowing better radiological conditions for fragmentation. Material of the shielding wall is iron, the wall dimensions are: height 3.5 m, length 10.7 m (to cover the area of heat exchange tubes), thickness 5 cm and the distance from the SG casing 2.5 m.

The work load considered for construction is 8 man-hours. The situation is depicted in Fig. 5. It has to be emphasized that the persons depicted in the following figures show only the points, where the dose rate was calculated, not the number of workers. The red persons represent trajectory of cutter and junior technician, the green persons represent trajectory of radiation protection technician together with master and technician.

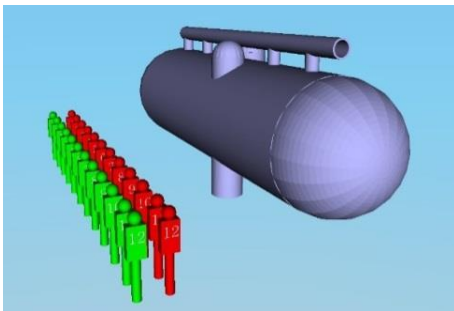

Fig. 5. Construction of shielding wall

- Cutting one end part and its transportation behind the shielding wall, then the same with other end part (after the fragmentation of the first one), total – 35 man-hours. The situation is depicted in Fig. 6.

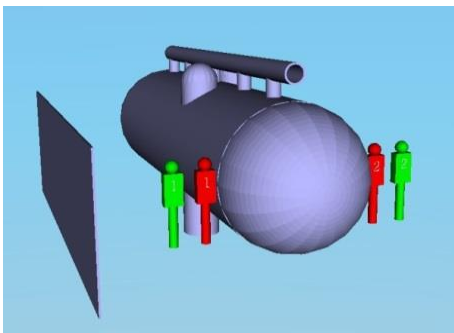

Fig. 6. Cutting the end part

- Fragmentation of SG body – preparatory activities, involving tool maintenance, breaks, etc., total value for the whole dismantling and fragmentation process is 300 man-hours.
- Fragmentation of end parts – total for both parts 140 man-hours. The situation is depicted in Fig. 7.

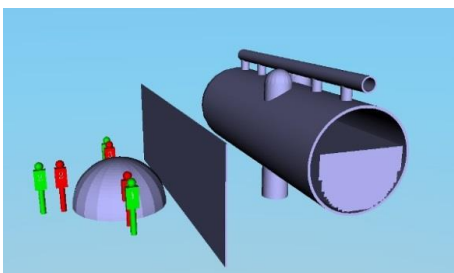

Fig. 7. Fragmentation of end part

- Cutting and taking out upper part of SG casing and its transportation behind the shielding wall, total – 110 man-hours.
- Fragmentation of upper part of SG casing – total 300 man-hours.
- Cutting and taking out the heat exchange tubes. This is considered to be done in 3 steps, after each step the transportation and fragmentation of the segment is carried out then the procedure is repeated with the next segment. The total work load for cutting and transportation of the heat exchange tubes is 50 man-hours. The situation is depicted in Fig. 8.

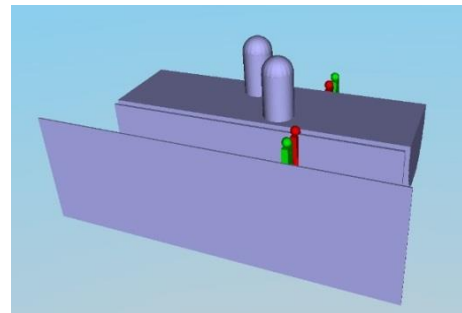

Fig. 8. Cutting and taking out the heat exchange tubes – first 1/3

- Fragmentation of one segment of the heat exchange tubes – approx. 165 man-hours each, total 500 man-hours. The situation is depicted in Fig. 9.

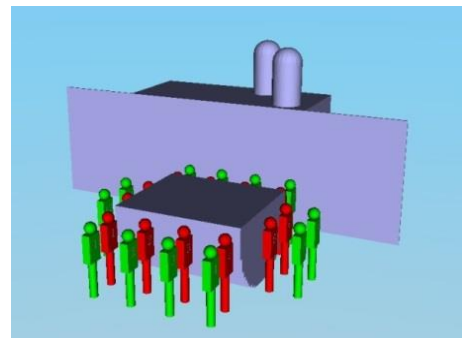

Fig. 9. Fragmentation of the heat exchange tubes – first 1/3

- Dismantling of collectors – preparation – 15 man-hours each, total 30 man-hours.
- Cutting and taking out the collectors – 6 man-hours each, total 12 man-hours.
- Fragmentation of collectors – approx. 160 man-hours each, total 320 man-hours. The situation is depicted in Fig. 10.

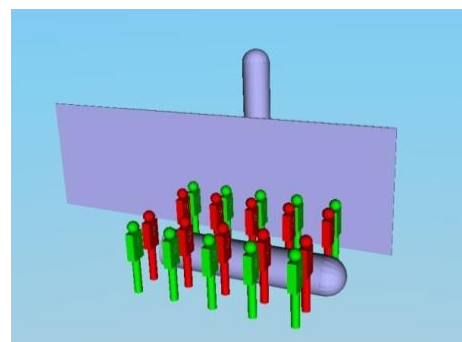

Fig. 10. Fragmentation of collector

Based on the assumptions stated in chapter Worker group, the general overview of task duration of each worker group is given in Table 2.

Table 2. General overview of total task duration of each worker group

Activity	Total task duration [manh]			Total [manh]
	Cutter and junior technician	Radiation protection technician	Master and technician	
Construction of shielding wall	4.1	0.6	3.3	8
Cutting and taking out the end parts	17.9	2.7	14.4	35
Fragmentation of SG body – preparation	153.8	23.1	123.1	300
Fragmentation of end parts	71.8	10.8	57.4	140
Cutting and taking out the upper part of SG casing	56.4	8.5	45.1	110
Fragmentation of upper part of SG casing	153.8	23.1	123.1	300
Cutting and taking out the heat exchange tubes	25.6	3.8	20.5	50
Fragmentation of the heat exchange tubes	256.4	38.5	205.1	500
Dismantling of collectors – preparation	15.4	2.3	12.3	30
Cutting and taking out the collectors	6.2	0.9	4.9	12
Fragmentation of collectors	164.1	24.6	131.3	320
Total [manh]	925.6	138.8	740.5	1805

Table 3. The influence of time decay on the activity content

Part of steam generator	0 years		5 years		10 years	
	Activity content [Bq]	Mass activity [Bq/kg]	Activity content [Bq]	Mass activity [Bq/kg]	Activity content [Bq]	Mass activity [Bq/kg]
Heat exchange tubes	7.29E+09	2.10E+05	4.33E+09	1.25E+05	3.24E+09	9.35E+04
Collector	7.08E+06	5.59E+02	4.21E+06	3.32E+02	3.15E+06	2.49E+02
Total	7.30E+09	-	4.34E+09	-	3.25E+09	-

4.5. Time Decay

The initial activity values are considered to date 1 January 2015. To investigate the influence of activity decrease (via radioactive decay) on the exposure of workers, the time periods of 0 (immediate start of dismantling), 5 and 10 years (dismantling close to the end of the 2nd stage of V1 NPP decommissioning process) are considered in the calculations. Among the decrease of activity level also the nuclide vector structure changes (based on the fact that the activity of nuclides with shorter half-lives (e.g. ^{110m}Ag) will decrease faster than in the case of nuclides with longer half-lives – e.g. ^{63}Ni).

The time dependence of the decrease of the activity level and mass activities of heat exchange tubes and collectors are depicted in Table 3.

5. Results of Calculations

The total collective effective dose of all workers is depicted in Table 4 and Fig. 11.

Table 4. Total collective effective dose – time dependence

Start dismantling	of	Total collective effective dose [manmSv]
2015		6.55E+00
2020		3.39E+00
2025		1.79E+00

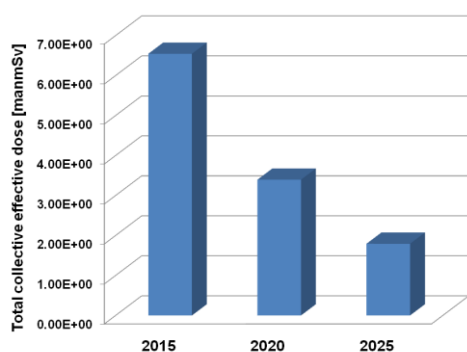

Fig. 11. The influence of time on the total collective effective dose

From the Table 4 and Fig. 11 it is obvious that the time period has a strong influence on the total collective effective dose. The time period of 5 years results in approx. twofold decrease, the doses after 10 years are approx. 3.7-times lower (related to the reference value – 0 years). When comparing these values with the decrease of activity (Table 3) the results are slightly different – the total activity is after 5 years approx. 1.7-times lower, after 10 years is approx. 2.2-times lower. This difference can be explained by the fact that ^{63}Ni is a long-lived radionuclide (half-life 96 a) and therefore the time periods considered have only little influence on its activity decrease. On the other hand, ^{63}Ni is a weak β^- emitter and relevant for internal exposure only [14]. The main contribution to the external exposure is from ^{60}Co (half-life 5.27 a) and ^{55}Fe (half-life 2.7 a). Therefore the time period of 5 years causes faster decrease of doses than the activity content.

To investigate the most critical tasks within the dismantling process together with worker group, the overview of results is given in Table 5, Table 6 and Table 7 together with Fig. 12 and Fig. 13.

Based on the data depicted in these tables and figures the following conclusions can be said:

- The highest contribution to the total dose (within each worker group) have the activities regarding cutting and taking out the heat exchange tubes and their fragmentation. This phenomenon can be expected due to the activity amount on the inner surface of heat exchange tubes which is approx. 3 orders of magnitude higher than in case of collectors. Moreover, the fragmentation of heat exchange tubes has the highest workload and therefore this activity has the major contribution to the total collective effective dose (Fig. 12).
- The highest exposure can be observed for cutter and junior technician. This is caused by the shortest distance from the component being cut (30 cm) together with the highest workload within each task (compared with other worker groups).
- From the Fig. 13 it can be also seen that the highest task dose (except cutting and taking out the heat exchange tubes and their fragmentation) is in case of cutting and taking out the upper part of SG casing. On the other hand, the fragmentation of the same part (with workload of more than 2.7-times higher) results in doses which are approx. 15-times lower than in case of cutting and taking out. This phenomenon can be explained by the fact that the cutting and taking out the upper part of SG casing is carried out in the vicinity of heat exchange tubes. In opposite to this, the fragmentation

activities are performed behind the shielding wall. This demonstrates the effect of constructed shielding wall on the reduction of exposure.

- In case of collectors the situation is different than the previous mentioned. The workload of cutting and taking out of 1 collector is approx. 13-times lower than in case of its fragmentation. Due to the fact that in this step the collectors are the only source of activity also the task dose in case of cutting and taking out will be approx. 13-times lower.
- When the task doses of worker groups (cutter and junior technician) vs. (master and technician) are compared (Table 5, Fig. 13), it can be said that in most cases the doses of worker group (cutter and junior technician) are approx. 1.6-times

higher. There are 2 exemptions – fragmentation of end parts and dismantling of collectors – preparation. The first case can be explained by the fact that this task is carried out behind the shielding wall where the dose rate level is very low (the activity of end part is negligible). Therefore in this situation the different distances and exposure times have only low influence on the increasing of doses. In case of preparation of dismantling of collectors the influence of different trajectory of workers can be seen.

The task doses of radiation protection technician are the lowest due to the distance and the lowest exposure time from all worker groups.

Table 5. Task doses for each activity and worker group – 2015

Activity	Task dose [manmSv]		
	Cutter and junior technician	Radiation protection technician	Master and technician
Construction of shielding wall	3.29E-04	4.09E-05	2.18E-04
Cutting and taking out the end parts	1.51E-03	2.21E-04	1.18E-03
Fragmentation of SG body – preparation	1.31E-03	1.77E-04	9.43E-04
Fragmentation of end parts	3.50E-04	7.23E-05	3.86E-04
Cutting and taking out the upper part of SG casing	9.71E-03	1.30E-03	6.96E-03
Fragmentation of upper part of SG casing	6.03E-04	8.60E-05	4.59E-04
Cutting and taking out the heat exchange tubes	2.24E-01	2.25E-02	1.20E-01
Fragmentation of the heat exchange tubes	4.05E+00	3.31E-01	1.77E+00
Dismantling of collectors – preparation	2.78E-03	7.62E-05	4.06E-04
Cutting and taking out the collectors	2.49E-04	2.40E-05	1.28E-04
Fragmentation of collectors	3.22E-03	3.42E-04	1.83E-03
Total [manmSv]	4.29E+00	3.56E-01	1.90E+00

Table 6. Task doses for each activity and worker group – 2020

Activity	Task dose [manmSv]		
	Cutter and junior technician	Radiation protection technician	Master and technician
Construction of shielding wall	1.72E-04	2.12E-05	1.13E-04
Cutting and taking out the end parts	7.90E-04	1.07E-04	5.71E-04
Fragmentation of SG body – preparation	6.98E-04	9.18E-05	4.90E-04
Fragmentation of end parts	1.75E-04	3.86E-05	2.06E-04
Cutting and taking out the upper part of SG casing	5.04E-03	6.89E-04	3.67E-03
Fragmentation of upper part of SG casing	3.05E-04	5.13E-05	2.74E-04
Cutting and taking out the heat exchange tubes	1.15E-01	9.95E-03	5.31E-02
Fragmentation of the heat exchange tubes	2.10E+00	1.73E-01	9.22E-01
Dismantling of collectors – preparation	3.54E-04	4.04E-05	2.15E-04
Cutting and taking out the collectors	1.26E-04	1.24E-05	6.61E-05
Fragmentation of collectors	1.66E-03	1.77E-04	9.47E-04
Total [manmSv]	2.23E+00	1.84E-01	9.82E-01

Table 7. Task doses for each activity and worker group – 2025

Activity	Task dose [manmSv]		
	Cutter and junior technician	Radiation protection technician	Master and technician
Construction of shielding wall	8.99E-05	1.11E-05	5.92E-05
Cutting and taking out the end parts	4.04E-04	5.86E-05	3.12E-04
Fragmentation of SG body – preparation	3.63E-04	4.75E-05	2.54E-04
Fragmentation of end parts	9.41E-05	1.95E-05	1.04E-04
Cutting and taking out the upper part of SG casing	2.68E-03	3.67E-04	1.96E-03
Fragmentation of upper part of SG casing	1.63E-04	2.50E-05	1.33E-04
Cutting and taking out the heat exchange tubes	6.00E-02	5.22E-03	2.78E-02
Fragmentation of the heat exchange tubes	1.11E+00	9.14E-02	4.88E-01
Dismantling of collectors – preparation	1.88E-04	2.11E-05	1.12E-04
Cutting and taking out the collectors	6.78E-05	6.69E-06	3.57E-05
Fragmentation of collectors	8.80E-04	9.35E-05	4.99E-04
Total [manmSv]	1.18E+00	9.73E-02	5.19E-01

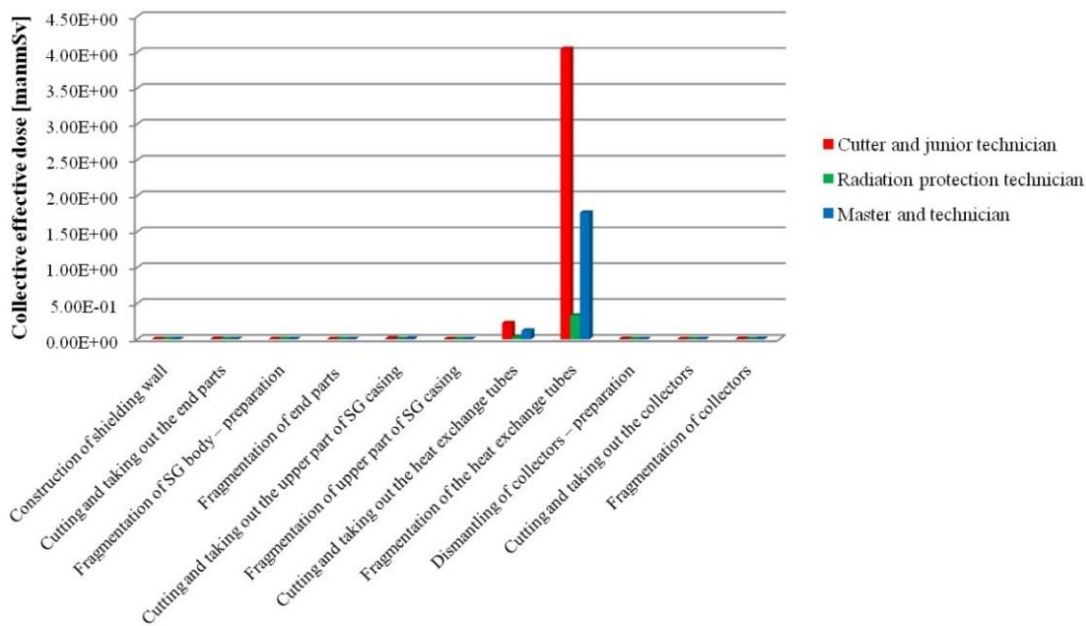

Fig. 12. Task doses – general overview – 2015

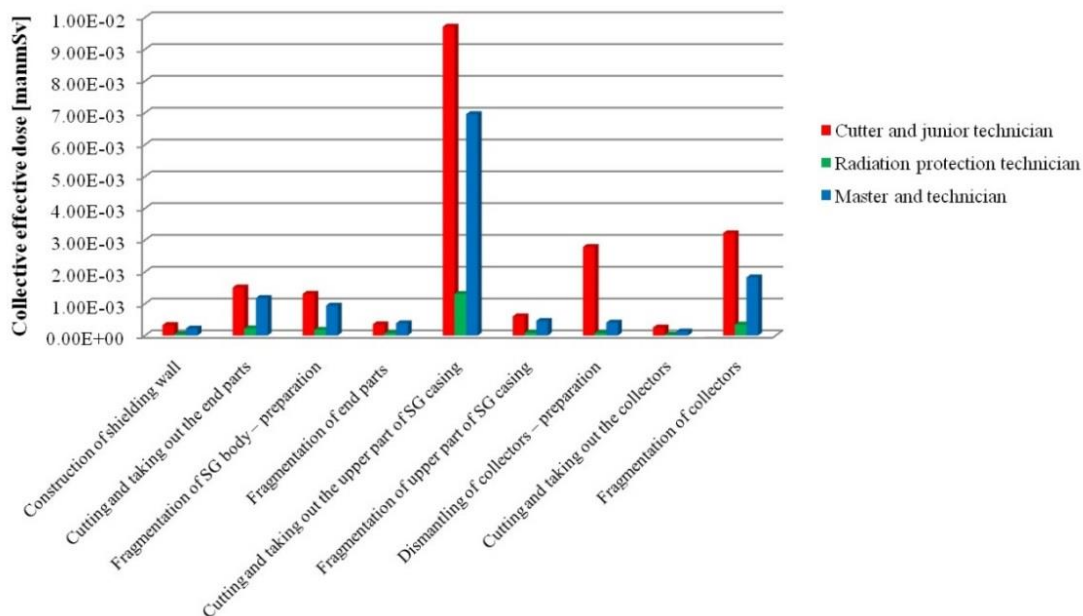

Fig. 13. Task doses – preparatory activities, cutting and fragmentation of SG casing and collectors – 2015

It has to be mentioned that the trends depicted in Fig. 12 and Fig. 13 are the same (together with consequences stated above) also for 5 and 10 years.

It is also necessary to emphasize that in the all studied cases the individual and collective effective doses are below the appropriate limits stated in [24].

6. Conclusion

The main aim of the paper was to analyze the process of dismantling of steam generator with emphasis on the calculation of external exposure. The created calculation model, considered dismantling strategy and worker group carrying out the dismantling and segmentation were presented. Also the degree of influence of time decay (0,5 and 10 years) on the total collective effective dose was investigated. The different distance and exposure time of workers during dismantling and segmentation was considered which allows the assessment of the contribution of each worker to the total collective effective dose.

It is necessary to emphasize that in all calculations the application of pre-dismantling decontamination with DF of 100 was considered. The possible absence of the decontamination would lead to increase of all the calculated values by 2 orders of magnitude but the main consequences stated in the paper would be the same. However, it can be said that the consideration of no decontamination is non-realistic due to the fact that this would lead to ineligious increase of task doses (which is in contradiction with the ALARA principle). Moreover, one of the advantages of decontamination is possible increase of the amount of materials which can be released into the environment or the declassification of radioactive waste. This phenomenon was partially studied in [10].

In general it can be concluded that the calculation results presented in this paper can be used for realistic planning and optimization of individual steps of the process of dismantling of steam generator.

7. Acknowledgments

This project has been partially supported by the Slovak Grant Agency for Science through grants VEGA 1/0796/13 and by the Ministry of Education by decree CD-2009-36909/39460-1:11 within the bounds of project CONRELMAT.

The authors want to thank cordially Dr. Peter Bezák from the company DECOM, a.s. Trnava for many fruitful discussions.

References

- [1] Bach F-W., Dufaud J-M., Lorin Ch.: Dismantling and Segmentation. EUR 16211 - Handbook on decommissioning of nuclear installations. Luxembourg: Office for Official Publications of the European Communities, 1995.
- [2] Barabáš K.: Nuclear power plants. Faculty of Electrical Engineering, Czech Technical University in Prague, 1985 (in Czech).
- [3] Bauerfeind M., Feinhals J.: The Disposal of Large Components Strategies. [online]. Available: <<http://www.iaea.org/OurWork/ST/NE/NEFW/IDN/Feinhals%20-%20202.pdf>>.
- [4] Beverungen M.: External Disposal of 4 Steam Generators out of the Decommissioning of the Nuclear Power Plant Stade (KKS). International Conference on Environmental Remediation and Radioactive Waste Management ICEM 2009, Liverpool, United Kingdom, October 11-15, 2009. ASME, 2009.
- [5] Borchardt R.: Dismantling of the Reactors on the Greifswald Nuclear Power Plant (KGR) Site. [online]. Available: <http://www.iaea.org/OurWork/ST/NE/NEFW/WTS-Networks/IDN/idnfiles/CuttingTechniqueWkp-Germany2011/EWN_Dismantling_of_the_reactors_on_the_Greifswald_Nuclear_Power_Plant_site.pdf>
- [6] Borchardt R.: Transport of the Reactor Pressure Vessels in the Greifswald Nuclear Power Plant. International Conference on Environmental Remediation and Radioactive Waste Management ICEM 2009, Liverpool, United Kingdom, October 11-15, 2009. ASME, 2009.
- [7] Federal Ministry for the Environment, Nature Conservation and Nuclear Safety. Joint Convention on the Safety of Spent Fuel Management and on the Safety of Radioactive Waste Management: Report of the Federal Republic of Germany for the fourth Review Meeting in May 2012. [online]. Available: <http://www.bmu.de/fileadmin/bmu-import/files/english/pdf/application/pdf/jc_4_bericht_deutschland_en.pdf>.
- [8] Geiger H., Schymke K.: Weltweite Logistik im gesamten Nuklear-Kreislauf: Nuclear Cargo + Service GmbH. International Journal for Nuclear Power, vol. 56, no. 3, 2011, 169-170.
- [9] Ghandour A.: Duratek Transports Reactor Pressure Vessel to Barnwell. [online]. Available: <http://media.corporate-ir.net/media_files/NSD/DRTK/reports/insite/34/rpv.html>.
- [10] Hornáček M., Nečas V.: The Analysis of the Process of Dismantling of Large Components used in Nuclear Power Plants from the Perspective of Radioactive Waste Disposal. Regional Seminar on Radioactive Waste Disposal, Senec, Slovakia, October 8 – 9, 2013. DECOM, a.s. Trnava, 2013.
- [11] Hrnčíř T., Nečas V.: Recycling and reuse of very low level radioactive steel in motorway tunnel scenario. Nuclear Engineering and Design, 265/2013, 534-541.
- [12] Hrnčíř T., Páňik M., Ondra F., Nečas V.: The impact of radioactive steel recycling on the public and professionals. Journal of Hazardous Materials, 254-255, 2013, 98-106.
- [13] International Atomic Energy Agency. Assessment and management of ageing of major nuclear power plant components important to safety: Steam generators, IAEA-TECDOC-981. Vienna, IAEA, 1997.
- [14] International Atomic Energy Agency. Radiological Characterization of Shut Down Nuclear Reactors for Decommissioning Purposes – Technical Reports Series No. 389. Vienna, IAEA, 1998.
- [15] Knaack M.: Dismantling of Large Components. [online]. Available: <http://www.iaea.org/OurWork/ST/NE/NEFW/WTS-Networks/IDN/idnfiles/WkpPlanLicencingDecompProjetc_Germany2012/WkpPlanLicencingDecompProjetc_Germany2012-Dismantling_Large_Components-Knaack.pdf>.
- [16] Loeb A., Stanke D., Kemp L.: Decommissioning of the reactor pressure vessel and its peripheral facilities of the Nuclear Power Plant in Stade, Germany – 11100. WM2011 Conference, Phoenix, Arizona, USA, February 27 – March 3, 2011.
- [17] Loeb A.: RDB Rückbau im Kernkraftwerk Stade: Innovative Umsetzung. International Journal for Nuclear Power, vol. 56, no. 3, 2011, 171-175.
- [18] National Nuclear Fund for Decommissioning of Nuclear Installations and for Spent Fuel and Radioactive Waste Management. Strategy of Back-end of Peaceful Use of Nuclear Energy in Slovak Republic, 2012 (in Slovak).
- [19] Nuclear and Decommissioning Company. The Intent in terms of the Act No. 24/2006 Coll. on Environmental Impacts Assessment and Alternations and Amendments of certain Acts as amended – The 2nd Stage of Decommissioning of V1 NPP Jaslovské Bohunice. [online]. Available: <<http://www.javys.sk/sk/ospolocnosti/projekty/posudenie-vplyvu-2-etapy-vyradovania-je-v1-na-zp/dokumenty>> (in Slovak).
- [20] Organization for Economic Co-operation and Development – Nuclear Energy Agency. Radioactive Waste Management Committee, The Management of Large Components from Decommissioning to Storage and Disposal: A report of the Task Group on Large Components of the NEA Working Party on Decommissioning and Dismantling (WPDD), NEA/RWM/R(2012)8, Paris, (2012), OECD/NEA.
- [21] Philipp M.: Die Energiewerke Nord GmbH – Der Weg vom Betreiber eines stillgelegten russischen Kernkraftwerkes zu einem führenden Stilllegungsunternehmen in Europa. International Journal for Nuclear Power, vol. 56, no. 3, 2011, 160-164.
- [22] Rohde M.: Treatment and Conditioning of Dismantled Material and Operation Waste in EWN, Overview. [online]. Available: <<http://www.iaea.org/OurWork/ST/NE/NEFW/WTS-Networks/IDN/idnfiles/CuttingTechniqueWkp-Germany2011/Treatment-and-Conditioning-of-DismantledMaterial-and-OperationWaste.pdf>>
- [23] Roupec P.: Transfer Heat Analysis in Steam Generators in Blocks of VVER 440. Master's thesis, Energy Institute, Faculty of Mechanical Engineering, Brno University of Technology, 2010 (in Czech).
- [24] Statutory Order No. 345/2006 on the Basic Safety Requirements on Personnel and Public Health Protection against Ionizing Radiation (in Slovak). Government of Slovak Republic, 2006.
- [25] Steiner H., Eickelpasch N., Tegethoff H.: Experience with the dismantling of three secondary steam generators in unit A Gundremmingen by the 'ice sawing' technique. Nuclear Engineering and Design, vol. 170, 1997, 165-173.
- [26] Stjepani Ch.: Full System Decontamination (FSD) prior to Decommissioning. Proceedings of the ASME 2011 14th International Conference on Environmental Remediation and Radioactive Waste Management ICEM2011, Reims, France, September 25-29, 2011. ASME, 2009.
- [27] Tatranský P., Nečas V.: Conditional release of materials from decommissioning process into the environment in the form of steel railway tracks. Nuclear Engineering and Design, 239, 2009, 1155-1161.
- [28] Topf Ch., Belda L. S., Fischer M., Tscheschlok K., Volkman Ch.: Full System Decontamination at German Nuclear Power Plant Unterweser. International Journal for Nuclear Power, atw Vol. 58, 2013, 216-220.
- [29] Vermeersch F.: Dose Assessment and ALARA Calculation with VISIPLAN 3D ALARA Planning tool. Training Course, IDPBW Nuclear Studies, Boerentang: SCK.CEN, Belgium, 2005.
- [30] Walberg M., Viermann J., Beverungen M., Kemp L., Lindström A.: Disposal of Steam Generators from Decommissioning of PWR Nuclear Power Plants. IYNC 2008, Interlaken, Switzerland, 20-26 September 2008, 158.1-158.10.
- [31] Weil L., Rehs B.: Nuclear Power Plant Decommissioning in Germany – Projects, Regulation and Experience. International Conference on Environmental Remediation and Radioactive waste management ICEM 2009, Liverpool, United Kingdom, October 11-15, 2009. ASME, 2009.
- [32] Wheeler D. M.: Large Component Removal/Disposal. WM'02 Conference, Tucson, Arizona, USA, February 24-28, 2002. [online]. Available: <<http://www.wmsym.org/archives/2002/Proceedings/44/573.pdf>>.

M.Sc. Martin Hornáček
e-mail: martin.hornacek@stuba.sk



He was born in Bratislava in the Slovak Republic, on July 1, 1986. He graduated from the Slovak University of Technology in Bratislava in 2012. His field of study was nuclear power-engineering. His employment experience included 7 months practice in DECOM, a.s. company in Trnava. His special fields of interest include radioactive waste management. At present he is a PhD student at the Slovak University of Technology in Bratislava, Faculty of Electrical Engineering and Information Technology. The topic of his study at the Institute of Nuclear and Physical Engineering is decommissioning of nuclear installations and radioactive waste management.

Prof. Vladimír Nečas
e-mail: vladimir.necas@stuba.sk



He was born in Slovakia in 1954, graduated from the Faculty of Electrical Engineering, Slovak University of Technology in Bratislava in 1979 and received the PhD. degree in 1990 in Experimental Physics. From 1993 he worked as Assoc. Professor, and since 2001 he has been Professor at the Department of Nuclear Physics and Technology, at the same university and faculty. At present the main fields of his research and teaching activities include experimental nuclear physics, nuclear reactor materials, problems of spent nuclear fuel and decommissioning of nuclear facilities.

otrzymano/received: 2014.08.22

przyjęto do druku/accepted: 2014.09.12