



Phylogeny of the orb-web building spiders (Araneae, Orbiculariae: Deinopoidea, Araneoidea)

CHARLES E. GRISWOLD^{1*}, JONATHAN A. CODDINGTON²,
GUSTAVO HORMIGA³ AND NIKOLAJ SCHARFF⁴

¹*Department of Entomology, California Academy of Sciences, Golden Gate Park, San Francisco, CA 94118, U.S.A.*; ²*Department of Entomology, National Museum of Natural History, NHB-105, Smithsonian Institution, Washington, D.C. 20560, U.S.A.*; ³*Department of Biological Sciences, George Washington University, Washington, DC 20052, U.S.A.*; ⁴*Zoological Museum, Universitetsparken 15, Copenhagen, Denmark*

Received February 1996; accepted for publication January 1997

This phylogenetic analysis of 31 exemplar taxa treats the 12 families of Araneoidea (Anapidae, Araneidae, Cyatholipidae, Linyphiidae, Mysmenidae, Nesticidae, Pimoidae, Symphytognathidae, Synotaxidae, Tetragnathidae, Theridiidae, and Theridiosomatidae). The data set comprises 93 characters: 23 from male genitalia, 3 from female genitalia, 18 from cephalothorax morphology, 6 from abdomen morphology, 14 from limb morphology, 15 from the spinnerets, and 14 from web architecture and other behaviour. Criteria for tree choice were minimum length parsimony and parsimony under implied weights. The outgroup for Araneoidea is Deinopoidea (Deinopidae and Uloboridae). The preferred shortest tree specifies the relationships ((Uloboridae, Deinopidae) (Araneidae (Tetragnathidae ((Theridiosomatidae (Mysmenidae (Symphytognathidae, Anapidae))) (Linyphiidae, Pimoidae) ((Theridiidae, Nesticidae) (Cyatholipidae, Synotaxidae)))))). The monophyly of Tetragnathidae (including metines and nephilines), the symphytognathoids, theridiid-nesitic lineage, and Synotaxidae are confirmed. Cyatholipidae are sister to Synotaxidae, not closely related to either the Araneidae or Linyphiidae, as previously suggested. Four new clades are proposed: the cyatholipoids (Cyatholipidae plus Synotaxidae), the 'spineless femur clade' (theridioid lineage plus cyatholipoids), the 'araneoid sheet web builders' (linyphioids plus the spineless femur clade), and the 'reduced piriform clade' (symphytognathoids plus araneoid sheet web builders). The results imply a coherent scenario for web evolution in which the monophyletic orb gives rise to the monophyletic araneoid sheet, which in turn gives rise to the gumfoot web of the theridiid-nesitic lineage. While the spinning complement of single pairs of glands does not change much over the evolution of the group, multiple sets of glands are dramatically reduced in number, implying that derived araneoids are incapable of spinning many silk fibers at the same time.

© 1998 The Linnean Society of London

ADDITIONAL KEY WORDS:—evolution – webs – cladistics – systematics – comparative morphology – homology.

* Correspondence to Dr C. E. Griswold. Email: griswold@cas.calacademy.org

CONTENTS

Introduction	2
Material and methods	3
Conventions	3
Abbreviations	3
Taxon choice	4
Character definitions	4
Specimen preparation	4
Vouchers	5
Cladistic analysis	5
Taxa	6
The outgroup: Deinopoidea	6
The ingroup: Araneoidea	7
Characters for phylogenetic analysis of Orbiculariae	15
Character polarities	16
Results: phylogeny of Orbiculariae	16
Discussion	20
Acknowledgements	24
References	26
Appendix 1: Character list, optimizations and evolution	30
Appendix 2: Character state matrix	46
Appendix 3: Taxa examined to provide exemplar data	50
Figures	52

INTRODUCTION

The Araneoidea comprise the largest and best known superfamily of spiders. To many observers, the symmetrical orb webs spun by many members of this group epitomize engineering skill and natural beauty. By the same token, the fearsome reputation of the widow spiders (*Latrodectus*, Theridiidae) for deadly venom and cannibalism during mating symbolizes everything that people dislike about spiders. The 12 families included in this superfamily contain nearly 10 000 described species (Platnick, 1989). Individually, the Linyphiidae and Araneidae rank second and third (after Salticidae) in terms of numbers of described species. The Araneoidea have been the subject of numerous studies and copious speculation regarding the evolution of web building, predatory, and sexual behaviour, much of which could benefit from the organization and perspective that a well supported phylogeny provides.

The monophyly of the Araneoidea and of Orbiculariae (Araneoidea + Deinopoidea) has been extensively tested (Coddington, 1986a, 1989, 1990a, b). It remains the simplest explanation for the empirical evidence assembled to date. Although there have been several other proposed phylogenies for the Araneoidea, these have not been based on thorough descriptions of objective character definitions and criteria for character state polarization (e.g. Levi, 1980b; Heimer & Nentwig, 1982; Wunderlich, 1986). Studies using more rigorous methods were still unable to place either Linyphiidae or Theridiidae-Nesticidae unambiguously (Coddington, 1986a, 1990a, b). None of these previous studies included the poorly known, largely southern hemisphere families Cyatholipidae and Synotaxidae.

In this study we attempt to remedy the weaknesses of these previous studies. This data set comprises exemplar representatives from each of the 12 families of Araneoidea (Anapidae, Araneidae, Cyatholipidae, Linyphiidae, Mysmenidae,

Nesticidae, Pimoidae, Symphytognathidae, Synotaxidae, Tetragnathidae, Theridiidae, Theridiosomatidae) and the two families of the outgroup Deinopoidea (Deinopidae and Uloboridae). We critically evaluate the data and homology hypotheses used in these previous studies, and add several new characters from behaviour, web form and genitalic and somatic morphology, especially spinnerets and silk spigots.

MATERIAL AND METHODS

Conventions

Throughout the text, figures cited from previous papers are listed as ‘fig.’, those appearing in this paper as ‘Fig’. The figures are grouped at the end of the paper, pp. 52–99. The following abbreviations for persons and institutions are used: CAS (California Academy of Sciences, San Francisco), CG (Charles Griswold), GH (Gustavo Hormiga), JC (Jonathan Coddington), NS (Nikolaj Scharff), USNM (National Museum of Natural History, Smithsonian Institution, Washington, D. C.), and ZMUC (Zoological Museum, University of Copenhagen). Anatomical abbreviations used in the text and figures are listed in Abbreviations.

Abbreviations

A	alveolus	oL1	outside leg 1
AC	aciniform gland spigot(s)	oL4	outside leg 4
AG	aggregate gland spigot(s)	PC	paracymbium
ALS	anterior lateral spinneret	PCS	pimoid cymbial sclerite
AME	anterior median eyes	PEP	pimoid embolic-tegular process
BH	basal haematodocha	PI	piriform gland spigot(s)
C	conductor	PLE	posterior lateral eyes
CB	cymbium	PLS	posterior lateral spinneret
CL	column (stalk)	PME	posterior median eyes
CY	cylindrical gland spigot(s)	PMS	posterior median spinneret
E	embolus	PP	cyatholipid parembolic process
EM	embolic membrane	RMP	retromedian cymbial process
F	fundus	SEM	scanning electron microscope
FL	flagelliform gland spigot(s)	SP	secondary process of paracymbium
iL1	inside leg 1	SPT	suprattegulum
LC	lamella characteristic	SS	sticky silk
MA	median apophysis	ST	subtegulum
MAP	major ampullate gland spigot(s)	T	tegulum
mAP	minor ampullate gland spigot(s)	TA	terminal apophysis
MEA	metine embolic apophysis	TCA	theridiid cymbial apophysis
N	nubbin	TTA	theridiid tegular apophysis
NS	non sticky silk		

Taxon choice

Ideally, studies of higher classification should relate to one another the groundplans of the taxa treated: character variation within each taxon, insofar as it differs from the established primitive condition for that taxon, is irrelevant to the problem. In the context of this cladistic analysis we mean something specific by the ‘groundplan’ of a taxon: the list of optimized character states, or the ‘character vector’, of the basal node subtending the taxon. Obviously the character vector inferred may change if the taxon-character data matrix that produced it changes but, in general, cladistic analysis predicts that character values inferred for ancestral nodes will be robust under inclusion or exclusion of taxa or characters. We chose exemplar taxa (Appendix 3) whose character states were the same as the groundplan character vector of their higher taxon, as reconstructed by other phylogenetic analyses. At present groundplans that are ‘objective’ in this sense can be constructed only for the groups of spiders previously subject to a quantitative phylogenetic study. Where this was not possible, exemplar species were chosen to reflect the breadth of each family, which should maximize the chances of discovering homoplasy. The use of exemplar species involves only verifiable and observable data, rather than hypothetical states or character combinations. In those cases in which the limits of higher taxa are still dubious, the relationships suggested for exemplars should hold at least for monophyletic groups including the exemplar. Insofar as the exemplars truly represent their higher taxa, the set of interrelationships suggested should ultimately hold for those taxa. Specific choice of exemplars is discussed under each family.

Character definitions

Criteria for recognizing characters and defining their states are discussed and referenced, if appropriate, under each character below (see Appendix 1). We presume that all characters are logically independent, although perhaps not biologically. In other words, if variation in a structure is complex enough and sufficiently discrete that a number of comparisons can be made, we include them all. Character systems are represented in the matrix to the extent that comparisons about them can be made. This procedure amounts to weighting complex features more than simple ones.

With regard to apophyses on the tegulum of the male palp, we have arbitrarily chosen to allocate homoplasy in our data set to the median apophysis rather than to both it and the conductor (see characters 14 and 16 below; see also Coddington, 1990a). Spigots were classified according to the criteria in Coddington (1989) and advances since then. For example, where possible, identification of cylindrical gland spigots on the PMS and PLS were checked by their presence in females and absence in males.

Specimen preparation

Male palpi were expanded for all taxa by immersing them overnight in a 10–15% solution of potassium hydroxide (KOH) and transferring them to distilled water where expansion continued. Palpi were transferred back and forth between KOH

and distilled water until expansion stopped. Small structures were examined in temporary mounts following the procedure described in Coddington (1983). Examination was via Wild M5Apo and Leitz Ortholux II microscopes. Spinneret preparations were obtained most reliably when animals were quick-killed by sudden immersion in boiling water. Extension of the spinnerets provided a clear view of all spigots. If live material was unavailable, clean museum material was chosen; the specimen was ultrasonically cleaned, the abdomen was squeezed with forceps to extend and separate the spinnerets (Coddington, 1989: 73) if necessary, and the specimen was passed through changes from 75% to 100% ethanol. Prior to examination with a Hitachi S-520 or Cambridge Stereoscan SEM palpi and spinnerets were critical-point-dried; all other structures were air dried.

Vouchers

Voucher specimens representing these exemplar taxa (Appendix 3), labelled “Exemplar, Griswold, *et al.* Araneoidea study, 1996”, are deposited in the California Academy of Sciences and/or Smithsonian Institution.

Cladistic analysis

This data set (Appendix 2) comprises 93 characters (23 from male genitalia, 3 from female genitalia, 18 from cephalothorax morphology, 6 from abdomen morphology, 14 from limb morphology, 15 from the spinnerets, and 14 from web architecture and other behaviour) scored for 31 taxa. Multistate characters (11 out of a total of 93 characters; Appendix 2) were treated as non-additive (unordered), in which the minimum distance between all pairs of states could range as low as one step. In unordered characters it is character congruence that determines the state order; no *a priori* (non-falsifiable) hypotheses about order are constructed (Hauser & Presch, 1991). A more detailed justification for our preference for non-additive coding can be found in Hormiga (1994a).

We analysed the data to obtain trees of minimal length using Hennig86 1.5 (Farris, 1988), PAUP 3.1.1 (Swofford, 1993), and NONA 1.15 (Goloboff, 1994), and using Pee-Wee 2.15 (Goloboff, 1994) to obtain trees that maximize implied weights across all characters (‘fittest’ *sensu* Goloboff, 1993). In Hennig86 we used the **t;bb***; and **m*;bb***; commands, repeating each routine 10 times after shuffling the input order of taxa each time by hand. With PAUP a heuristic solution was sought under the following parameters: random taxon addition for 50 replicates, tree-bisection-reconnection branch-swapping performed, MULPARS in effect. Tree searches in NONA used the parameters **HOLD 1000**, **HOLD/500**, **AMB =**, and **MULT*200**. All analyses gave the same result: a single tree of 170 steps with a consistency index of 0.64 and a retention index of 0.81. This tree was fully resolved and is presented as Figures 7–9 (all figures grouped at end of paper). This result was stable under successive character weighting (Farris, 1969; Carpenter, 1988). Pee-Wee maximizes ‘implied weights’ to find trees that “resolve character conflict in favour of the characters that have less homoplasy on the trees and imply that the average weight for the characters is as high as possible” (Goloboff, 1993). The parameters **HOLD 1000**, **HOLD 500**, **HOLD/200**, **AMB =**, and **MULT*500** found one ‘fittest’ tree

(fit = 791.1), identical to that found by unweighted parsimony and under successive weighting. Consequently, we feel that Figures 7–9 provide the best explanation for these data, and use them to discuss character evolution and evolution of Araneoidea.

We used MacClade 3.0 (Maddison & Maddison, 1992) and Clados 1.2 (Nixon, 1992) to optimize characters on the tree. If optimizations were ambiguous, we usually resolved them using the ACCTRAN option (Farris optimization), which favours secondary loss over convergence to explain homoplasy and therefore maximizes homology. In a few cases, ACCTRAN was not sufficient to specify the location of changes, in which case we choose an optimization that reflected other more detailed studies of araneoid clades. Character optimizations and evolution are discussed below (Appendix 1).

TAXA

The following sections briefly describe the diversity and notable features of the taxa under study, mentioning significant or new comparative data about them where appropriate.

The outgroup: Deinopoidea

The cribellate orb-web builders of the superfamily Deinopoidea remain the most logical choice as the sister group of the Araneoidea (Coddington, 1986a, 1989, 1990a; Platnick *et al.*, 1991; Peters, 1992). Currently the Deinopoidea comprise two families: Deinopidae and Uloboridae. The spinning organs of deinopoids are fairly consistent. The ALS has numerous PI spigots with large bases. The PMS has an anterior brush of paracribellar spigots with elongate, closely annulate shafts; the single mAP spigot is median to anterior in position. The PMS and PLS have many AC spigots and several CY spigots; a conspicuously large, often isolated spigot near the apex of the PLS is presumed to serve the pseudoflagelliform gland.

Deinopidae

This family, comprising 56 named species in 4 genera (Platnick, 1989), is often called the ‘ogre faced spiders’ for the greatly enlarged PME of some species, and ‘retarius’ or ‘net-casting’ spiders after the unique predatory behaviour, which involves ensnaring the prey with the capture web stretched between legs I and II. Deinopids are large to very large spiders that build highly modified orb webs (Coddington, 1986b). The PME may be greatly enlarged (*Deinopsis*) or about equal to the PLE (*Menneus*). The male palpus is simplified, having only a single central tegular process, probably the conductor.

The spinning organs of *Deinopsis* were illustrated by Coddington (1989, figs 2–5) and Peters (1992, figs 1–6). Notably, the ALS has multiple MAP spigots, a feature rare among araneomorph spiders. *Menneus* spinnerets are similar.

The Deinopidae are currently being revised (Opell & Coddington, in prep.) but the study has not reached the stage of analysis. *Deinopsis spinosus* should accurately reflect the family groundplan for the characters used in this study.

Uloboridae

This family currently contains about 250 species in 20 genera (Platnick, 1989). Uloborids are the only spiders that build typical orb webs with cribellate capture lines, although some genera make webs reduced to a single sticky line (*Miagrammopes*; Lubin, 1986). Uloborids are small to medium-sized spiders that lack poison glands, have trichobothria on femur IV, and double the tertiary radii during orb construction (Eberhard, 1982; Coddington, 1986a).

The spinning organs of Uloboridae have been extensively studied (*Octonoba octonarius*: Coddington, 1989, figs 6–9; *Uloborus*: Kooor, 1978, Peters, 1983, 1984; Peters & Kooor, 1980, 1989). Unlike deinopids but like araneoids, the ALS has a single MAP spigot accompanied by a nubbin. The PI spigots of the ALS have sharp apical margins.

The genera and tropical American species were revised by Opell (1979), and Coddington (1990a) presented a cladogram for the genera as part of his study of orbicularian relationships, based mainly on Opell's data. For the characters used here, *Uloborus* reflects the family groundplan and is used as the exemplar.

The ingroup: Araneoidea

The spinning complement of araneoids differs from most other spiders (Kooor, 1987; Coddington, 1989; Platnick *et al.*, 1991) and is consistent enough that, with experience, it is often possible to identify a spider as an araneoid by its spinnerets alone. Unless otherwise noted, the taxa discussed below agree with the following description. The ALS has a single MAP spigot plus nubbin accompanied by few to many PI spigots; the PI spigot bases are short and in some families are reduced dramatically. The PMS has an anteromedian CY spigot and posterior (not median or anterior) mAP spigot, the latter typically with one accompanying nubbin. The PMS AC spigots vary from few to many; in the latter case they may form a 'brush' (Fig. 48C) extending down the anterior face of the spinneret that can spin many aciniform silk lines simultaneously, for example to wrap prey during attack or afterwards, to decorate the web, or perhaps during egg case production. The PLS has a 'triplet' of one FL and two AG spigots accompanied by few to many AC spigots and two CY spigots. All CY spigots are absent in males. The colulus is usually a triangular, fleshy lobe.

The triplet may be lost in spiders that no longer make webs (e.g. kleptoparasitic mysmenids, Fig. 29D), but is frequently retained, at least in part. Kleptoparasitic *Argyrodes* retain the triplet (Forster, Platnick & Coddington, 1990, fig. 358). The Australian araneid *Arkys*, which makes no orb and spins at most a single non-viscid frameline (Main, 1982), retains the two AG spigots (Platnick & Shadab, 1993; Scharff & Coddington, 1997). Absence of the triplet may be taken as strong evidence against araneoid affinity.

Anapidae

These small to minute, often armour-plated spiders were considered part of the large family Symphytognathidae prior to its relimitation by Forster and Platnick (1977). Platnick and Shadab (1978b) suggested that the Anapidae be restricted to a monophyletic group characterized by the presence of an anterior spur on the labrum

(Fig. 20C). The temperate South American and Australasian Anapidae have recently been monographed (Platnick & Forster, 1989). The family is moderate-sized, with nearly 150 species assigned to the more than 30 genera (Platnick, 1989), and still imperfectly known; it is nearly cosmopolitan though the vast majority of species occur in the tropical and south temperate parts of the world.

The webs of only a few anapids are known. Some, like the Chilean *Novanapis* and *Crassanapis*, may make no webs (Platnick *et al.*, 1991: 61); others make orbs with out-of-plane radii forming a cone above the centre of the web, e.g. *Anapis heredia* (Coddington, 1986a, fig. 12.16), *Anapisona simoni* (Fig. 3D; Coddington, 1986a, fig. 12.15), *Caledanapis tillierorum* (Platnick & Forster, 1989, figs 1, 2), and *Gertschanapis shantzi* (Coddington, 1986a, fig. 12.17, as *Chasmocephalon s.*).

The spinning organs of *Novanapis spinipes* (Platnick *et al.*, 1991, figs 249–256) and *Crassanapis chilensis* (Platnick *et al.*, 1991, figs 291–296) have been previously studied, but, as the spigot complement of these species may be reduced in concert with loss of the web-building lifestyle (Platnick *et al.*, 1991: 61), we decided to study the spinnerets of taxa known to make typical anapid webs. We present SEM micrographs of an exemplar male and female of *Gertschanapis shantzi* from California (Figs 33A–D, 34A–D) and a species of *Anapis* from Bolivia (Figs 31A–D, 32A–D), all specimens observed, collected, and prepared by ourselves. These anapids differ from the general araneoid description given above in having 7 to 12 PI spigots with highly reduced bases; one AC spigot on the PMS and two PMS nubbins. The PLS has the araneoid triplet of one FL and two AG spigots (not identified in *Novanapis* or *Crassanapis*); the triplet appears to be retained in males. The PLS have two (*Gertschanapis*) to four (*Anapis*) AC spigots. The basal CY is situated on an enlarged base separated from the rest of the spinning field by a deep groove. The colulus of *Gertschanapis* is the usual triangular, fleshy lobe; that of *Anapis* is lost or hidden by the sclerotized ring surrounding the spinnerets.

Araneidae

The common orb weavers are among the best known spiders. Araneidae comprise one of the largest spider families, with approximately 2600 described species in roughly 160 genera (Platnick, 1989): recent revisions of Neotropical araneids suggest that the global araneid species richness is much higher than the 2600 species presently known, with perhaps 6–7000 species estimated to exist (Coddington & Levi, 1991). Most build typical orb webs (Fig. 1C), but web modification and reduction occur in many lineages. The legs are spiny, the clypeus usually low, and the male palpus typically complex, with a conductor and median apophysis and usually with a subdivided embolic division.

The spinning organs of Araneidae (Fig. 48A–D) are well known (e.g. Kooor, 1987 (and references cited therein); Coddington, 1989, figs 10–21; Yu & Coddington, 1990). The ALS generally has from several to more than 100 PI spigots; the PI spigot bases are short but not reduced to the degree found in symphytognathoids and sheet web weavers. The PMS AC spigot brush has dozens to more than 100 spigots. The PLS has numerous AC spigots that surround the two similarly-sized CY spigots.

Araneidae have been the subject of much descriptive work and a target of considerable phylogenetic and evolutionary speculation (see summary in Scharff & Coddington, 1997). These authors have recently made an effort to understand the

phylogeny of the entire family, undertaking a quantitative cladistic study including exemplars from 57 araneid genera of 8 subfamilies and 19 (out of 26) tribes, and 13 genera from 5 outgroup families. Based upon provisional results from that study, we have chosen exemplar araneids, *Metepeira* and *Argiope*, to reflect the hypothetical araneid groundplan.

Cyatholipidae

First proposed as a family level taxon by Simon (1895), this small group of 11 genera and about 30 species is today restricted to the southern hemisphere (Griswold, 1987b; Forster, 1988). Wunderlich (1994) has recently described some spiders attributed to this family from Baltic amber.

These spiders are small in stature and, where known, hang beneath sheet webs (Figs 4D, 5A–C; Davies, 1978, Griswold, 1987b, Forster, 1988; JC, CG, GH, and NS, pers. obs.). The sternum is truncate posteriorly (Fig. 21C), the legs spineless, and the posterior tracheae open into a broad spiracle (Fig. 23B) (sometimes considered paired spiracles connected by an external groove, i.e. Forster, 1988). The palpus has a small, retrolateral paracymbium that is concave dorsally (Figs 17A,C,D, 18A, B): the ‘bipartite paracymbium’ frequently cited in the literature confuses this structure and a second, unique lateral process on the cymbium. The male palpus (Figs 17A,B, 19A) has a single, simple median process that is probably the conductor; the embolus may or may not have a subterminal parembolic process. The cymbial morphology and posterior respiratory system have been recognized as synapomorphies for the family.

The spinnerets of Cyatholipidae have not been described in detail, though a photograph of a juvenile *Cyatholipus* appeared in Griswold (1987b, fig. 18). Coddington (1990a), based on observation of one specimen of *Ulwembua outeniqua*, suggested FL and AG spigots may be lacking. We here report in detail on cyatholipid spinnerets and present SEM micrographs of *Tekella absidata* from New Zealand as an exemplar of the family (Figs 46A–D, 47A–D). This taxon differs from the general araneoid description presented above by having 12–14 PI spigots with highly reduced bases; the PMS has 2 AC spigots, and a posterior mAP spigot without an accompanying nubbin. The PLS has two AC spigots and the mesal CY spigot; the basal CY spigot is absent in females examined to date. Males retain the araneoid triplet.

An undescribed species from Mount Cameroon in West Africa which, by virtue of a second process associated with the conductor is attributed to the genus *Isicabu*, was chosen as an additional exemplar. Exemplars were chosen for the abundance of material for preparation and to include species with both round and triangular abdomens. *Cyatholipus*, the type genus for the family, was not chosen because its web is unknown: in all other characters scored in this matrix *Cyatholipus* is identical to *Tekella*.

Linyphiidae

The Linyphiidae are one of the most diverse spider families, containing more than 440 described genera and over 3600 species described up to 1987 (Platnick, 1989), and are worldwide in distribution. They range from minute to medium sized and are long-legged spiders with at least femoral spines, lateral striae on the chelicerae, patella-tibia autospasy, and generally hang beneath sheet webs (Figs 4B, 5D).

Merrett (1963) offered a detailed account of the taxonomic history of Linyphiidae, Millidge (1980) discussed some more recent developments, and Hormiga (1993, 1994a) provided a phylogenetic study of the family based on nine exemplar genera from each of the four subfamilies and seven outgroup taxa, representing three families. In this study, Hormiga suggested five linyphiid synapomorphies that he considered strong: lack of the araneoid median apophysis and conductor, an intersegmental paracymbium that is U or J-shaped, and the radix (upon which insert the lamella characteristica and terminal apophysis) and column on the male palp (Fig. 13C).

The spinnerets of linyphiids have been described and illustrated several times (Coddington, 1989, figs 38–41, *Frontinella*; Peters & Kooor, 1991, *Linyphia triangularis*; Hormiga, 1994a, *Stemonyphantes*, fig. 20, *Novafroneta*, fig. 21, *Haplinis*, fig. 22, *Walckenaeria*, fig. 23, *Erigone*, fig. 24, *Linyphia*, fig. 25, *Microlinyphia*, fig. 26, *Bolyphantes*, fig. 27, and *Lephtlyphantes*, fig. 28) and the spigot pattern is typically araneoid. The ALS has several to more than 30 PI spigots with reduced bases. The PMS posterior mAP spigot lacks accompanying nubbins. Usually only two PMS AC spigots are present, but in *Stemonyphantes* and at least some *Afroneta* the PMS AC spigots are lost, a condition paralleled in derived pimoids. Nevertheless, PMS AC spigots are present in the linyphiid groundplan. The PLS has the araneoid triplet (except in *Drapetisca*), accompanied by one to several AC spigots and two CY spigots. Typically linyphiine males lose the triplet, erigonines retain it. Both CY spigots are at the periphery of the PLS spinning field, and the basal spigot is on a greatly enlarged base.

We used Hormiga's (1994a) phylogeny to reconstruct the groundplan for the family. The exemplar, *Linyphia triangularis*, accurately reflects that groundplan for characters used here.

Mysmenidae

Considered part of the Symphytognathidae prior to that family's relimitation by Forster and Platnick (1977), the Mysmenidae remain poorly understood. Platnick and Shadab (1978a: 5) suggested male metatarsal clasping spines (Griswold, 1985, figs 12, 19, 20), lobes or apophyses on the cymbium (Fig. 11A; Gertsch, 1960, fig. 55; Platnick & Shadab, 1978a, fig. 17; Griswold, 1985, figs 14, 15, 26), and a ventral sclerotized spot on the female femur I (Fig. 10G; Griswold, 1985, fig. 22) as potential mysmenid synapomorphies. No comprehensive study of the family has been attempted, and it is not known if all of the 22 genera and nearly 90 species attributed to the Mysmenidae (Platnick, 1989) have these synapomorphies. The family contains small to minute spiders; it is nearly cosmopolitan but most species occur in the tropical and south temperate regions.

Webs are known for several species of Mysmenidae. *Maymena ambita* builds orbs with out-of-plane radii forming a cone above the centre of the web (Fig. 3A; Coddington, 1986a, fig. 12.22), nearly identical to the typical webs of Anapidae. *Mysmena* species construct a spectacular, egg-shaped, three-dimensional orb that results from a proliferation of out-of-plane radii (Fig. 3B; Eberhard, 1987a; Coddington, 1986a, figs 12.19–12.21). Members of the genera *Isela*, *Kilifia*, and *Mysmenopsis*, which live as kleptoparasites in the webs of mygalomorphs and other spiders, are not known to build webs of their own.

The spinning organs of Mysmenidae have not been studied in detail. We present SEM micrographs of two web-building species, *Maymena mayana* from Mexico (Fig.

26A,B) and an undetermined species attributed to *Mysmena* from Australia (Figs 27A–D, 28A–D), and of a kleptoparasitic undetermined species of *Isela* from Cameroon (Figs 29A–D, 30A–D). *Maymena* and *Mysmena* have typical araneoid spigot patterns. The ALS in *Mysmena* at least, has a large tartipore near the MAP and nubbin; the 7–14 PI spigots have highly reduced bases. The PMS has two AC spigots, and a large nubbin (Fig. 27C). The PLS araneoid triplet is retained in the male of *Mysmena* (Fig. 28D). Both sexes of *Mysmena* have a row of four PLS AC spigots, and the female of *Maymena* has a row of at least 10 (Fig. 26B). Although *Isela* (and the related South American *Mysmenopsis penai*) are not included in this matrix, the ALS and PMS complements of these kleptoparasites are like those of free-living species but the PLS differ. The araneoid triplet is absent from their PLS (Figs 29D, 30D); the kleptoparasitic lifestyle may have occasioned the loss of the ability to spin sticky silk.

We chose the exemplars *Maymena* and *Mysmena* to encompass the range of known web architecture in the family and to include the type genus of the family.

Nesticidae

This moderate-sized (7 genera with less than 200 species: Platnick, 1989) but cosmopolitan family is like the Theridiidae in habits, web (Fig. 2C), and morphology (see below), with the exception that nesticids retain a large and often complex basal paracymbium (Fig. 14A).

The spinnerets of Nesticidae are well known: *Gaucelmus angustinus* was described by Coddington (1989, figs 34–37); *Nesticus sheari* (Forster *et al.*, 1990, figs 339–342) and *N. cellulanus* (Forster *et al.*, 1990, fig. 372) and *Eidmanella pallida* (Forster *et al.*, 1990, fig. 374) were illustrated subsequently. The ALS has about 20 PI spigots with highly reduced bases; the PMS has one to few AC spigots; at least *Gaucelmus* has a posterior PMS nubbin. The PLS resembles that of theridiids in that the AG spigots are enlarged; however they are not laterally compressed.

We have chosen *Nesticus*, type genus of the family, as the exemplar. Nesticidae is scored accordingly except that we also score the PMS posterior nubbin as present for Nesticidae (i.e. as in *Gaucelmus*) in order to test the phylogenetic value of this character.

Pimoidae

This taxon, long considered part of the Linyphiidae, was recently raised to family status by Hormiga (1994a, b). The family comprises 21 species in one genus (*Pimoa*) occurring in temperate North America and Eurasia.

Pimoids are medium-sized, and like linyphiids are long-legged spiders with at least femoral spines, lateral striae on the chelicerae, patella-tibia autospasy, and generally hanging beneath sheet webs (Fig. 4A). Hormiga (1994b) defended their monophyly based upon four unambiguous synapomorphies from the peculiar male palpal morphology.

Hormiga (1994b, figs 38–41, 78–82, 113–116, 143–146, 281–284, 333–336, 427–430) reviewed the spinnerets in detail. Pimoids share with Linyphiidae ALS PI spigots with highly reduced bases, few to no PMS AC spigots, no PMS nubbins, and the basal PLS CY spigot on a greatly enlarged base. Males lack the araneoid triplet. The PLS AC spigots of pimoids are reduced to one or none; the groundplan

optimization is one PLS AC and no PMS AC (with regain of PMS AC in other, more derived *Pimoa!*).

Based on Hormiga's (1994b) phylogeny, we reconstruct the groundplan for the family and score those states in this matrix.

Symphytognathidae

Although this family name was formerly attributed to a great variety of small to minute, lungless araneoid spiders (e.g. Forster, 1958, 1959; Gertsch, 1960; Levi & Levi, 1962), Forster and Platnick (1977) restricted it to small monophyletic group characterized by chelicerae that are fused at least at the base (Figs 11D, 21A). Currently the Symphytognathidae comprise 5 genera with about 25 species (Platnick, 1989) that occur in the tropical and south temperate parts of the world. Symphytognathids are minute, and contain the world's smallest known spiders. So far as is known, they build two-dimensional orb webs (Fig. 3C; Forster & Platnick, 1977, fig. 1; Eberhard, 1981, 1987a; Coddington, 1986a, figs 12.23, 12.24).

The spinnerets of the Symphytognathidae have never before been described in detail. We present SEM micrographs of a female and male of *Patu digua* from Colombia (Figs 36A–D, 37A–D), and of an unidentified female (possibly also a *Patu*) from Queensland (Fig. 35A–D). For such minute spiders the spigot complement is remarkably complete and contradicts the supposition that small size always entails loss of structures. Like most derived araneoids, there is a single ALS MAP spigot plus nubbin with 7–9 PI spigots with highly reduced bases; the PMS has a large, anteromedian CY spigot (absent in males), one AC spigot, and a large posteromedian mAP spigot and one nubbin. The PLS triplet is retained in the male (Fig. 37D) and consists of one large FL and two AG spigots; the latter share a common base (Fig. 36D). Both sexes have three PLS AC spigots. The basal CY spigot is larger than the mesal, nearly separated from the spinning field by a deep fold, and is situated on an enlarged base (Figs 35D, 36D). The colulus is reduced to a small fleshy knob surmounted by two setae (Fig. 23A).

Our choice of exemplars for the Symphytognathidae was driven by expediency. These spiders are rarely encountered, are rare in collections, and behavioral observations are few. We therefore chose as exemplars specimens from Colombia and Australia that we observed, collected, and prepared ourselves.

Synotaxidae

This family, first proposed as a family level taxon by Simon (1895), was monographed by Forster *et al.* (1990). Synotaxidae comprise 12 genera with 63 species, and with the exception of the neotropical genus *Synotaxus* all are restricted to the cool-temperate latitudes of Chile, Australia, and New Zealand. Forster *et al.* (1990) suggested that potential synapomorphies were the small, basal, dorsally excavated paracymbium (Figs 17E, 18C–F), a retrolateral cymbial incision (Fig. 18C), dorsal macroseta (Figs 18C, 19C) on the male palp (though the segment varies, and some lack such setae altogether), and greatly elongated, spineless legs. These spiders are small in stature, with a truncate sternum; the palpal bulb has a complex distal process or processes (Fig. 19B,C). We consider this a complex conductor. The webs are poorly known, and variable. Many construct a sheet, which may be irregular or an inverted bowl (*Pahoroides*: Fig. 2E; *Meringa*, Forster *et al.*, 1990; *Mangua*, *Pahoroides*, and *Runga*, Griswold, pers. obs.; *Chileotaxus*, D. Silva and N. Platnick, pers. comm.);

the lattice-like web of *Synotaxus*, which resembles a chicken-wire (or chain-link) fence, is unique (Fig. 2D; Eberhard, 1977).

Forster *et al.* (1990) illustrated the female spinnerets of species from several genera: *Chileotaxus*, *Synotaxus*, *Tupua*, *Nomaua*, *Mangua*, and *Pahora*. Unfortunately, the lone specimen of *Synotaxus* was poorly preserved, rendering spigot interpretation difficult. We here present male and female SEM micrographs of *Chileotaxus sans* from Chile (Figs 40A–D, 41A–D), *Meringa otago* (Figs 44A–D, 45A–D) and *Pahora murihiku* (Figs. 42A–D, 43A–D) from New Zealand, and a Peruvian species of *Synotaxus* (Figs 38A–D, 39A–D). The eight (*Pahora*) to 28 (*Synotaxus*) ALS PI spigots have reduced bases. In *Synotaxus* the PMS has three AC spigots (Figs. 38C, 39C), and otherwise is typically araneoid. In *Chileotaxus sans* the PMS shows no CY spigot and only one AC spigot (Fig. 40C); the mAP spigot has two large nubbins in both sexes. The PMS spigots of *Pahora murihiku* and *Meringa otago* are greatly reduced: the former has only the mAP spigot and a single AC spigot (Fig. 42C); the latter (Fig. 44C) lacks spigots altogether! The female PLS of all four genera have the araneoid triplet, which is retained in the *Chileotaxus* male (Fig. 41D) but is reduced to three small (*Pahora murihiku*: Fig. 43D) or one large (*Synotaxus*: Fig. 39D) nubbin in other males. In *Synotaxus* the two AG spigots are enlarged (but lack the enlarged tip opening typical of theridiid-necticids) and the FL spigot is displaced anteriorly rather than situated between the aggregates (Fig. 38D). PLS AC spigot number varies (twelve in *Synotaxus* [Figs 38D, 39D], six in *Chileotaxus* [Figs. 40D, 41D], five in *Meringa* [Fig. 44D], three in *Pahora* [Figs. 42D, 43D]). The latter three genera have lost the basal PLS CY spigot. The CY spigot condition in *Synotaxus* is somewhat unclear, but one mesal (adjacent to the FL) and one basal spigot, both clearly larger than the AC spigots, are probably CY spigots (Fig. 38D). They are absent in the male (Fig. 39D).

We have chosen as exemplars the type genus *Synotaxus*, representatives of the subfamilies Pahorinae (*Pahora murihiku*) and Physogleninae (*Meringa otago*), and the unusual Chilean *Chileotaxus sans*. In each case the species chosen was represented by sufficient well-preserved material.

Tetragnathidae

The family Tetragnathidae includes some of the most common and intensively studied spider genera, ranging from the huge orb-web building *Nephila* to the minute *Glenognatha*. Several species have been the subjects of numerous biological studies (see summary in Hormiga, Eberhard & Coddington, 1995). Tetragnathidae were first treated as a family by Menge (1866–79), but since then taxonomic opinion on the separation of Araneidae and Tetragnathidae has varied widely. Most recently Levi (1980b) and Levi and Eickstedt (1989) recognized Tetragnathidae as a family distinct from Araneidae and containing the subfamilies Metinae, Nephilinae, and Tetragnathinae; the monophyly of this family was defended by Coddington (1990a). Fifty-one genera and more than 900 species are included in the family Tetragnathidae as currently delimited (Platnick, 1989).

The evolution and higher level phylogeny of Tetragnathidae has been studied in detail by Hormiga *et al.* (1995) on the basis of exemplars from 14 genera representing the three above-mentioned subfamilies. The principal synapomorphy for the family is what Coddington (1990a, character 1) termed the “metine palp conformation”, now coded more precisely as a palpus in which the often globular tegulum lacks a median apophysis, and on which the apical conductor and embolus wrap around

each other (Fig. 10A,C; Hormiga *et al.*, 1995, characters 30, 27, and 31, respectively). These authors found that Metinae (=Metidae of some authors) were seriously paraphyletic.

The spinning organs of Tetragnathidae are well known (Kovoor, 1986; Coddington, 1989; Platnick *et al.*, 1991; Hormiga *et al.*, 1995); they are moderately diverse but still typically araneoid. The ALS has several to more than 100 PI spigots, whose bases are short but not reduced to the degree found in symphytognathoids and sheet web weavers. In all tetragnathids except *Pachygnatha* (Platnick *et al.*, 1991, fig. 279) the PMS mAP spigot has at least one nubbin. The PMS aciniform brush is usually absent (PMS AC spigot number reduced). The huge *Nephila* and *Nephilengys* have fewer than ten, and *Leucauge*, *Tetragnatha*, and *Glenognatha* have three or fewer. Nevertheless, *Meta* has more than 15 PMS AC spigots, and *Azilia* more than 30, which thus qualify as PMS brushes. The PLS spigot complement is typical, although the triplet is absent in the webless adult *Pachygnatha*. In all tetragnathids the basal CY spigot is located outside the PLS AC spinning field (peripheral), a feature shared with other derived araneoids and *Zygiella* among the araneids. The basal CY spigot is similar to the mesal one or that on the PMS, but in *Glenognatha* and *Pachygnatha* it is obviously larger and longer (Hormiga *et al.*, 1995, fig. 25D), a feature shared with the linyphiid-pimoid clade (Hormiga, 1994a).

Our exemplars were chosen to test the monophyly of the Tetragnathidae. We chose members of each subfamily: *Nephila* and *Nephilengys* from the Nephilinae, *Tetragnatha* and *Glenognatha* from the Tetragnathinae, and *Meta* and *Leucauge* from the metine assemblage.

Theridiidae

This cosmopolitan family is one of the largest, with over 2000 species in 55 genera (Platnick, 1989). The last comprehensive treatment of the family was Levi and Levi (1962), in which familial relimitation and generic synonymy reduced the number of genera from 140 to fewer than 50. In this work genera were diagnosed, and a sketch of theridiid classification was presented. Recently, Forster *et al.* (1990) presented a brief discussion of theridiid interrelationships, separating out *Synotaxus* as the basonym of the Synotaxidae, and arguing for an enlarged Hadrotarsidae as a theridiid subfamily.

Theridiids range from minute to large, and typically construct a 'gumfoot' web (Fig. 2A–C) consisting of an irregular retreat suspended beneath a covering object, with few to several sticky lines affixed under higher tension between the retreat and lower substrate (there are many exceptions to this rule). Nesticids and theridiids can subdue prey by flinging large globs of sticky silk (Fig. 6) with the comb on the fourth tarsus (Fig. 22H). PLS aggregate spigots are modified to enable this behavioral synapomorphy (Coddington, 1989). Some are of medical importance (*Latrodectus*, the 'widow spiders').

The spinning organs of Theridiidae are moderately known. Coddington illustrated *Latrodectus variolus* and *Theridula opulenta* (Coddington, 1989, figs 26–29 and 30–33, respectively); Forster *et al.* illustrated *Dipoena beni*, *Euryopsis funebris*, *Enoplognatha ovata*, *Argyrodes trigona*, *Steatoda borealis*, *Anelosimus eximius*, and *Achaearanea tepidariorum* (Forster *et al.*, 1990, figs 343–346, 347–350, 351–354, 355–358, 359–362, 363–366, and 367–370, respectively). The ALS has about 12 (*Argyrodes*) to more than 40 (*Latrodectus*) PI spigots with highly reduced bases. The PMS usually has one to few AC spigots

and a posterior mAP spigot, but in *Euryopsis* and *Hadrotarsus* only the mAP spigot remains. Even the kleptoparasitic *Argyrodes* species have the araneoid triplet. The AG spigots are very large and laterally compressed with large tip openings; this morphology enables the sticky silk attack. The PLS has several AC spigots, and two CY spigots of about equal size located close to the AC spinning field. The colulus varies from a triangular, fleshy lobe to a minute vestige surmounted by two setae.

In their review, Levi and Levi (1962) emphasized the phylogenetic importance of colulus form. The current choice of exemplars attempts to incorporate this variation, including species with large (*Steatoda*) and reduced (*Anelosimus*, the hadrotarsines) coluli. To examine the placement of the subfamily Hadrotarsinae, we include a hadrotarsine doublet of *Euryopsis* and *Dipoena*.

Theridiosomatidae

This cosmopolitan family of nearly seventy species in 12 genera is concentrated in the tropics. Coddington (1986c) provided a review of the genera of the family and a cladogram for the genera, and offered extensive details on web architecture. These are small to minute spiders with short to medium length legs; the male palpal bulb is large. Synapomorphies for the family proposed by Coddington (1986c) are a pair of pits on the anterior margin of the sternum near the labial base, connate spermathecae, and an elongate dorsal trichobothrium on tibia IV. All except members of the genus *Chthonos* build orb webs (Figs 1D, 4C), though some are so highly modified (e.g. the web of *Wendilgarda*) as to be hardly recognizable as such.

The female spinning organs of *Theridiosoma gemmosum* were described by Coddington (1986c, figs 6–9) but the still rudimentary knowledge of gland-spigot correspondences at the time caused some mislabelling of spigots. Here we present SEM micrographs of a male and female of *Epeirotypus chavarría* (Figs 24A–D, 25A–D). The ALS has 20–30 PI spigots with reduced bases and a sharp, conspicuously upturned rim (Fig. 24B). The PMS has three to four AC spigots (Figs 24C, 25C; labels AM and CY reversed in Coddington, 1986c, fig. 8). The PLS AG spigots are set off from the FL spigot in a pit (Figs. 24D, 25D; labels CY and AG reversed in Coddington, 1986c, fig. 9). The triplet often persists in males. The PLS have 7–12 AC spigots, and the PLS CY spigots are peripheral.

For exemplars we have chosen well-known species from each side of the basal dichotomy in Coddington's (1986c, fig. 1) cladogram: *Theridiosoma gemmosum*, representing the type genus of the family, and *Epeirotypus chavarría*.

CHARACTERS FOR PHYLOGENETIC ANALYSIS OF ORBICULARIAE

For efficiency we jointly discuss character concepts and the evolution of specific characters in Appendix 1: we list and define all characters and their states and discuss the optimization of each character on the preferred cladogram (Figs 7–9). The distribution of character states across exemplar taxa, the length and consistency and retention indices of each character on the preferred cladogram, weights assigned to them under successive weighting by Hennig86, and character numbers assigned when previously used in quantitative cladistic studies of Orbiculariae, are listed in Appendix 2.

Character polarities

Character polarities within Araneoidea are determined with reference to Deinopoidea as outgroup. In most cases polarity within Araneoidea or Deinopoidea is unambiguous, but in several cases ambiguous optimizations at the base of this cladogram made it necessary to look beyond the Orbiculariae. The question of the sister-group of Orbiculariae has not been satisfactorily answered. Coddington (1990b) implied Dictynoidea (*sensu* Forster, 1970) as a possible orbicularian outgroup; Platnick *et al.* (1991) suggested that the Amaurobioidea (*sensu* Forster, 1970; represented in their study by exemplar *Amaurobius*) and Dictynoidea (represented by exemplar *Dictyna*) together were the orbicularian outgroup. Coddington and Levi (1991) suggested that their new, informal taxon, the ‘RTA clade’ (including Dictynoida, Amaurobioidea, Dionycha, and Lycosoidea) was the orbicularian outgroup. This outgroup hypothesis differs from that of Platnick *et al.* (1991) only in its breadth (adding Dionycha and Lycosoidea to the Dictynoidea and Amaurobioidea), and is the best-supported currently available.

Some evidence also supports Nicodamidae (especially the cribellate *Megadictyna*) as the sister group of Orbiculariae. Work in progress by the authors on araneomorph higher classification found orbicularian or araneoid features in *Megadictyna* such as serrate ‘false claw’ tarsal setae (Fig. 22A,B), a posterior PMS mAP spigot, and wrap attack behavior (CG, pers. obs.). However, the former study is still in a preliminary stage and several equally good alternative placements of *Megadictyna* exist. It seems reasonable to wait until that result is stable before considering the effect of Nicodamidae as the sister group to Orbiculariae. For most character systems, the sister group of Orbiculariae will have little or no effect on polarities within Araneoidea.

RESULTS: PHYLOGENY OF ORBICULARIAE

Whereas we have previously presented these results in outline form (Griswold *et al.*, 1994), Figures 7–9 detail for the first time a quantitatively derived, fully resolved phylogeny of orbicularian families. We discuss all clades and their synapomorphies in turn. Both unambiguous and ambiguous (i.e. having alternative optimizations) synapomorphies are discussed regardless of homoplasy. Numbers in parentheses refer to character numbers in Appendix 2; see Appendix 1 for a full discussion of character state evolution and optimization. Four newly detected clades seem significant enough to warrant at least informal names: the ‘reduced piriform clade’ (clade 20: symphytognathoids and araneoid sheet web weavers), the ‘araneoid sheet web weavers’ (clade 12: linyphioids, theridioids, and cyatholipoids), the ‘spineless femur clade’ (clade 10: the theridioids plus cyatholipoids) and the cyatholipoids (clade 5: Cyatholipidae and Synotaxidae).

Clade 29, Deinopoidea, including the families Deinopidae and Uloboridae. Unambiguous synapomorphies include the loss of the PME tapetum (28), presence of abdominal tubercles (46), a ventral row of short, erect macrosetae on tarsus IV (62), numerous CY spigots on the PMS (73) and PLS (74), and a web posture in which legs I and II are held extended (81).

Clade 28, Araneoidea. Unambiguous synapomorphies include the paracymbium (7), juxtaposed lateral eyes (30), a labium that is wider than long (41), serrate setae (51),

loss of the cribellum (66), appearance of a mAP spigot nubbin on the PMS (71), movement of the PMS mAP spigot to a posterior position (72), appearance of FL (77) and AG (78) spigots on the PLS, squamate cuticle (79), and hub bite-out behaviour (89). Another possible synapomorphy is the high clypeus (31).

Clade 27, Araneidae. Represented in these data by the exemplar genera *Metepeira* and *Argiope*, unambiguous synapomorphies include the mesal cymbium (2), radix in the embolic division of the male palp (20), PME tapetum much displaced towards the sagittal plane (29), and the sustentaculum on tarsus IV (64). Another possible synapomorphy is the embolus-tegulum membrane (22).

Clade 26, the derived araneoids. This group of families is characterized by loss of the PMS aciniform brush (70), the peripheral position of the mesal PLS CY spigot (76), and the use of the inner leg I tap (87) to determine the next point of attachment of the sticky spiral. Many derived araneoids, of course, no longer spin orbs and so the last character does not apply, and nephilines use a tap of OL4. This clade was implied by Coddington (1990b), based upon a smaller range of exemplar taxa, and is fully justified here.

Clade 25, Tetragnathidae. Figure 8 supports the monophyly of this family including the tetragnathines, metines, and nephilines. Unambiguous synapomorphies for the Tetragnathidae include the terminal conductor (17) that spirals with the embolus (19). An embolus-tegulum membrane (22) and loss of the MA (16) are other possible synapomorphies.

Clade 24. This group of tetragnathids, including *Meta* and the tetragnathines, is supported by the ‘metine resting posture’ in which the spiders hang with legs I and II outstretched and held together (81) and an open hub (90).

Clade 23, Leucauge is united with the true tetragnathines at this node by ventral caeca that extend into the chelicerae and pedipalpal coxae and a posterior, unpaired dorsal caecum (44), and appearance of femur IV trichobothria (58). Another possible synapomorphy is smooth booklung covers (49)

Clade 22, Tetragnathinae. The true tetragnathines share a large suite of apomorphies: a cymbium that is medially constricted (4) and an elongate (9), flexibly attached paracymbium (8), enlarged reservoir diameter (13), haplogyne female genitalia (24), loss of the PME tapeta (28) and enlarged male chelicerae (33).

Clade 21, Nephilinae. Figure 8 suggests that this group, sometimes accorded family status, is sister to the remaining Tetragnathidae. Our exemplars are the higher nephilines *Nephila* and *Nephilengys*. The long list of unambiguous synapomorphies supporting the higher nephilines include a squat paracymbium (9), an embolus oriented at 90 degrees to the tegulum (23), female gigantism (32), striae on the cheliceral boss (39), a dorsal scutum on the male abdomen (47), radius construction in which two radii are laid in a single pass from hub to frame and back (83, ‘nephiline’), persistence of the temporary, non-sticky spiral (86), the use of a tap of the outer leg IV to determine the next point of attachment of the sticky spiral (87), and loss of both hub bite-out (89) and wrap-bite attack (92).

Clade 20, the reduced piriform clade. This newly proposed group includes several large families containing spiders of small stature. Unambiguous synapomorphies include

smooth booklung covers (49) and having the bases of the PI spigots reduced or absent so that the shaft appears to arise directly from the spinneret (69).

Clade 19, the symphytognathoid families. This group contains four families of small to minute spiders, most of which make elaborate, highly modified orb webs. Unambiguous synapomorphies include a posteriorly truncate sternum (43, reversed in *Maymena*), loss of the claw on the female palp (53), greatly elongate fourth tarsal median claw (63, reversed in the Anapidae), and double attachment of the eggsac near the hub (91). Other possible synapomorphies include loss of the wrap bite attack (92), construction of three-dimensional orb webs (82) with anastomosed radii (84) and addition of hub loops after sticky spiral construction is complete (88). Technically, these last three characters may optimize as synapomorphies for clade 20 with loss of these orb-weaving peculiarities in clade 12, but as no member of clade 12 still makes an orb this optimization is untestable. Therefore, we prefer to consider orb web characters 82, 84, and 88 as symphytognathoid synapomorphies.

Clade 18. The monophyly of Mysmenidae, Anapidae, and Symphytognathidae is supported by loss of the paracymbium (7), loss of the conductor (14, with subsequent evolution of a potentially analogous structure in some anapids), loss of the median apophysis (16), and, after completion of sticky spiral construction, the addition of accessory radii not specifically attached to the sticky spiral (85).

Clade 17. The families Anapidae and Symphytognathidae are united by reduction or loss of the AME (27), origin of cheliceral teeth from a mound or common base (36), reduction or loss of the female palp (52), loss of spines from femora (59), and enlargement of the base of the basal PLS CY spigot (75). Modification of the anterior book lungs into tracheae (48) is a potential synapomorphy here, with parallel modifications in some mysmenids.

Clade 16, Symphytognathidae. Unambiguous synapomorphies are cheliceral fusion along the midline (38) and a colulus reduced until smaller than the setae arising from it (65).

Clade 15, Anapidae. Unambiguous synapomorphies are the haplogyne female genitalia (24), labral spur (40), dorsal scutum on at least the male abdomen (47) and reduction of the elongate fourth tarsal median claw to normal (63, reversal).

Clade 14, Mysmenidae. Unambiguous synapomorphies include the distally twisted and notched cymbium (3), the small, sclerotized spot located subapically on the venter of femora I and II (56) and the male metatarsus I clasping spine (57).

Clade 13, Theridiosomatidae. Unambiguous synapomorphies include connate spermathecae (25), sternal pits (42) and a greatly elongate dorsal trichobothrium on the fourth tibiae (61).

Clade 12, the araneoid sheet web weavers. This newly proposed clade includes all family level araneoid taxa that no longer build orb webs. Unambiguous synapomorphies include the modification of the orb web into a sheet (80) and loss of the PMS mAP spigot nubbin (71).

Clade 11, the linyphioid families. This large clade includes those taxa formerly placed in Linyphiidae. Hormiga (1994a) erected a separate family for *Pimoa*. Unambiguous

synapomorphies include stridulating striae ectally on the male chelicerae (37), patella-tibia autospasy (60), and an enlarged base on the basal PLS CY spigot (75). Loss of wrap-bite attack (92) is a potential synapomorphy.

Clade 10, the 'spineless femur clade'. The Synotaxidae were previously associated with the theridiid-necticid lineage; cyatholipids are here newly placed in this group. Loss of spines from leg femora is a synapomorphy (59). The origin of theridiid sticky-silk wrap attack behavior (93) also optimizes here: its presence in cyatholipids and synotaxids other than *Synotaxus* is unconfirmed (see discussion of character 93 below).

Clade 9, the theridioids. Synapomorphies include appearance of the 'theridiid tegular apophysis' (Coddington, 1990a) in addition to the conductor and median apophysis (18). Other synapomorphies include a comb of curved, serrated macrosetae beneath tarsus IV (62), huge AG spigots on the PLS (78), and construction of the 'gumfoot' web (80).

Clade 8, Theridiidae. This family is characterized by loss of the paracymbium (7) and appearance of a hook near the distal margin of the alveolus (11), affecting a unique locking mechanism between the bulb and cymbium in the unexpanded bulb (12).

Clade 7. Within the Theridiidae *Anelosimus* and the hadrotarsines are united by the reduction of the fleshy colulus until it is much shorter than the two setae arising from it (65).

Clade 6, Hadrotarsinae. The monophyly of Hadrotarsinae (Forster *et al.*, 1990) is supported by two pairs of spermathecae (26), chelicerae with elongate fangs (34) and shortened paturon (35), a posteriorly truncate sternum (43), a unique, palmate female palpal claw (54) and a stridulating structure formed by a series of parallel ridges on the median surfaces of the ALS (67).

Clade 5, cyatholipoids. These results place Cyatholipidae and Synotaxidae as sister groups. Synapomorphies supporting this hypothesis include a cup-shaped paracymbium (9, state 3), loss of the median apophysis (16), and truncate posterior sternal margin (43). Another possible synapomorphy is the loss of the basal CY spigot from the PLS (74). If optimized in this way, regain of this spigot is required in *Synotaxus*.

Clade 4, Cyatholipidae. The monophyly of this peculiar group of spiders has never been in doubt, though its placement has long been problematical. Unambiguous synapomorphies for this family are a cymbium greatly expanded retrolaterally (5) with a retromedian process (10), a broad posterior tracheal spiracle (50) and loss of the claw from the female palp (53). Loss of the basal CY spigot from the PLS (74) is a possible synapomorphy: if optimized here parallel loss is required at node 2. See discussion of this character for node 5 above.

Clade 3, Synotaxidae. The Synotaxidae were proposed as a family by Forster *et al.* (1990), and these data support their monophyly. Synapomorphies are a retromarginal groove on the cymbium (6, ambiguous in *Pahora*), and a complex conductor (15), terminally situated (17).

Clade 2. Within the Synotaxidae *Chileotaxus*, *Meringa*, and *Pahora* are united by basally thickened femora (55) and loss of cylindrical spigots from the PMS (73). Loss of the basal CY spigot from the PLS (74) is a possible synapomorphy: if optimized here

parallel loss is required for the cyatholipids. See discussion of this character for node 5 above.

Clade 1. The synotaxid subfamilies Pahorinae (represented by *Pahora*) and Physogleninae (represented by *Meringa*) are united by stridulation involving a file on the abdomen (45).

DISCUSSION

These results clarify existing interpretations of three important character systems in orbicularian spiders: spinning organs, male genitalia, and web architecture and building behaviour.

The evolution of the spinning field in this impressively diverse lineage of spiders apparently proceeded mainly through reduction and simplification of fields containing multiple spigots of the same gland type. Potential outgroups to orbicularians as well as all deinopoid and araneid taxa (lineages basal to derived araneoids) have spigot-rich spinning fields on all spinnerets (Fig. 48). The ALS has large numbers of piriform spigots, while the PMS and PLS have many aciniform spigots. Relatively more derived orbicularians (e.g. Theridiosomatidae, Cyatholipidae or Theridiidae, Figs 24–47) have many fewer spigots. For the piriform field, this reduction means that derived araneoids cement draglines to substrate and make intra-web junctions with fewer piriform spigots than their more plesiomorphic outgroups. Derived araneoids are, on the whole, smaller than their outgroups (Levi, 1980a; Craig, 1987a) (many exceptions occur) and it may be that these smaller, lighter spiders require fewer piriform spigots to achieve the same proportional strength of the attachment point. (Craig 1987a, b) reported that the webs of small orb weavers are low-energy-absorbing, suggesting that strength of piriform attachment may not be as important as in larger spiders. Alternatively, the piriform product of derived araneoids may be more effective, so that fewer spigots (and glands) suffice. Coincident with this reduction in piriform number is the reduction of piriform spigot bases. In derived araneoids piriform bases have all but disappeared so that spigot shafts emerge directly from the surface of the spinneret (Figs 24B, 27B, 40B). This reduction probably reflects the increasing integration of piriform spigots into one specialized spigot battery for silk-substrate and silk-silk junctions.

The trend to reduction of spigot number is also evident in aciniform fields. Derived araneoids such as anapids, theridiids, cyatholipids, or synotaxids have substantially fewer aciniform spigots than their outgroups. Therefore these spiders have lost the ability to spin as many aciniform lines simultaneously. In less derived araneoids, multiple aciniform lines have primarily two uses: prey immobilization and/or wrapping, and web decoration (possibly in cocoons as well). There are no web decorations in derived araneoids (Craig, 1994; Craig & Bernard, 1990) and it appears that animals equipped with so few spigots would have difficulty making an obvious visual display with aciniform silk.

These results also fail to refute homology of the wrap-attack between deinopids and araneids. These attacks require the ability to spin massive amounts and numbers of aciniform lines in order to overwhelm and immobilize the prey before delivering the paralyzing bite. In uloborids the reliance on the wrap-attack is nearly complete; all members of the family examined appear to lack venom glands (Opell, *in lit.*).

Uloborids are therefore committed to maintaining numerous aciniform spigots. Araneids, on the other hand, vary widely in their use of aciniform silk either to immobilize or to wrap prey. Most taxa observed to date do one or both; in either case many aciniform lines are used.

Derived araneoids have less need for aciniform silk. Prey are only slightly wrapped after being subdued through envenomation, and prey transport can be accomplished using ampullate gland silk. Aciniform silk may be used in the eggsac, but eggsac construction from the point of view of silks has not been studied.

Finally, the morphology, number, and position of unique spigots is relatively constant and characteristic throughout orbicularians. Major and minor ampullates, flagelliforms (or pseudoflagelliforms), aggregates, and cylindricals are consistently present.

The second major result concerns the difficulty of using male palpal morphology at the superfamily level in this study. Considering the complexity of orbicularian genitalia, few suprafamilial homologies can be established. Both linyphiids and araneids have complex embolic divisions in which a number of sclerites in addition to the embolus originate on a sclerite that attaches to the tegulum via a membrane. Despite these similarities, it now appears that these complex embolic divisions are not homologous. Coddington (1990a) established that the median apophysis and the conductor showed substantial homoplasy in a more restricted selection of families than are treated here. The new lineages considered here (pinoids, hadrotarsine theridiids, synotaxids and cyatholipids) add more homoplasy in these characters. The paracymbium is another example. A basal, sclerotized structure on the cymbium (7) is still present in 8 of the 12 families, but as to its form (9), few informative homology statements can be established. Hormiga (1993) discussed the problem, and the taxa added here only add to its complexity. We conclude that palpal homologies across families are difficult to code consistently and usually display high levels of homoplasy, if they can be detected at all.

The third result concerns web evolution. These results depict a simple and increasingly coherent picture of several important aspects of araneoid evolution. Several groupings previously suggested are corroborated. The monophyly of the symphytognathoids (Theridiosomatidae, Mysmenidae, Anapidae, and Symphytognathidae), deinopoids and the close association of Nesticidae and Theridiidae are underscored. Tetragnathid monophyly is confirmed, and the tetragnathid topology mirrors that of Hormiga *et al.* (1995) even though this study includes a more exhaustive sample of outgroups.

Several new discoveries emerge. The theridiid–nesticid lineage is placed unambiguously as the sister group of the cyatholipoids, which together are the sister group of the linyphioids. The previous comprehensive, quantitative study of Araneoidea (Coddington, 1990a) could do no better than to place them with equal parsimony at five places (as sister to tetragnathids, tetragnathids–symphytognathoids, linyphiids–araneids, symphytognathoids, or as plesiomorphic sister group to other araneoids). The current placement was not suggested by those possibilities. New data that implied placement of the linyphiids among the derived Araneoidea near theridiids and far from the araneids (e.g. characters 69, 70, 76), tipped the balance. Association of the theridiid–nesticid lineage with Synotaxidae was suggested by Forster *et al.* (1990) based upon the presence in *Synotaxus* of the behavior theridiid sticky silk attack wrap (character 93, this study, corroborated) and the presumed presence of a theridiid tegular apophysis (character 18, this study, refuted). The

synonymy of Hadrotarsidae with Theridiidae (Forster *et al.*, 1990) is confirmed: hadrotarsines nest deep within the theridiids, a placement suggested intuitively by their modified chelicerae, reduced spinning organs, and specialized lifestyle. The linyphiids are placed as a derived araneoid lineage, far from Araneidae, in spite of similarities in palp conformation. This underscores the possibility that complex embolic divisions probably have evolved independently in araneids and linyphiids: the linyphiid column is not homologous to the araneid distal haematodocha nor the linyphiid 'radix' to the araneid radix (Hornig, 1994a: 56–57). Nephilines are confirmed as sister to the remaining tetragnathids; if the cladistic structure of either lineage becomes complex enough to require additional taxonomic ranks, nephilines could be raised to family rank, hence 'Nephilidae'. Finally, the cyatholipid/linyphiid relationship suggested by Coddington (1990a) and Coddington and Levi (1991) is refuted. Cyatholipids are related to synotaxids, and their similarity in sheet web architecture to linyphiids is a plesiomorphy (shared as well with many synotaxids).

It is possible to sketch the araneoid groundplan and provide a rough outline of trends in araneoid evolution. The hypothetical primitive araneoid would probably have been a medium-sized to large, 2-lunged, ecribellate spider living in a simple, planar, complete orb (Fig. 1C) and perhaps subduing aerial prey with a wrap attack involving a swath of aciniform gland silk. This spider was 8-eyed with median canoe tapeta in all indirect eyes, had large chelicerae with teeth on the fang furrow, a posteriorly attenuate sternum, spiny legs, and a well-developed female palp with claw. The female genitalia had separate copulatory and fertilization ducts; the male palp had a simple, oval cymbium with a firmly-attached, basal paracymbial hook, and a tegulum with conductor, median apophysis and simple embolus. The ALS had a single lateral MAP spigot accompanied by a nubbin and a field of numerous PI spigots with large bases; the PMS had a posterior mAP spigot accompanied by a nubbin and a single, anterior to median CY spigot; the PLS had a triplet of two AG and one FL spigots for producing sticky silk line and two CY spigots; both the PMS and PLS had numerous AC spigots. Evolutionary trends include a reduction in overall size (derived araneoids), loss of tegular sclerites (but with increased complexity of the embolic division arising in parallel in araneids and some linyphiids), reduction in leg spines (especially in theridioids), and modifications in spigot morphology related to changes in prey capture behavior (e.g. reduction in AC spigot number related to the substitution of bite for wrap attack; enlarged AG spigots for sticky silk wrap attack). Trends in web evolution seem to be toward prey specialization (e.g. the ladder web of *Scoloderus* for moth capture, tensed webs of most theridiosomatids, reduced webs and ultrasticky silk associated with moth pheromone mimicry in mastophorine araneids) or toward filling enclosed spaces with more or less permanent, defensive webs, and capturing terrestrial or otherwise ambulatory prey (i.e. the coincident trends toward three-dimensionality in symphytognathoid orbs [Fig. 3A,B,D] and space-filling sheet and gumfoot webs, in the linyphioids [Fig. 4B] and theridioids [Fig. 2A–C, E]).

Perhaps the most exciting result of this study is a simple and coherent picture of web evolution in the Orbiculariae. Elaborate and unparsimonious schemes abound in the literature, even to the present day. Kullmann (1972), quoted in what is currently the most popular introduction to spiders (Foelix, 1982), hypothesized at least two origins of the orb. Heimer and Nentwig (1982) suggested no fewer than seven independent origins of the orb. Shear (1994), in the most recent popular discussion of web evolution, admits the possibility of orb web monophyly (among

other scenarios) but postulates independent origins of linyphiid sheet and theridiid gumfoot webs from orbs. The picture suggested by this study is much simpler: the orb web is monophyletic, the araneoid sheet web is monophyletic and derived from an orb, and the ‘gum foot’ web of theridiid-necticid lineage is monophyletic and derived from a sheet.

How and why did the orb evolve into a sheet? One possibility is a change in function from trapping airborne prey to capturing ambulatory prey, or at least prey arriving from below. Sheet webs are widely considered to be knock down webs for airborne prey, but this generalization, at least for araneoids, is untested by observations across a wide range of taxa. Sheets probably catch prey in several ways. In particular, a sheet web builder spinning an inconspicuous web between prey refugia (e.g. leaf litter, a dark hollow, at the edge of a log) and the bright sky could intercept many daytime flying prey that orient via celestial cues. Many linyphiid sheets are concave up (domed) rather than down (bowl), despite the fact that the dome form is more difficult to achieve than bowl form in a tensed net, and this fact requires explanation (hold a simple sheet horizontal and it is concave up, not down). Domed webs (Fig. 2E) may be more like malaise traps than beating trays, i.e. directed at prey arriving from below, not above. The first evolutionary step in araneoid modification of the orb web may have been a shift in trapping function (from catching prey flying from above to catching prey walking, jumping, or flying from below), followed by a loss in radial symmetry to form an irregular sheet better able to fill available horizontal space, finally involving a transfer of sticky lines from the sheet directly to the substrate below to completely fill an enclosed space. The transfer of attachment of the distal ends of sticky lines from silk to the substrate (as in gumfoot webs) may be presaged by the fact that sticky (SS) lines in sheet webs may not be attached to each non-sticky (NS) line that they cross (contra most orbs) but may skip few to many crossings before they attach again. The transition from attachment of such SS lines to other silk lines to attaching them to substrate may be simple. This hypothetical web transition parallels (and was perhaps driven by) a change from life in relatively exposed and open web sites (i.e. relatively far from vegetation such as araneids and tetragnathids prefer) to partially enclosed and protected web sites that are always relatively closer to vegetation, hard surfaces, and multiple anchor points for guy lines. Many linyphiids and cyatholipids prefer crowded, low vegetation such as ferns and grass stems, and theridiids often prefer even more fully enclosed web sites such as beneath logs and stones, in animal burrows, etc. Alternatively, size changes may have influenced web form. Craig (1987a, b) has suggested that evolution of small size was crucial to the derivation of modified web architectures in araneoids. She demonstrated that small webs are low-energy-absorbing, and argued that ‘escape’ from the structural constraints of large, high-energy-absorbing webs (which are necessarily planar orbs) allowed web modification, occupation of new microhabitats, and exploitation of new prey.

Predation on orb weavers could also have driven the change. Once diurnal flying predators evolved the agility to pick orb weavers from the hub, re-evolution of a more protective web architecture may have made sense. There are very few fossil orb weavers known, but even so the extant specimens are very old, and may predate the evolution of agile flyers among predacious insects and parasitoids—certainly they seem to predate insectivorous birds. Complex three-dimensional architectures require a correspondingly complex series of many anchor points dispersed in all dimensions. Web sites offering these features are more common in protected and

enclosed spaces. In fact, it is difficult to envisage the typical theridiid or linyphiid architecture isolated in space, suspended 50 cm or more from substrate in all directions. Yet orb weavers prefer the latter situations. Whatever the driving force, the trend in araneoids is clearly toward small size and modified web architectures.

The orb web has often been called the pinnacle of web evolution, a masterpiece of optimality so adaptive that convergence upon this form was not only likely but logical. Do the figures on orbicularian diversity bear out this picture of the orb as a key to success? A rough correlation of species diversity by web type may be taken from the figures in Platnick (1989) on the assumption that described diversity roughly reflects total diversity. He records about 10 200 species for the Orbiculariae. If one generalizes web type by family (ignoring derived exceptions, e.g. loss of orb webs in *Pachygnatha* and mastophorine araneids, the unique web of *Synotaxus*), approximately 40% of orbicularians still build orb webs (deinopoids, araneids, tetragnathids, and symphytognathoids). Of those that still build orbs, nearly 8% (3% of total Orbiculariae) build orbs highly modified from the plesiomorphic planar, radially symmetric design (deinopids, theridiosomatids, mysmenids, and anapids). Approximately 37% of orbicularian species build sheet webs (linyphiids, pimoids, synotaxids, and cyatholipids), and nearly 23% build gumfoot webs (nesticids and theridiids). In other words, 60% of orbicularian species no longer build orbs! It is undeniable that the orb architecture works: the more than 4000 species that build orbs comprise nearly 12% of the 34 000 described species of spiders (Platnick, 1989). Nevertheless, for most orbicularians, the orb web has been an evolutionary base camp rather than a summit.

ACKNOWLEDGEMENTS

Major financial support for this project came from National Science Foundation grants BSR-9020439 and DEB-9020439 to CG. Additional support for CG came from the Exline-Frizzell and In-house Research Funds of the CAS. Partial support for GH came from the Maryland Center for Systematic Entomology program of the University of Maryland and SI and from a Gahan Fellowship at the Department of Entomology, University of Maryland. The Danish Natural Science Research Council (grants 11-7440, 11-8038, 11-9877 and 11-0090), a Fulbright Research Fellowship, and SI provided major support for NS. Grants from the SI Scholarly Studies Program facilitated fieldwork in Cameroon by GH and JC, and in Madagascar by JC and NS. A grant from the Neotropical Lowlands Research Program helped with data analysis. Fieldwork in Cameroon by NS was supported by the National Geographic Society; that in Madagascar was partially supported by the Danish Crown Prince Frederik Fund. Fieldwork in Australia by GH and JC was supported by Research Opportunities Grants from SI.

Specimens and observations essential to the completion of this study were obtained through fieldwork in Australia, Cameroon, Madagascar, and New Zealand. Permits to do research in Cameroon were made available from the Institute of Zootechnical Research, Ministry of Higher Education and Scientific Research of the Republic of Cameroon. We especially thank Dr John T. Banser, Director of the Institute, and Dr Chris Wanzie, for facilitating our research in Cameroon. Fieldwork in Cameroon was also made possible by the permission and assistance from the following traditional

authorities: Their Royal Highnesses the chiefs of Batoke, Etome, and Mapanja, H.R.H. R. M. Ntoko, Paramount Chief of the Bakossi, Chiefs Jonas Achang, Albert Ekinde, and Peter Epie of Nyassosso, and H.R.H. the Fon of Oku. Permits to do research in Australia were made available from the Queensland National Parks and Wildlife Service, facilitated by Dr R. Raven of the Queensland Museum. Permits to do research in and export specimens from Madagascar were obtained from the Association Nationale pour le Gestion des Aires Protégées (ANGAP) and Direction des Eaux et Forêts of the Ministre d'Etat a L'Agriculture et au Developpement Rural, under the Accord de Collaboration of the Xerces Society, facilitated by Dr C. Kremen, Mr C. Ramilison, and Ms B. Davies of that organization. A permit to collect specimens in New Zealand protected areas was obtained from Te Papa Atawhai (Department of Conservation).

Warmest thanks are extended from CG to Drs Ray and Lyn Forster for hospitality in New Zealand, from JC, CG, and GH to Drs Robert Raven and Val Davies for hospitality in Australia, from JC, CG, and NS to Mr Rija Andriamasamana for his invaluable assistance and research collaboration in Madagascar, and from all of us to Chris Wanzie for hospitality in Cameroon. Major assistance with organization and logistics was provided by Mr Ndam Nouhou, Conservator, and Mr Mark Bovey, Limbe Botanical Gardens, and Mr Joe Watts, T. C. O. Forester (Mt. Cameroon); Mr Simon Tame, International Council for Bird Preservation (ICBP), Mount Kilum Project (Mt. Oku, Cameroon), and Chris and Elizabeth Bowden, ICBP, (Mt. Kupe, Cameroon). Essential assistance in the field was provided by Mr Jonas Aka and Peter Masongo (Cameroon) and Mr Roland Christophe (Madagascar).

Ray Forster, Dr Herbert W. Levi, Ms Diana Silva, and Mr Darrell Ubick kindly provided specimens essential to the completion of this project. We thank Dr William Peck for arranging to have the Exline-Peck arachnid collection, which provided much of the research material pertinent to this study, deposited at CAS.

Assistance with Scanning Electron Microscope examination was provided by D. Ubick (CAS) and Mrs Susan Breydon at SI; Mr Dong Lin (CAS) and Mr Gert Brovad (ZMUC) provided photographic service. Darrell Ubick and Johanna Brandrift (CAS) and Scott Larcher (SI) assisted in ways too numerous to mention. Photos of webs and living animals were taken by Chip Clark (CC), Jonathan Coddington (JC), Gustavo Hormiga (GH), and Teresa Meikle (TM).

A draft of the manuscript was critically read by Drs Catherine Craig, H. W. Levi, Brent Opell and Norman I. Platnick.

REFERENCES

- Bhatnagar RDS, Rempel JG. 1962.** The structure, function, and postembryonic development of the male and female copulatory organs of the Black Widow Spider *Latrodectus curacaviensis* (Müller). *Canadian Journal of Zoology* **40**: 465–510.
- Baum S. 1972.** Zum “Cribellaten-Problem”: Die Genitalstrukturen der Oecobiinae und Urocteinae (Arachnida: Araneidae: Oecobiidae). *Abhandlungen und Verhandlungen des Naturwissenschaftlichen Vereins in Hamburg, (NF)* **16**: 101–153.
- Carico JE. 1978.** Predator behavior in *Euryopis funebris* (Hentz) (Araneae: Theridiidae) and the evolutionary significance of web reduction. *Symposium of the Zoological Society of London* **42**: 51–58.
- Carpenter JM. 1988.** Choosing among multiple equally parsimonious cladograms. *Cladistics* **4**: 291–296.
- Coddington JA. 1983.** A temporary slide mount allowing precise manipulation of small structures. *Abhandlungen und Verhandlungen des Naturwissenschaftlichen Vereins in Hamburg, (NF)* **26**: 291–292.
- Coddington JA. 1986a.** The monophyletic origin of the orb web. In: Shear WA, ed. *Spiders: Webs, behavior, and evolution*. California: Stanford University Press, 319–363.
- Coddington JA. 1986b.** Orb webs in ‘non-orb weaving’ ogre faced spiders (Araneae: Deinopidae): a question of genealogy. *Cladistics* **2**: 53–67.
- Coddington JA. 1986c.** The genera of the spider family Theridiosomatidae. *Smithsonian Contributions to Zoology* **422**: 1–96.
- Coddington JA. 1989.** Spinneret silk spigot morphology: Evidence for the monophyly of orbweaving spiders, Cyrtophorinae (Araneidae), and the group Theridiidae plus Nesticiidae. *Journal of Arachnology* **17**: 71–95.
- Coddington JA. 1990a.** Ontogeny and homology in the male palpus of orb-weaving spiders and their relatives, with comments on phylogeny (Araneoclauda: Araneoidea, Deinopoidea). *Smithsonian Contributions to Zoology* **496**: 1–52.
- Coddington JA. 1990b.** Cladistics and spider classification: araneomorph phylogeny and the monophyly of orbweavers (Araneae: Araneomorphae; Orbicularia). *Acta Zoologica Fennica* **190**: 75–87.
- Coddington JA. 1994.** The roles of homology and convergence in studies of adaptation. In: Vane-Wright R, Eggleton P, eds. *Phylogenetics and Ecology*. London: Academic Press, 53–78.
- Coddington JA, Levi HW. 1991.** Systematics and evolution of spiders (Araneae). *Annual Review of Ecology and Systematics* **22**: 565–592.
- Craig CL. 1987a.** The significance of spider size to the diversification of spider-web architectures and spider reproductive modes. *The American Naturalist* **129** (1): 47–68.
- Craig CL. 1987b.** The ecological and evolutionary interdependence between web architecture and web silk spun by orb weaving spiders. *Biological Journal of the Linnean Society* **30**: 135–162.
- Craig CL. 1994.** Predator foraging behavior in response to perception and learning by its prey: interactions between orb-spinning spiders and stingless bees. *Behavioral Ecology and Sociobiology* **35**: 45–52.
- Craig CL, Bernard GD. 1990.** Insect attraction to ultraviolet-reflecting spider webs and web decorations. *Ecology* **71** (2): 616–623.
- Dahl F. 1912.** Arachnoidea. In: Korschelt E, ed. *Handwörterbuch der Naturwissenschaften, I*, Jena: Verlag von Gustav Fischer, 485–514.
- Davies VT. 1978.** A new family of spiders (Araneae, Teemenaaridae). *Symposium of the Zoological Society of London* **42**: 293–302
- Eberhard WG. 1977.** ‘Rectangular orb’ webs of *Synotaxus* (Araneae: Theridiidae). *Journal of Natural History* **11**: 501–507
- Eberhard WG. 1981.** Construction behavior and the distributions of tensions in orb webs. *Bulletin of the British Arachnological Society* **5**: 189–204.
- Eberhard WG. 1982.** Behavioral characters for the higher classification of orb-weaving spiders. *Evolution* **36**: 1067–1095.
- Eberhard WG. 1987a.** Web-building behavior of anapid, symphytognathid, and mysmenid spiders (Araneae). *Journal of Arachnology* **14** (3): 339–356.
- Eberhard WG. 1987b.** Effects of gravity on temporary spiral construction by *Leucauge mariana* (Araneae: Araneidae). *Journal of Ethology* **5**: 29–36.
- Exline H, Levi HW. 1965.** The spider genus *Synotaxus* (Araneae: Theridiidae). *Transactions of the American Microscopical Society* **84** (2): 177–184.

- Farris JS. 1969.** A successive approximations approach to character weighting. *Systematic Zoology* **18**: 374–385.
- Farris JS. 1988.** *Hennig86 version 1.5*. Computer program distributed by its author, 41 Admiral Street, Port Jefferson Station, NY 11776.
- Foelix R. 1982.** *The Biology of Spiders*. Cambridge: Harvard University Press.
- Forster RR. 1951.** New Zealand Spiders of the Family Symphytognathidae. *Records of the Canterbury Museum* **5** (5): 231–244.
- Forster RR. 1958.** Spiders of the Family Symphytognathidae from North and South America. *American Museum Novitates* **1885**: 1–14.
- Forster RR. 1959.** The Spiders of the Family Symphytognathidae. *Transactions of the Royal Society of New Zealand* **86** (3–4): 269–329.
- Forster RR. 1970.** The Spiders of New Zealand, III. *Otago Museum Bulletin* **3**: 1–184.
- Forster RR. 1980.** Evolution of the tarsal organ, the respiratory system, and the female genitalia in spiders. In: Gruber J, ed. *Verhandlungen der 8. Internationaler Arachnologen-Kongress, Wien*. Vienna: Verlag H. Engermann, 269–284.
- Forster RR. 1988.** The Spiders of New Zealand, part VI. *Otago Museum Bulletin* **6**: 1–124.
- Forster RR, Forster LM. 1973.** *New Zealand Spiders, an introduction*. Auckland and London: Collins.
- Forster RR, Platnick NI. 1977.** A review of the Spider Family Symphytognathidae (Arachnida, Araneae). *American Museum Novitates* **2619**: 1–29.
- Forster RR, Platnick NI. 1984.** A review of the archaetid spiders and their relatives, with notes on the limits of the Superfamily Palpimanoidea (Arachnida, Araneae). *Bulletin of the American Museum of Natural History* **178**: 1–106.
- Forster RR, Platnick NI, Coddington JA. 1990.** A proposal and review of the spider family Synotaxidae (Araneae, Araneoidea), with notes on theridiid interrelationships. *Bulletin of the American Museum of Natural History* **193**: 1–116.
- Forster RR, Platnick NI, Gray MR. 1987.** A review of the spider superfamilies Hypochiloidea and Austrochiloidea (Araneae, Araneomorphae). *Bulletin of the American Museum of Natural History* **185**: 1–116.
- Gertsch WJ. 1960.** Descriptions of American spiders of the family Symphytognathidae. *American Museum Novitates* **1981**: 1–40.
- Goloboff PA. 1993.** Estimating character weights during tree search. *Cladistics* **9**: 83–92.
- Goloboff PA. 1994.** *Pee-Wee and Nonna: programs and documentation*. Available from author at Fundacion Miguel Lillo, Miguel Lillo 205, 4000 Tucuman, Argentina.
- Grasshoff M. 1968.** Morphologische Kriterien als Ausdruck von Artgrenzen bei Radnetzspinnen der Subfamilie Araneinae. *Abhandlungen von der Senckenbergischen Naturforschenden Gesellschaft* **516**: 1–100.
- Griswold CE. 1985.** *Isela okuncana*, a new genus and species of kleptoparasitic spider from southern Africa (Araneae: Mysmenidae). *Annals of the Natal Museum* **27** (1): 207–217.
- Griswold CE. 1987a.** A revision of the jumping spider genus *Habronattus* F. O. P. Cambridge (Araneae: Salticidae), with phenetic and cladistic analyses. *University of California Publications in Entomology* **107**: 1–344.
- Griswold CE. 1987b.** A review of the southern African spiders of the family Cyatholipidae Simon, 1894 (Araneae: Araneomorphae). *Annals of the Natal Museum* **28** (2): 499–542.
- Griswold CE. 1990.** A revision and phylogenetic analysis of the spider subfamily Phyxelidinae (Araneae, Amaurobiidae). *Bulletin of the American Museum of Natural History* **196**: 1–206.
- Griswold CE. 1993.** Investigations into the phylogeny of the Lycosoid spiders and their kin (Arachnida, Araneae, Lycosoidea). *Smithsonian Contributions to Zoology* **539**: 1–39.
- Griswold CE, Coddington JA, Hormiga G, Scharff N. 1994.** Phylogeny of the orb web building spiders (Araneomorphae, Orbiculariae). *American Arachnology* **50**: 5.
- Hauser DL, Presch W. 1991.** The effect of ordered characters on phylogenetic reconstruction. *Cladistics* **7**: 243–265.
- Heimer S, Nentwig W. 1982.** Thoughts on the phylogeny of the Araneoidea Latreille, 1806 (Arachnida, Araneae). *Zeitschrift für Zoologische Systematik und Evolutionsforschung* **20** (4): 284–295.
- Helsdingen PJ, van. 1965.** Sexual behaviour of *Leptyphantes leprosus* (Ohlert) (Araneidae: Linyphiidae), with notes on the function of the genital organs. *Zoologische Mededelingen* (Leiden) **41**: 15–42.
- Helsdingen PJ van. 1969.** A reclassification of the species of *Linyphia* Latreille, based on the functioning of the genitalia (Araneida, Linyphiidae), I. *Zoologische Verhandlungen* (Leiden), **105**: 1–303.
- Helsdingen PJ van. 1972.** The function of genitalia as a useful taxonomic character. In: Cestmir F, ed. *Arachnologorum Congressus Internationalis V*, Brno, 1971. Brno: Institute of Vertebrate Zoology, Czechoslovak Academy of Sciences, 239–249.

- Hickman VV. 1942.** On some new Hadrotarsidae (Araneae) with notes on their internal anatomy. *Papers and Proceedings of the Royal Society of Tasmania* **1942**: 147–160.
- Hormiga G. 1993.** Implications of the phylogeny of Pimoidae for the systematics of linyphiid spiders (Araneae, Araneoidea, Linyphiidae). *Memoirs of the Queensland Museum* **33** (2): 533–542.
- Hormiga G. 1994a.** Cladistics and the comparative morphology of linyphiid spiders and their relatives (Araneae, Araneoidea, Linyphiidae). *Zoological Journal of the Linnean Society* **111**: 1–71.
- Hormiga G. 1994b.** A revision and cladistic analysis of the spider family Pimoidae (Araneoidea, Araneae). *Smithsonian Contributions to Zoology* **549**: 1–104.
- Hormiga G, Eberhard WG, Coddington JA. 1995.** Web construction behaviour in Australian *Phonognatha* and the phylogeny of nephiline and tetragnathid spiders (Araneae, Tetragnathidae). *Australian Journal of Zoology* **43** (4): 313–364.
- Huber BA. 1993.** Genital mechanics and sexual selection in the spider *Nesticus cellulanus* (Araneae: Nesticidae). *Canadian Journal of Zoology* **71**: 2437–2447.
- Jocqué R, Bosmans R. 1982.** A new *Hahnia* from Ivory Coast with a note on stridulating organs in the Hahnidae (Araneida). *Bulletin of the British arachnological Society* **5**: 319–323.
- Kaston BJ. 1948.** *The spiders of connecticut*. Hartford: Connecticut Geological and Natural History Survey.
- Kovoor J. 1977.** La soie et les glandes séricigènes des Arachnides. *Annales de Biologie* **16**: 97–171.
- Kovoor J. 1978.** L'appareil séricigène dans le genre *Uloborus* Latreille (Araneae: Uloboridae), Données histo-chimiques. *Annales des sciences naturelles, Zoologie* **20**: 3–25.
- Kovoor J. 1986.** L'appareil séricigène dans les genres *Nephila* Leach et *Nephilengys* Koch: anatomie microscopique, histo-chimie, affinités avec d'autres Araneidae. *Revue Arachnologique* **7**: 15–34.
- Kovoor J. 1987.** Comparative structure and histochemistry of silk-producing organs in arachnids. In: Nentwig W, ed. *Ecophysiology of Spiders*. Berlin: Springer-Verlag, 160–186.
- Kraus O. 1955.** Spinnen aus El Salvador (Arachnoidea, Araneae). *Abhandlungen von der Senckenbergischen Naturforschenden Gesellschaft*, **493**: 1–111.
- Kullmann EJ. 1972.** The convergent development of orb-webs in cribellate and ecribellate spiders. *American Zoologist* **12**: 395–405.
- Lehtinen PT. 1967.** Classification of the cribellate spiders and some allied families. *Annales Zoologici Fennici* **4**: 199–468.
- Lehtinen PT. 1975.** Notes on the phylogenetic classification of Araneae. *Proceedings of the 6th International Congress of Arachnology, Amsterdam, 1974*: 26–29.
- Lehtinen PT, Saaristo MI. 1980.** Spiders of the Oriental-Australian region. II. Nesticidae. *Annales Zoologici Fennici* **17**: 47–66.
- Levi HW. 1956.** The spider genus *Mysmena* in the Americas (Araneae, Theridiidae). *American Museum Novitates* **1801**: 1–13.
- Levi HW. 1961.** Evolutionary trends in the development of palpal sclerites in the spider family Theridiidae. *Journal of Morphology* **108**: 1–9.
- Levi HW. 1980a.** Orb-webs – primitive or specialized. In: Gruber J, ed. *Verhandlungen der 8. Internationaler Arachnologen-Kongress, Wien*. Vienna: Verlag H. Engermann, 367–370.
- Levi HW. 1980b.** The Orb-weaver genus *Mecynogea*, the Subfamily Metinae and the genera *Pachygnatha*, *Glenognatha* and *Azilia* of the Subfamily Tetragnathinae North of Mexico (Araneae: Araneidae). *Bulletin of the Museum of Comparative Zoology* **149** (1): 1–74.
- Levi HW. 1981.** The American orb-weaver genera *Dolichognatha* and *Tetragnatha* north of Mexico (Araneae: Araneidae, Tetragnathinae). *Bulletin of the Museum of Comparative Zoology* **149** (5): 271–318.
- Levi HW. 1982.** Araneae. In: Parker SB, ed. *Synopsis and Classification of Living Organisms*, 2. New York: McGraw Hill, 77–95.
- Levi HW. 1983.** The orb-weaver genera *Argiope*, *Gea* and *Neogea* from the western pacific region (Araneae, Araneidae, Argiopinae). *Bulletin of the Museum of Comparative Zoology*, **150** (5): 247–338.
- Levi HW. 1986.** The neotropical orb-weaver Genera *Chrysometa* and *Homalometa* (Araneae: Tetragnathidae). *Bulletin of the Museum of Comparative Zoology* **151** (3): 91–215.
- Levi HW, Coddington, JA. 1983.** Progress report on the phylogeny of the orb-weaving family Araneidae and the superfamily Araneoidea (Arachnida: Araneae). *Verhandlungen des Naturwissenschaftlichen Vereins in Hamburg* **26**: 151–154.
- Levi HW, Eickstedt VRD Von. 1989.** The Nephilinae spiders of the Neotropics (Araneae: Tetragnathidae). *Memorias del Instituto Butantan* (Sao Paulo) **51**: 43–56.
- Levi HW, Levi LR. 1962.** The genera of the spider family Theridiidae. *Bulletin of the Museum of Comparative Zoology* **127** (1): 1–71.

- Lubin YD. 1986.** Web building and prey capture in Uloboridae. In: Shear WA, ed. *Spiders: Webs, behavior, and evolution*. California: Stanford University Press, 132–171.
- Machado A, de B. 1941.** Araignées nouvelles pour la faune portugaise. *Memórias e Estudos do Museu Zoológico da Universidade de Coimbra* **117**: 1–60.
- Maddison WP, Maddison DR. 1992.** *MacClade: Analysis of phylogeny and character evolution, version 3.0*. Sunderland: Sinauer Associates.
- Main BY. 1982.** Notes on the reduced web, behaviour and prey of *Arcys nitidiceps* Simon (Araneidae) in south western Australia. *Bulletin of the British Arachnological Society* **5**: 425–432.
- Menge A. 1866–1879.** Preussische Spinnen. 11. Abtheilungen. *Schriften der Naturforschenden Gesellschaft in Danzig* 1– 560.
- Merrett P. 1963.** The palpus of male spiders of the family Linyphiidae. *Proceedings of the Zoological Society of London* **140**: 347–467.
- Millidge, AF. 1977.** The conformation of the male palpal organs of Linyphiid spiders and its application to the taxonomic and phylogenetic analysis of the family (Araneae: Linyphiidae). *Bulletin of the British arachnological Society* **4**: 1–60.
- Millidge AF. 1980.** The erigonine spiders of North America. Part 1. Introduction and taxonomic background (Araneae: Linyphiidae). *Journal of Arachnology* **8**: 97–107.
- Nixon KC. 1992.** *Clados, version 1.2*. Program and documentation, available from author at L.H. Bailey Hortorium, Cornell University, Ithaca, NY 14853
- Opell BD. 1979.** Revision of the Genera and Tropical American Species of the Spider Family Uloboridae. *Bulletin of the Museum of Comparative Zoology* **151** (3): 443–549.
- Palmgren P. 1978a.** Taxonomic position of the genus *Meta* (Araneida). *Annales Zoologici Fennici* **15**: 241–242.
- Palmgren P. 1978b.** On the muscular anatomy of spiders. *Acta Zoologica Fennici* **15**: 1–41.
- Peters HM. 1955.** Über den Spinnapparat von *Nephila madagascariensis* (Radnetzspinnen: Fam. Argiopidae). *Zeitschrift für Naturforschung* **106**: 395–464.
- Peters HM. 1983.** Struktur und Herstellung der Fangfäden cribellater Spinnen (Arachnida: Araneae). *Verhandlungen des Naturwissenschaftlichen Vereins in Hamburg* **26**: 241–253.
- Peters HM. 1984.** The spinning apparatus of Uloboridae in relation to the structure and construction of capture threads (Arachnida, Araneida). *Zoomorphology* **104**: 96–104.
- Peters HM. 1992.** On the spinning apparatus and the structure of the capture threads of *Deinopis subrufus* (Araneae, Deinopidae). *Zoomorphology* **112**: 27–37.
- Peters HM, Kovoov J. 1980.** Un complément à l'appareil séricigène des Uloboridae (Araneae): le paracribellum et ses glandes. *Zoomorphology* **96** (1–2): 91–102.
- Peters HM, Kovoov J. 1989.** Die Herstellung der Eierkokons bei der Spinne *Polonecia producta* (Simon, 1873) in Beziehung zu den Leistungen des Spinnapparates. *Zoologische Jahrbücher. Abteilung für allgemeine Zoologie und Physiologie der Tiere* **93** (1): 125–144.
- Peters HM, Kovoov J. 1991.** The silk-producing system of *Linyphia triangularis* (Araneae, Linyphiidae) and some comparisons with Araneidae. Structure, histochemistry and function. *Zoomorphology* **111**: 1–17.
- Platnick NI, 1977.** The hypochiloid spiders: a cladistic analysis, with notes on the Atypoidea (Arachnida, Araneae). *American Museum Novitates* **2627**: 1–23.
- Platnick NI, 1989.** *Advances in Spider Taxonomy 1981–1987*. Manchester and New York: Manchester University Press.
- Platnick NI, Coddington JA, Forster RR, Griswold CE. 1991.** Spinneret Morphology and the Phylogeny of Haplogyne Spiders (Araneae, Araneomorphae). *American Museum Novitates* **3016**: 1–73.
- Platnick NI, Forster RR. 1987.** On the first American spiders of the subfamily Sternodinae (Araneae, Malkaridae). *American Museum Novitates* **2894**: 1–12.
- Platnick NI, Forster RR. 1989.** A revision of the temperate South American and Australasian spiders of the family Anapidae (Araneae, Araneoidea). *Bulletin of the American Museum of Natural History* **190**: 1–139.
- Platnick NI, Shadab MU. 1978a.** A review of the spider genus *Mysmenopsis* (Araneae, Mysmenidae). *American Museum Novitates* **2661**: 1–22.
- Platnick NI, Shadab MU. 1978b.** A review of the spider genus *Anapis* (Araneae, Anapidae), with a dual cladistic analysis. *American Museum Novitates* **2663**: 1–23.
- Platnick NI, Shadab MU. 1993.** A review of the pirate spiders (Araneae, Mimetidae) of Chile. *American Museum Novitates* **3074**: 1–30.
- Reimoser E. 1917.** Die spinnengattung *Micrathena* Sundevall. *Verhandlungen der Zoologisch-Botanischen Gesellschaft in Wien* **67**: 73–160.

- Robinson MH. 1969.** Predatory behavior of *Argiope argentata* (Fabricius). *American Zoologist* **9**: 161–173.
- Robinson MH. 1975.** The evolution of predatory behavior in araneid spiders. In: Baerends G, Beer C, Manning A, eds. *Function and Evolution in Behavior*. Oxford: Clarendon Press, 292–312.
- Roth VD, Roth BM. 1984.** A review of appendotomy in spiders and other arachnids. *Bulletin of the British arachnological Society* **6**: 137–146.
- Scharff N., in press.** Palpal function in gasteracanthine spiders (Araneae, Araneidae). *Journal of Natural History*.
- Scharff N, Coddington JA. 1997.** A phylogenetic analysis of the orb weaving spider family Araneidae (Arachnida, Araneae). *Zoological Journal of the Linnean Society* **120**: 355–434.
- Schult J, Sellenschlo U. 1983.** Morphologie und funktion der genitalstrukturen bei *Nephila* (Arach., Aran., Araneidae). *Mitteilungen aus den Hamburgischen Zoologischen Museum und Institut* **80**: 221–230.
- Sekiguchi K. 1952.** On a new spinning gland found in geometric spiders and its function. *Annotationes zoologicae Japonenses* **25**: 394–399.
- Shear WA. 1994.** Untangling the evolution of the web. *American Scientist* **82**: 256–266.
- Simon E. 1895.** *Histoire naturelle des Araignées*. Paris: Librairie Encyclopédique de Roret, Tome 1 (fasc. 4), 761–1084.
- Swofford DL. 1993.** *PAUP: Phylogenetic Analysis Using Parsimony version 3.1*. Washington: Smithsonian Institution.
- Tietjen WJ. 1986.** Social spider webs, with special reference to the web of *Mallos gregalis*. In: Shear WA, ed. *Spiders: Webs, behavior, and evolution*. California: Stanford University Press, 172–206.
- Vollrath F. 1980.** Why are spider males small? A discussion including observations on *Nephila clavipes*. In: Gruber J, ed. *Proceedings of the 8th International Congress of Arachnology, Vienna*: 165–169.
- Vollrath F, Parker GA. 1992.** Sexual dimorphism and distorted sex ratios in spiders. *Nature* **360**: 156–159.
- Wunderlich J. 1980.** Sternal-organe der Theridiosomatidae – eine bisher ürschene Autapomorphie (Arachnida: Araneae). *Abhandlungen und Verhandlungen des Naturwissenschaftlichen Vereins in Hamburg* **23**: 255–257.
- Wunderlich J. 1986.** *Spinnenfauna gestern und heute. Fossile Spinnen in Bernstein und ihre heute lebenden Verwandten*. Wiesbaden: Erich Bauer Verlag bei Quelle und Meyer.
- Wunderlich J. 1994.** Die ersten fossilen Becherspinnen (Fam. Cyatholipidae) in Baltischem und Bitterfelder Bernstein (Arachnida: Araneae). *Mitteilungen des Geologischen-Paläontologischen Instituts der Universität Hamburg* **75**: 231–241.
- Yu LM, Coddington JA. 1990.** Ontogenetic changes in the spinning fields of *Nuctenea cornuta* and *Neoscona theisi* (Araneae, Araneidae). *Journal of Arachnology* **18**: 331–345.

APPENDIX 1

*Character list, optimizations and evolution**Male genitalia*

01. Male palpal tibia: (0) normal, with all setae slender, similar to other setae on the palpal patella and femur (Fig. 11A); (1) with spiniform macrosetae, conspicuously thicker or stouter than others (Fig. 18C); (2) with one or more spur(s), which are cuticular outgrowths that may or may not be surmounted by a seta (Fig. 18F).

Forster *et al.* (1990: 110) suggested that the presence of thickened or spiniform dorsal macrosetae on the palpal femora, patellae and/or tibiae might be a synapomorphy for the Synotaxidae. These structures are quite diverse, and as yet the argument that spiniform macrosetae or other morphological modifications on different palpal segments are homologous is not sufficiently convincing. A variety of modifications of the proximal segments of the male palp may occur in the Synotaxidae, or the segments and their setae may be unmodified. Among the genera represented by these exemplars, *Chileotaxus* lacks modifications (Forster *et al.*, 1990, figs 328–330), *Meringa* has spiniform macrosetae on the tibia (as well as an elongate macroseta on the patella) (Fig. 18C; Forster *et al.*, 1990, figs. 55, 56), *Pahora* has tibial spurs, but not spiniform setae (Fig. 18F; Forster *et al.*, 1990, figs. 148, 149), and *Synotaxus* may have spiniform setae on the patella (*S. turbinatus*, *S. leticia*), or tibia (Fig. 19C) (*S. ecuadorensis*), but not both (Exline & Levi, 1965).

Our exemplar *Synotaxus turbinatus*, from La Selva, Costa Rica, has only one patellar spiniform seta. Optimization of the character on this cladogram requires origin of tibial spiniform setae in *Meringa*

and tibial spurs in *Pahora*; choice of another *Synotaxus* exemplar, e.g. *S. ecuadorensis*, would allow the character tibial spiniform setae to be a synapomorphy for Synotaxidae. This would require two losses in *Chileotaxus* and *Pahora* (as well as in those *Synotaxus* species lacking tibial spiniform setae); equally parsimonious would be convergent origin of tibial spiniform setae in *Synotaxus* and *Meringa*. In sum, the suggestion that the presence of thickened or spiniform dorsal macrosetae on the palpal femora, patellae and/or tibiae might be a synapomorphy for the Synotaxidae remains dubious.

02. *Cymbium of male palp*: (0) dorsal; (1) mesal.

Among most spiders the cymbium is dorsal to the bulb in dorsal view, but in Araneidae the orientation of the cymbium to the bulb is twisted, such that in dorsal view the cymbium is mesal to the bulb and the sclerites face laterally (Levi, 1983: 251, fig. 8).

The character is a unique synapomorphy for the Araneidae.

03. *Cymbium distal notch*: (0) absent; (1) present.

The cymbia of mysmenids are typically modified. When viewed dorsally, they are twisted and notched, with a retrolateral notch formed between a distal point and a subdistal projection (Gertsch, 1960, fig. 55; Platnick & Shadab, 1978a, fig. 17; Griswold, 1985, figs 14, 15, 26). Heimer and Nentwig (1982: 291) considered this cymbial notch to be homologous to the distal cymbial hook of theridiids (see character 11 below), but this hypothesis is refuted by character congruence. As implied by Platnick and Shadab (1978a), this cymbial modification is a synapomorphy for the Mysmenidae.

04. *Cymbium*: (0) entire; (1) constricted.

Cymbia are typically round to oval in dorsal view, wider in the mid region than at either end (Figs. 16A, 18D; Hormiga *et al.*, 1995, fig. 5a). Levi (1986) and Hormiga *et al.*, (1995) have suggested that a constricted cymbium with a mid region that is substantially narrower than either end (Fig. 10B; Hormiga, *et al.*, 1995, fig. 7c, 7h) is characteristic of true tetragnathine genera.

On this cladogram this character is a synapomorphy uniting *Tetragnatha* and *Glenognatha*.

05. *Cymbium*: (0) entire; (1) expanded retrolaterally.

When viewed ventrally, cymbia are typically about equally broad between the alveolus and prolateral and retrolateral margins (Figs 14A, 16B; Hormiga *et al.*, 1995, fig. 5b, 5h), or slightly wider retrolaterally (e.g. *Meta*: Hormiga *et al.*, 1995, 6a). In the Pimoidae (Hormiga, 1994b, fig. 46) and Cyatholipidae (Fig. 18A) the cymbium is expanded retrolaterally by an amount greater than the width of the alveolus.

On this cladogram these states are not homologous, rather a synapomorphy for Cyatholipidae and an autapomorphy for *Pimoa*.

06. *Cymbium retromarginal groove*: (0) absent; (1) present.

Forster *et al.* (1990: 110) suggested that the presence of a longitudinal incision on the retrolateral margin of the cymbium was a synapomorphy for the Synotaxidae. Such a groove is clearly present in *Synotaxus*, *Chileotaxus*, and *Meringa*, and is at least rudimentary in *Pahora*.

A possible homology with the synotaxid retromarginal cymbial groove may be found in the retromargin of the cyatholipid cymbium. In Cyatholipidae a broad, deep depression extends between the paracymbium and base of the retromedian process (see character 10), extending distad as a shallow groove between the base of that process and inner margin of the cymbium (Figs. 17C,D, 18A). The extreme retrolateral modification of the cyatholipid cymbium makes the homology criteria of similarity in form and position to Synotaxidae dubious, although the sister group relationship between Synotaxidae and Cyatholipidae suggested by other characters makes homology feasible. Nevertheless, we have taken a conservative approach and scored Cyatholipidae as lacking this feature.

On this cladogram the character is an unambiguous synapomorphy for the Synotaxidae.

07. *Paracymbium (PC)*: (0) absent; (1) present.

The presence of a retrolateral, proximal process on the cymbium (Figs 10B,C, 13B,C, 14A,B, 17C-E) has long been considered a defining character of the Araneoidea (Coddington, 1986a, 1990a, b; Hormiga *et al.*, 1995), with only the presence of similar, but presumably non homologous structures in such taxa as the Mimetidae (Platnick *et al.*, 1991) and Oxyopidae (e.g. *Tapinillus*: Griswold, 1993, fig. 56) complicating the picture.

Published accounts of paracymbial function differ dramatically. Heimer and Nentwig (1982: 288), using artificially expanded bulbs, suggested that articulation between the median apophysis and the distal 'paracymbial' hook (TCA: Figs. 15B, 16B) of theridiids fixes the expanded bulb in a position that corresponds to the final copulation position. They generalized their conclusions to all paracymbia, which they considered to be an adaptation to copulation while hanging from a space web in the absence of a firm substrate. In contrast, Levi (1961: 3) came to the conclusion that this distal hook locks the tegulum in place in the unexpanded bulb. Several accounts record interaction of the PC and median apophysis (araneids: Grasshoff, 1968; Scharff, in press) or suprategular apophysis (linyphiids:

van Helsdingen, 1965, 1969, 1972). Huber (1993), working with specimens fast-frozen in copulo, found that in *Nesticus* the PC goes into the epigynal furrow and locks into the conductor complex. He also found that artificial expansion of the bulb could be very misleading for inference of function, casting doubt on the previously cited PC functions. On the other hand, a multifarious role for the PC is not inconceivable.

The arguments for and against the homology of the distal hook of theridiids with the paracymbium of other araneoids have always been debatable (Coddington, 1990a). One scenario for PC evolution considered the theridiid distal hook homologous with the hook-like paracymbia of some other araneoids, but shifted to a position near the distal margin of the alveolus (e.g. Coddington, 1990a, character 4, state 3, 'distal').

As our knowledge of 'paracymbial' variability has increased, homology between paracymbia and juxtaposed (or not, see below) sclerotized cymbial structures within a variety of araneoid families has become increasingly difficult to specify (Hormiga *et al.*, 1995). While components within these clusters of structures may be homologous, we now know that these morphologies are very diverse, and that the problem is certainly more difficult than simply mapping one part onto another. Most of the bumps, hooks, grooves, and apophyses on the paracymbium itself or elsewhere on the cymbium seem to be autapomorphies of the taxa where they occur. For example, we now consider the theridiid distal hook (see character 11 below) as a different character from the araneoid PC, *contra* Heimer and Nentwig (1982), Forster *et al.* (1990: 114), and Coddington (1990a, fig. 108).

From a cladistic point of view, this change in interpretation has little effect on the results. Homology requires substantial morphological change in form and in position, (arguably two theridiid apomorphies), whereas non-homology requires loss of the araneoid paracymbium and gain of a novelty in theridiids (again, two theridiid apomorphies).

On this cladogram the PC is a synapomorphy for the Araneoidea with independent losses serving as synapomorphies for the derived symphytognathoids (Mysmenidae, Anapidae, and Symphytognathidae) and Theridiidae.

08. Paracymbium attachment: (0) integral; (1) flexible; (2) intersegmental.

The primitive PC is an integral outgrowth of the retrobasal margin of the cymbium (Figs 10C, 13B, 14A,B). It may differ from the cymbium in degree of sclerotization, but is otherwise not demarcated. Paracymbia may vary in the degree of sclerotization of their articulation with the cymbium, and in the position of articulation. In both linyphiids and true tetragnathines the PC attachment is membranous, but the position differs. In linyphiids the flexible attachment arises from the intersegmental membrane between the tibia and cymbium (Figs 13C, 15D; Hormiga, 1994a; Hormiga *et al.*, 1995, fig. 5a, 5b), whereas in *Tetragnatha* and *Glenognatha* the PC is retrobasal on the cymbium (Fig. 10B; Hormiga *et al.*, 1995, fig. 7c, 7d). We have chosen to further subdivide the homology hypothesis (see also Hormiga *et al.*, 1995, character 22).

On this cladogram the flexibly attached or articulated PC is a synapomorphy for the true tetragnathines; the intersegmental PC is an autapomorphy for linyphiids.

09. Paracymbium form: (0) hook; (1) squat; (2) elongate; (3) cup-shaped; (4) Linyphiid; (5) Pimoid; (6) *Meta*; (7) *Nesticus*.

The great diversity of PC shapes makes it difficult to code homologues (Lehtinen & Saaristo, 1980: 57; Coddington, 1986a, 1990a; Hormiga, 1994b; Hormiga *et al.*, 1995). As noted above, the problem has so far defied satisfactory solution, and promises to get worse. We have coded the PC into eight states, four of which represent autapomorphies for families or genera. The primitive form would appear to be a simple, short hook, broadly attached and tapering apically, as is typical of araneids, *Leucauge*, and theridiosomatids. The 'squat' PC, typical of nephilines, is short and much broader than long (Hormiga, *et al.*, 1995, fig. 5e-i). The 'elongate' PC, typical of true tetragnathines, is several times longer than wide, usually broadened at the apex, and frequently setose (Fig. 10A,B). Our coding of 'cup-shaped' PC implies homology for a broad range of forms. Forster *et al.* (1990: 100) suggested that a small, dorsally excavated PC (Figs 17E, 18C-F, 19B,C) was a synapomorphy for the Synotaxidae. This is certainly correct, as this morphology seems unique among araneoids. Interpretation of the PC of cyatholipids has been hampered by confusion between the PC and an additional, retromedian process unique to Cyatholipidae (see character 10). Ignoring the often elaborate retromedian process (e.g. *Ilisoa outeniqua* Griswold), strong similarities may be found between cyatholipid and synotaxid paracymbia. When viewed from the side, the cyatholipid PC appears to be a curved hook tapering to the tip (Fig. 17A,C). When viewed from above, this hook is deeply concave along its distal margin, forming a scoop-shaped structure with mesal and ectal walls (Fig. 17D). The mesal wall, bordering the tegulum, is the higher of the two, forming an excavation that is essentially apicodorsal (Fig. 18A,

B). Whereas the gross morphology of synotaxid and cyatholipid paracymbia differs, each is dorsally excavated. The retrolateral cymbial hypertrophy characteristic of cyatholipids (character 5) may have radically altered a simple PC cup. The homology between PC form in synotaxids and cyatholipids is crucial to this hypothesis, being a synapomorphy uniting these two families. The four remaining states, linyphiid (Fig. 13C), pimoid (Fig. 13B), *Meta* (Fig. 10C), and *Nesticus* (Fig. 14A,B), represent paracymbia so modified that we consider it better to accept the loss of information incurred in coding these as autapomorphies rather than speculate on special similarities with other PC forms.

10. *Retromedian process on cymbium*: (0) absent; (1) present.

The retrolateral margins of cyatholipid cymbia have a unique median process (RMP: Figs 17A,C, D, 18A,B). This structure is often considered to form part of a 'bipartite paracymbium': in fact, the cyatholipid PC is cup-shaped (see character 9).

This retromedian cymbial process, newly characterized here, is a synapomorphy for the Cyatholipidae.

11. *Hook located distally on cymbium near alveolar margin*: (0) absent; (1) present.

As explained above, theridiids lack a retrobasal paracymbium but have a hook (TCA: Fig. 16B,E), (or occasionally, a cavity, e.g. *Anelosimus*, Fig. 16A) that interacts with a tegular process to arrest the movement of the bulb. The form of the distal hook in *Steatoda*, *Dipoena*, and *Euryopis* is similar to the PC morphology that we score as 'hook' (see character 9, state 0), although we reject homology (see above). Levi (in litt.) has pointed out that in primitive theridiid genera (e.g. *Enoplognatha*, *Latrodectus*, *Steatoda*, as judged by retention of colulus), the 'paracymbium' is more like that in other araneoids than it is for more derived theridiid genera.

On this cladogram this hook is a synapomorphy for the Theridiidae.

12. *Unexpanded bulb-cymbium lock mechanism*: (0) absent; (1) present.

This internal arresting mechanism for the unexpanded bulb (Levi, 1961: 3) involves the interaction of the distal cymbial hook (character 11) with the tegulum (Fig. 15A,B). The current character codes for the corresponding modification on the tegulum which functions with the cymbial structure to arrest the unexpanded bulb.

On this cladogram, the mechanism is a synapomorphy for the theridiids.

13. *Reservoir*: (0) normal; (1) enlarged.

The reservoir of tetragnathines has a greatly enlarged diameter (Fig. 10A), with a single simple spiral nearly filling the tegulum and constituting a clear synapomorphy for *Tetragnatha* plus *Glenognatha* (Hormiga *et al.*, 1995). Typical of other tetragnathids is a slender reservoir with a complex course, including switchbacks. Hormiga *et al.* (1995) suggest that reversion to a simple spiral in tetragnathines is another synapomorphy; the simple course of the tetragnathine reservoir may be a consequence of its great enlargement, filling the tegulum and leaving no room for switchbacks.

14. *Conductor (C)*: (0) present; (1) absent.

Homology of the palpal sclerites of male spiders is among the most difficult, and most crucial, mysteries in spider phylogeny. Use, and misuse, of a small set of standard terms for a great variety of structures has at times further clouded the picture. Coddington (1990a) attempted to make sense out of this confusion by setting a logical baseline against which to judge the homology of the myriad structures found on spider palps. Bhatnagar and Rempel (1962), found that the C and median apophysis (MA) were intimately associated in male palp ontogeny. They arise from the dorsal lobe of the pedipalpal claw fundament, whereas all other parts of the palp (e.g. subtegulum, tegulum, embolic division plus its associated sclerites in complex palpi, and the sperm duct) develop from the ventral lobe of the claw fundament. At the last stage of pedipalpal ontogeny the C and MA differentiate and insert on the tegulum: either might easily come to be closest in position to the embolus in the mature palp.

We face this dilemma by adopting an arbitrary but uniform rule for homology decisions regarding the C and MA. If there is only one tegular sclerite (in addition to the embolus), we consider this to be the C. This reasoning has been used previously (Coddington, 1990a,b; Platnick *et al.*, 1991; Hormiga, 1994a). While the decision to allocate homoplasy in loss to the MA in favor of the C is arbitrary in really ambiguous cases, we note that if single, tegular processes are usually associated with the embolus or embolus tip (i.e. they seem to function like conductors).

On this cladogram the C is lost independently in Linyphiidae and in the derived symphytognathoids (mysmenids, anapids, and symphytognathids), with a remarkable reversal to present in *Anapis* (Figs 11B, 12C). This implies that the C of *Anapis* may not be the homologue of the C of other Orbiculariae (or spiders in general). Therefore, it is hardly surprising that the tegular structure in *Anapis* called conductor (Platnick & Shadab, 1978b, figs 4, 14–16) differs from that in all other araneoids.

15. *Conductor*: (0) simple; (1) complex.

The tegula of synotaxids are surmounted apically by a complex collection of processes (Fig. 19B, C). In the past these processes have been interpreted as comprising the full gamut of araneomorph tegular processes, though the interpretations differed in detail. Forster *et al.* (1990) noted these complex structures but referred to them simply as ‘apophyses’ without suggesting more specific homology to the tegular processes of other spiders. Exline and Levi (1965, fig. 2) recorded a C, MA, and radix in *Synotaxus turbinatus*. Coddington (1990a, fig. 89) interpreted these apparently independent processes in the same way, but reinterpreted the ‘radix’ as the ‘theridiid tegular apophysis’ (TTA). In Coddington’s definition the TTA is an outgrowth of the tegular wall, not homologous with the MA, that contains part of the course of the reservoir (e.g. Coddington, 1990a, figs 77, 82, 86). Expansion of the bulbs of representatives of all four synotaxids in this study has allowed more detailed comparison of these distal processes. In each case a large, sclerotized structure with two or more processes is flexibly attached at the apex of the bulb, near to (and in *Meringa* and *Pahora* hiding) the base of the spiral embolus (Fig. 19B,C). One can grasp any one of these ‘tegular’ processes and wiggle all of them together, indicating that they all form one apically inserted tegular process. In no case does the reservoir pass through any part, ruling out homology with the TTA of theridiids. Given the decision to accept the basic homology of tegular processes with the C and MA before postulating the appearance of new structures, and the decision to allocate homoplasy in loss (if required) to the MA (see character 16 below), we conclude that this large, complex structure in synotaxids is the C.

This complex form, newly characterized here, is a synapomorphy for the Synotaxidae.

16. *Median apophysis (MA)*: (0) present; (1) absent.

As discussed above under character 14, the problem of homology of palpal sclerites must be solved in a way that is partially arbitrary. We have chosen as a rule of thumb to allocate homoplasy in loss of tegular processes to the MA (Coddington, 1990a; Platnick *et al.*, 1991; Hormiga *et al.*, 1995).

On this cladogram presence of a MA is considered primitive for Orbiculariae, because a conductor and median apophysis are generally distributed in the ‘RTA clade’, suggesting that these structures are primitive for that group and their putative sister group, the Orbiculariae. The situation is ambiguous in the Deinopoidea, with the MA present in Uloboridae and absent in Deinopidae. As noted above, we have chosen to favour the homology of the MA wherever a second tegular process is found in Araneoidea. To do otherwise would require independent origins of new structures, not homologues of the MA of other spiders, in Araneidae, Theridiosomatidae, Pimoidae, and the theridiid-nesticid lineage.

The hypothesis that the MA is primitive for Orbiculariae requires independent losses of this structure in Deinopidae, Tetragnathidae (Fig. 10A,C), derived symphytognathoids (Figs 11A–C, 12A–D), Linyphiidae (Fig. 13C), some pimoids, *Euryopsis* (Fig. 16D), and Cyatholipidae plus Synotaxidae (Fig. 19A–C).

17. *Tegular processes*: (0) subterminal; (1) terminal.

Tegular sclerites vary in their insertion on the tegulum (Hormiga *et al.*, 1995). In most tetragnathids (Fig. 10A,C), linyphiids (Fig. 13C), and synotaxids (Fig. 19B,C), the tegular sclerites are grouped together (if multiple) and terminal on the tegulum. In other taxa various sclerites insert subterminally (e.g. Figs 14B, 19A).

On this cladogram terminal insertion arises independently in Tetragnathidae, Synotaxidae, and Linyphiidae.

18. *Additional tegular processes*: (0) absent; (1) present.

We accept that, in addition to the embolus, two sclerites insert primitively on the tegulum: C and MA (see characters 14 and 16 above). Therefore, in assessing the homology of tegular sclerites, these candidates must be accounted for before additional or *de novo* sclerites are considered. Additional processes have been identified in the theridiid-nesticid lineage and in pimoids: while different in structure, we coded them as potential homologues and let parsimony decide the matter. In Pimoidae the pimoid embolic process (PEP of Hormiga, 1994b), autapomorphic for that family, consists of a slender, elongate arching sclerite arising near the embolic base (Fig. 13B). In the theridiid-nesticid lineage (with the exception of *Euryopsis*) the additional process consists of a swelling of the tegular wall, frequently containing a loop of the reservoir (Figs 15B, 16C). This is the ‘theridiid tegular apophysis’ (TTA) of Coddington (1990a, also termed ‘tegular lobes’; also Hormiga, *et al.*, 1995), and constitutes a synapomorphy for the Theridiidae plus Nesticidae.

19. *Conductor and embolus*: (0) separate; (1) conductor wraps embolus.

Coddington (1990a) used Millidge’s (1977) concept of ‘palp conformation’ to define the ‘metine palp conformation’, which, incidentally, was characteristic of all tetragnathids. It now seems best to avoid such ensemble characters and instead to reduce complex descriptions as nearly as possible to

elemental comparisons. Essential to the “metine palp conformation” is a C that spirals with and wraps the embolus for most of its length (Fig. 10A,C), rather than cradling or opposing the embolus (‘separate’).

On this cladogram the C wrapping E is a synapomorphy for the Tetragnathidae (also Hormiga *et al.*, 1995).

20. *Araneid radix*: (0) absent; (1) present.

In most araneoids, the embolus inserts directly on the tegulum. Notable exceptions are found in the Araneidae and Linyphiidae. Previously, the intercalary sclerites present between the tegulum and embolus, through which the reservoir runs, were scored as homologues in these families though the homology was dubious. For Coddington, (1990a, character 22) the radix served as a synapomorphy for Araneidae plus Linyphiidae, but in a later paper (1990b, character 36) his results showed independent derivation of this structure in these two families. Hormiga (1994a, character 22) considered the araneid-linyphiid homology dubious, taking into account differences in linyphiid and araneid ‘radices’ and the absence of such a structure in pimoids, but conceded that if araneids are sister to pimoids plus linyphiids, homology of the radices would be the most parsimonious hypothesis. Scharff and Coddington (1997) provide a strict definition of the araneid radix as an intercalary sclerite present between the tegulum and the embolus. The sperm duct runs from the tegulum through the radix to the embolus proper. Their character coding scheme allowed for the possible homology in linyphiid and araneid radices, but their cladogram unambiguously required independent derivation.

We accept that the weight of recent evidence suggests that the araneid radix is unique and not homologous with similar structures in Linyphiidae, a situation that would not change even if the character had been scored for linyphiids as well.

21. *Embolus base*: (0) exposed; (1) invaginated in tegulum.

In the *Anapis* and *Mysmena* exemplars the base of the embolus is deeply invaginated in the tegulum such that the exposed portions represent half or less of the total embolus length. The embolus may be visible through the tegular cuticle. In *Anapis* (Fig. 12C) the embolus makes a tight turn before emerging through a groove in the C; in *Mysmena* (Fig. 12B) the embolus makes three internal turns before emerging to make an additional turn in the external tegular groove.

We are unaware of a similar situation in any other spider, and initially thought that this could be an anapid/mysmenid synapomorphy. The embolic bases are exposed in *Gertschanapis* and *Maymena* (Fig. 12A), and the weight of evidence suggests that the invaginated embolic base is independently derived in *Anapis* and *Mysmena*.

22. *Embolus-tegulum membrane*: (0) absent; (1) present.

A membranous connection between the base of the embolus and the tegulum is present in all tetragnathids that we have examined (Hormiga *et al.*, 1995, figs 8–13), in linyphiids (where it is referred to as the column), and in araneids basad of the radix. Schult & Sellenschlo (1983) incorrectly homologized the embolus-tegulum membrane with the araneid distal hematodocha. The latter membrane is distal to the radix (a sclerite that is absent in tetragnathids), and connected to the stipes (absent in tetragnathids and linyphiids) and/or subterminal/terminal apophysis and/or embolus. It could be argued that the tetragnathid embolus-tegulum membrane is homologous to the membrane connecting the araneid radix to the tegulum (and that this structure is lost in the derived araneoids), but we lean towards non-homology in araneids and tetragnathids (as in Hormiga *et al.*, 1995). The linyphiid column (the membrane that connects the suprattegulum to the ‘linyphiid radix’; see Hormiga, 1994b) is clearly an independent derivation (Fig. 13C).

23. *Embolus-tegulum orientation*: (0) parallel; (1) 90 degrees.

Right-angle orientation of the embolus-conductor in relation to the longitudinal axis of the pedipalp (e.g. Hormiga *et al.*, 1995, fig. 9A) occurs only in and is a characteristic apomorphy of derived nephilines (i.e. at least *Clitaetra*, *Herennia*, *Nephilengys*, and *Nephila*).

Female Genitalia

24. *Female genitalia*: (0) entelegyne; (1) haplogyne.

The presence of separate copulatory ducts opening on the ventral body wall and fertilization ducts that connect the spermathecae to the gonoduct independently of the copulatory openings is a synapomorphy for a major group of araneomorph spiders, though with sporadic reversions to haplogyny through loss of the fertilization ducts (Platnick *et al.*, 1991). Secondary haplogyny has long been known in some uloborids (Opell, 1979) and tetragnathines (Levi, 1980b, figs 181, 182; Coddington, 1990a; Hormiga *et al.*, 1995); recently Platnick and Forster (1989) demonstrated that the anapids are also generally haplogyne.

On this cladogram secondary haplogyny evolves independently in the Anapidae and Tetragnathinae.
 25. *Spermathecae*: (0) separate; (1) connate.

Coddington (1986c) found that spermathecae fused along the midline and that share the median wall ('connate') are synapomorphic for the theridiosomatids. This configuration is found in all theridiosomatids (though in some genera, e.g. *Baalzebub*, *Epilineutes*, the spermathecal fusion is restricted to the distal tips), and we have not observed this character in any other Orbiculariae. On this cladogram the character is a synapomorphy for the Theridiosomatidae.

26. *Spermathecae*: (0) 2; (1) 4.

The presence of two pairs of spermathecae has been used to distinguish the hadrotarsines (e.g. *Dipoena*, *Euryopsis*) from other theridiids (Levi & Levi, 1962). Laterally paired or bilobate spermathecae have also been recorded in most species of the haplogyne genus *Tetragnatha* (Levi, 1981). All other exemplars in this study have a single spermatheca on each side. Although Forster (1980: 283) has suggested that bilobed spermathecae among entelegynes represent a plesiomorphic retention (the simple bireceptaculate form having arisen through loss of one or fusion of both receptacula on each side), parsimony suggests that, at least within Orbiculariae, laterally paired spermathecae are derived.

On this cladogram four spermathecae are a synapomorphy for the hadrotarsine theridiids and a non homologous autapomorphy for *Tetragnatha* (Fig. 10F). Levi (1981: 274) suggests that the median of the two receptacles in *Tetragnatha* is not a spermatheca at all, but might serve as a holdfast for the C.

Cephalothorax

27. *AME*: (0) present; (1) reduced or absent.

The reduction (*Gertschanapis*) or loss (*Anapis*, Fig. 20A, *Patu*, Figs. 11D, 21A) of the anterior median eyes is a synapomorphy for a clade containing Anapidae and Symphytognathidae (Coddington, 1990a).

28. *PME tapetum*: (0) present; (1) absent.

Presence of tapeta in secondary eyes is generally plesiomorphic in spiders. Deinopoids lack tapeta altogether, but most araneoids have tapeta in some of their eyes. Among tetragnathids, some genera lack tapeta in median eyes (i.e. *Pachygnatha*) and some, including *Tetragnatha*, in both posterior and median eyes (Levi, 1981: 274; Coddington, 1990a, b; Hormiga *et al.*, 1995).

On this cladogram loss of the PME tapetum arises twice: as a synapomorphy for the tetragnathines (*Tetragnatha* and *Glenognatha*) and for the Deinopoidea (Deinopidae and Uloboridae).

29. *PME tapetum*: (0) normal; (1) narrow.

In the plesiomorphic araneoid condition the midline or 'keel' of the canoe tapetum bisects the eye cup, and the rhabdoms and tapetum are equally displayed on both sides. In the derived condition, the canoe keel and the PME tapetum is much displaced towards the sagittal plane; on the ectal side the rhabdoms loop back and forth (Levi & Coddington, 1983; Coddington, 1990a).

On this cladogram the unusual tapetal structure of the posterior median eyes is a synapomorphy for the Araneidae.

30. *Male lateral eyes*: (0) separate; (1) juxtaposed.

In nearly all araneoids, the lateral eyes are juxtaposed (e.g. Fig. 20D). The lateral eyes are separate in some tetragnathids, linyphiids, and *Latrodectus* among the theridiids, but overall juxtaposed is quite general. Even in those cases in which the lateral eyes of the female are separate, those of the male are juxtaposed (e.g. *Nephilengys cruentata*). In Deinopoidea the lateral eyes are usually separated by at least their diameter. Coddington (1990a, b) suggested that the derived presence of juxtaposed lateral eyes in araneoids corroborates the monophyly of Araneoidea, a suggestion followed by Hormiga *et al.* (1995) and repeated on this cladogram.

31. *Clypeus height*: (0) less than AME diameter; (1) greater than AME diameter.

Outgroup comparison with Deinopoidea suggests that a high clypeus (Fig. 20A, D) is a synapomorphy for the Araneoidea. The low clypeus of *Metepeira* is a reversal. (see also Coddington, 1990b; Hormiga *et al.*, 1995).

32. *Male size*: (0) greater than or equal to 0.5 female; (1) less than 0.3 female.

Males and females are of nearly the same size (defined here as male greater than 0.5 size of female) in deinopoids and most orbicularians. Sexual dimorphism in size (a male that is less than 0.3 the size of the female) evolves twice: in *Angiope* and in the higher nephilines. Sexual size dimorphism in nephilines is better thought of as female giantism, not male dwarfism (*contra* the traditional view, e.g. Vollrath, 1980; Vollrath & Parker, 1992), because male size in nephilines is either comparable to or larger than male size in tetragnathid outgroups (Hormiga *et al.*, 1995; Coddington, 1994). The situation differs in *Angiope*, in which males are usually smaller than most araneid males.

33. *Size of male vs. female chelicerae*: (0) same; (1) larger.

In the Orbiculariae male and female chelicerae are typically about the same size. It has been suggested (Levi, 1986; Hormiga *et al.*, 1995) that large male chelicerae typified several tetragnathid genera. On this cladogram large chelicerae arise three times: a synapomorphy for *Tetragnatha* and *Glenognatha*, and independently in *Linyphia* and *Anapis*.

34. *Fangs*: (0) normal; (1) elongate in the hadrotarsine fashion.

Forster *et al.* (1990: 110, 111) noted that the classical hadrotarsids (*Hadrotarsus*, *Gmogola*, *Guaraniella*, and *Yoroa*) share a number of unique features with a group of genera traditionally placed in the Theridiidae (i. e. *Anatea*, *Audifia*, *Dipoena*, *Dipoenata*, *Euryopsis* and *Lasaeola*). In these taxa the fang is long and slender (Fig. 10D; Forster, *et al.*, 1990, fig. 392), reaching from the apex of the shortened paturon (see character 35 below) to the tip of the palpal endites.

On this cladogram the character is a synapomorphy for the hadrotarsine genera *Dipoena* and *Euryopsis*.

35. *Paturon*: (0) normal; (1) short.

A cheliceral paturon that is so shortened that the distal end does not reach the tips of the palpal coxal endites was another of the peculiarities noted for the classical hadrotarsids and certain theridiid genera (Fig. 10D; Forster *et al.*, 1990: 111, fig. 392). On this cladogram the character is a synapomorphy for the hadrotarsine genera *Dipoena* and *Euryopsis*.

36. *Cheliceral teeth origin*: (0) sessile; (1) from mound.

Typical of the chelicerae of anapids and symphytognathids is the origin of teeth from a large mound or at least from a common base (Figs 20B, 21B; Platnick & Shadab, 1978b, fig. 7; Forster & Platnick, 1977, figs 3, 36). On this cladogram the morphology is a synapomorphy uniting the Anapidae and Symphytognathidae.

37. *Ectal surface of male chelicerae*: (0) smooth; (1) with stridulating file.

Hormiga (1994a, b; Hormiga *et al.*, 1995) discusses this character in the linyphiids and pimoids. Similar cheliceral striae have also evolved in several distantly related araneomorphs: some Archaecidae, Mecysmaucheniiidae, and Pararchaeidae (Forster & Platnick, 1984); Mimetidae (*Eno*, Machado, 1941); Hahniiidae (*Hahnia*, Jocqué & Bosmans, 1982); Austrochilidae and Gradungulidae (Forster, Platnick & Gray, 1987); Tetragnathidae (*Meta*) and Spatiatoridae (fossil) (Wunderlich, 1986); Gasteracanthinae (*Gasteracantha mammosa*), and Amaurobiidae Phyxelidinae (Griswold, 1990).

The most parsimonious hypothesis to explain the available data is to postulate a single origin for the cheliceral striae of linyphiids and pimoids, and to regard the striae in other spider lineages as independently evolved. On this cladogram the feature is a synapomorphy for Linyphiidae plus Pimoidae.

38. *Chelicerae*: (0) free; (1) fused.

Fusion of the chelicerae along the midline (Figs 11D, 21A), ranging from only the base to the full length of the paturon, has long been recognized as a synapomorphy for the Symphytognathidae (Forster & Platnick, 1977; Coddington, 1986a).

39. *Cheliceral boss*: (0) smooth; (1) striated.

The cuticle of the cheliceral boss of Orbiculariae is primitively smooth (Hormiga *et al.*, 1995, fig. 27A,B). In higher nephiline tetragnathids this cuticle has been modified into a striated pattern (Hormiga *et al.*, 1995, figs 27C,D, 28A–29B). The cheliceral boss is absent in most derived araneoids (Fig. 20D).

40. *Labrum*: (0) simple; (1) with spur.

The presence of an anterior-directed spur on the labrum (Fig. 20C) was first suggested as a synapomorphy for the Anapidae by Platnick and Shadab (1978b). (see also Coddington, 1986a).

41. *Labium*: (0) length > width; (1) length ≤ width.

This classical character was also used by Coddington (1990a, b), who found that a longer than wide labium is primitive for the Orbiculariae. Like all observations based on a quantitative ratio, the definition can exaggerate differences between taxa that are not very different. However, on this cladogram a broad labium (Fig. 21C) is a synapomorphy for the Araneoidea, with reversals to an elongate form in *Nephila* and *Pahora*.

42. *Sternal pits*: (0) absent; (1) present.

Wunderlich (1980) first noted these structures, which appear as deep pits on the promargin of the sternum, adjacent to the labium, as theridiosomatid apomorphies (Coddington, 1986c, figs 76, 85, 140). Cleared preparations reveal them to be glandular structures, with sac-like invaginations (Wunderlich, 1980, figs 3, 4). Coddington (1986c) listed these pits as a synapomorphy for Theridiosomatidae, present in all but the presumably antapomorphic genus *Chthonos*. On this cladogram the feature remains a synapomorphy of Theridiosomatidae.

43. *Sternum posterior apex*: (0) pointed; (1) truncate.

This classic character and has often been used to separate certain small araneoids from others (Simon, 1895; Kaston, 1948; Levi, 1982). Its utility in phylogenetics was criticized by Coddington (1986c) due to imprecision in definition, reliability of observation, homoplasy, and the possible influence of overall body proportions on sternum shape. While smaller spiders do tend to have truncate sterna, the rule is not universal. Small spiders may have pointed sterna (e.g. *Maymena*, some small theridiids) and larger spiders may have truncate sterna (Cyatholipidae and Synotaxidae). The truncate sternum is defined here as one in which the posterior margin makes a straight line perpendicular to the long axis of the body with a breadth greater than or equal to the diameter of a fourth coxa (Fig. 21C).

On this cladogram the truncate sternum arises independently four times: in *Glenognatha*, as a synapomorphy for the Symphytognathoidea (with a reversal to pointed in *Maymena*), as a synapomorphy for the Hadrotarsinae (*Dipoena* plus *Euryopis*) and as a synapomorphy for the Synotaxidae plus Cyatholipidae.

44. *Caudal gut caeca*: (0) absent; (1) present.

Palmgren (1978a, b) found that tetragnathids (e.g. *Tetragnatha*, *Pachygnatha*, *Glenognatha*) have bulky ventral caeca that extend into the chelicerae and pedipalpal coxae. He also found a posterior, unpaired dorsal caecum occupying the space between the tergo-dorsal muscles and the dorsal apodeme in these genera. Araneids, *Meta*, and 62 species of 24 other European families that Palmgren (1978a) studied lack these features. Although these observations admittedly argue against *Meta* as a tetragnathid, they are overruled by the combined data that place *Meta* firmly within Tetragnathidae. However, the character is unknown for the symphytognathoid and cyatholipoid families.

Abdomen/legs

45. *Abdominal stridulating file*: (0) absent; (1) present.

Males of the synotaxid subfamilies Pahorinae and Physogleninae have modifications of the anterior surface of the abdomen and pedicle and/or posterior region of the carapace that presumably function in stridulation. Details vary between the two subfamilies. In *Meringa* (Physogleninae) the abdomen has an anterior, dorsal transverse ridge below which the cuticle is concave and furnished with small ridges: these interact with expanded, corrugated lateral lobes of the pedicle (Forster *et al.*, 1990, fig. 33). In *Pahora* (Pahorinae) the abdomen has a similar file that interacts with a pick on the posterior margin of the carapace (Forster *et al.*, 1990, figs. 135,136). In both cases a file on the abdomen interacts either with the pedicle or carapace. The abdominal files are sufficiently similar to hypothesize homology in the stridulatory behaviours. Other examples of carapace-abdomen stridulating structures exist, such as in jumping spiders of the *Habronattus agilis* group (Griswold, 1987a) and in the theridiid genus *Steatoda* (Forster & Forster, 1973, fig. 4b), but in these cases the file is on the carapace and the pick mechanism on the abdomen and thus probably not homologous to the synotaxid condition.

On this cladogram the stridulating mechanism is a synapomorphy linking *Meringa* and *Pahora*.

46. *Deinopoid abdominal tubercles*: (0) absent; (1) present.

Deinopids and uloborids usually have characteristic paired bumps or tubercles on the abdomen (e.g. Opell, 1979, figs. 74, 122; Coddington, 1990a). This character supports the monophyly of the Deinopoidea.

47. *Dorsal scutum on male abdomen*: (0) absent; (1) present.

Although abdominal scuta occur sporadically among araneoid genera, e.g. in *Witica* and several gasteracanthine genera (Araneidae), *Matilda* (Cyatholipidae), *Pholcomma* (Theridiidae), and Erigoninae (Linyphiidae), only in Anapidae are scuta so generally distributed as to be possibly plesiomorphic for the family. Given the selection of exemplars, a male abdominal scutum is synapomorphic for Anapidae. A male dorsal abdominal scutum apparently arose independently in some nephilines (Hormiga *et al.*, 1995).

48. *Anterior book lungs*: (0) present; (1) modified.

Unmodified anterior book lungs are clearly plesiomorphic for Araneomorphae (Platnick, 1977; Platnick *et al.*, 1991). Replacement of anterior book lungs by tracheae has long been considered a derived feature of the symphytognathoid families (e.g. Forster, 1959). There has never been any controversy regarding the absence of book lungs in symphytognathids and anapids, but the situation in mysmenids is ambiguous, and our data come primarily from the literature. Spiders attributed to '*Mysmena*' (the genus has since been split) lack book lungs (e.g. Forster, 1959, figs 147–148; Levi, 1956). On the other hand, Gertsch (1960: 31) reported that *Maymena* has book lungs. On Figure 9, modification of the anterior book lungs is a synapomorphy for Anapidae plus Symphytognathidae with parallel reduction in the minute *Mysmena*.

49. *Booklung cover*: (0) grooved; (1) smooth.

The presence of grooves on abdominal booklung covers (Fig. 23D) is a classic morphological character in araneoid taxonomy (e.g. Simon, 1895; Kaston, 1948). Smooth booklung covers (Fig. 23C) occur in potential orbicularian outgroups, whereas grooved booklung covers occur in Deinopidae, Araneidae, and *Meta* and the nephilines among the Tetragnathidae.

Grooved booklung covers are probably an orbicularian synapomorphy, with parallel losses for uloborids, *Leucauge* plus the tetragnathines and the clade including symphytognathoids, linyphioids, and theridioids. The grooves in *Nesticus* are a parallelism.

50. *Posterior tracheal spiracle*: (0) narrow; (1) broad.

We define a 'broad' tracheal spiracle to be wider than the width of the base of the spinnerets (Fig. 23B). Controversy exists as to whether the cyatholipid morphology is one spiracle (Davies, 1978: 286) or an external groove connecting two widely spaced spiracles (Forster, 1988: 11). The sagittal section of *Teomenaenus* presented by Davies (1978, fig. 19) suggests that it is the former. Two spiracles or one, the morphology is synapomorphic for Cyatholipidae on this cladogram.

51. *Setae*: (0) plumose; (1) serrate.

Plumose setae (Fig. 22C) are primitive for the Araneocladia. Lehtinen (1975: 27) commented that both the cuticle texture and setal morphology of araneoids are so distinctive that one can identify araneoids "by means of a fragment of a leg only." The distinctive serrate setae (Figs. 22E, G) are a synapomorphy for the Araneoidea (Coddington, 1986a, 1990a,b).

52. *Female palp size*: (0) normal; (1) reduced to absent.

Reduction or loss of the female palp has long been considered a defining feature of the 'symphytognathid' spiders in the traditional sense, referring to spiders now placed in the Symphytognathidae and Anapidae (Forster, 1951, 1958, 1959; Gertsch, 1960). Coddington (1990a) corroborated that reduction in palpal size, number of segments, or complete loss (Fig. 21A), is a synapomorphy for the Anapidae plus Symphytognathidae, a conclusion born out here.

53. *Female palpal claw*: (0) present; (1) absent.

The presence of a claw on the tarsus of the female palp is certainly plesiomorphic in spiders, but the phylogenetic significance of its absence is more problematic. Platnick *et al.* (1991) showed that this character is highly homoplasious in Araneomorphae, and suggested that loss of the claw could occur independently, and that the claw could reappear (e.g. in leptonetids, some dysderoids, and archaeids). Hormiga (1994a) discussed homoplasy in this character in linyphiids.

On this cladogram loss of the female palpal claw occurs twice: as a synapomorphy for the symphytognathoid families (scored as '?' for *Gertschanapis* and symphytognathids, which lack the female palpal tarsus), and as a synapomorphy for the Cyatholipidae (Fig. 22D).

54. *Female palpal claw*: (0) attenuate; (1) palmate.

Hickman (1942) illustrated a remarkable female palpal claw in Hadrotarsidae that is flattened and broadened distally with several apical teeth (Fig. 10E; Hickman, 1942, fig. 25). Forster *et al.* (1990) found the same morphology in several theridiid genera as well as other similarities, and subsumed Hadrotarsidae within Theridiidae. Here the unique claw type is a synapomorphy for the hadrotarsines *Dipoena* and *Euryopis*.

55. *Femora basally thickened*: (0) no; (1) yes.

The leg femora of some Cyatholipidae and Synotaxidae are gracefully yet abruptly expanded near the base (Fig. 20D). Forster *et al.* (1990: 110) suggested that such basally thickened femora might be a synapomorphy for the Synotaxidae, but the femora of *Synotaxus* are nearly cylindrical.

On this cladogram basally thickened femora arise twice: as a synapomorphy for the synotaxid genera *Chileotaxus*, *Meringa* and *Pahora* and independently in the cyatholipid *Isicabu*. This result could change with understanding of the groundplan in Synotaxidae or Cyatholipidae. Genera other than *Isicabu* also have basally thickened femora: if this is the groundplan state for Cyatholipidae, this character could become yet another synapomorphy for Cyatholipidae plus Synotaxidae.

56. *Femoral sclerotized spot*: (0) absent; (1) present.

The presence of a small, sclerotized spot (Fig. 10G) located subapically on the venters of femora I and II of at least female mysmenids has previously been suggested as a synapomorphy for this family (Platnick & Shadab, 1978a; Coddington, 1986a), a conclusion born out on this cladogram.

57. *Male metatarsus I megaspine*: (0) absent; (1) present.

Mysmena has a stout anteroventral spine near the base of metatarsus I, whereas *Mysmena* has a sinuate spine about midway along the shortened metatarsus. As previously suggested by Platnick and Shadab (1978a: 5), these male metatarsal clasping spines are a mysmenid synapomorphy.

58. *Femur IV trichobothria*: (0) absent; (1) present.

In our data set femoral trichobothria are unique to uloborids and to the tetragnathids *Tetragnatha*,

Glenognatha, and *Leucauge*. The possibility that this trichobothrial pattern could link uloborids and tetragnathids has intrigued previous workers (Opell, 1979; Levi, 1980b; Coddington, 1990a; Hormiga *et al.*, 1995), but as in these previous studies, our results suggest that femoral trichobothria have evolved independently in the uloborids and tetragnathids.

59. *Femoral macrosetae*: (0) present; (1) absent.

Socketed macrosetae, often referred to as ‘spines’, are nearly universal on the araneomorph femora. Exceptions include the Dictyninae and certain orbicularian taxa. Wunderlich (1986) linked cyatholipids (but not synotaxids) with the theridiid-necticid lineage because their femora and metatarsi lacked macrosetae, and this study confirms it. On this cladogram the loss of femoral macrosetae happens four times: as a synapomorphy for theridioids and cyatholipoids, in *Glenognatha*, in *Mysmena*, and as a synapomorphy for Anapidae plus Symphytognathidae. This absence of femoral spines is not related to size reduction: femoral spines are present in small spiders such as theridiosomatids and *Maymena*, and absent in large theridiids such as *Steatoda*.

60. *Patella-tibia autospasy*: (0) absent; (1) present.

Autospasy of legs at the patella-tibia junction occurs sporadically among araneomorphs: in filistatids, leptonetids, hersiliids (Roth & Roth, 1984). Among the araneoids, this type of autospasy is a unique synapomorphy for Linyphiidae plus Pimoidae (Roth & Roth, 1984; Hormiga, 1994a, b; Hormiga, *et al.*, 1995).

61. *Tibia IV dorsal trichobothrium length*: (0) normal; (1) greater than 3 times tibia diameter.

The dorsal tibial trichobothria of theridiosomatids are extraordinarily long, being greater than three times the diameter of the segment. Tibial trichobothria of other Orbiculariae are much shorter. These long trichobothria are a synapomorphy for theridiosomatids (Coddington, 1986c).

62. *Tarsus IV comb*: (0) deinopoid type; (1) lacking; (2) theridiid type.

On most araneomorphs the ventral setae on the tarsi are not differentiated from other tarsal setae (unless they are scopulate). The thick and blunt tarsus IV macrosetae (Fig. 22F; Opell, 1979: 469, fig. 1A) occurring in deinopids and uloborids have previously been suggested as a synapomorphy for the Deinopoidea (Coddington, 1986a, 1990a, b). The curved, serrated macrosetae of theridiids and necticids (Fig. 22H) differ from the deinopoid morphology. The theridioid tarsal comb functions in the sticky silk attack on prey (see characters 73, 86 and above under ‘Theridiidae’). They are a synapomorphy for theridioids (Coddington, 1986a, 1990a, b, Forster *et al.*, 1990; Hormiga, *et al.*, 1995).

63. *Tarsus IV median claw*: (0) normal; (1) elongate.

The fourth tarsal median claw of some symphytognathoids (Fig. 22B) is longer, more slender, and more sinuate than the lateral claws (Coddington, 1986a). On this cladogram the feature is synapomorphic for the symphytognathoid families but reverses to the normal, shorter form in the anapid exemplars used here.

64. *Sustentaculum*: (0) absent; (1) present.

The sustentaculum is a thick macroseta (Fig. 22A) with a bent tip, situated ventrally behind the accessory claws of the fourth tarsi (Scharff & Coddington, 1997; Hormiga *et al.*, 1995). The macroseta was called ‘Sustentaculum’ by Reimoser (1917), and ‘Webestachel’ by Dahl (1912: 502, fig. 27). The sustentaculum optimizes here as a synapomorphy for the Araneidae.

Spinnerets

65. *Colulus*: (0) large, triangular and fleshy; (1) reduced to less than one half length of its setae.

The colulus, a homologue of the lost cribellum, is usually a fleshy, lobate structure, typically triangular to conical in Araneoidea (Figs 23B, 25A, 40A). Levi and Levi (1962: 6) recognized the importance of reduction or loss of the colulus in the classification of the Theridiidae. In the theridiid genera *Anelosimus* and *Dipoena* the colulus is reduced, and in *Euryopis* it is replaced altogether by two setae. Symphytognathids have a minute colulus (Figs 23A, 37A), less than one fifth the length of its setae, whereas in the Anapidae *Gertschanapis* (Fig. 34A) has a large colulus of plesiomorphic form. The colulus of *Anapis* was not observed and could not be scored: it is either hidden by the ring-like scutum surrounding the spinnerets or lost.

Colular reduction is derived independently for the Symphytognathidae and in *Anelosimus* plus the hadrotarsine theridiids.

66. *Cribellum*: (0) present; (1) lost.

The work of Lehtinen (1967), Forster (1970), and Baum (1972) showed that cribellate and cribellate spiders could be close relatives, and Platnick (1977) established that the cribellum was a synapomorphy for all Araneomorphae. Loss of the cribellum has occurred many times. Here loss of the cribellum is an unambiguous synapomorphy for the Araneoidea.

67. *Spinneret stridulating structure*: (0) absent; (1) present.

The classical hadrotarsids and certain theridiid genera have a series of parallel ridges on the median surfaces of the ALS that are apparently stridulatory (Forster *et al.*, 1990: 111, fig. 392). Similar structures occur only in the distantly related Malkaridae (Platnick & Forster, 1987, fig. 22), and we have observed nothing similar in our extensive survey of araneomorph spinnerets. The feature is a synapomorphy for the hadrotarsine genera *Dipoena* and *Euryopis*.

68. *ALS major ampullate gland (MAP) spigot number*: (0) many; (1) one.

All Araneioidea and Uloboridae have a single ALS MAP spigot plus an associated nubbin (Fig. 24B). The several MAP spigots observed on the mesal margin of the ALS of deinopids (Coddington, 1989, fig. 3) appear to be an autapomorphy for this family, consistent with the results in Coddington (1990b) and Platnick *et al.* (1991). Multiple ALS MAP spigots also occur elsewhere (Platnick *et al.*, 1991): in hypochilids and gradungulids (where they are segregated, as in deinopids) and in filistatids and eresids (where they are dispersed among the piriform field), but these states are independently evolved.

69. *ALS piriform gland (PI) spigot bases*: (0) normal; (1) reduced.

The PI spigot base is typically nearly as long as (Fig. 48B), or longer than, the shaft. PI spigots with bases greatly reduced or even absent so that the spigot shaft emerges directly from the spinneret surface (Figs 24B, 27B, 40B), are known to occur only in a few araneoid families.

On our cladogram this new character is a synapomorphy for the group we call the 'reduced piriform clade' that includes the symphytognathoid families, linyphioids, theridioids, and cyatholipoids (see also Hormiga, *et al.*, 1995).

70. *PMS aciniform gland (AC) spigot brush*: (0) present; (1) absent.

Coddington (1989) suggested that an extensive anterior brush of AC spigots on the PMS, such as that found in deinopoids and Araneidae (Fig. 48C), was probably a plesiomorphic feature for the Orbiculariae. In this study, we define the PMS aciniform brush as consisting of ten or more AC spigots grouped on the anterior face of the PMS.

In this study reduction of the PMS anterior AC field is a synapomorphy for the 'derived araneoids', that is, Araneioidea exclusive of Araneidae. The condition in *Meta*, which may have 14 or more AC spigots, is a reversal to the primitive condition.

71. *PMS minor ampullate gland (mAP) spigot nubbins*: (0) 0; (1) 1; (2) 2.

Coddington (1989, 1990b) inferred that the presence of a PMS mAP spigot nubbin in the adult stage was a synapomorphy for Araneioidea, though occasionally lost in derived lineages. Our more extensive evidence bears this out, but also reveals complications. Such nubbins are indeed lacking in deinopoids (and more distant outgroups) and present in more basal araneoid lineages: Araneidae, Tetragnathidae, and the symphytognathoids (Figs 24C, 31C, 33C, 48C). Loss of this nubbin (Fig. 46C) is a synapomorphy for the sheet web weavers (linyphiid-pimoids, nestacid-theridiids, and cyatholipid-synotaxids), though reversals lead to nubbins in *Nesticus* and basal synotaxids. The presence of two nubbins at the same time has also been observed in juvenile araneids (Yu and Coddington, 1990). The persistence of a second nubbin is independently derived in *Anapis* (Fig. 31C) and *Chileotaxus* (Fig. 40C).

72. *PMS mAP spigot position*: (0) median-anterior; (1) posterior.

Coddington (1990b) discovered that strictly posterior mAP spigots (Figs 24C, 37C, 46C) are typically araneoid, and considered the feature synapomorphic. Median to anterior PMS mAP spigots are widely distributed in the Araneomorphae and are the presumed groundplan state for the 'RTA clade'. If the 'RTA clade' is the sister group of the Orbiculariae, the posterior PMS mAP spigot remains synapomorphic for Araneioidea.

73. *PMS cylindrical gland (CY) spigot number*: (0) many; (1) 1; (2) 0.

Coddington (1990b) suggested that the multiple CY spigots on the PMS (Coddington, 1989, fig. 4) were synapomorphic for Deinopoidea. None of our new results from araneoids contests that suggestion.

Forster *et al.* (1990: 109) noted that some hadrotarsines and the synotaxid genus *Mangua* had the PMS spinning field reduced to only the mAP spigot, thus tentatively a synapomorphy uniting Synotaxidae and theridioids. In Figures 7 and 9, hadrotarsines emerge as a distal group within theridiids and synotaxids are sister to cyatholipids. Here loss of PMS CY spigots unites the derived synotaxids *Chileotaxus* (Fig. 40C), *Meringa* (Fig. 44C), and *Pahora* (Fig. 42C), and is an autapomorphy for the hadrotarsine *Euryopis*. Reduction of the PMS CY spigots may define lineages within hadrotarsines, but to establish this more hadrotarsine genera need be studied.

74. *PLS CY spigot number*: (0) many; (1) two; (2) one.

As with the previous character, Coddington (1990b) considered multiple CY spigots on the PLS (Coddington, 1989, fig. 9) to be a synapomorphy for the Deinopoidea.

In Araneoidea two PLS CY spigots is clearly the plesiomorphic state. Loss of the basal CY spigot in Cyatholipidae (Fig. 46D) and some Synotaxidae is derived. The optimization of basal CY spigot loss in the cyatholipid/synotaxid lineage is ambiguous: either the cyatholipids and the common ancestor of the three synotaxid genera *Chileotaxus* (Fig. 40D), *Meringa* (Fig. 44D), and *Pahora* (Fig. 42D) have lost the basal CY spigot independently, or loss of the basal CY spigot is a synapomorphy for the cyatholipid/synotaxid lineage with a regain of this spigot in *Synotaxus*. Whereas independent loss might be preferred over a loss and regain, reappearance of the second spigot cannot be ruled out. The spigot interpreted as the basal PLS CY spigot in *Synotaxus* is nearly vestigial; it is not a typical CY spigot (Fig. 38D). Conclusive evidence for the cladistic loss and regain of spigots (PMS AC) may be found in Hormiga (1994b: 16). Nevertheless, on this cladogram we prefer two losses of the basal PLS CY spigot.

75. *PLS basal CY spigot base*: (0) normal; (1) enlarged.

The PLS basal CY spigot is usually about the same size as the mesal one or that on the PMS (Fig. 24C,D), but in a few taxa it is obviously larger and longer (Figs 31D, 33D, 35D, 36D; Coddington, 1989; Hormiga, 1993, 1994a; Hormiga *et al.*, 1995). These results show three independent derivations of a basal CY spigot with an enlarged base: an autapomorphy in *Glenognatha*, a synapomorphy for Symphytognathidae plus Anapidae, and a synapomorphy for Linyphiidae plus Pimoidae. This character cannot be scored for cyatholipids and derived synotaxids because they lack the basal PLS CY spigot.

76. *PLS mesal CY spigot position*: (0) central; (1) peripheral.

In most basal orbicularians and other spiders, the PLS mesal CY spigot (which is usually anterior to the other CY spigot) arises from within the PLS aciniform spinning field (Fig. 48D; Coddington, 1989, figs 17, 21). In derived araneoids it is peripheral, being located outside the AC field (Figs 24D, 38D; Hormiga, *et al.*, 1995).

Here this character is a synapomorphy for the derived Araneoidea.

77. *PLS flagelliform gland (FL) spigot*: (0) absent; (1) present.

The FL spigot (Figs 24D, 33D, 46D) provides the dry rubbery component of the sticky silk lines of cribellate orb-weavers and their relatives (Sekiguchi, 1952; Peters, 1955).

Kovoor (1977) found that flagelliform glands occurred in all araneoid families studied and further suggested that a pair of glands in uloborids similar to araneoid flagelliform glands could be homologous (Kovoor, 1978). Coddington (1986a, 1990a, b) found cladistic support for the homology of pseudo-flagelliform and flagelliform glands and suggested that they were synapomorphies for the Orbiculariae and Araneoidea respectively.

On this cladogram the PLS FL spigot is a synapomorphy for the Araneoidea.

78. *PLS aggregate gland (AG) spigot*: (0) absent; (1) present; (2) huge.

The paired AG spigots (Figs 33D, 46D, 48D) flank the FL spigot and coat the FL fibre with sticky glue as it is spun. Aggregate glands have been observed in all araneoid families for which gland histology has been studied (Kovoor, 1977). AG spigots also are present in all araneoid exemplars included here, although they are sporadically lost in various groups (see above under 'Taxa'). Kovoor (1977) noted the presence of lobed aggregate glands in theridiids. Coddington (1989) observed that AG spigots in theridiids and to a certain extent in nesticids are enlarged and have a larger aperture than other spigots (Coddington, 1989, fig. 29). The enlarged, lobate aggregate glands (sometimes called lobate glands) and huge spigot openings facilitate the theridiid sticky silk wrap attack (see below under character 93). Forster *et al.* (1990, fig. 378) could not score the character in *Synotaxus* due to poorly preserved material. Figures 38A and D show that the diameter of *Synotaxus* AG spigots is much greater than any other spigot elsewhere on the spinnerets. We code them as 'huge' (state 2) although they are not so disproportionate as in nesticids or theridiids. Based on few observations (Coddington and Hormiga, pers. obs.), *Synotaxus* also uses a sticky silk wrap attack, although it lacks the tarsus IV silk-throwing comb of theridiids and nesticids.

Here AG spigots are a synapomorphy for the Araneoidea: huge AG spigots arise in parallel in the theridiid-nesticid lineage and in *Synotaxus*. Other synotaxids have small AG spigots.

79. *Spinneret cuticle*: (0) ridged; (1) squamate.

As noted above (character 51), the cuticle texture and setal morphology of araneoids are unique (Lehtinen, 1975). The ridged or 'fingerprint' cuticular pattern occurs widely in the Neocribellatae, but transversely broad scales (squamate pattern) is a synapomorphy for Araneoidea (Fig. 25C).

Behaviour

80. *Web*: (0) orb; (1) sheet; (2) gumfoot; (3) *Synotaxus*.

Evidence to date continues to suggest that the orb web architecture (defined by Coddington, 1986a) is plesiomorphic for Orbiculariae (Figs 1A–D, 3A–D, 4C; Coddington, 1989, 1990a). Due to lack of

study, 'sheet' webs can be only vaguely defined. Sheet webs are planar webs (the plane may be simply or complexly distorted) in which the pattern of lines making up the sheet is asymmetric, irregular, non-radial, and apparently more or less random (Fig. 5D). This is a purely architectural definition. As with orbs, study of behaviors involved in sheet web construction may provide less negative and more satisfactory discrimination. The sheet itself is often combined with other sheet-like layers, scaffolding, 'knock-down' webs, barriers, or retreats. As a rule, sheet webs also have many more guy lines (silk lines that attach to non-silk substrate) than orbs. Linyphiids (Figs 4B, 5D) and pimoids (Fig. 4A) build classic sheet webs; cyatholipids make flat, apparently double sheets that may have some scaffolding above and below the sheet (Figs 4D, 5A–C). Other than *Synotaxus* (see below), the webs of Synotaxidae are not well known. Platnick (pers. comm.) described the web of *Chileotaxus* as "built over the tips of twigs basically as a sheet with a tight but not particularly regular mesh." The web of *Meringa* has been reported to be "irregular, sheetlike" (Forster *et al.*, 1990: 6). Pahorinae spin "a distinctive snare consisting of an inverted bowl with numerous threads above the bowl" (Forster, *et al.*, 1990: 39, fig. 191). The webs of *Pahoroides* (Fig. 2E; Forster *et al.* 1990, fig. 191) do not differ in appearance significantly from those of many linyphiids: we therefore score its close relative *Pahora* as having a sheetweb. Other synotaxids build sheet and dome-shaped webs (Griswold, pers. obs. of *Runga* and *Mangua*).

The 'gumfoot' web (Fig. 2A–C) typifies the theridiid-necticid lineage. It is a simple or complexly distorted sheet to which gumfoot lines are attached. Gumfoot lines are dry silk lines whose extremities alone bear sticky silk (Fig. 2B). Usually gumfoot lines are spun at higher tension and the sticky ends attach to substrate, but exceptions occur. Three theridiid exemplars are scored non-applicable. Group-living *Anelosimus* make three-dimensional, sheetlike webs (Foelix, 1982, fig. 178; Tietjen, 1986). *Euryopis* captures prey without a pre-existing web (Carico, 1978). Though commonly collected, *Dipoena* are not known to make webs. The diversity of theridioid web architecture is still very poorly known.

The *Synotaxus* web is unique. It consists of juxtaposed vertical modules consisting of regular horizontal arrays of dry silk, themselves spanned vertically by short sticky segments (Fig. 2D; Eberhard, 1977; Coddington, 1986a, fig. 12.4).

We have no evidence to propose any special similarity between any of these web architectures, primarily because the building behaviour of non-orb weavers has been so little studied. For example, although Eberhard (1977) described *Synotaxus* building behavior in detail, the lack of descriptions for other non-orb architectures frustrated detailed comparison.

On this cladogram the orb is plesiomorphic for Araneoidea and Deinopoidea (*Deinopis* spins an orb, Coddington, 1986b). Sheets derive from orbs, and gumfoot webs and the *Synotaxus* architecture from sheets.

81. *Web posture*: (0) legs 1, 2 extended; (1) legs 1, 2 flexed.

Deinopoidea, and some tetragnathids rest on their webs with the first four legs together and extended directly in front (Hormiga *et al.*, 1995, "metine resting posture", Coddington, 1990a, b). In other orbicularians the first and second legs are usually flexed when at rest on the web. Outgroup comparison suggests that the flexed position is plesiomorphic.

On this cladogram the web posture with extended legs 1 and 2 arises independently in Deinopoidea and the metine/tetragnathine tetragnathids.

82. *Frame*: (0) two-dimensional; (1) three-dimensional.

Many orb weavers initially explore the web site by building primary radii (i.e. future guy lines) in three dimensions. After the spider chooses the plane and orientation of the web, the superfluous primary radii that will not be used to guy the web are cut away (e.g. Fig. 1C). Symphytognathoid families leave one or more primary radii extending out from the plane of the orb (Coddington, 1986a). Theridiosomatids leave one to serve as the tension line (Fig. 1D). Anapids (Fig. 3D) and *Maymena* (Fig. 3A) leave a few to anchor out-of-plane sticky silk spiral segments. *Mysmena* leaves so many that the resulting web is a three-dimensional egg-shaped structure (Fig. 3B; Eberhard, 1987a; Coddington, 1986a, 1990a).

83. *Radii*: (0) cut and reeled; (1) twice attached to frame; (2) doubled.

Eberhard (1982) described several ways in which orb weavers lay and connect radii; these behaviors are phylogenetically informative (Coddington, 1990a; Hormiga *et al.*, 1995). Nephilinae interrupt hub loop construction (itself continuous with nonsticky spiral construction) and move along a pre-existing radius to a vacant spot on the frame, paying out a new line behind. The spider attaches this radius to the frame, moves a few millimeters along the frame and attaches it again, and finally returns to the hub and attaches its dragline, thus having laid two juxtaposed but distinct radii in a single pass from hub to frame and back. This radius construction behavior is unique to nephilines (state 1; Eberhard, 1982, character F2).

Most orbicularians cut and reel radii as they are being laid. Initial steps are as in nephilines, but the radius is attached only once to the frame, and as the spider returns to the hub on the radial line just laid, this radial line is cut, reeled up, and eaten so that the dragline behind forms the only radial line. The result is only one radius for a pass from hub to frame and back (state 0; Eberhard, 1982, character F1).

Uloborids cut and reel to make frames, but omit cutting and reeling when spinning radii. However, like other non-nephiline orbicularians, they attach radii only once to the frame. The result is that uloborid radii are double; one line laid on the way out and one on the return (state 2; Eberhard, 1982, character F4).

Here 'cut and reeled' is plesiomorphic for the Orbiculariae, 'nephiline' is a synapomorphy for the Nephilinae, and 'doubled' is an autapomorphy for the uloborids.

84. *Radial anastomosis*: (0) absent; (1) present.

Eberhard (1981) described and pointed out the phylogenetic significance of anastomosis of radii (Fig. 4C) prior to insertion at the hub. The feature is a synapomorphy for the symphytognathoid families (Coddington, 1986a, 1990a). Given the plesiomorphic condition in *Epeirotypus*, Coddington (1986c) suggested that radial anastomosis in *Theridiosoma* arose independently of that in other symphytognathoids. Alternatively (and this is the optimization preferred in Fig. 9), radial anastomosis may be a symphytognathoid synapomorphy, with loss in *Epeirotypus*.

85. *Accessory radii*: (0) absent; (1) present.

In the Mysmenidae (Fig. 3A,B), Anapidae (Fig. 3D), and Symphytognathidae (Fig. 3C), after completion of the sticky spiral, the spider constructs a new set of radii that are laid beneath and against the completed orb. Unlike structural radii, the sticky spiral does not 'kink' when crossing accessory radii (Eberhard, 1981, 1987a; Coddington, 1986a, 1990a). In *Maymena* and symphytognathid webs, the accessory radii outnumber structural radii (Fig. 3A,C).

86. *Temporary non-sticky spiral*: (0) removed from finished web; (1) remains in finished web.

The dry spiral line spun from the hub outwards after (and during) radius construction, serves as a scaffolding to shorten the distance spiders must move between radii while spinning the sticky spiral. The spider usually cuts every interradial segment of this dry spiral as it makes the sticky spiral (Fig. 1C; Eberhard, 1987b). In adult Nephilinae (and independently in the cyrtophorine araneids) the temporary spiral is not removed and persists in the finished web (Fig. 1A,B; Hormiga *et al.*, 1995). Hormiga *et al.* (1995) suggest that the retention of the temporary spiral might serve to strengthen the web. This character serves as a synapomorphy for the Nephilinae.

87. *Sticky silk spiral (SS) localization*: (0) oL1; (1) iL1; (2) oL4.

Eberhard (1982) first pointed out the phylogenetic significance of the different legs used by orb weavers to locate themselves during sticky spiral construction, and systematists have emphasized it ever since (e.g. Coddington, 1986a, 1990a; Hormiga *et al.*, 1995).

Araneids and uloborids use the outside first leg (away from the hub, hence 'oL1') to touch the previous sticky spiral before attaching the current segment. Derived araneoids use the inside first leg (towards the hub, hence 'iL1'). Nephilines use the outer fourth leg (hence 'oL4') to perform the same task.

Localization with oL1 is plesiomorphic for the Orbiculariae; iL1 localization is a synapomorphy for derived araneoids, and oL4 localization is a synapomorphy for nephilines.

88. *Post-SS hub loops*: (0) absent; (1) present.

After the sticky spiral is completed, members of the Theridiosomatidae, Mysmenidae, Anapidae, and Symphytognathidae, simultaneously destroy the old and spin a new hub (Eberhard, 1987a; Coddington, 1986a, 1990a).

On this cladogram this is a synapomorphy for the symphytognathoid families.

89. *Hub bite-out*: (0) absent; (1) present.

This character refers to the removal of the centre but not the periphery of the hub after sticky spiral construction is completed. Uloborids and nephilines leave the hub of the web intact (Fig. 1B; Eberhard, 1982; Hormiga *et al.*, 1995). Other orb weavers modify the hub. In the araneids and tetragnathids only the hub centre may be bitten out (Eberhard, 1982, characters G2, G3); in the symphytognathoids the entire hub is destroyed (Eberhard, 1982, character G4).

Hub bite-out is a synapomorphy for the Araneoidea, with reversion to persistence of the hub evolving independently in the Nephilinae and in *Glenognatha*.

90. *Hub*: (0) closed; (1) open.

Subsequent to hub bite-out, some orbweavers fill in the resulting hole and others leave it open, resulting in either an open or closed hub.

An open hub is a synapomorphy for *Meta*, *Leucauge*, and the tetragnathines (see also Hormiga *et al.*, 1995).

91. *Eggsac doubly attached*: (0) absent; (1) present.

Basal theridiosomatid genera such as *Ogulinus*, *Plato*, *Naatlo*, *Epeirotypus*, the anapids *Anapis*, *Anapisona*, and the mysmenids *Mysmena* and *Maymena* retain their eggsacs at or near the hub of their webs (Coddington, 1990a, character 84). The eggsacs are attached by two silk lines within the web or with one line attaching to the substrate. There are no field observations on symphytognathid eggsacs. No other araneoids are known to behave in the same way.

Here this feature is a synapomorphy for the symphytognathoid families.

92. *Wrap-bite attack*: (0) present; (1) absent.

Robinson (1969, 1975) emphasized that some orb weavers wrap prey before biting, while others always bite first. Eberhard (1982) discussed the character in detail, but decided the wrap-bite complements in araneoids and uloborids were convergent. When cladistic analysis suggested that these taxa were adjacent on the cladogram, Coddington (1986a, 1990a) suggested that their behaviour might be homologous.

Results here corroborate that hypothesis. Wrap-bite attack is an orbicularian synapomorphy lost independently in *Tetragnatha*, the nephilines, the symphytognathoids, and linyphoids. In theridioids and at least *Synotaxus* wrap-bite is modified with the addition of sticky silk (see character 93).

93. *theridiid sticky silk wrap attack*: (0) absent; (1) present.

As mentioned above, theridiids and nesticids have modified the primitive orbicularian wrap-attack by using their fourth tarsal combs to fling blobs of sticky silk on prey to entangle and immobilize them (Fig. 6; Coddington, 1990a). *Synotaxus* uses a substantially similar behavior (JC and GH, pers. obs.). Forster *et al.* (1990: 109) suggested that this type of wrap attack might relate synotaxids to the theridiid-nesticid lineage, and here the character optimizes as a synapomorphy for the theridiid/nesticid and cyatholipid/synotaxid lineages (clade 10). This behavior has not been observed in cyatholipids or other synotaxids (in fact, the prey capture behaviour of these taxa remains unknown), and neither cyatholipids nor other synotaxids have a tarsus IV comb or enlarged AG spigots.

FEMALE GENITALIA, 3 characters		DUMATGLMNNQPAGMMTELPDEASNITSCMP											
		L	CI	RI	WT	1	2	3	4	5			
24. Fem gen: entelegyne; haplogyne;		2	50	66	3	-	24	-	41	25			
25. Spermathecae: sep; connate;		1	100	100	10	-	-	-	-	-			
26. Spermathecae: 2; 4;		2	50	50	2	-	-	-	-	-			
FEMALE GENITALIA, average:		1.7	67	72	5								
CEPHALOTHORAX, 18 characters		DUMATGLMNNQPAGMMTELPDEASNITSCMP											
		L	CI	RI	WT	1	2	3	4	5			
27. AME: pres; reduced or abs;		1	100	100	10	-	57	-	-	-			
28. PME tapetum: pres; abs;		2	50	66	3	-	58	32	4	51			
29. PME tapetum: normal; narrow;		1	100	100	10	-	59	-	-	52			
30. MM lateral eyes: separate; touching;		1	100	100	10	-	61	45	-	-			
31. Clypeus: < AME diam; > AME diam;		2	50	50	2	-	-	46	6	61			
32. MM size: >=0.5FF; <=0.3FF;		2	50	50	2	-	-	-	14	61			
33. MM v FF chel: same; lg'r; sml'r;		3	33	33	1	-	-	-	15	-			
34. Fangs: normal; hadrotars elongate;		1	100	100	10	-	-	-	-	-			
35. Paturon: normal; short;		1	100	100	10	-	-	-	-	-			
36. Chel teeth orig: dstnct; common base;		1	100	100	10	-	-	-	-	-			
37. Ectal M chel: smooth; strid;		1	100	100	10	-	-	-	2	-			
38. Chelicerae: free; fused;		1	100	100	10	-	-	-	-	-			
39. Cheliceral boss striae: abs; pres;		1	100	100	10	56	-	-	17	-			
40. Labrum: simple; with spur;		1	100	100	10	61	-	-	-	-			
41. Labium: l>w; l<w;		1	100	100	10	-	-	-	-	-			
42. Sternal pits: abs; pres;		3	33	33	1	-	33	38	-	-			
43. Sternum post apex: pnted; truncate;		1	100	100	10	-	-	-	-	-			
44. Caudal gut caeca: abs; prs;		5	20	71	1	-	-	-	-	-			
CEPHALOTHORAX, average:		1.6	80	84	7								
ABDOMEN/LEGS, 20 characters		DUMATGLMNNQPAGMMTELPDEASNITSCMP											
		L	CI	RI	WT	1	2	3	4	5			
45. Car-abd stridulation: abs; prs;		1	100	100	10	-	2	-	-	-			
46. Deinopoid abd. tubercles: abs; pres;		1	100	100	10	-	48	-	-	-			
47. Dorsal scutum on MM abd: abs; pres;		2	50	66	3	-	-	-	1	-			
48. Book lungs: pres; modified;		2	50	75	3	-	-	-	-	-			

APPENDIX 2—continued

		L	CI	RI	WT	1	2	3	4	5
ABDOMEN/LEGS, 20 characters	DUMATGLMNPAGMTELPOEASNI TSCMP									
49. Booklung cover: smooth; grooved;	eltgelepgdpesapiipulteskyhgh	4	25	50	1	-	-	-	12	5
50. Post trach spiracle: narrow; broad;	10110001100000000000001000000	1	100	100	10	-	-	-	-	64
51. Setae: plumose; serr;	0000000000000000000000000000000	1	100	100	10	28	-	-	-	-
52. FF palp: normal; reduced to abs;	00111111111111111111111111111111	1	100	100	10	-	49	44	-	-
53. FF palp claw: prs; abs;	0000000000--1-11100000000000000	2	50	83	4	-	51	-	-	-
54. FF palp claw: attenuate; palmate;	0000000000-----0011000--0000	1	100	100	10	-	-	-	-	-
55. Femora basally thickened: no; yes;	0000000000000000000000000000000	2	50	66	3	-	-	-	-	-
56. Femoral scler spot: abs; prs;	0000000000000110000000000000000	1	100	100	10	60	-	-	-	-
57. Mt I clasping spine: abs; prs;	0000000000000110000000000000000	1	100	100	10	59	-	-	-	-
58. Femur IV trich: abs; prs;	0100110000000000000000000000000	2	50	66	3	-	37	-	6	35
59. Fem macrosetae: pres; abs;	000001000011110000011111111111	4	25	76	1	-	-	-	-	36
60. Patella-tibia autospasy: abs; pres;	0000000000000000011000000000000	1	100	100	10	-	-	-	8	-
61. Tb IV dors trich: norm; >3x tb dia;	0000000000000000011000000000000	1	100	100	10	-	-	-	-	-
62. T IV: Deino comb; normal; THO comb;	00111111111111111111111111111111	2	100	100	10	14,32	38,39	40,41	10	-
63. T IV median claw: norm; elongate;	0000000001100111000000000000000	2	50	80	4	40	-	-	-	-
64. Sustentaculum: abs; pres;	0011000000000000000000000000000	1	100	100	10	-	-	-	9	40
ABDOMEN/LEGS, average:		1.6	77	88	7	-	-	-	-	-
SPINNERETS, 15 characters	DUMATGLMNPAGMTELPOEASNI TSCMP									
65. Colulus: triangular fleshy; 2 setae;	eltgelepgdpesapiipulteskyhgh	L	CI	RI	WT	1	2	3	4	5
66. Cribellum: pres; lost;	--00000001?0000001100000000	2	50	75	3	-	-	-	-	-
67. Spinneret strid structure: abs; prs;	00111111111111111111111111111111	1	100	100	10	-	-	-	-	-
68. ALS MAP #: many; 1;	0000000000000000001000000000	1	100	100	10	-	-	1	-	-
69. ALS PY bases: normal; reduced;	01111111111111111111111111111111	1	100	100	10	-	-	-	54	69
70. PMS AC brush(>10): pres; abs;	000011011111111111111111111111	2	50	75	3	-	-	5	56	73
71. PMS MAP nubbins: 0; 1; 2;	001111111111111111111111111111	6	33	66	2	-	-	7	-	-
72. PMS MAP position: med-ant; post;	0011111111111111111111111111-1	1	100	100	10	-	-	9	-	-
73. PMS CY #: many; 1; 0;	0011111111111111111111111111222	3	66	80	5	-	-	11	-	-
74. PLS CY #: many; 2; 1;	0011111111111111111111111111222	3	66	80	5	-	-	16	-	-
75. PLS post CY base: normal; enlarged;	000001000011100001100000--0---	3	33	66	2	-	-	-	57	-
76. PLS mesal CY pos: central; peripheral;	?000111111111111111111111111111	1	100	100	10	-	-	-	58	-
77. PLS flagelliform spigot: abs; pres;	00111111111111111111111111111111	1	100	100	10	-	-	-	-	-
78. PLS aggregate spig: abs; pres; huge;	00111111111111111111111111111111	3	66	83	5	-	47	14	-	-
79. Spin cuticle: rdgd; sqmt;	00111111111111111111111111111111	1	100	100	10	-	-	-	-	-
SPINNERETS, average:		2	78	88	7	-	-	-	-	-

APPENDIX 2—continued

	DUMATGLMNNQPAGMTELPDEASNITSCMP	L	CI	RI	WT	1	2	3	4	5
BEHAVIOR, 14 characters	eltgelespgdapesaspiipulteskygh	3	100	100	10	-	-	-	-	-
80. Web: orb; sheet; gumfoot; syno;	000000000000000011---22113111	2	50	80	4	-	87	87	42	82
81. Web posture: L12 extrnd; L12 flexed;	0011000011?1111111111111111?1	1	100	100	10	-	66,76	-	-	-
82. Frame: 2D; 3D;	000000000111111111111111111111	2	100	100	10	-	69	-	48,49	-
83. Radii: cut and reeled; neph; doubl;	020000011?00?0000-----	2	50	83	4	55	70	-	-	-
84. Radii lengthened: abs; pres;	00000?000011111110-----	1	100	100	10	-	72	-	-	-
85. Accessory radii: abs; pres;	0000000011111100-----	1	100	100	10	-	-	-	50	77
86. NS spiral: removed; remains;	00000001100000000-----	2	100	100	10	-	-	-	52	78
87. SS localization: oL1; iL1; oL4;	000111221111111111111111111111	1	100	100	10	10,30,3978	-	-	-	-
88. Post-SS hub loops: abs; pres;	0000?00001111111111111111111111	1	100	100	10	49	76	-	-	-
89. Hub bite-out: abs; pres;	00110100111111111111111111111111	3	33	50	1	-	-	-	45	-
90. Hub: closed; open;	--001-11--00000000-----	1	100	100	10	-	-	-	46	-
91. Eggsac doubly attached: abs; pres;	0000?0000?11111000?000000?00	1	100	100	10	-	84	-	-	-
92. Wrap-bite attack: pres; abs;	0001?001111111111111110000?0???	4	25	72	1	44	85	-	-	-
93. Theridiid SS wrap attack: abs; pres;	0000?00--?--?-----?11111?1???	1	100	100	10	-	79	-	-	-
BEHAVIOR, average:		1.8	83	92	8					

APPENDIX 3

Taxa examined to provide exemplar data

ANAPIDAE

Anapis sp., ♂ ♀: Bolivia, Departamento Beni, Rio Tigre, 16.8 mi. SW Yucumo, xi.1989, J. Coddington, C. Griswold, S. Larcher, and D. Silva, (USNM)

Anapis heredia Platnick and Shadab, ♂ ♀: Costa Rica, Heredia Prov., Finca La Selva, ix.1981, C. Griswold (CAS)

Gertschanapis shantzi (Gertsch), ♂ ♀: USA, California, Monterey Co., Big Creek, vi.1988, S. McDougall (CAS)

ARANEIDAE

Argiope argentata (Fabricius), ♂ ♀: Colombia, Palmira, vi.1964, R. Hunter (CAS)

Metepeira sp., ♂ ♀: Mexico, Guanajuato, ix.1976, C. Griswold and R. Jackson (CAS)

CYATHOLIPIDAE

Genus, sp. nr. *Isicabu*, ♂ ♀: Cameroon, Mt. Cameroon, Mann's Spring, i.1992, C. Griswold, J. Coddington, and G. Hormiga (CAS, USNM)

Tekella absidata Urquhart, ♂ ♀: New Zealand, Canterbury, Peel Forest, near Geraldine, v.1987, R. Forster (CAS)

DEINOPIIDAE

Deinopis spinosus Marx, ♂ ♀: USA, Florida, Gainesville, vii.1994, C. Griswold (CAS)

LINYPHIIDAE

Linyphia triangularis (Clerck), ♂: Denmark, Zealand, Dyrehaven, viii.1992, N. Scharff (CAS)

Linyphia sp., ♂ ♀: Poland, Turew, v.1974, W. Peck (CAS)

MYSMENIDAE

Maymena ambita (Barrows), ♂: USA, Arkansas, Bradley Co., Sumpter, iv–v.1964, Leslie (CAS), ♀: USA, Missouri, Rolla, vii.1951, H. Exline-Frizzell (CAS)

Mysmena (?) sp., ♂ ♀: Australia, Queensland, Kuranda, vii.1992, C. Griswold, J. Coddington, and G. Hormiga (CAS, USNM)

NESTICIDAE

Nesticus silvestrii Fage, ♂ ♀: USA, CA, Kings Canyon, viii.1984, D. Ubick (CAS)

PIMOIDAE

Pimoida breviata Chamberlin and Ivie, ♂ ♀: USA, CA, 1–1.5 mi E Bridgeville, off Rt 36, vii.1990, G. Hormiga (USNM).

SYMPHYTOGNATHIDAE

Patu digua Forster and Platnick, ♂ ♀: Colombia, Riseralda, Pueblo Rico, Santa Cecilia, Vereda La Granja, x.1991, J. Coddington (CAS, USNM)

Patu (?) sp., ♀: Australia, Queensland, Kuranda, vii.1992, C. Griswold, J. Coddington, and G. Hormiga (CAS, USNM)

SYNOTAXIDAE

Chileotaxus sans Platnick, ♂ ♀: Chile, 8 mi. W. Puerto Varas, i.1951, E. Ross and A. Michelbacher (CAS)

Meringa otago Forster, ♂ ♀: New Zealand, Otago, Opoho Bush, Dunedin, iii.1971, C. L. Wilton (CAS)

- Pahora murihiku* Forster, ♂ ♀: New Zealand, Otago, Kaka Point Preserve, iii.1988, R. Forster (CAS)
Synotaxus sp. 1, ♂ ♀: Costa Rica, Heredia Prov., Finca La Selva, ix.1981, C. Griswold (CAS)
Synotaxus sp. 2, ♂ ♀: Peru, Pakitza, D. Silva (CAS)

TETRAGNATHIDAE

- Glenognatha foxi* (McCook), ♂ ♀: USA, Arkansas, Crawford Co., vii.1968, J. Stewart (CAS)
Leucauge venusta (Walckenaer), ♂ ♀: USA, Missouri, Rolla, v.1951, H. Exline-Frizzell (CAS)
Meta menardii (Latreille), ♂ ♀: USA, Illinois, Union Co., Ava Cave, v.1965, R. Altig (CAS)
Nephila clavipes ♂ ♀: Mexico, Jalisco, 22 mi S Puerto Vallarta, x.1971, C. Mullinex (CAS)
Nephilengys cruentata (Fabricius), ♀: Brazil, Paineras, Rio de Janeiro, iii.1964, E. Ross (CAS)
Nephilengys sp., ♂: Angola, Villa Salazar, ix.1949, B. Malkin (CAS)
Tetragnatha extensa (Linneus), ♂ ♀: USA, Washington, Mt. Rainier, vii.1938, Hatch (CAS).

THERIDIIDAE

- Anelosimus studiosus* (Hentz), ♂ ♀: Ecuador, Ambato, vi.1943, H. Exline-Frizzell (CAS)
Dipoena nigra (Emerton), ♂ ♀: USA, Oregon, Emigrant Hill State Park, v.1938, Hatch (CAS)
Euryopis funebris (Hentz), ♂: USA, Missouri, Warrensburg, vi.1963, W. Peck (CAS), ♀: USA, Missouri, Newtonia, xi.1961, W. Peck (CAS)
Steatoda grossa (C. L. Koch), ♂: USA, California, San Francisco, x.1977, J. Schonewald (CAS); ♀: USA, California, Moss Beach, x.1971, J. Nuttall (CAS)

THERIDIOSOMATIDAE

- Epeirotypus chavarría* Coddington, ♂ ♀: Costa Rica, Heredia Prov., Finca La Selva, ix.1981, C. Griswold (CAS)
Theridiosoma radiosum (McCook), ♂ ♀: USA, Alabama, Coosa Co., Hatchet Creek, vi.1940, A. Archer (CAS)

ULOBORIDAE

- Uloborus* sp., ♂: USA, California, Napa Co., Howell Mt., iv.1973, H. B. Leech (CAS), ♀: USA, California, Shasta Co., Redding, viii.1947, H. Chandler (CAS)

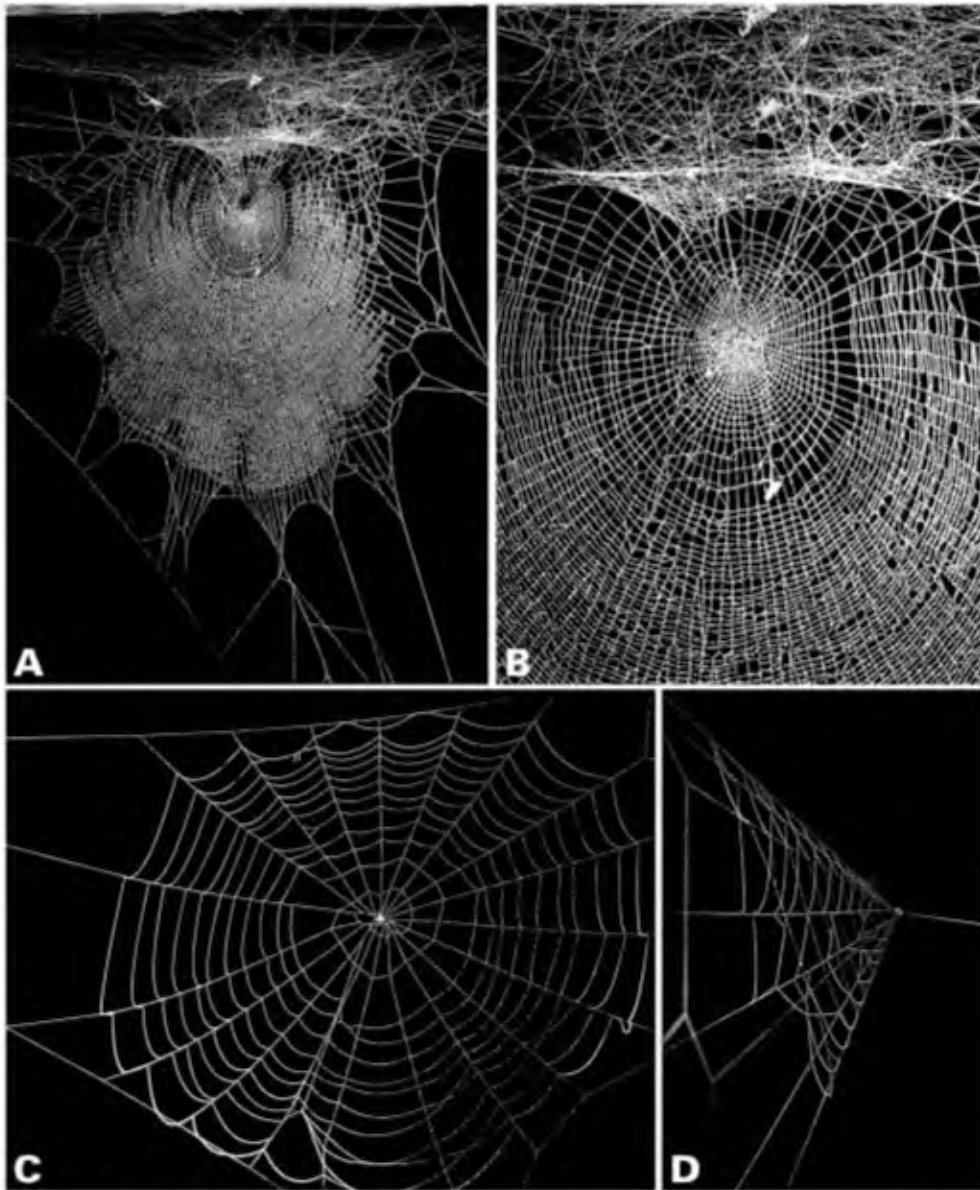

Figure 1. Webs of Araneoidea. A, *Nephila clavipes* (Tetragnathidae), La Selva, Costa Rica (JC). B, Ditto, close-of hub and retreat (JC). C, *Bertrana laselva* (Araneidae), La Selva, Costa Rica (GH). D, *Theridiosoma* sp. (Theridiosomatidae), Puerto Rico (JC).

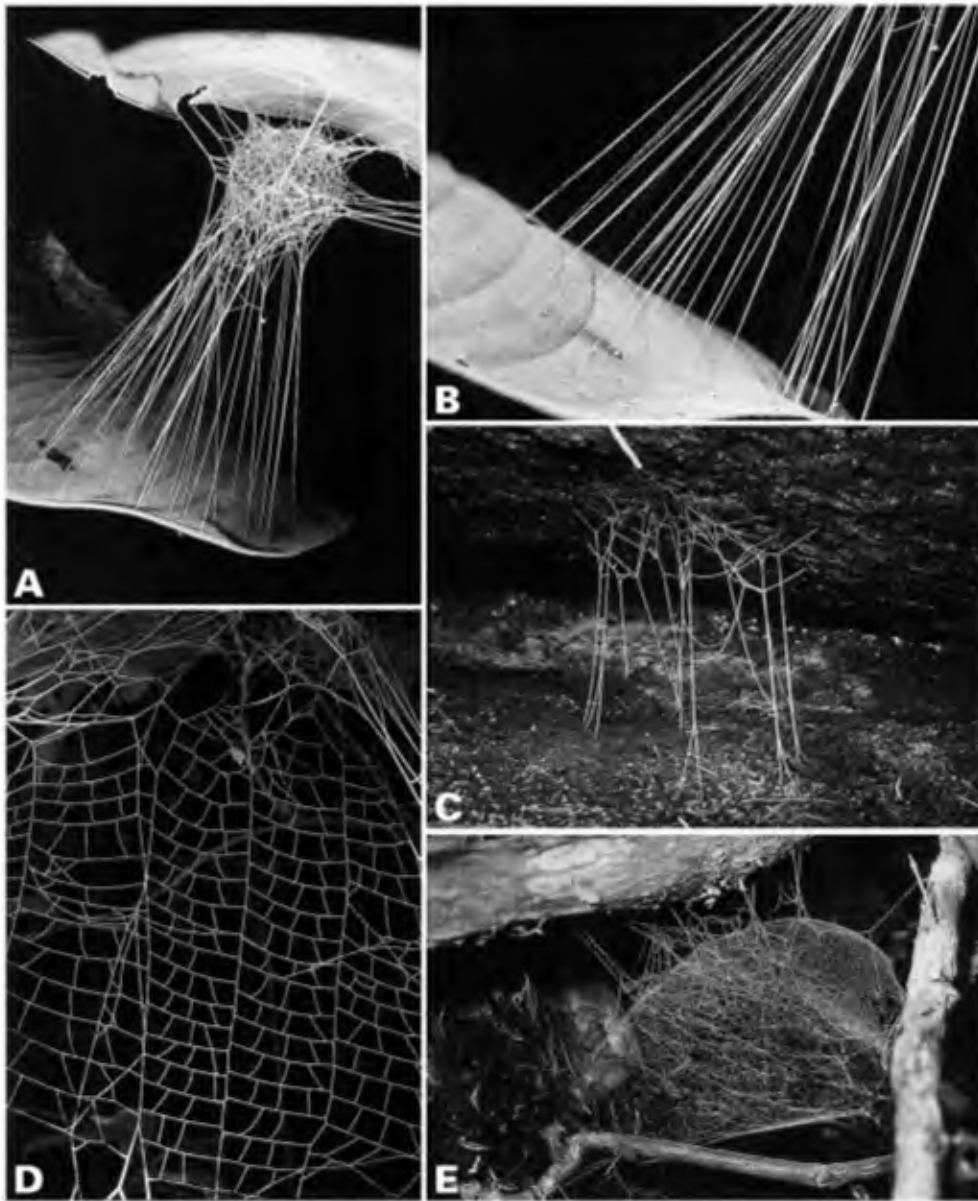

Figure 2. Webs of Araneidae. A, *Achaearanea* sp. (Theridiidae), La Selva, Costa Rica (GH). B, ditto, close-up of sticky gum-foot strands (GH). C, *Nesticus* sp. (Nesticidae), Highlands, North Carolina, USA (GH). D, *Synotaxus turbinatus* (Synotaxidae), La Selva, Costa Rica, capture lines and retreat (GH). E, *Pahoroides whangarei* (Synotaxidae), Waipoua, New Zealand (TM).

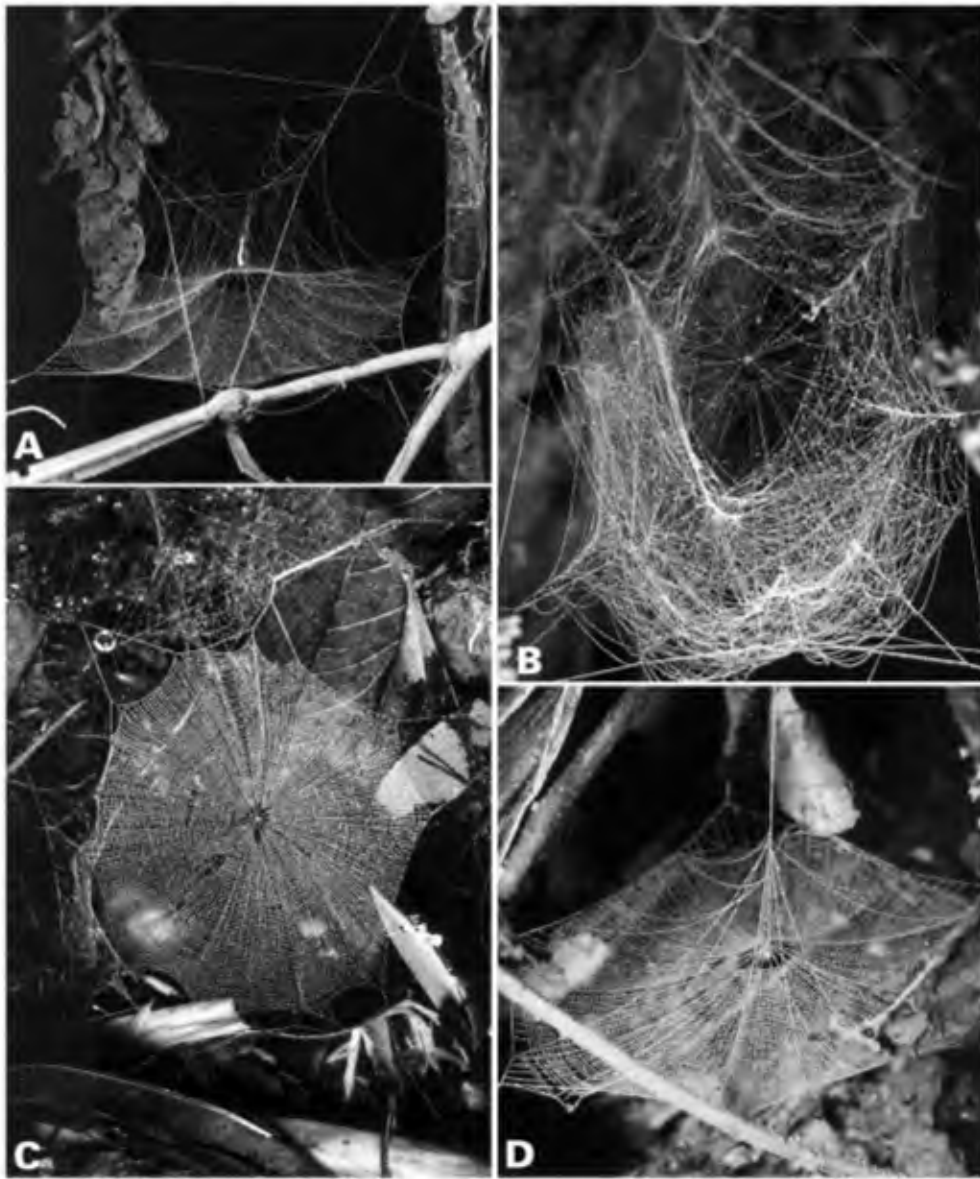

Figure 3. Webs of Araneioidea. A, *Myymena* sp. (Mysmenidae), La Selva, Costa Rica (JC). B, *Mysmena* sp. (Mysmenidae), Cerro, Costa Rica (JC). C, *Anapistula* sp. (Symphytognathidae), Ynnque, Puerto Rico (JC). D, *Anapisona simoni* (Anapidae), Llorona, Costa Rica (JC).

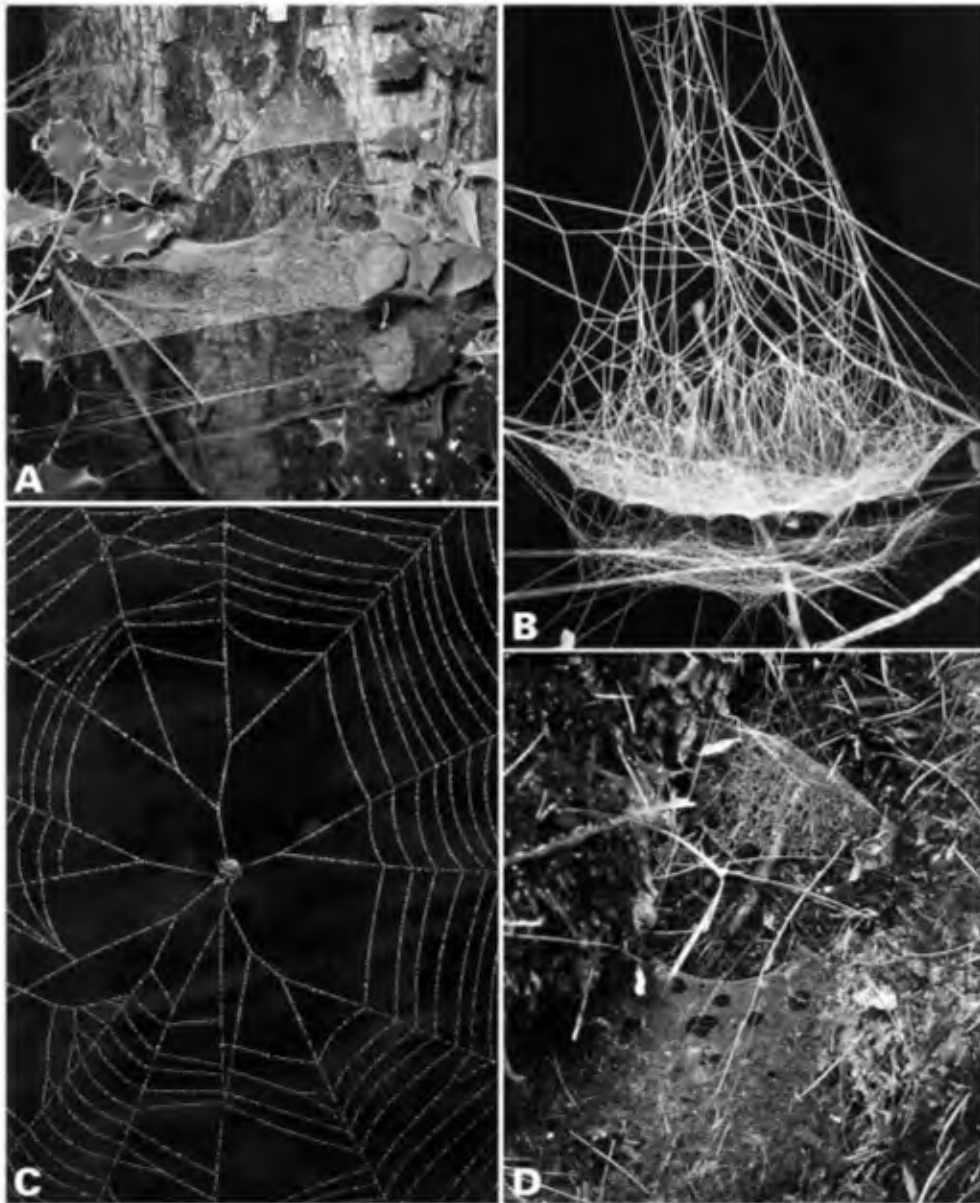

Figure 4. Webs of Araneioidea. A, *Pimoa breviata* (Pimoidae), Brookings, Oregon, USA (GH). B, *Frontinella pyramitela* (Linyphiidae), Patuxent, Maryland, USA (GH). C, *Epiloneutes globosus* (Theridiosomatidae), Barro Colorado Island, Panama (JC). D, *Tekella unisetosa* (Cyatholipidae), Fiordland, New Zealand (TM).

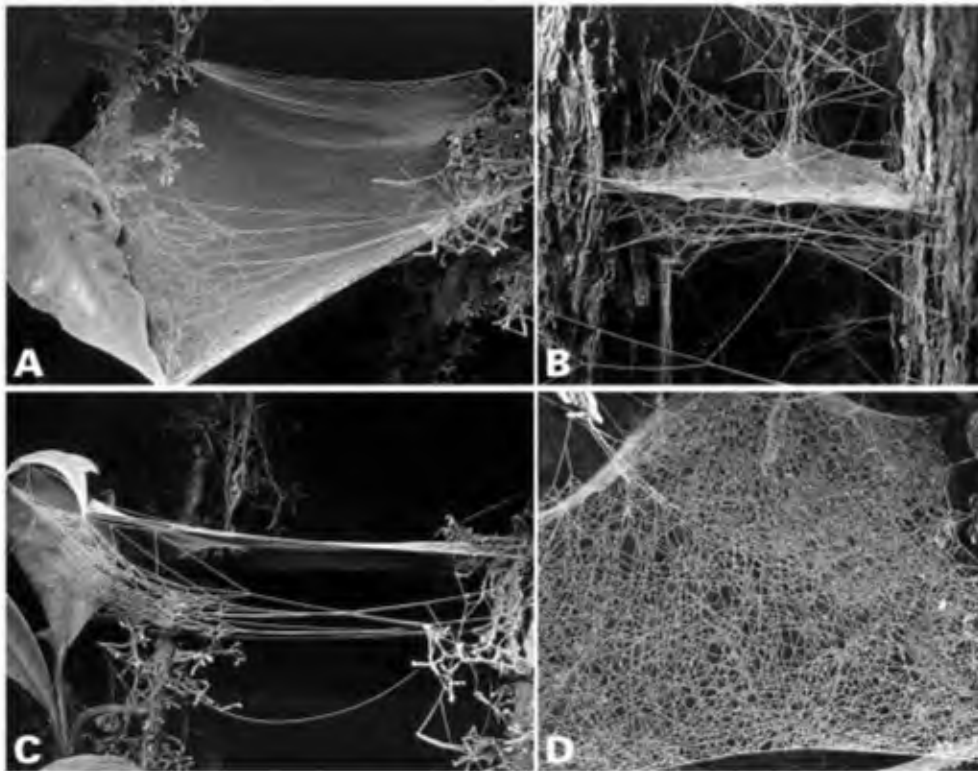

Figure 5. Webs of Araneioidea. A–C, Cyatholipidae, D, Linyphiidae. A,C *Isicabu* sp. Mt. Cameroon, Cameroon (GH). B, *Teemenaarus* sp., Kuranda, Anstralia (GH). D, *Frontinella pyramitela*, Patuxent, Maryland, USA (GH) mesh.



Figure 6. Theridiid sticky-silk wrap attack. *Achaearanea* attacks cricket (CC).

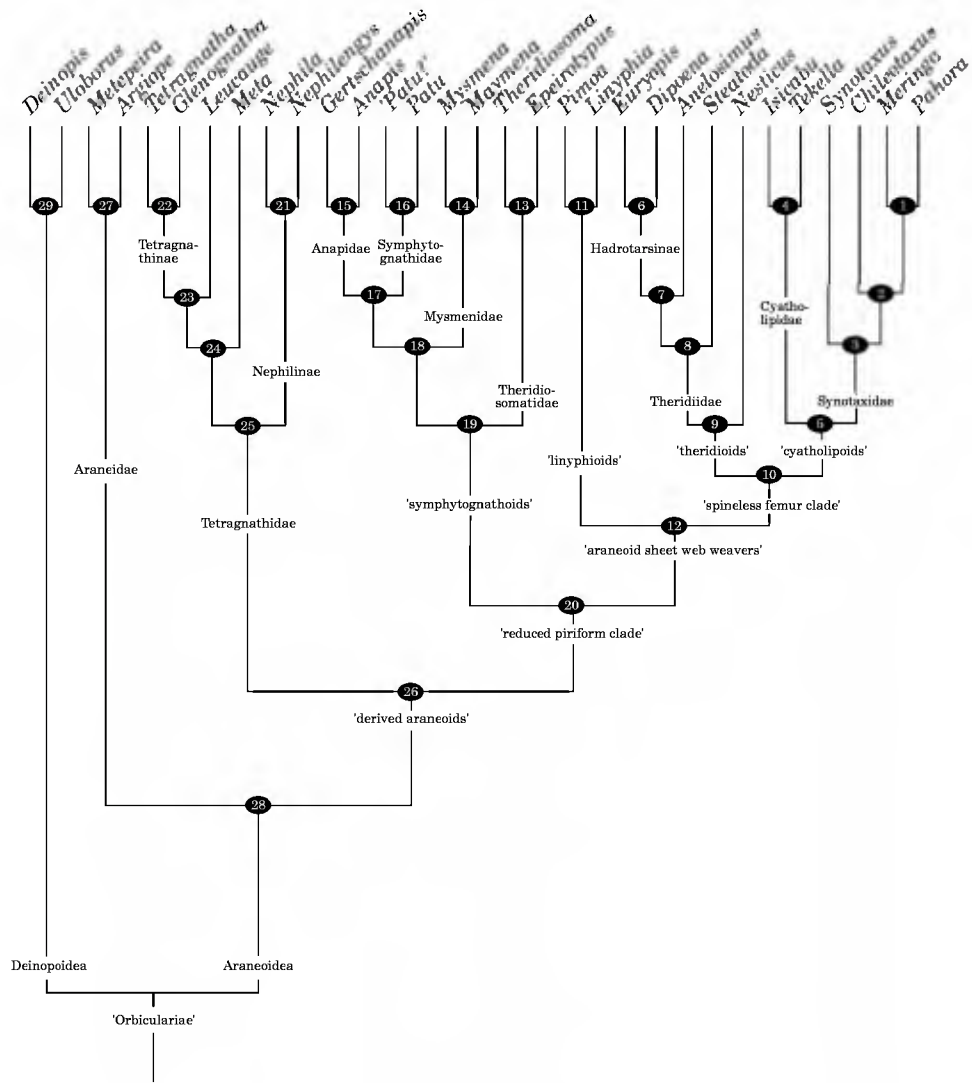

Figure 7. Cladogram for Orbiculariae, with exemplars, clade names, and numbers.

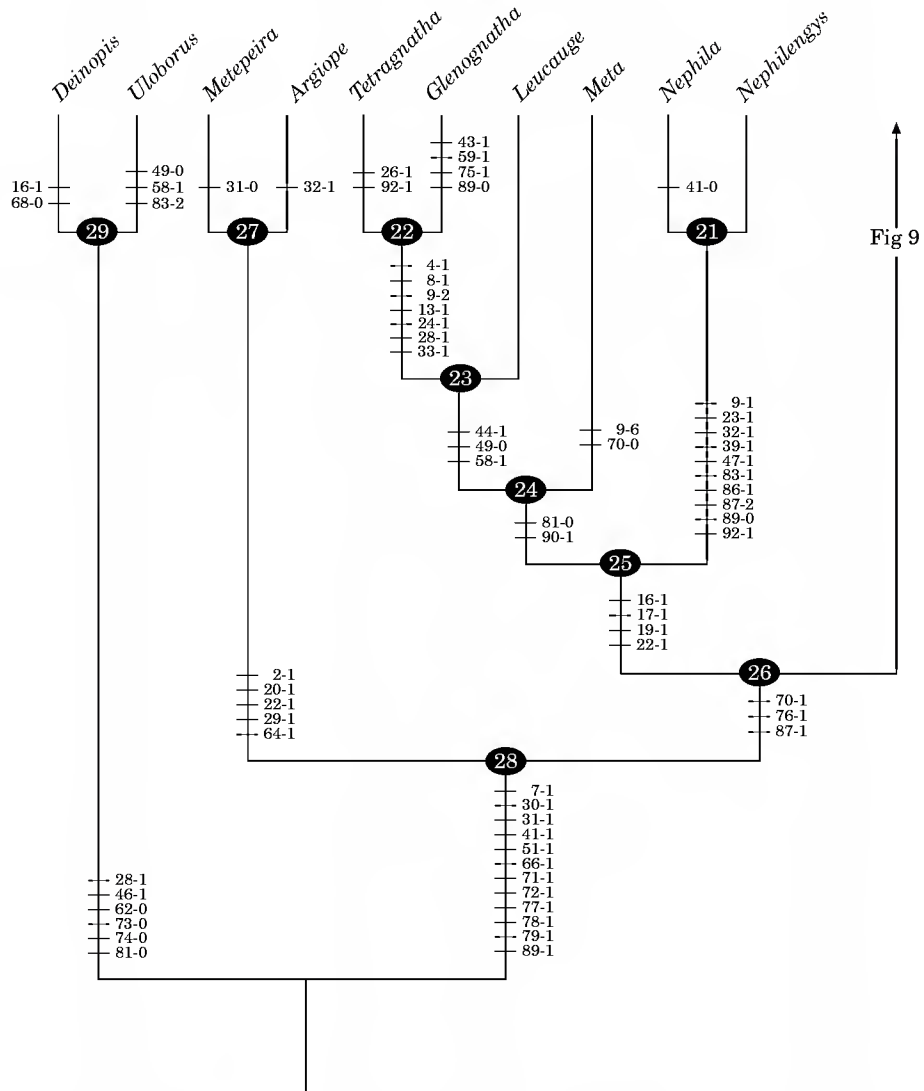

Figure 8. Cladogram for exemplars of Deinopoidea, Araneidae, and Tetragnathidae. Tick marks note character numbers and state evolving on that branch.

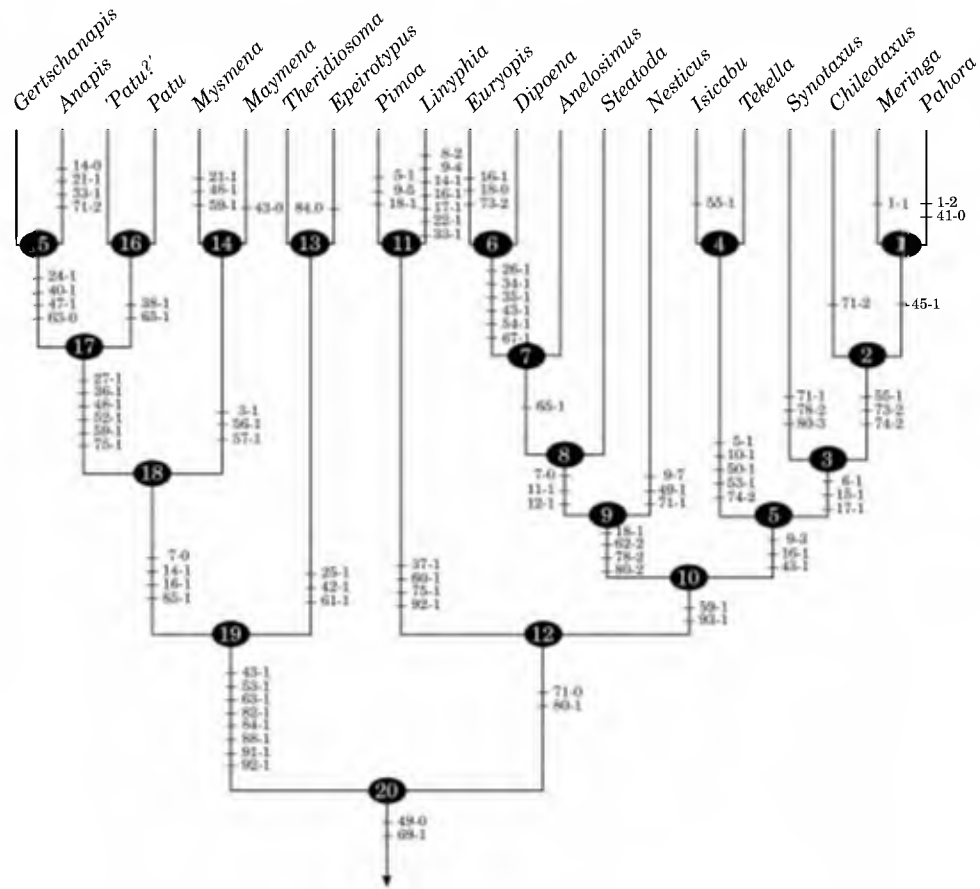

Figure 9. Cladogram for exemplars of Anapidae, Symphytognathidae, Mysmenidae, Theridiosomatidae, Pimoidae, Linyphiidae, Theridiidae, Nesticidae, Cyatholipidae, and Synotaxidae. Tick marks note character numbers and state evolving on that branch.

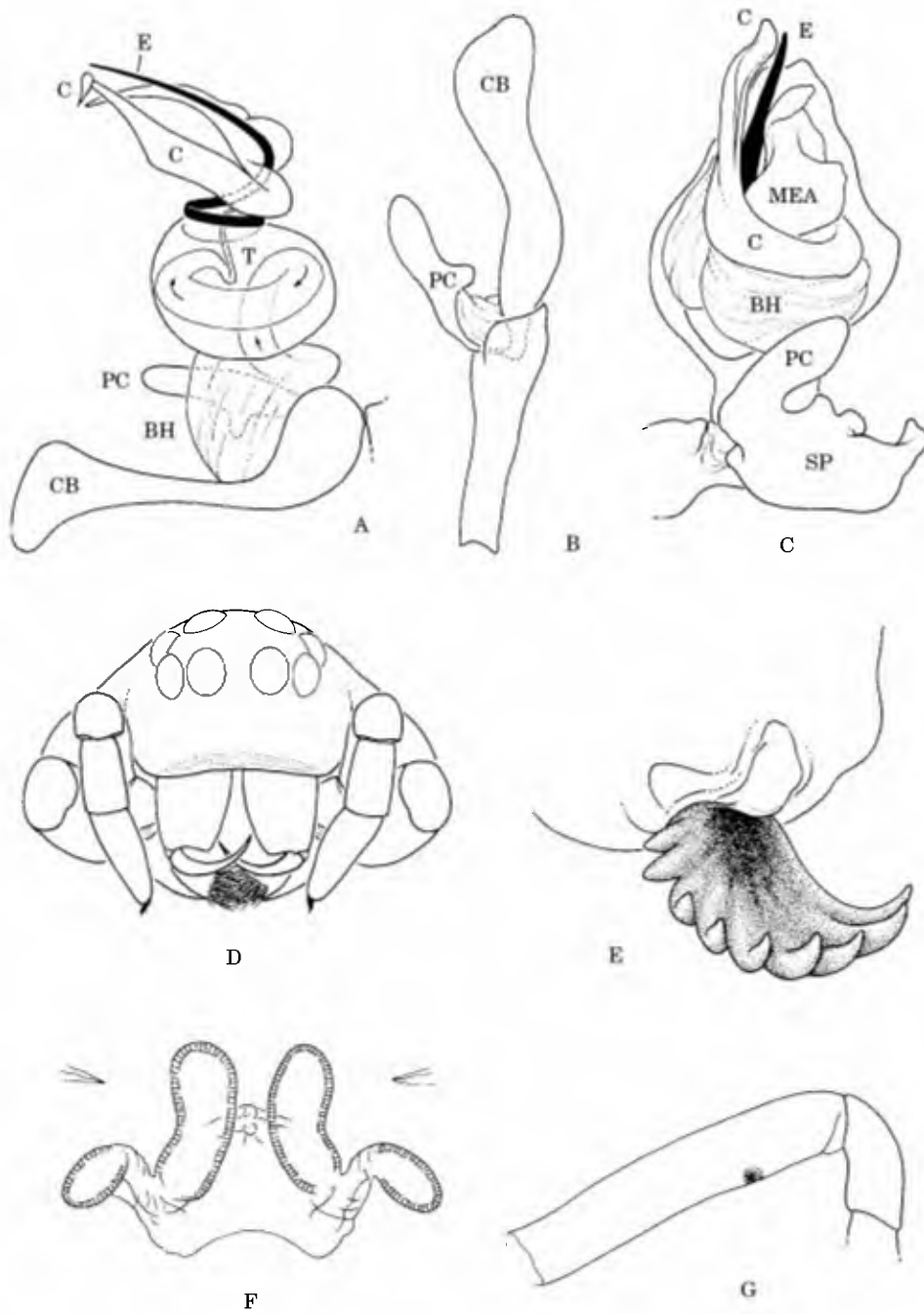

Figure 10. A, *Tetragnatha laboriosa*, expanded palp (after Levi, 1981, fig. 20). B, *Tetragnatha versicolor*, cymbium and paracymbium. C, *Meta americana*, palp, ventral. D, *Euryopsis* sp., Canberra, Australia, frontal view. E, ditto, female palpal claw. F, *Tetragnatha* sp., vulva, dorsal. G, *Mysmena leucoplagiata*, female Femur-Patella I (after Kraus, 1955). Abbreviations on p. 3.

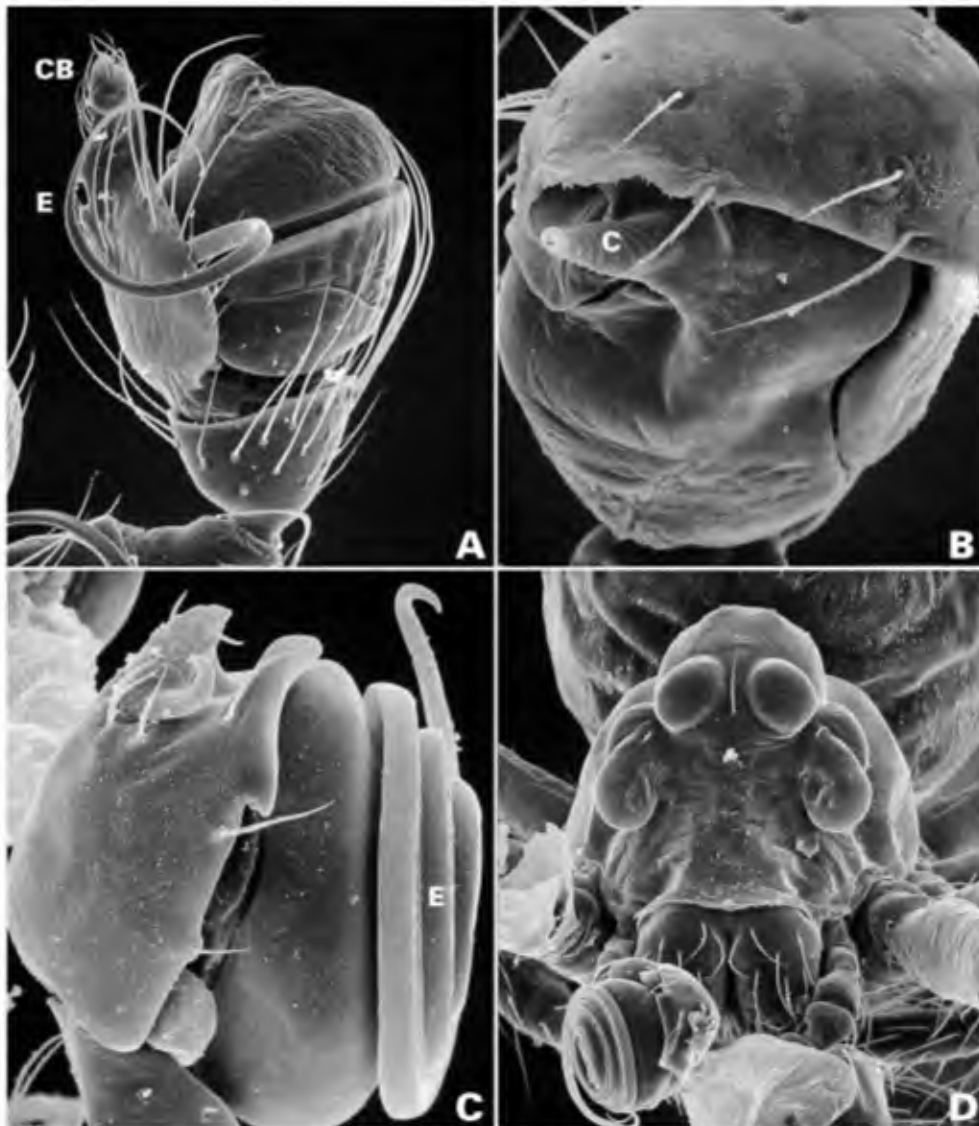

Figure 11. A, *Mysmena* sp., Cape Tribulation, Australia, right male palp, retrolateral. B, *Anapís* sp., Rio Tigre, Bolivia, right male palp, apical. C, *Patu digua*, Colombia, right male palp, retrolateral. D, ditto, carapace, anterior.

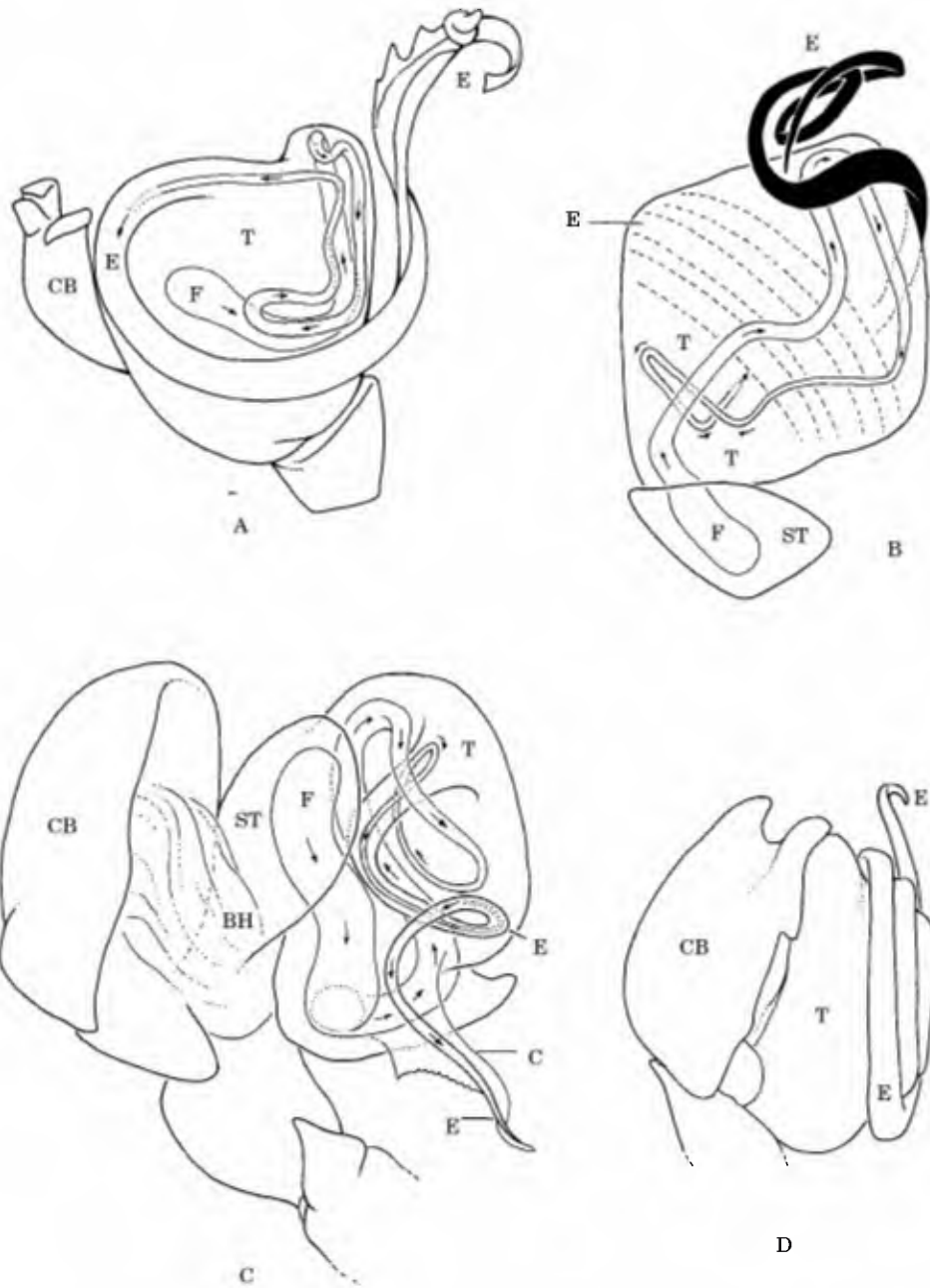

Figure 12. Right male palpi. A, *Maqmena ambita*, Sumpter, Arkansas, USA, ventral. B, *Mysmena* (?) sp., Kuranda, Australia, prolateral (cymbium removed). C, *Anapis* sp., Rio Tigre, Bolivia, expanded. D, *Patu digua*, Colombia, retrolateral.

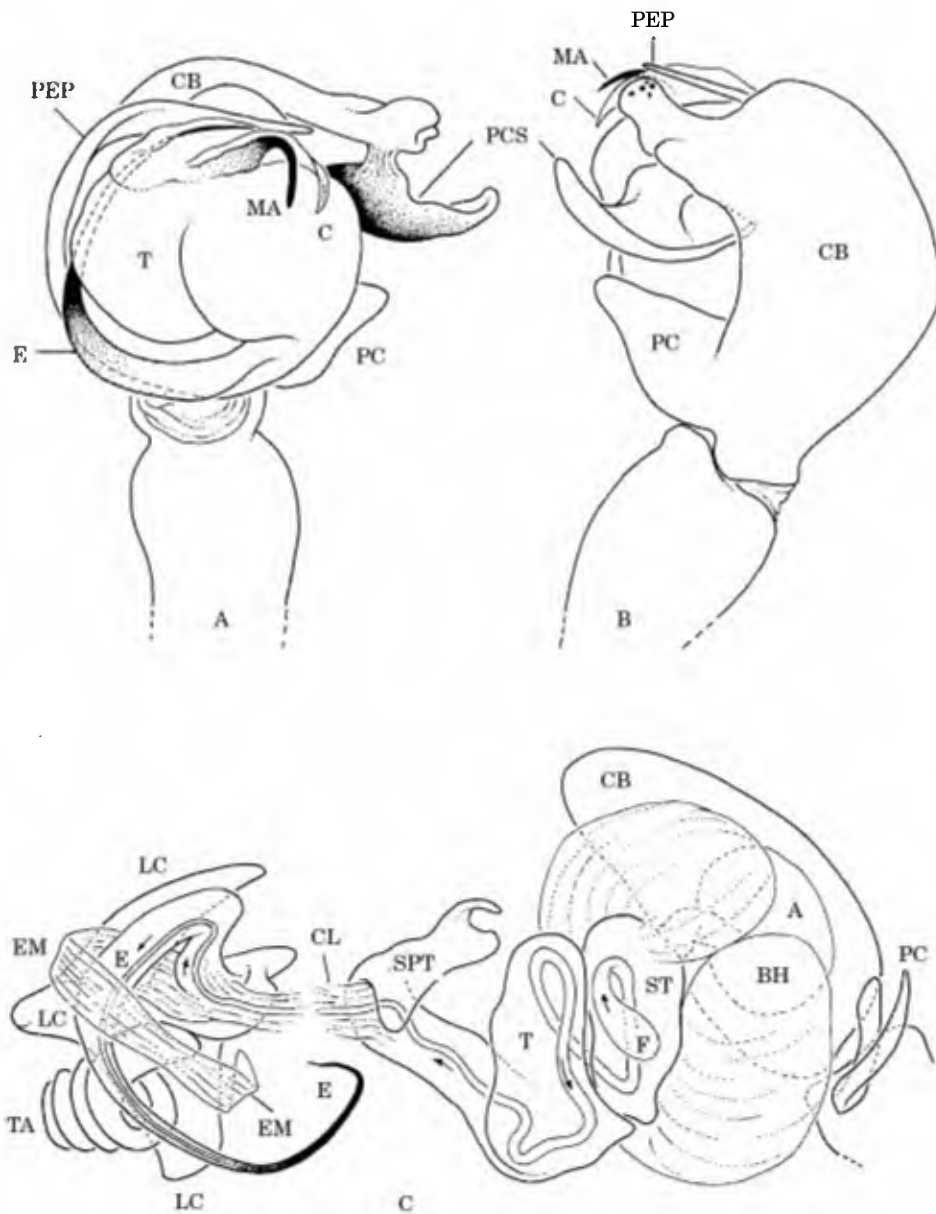

Figure 13. Male palpi. A, *Pimoides hespera*, California, USA, left, ventral (after Hormiga, 1994b, fig. 126). B, ditto, retrodorsal (after Hormiga, 1994b, fig. 128). C, *Linyphia triangularis*, schematic, expanded (after Hormiga, 1994a, fig. 9c-d).

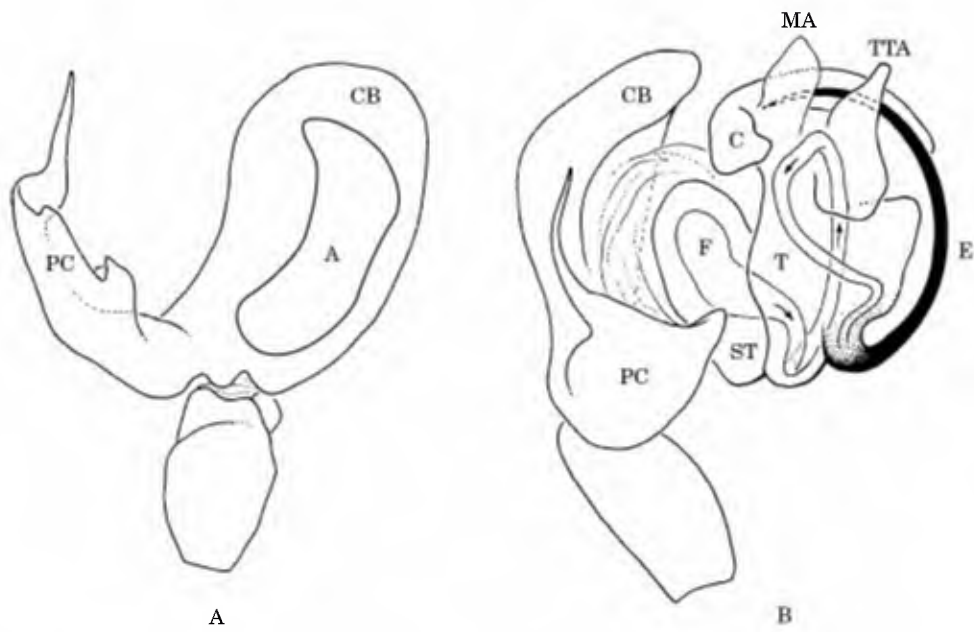

Figure 14. *Nesticus silvestrii*, Kings Canyon, California, USA, right male palp. A, cymbium and paracymbium, ventral. B, expanded bulb, retrolateral.

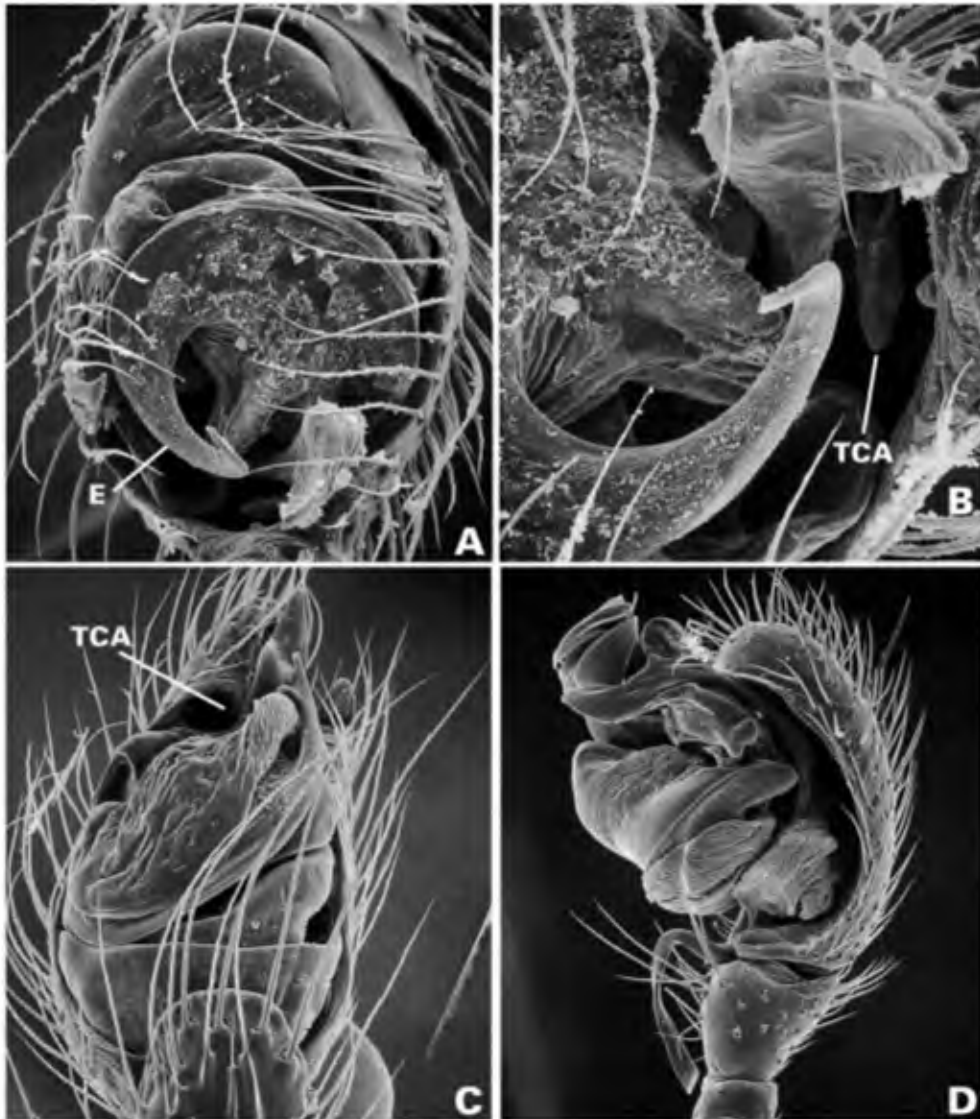

Figure 15. Right male palpi of Linyphiidae and Theridiidae. A, *Steatoda grossa*, San Francisco, California, USA, apical. B, ditto showing theridiid cymbial process. C, *Anelosimus studiosus*, Ambato, Ecuador, ventral. D, *Linyphia* sp., Turew, Poland, prolateral.

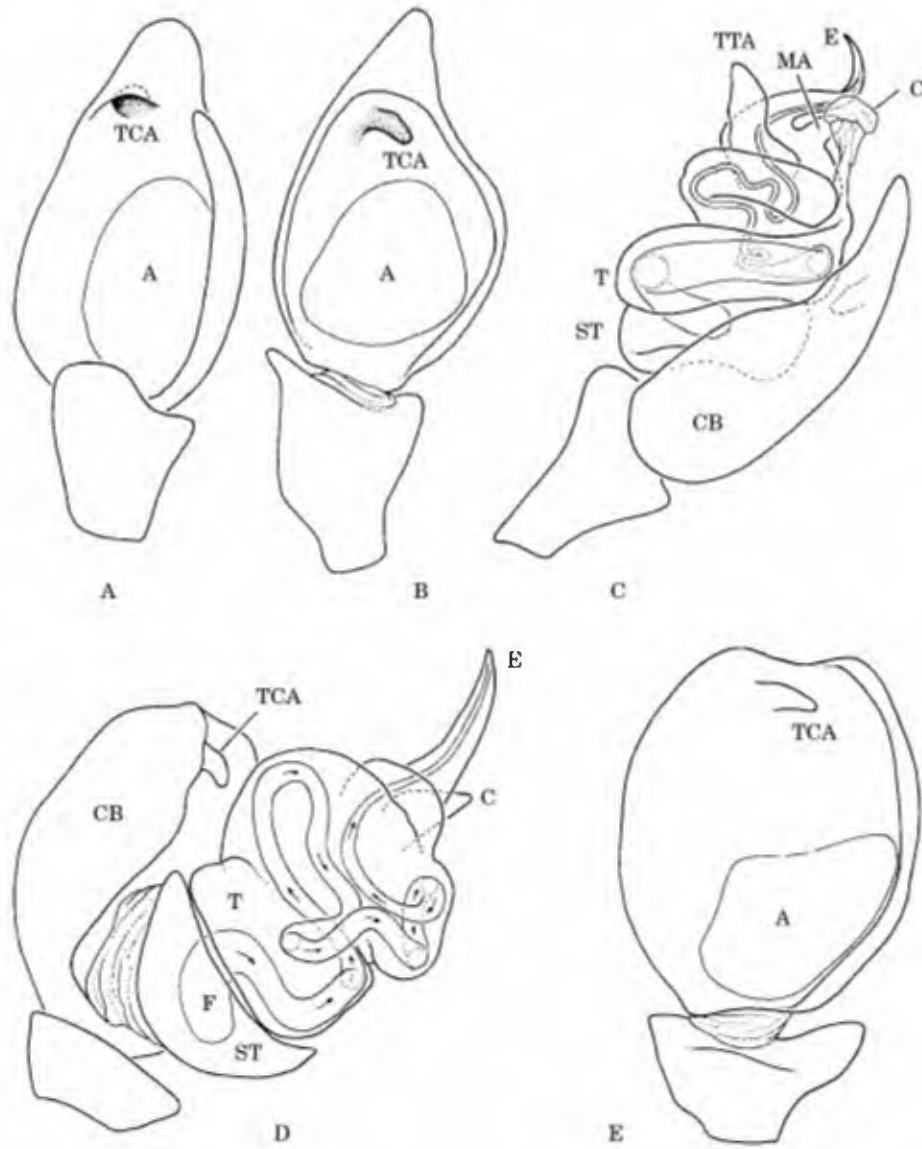

Figure 16. Right male palpi of Theridiidae. A, *Anelosimus studiosus*, Ambato, Ecuador, cymbium, ventral. B, *Steatoda grossa*, Moss Beach, California, USA, cymbium, ventral. C, ditto, expanded bulb, prolateral. D, *Euryopsis funebris*, Warrensburg, Missouri, USA, expanded bulb, retrolateral. E, ditto, cymbium, ventral.

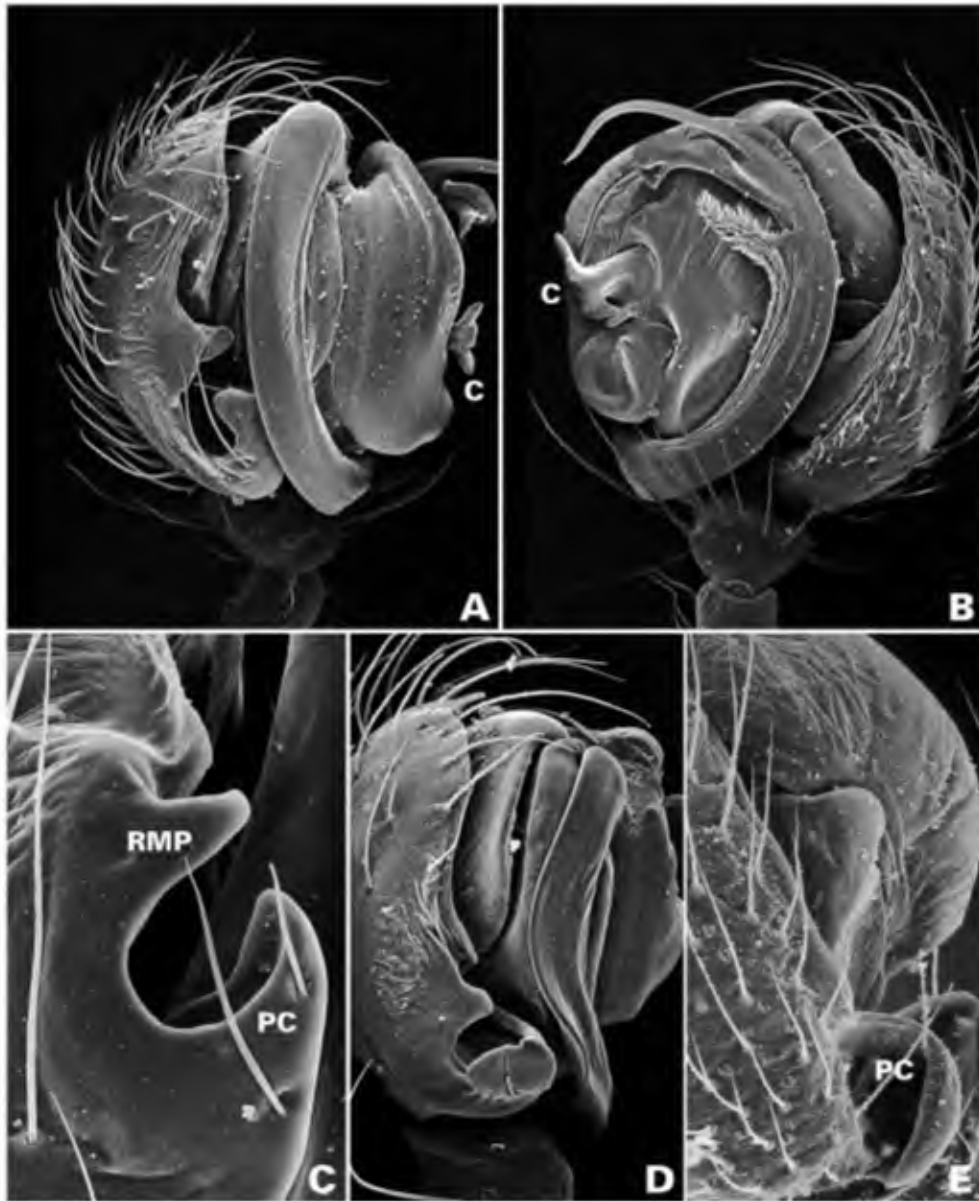

Figure 17. Right male palpi of Cyatholipidae and Synotaxidae. A, *Tekella absidata*, Peel Forest, New Zealand, retrolateral. B, ditto, prolateral. C, Cyatholipidae sp., Kivu, Zaire, cymbium, retrobasal. D, Cyatholipidae sp., Mt. Elgon, Kenya, retrolateral. E, *Pahora murihika*, Kaka Point Preserve, Otago, New Zealand, cymbium, retrobasal.

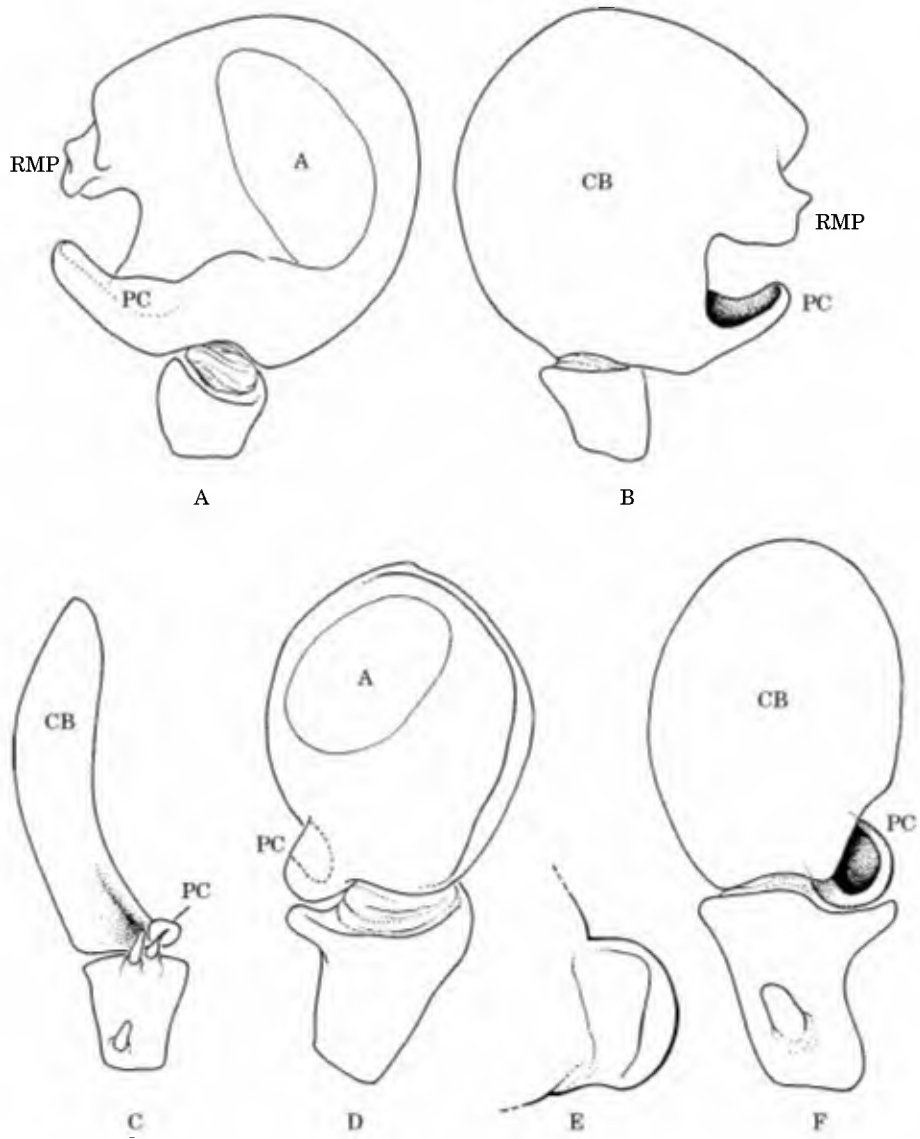

Figure 18. Right palpal tibia and cymbia of Cyatholipidae and Synotaxidae. A, *Cyatholipidae* nr. *Isicabu*, Mt. Cameroon, Cameroon, ventral. B, Ditto, dorsal. C, *Meringa otago*, Opoho Bush, Dnnedin, New Zealand, retrolateral. D, *Pahora murihiku*, Kaka Point Preserve, Otago, New Zealand, ventral. E, ditto, paracymbium, retrodorsal. F, ditto, dorsal.

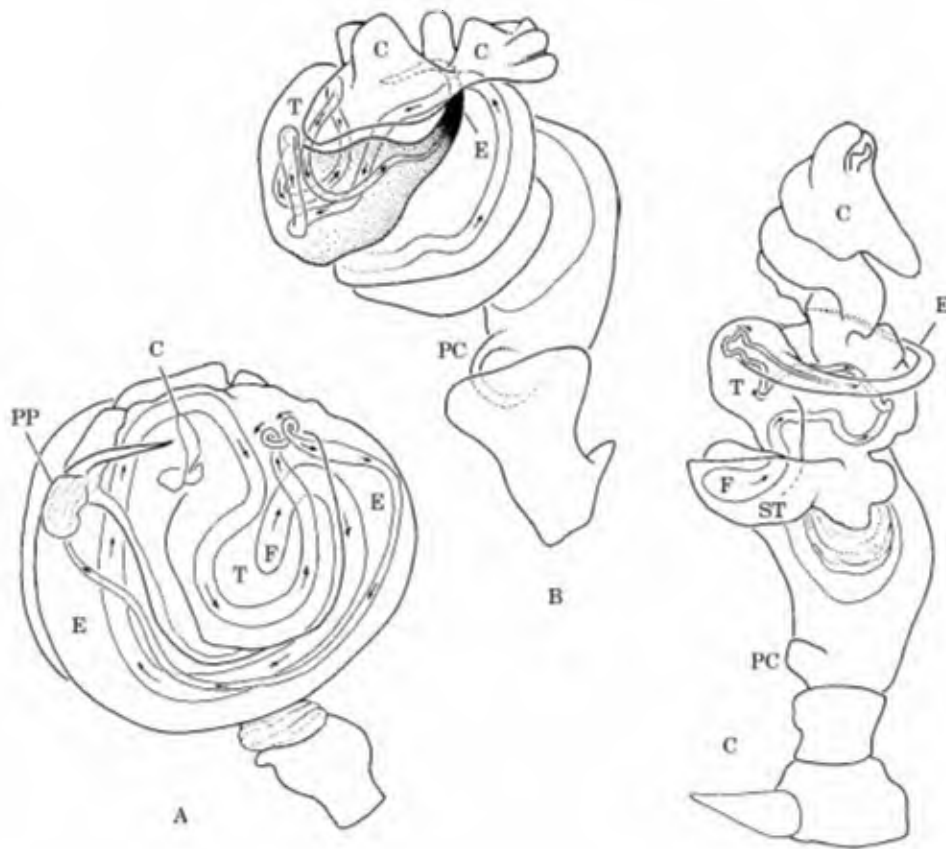

Figure 19. Right male palpi of Cyatholipidae and Synotaxidae. A, *Cyatholipidae* nr. *Isicabu*, Mt. Cameroon, Cameroon, ventral. B, *Pahora murihiku*, Kaka Point Preserve, Otago, New Zealand, expanded, ventral. C, *Synotaxus turbinatus*, La Selva, Costa Rica, expanded, ventral.

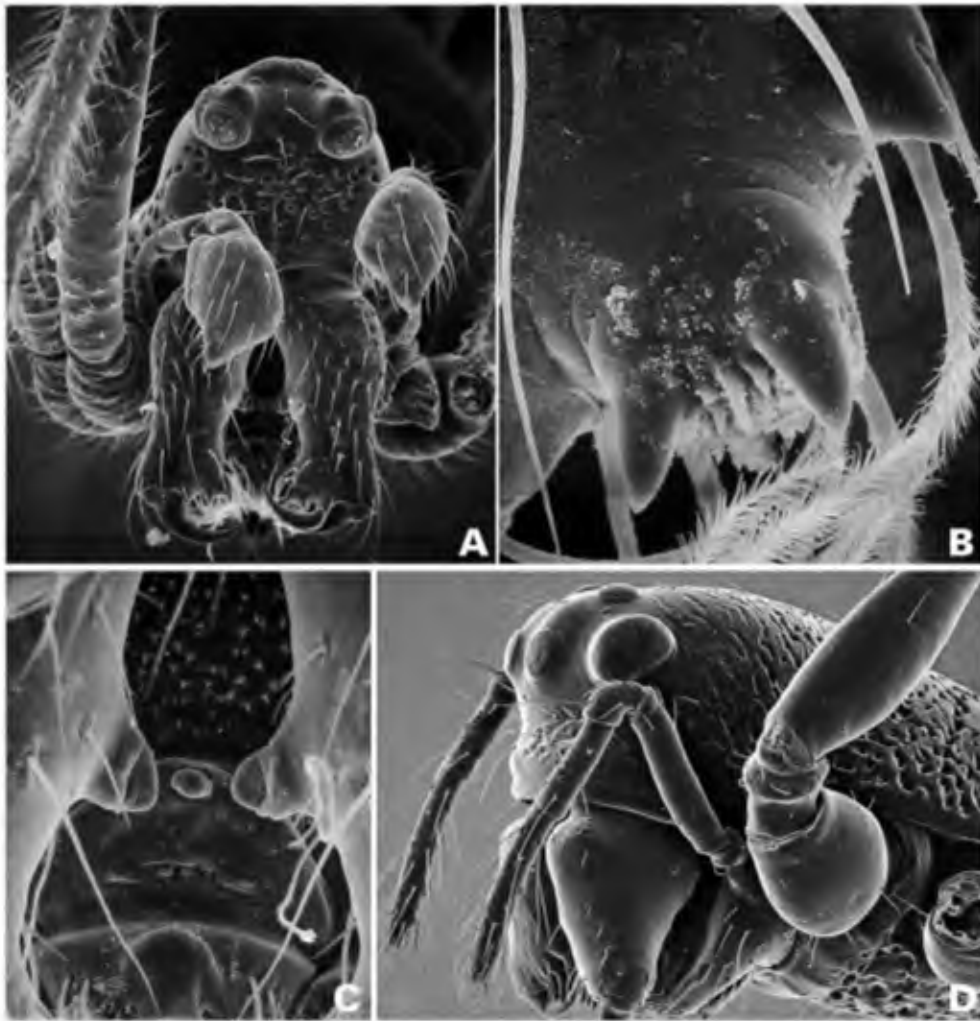

Figure 20. A, *Anapis* sp., Rio Tigre, Bolivia, male carapace, anterior. B, ditto, cheliceral teeth, anterior. C, ditto, labral spur. D, *Cyatholipidae* sp., Mwanihana, Tanzania, female cephalothorax, lateral.

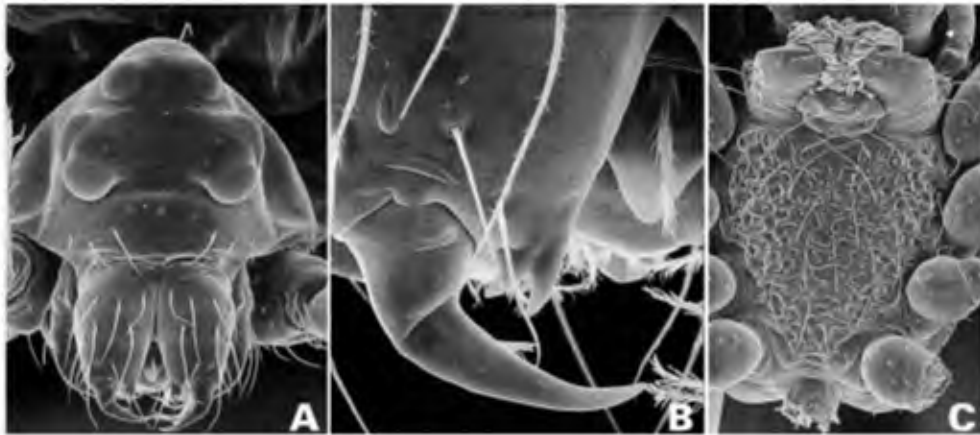

Figure 21. A, *Patu* (?) sp., female, Kuranda, Australia, cephalothorax, anterior. B, ditto, cheliceral teeth, anterior. C, Cyatholipidae nr. *Isicabu*, Mt. Oku, Cameroon, female, venter of cephalothorax.

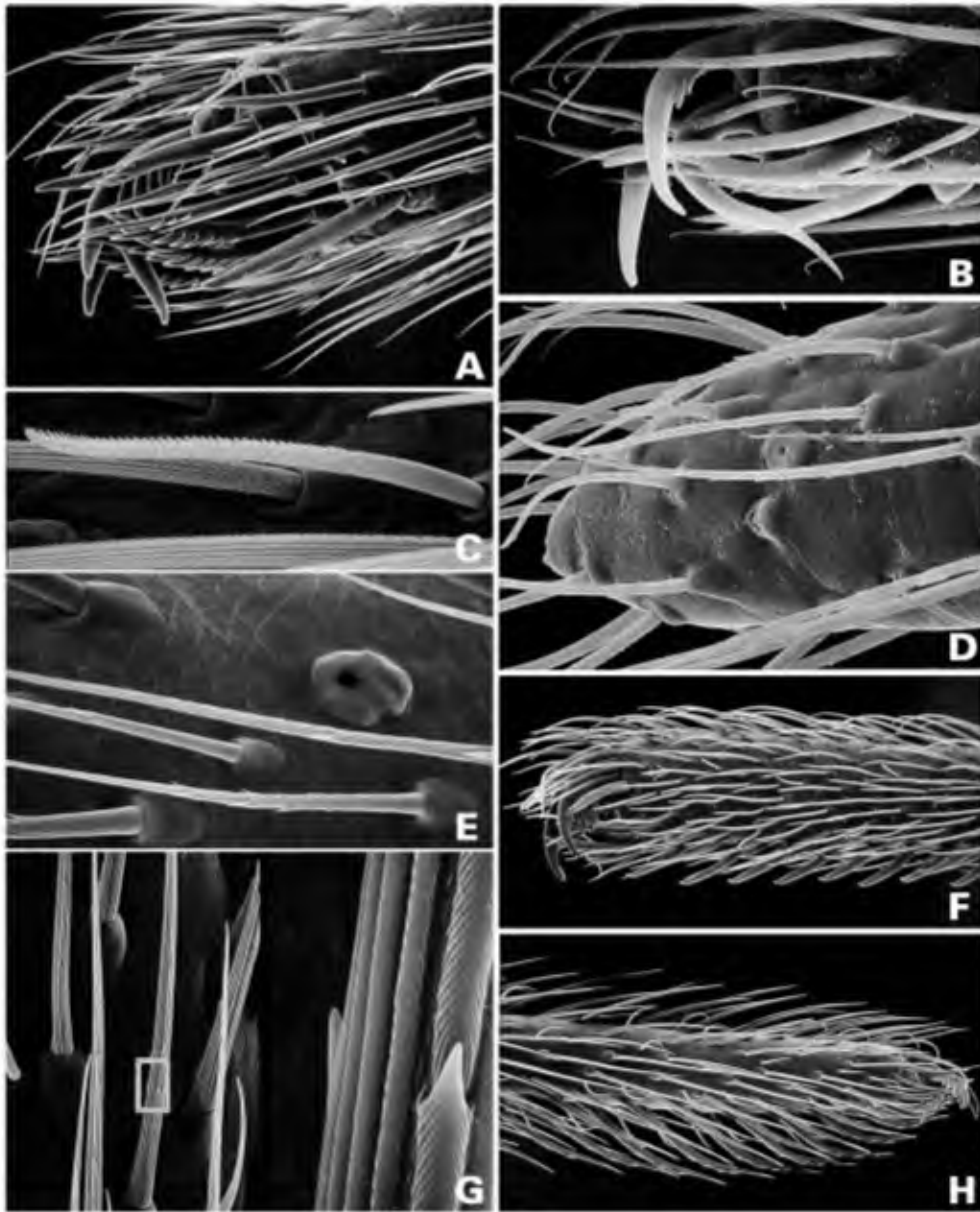

Figure 22. Legs of orbiculariae. A, E, *Metepeira* sp., Guanajuato, Mexico, tarsus IV. B, *Maymena mayana*, Veracruz, Mexico, tarsus IV. C, F, *Deinopis spinosus*, Gainesville, Florida, USA, tarsus IV. D, Cyatholipidae nr. *Isicabu*, Mt. Oku, Cameroon. G, H, *Steatoda grossa*, San Francisco, California, USA, tarsus IV. A, serrate accessory claw setae and sustentaculum. B, elongate median claw. C, plumose hairs. D, female palpal tarsus, lacking claw. E, G, serrate hairs. F, 'Deinopoid' tarsal comb. H, serrate theridioid tarsus IV comb.

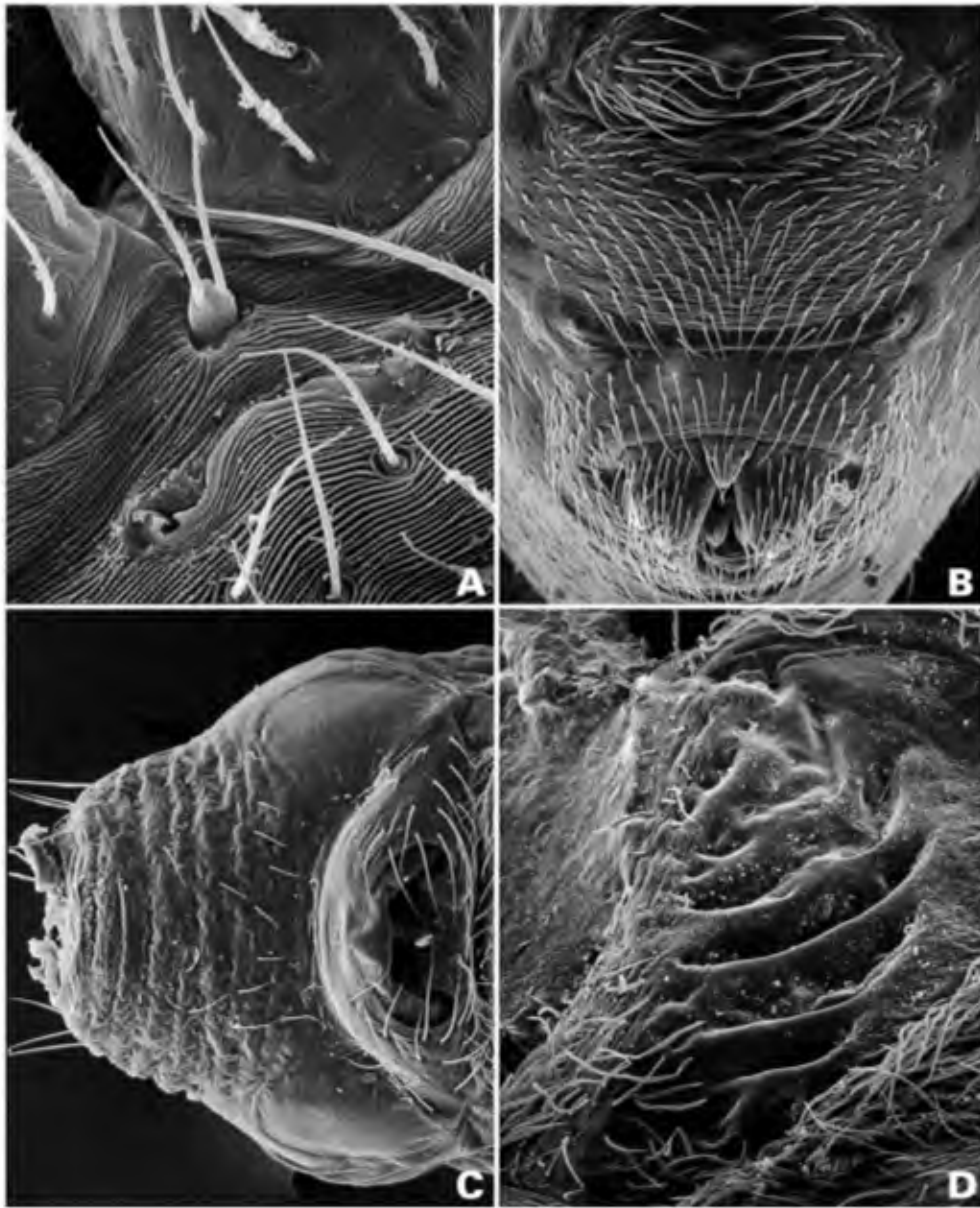

Figure 23. Abdomens of Araneoidea. A, *Patu digua*, Riseralda, Colombia, male, spiracle and colulus. B, *Cyatholipidae* sp., Ethiopia, female, venter showing spiracle and colulus. C, *Cyatholipidae* sp., Mt. Mlanje, Malawi, female, venter showing smooth booklung covers. D, *Argiope argentata*, Miller's Landing, Baja California, Mexico, female, grooved booklung cover.

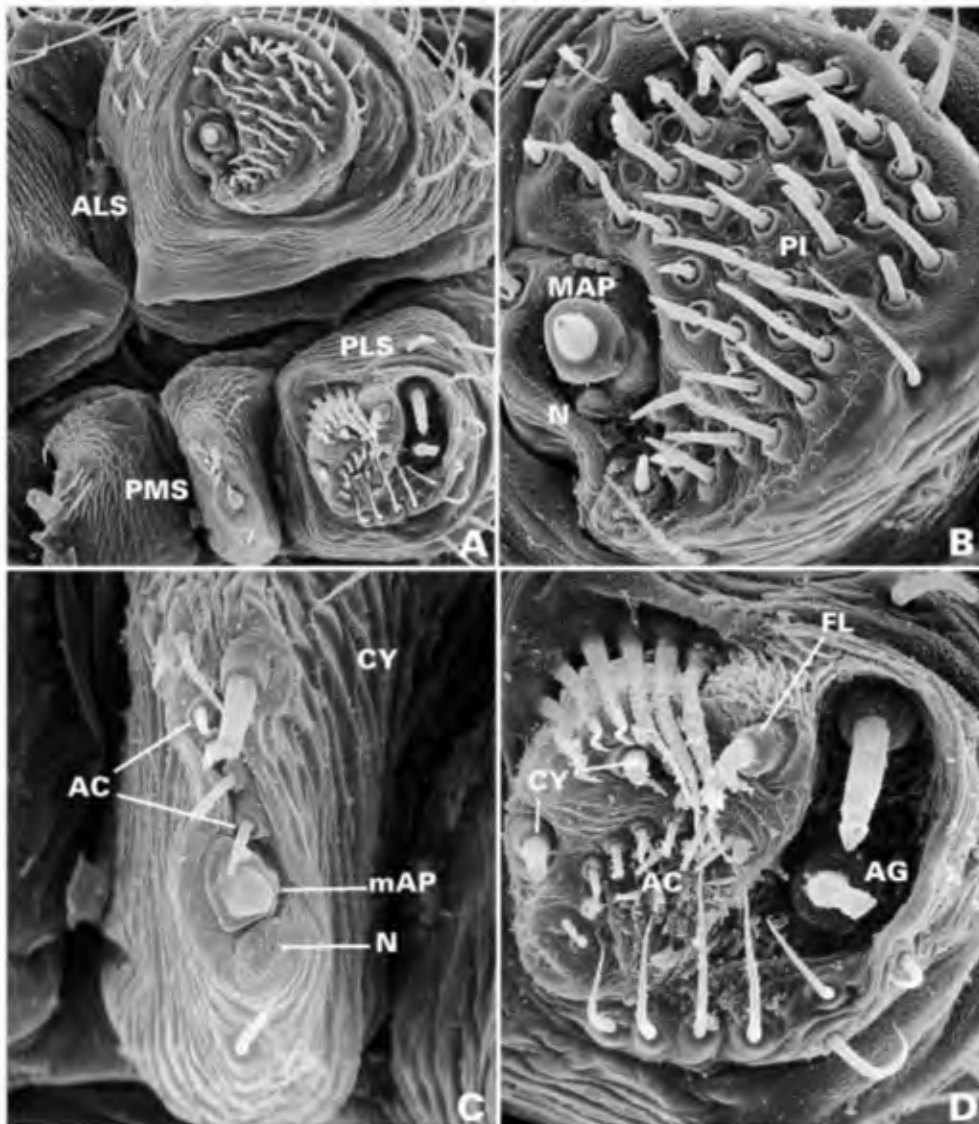

Figure 24. *Epeirotypus chavarría*, La Selva, Costa Rica, female spinnerets. A, left spinneret group. B, anterior lateral spinneret. C, posterior median spinneret. D, posterior lateral spinneret.



Figure 25. *Epeirotypus chavarría*, La Selva, Costa Rica, male spinnerets. A, left spinneret group. B, anterior lateral spinnerets. C, posterior median spinnerets. D, posterior lateral spinneret.

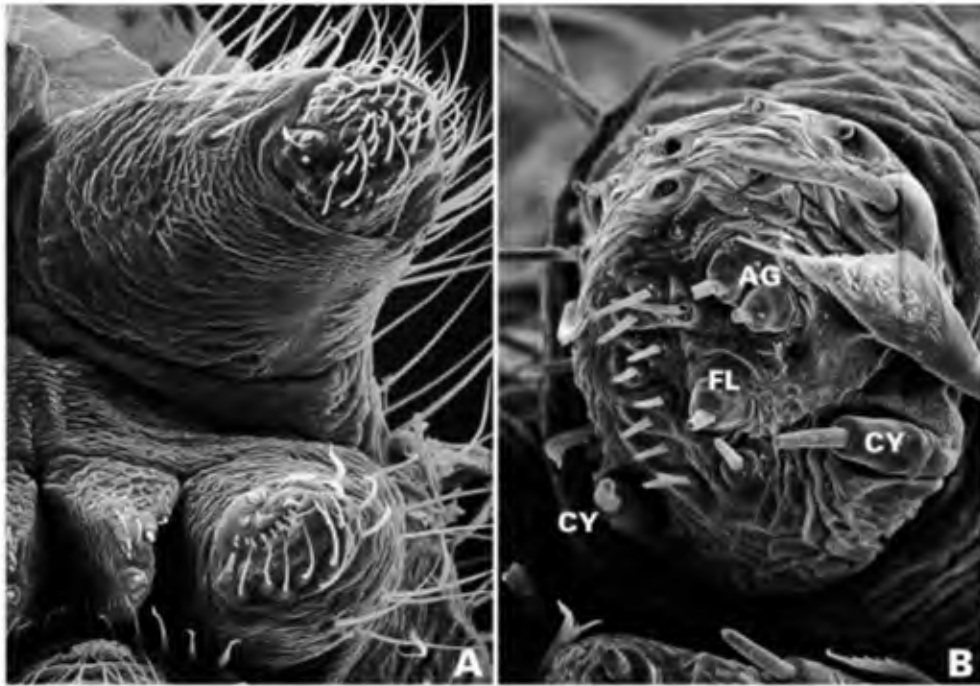

Figure 26. *Maymena mayana*, Veracruz, Mexico, female spinnerets. A, left spinneret group. B, posterior lateral spinneret.

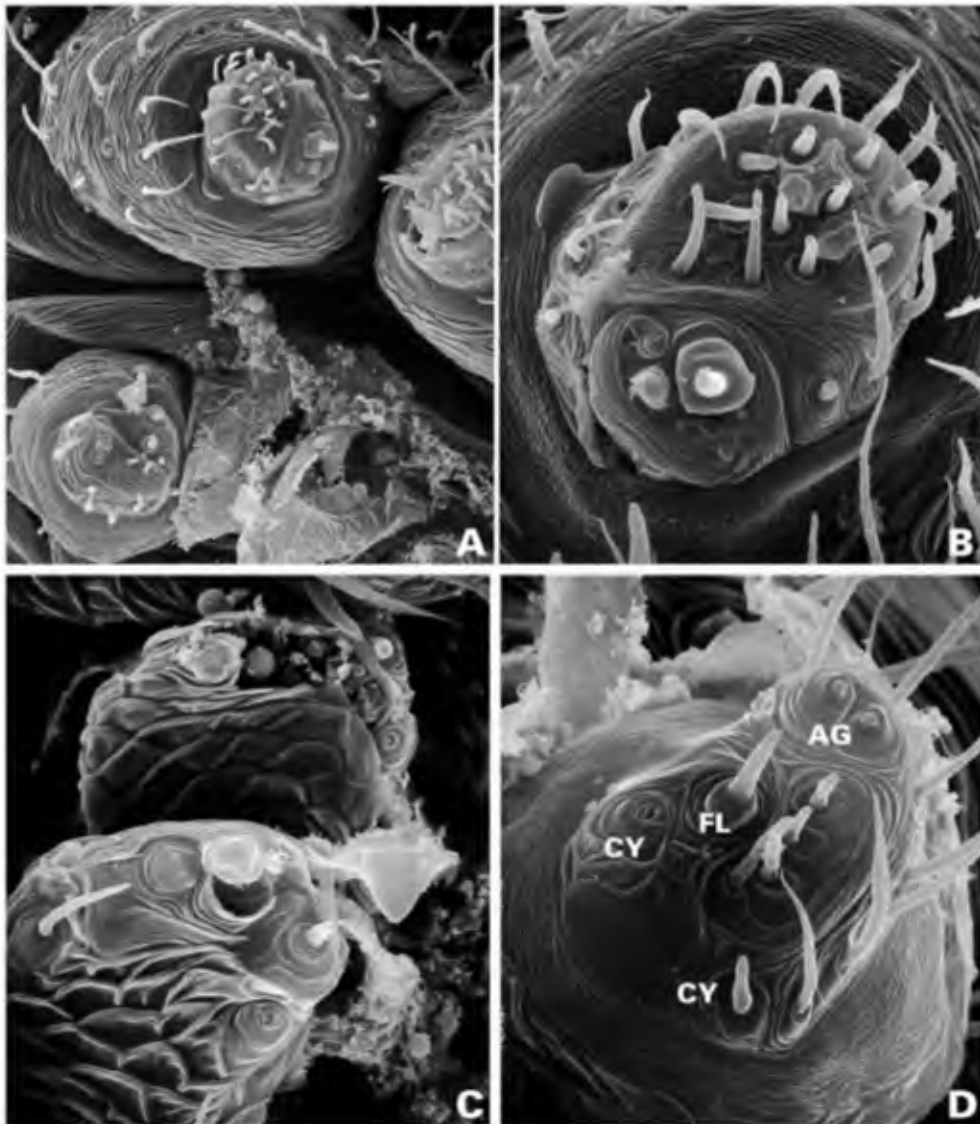

Figure 27. *Mysmena* (?) sp., Kuranda, Australia, female spinnerets. A, right spinneret group. B, anterior lateral spinneret. C, posterior median spinnerets. D, posterior lateral spinneret (left).

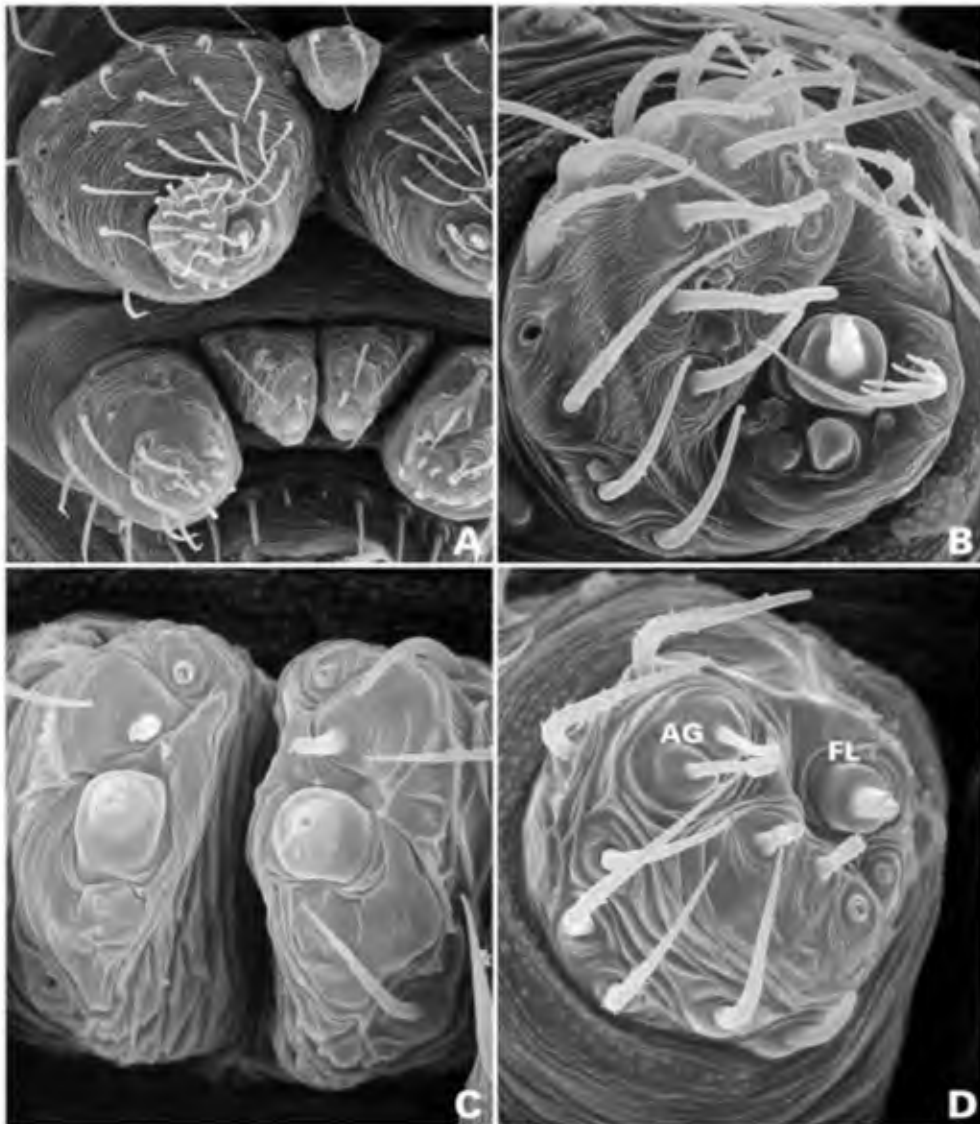

Figure 28. *Mysmena* (?) sp., Kuranda, Australia, male spinnerets. A, right spinneret group. B, anterior lateral spinneret. C, posterior median spinnerets. D, posterior lateral spinneret.

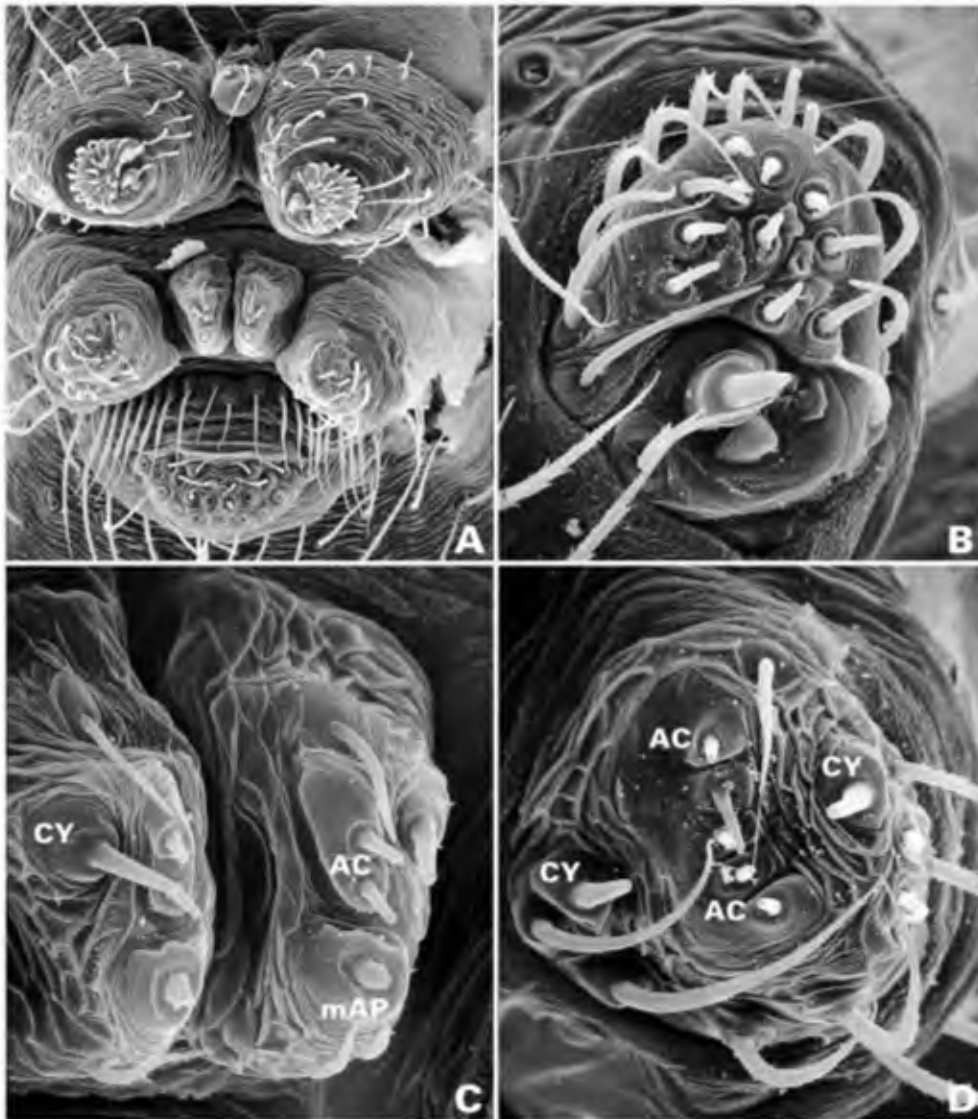

Figure 29. *Isela* sp., Mt. Cameroon, Cameroon, female spinnerets. A, spinneret group. B, anterior lateral spinneret (left). C, posterior median spinnerets. D, posterior lateral spinneret (left).

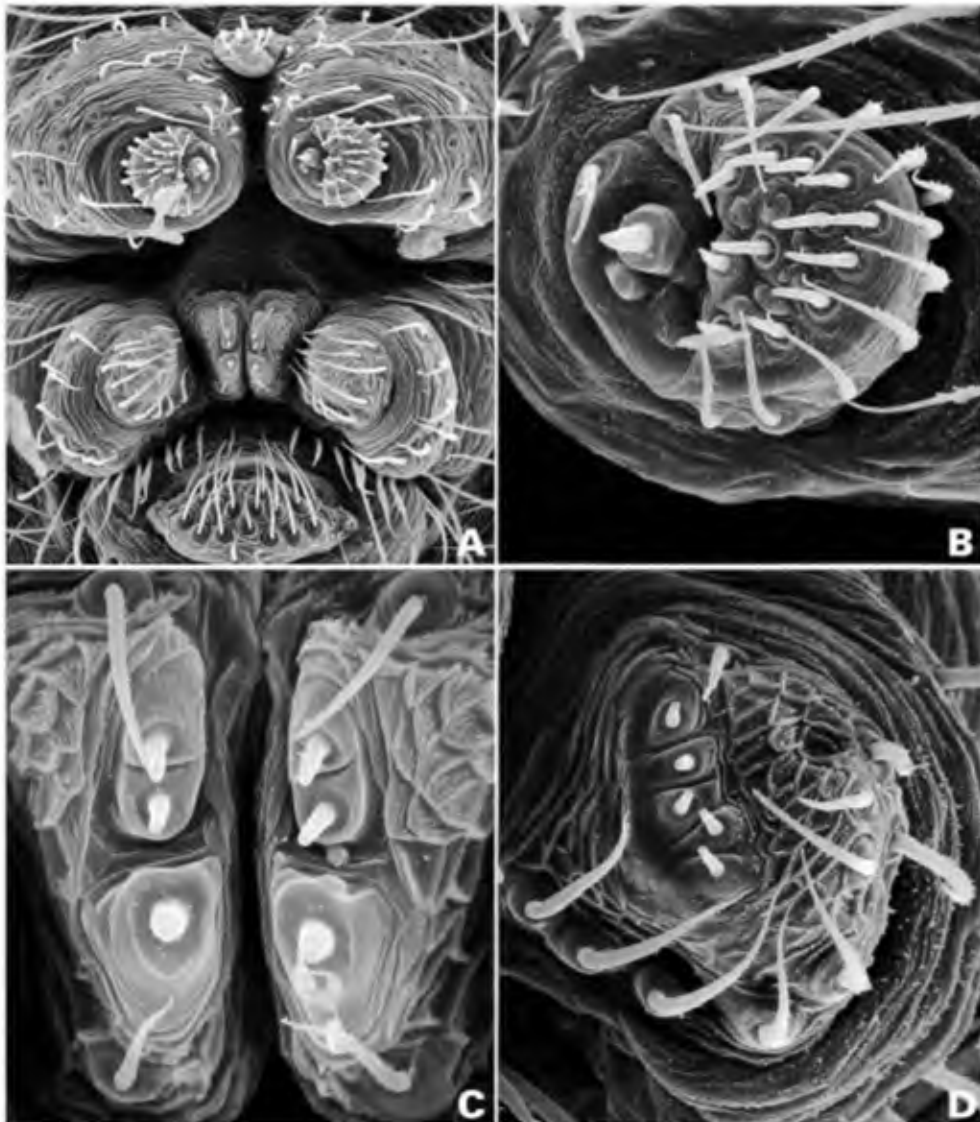

Figure 30. *Isela* sp., Mt. Cameroon, Cameroon, male spinnerets. A, spinneret group. B, anterior lateral spinneret (left). C, posterior median spinnerets. D, posterior lateral spinneret (left).

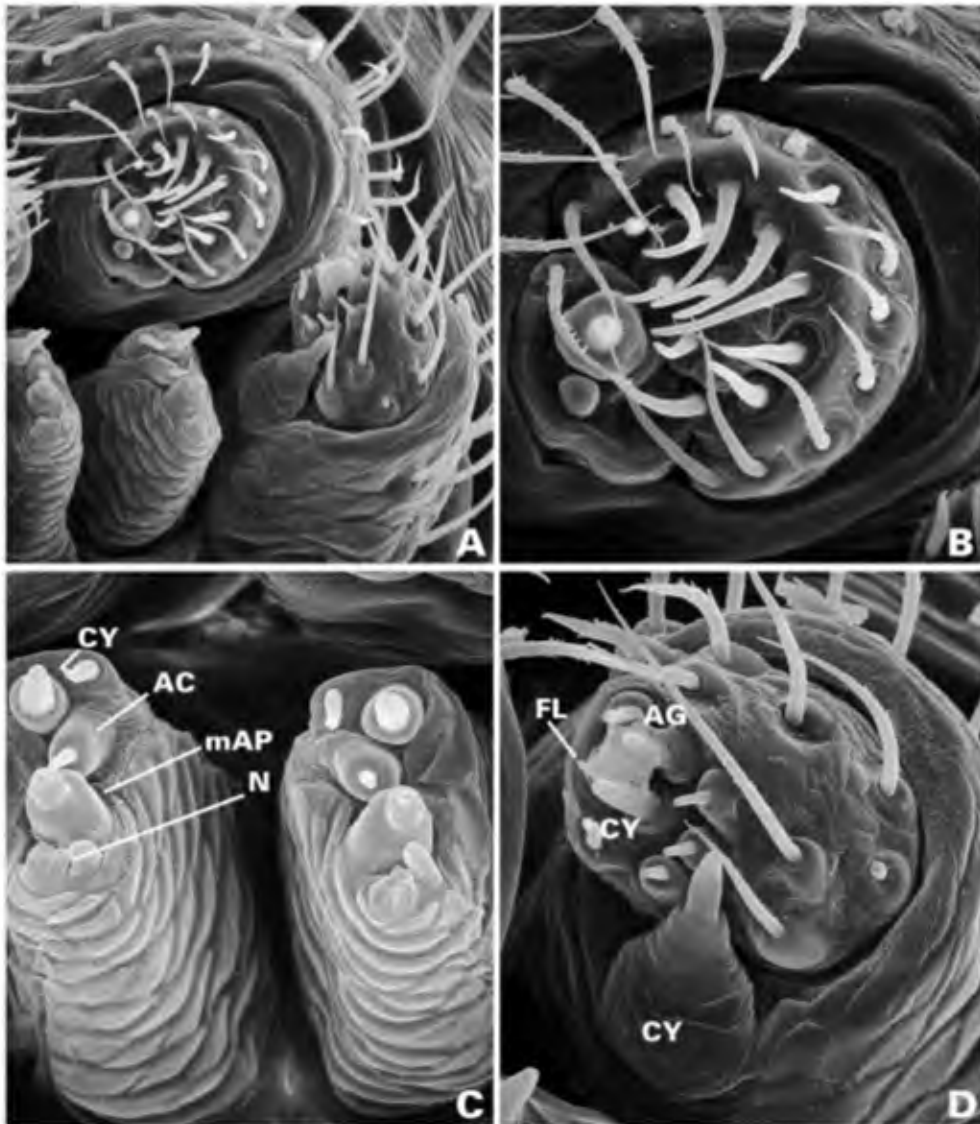

Figure 31. *Anapis* sp., Rio Tigré, Bolivia, female spinnerets. A, spinneret group (left). B, anterior lateral spinneret. C, posterior median spinnerets. D, posterior lateral spinneret.

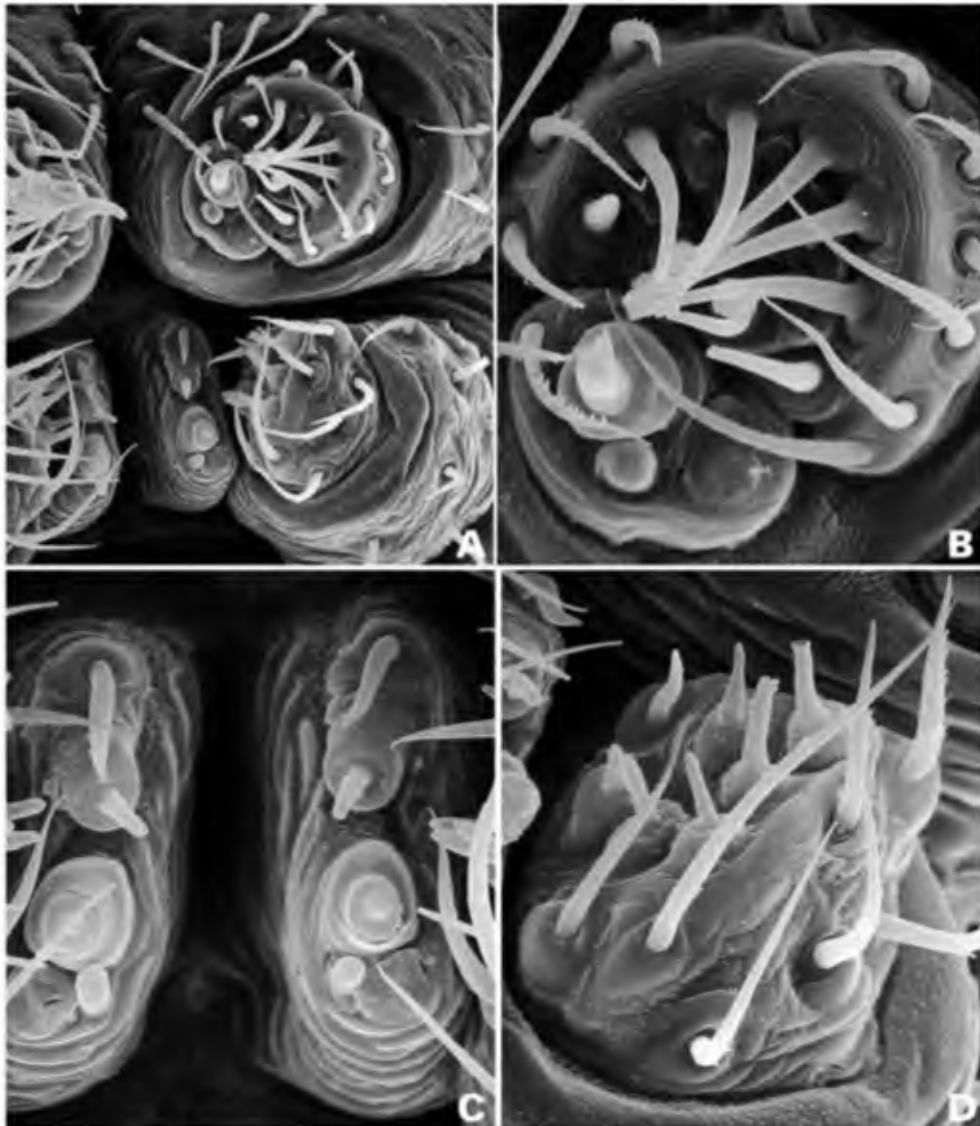

Figure 32. *Anapis* sp., Rio Tigre, Bolivia, male spinnerets. A, spinneret group (left). B, anterior lateral spinneret. C, posterior median spinnerets. D, posterior lateral spinneret.

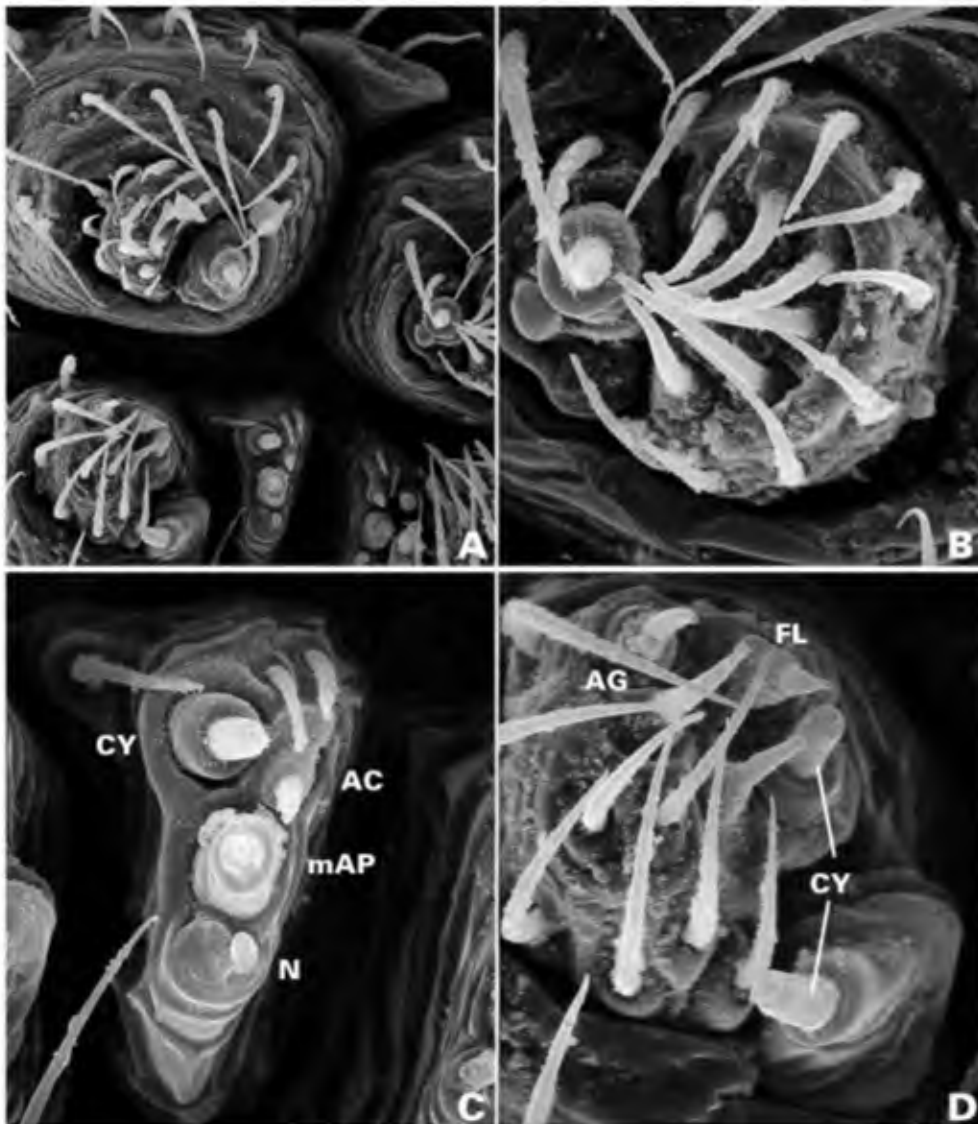

Figure 33. *Gertschanapis shantzi*, Monterey Co., California, female spinnerets. A, spinneret group (right). B, anterior lateral spinneret (left). C, posterior median spinneret (right). D, posterior lateral spinneret (right).

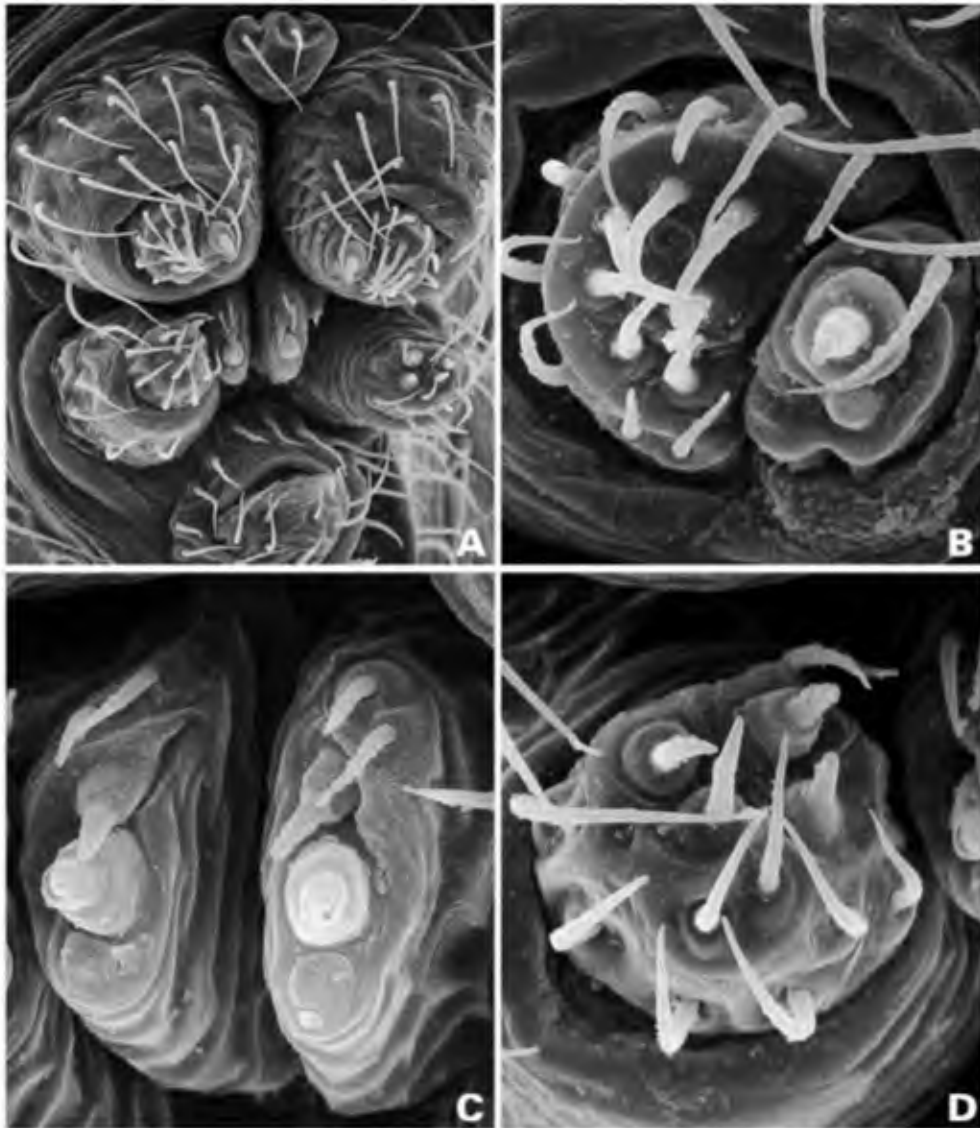

Figure 34. *Gertschanapis shantzi*, Monterey Co., California, male spinnerets. A, spinneret group. B, anterior lateral spinneret, (right). C, posterior median spinnerets. D, posterior lateral spinneret (right).

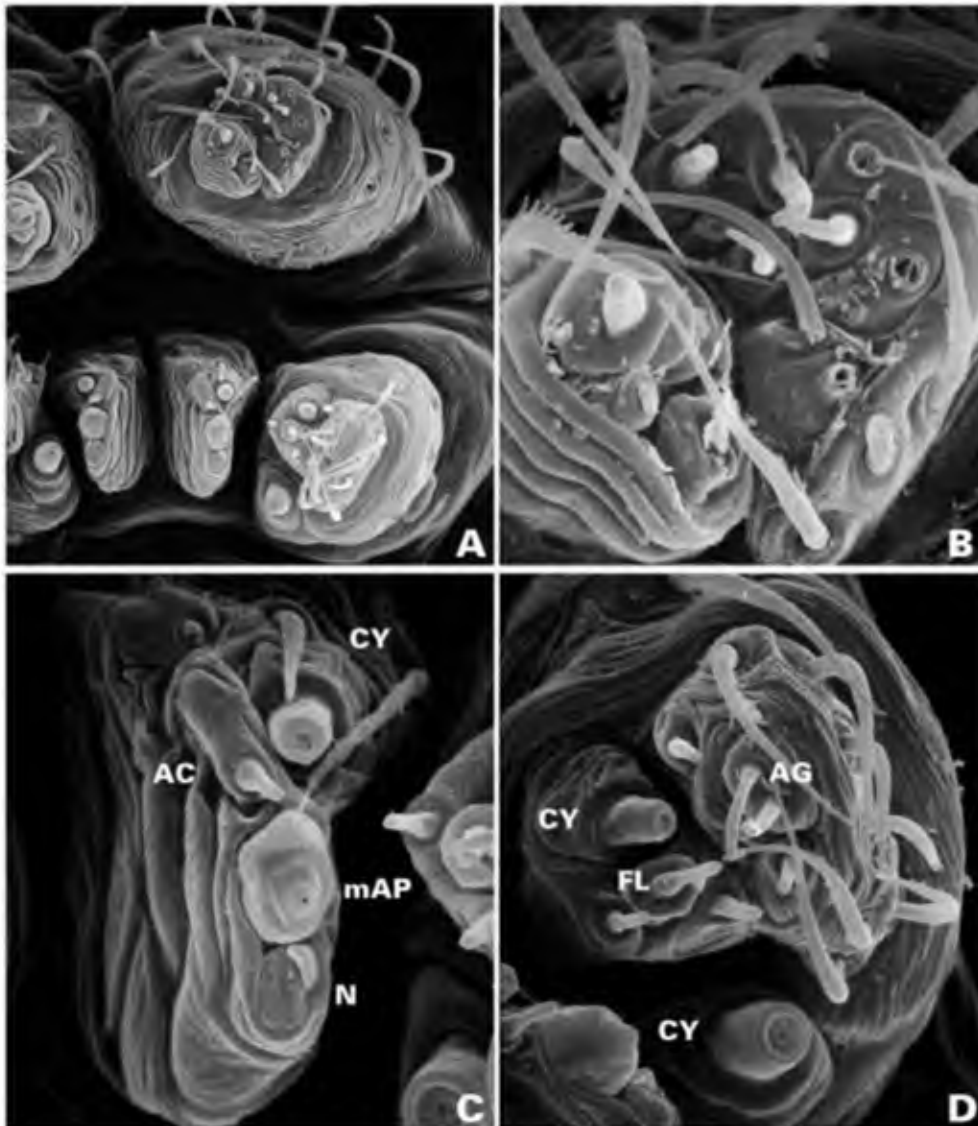

Figure 35. Symphytognathid, *Patu?* sp., Kuranda, Queensland, Australia, female spinnerets. A, spinneret group (left). B, anterior lateral spinneret. C, posterior median spinneret. D, posterior lateral spinneret.

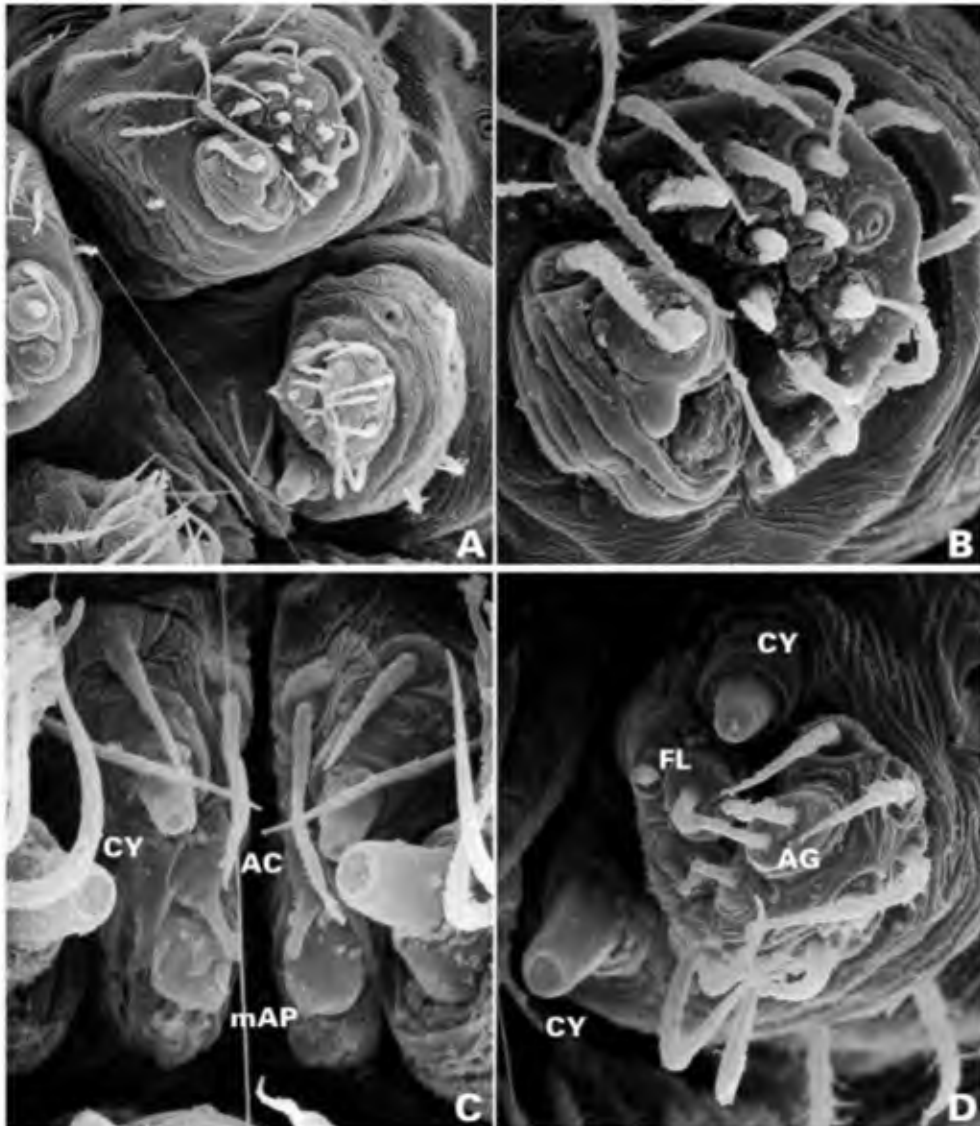

Figure 36. *Patu digua*, Riseralda, Colombia, female spinnerets. A, spinneret group (left). B, anterior lateral spinneret. C, posterior median spinnerets. D, posterior lateral spinneret.



Figure 37. *Patu digua*, Riseralda, Colombia, male spinnerets. A, spinneret group (left). B, anterior lateral spinneret (right). C, posterior median spinnerets. D, posterior lateral spinneret (right).

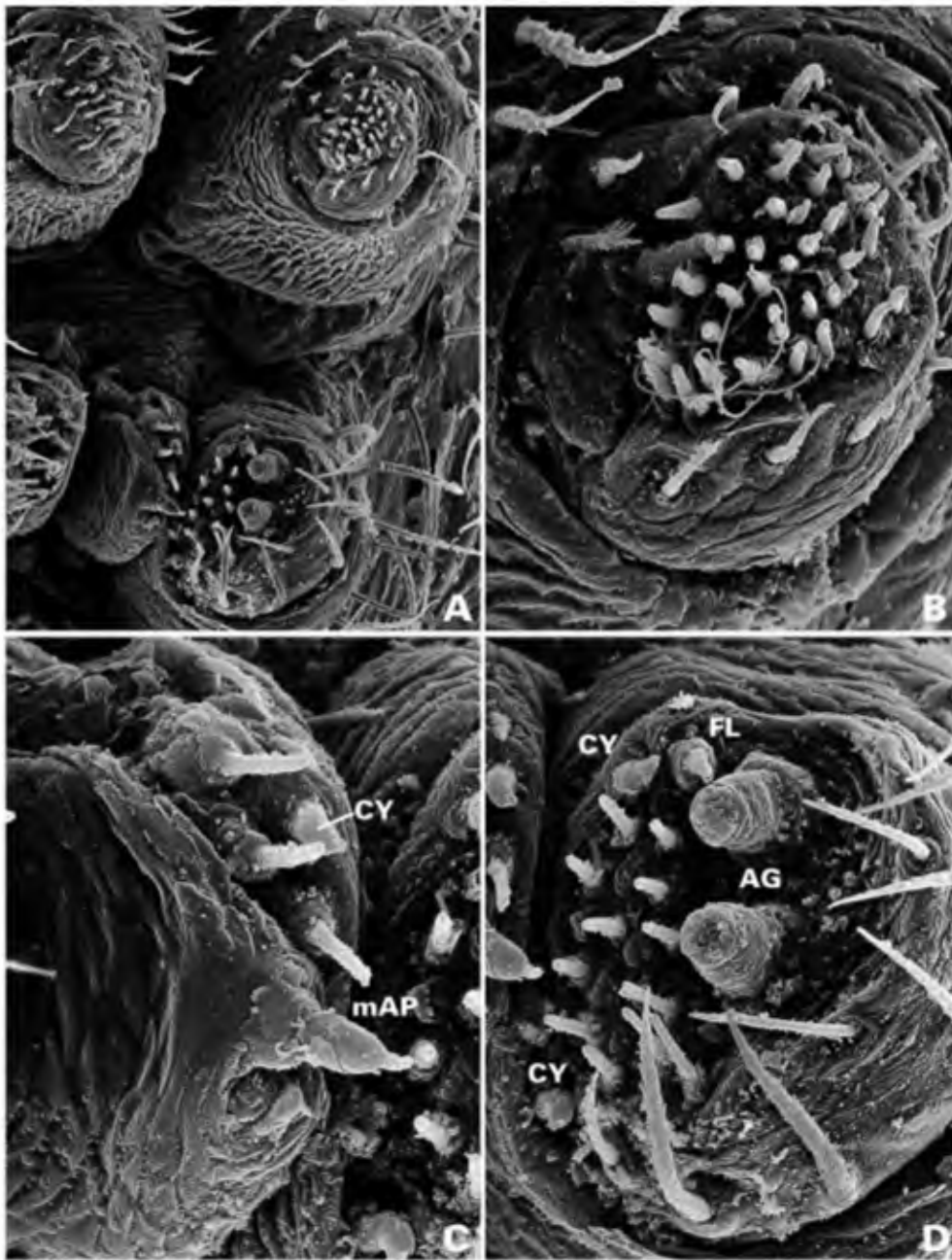

Figure 38. *Syntaxus* sp., Pakitza, Peru, female spinnerets. A, spinneret group (left). B, anterior lateral spinneret. C, posterior median spinnerets. D, posterior lateral spinneret.

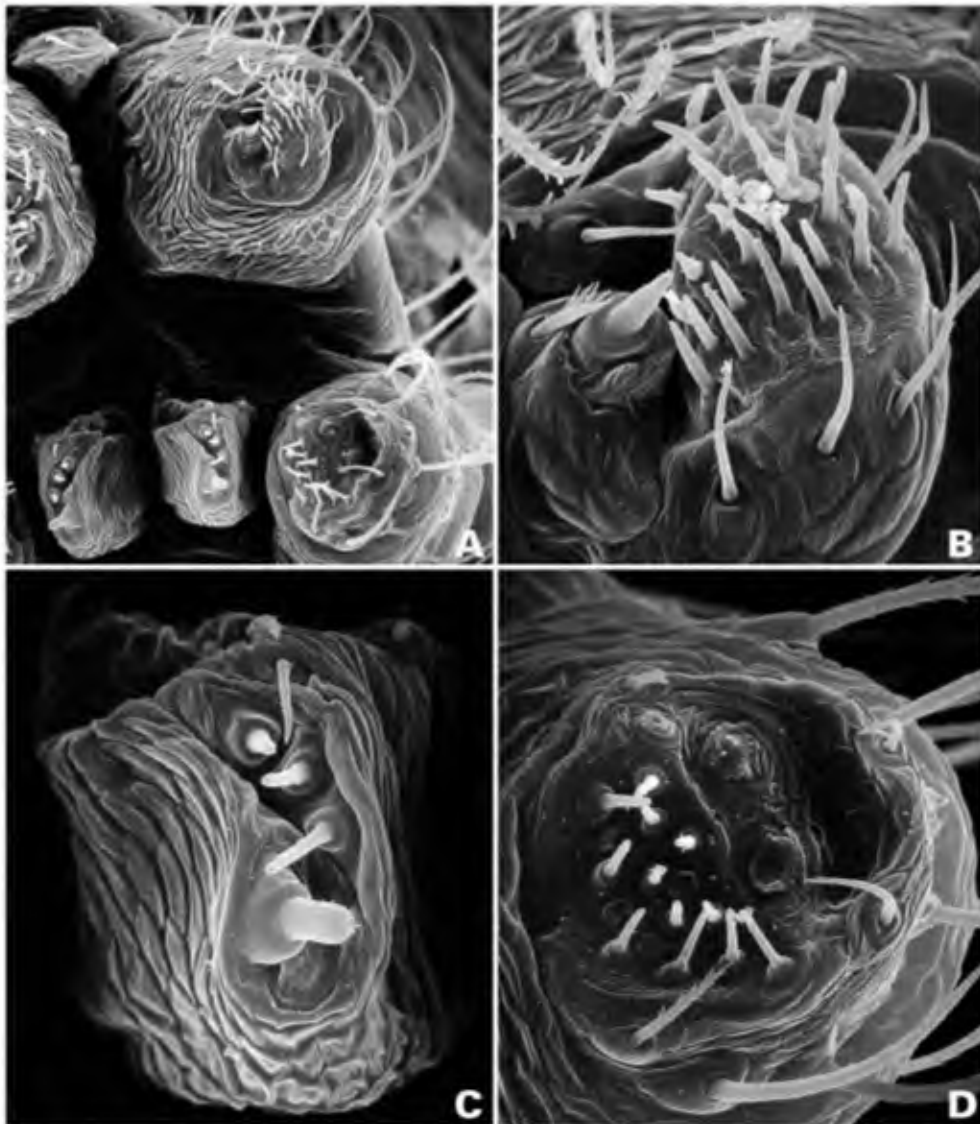

Figure 39. *Syntaxis* sp., Pakitza, Peru, male spinnerets. A, spinneret group (left). B, anterior lateral spinneret. C, posterior median spinneret. D, posterior lateral spinneret.

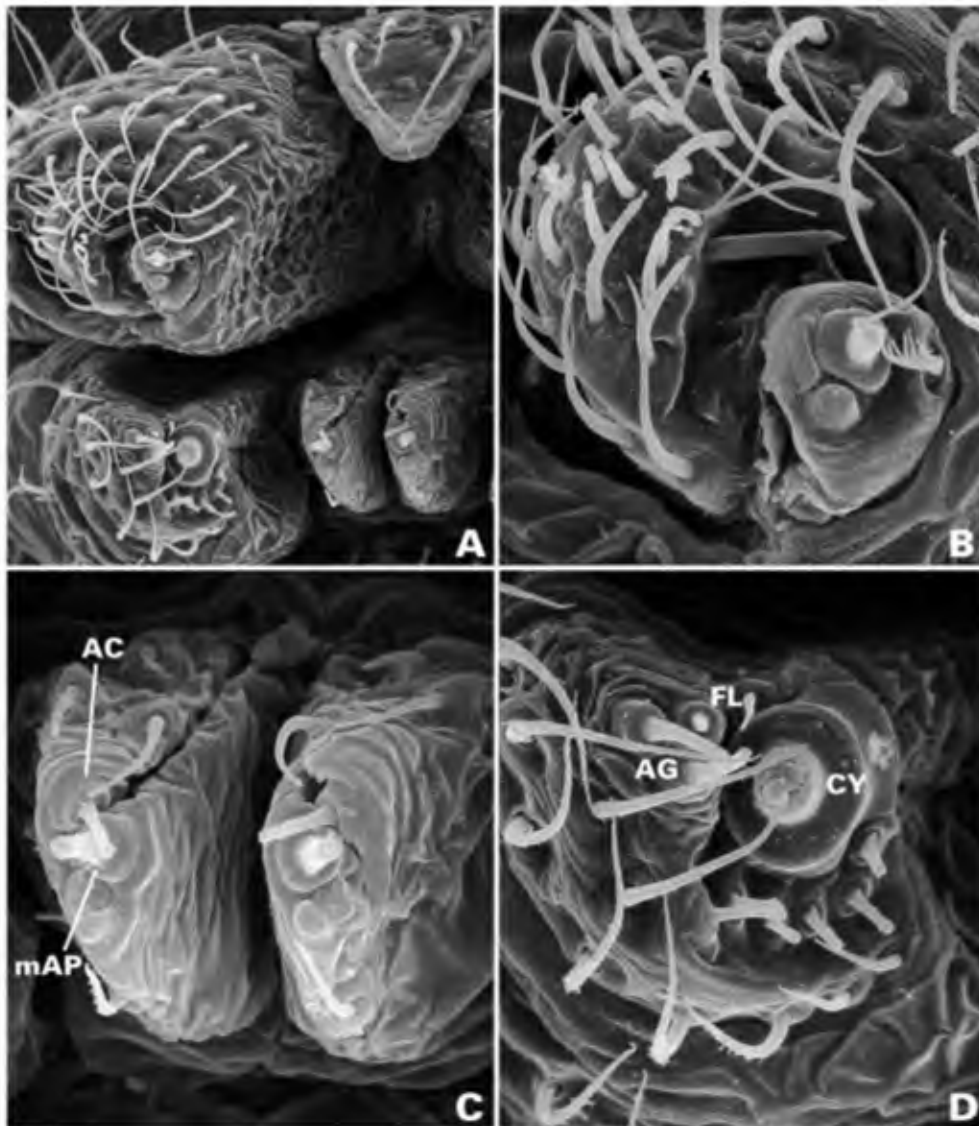

Figure 40. *Chileotaxus sauis*, 8 mi. W. Puerto Varas, Chile, female spinnerets. A, spinneret group (right). B, anterior lateral spinneret. C, posterior median spinnerets. D, posterior lateral spinneret.

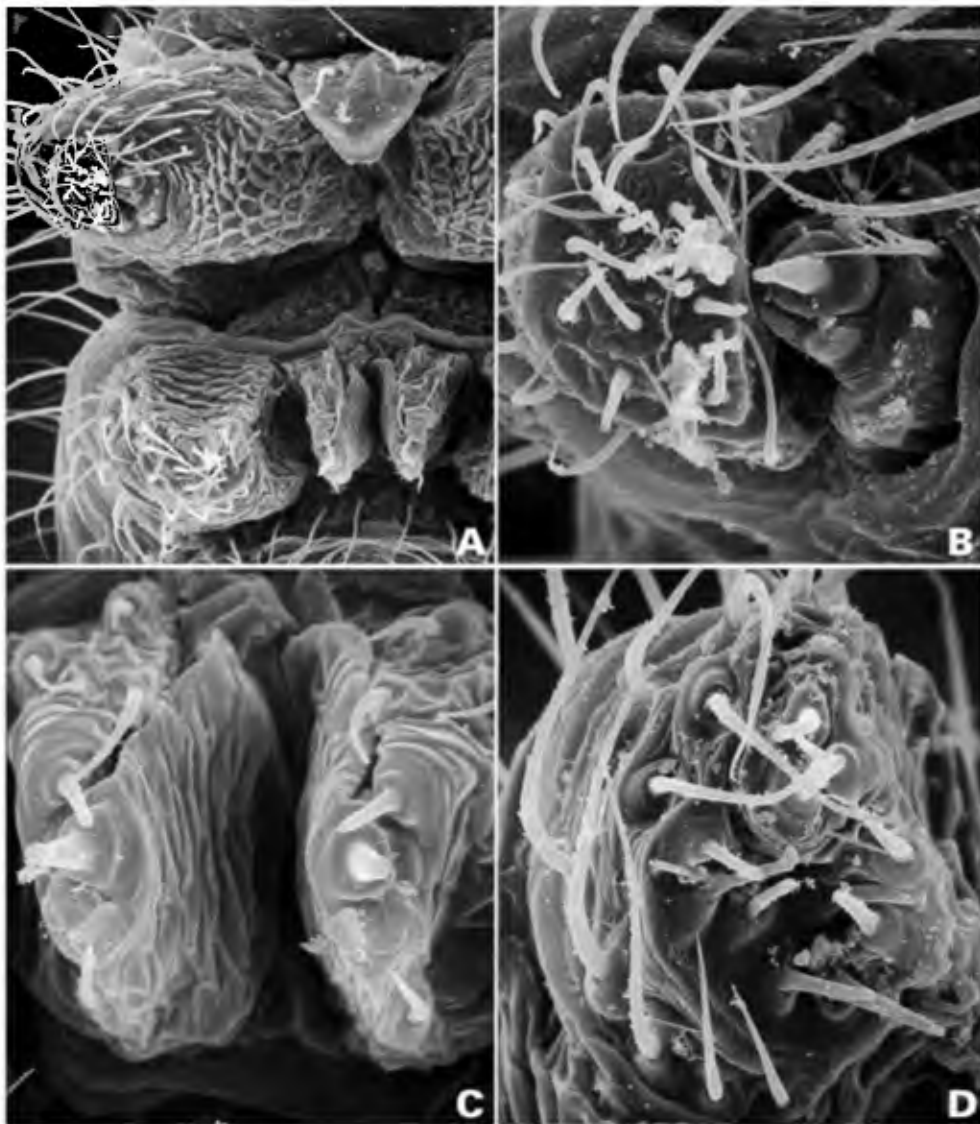

Figure 41. *Chileotaxus sans*, 8 mi. W. Puerto Varas, Chile, male spinnerets. A, spinneret group (right). B, anterior lateral spinneret. C, posterior median spinnerets. D, posterior lateral spinneret.

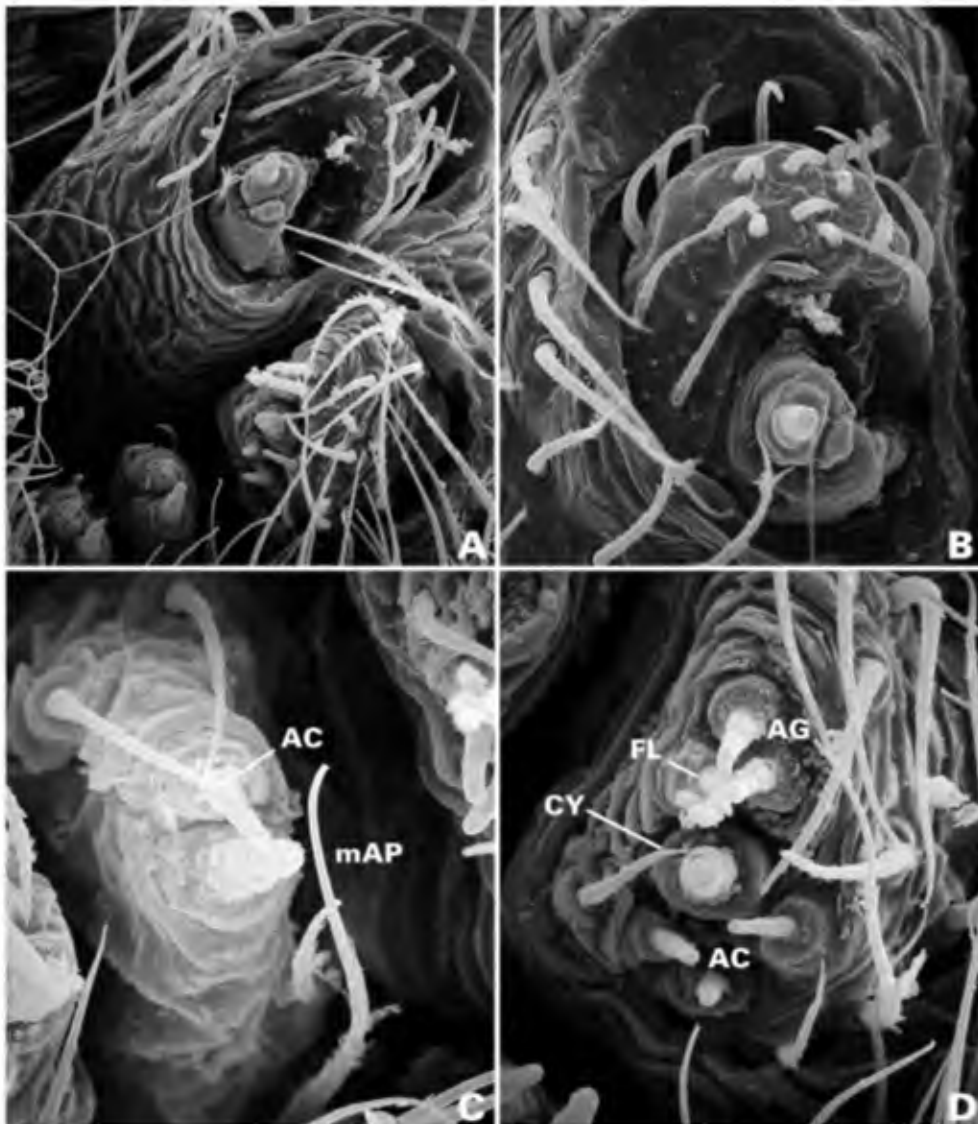

Figure 42. *Pahora murihiku*, Otago, New Zealand, female spinnerets. A, spinneret group (left). B, anterior lateral spinneret. C, posterior median spinneret. D, posterior lateral spinneret.

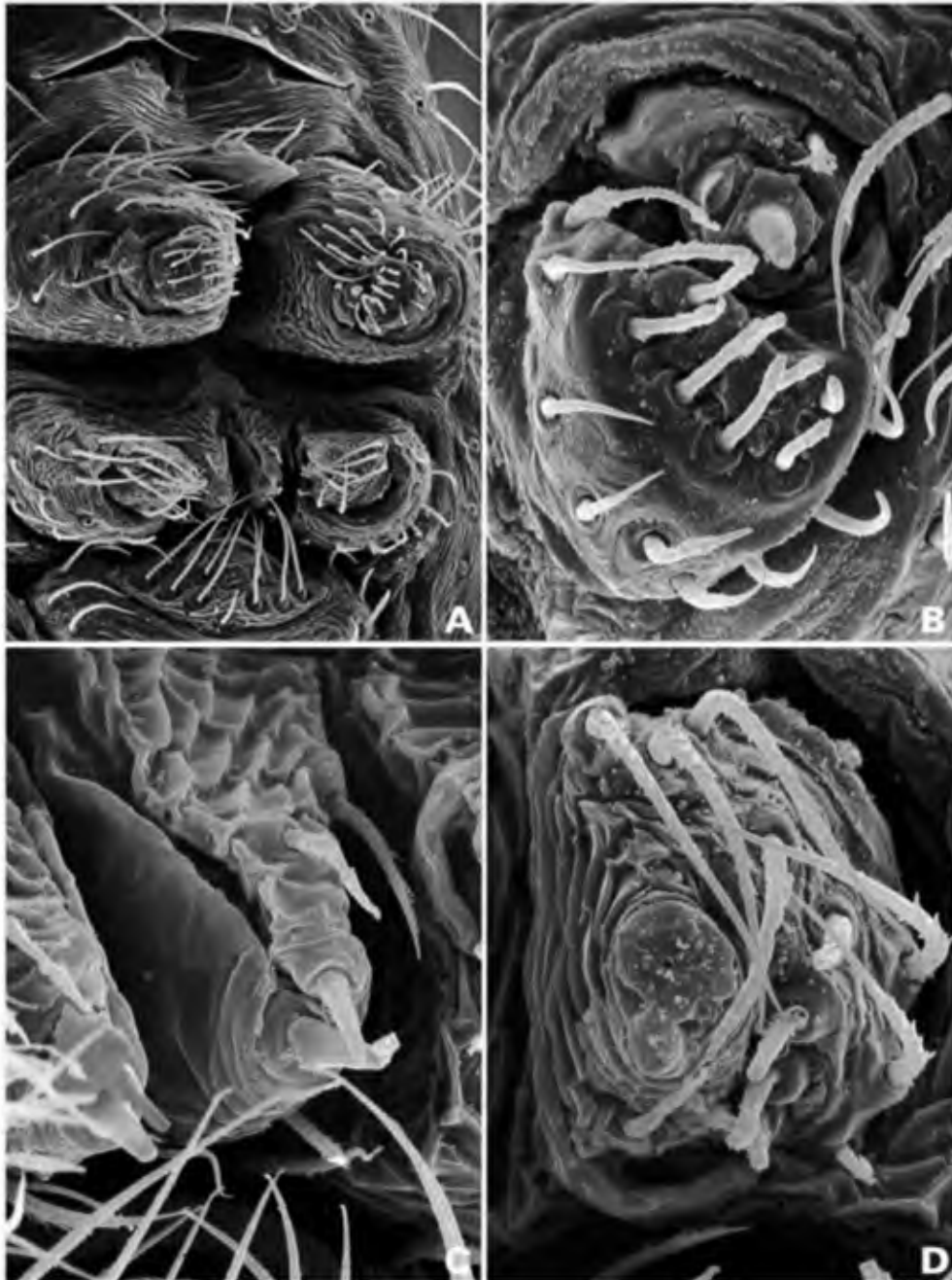

Figure 43. *Pahora murihiku*, Otago, New Zealand, male spinnerets. A, spinneret group (left). B, anterior lateral spinneret. C, posterior median spinnerets. D, posterior lateral spinneret.

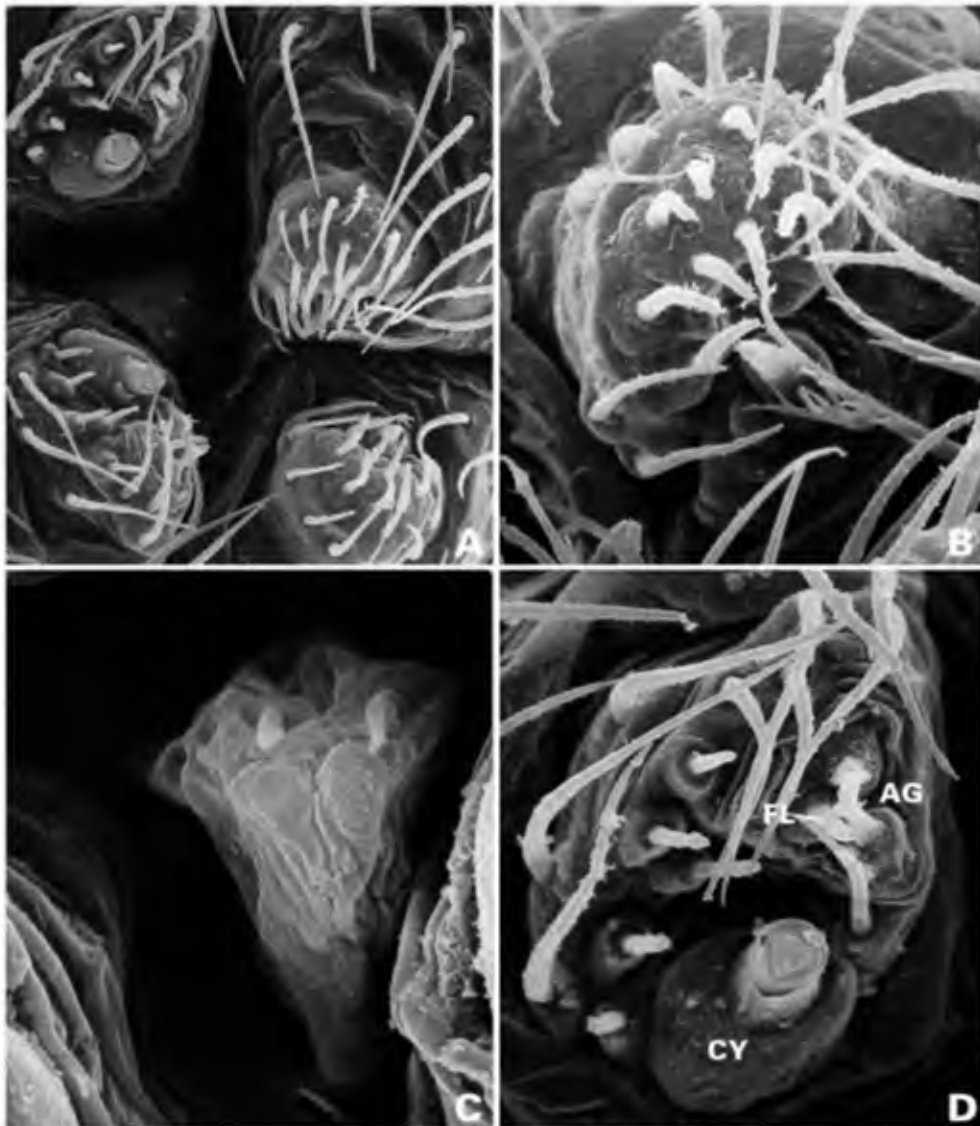

Figure 44. *Meringa otago*, Dunedin, New Zealand, female spinnerets. A, spinneret group. B, anterior lateral spinneret (right). C, posterior median spinnerets. D, posterior lateral spinneret (right).

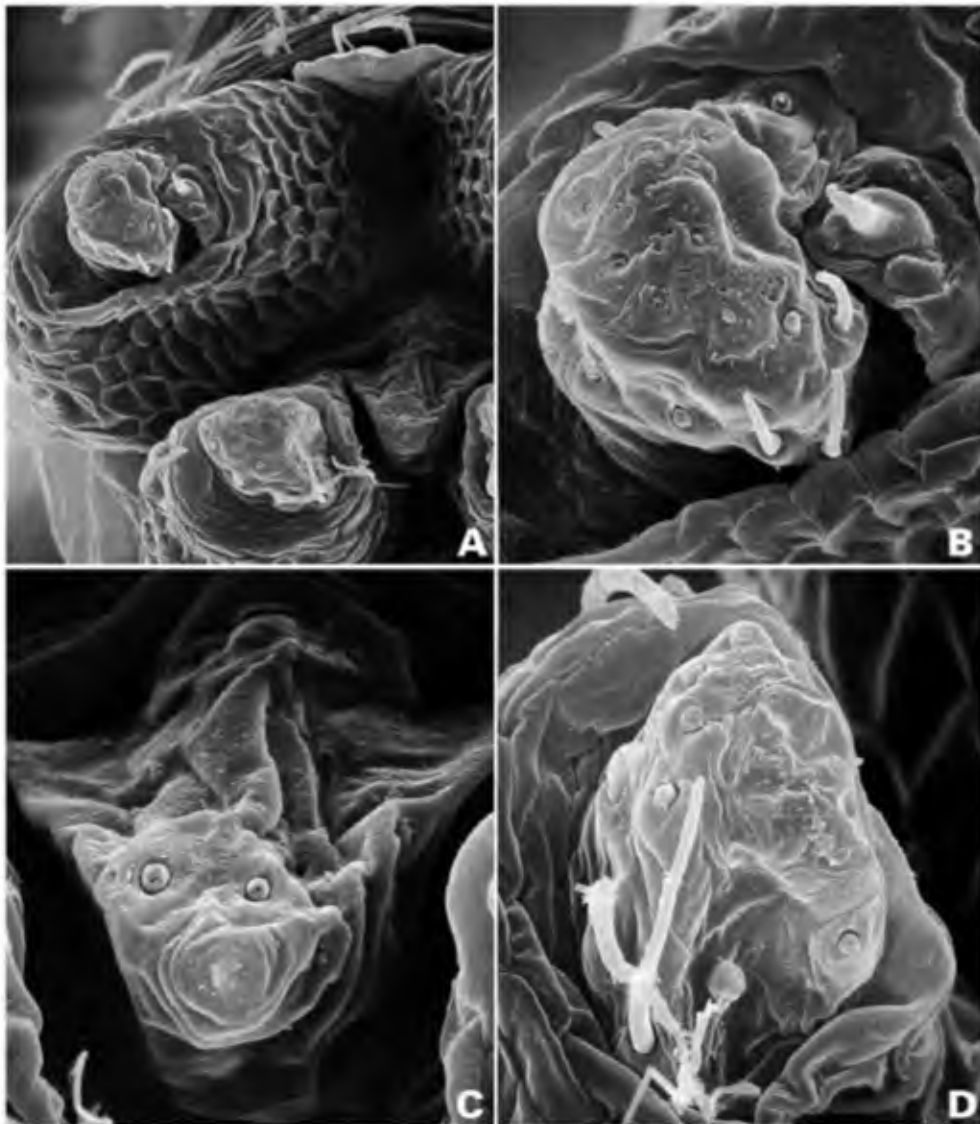

Figure 45. *Meringa otago*, Dunedin, New Zealand, male spinnerets. A, spinneret group (right). B, anterior lateral spinneret. C, posterior median spinnerets. D, posterior lateral spinneret.

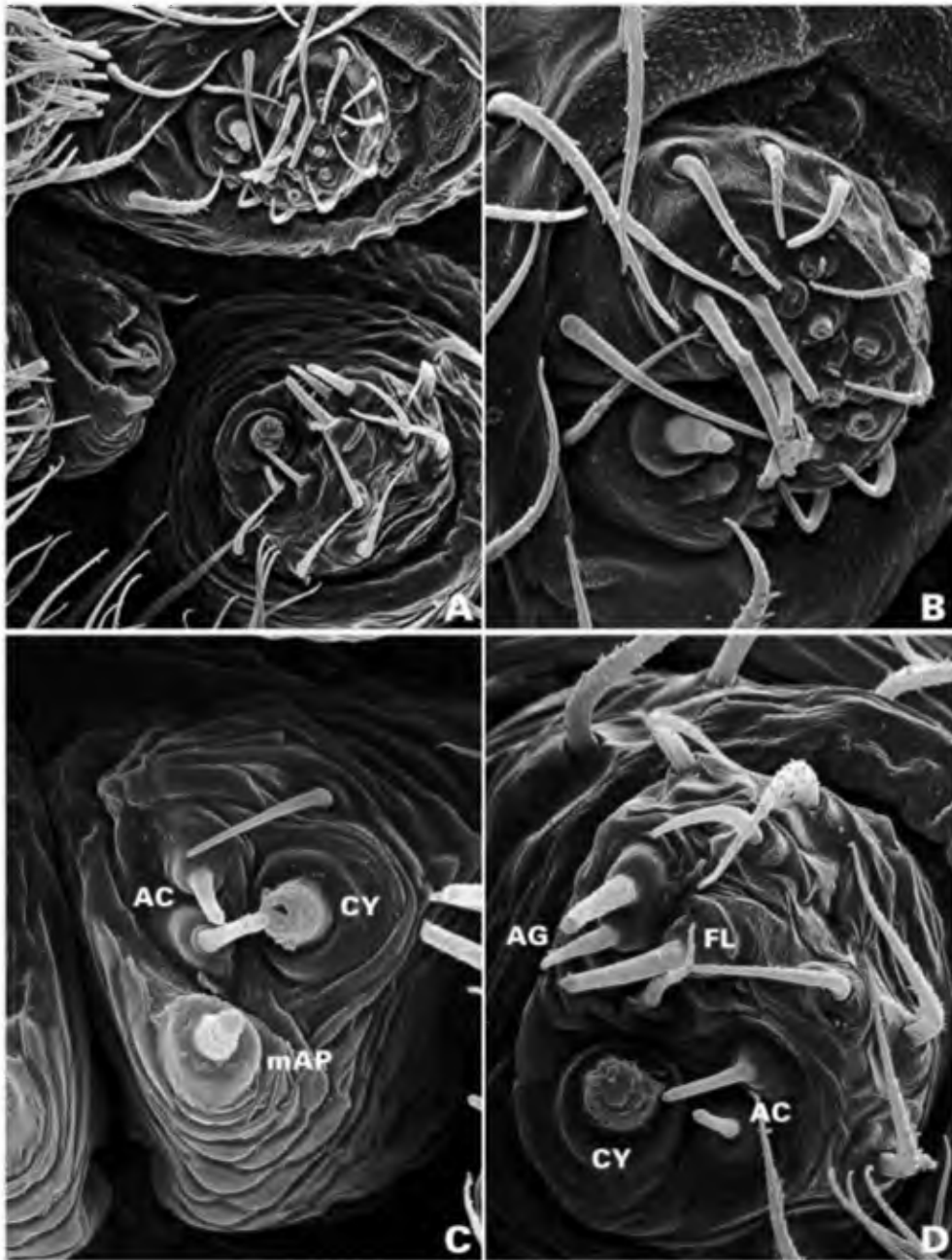

Figure 46. *Tékella absidata*, Canterbury, New Zealand, female spinnerets. A, spinneret group (left). B, anterior lateral spinneret. C, posterior median spinneret. D, posterior lateral spinneret.

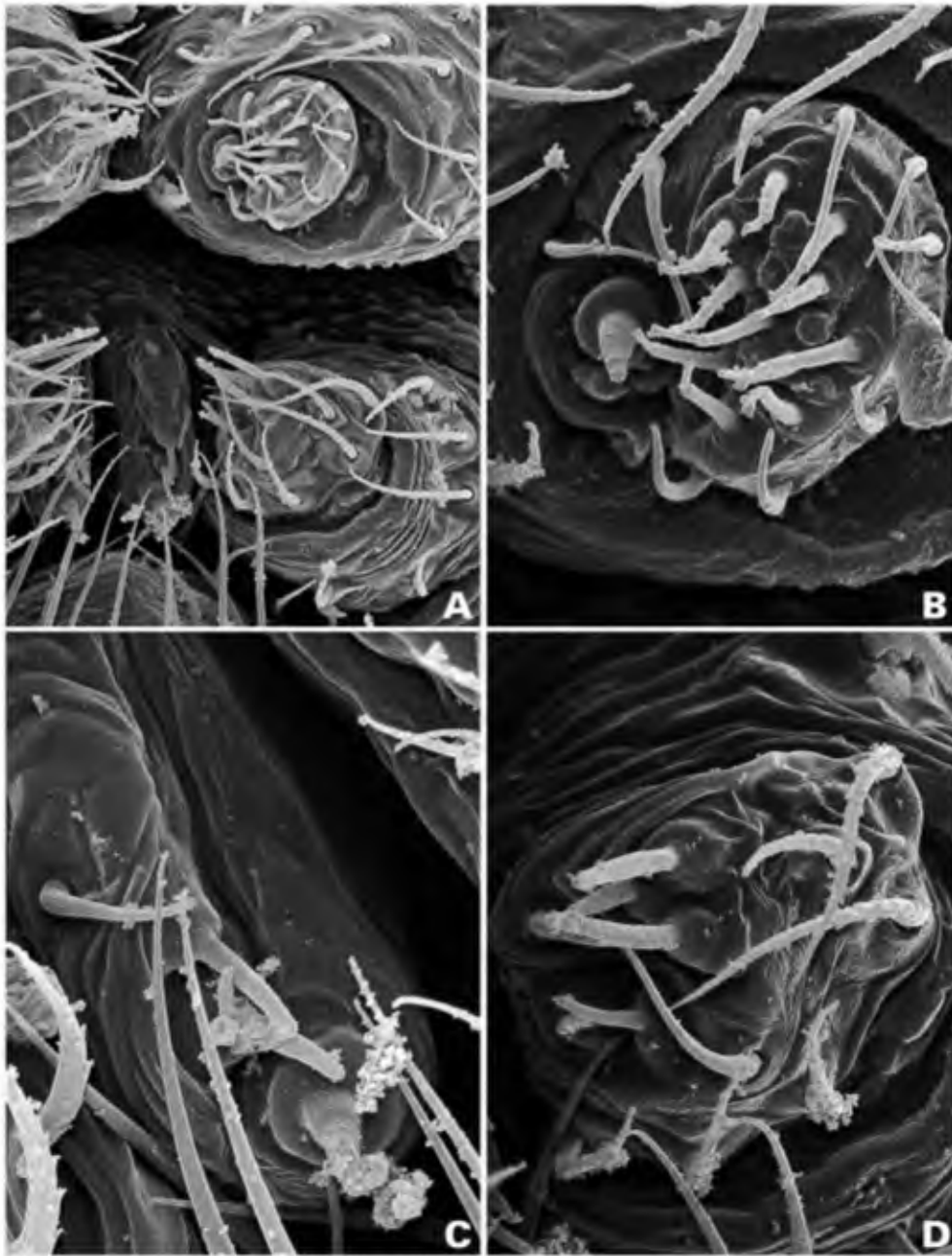

Figure 47. *Tekella absidata*, Canterbury, New Zealand, male spinnerets. A, spinneret group (left). B, anterior lateral spinneret. C, posterior median spinneret. D, posterior lateral spinneret.

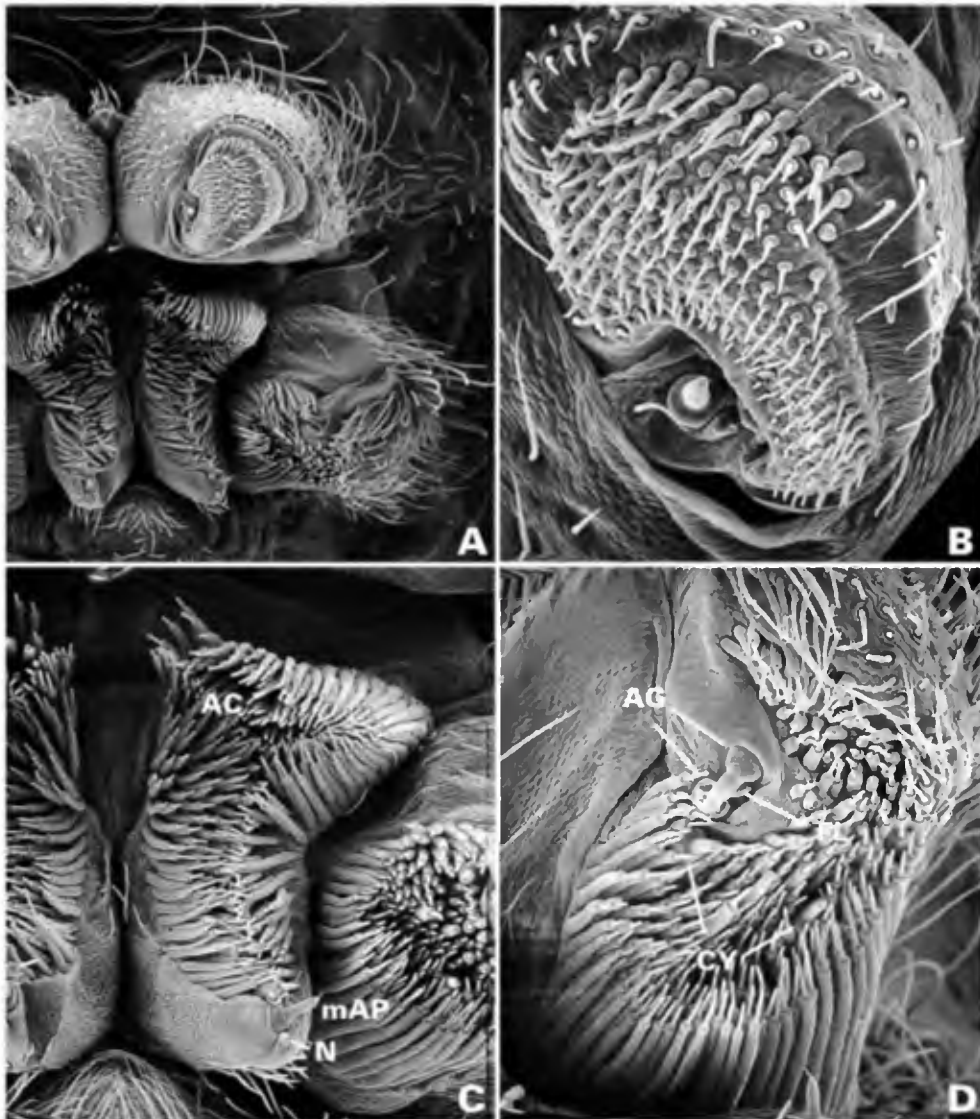

Figure 48. *Argiope argentata*, Miller's Landing, Mexico, female spinnerets. A, spinneret group (left). B, anterior lateral spinneret. C, posterior median spinneret. D, posterior lateral spinneret.