

## Greenhouse gas measurement capability at the Carbon Related Atmospheric Measurement (CRAM) Laboratory at the University of East Anglia, United Kingdom

Philip A. Wilson, Andrew C. Manning, Andrew J. Macdonald, Alex J. Etchells and Elena A. Kozlova  
School of Environmental Sciences, University of East Anglia, United Kingdom

[p.wilson1@uea.ac.uk](mailto:p.wilson1@uea.ac.uk); [a.manning@uea.ac.uk](mailto:a.manning@uea.ac.uk)

### Abstract

The new Carbon Related Atmospheric Measurement (CRAM) Laboratory, School of Environmental Sciences, University of East Anglia (UEA), United Kingdom has been equipped to make highly precise and accurate atmospheric measurements of O<sub>2</sub>, CO<sub>2</sub>, CH<sub>4</sub>, CO, N<sub>2</sub>O, SF<sub>6</sub>, and Ar/N<sub>2</sub>. The measurement system operates as a single contiguous unit, with sample air passing consecutively through four analysers. A bespoke software program controls the system and collects all data. The measurement system is designed to accommodate analyses of air from high pressure cylinders or low pressure flasks, as well as direct monitoring of outside air from inlets installed on the roof. We incorporated flexibility in our design to allow sample analyses from a wide range of flask types from our collaborators, with the only stipulation being a necessity for two valves at one end of the flask. The system is fully automated and was designed with the objectives to minimise time, labour and logistical costs, and calibration standard consumption. All analysers are routinely calibrated against a suite of 14 primary calibration standards from NOAA/ESRL and Scripps Institution of Oceanography. To support the CRAM Laboratory and our field station operations, we have also built a high pressure Cylinder Filling Facility (CFF) for preparing our own secondary calibration and working standards. Cylinders are filled with dry air to a pressure of up to 300 bar and with a dewpoint less than 1 ppm H<sub>2</sub>O. In addition, the CFF has the capability to produce a wide range of below or above ambient concentrations for all gas species listed above. We have also designed a new style of glass sampling flask. Our flask has two valves at one end which seal with PCTFE seats, one of which has a diptube extending to near the bottom of the flask. Connections are via ball and cup joints with a pinch clamp. The flask internal volume is 2.4 L and it has dimensions such that it can be used with the 'standard' NOAA shipping box, or our own cardboard boxes that hold six flasks.

### 1. Introduction

Post-industrial growth of greenhouse gas (GHG) concentrations in the atmosphere have had, and will continue to have, a profound effect on the Earth's climate. While political and public acceptance of this fact is slowly growing, there remains a need to better quantify both real-time GHG concentrations and their sources and sinks. In addition, accurate measurements of carbon dioxide (CO<sub>2</sub>) and other long-lived GHGs are very important for climate modelling and GHG emissions accounting procedures. In spite of the growing demand for, and policy-relevance of reliable atmospheric measurements, the United Kingdom lags behind other nations in making such measurements. This paper describes the establishment of a new laboratory in the UK which has been purpose-built with the goal of making high precision measurements of CO<sub>2</sub>, oxygen (O<sub>2</sub>), methane (CH<sub>4</sub>), and other greenhouse and related gases. An important objective is that this laboratory will help to establish a UK-based network of GHG measurements, extending to UK overseas territories, and will complement the existing global networks. In the long-term, this new laboratory will contribute to the scientific knowledge base needed to form defensible and enforceable policy on such an important area of Earth System Science.

The Carbon Related Atmospheric Measurement (CRAM) Laboratory and Cylinder Filling Facility (CFF), described in sections 2 and 3, support our field stations, notably Weybourne Atmospheric Observatory (WAO; 52.95°N, 1.12°E) on the central east England coast. In addition, continuous measurement of O<sub>2</sub> and CO<sub>2</sub> will soon be established at Mace Head, Ireland (53.33°N, 9.90°W), and a portable O<sub>2</sub> and CO<sub>2</sub> system will soon be deployed on a freight ship providing measurements along a latitudinal transect over the Atlantic Ocean. Flask sampling stations are being established on a number of South Atlantic islands (including Falkland Islands (51.94°S, 58.81°W) and Ascension Island (7.96°S, 14.39°W)) in collaboration with Royal Holloway, University of London. The CRAM Group has also inherited from Princeton University a flask

sampling programme conducted at Cape Point, South Africa (34.35°S, 18.49°E), in collaboration with the South African Weather Service.

## 2. The CRAM Laboratory

The CRAM Laboratory is a component of the Laboratory for Global Marine and Atmospheric Chemistry (LGMAC) in the School of Environmental Sciences at the UEA. The CRAM Laboratory is located in a small, crammed, temperature controlled room with a footprint of 30 m<sup>2</sup> (6 m x 5 m) and houses a custom-built vacuum ultraviolet (VUV) O<sub>2</sub> analyser [Stephens *et al.*, 2003; Stephens, 1999]; a *Siemens Ultramat 6F* CO<sub>2</sub> analyser; a *Perkin Elmer Clarus 500* gas chromatograph (GC) with methaniser, flame ionisation detector (FID) for measuring CH<sub>4</sub> and CO, and electron capture detector (ECD) for measuring N<sub>2</sub>O and SF<sub>6</sub>; and an *IsoPrime*<sup>TM</sup> 10-collector (28 – 46 amu channels) isotope ratio mass spectrometer for measuring Ar/N<sub>2</sub> ratios [Keeling *et al.*, 2004]. Each of these analysers can be seen labelled in Figure 1.

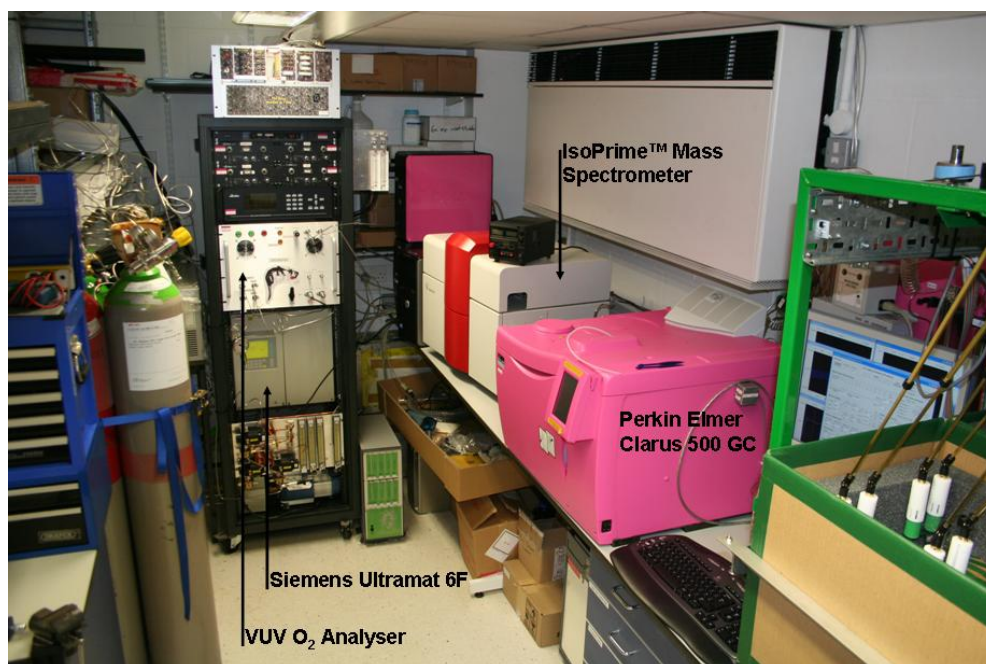

Figure 1. Photo of the CRAM Laboratory.

As shown in Figure 2, sample air, at a flowrate of 100 mL/min, passes in series through the GC ECD and FID sample loops, the CO<sub>2</sub> analyser and the VUV O<sub>2</sub> analyser (VUV xenon lamp shown in Figure 3). A very low flow of ~0.01 mL/min is siphoned off to the mass spectrometer immediately upstream of the VUV analyser cell, taking advantage of the very stable active pressure control ( $\pm 0.0005$  mbar short-term precision) and a high-speed switching mechanism (every 4 seconds). The GC carries out analyses via discrete, periodic injections of sample air onto chromatographic columns, whilst the other three analysers operate under a continuous flow regime. Despite this fundamental difference, our gas handling arrangement has been designed to simultaneously accommodate the demands of both discretised and continuous flow systems. The system has been designed in such a way that if any analyser is not in operation, the other analysers can still be used.

The CRAM Laboratory system represents the first-ever use of a *Perkin Elmer* GC for high precision GHG measurement, and only the second-ever use of a VUV analyser for O<sub>2</sub> measurement and of an *IsoPrime*<sup>TM</sup> mass spectrometer for Ar/N<sub>2</sub> ratio measurement [Keeling *et al.*, 2004; Stephens *et al.*, 2003]. The measurement of several species from a single airstream significantly reduces the time, labour, calibration standard consumption, and thus cost compared to individual species analyses.

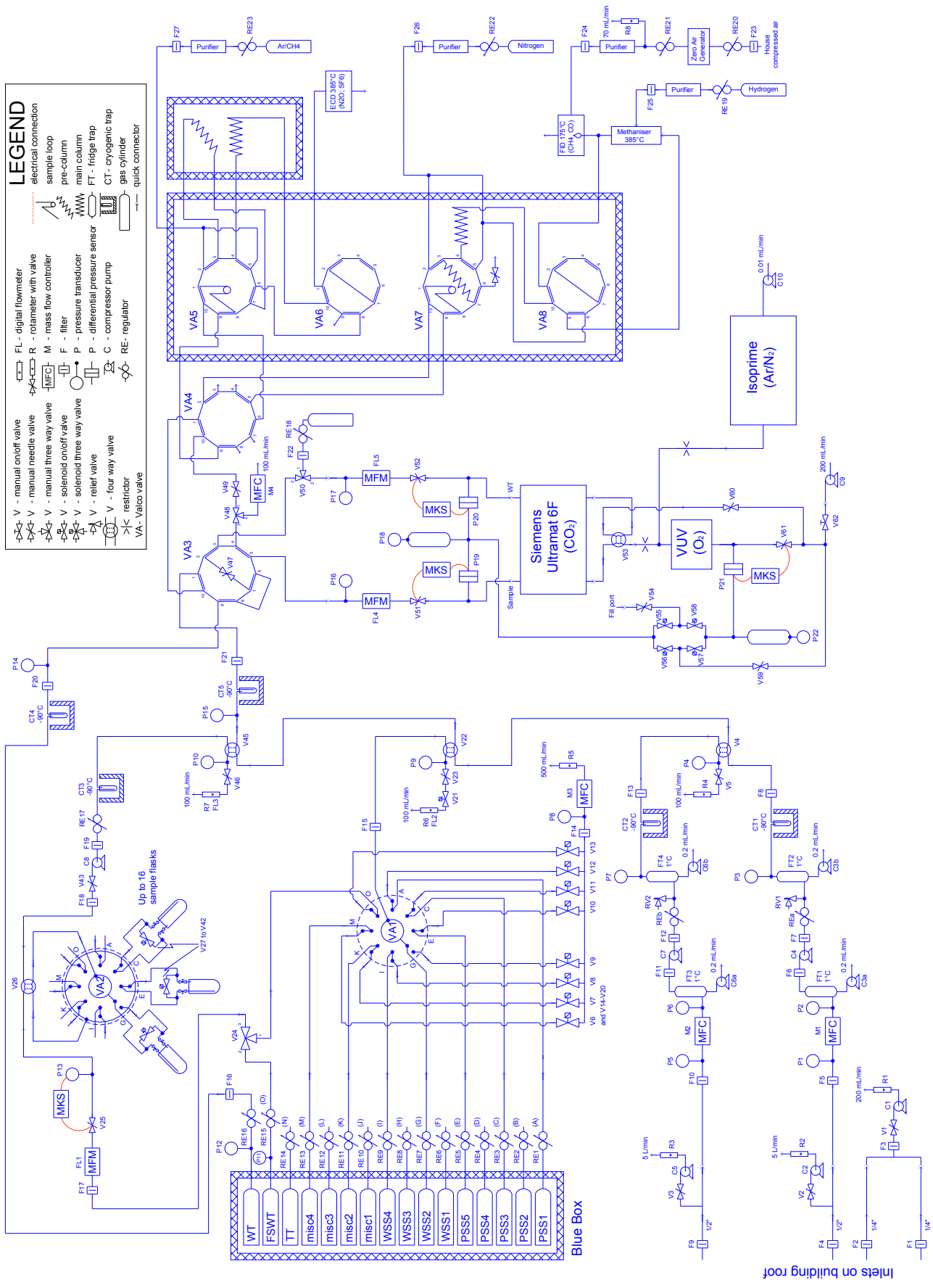
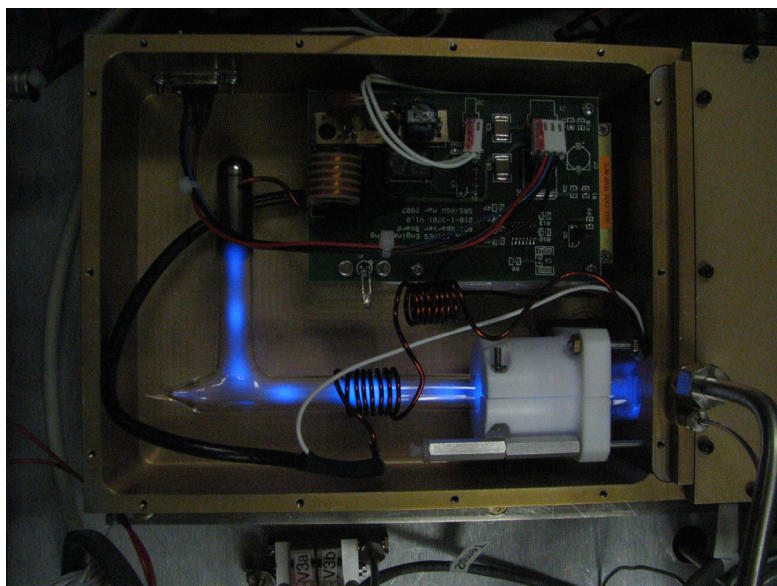

Figure 2. The CRAM Laboratory gas handling schematic. For clarity, with VA1 and VA2, only 8 of 15 and 3 of 16 gas handling arrangements of cylinders and flasks, respectively, are shown.

The CRAM Laboratory measurement system has the capability to analyse air from high pressure cylinders (middle left of Figure 2 when viewed in landscape), sample flasks (top left of Figure 2) as well as *in situ* from aspirated inlets (bottom left of Figure 2) [Blaine *et al.*, 2006] installed on the roof of the building. The system allows analyses of air from cylinders pressurised up to 300 bar, significantly higher than most comparable systems. Presently, sample flasks must be at approximately 1 bar absolute pressure, however, we intend to upgrade the system to also allow analyses from pressurised flasks, in order to be compatible with a wider range of international intercomparison programmes. Up to 16 flasks can be analysed in automated fashion via a custom-built inlet system employing 32 computer-controlled DC motors attached to telescoping arms which open the flask valves. The telescoping arms are particularly advantageous because they allow a large degree of variability in the positioning of the valves on the flask with respect to the flask body during the fabrication process. The adapters that fit over the flask valves at the end of the telescoping arms can be easily exchanged to accommodate different flask types, for example, in intercomparison exercises or joint international projects. Presently, we use adapters for our own flasks (see Figure 8) and Princeton University flasks. The only requirement stipulated for the collaborator's flasks is that they have two valves at one end of the flask. The system can accommodate a wide range of flask sizes from 0.5 L up to ~10 L.



**Figure 3. VUV xenon lamp in excited state. Sample air passes in and out of the analyser cell at a pressure of about 95 mbar via the 1/16th and 1/4 inch OD tubing, respectively, shown in the bottom right of the photo.**

Routine calibrations of all analysers are based on a suite of 14 primary calibration standards from NOAA/ESRL (the UN/WMO Central Calibration Laboratory (CCL) for CO<sub>2</sub>, CH<sub>4</sub>, and CO) and Scripps Institution of Oceanography (for O<sub>2</sub>/N<sub>2</sub> and Ar/N<sub>2</sub>). The NOAA standards have also been certified (by NOAA) for N<sub>2</sub>O and SF<sub>6</sub>. Calibration scales are maintained and propagated indefinitely via regular analyses of a hierarchical set of secondary and tertiary standards according to the methodology developed by Keeling *et al.* [1998] and expanded upon by Kozlova and Manning [2009]. All standards in use at any given time are stored horizontally in a large thermally insulated 'Blue Box', shown in Figure 4. This is a requirement for high precision O<sub>2</sub> and Ar/N<sub>2</sub> measurement, and has been also shown to result in more stable CO<sub>2</sub> concentrations in high pressure cylinders [Kozlova and Manning, 2009; Keeling *et al.*, 2007].

The measurement system is controlled by bespoke software (written in C#) that controls all valve switching, runs calibration sequences, and establishes air analyses of either suites of high pressure cylinders, flask samples, or roof air. In addition, our software collects diagnostic information from many pressure, temperature, and flow sensors (see Figure 2), and outputs ASCII

data files for subsequent data processing using IDL programs. Direct control of the GC and mass spectrometer is achieved via commercial *TotalChrom*<sup>™</sup> and *IonVantage* software, respectively, whilst our C# software receives the raw output from these packages and processes their data.

The CRAM Laboratory recently joined the 'Cucumber' ([www.cucumbers.uea.ac.uk](http://www.cucumbers.uea.ac.uk)) [Manning *et al.*, 2009] and 'GOLLUM' ([www.gollum.uea.ac.uk](http://www.gollum.uea.ac.uk)) international intercomparison programmes for GHGs and O<sub>2</sub>, respectively.



Figure 4. The CRAM Laboratory 'Blue Box'

### 3. The Cylinder Filling Facility (CFF)

In tandem with the establishment of the CRAM Laboratory, the CFF has been set up within LGMAC at UEA to support the CRAM Group's projects (Figure 5).

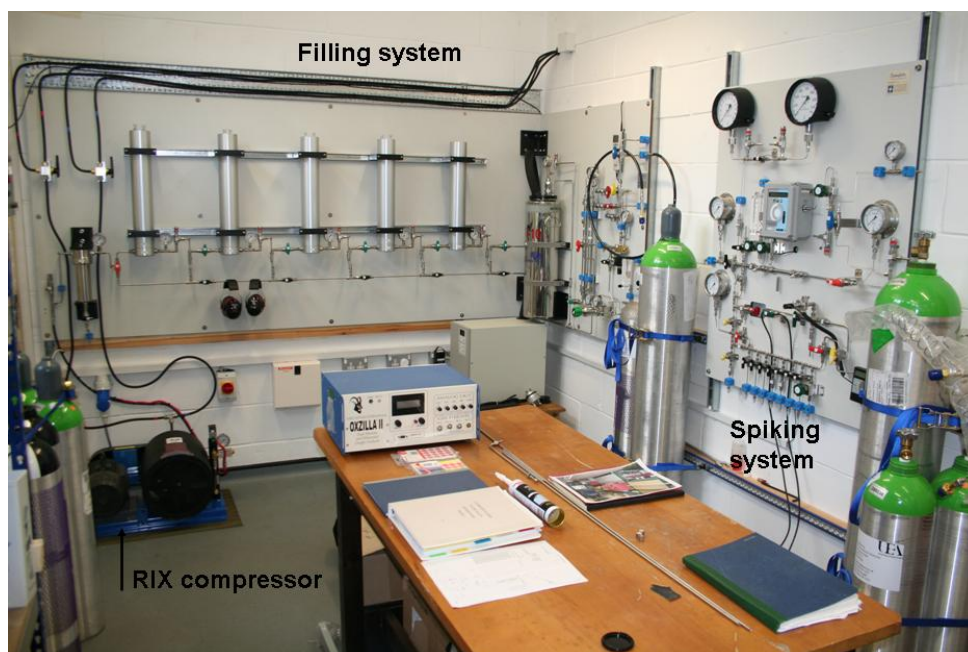
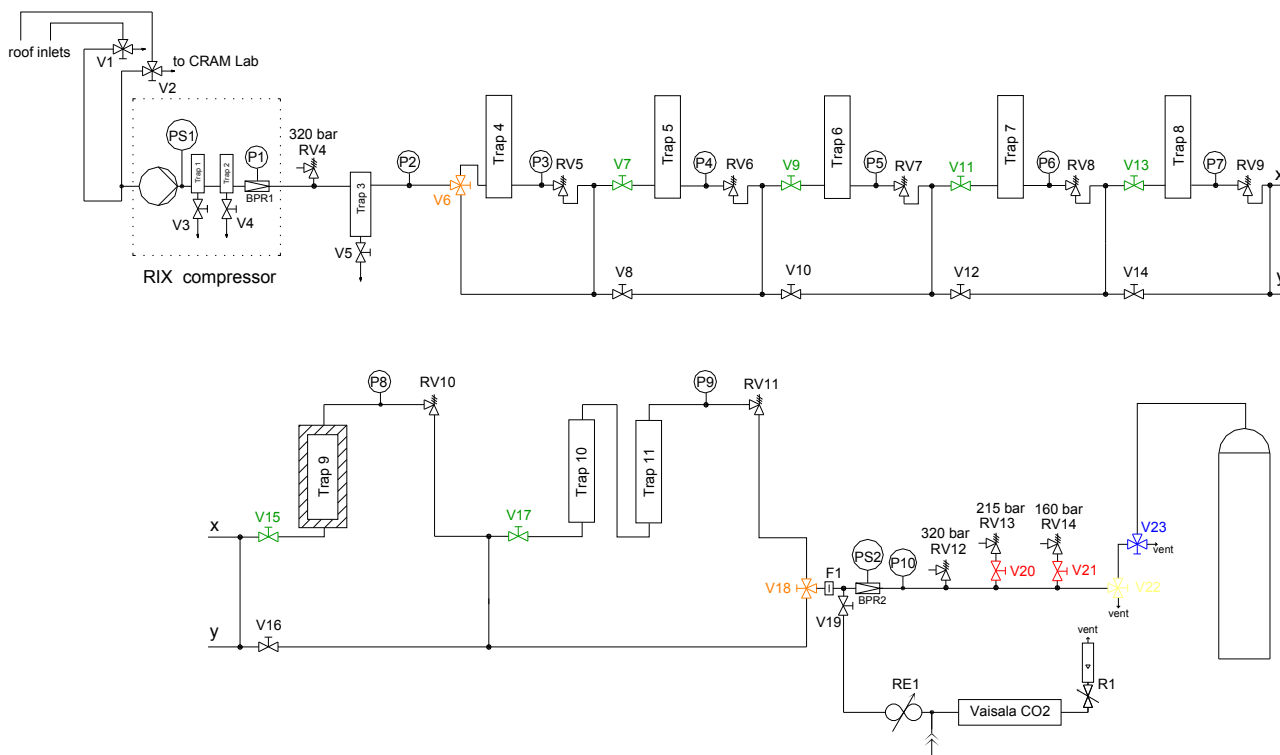

Figure 5. Photo of the CFF cylinder filling and spiking systems.

In the CFF, a *RIX Industries SA-6E* compressor is used to fill cylinders with dry air up to 300 bar pressure (typically 150-200 bar). As shown in Figure 6, air is drawn in from two inlets on the UEA roof, five floors above, by the RIX compressor and passed through condensation traps 1, 2 and 3 to remove moisture. Further drying, to less than 1 ppm H<sub>2</sub>O content, is achieved with a 3A molecular sieve trap (trap 4), and two anhydrous magnesium perchlorate traps (traps 10 and 11). Five additional chemical traps (traps 5 to 9) allow the selective scrubbing of the greenhouse and trace gases of interest to provide sub-ambient concentrations. Shown in Figure 6, our plumbing design allows each of these traps to be individually used or bypassed as required during filling to achieve the required concentrations of gases. The placement of in-line relief valves after each trap allows the compressor to build up pressure in the trap to achieve optimal and reproducible scrubbing capacity whilst avoiding the potential for outgassing of previously captured gases. Trap 9 can be cooled progressively down to -100°C in a cryogenic bath for improved chemical absorption characteristics. CO<sub>2</sub> is monitored during filling with a small portion of the air flow directed to a *Vaisala CARBOCAP Carbon Dioxide Probe GMP343* just before the final pressure gauges and safety relief valves shown in Figure 6. We have three certified safety relief valves (RV12, RV13, RV14 in Figure 6) so that appropriate safety measures can be taken depending on the pressure rating of the vessel being filled. We also employ two electronic pressure switches (PS1, PS2 in Figure 6) which will shut the compressor off at user-defined setpoints.



**Figure 6. The CFF cylinder filling gas handling schematic.**

While the trap system described above provides below ambient concentrations, a spiking system can provide above ambient concentrations after a cylinder is filled. A filled cylinder can be 'spiked' with up to nine gas species (O<sub>2</sub>, N<sub>2</sub>, Ar, CO<sub>2</sub>, CH<sub>4</sub>, H<sub>2</sub>, N<sub>2</sub>O, CO, SF<sub>6</sub>). These are shown in Figure 7 as a suite of nine cylinders, which can each be used to fill a calibrated volume to a pre-calculated pressure. The pressure is set via one of two high-precision pressure gauges (P6, P7 in Figure 7). This gas is then 'pushed' into the 'spike / dew cylinder' with a short burst of pressurised air from the 'push cylinder' (connected to the opposite end of the calibrated volume). To mitigate the possibility of explosion hazards, all parts of the system that could come into contact with pure O<sub>2</sub> have been carefully 'oxygen-cleaned' (shown in red in Figure 7). After allowing a suitable period for mixing, the cylinder is reanalysed in the CRAM Laboratory.

The spiking panel performs two additional tasks. Every new cylinder must be thoroughly evacuated to remove the room air and any moisture adsorbed on the inner walls during the manufacturing process. Two vacuum pumps are used to evacuate the cylinder labelled 'Evac cylinder' in Figure 7. A *Thomas 107CGH18* pump (VP1 in Figure 7) is used as a 'coarse' pump for 20 mins followed by a 24 to 48 hr evacuation with a 'fine' pump (VP2; *KNF Neuberger Inc., N813.4ANE*). The second additional task is measuring the dewpoint of a recently filled cylinder. A *Meeco Inc. Accupoint 2* moisture meter is used for this task. A 'dry purge air' cylinder is used to flush the tubing and dewpoint meter before use, thus consuming only a small amount of air in the 'spike / dew cylinder'.

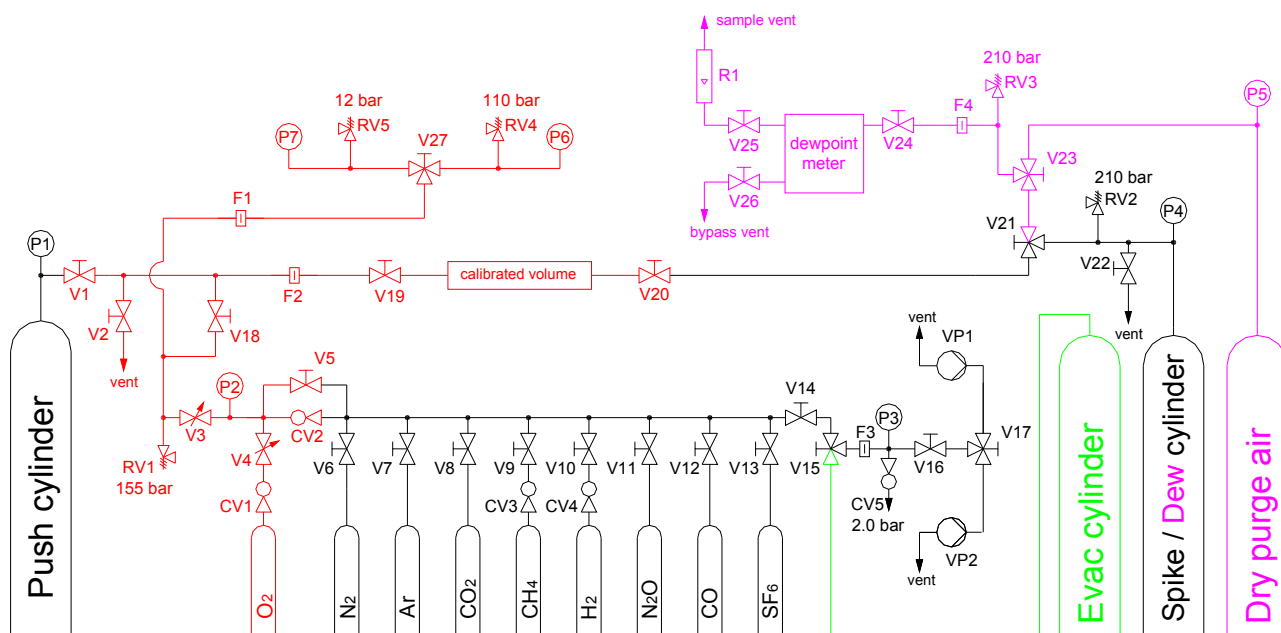

Figure 7. The CFF spiking system gas handling schematic.

#### 4. The UEA flask

We have designed a new glass sampling flask (Figure 8), after an iterative process fabricating and assessing several prototypes. The new flask design drew on years of experience working with many different glass flasks from many of our colleagues. The end result, we hope, is a flask that incorporates almost all of the benefits of the various other flask designs, whilst attempting to eliminate most of their weaknesses. The UEA flask has been optimised for the specific suite of gas species which we will analyse in the CRAM Laboratory and thus is not necessarily the optimum design for other atmospheric applications.

The UEA flask has two valves, both placed at one end, one of which has a diptube extending to near the bottom of the flask. We use two valves to avoid the necessity of using evacuated flasks when collecting samples, since some species such as O<sub>2</sub> have been shown to be sensitive to any pressure changes during sampling. The diptube alongside the interior wall of the flask is attached to the wall near the bottom end for improved strength, and is bent towards the centre of the flask at the bottom end; this latter feature is to facilitate better flask flushing characteristics. The flask has a rounded bottom to improve flushing and to give greater strength.

Placing both valves at one end provides several important advantages, including:

- field collection of the sample and laboratory analyses can be carried out without removing the flask from the shipping box, which significantly reduces labour and logistical costs, minimises space and storage requirements (particularly important in the field), and increases safety owing to reduced risk of glass breakage from less handling. In addition, keeping the flask in the

shipping box protects the sample against UV exposure, without requiring a covering over the glass;

- a significantly larger flask sample volume is achieved for a given shipping box size, which reduces shipping costs and facilitates box handling. Over the longer-term, shipping costs are the major costs of operating flask sampling programmes. Larger sample volume also allows for more gas species to be measured from the collected samples;
- improved strength and robustness of the flask. Glass flasks mostly break at the point where the glass valve meets the body of the flask, or at the valve itself. With both valves at one end, only one side of the flask need be considered the weak side. This allows for much simpler, lower-cost shipping boxes to be designed, and ultimately results in fewer flask breakages and consequently fewer lost samples.
- finally, flask analysis racks in the laboratory can be more easily and simply constructed if both valves are at one end.



**Figure 8. The UEA Flask**

The UEA flask valves are high vacuum spindle valves (model SPV 3, *Normag Labor und Prozesstechnik GmbH*) that seal with PCTFE (Kel-F) seats. From a range of options, these seats have been found to result in the most stable concentrations inside the flask for the range of species of our interest [*Sturm et al.*, 2004]. Flask connections are via ball and cup joints (size 18/9; *ChemGlass Inc.*; formerly *J. Young Co.*), with a Viton o-ring on the ball, and with a pinch clamp and thumbscrew to hold them together. Each flask has one ball and one cup joint, so that inlet and outlet can not be confused. The ball and cup joints are oriented in the same plane as the flask body, for ease of access without removing the flask from the shipping box. Two glass rods connect the joints to each other and to the flask body for increased strength and support.

The UEA flask has an internal volume of 2.4 L. The dimensions of the flask make it compatible with the NOAA/ESRL 'standard' shipping box (which holds four flasks), but we have designed our own shipping box to accommodate six flasks. This provides additional options for routine flask sampling, for example, allowing either two triplicate or three duplicate samples to be collected with one box. The shipping box was designed to be small and lightweight enough to be easily handled by one person (10 kg when filled). The box is made from double-walled, stitched cardboard (300 KTBC; *Davpack Paper Co. Ltd.*), with edges covered with waterproof cloth adhesive tape. The cardboard has a double layer of water-resistant coating, and 'full flaps' on two sides that allow a field station mailing address on one flap and the laboratory address on the other. 50 mm thick foam surrounds all internal walls of the box, as well as in between flasks (S275 foam; *Davpack Paper Co. Ltd.*). Foam type was chosen to optimise both impact absorption and cushioning. A cardboard insert is used to prevent the flask bodies from moving vertically within the box, and to prevent the valves from having any contact with the foam or walls of the box. Elimination of pressure points on the valves in such a manner greatly reduces the likelihood of breakages. A filled box was tested with multiple drops from 1.5 m height onto a concrete floor.

In choosing connectors for our flasks, we avoided the sometimes-used *Swagelok Ultra-Torr™* connectors since they can grind against the glass, producing glass fragments that then cause leaks at the valve seat. In addition, *Ultra-Torr™* connectors are not designed for positive pressure applications, and they have been known to blow off the flask when collecting samples at positive pressure, even with pressures as low as 0.7 barg. In the case of sample collection for O<sub>2</sub> or Ar/N<sub>2</sub> analysis, this issue is even more important: one can not simply re-connect the *Ultra-Torr™* and resume flushing, because O<sub>2</sub> and Ar/N<sub>2</sub> artefacts are introduced into the sample whenever the interior flask walls experience a change in pressure. We tested *ChemGlass Inc.* screw-thread



connectors (part # CG-350-01) mated to Synflex 1300 tubing, but we found attaching the Synflex tubing to the screw-thread connectors to be 'fiddly'. In addition, with repeated use of Synflex tubing with these connectors, leaks can occur as the tubing becomes deformed by the o-ring inside the screw-thread connector (B. Stephens, NOAA USA and NIWA NZ, pers. comm.). Finally, with both *Swagelok* Ultra-Torr™ and *ChemGlass* screw-thread connectors, it is possible to mix up the inlet and outlet of the flask.

In choosing the volume of the UEA flask, we decided to avoid the large flask size of 5 L used by Scripps Institution of Oceanography to reduce shipping costs and storage space requirements, but at the same time we considered 1 L flasks to be too small. Other workers choose small flask volumes and compensate this by pressurising the flask, for example to 1 or 2 barg. However, it has become apparent from two decades of O<sub>2</sub> flask analyses that many sample collection and storage problems and artefacts can be avoided simply by filling flasks only to ambient pressure. This constraint is even more applicable to Ar/N<sub>2</sub> measurement. Viton o-ring seals at the valve seats would likely have been sufficient for ambient pressure samples, but PCTFE seats allow us additional flexibility to collect pressurised samples.

A wax-coating finish on the cardboard boxes (as used by Scripps and NOAA/ESRL) would have been preferable compared to our double coating of a water-resistant finish, but we were unable to find a UK supplier providing wax coatings. Shipping boxes made from cardboard are an order of magnitude cheaper and much lighter than aluminium boxes used by some colleagues. Experiences of NOAA and Scripps suggest that cardboard boxes have a lifetime of 10-15 years, even when used in hostile environments. A key strategy to realising this lifetime potential is liberal coverage and repair of boxes with a strong waterproof cloth adhesive tape.

## 5. Acknowledgements

We thank B. Stephens, S. Shertz and A. Watt (NCAR, USA) for a great deal of assistance and advice building the VUV O<sub>2</sub> analyser; G. Johnson (Perkin Elmer, UK) for help optimising the GC; J. Hewitt (Swagelok London, UK) for advice building the CFF systems; R. Keeling, B. Paplawsky and A. Cox (Scripps, USA) for collaboration with O<sub>2</sub> measurement, flask design and high pressure cylinder filling design; M. Myles for advice on glassblowing and fabricating several prototype sampling flasks; and S. Rix, D. Blomfield, N. Griffin, and R. Humphrey (UEA/ENV) for technical and electronics assistance. We are also very grateful to Ernst Brunke (South African Weather Service) and Gerry Spain (National University of Ireland, Galway, Ireland) for assistance establishing our Cape Point and Mace Head sampling programmes, respectively. A. C. Manning is supported by a UK NERC/QUEST Advanced Fellowship (Ref. No. NE/C002504/1); P. A. Wilson's Ph.D. Studentship is funded by NERC Grant No. NE/F005733/1.

## 6. References

- Blaine, T. W., R. F. Keeling, and W. J. Paplawsky, An improved inlet for precisely measuring the atmospheric Ar/N<sub>2</sub> ratio, *Atmospheric Chemistry and Physics*, 6, 1181-1184, 2006.
- Keeling, R. F., T. Blaine, B. Paplawsky, L. Katz, C. Atwood, and T. Brockwell, Measurement of changes in atmospheric Ar/N<sub>2</sub> ratio using a rapid-switching, single-capillary mass spectrometer system, *Tellus Series B-Chemical and Physical Meteorology*, 56 (4), 322-338, 2004.
- Keeling, R. F., A. C. Manning, E. M. McEvoy, and S. R. Shertz, Methods for measuring changes in atmospheric O<sub>2</sub> concentration and their application in southern hemisphere air, *Journal of Geophysical Research-Atmospheres*, 103 (D3), 3381-3397, 1998.
- Keeling, R. F., A. C. Manning, W. J. Paplawsky, and A. C. Cox, On the long-term stability of reference gases for atmospheric O<sub>2</sub>/N<sub>2</sub> and CO<sub>2</sub> measurements, *Tellus Series B-Chemical and Physical Meteorology*, 59 (1), 3-14, 2007.
- Kozlova, E. A., and A. C. Manning, Methodology and calibration for continuous measurements of biogeochemical trace gas and O<sub>2</sub> concentrations from a 300-m tall tower in central Siberia, *Atmos. Meas. Tech.*, 2 (1), 205-220, 2009.
- Manning, A. C., A. Jordan, I. Levin, M. Schmidt, R. E. M. Neubert, A. Etchells, B. Steinberg, P. Ciais, T. Aalto, F. Apadula, W. A. Brand, M. Delmotte, A. Giorgio di Sarra, B. Hall, L. Haszpra, L. Huang, D. Kitzis, S. van der Laan, R. L. Langenfelds, M. Leuenberger, A. Lindroth, T. Machida, F. Meinhardt, J.

- Moncrieff, J. A. Morguí, J. Necki, M. Patecki, E. Popa, L. Ries, K. Rozanski, R. Santaguida, L. P. Steele, J. Strom, Y. Tohjima, R. L. Thompson, A. T. Vermeulen, F. Vogel, and D. E. Worthy, Final report on CarboEurope 'Cucumber' intercomparison programme, [http://cucumbers.webapp2.uea.ac.uk/documents/CucumberFinalReport\\_Final.pdf](http://cucumbers.webapp2.uea.ac.uk/documents/CucumberFinalReport_Final.pdf), 2009.
- Stephens, B. B., Field-based atmospheric oxygen measurements and the ocean carbon cycle, Ph.D. thesis, University of California, San Diego, La Jolla, California, U.S.A., 1999.
- Stephens, B. B., R. F. Keeling, and W. J. Paplawsky, Shipboard measurements of atmospheric oxygen using a vacuum-ultraviolet absorption technique, *Tellus Series B-Chemical and Physical Meteorology*, 55 (4), 857-878, 2003.
- Sturm, P., M. Leuenberger, C. Sirignano, R. E. M. Neubert, H. A. J. Meijer, R. Langenfelds, W. A. Brand, and Y. Tohjima, Permeation of atmospheric gases through polymer O-rings used in flasks for air sampling, *Journal of Geophysical Research-Atmospheres*, 109 (D4), D04309, doi:04310.01029/02003JD004073, 2004.