

# **MODELLING OF TWIN-AXES TABLE DRIVE SYSTEM**

**LIM VUN HAW**

**BACHELOR OF MECHATRONICS ENGINEERING**

**UNIVERSITI TEKNIKAL MALAYSIA MELAKA**

“I hereby declare that I have read through this report entitled “ Modelling of Twin-Axes Table Drive System” and found that it complies the partial fulfilment for awarding the degree of Bachelor of Mechatronics Engineering”.

Signature : \_\_\_\_\_

Supervisor's Name : \_\_\_\_\_

Date : \_\_\_\_\_

**MODELLING OF TWIN-AXES TABLE DRIVE SYSTEM**

**LIM VUN HAW**

**A report submitted in partial fulfilment of the requirements for the degree of**

**Mechatronics Engineering**

**Faculty of Electric Engineering**

**UNIVERSITI TEKNIKAL MALAYSIA MELAKA**

**2017/2018**

I declare that this report entitled “Modelling of Twin-Axes Table Drive System” is the result of my own research except as cited in the references. The report has not been accepted for any degree and is not concurrently submitted in candidature of any other degree.

Signature : \_\_\_\_\_

Name : \_\_\_\_\_

Date : \_\_\_\_\_

To my beloved mother and father

## ACKNOWLEDGEMENT

First and foremost, I wish to express my greatest appreciation and deepest gratitude to my supervisor, AINAIN NUR BINTI HANAFI for constantly guiding and encouraging me throughout the entirety of this final year project. Thank you for giving me valuable advice and suggestion to bring this report to its final form. Without her support and interest, this report would not have been the same as presented here. I am very grateful for her patience and constructive comments that enriched this FYP.

I am also grateful to PROFESSOR MADYA DR. CHONG SHIN HORNG, for her provision of expertise in the implementation. She guided me throughout the implementation process from designing, fabrication until implementation. Improvements are done on the all the stages to obtain a better performance by looked into details the overlooked matters. Without her superior knowledge and experience, the FYP project wouldn't like in quality of outcomes.

In particular, my sincerely gratitude is also extends to all of my friends for their generous efforts and assistances provided in enlightening me. Their views and tips are useful indeed. I would like to acknowledge their comments and suggestions, which was crucial for the successful completion of this project. Also, I would take this opportunity to express my gratitude to my parent for their continuous shower of love, unceasing encouragement and support throughout all these years.

Last but not least, I place on record, my sense of gratitude to one and all who, directly or indirectly, have offered their helping hand during the entire period of final year project.

## ABSTRACT

Table Drive System is commonly used in industrial sectors to transfer load from one place to another place. As load weight increases, different types of tables actuated by a number of motors are developed to sustain the increase in workload. Twin-axes Table Drive System (TTDS) is constructed in this report. The TTDS has two similar units of single axis ball screw jointed together with a large mover. Two DC servo motors produce input torque with rotary motion to the TTDS. This report is also presented system modelling technique for twin axes table drive system through simulation. The table of two ball screws and motors are attached with an aluminium bar where each end of the bar is attached firmly to the slide mover. This configuration aims to sustain the increase in weight to be driven. However, synchronization of two coupled parallel ball screws is a major problem. The block diagram of the twin axes table drive system (TTDS) is constructed from past research. Hence, system identification technique is performed to construct mathematical model of the twin axes table drive system via frequency response through simulation. The transfer function obtained can present the simulated system. The performance of the twin axes table drive system is compared to the single axis ball screw table in term of load weight to be driven using Simscape. Result showed that the TTDS has better performance for 2 kg to 10kg load as compared to single axis ball screw system.

## ABSTRAK

Sistem Pemanduan Meja lazimnya digunakan dalam sektor industri untuk memindahkan beban dari satu tempat ke tempat lain. Dengan peningkatan berat beban, pelbagai jenis pemanduan meja yang beroperasi dengan motor dibangunkan bagi menyokong peningkatan beban kerja. Sistem Pemacu Meja Kapak Kembar (TTDS) dibina dalam laporan ini. TTDS mempunyai dua unit serupa paksi bola paksi tunggal bersatu bersama penggerak besar. Dua motor servo DC menghasilkan tork masukkan dengan gerakan putar pada TTDS. Laporan ini juga memperkenalkan prosedur sistem identifikasi untuk TTDS melalui simulasi. TTDS yang mengandungi dua motor dan dua unit skru bola telah dilampirkan dengan bar aluminium di tepi meja pergerakan. Konfigurasi ini mampu meningkatkan keupayaan TTDS untuk mengangkat beban yang lebih berat. Akan tetapi, masalah bersegiarah masih menjadi masalah besar untuk TTDS. Oleh itu, teknik sistem identifikasi diaplikasikan untuk mendapatkan fungsi pemindahan TTDS melalui simulasi. Rangkap pindah yang diperoleh dapat memberikan melaksanakan fungsi yang serupa dengan sistem rujukan. Pelaksanaan antara TTDS dengan sistem pemacu meja satu paksi dibandingkan dengan mengikat beban yang berlainan melalui Simscape. Keputusan menunjukkan bahawa TTDS mempunyai pelaksanaan yang lebih baik daripada sistem pemacu meja satu paksi bagi 2 kg sehingga 10 kg beban.



## TABLE OF CONTENTS

CHAPTER	TITLE	PAGE
	<b>ACKNOWLEDGEMENT</b>	<b>v</b>
	<b>ABSTRACT</b>	<b>VI</b>
	<b>TABLE OF CONTENTS</b>	<b>VIII</b>
	<b>LIST OF TABLES</b>	<b>XI</b>
	<b>LIST OF FIGURES</b>	<b>XII</b>
	<b>LIST OF APPENDICES</b>	<b>XV</b>
<b>1</b>	<b>INTRODUCTION</b>	<b>1</b>
	1.1 Overview	1
	1.2 Motivation	1
	1.3 Problem Statement	2
	1.4 Objectives	3
	1.5 Scope	3
	1.6 Report Outline	3
<b>2</b>	<b>LITERATURE REVIEW</b>	<b>5</b>
	2.1 Overview	5
	2.2 Twin-Axes Table Drive System	5
	2.2.1 Ball screw driven stage	6
	2.2.2 Linear Motor Drive Stage	8
	2.2.3 Single Axis Controller Design	11
	2.2.4 Synchronous Motion Control	12
	2.2.5 Summary	15
	2.3 Mathematical Modelling	15
	2.3.1 Lumped model	16
	2.3.2 Friction model	19
	2.3.3 Hybrid model	20

	2.3.4 Summary	21
	2.4 Frequency Response	21
<b>3</b>	<b>METHODOLOGY</b>	<b>23</b>
	3.1 Introduction	23
	3.2 Project Flow Chart	24
	3.3 Project Methodology Flow Chart	25
	3.4 TTDS Component Description	26
	3.4.1 TTDS Base Structure	26
	3.4.2 Linear Guide and Mover	26
	3.4.3 Linear Motion Actuator	27
	3.4.4 Linear Encoder	28
	3.6 Hardware Simulation and Analysis	29
	3.6.1 TTDS Hardware design	29
	3.6.2 Mover Stress Simulation	30
	3.7 System Modelling	30
	3.7.1 Past Research	31
	3.7.2 Simulated System	33
	3.7.3 Modelling of Coupled System	34
	3.8 Physical Modelling of TTDS	36
<b>4</b>	<b>RESULT AND DISCUSSION</b>	<b>38</b>
	4.1 Overview	38
	4.2 SolidWorks Analysis	38
	4.2.1 TTDS Hardware Design	38
	4.2.2 Stress and Strain Analysis	40
	4.3 System Modelling	41
	4.4 Physical Modelling	44
	4.5 Summary	46
<b>5</b>	<b>CONCLUSION AND FUTURE WORK</b>	<b>47</b>
	5.1 Conclusion	47
	5.2 Future Work	48

<b>REFERENCES</b>	<b>49</b>
<b>APPENDICES</b>	<b>54</b>

**LIST OF TABLES**

<b>TABLE</b>	<b>TITLE</b>	<b>PAGE</b>
3.1	Specification	27
3.2	Parameters of the DC servo motor	32
3.3	Parameter of lumped model ball screw drive table	34
4.1	Result of stress test	40
4.2	Transient response of TTDS and single ball screw system	45

## LIST OF FIGURES

FIGURE	TITLE	PAGE
1.1	Manufacturing and Services as Engines of Growth	1
2.1	Single ball screw drive stage	6
2.2	Twin ball screw drive system	7
2.3	Parallel ball screw drive system	7
2.4	Twin linear motor drive system	8
2.5	Structural similarity of linear motor to rotary motor	8
2.6	Linear mechanism	9
2.7	PDOP controller	12
2.8	Cross-coupling motion control system	12
2.9	Master-slave motion control system	13
2.10	Relative stiffness motion control system	13
2.11	Free body diagram of ball screw diagram	16
2.12	Block Diagram of ball screw mechanism	17
2.13	Free Body Diagram of Single Axis Ball Screw Mechanism	17
2.14	Block Diagram of Single Axis Ball Screw Mechanism	17
2.15	Block Diagram of Twin Axis Ball Screw Mechanism	18
2.16	Procedure of Identification	19
2.17	Hybrid model of ball screw drive	21
3.1	TTDS project flow	24
3.2	TTDS project methodology flowchart	25
3.3	TTDS base structure	26
3.4	Linear guide and mover	26
3.5	DC servo motor RS-263-6011	27
3.6	Ball screw	28
3.7	Single unit ball screw system	28
3.8	Linear encoder readhead RGH22A	29
3.9	Specification of RGH22A	29

3.10	Single axis ball screw system	31
3.11	Block diagram of single axis ball screw system	32
3.12	Block diagram of the reference system of TTDS	33
3.13	Second order ball screw drive table	34
3.14	Identification procedure	35
3.15	Physical model of single ball screw system	37
3.16	Physical model of TTDS	37
4.1	Front view	38
4.2	Top view	39
4.3	Side view	39
4.4	Overall design of TTDS	39
4.5	Preliminary result on stress test of large mover	40
4.6	Stress test on aluminium type large mover	41
4.7	Bode plot of TTDS	42
4.8	Comparison of velocity curve for the reference system and simulated system	43
4.9	Error of velocity displacement of the reference system with the transfer functions	43
4.10	Step response of TTDS with reference input of 1 mm and 2 kg of load	44
4.11	Step response of TTDS with reference input of 1 mm and 10 kg of load	45
B1	Step response of TTDS with reference input of 1 mm and 4 kg of load	55
B2	Step response of TTDS with reference input of 1 mm and 6 kg of load	55
B3	Step response of TTDS with reference input of 1 mm and 8 kg of load	56
C1	Physical model of motor	57
C2	Physical model of ball screw	57
C3	Physical model of mover	57
D1	Orthographic of large mover	58
D2	Orthographic of base	58
D3	Orthographic of scale guide way	59

D4	Orthographic of dummy	59
D5	Orthographic of motor bracket	60

**LIST OF APPENDICES**

<b>APPENDIX</b>	<b>TITLE</b>	<b>PAGE</b>
A	Equation Of Motion	54
B	Step Response Of Ttds With Single Axis Ball Screw System	55
C	Physical Model	57
D	Parts Of Ttds	58
E	Tf Algorithm	61



## CHAPTER 1

### INTRODUCTION

#### 1.1 Overview

This chapter presents the motivation, problem statement, objective, and scope of the proposed project.

#### 1.2 Motivation

Malaysia was one of the few countries that swam against the tide during the deindustrialization in late of 1990s. Manufacturing shares in Malaysia's manufactured goods have risen from 25% in early 1980s to 80% in 2012 [1]. This statement showed that the increased in amount of manufacturing sector over these decades. The growth in manufacturing is expected to increase over the year until year 2020 based on Figure 1.1.

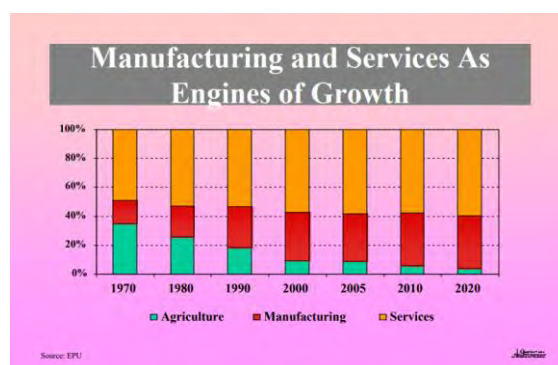

Figure 1.1: Manufacturing and Services as Engines of Growth [2]

With the increases in manufacturing sector, the demands on machines will also increase to maximize the productivity. This will lead to the increase of weight driven in corresponding to productivity.

In machine tool and semiconductor manufacture fields for examples machining centre, a semiconductor photolithography machine, and others [3], the need for high precision and fast response time in numerical control machine is rapidly growing [4]. As the load weight to be driven increases, multiple axis table drive system is in demand.

Twin-axes table drive system (TTDS) is installed with multiple motors which move in same direction simultaneously. The use of multiple motors generates high power for heavy duty tasks with low cost.

### **1.3 Problem Statement**

Research on the TTDS has received a lot of attention. The previously technology is single ball screw system which is unable to sustain the increase of the load weight to be driven. Another innovation of this system is needed to address the demand of the industrial growth.

This innovation has led to the development of different types of synchronous to compensate the synchronisation error of the TTDS. Asynchronous motion of the each axis leads to the damage of the drive system. On the other hand, the existence of the synchronous error of both mechanically coupled twin drives remains the main problem. This error is caused by the characteristics of the drive system. Friction and other disturbances as well, prevent the system to achieve the desired performance. In order to compensate these errors, the system's characteristics need to be well understood. The system's characteristics define by a transfer function can be obtained using the modelling technique. This model of the system's characteristics needs to be verified to ensure the error is within the acceptable range.

Besides, the performance of the TTDS is concerned by all the parties involved. The performance of the system is a crucial for the productivity. The replacement of the new system is required to compare with the old system, single ball screw system in term of capability to drive load.

## 1.4 Objectives

The aims of the Final year Project (FYP) are:

- 1) To design and develop a twin-axes table drive system (TTDS), which is driven by DC servo motors with ball screws.
- 2) To model the dynamic characteristics of the twin-axes table drive system (TTDS) via frequency response method through simulation.
- 3) To validate the transfer function via simulation.
- 4) To compare the performance of single axis ball screw and twin-axes table drive system (TTDS) with varying load via Simscape.

## 1.5 Scope

The extents of the area of TTDS are:

- 1) This system is installed with two units of:
  - a) DC servo motors: 30VDC
  - b) Linear encoder: 5 $\mu$ m.
  - c) Linear guides
- 2) Both axes have a mover that joint together via a longer mover.
- 3) The mover motion is in either forward or backward direction.
- 4) The maximum load weight to be driven by this system is 10Kg.
- 5) The modelling and performance comparison of TTDS is conducted via simulation

## 1.6 Report Outline

Chapter 2 covers the basic principle of twin-axis table drive system which consists of motor and ball screw. Reviews of previous related works and evaluation on control methods are also presented.

Chapter 3 discusses the methodology to accomplish the objectives of the project. Explanations on the selected components and related experiments are

described to ensure the attainment of the objectives. These details include the procedures used.

The results are presented in Chapter 4. Design of the TTDS is illustrated using SolidWorks with the stress test on large mover. The mathematical modelling and performance comparison of TTDS is obtained using Matlab. Chapter 5 provides the summary and suggestion for future works for the proposed project.

## CHAPTER 2

### LITERATURE REVIEW

#### 2.1 Overview

Basic working principal of TTDS and types of motor will be presented in this chapter. In order for the TTDS to perform better, single loop controllers are discussed. Different types of synchronous control methods are reviewed in order to control the motion of both axes. Reviews on previous works related to twin-axes table drive system from different journals or conference papers are presented. Evaluation is done based on the previous works.

#### 2.2 Twin-Axes Table Drive System

The usage of dual-stage system started since late 1980s. Dual-stage system is defined as a combination of coarse and fine stages whereby each stage is driven by a coarse actuator and fine actuator respectively [5]. [6] proposed two drive units arrange to form a single feed axis in modern gantry type configurations. Such drive units has the potential applications in wave makers, machining tools, large sized liquid crystal panel producer machine, and others. Recently, commonly used driven stages in industrials are ball screw driven stage and linear motor driven stage. Both types of stage are synchronised with synchronous control. Types of synchronous controls used are cross-coupling motion control, master-slave motion control and relatively dynamics stiffness motion control [7]. Different single loop controls are introduced before the introduction of synchronous motion control.

### 2.2.1 Ball screw driven stage

In earlier days, hydraulic actuators are used in positioning applications, but require many valuable hours of testing and maintenance [8]. Piezoelectric Actuators (PAs) are used to replace hydraulic actuators in the application of micro positioning. However, this actuator has limited displacement application where the size of PAs increases for long distance application and result in increase of driving voltage. This problem leads to the implementation of ball screw actuator by servo motor. Servo motor is capable of ensuring precise control of angular or linear position.

The common configuration of single ball screw drive used is shown in Figure 2.1, where the mover slides along with one or more linear guides. The linear motion is generated by ball screw with servo motor [9].

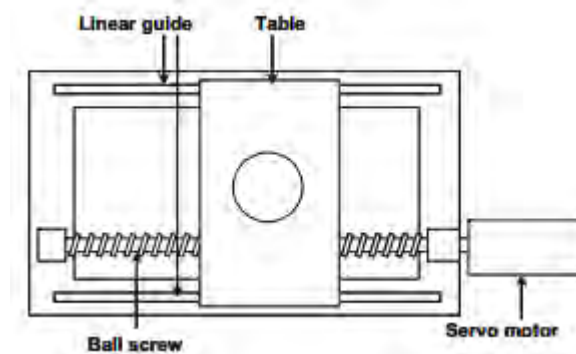

Figure 2.1: Single ball screw drive stage [9]

A servo motor operates in rotary motion, requires a linear motion translator. The ball screw translates rotational motion to linear motion with little friction. Additional mechanism of linear guide is also required to ensure the motion of the mover remains in straight line. A positioning control of both type of drive system is dependent on position detector [10] such as linear encoder.

This configuration is capable in achieving satisfactory accuracy. In recent development, improvements are made in term of work piece scale. Larger ball screw driven stages are recommended to drive greater load weight. This condition has resulted in large spans between linear guides of stages and may reduce the accuracy due to the occurrence of skewed.

[9] proposed the solution to drive the mover of a large single feed axis with two ball screws and motors which provide a joint thrust for driving the large mover as shown in Figure 2.2. [11] also proposed the use of parallel drive mechanism of ball screw to replace the oil pressure drive system with injection moulding machine. The high stiffness, high transmission accuracy and low sensitive to variation in working with cutting force and workpiece mass make ball screw the preferable machine used in industries [12, 13].

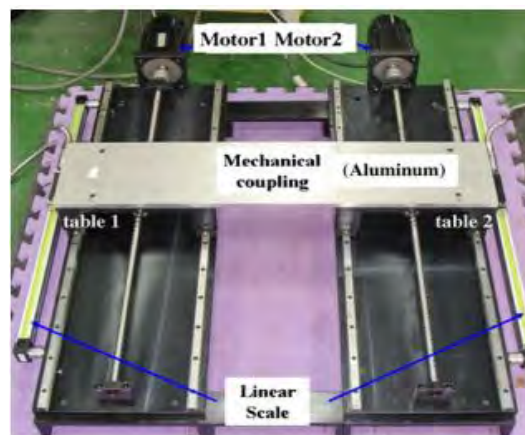

Figure 2.2: Twin ball screw drive system [9]

Drive mechanism of ball screw and servo motor consumes less power than oil pressure drive mechanism. However, such application requires large diameter of ball screw and limits the rotation speed. It is necessary to use multiple motors with smaller diameter of ball screw to achieve desired injection speed as shown in Figure 2.3.

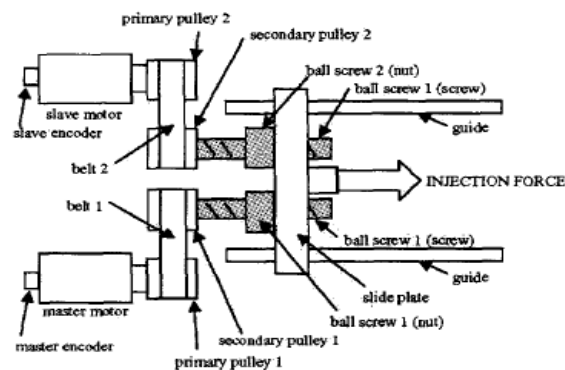

Figure 2.3: Parallel ball screw drive system [11]

From the reviews, servo motor is favourable for ball screw drive system [9], [14]. Servo motor has built-in rotary encoder which can detect rotational angle and angular speed of the motor. This feature allows feedback to controller for better controlling purpose.

### 2.2.2 Linear Motor Drive Stage

Linear motor is latest technology of motor and has been applied to actuate drive stage [7] as shown in Figure 2.4.

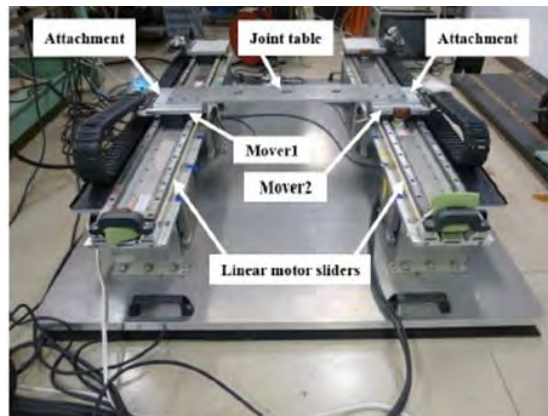

Figure 2.4: Twin linear motor drive system [7]

In general, linear motor and rotary motor has the same working principle. A linear motor is produced when a rotary motor is split and stretch in plane as shown in Figure 2.5.

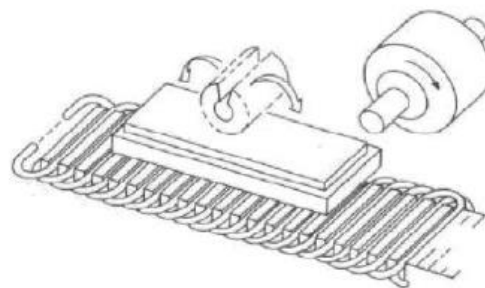

Figure 2.5: Structural similarity of linear motor to rotary motor [15]