

ASTM F138 Steel Metallurgical Characterization and CTOD Analysis Applicable to Orthopedic Implants

Pamela de Matos^{a*}, Charles Leonardo Israel^b, Leandro de Freitas Spinelli^c

^{a,b,c}*Faculty of Engineering and Architecture. Laboratory of Bioengineering, Biomechanics, and Biomaterials
University of Passo Fundo, BR 285 São José, Passo Fundo, CEP: 99052-900 Rio Grande do Sul, Brazil*

^c*Federal University of Health Sciences of Porto Alegre, Rio Grande do Sul, Brazil*

^a*Email: pameladm23@gmail.com*

Abstract

The purpose of this paper is to verify the proceedings of the fracture toughness test CTOD applied to austenitic stainless steel F138, commonly used for orthopedic implants. A metallurgical characterization of sample materials was performed in which chemical composition analysis, micrographs, micro Vickers hardness tests, inclusion analysis, and scanning electron microscopy were also evaluated. In order to illustrate the technique, some rejected samples by the quality control from different suppliers were obtained and tested. This study was based on procedures governed by standards [1,2] which regulate the performance of CTOD toughness tests, with the purpose of evaluating the mechanical resistance and useful life of prosthetics. The standard [3] governing the basic properties of materials accepted for prosthetic production has also been studied.

Keywords: prosthesis; CTOD; K_{IC} ; orthopedic implants; ASTM F138.

1. Introduction

Orthopedic stainless steel implants have been widely used since the nineteenth century with significant success rates and improved patient quality of life and movement, whether temporary or permanent [4]. In Brazil, no medical product may be manufactured, exposed for sale, or delivered for consumption without first being registered with the Ministry of Health [5]. Regulatory agencies perform a series of analyzes directly and indirectly on the product and also on the manufacturer, in order to guarantee the quality of the process and the product and to control factors that can generate health risk. However, pre-market assessment may not be sufficient, as once the product enters the market, some unexpected problems may occur.

* Corresponding author

According to [3,6], there is a consensus that a homogeneous metallurgical structure is superior in terms of resistance to mechanical fatigue. In order to meet this requirement, it is generally determined that these materials have austenitic structure, with fine grain in uniform size and reduced presence of inclusions. Health Services should be aware of such details when purchasing surgical implants, carefully checking the raw material and its specifications, always trying to choose the most appropriate material. Implants with permanent orthopedic application need to be quality assured to last long periods without losing functionality, avoiding problems that may affect the patient's life. Seeking to provide information and create an evaluation standard for ASTM F138 steel prosthesis, this work proposes a metallurgical characterization to ascertain the basic properties that guarantee the minimum reliability of the material, besides studying the application of CTOD and KIC fracture toughness analysis, seeking to make the results about the strength of the prostheses more palpable, and the material's life span so that during the design phase, the improvement of the product is sought in order to avoid surprise failures in the pre- and post-marketing phase (avoiding disorders for the manufacturer), and also that patients have a higher level of satisfaction with prosthetics and their durability.

1.1. Objectives

The present paper aims to illustrate and to verify the proceedings of the fracture toughness tests of the type CTOD in ASTM F138 steel, providing relevant information to the manufacturers about the mechanical strength of orthopedic implants, advising on the inspection to be made on the raw material. And also specifically:

- Develop an evaluation methodology for orthopedic implants tenacity analysis for laboratory use;
- Make metallurgical characterization of samples through chemical composition analysis, micrographic analysis, grain count, micro hardness analysis and roughness analysis;
- Identify the fracture micro mechanisms present in the CTOD test and quantify the crack opening;

2. Materials and methods

For the present study, three samples rejected by the quality control from different suppliers were donated to the university, with base material described as ASTM F138; such samples were obtained only for research purposes, not for implant. Subsequently they were machined in accordance with [1,2] standards, adopting a square section for body type SE(B), and extracted two samples of each sample, totaling six test specimens. The final dimensions follow figure 1.

The initial base of the specimen was extracted in the cooling disc-cutting machine, totaling a length of 63mm; the shape was given with the milling process. After, the specimen was taken back to the cutting machine to be divided into 2 specimens, to meet the roughness requirements of the reference standard, the specimens went through the grinding process, ensuring the surface roughness Ra of 0.8 μ m. The notch of the specimen was obtained through the process of wire EDM. The final specimens can be seen in figure 2.

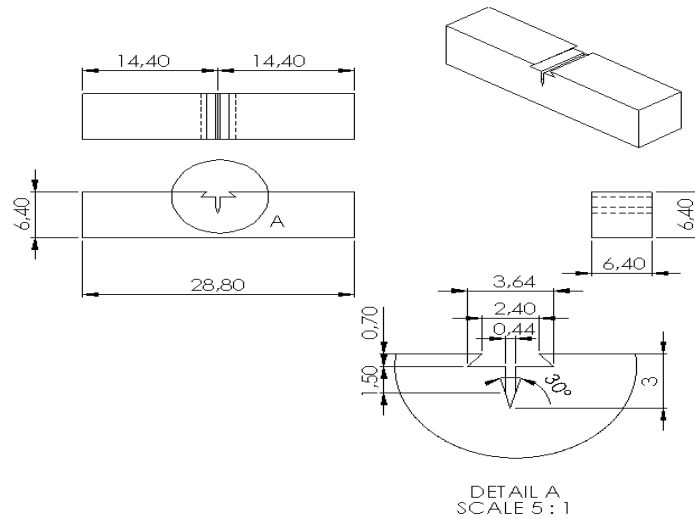

Figure 1: scheme of final sample dimensions (scale in mm).



Figure 2: SE (B) test-ready specimens.

2.1. Samples Properties

For metallurgical characterization of the samples, micrographs of their microstructure were performed, followed by inclusion analysis according to [7], grain count according to [8], Vickers hardness analysis [9], roughness analysis and chemical composition analysis by optical spectroscopy in order to observe if the material follows the chemical composition governed by [3]. Three samples were extracted at the proximal end of the stem, and one at the distal end. Three of them, extracted crosswise, were intended for micrograph and grain size analysis, and one of them was taken in longitudinal position and was intended for inclusion analysis. All three samples had the same number of specimens removed. The micrograph was performed based on the [10] standard, and the chemical etching was performed with regal water (1:3 nitric acid and chloridric acid solution). Samples for inclusion analysis went through the same process except the chemical etching step. *Samples that underwent micrographs for morphological analysis were subjected to grain counting using the intercept method, in which the software, available under the microscope, traces the drawing of three concentric circles crossed by two lines forming an "X", a vertical line on the left side and a horizontal line at the bottom of the image. Grain contours*

were manually marked at each point where there was a crossing with one of the lines of the plotted figure. After marking all points, the software generated a report for each sample based on the standard [8]. The hardness of the samples was made directly on the SE (B) specimens, using a Shimadzu Vickers micro-durometer, applying the 2000g load according to [9] and measuring at three different points of each sample. The standard only provides for the Brinell hardness scale, but in order to preserve the samples and not generate stress concentrators, the Vickers micro hardness was chosen. The roughness was made using a Surfetest model SJ-410 roughness meter, which reads the average surface roughness (R_a) and the arithmetic mean roughness of 5 values of the partial roughness (R_z), through a diamond-tipped probe. Three roughness measurements were performed in each of the samples following the reference standard [11].

2.2. CTOD Performing Tests

The available CTOD setup was only compatible with medium sized specimens, however the obtainable specimen is smaller than the original machine configuration. To perform the test, the device had to be altered to meet the standard specifications and then the small specimen was tested. The solution to this problem was to manufacture at the university itself an adaptation for Shimadzu Servopulser equipment that met the test conditions; the adaptation can be seen in figure 3 below.

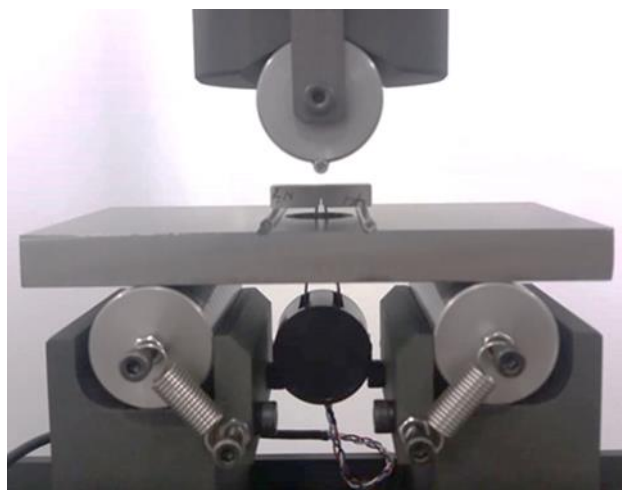

Figure 3: Test adaptation.

The tests were performed following the reference standard [1,2] aiming to measure the resistance of the material to the crack propagation. The procedure was performed at ambient temperature and pressure. The execution of the pre-crack and GLUON4830 Test Execution software operation was performed according to the standard operating procedure created for it. Cyclic loads were applied to the specimen with frequency of 15Hz, ΔK of $15\text{MPa}\sqrt{\text{m}}$ and load ratio $R = 0.1$. The pre-crack opening was monitored by a clip-gage and the test was paused at the time the crack reached the a/W ratio of 0.55. Then, the CTOD assay was performed following the operating procedure developed for it. To calculate the CTOD values, the material properties listed in [3] baseline were used in cold working condition: $\sigma_{LE} = 690\text{MPa}$ and $\sigma_T = 860\text{MPa}$. At the conclusion of the test, the specimens fractured with a few cycles of fatigue and were sent to the SEM for crack size measurement. The

crack measurement was made in the SEM according to [1], and the nine intervals were equally divided, as shown in Figure 4. The spacing in the beginning of the measurement was considered to be 0.15mm. Then the collected data was entered and processed in the GLUON4830 Data Processing software.

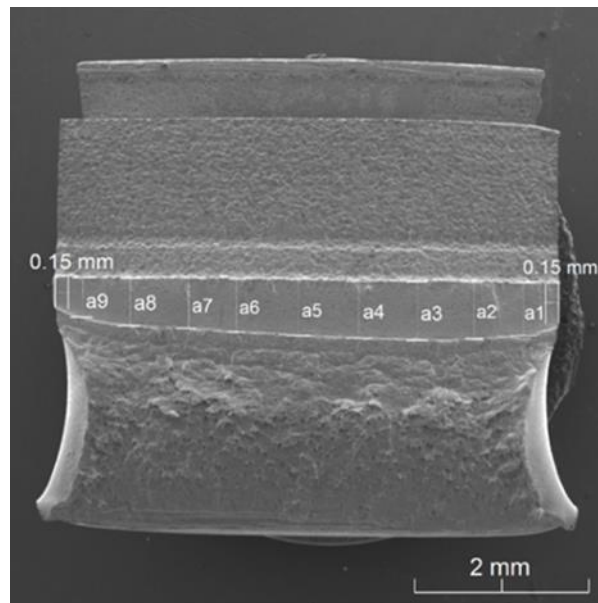

Figure 4: Detailing for crack measurement (60x magnification).

3. Results and Discussion

3.1. Characterization of Samples

Firstly, the analyzed chemical composition of the samples was obtained by optical spectroscopy analysis. A comparison with the standard [3] is shown in table 1, which considered the average of three burns at different points in each sample:

Table 1: Chemical Composition.

Element	Standard	Sample 1	Sample 2	Sample 3
C%	0.030	0.045	0.043	0.145
Si%	0.750	0.253	0.323	0.951
Mn%	2.000	1.680	2.010	3.310
P%	0.025	0.029	0.024	0.075
S%	0.010	0.009	0.007	0.047
Cr%	17 to 19	18.50	18.30	23.60
Mo%	2.25 à 3	2.910	2.750	2.170
Ni%	13 à 15	14.80	15.20	15.00
Cu%	0.500	0.073	0.124	0.525
Fe%	Balance	61.50	61.00	53.40

The chemical composition of samples 1 and 2 were extremely similar to [3]. Sample 3 presented discrepancies in values of the alloy constituents, especially the Chromium content, justifying to be rejected by the quality

control. The samples were analyzed under an Olympus BX51M microscope, and the grain morphology can be observed in table 2:

Table 2: Microstructure: (B) observed in sample 1, (E) observed in sample 2, and (G and H) observed in sample 3.

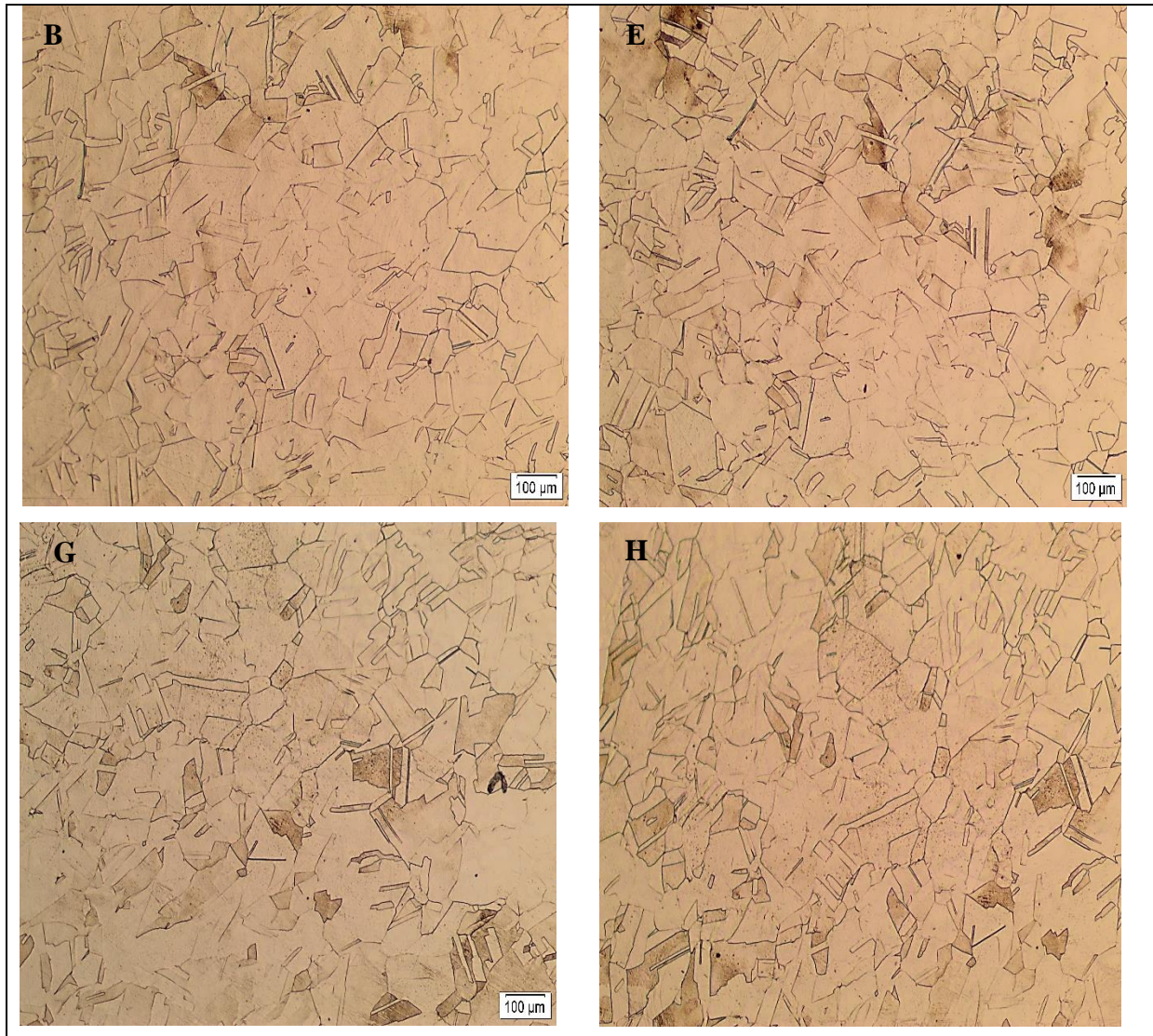

The micrograph observed in the collected samples resembles those found in reference bibliographies and presents the same morphology, making it possible to easily identify it as stainless steel with austenitic structure, with presence of maclas and equiaxial grains, which is compatible with the standards [3]. After, grain size measurements were performed, from these evaluations the software automatically generates reports with the average size calculations and their standard deviations (table 3).

Table 3: Grain Size.

Sample		Grain Size ASTM	Average	Grain Size (μm)	Average
Sample 1	A	7.03		27.98	
	B	6.38	6.82 \pm 0.30	35.03	30.29 \pm 3.34
	C	7.04		27.88	
Sample 2	D	6.74		30.93	
	E	6.20	6.71 \pm 0.40	37.35	31.49 \pm 4.49
	F	7.20		26.39	
Sample 3	G	6.63		32.19	
	H	6.56	6.48 \pm 0.16	32.99	33.61 \pm 1.48
	I	6.25		35.66	

The samples taken in the longitudinal direction for inclusion analysis were only polished and were analyzed under the same microscope. The inclusion morphology observed in the samples can be seen in Table 4.

Table 4: Inclusions: (A1) observed in sample 1, (B2) observed in sample 2, and (C1 and C2) observed in sample 3.

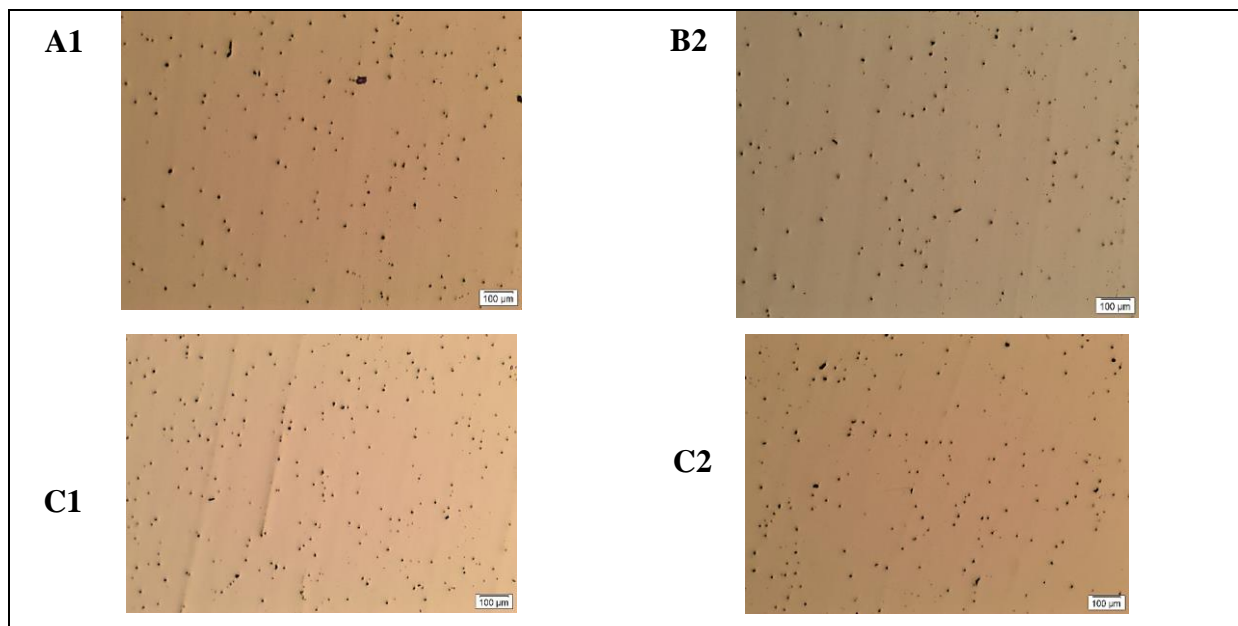

Table 5: Inclusion rate observed in the samples.

Sample		Inclusion Rate	Average
Sample 1	A1	1.06%	1.04% \pm 0.02%
	A2	1.01%	
Sample 2	B1	1.10%	1.06% \pm 0.03%
	B2	1.02%	
Sample 3	C1	1.38%	1.32% \pm 0.05%
	C2	1.26%	

The evaluated samples presented inclusions with globular format, being classified by the standard [7] as

belonging to “D” series of coarse series globular oxides. The percentage value of the inclusions found in 100 times magnification can be observed in Table 5.

The inclusion limit mentioned in [3] is 1.0. Based on this, the analyzed samples are out of the required standard, especially in sample number 3, where the values are more expressive, justifying the quality control in rejecting the samples. Micro-Vickers hardnesses scale, means, calculated standard deviations and their respective values were converted to Brinell hardness and can be seen in table 6.

Table 6: Samples Hardness.

Sample	Hardness(mHV)	Average	Hardness(HB)
Sample 1	220	237 ± 15	209
	236		224
	256		243
Sample 2	232	228 ± 11	220
	213		202
	240		228
Sample 3	235	236 ± 15	223
	254		241
	218		207

The micro-hardness measured in Vickers scale presents little variation in the hardness of samples 3 and 1, and a lower average hardness in the sample number 2. The roughness of the samples was measured following the standard [11], and can be seen in table 7.

Table 7: Roughness of the samples.

Samples	Ra (µm)	Average	Rz (µm)	Average
Sample 1	0.035	0.043 ± 0.011	0.334	0.227 ± 0.126
	0.036		0.297	
	0.059		0.049	
Sample 2	0.024	0.032 ± 0.006	0.391	0.269 ± 0.095
	0.041		0.158	
	0.031		0.258	
Sample 3	0.022	0.029 ± 0.008	0.158	0.289 ± 0.178
	0.042		0.541	
	0.024		0.168	

A noticeable variation in roughness on the surface of the samples can be observed, as well as in the comparison between samples.

3.2. Results of CTOD Assay

The data related to the applied force, the values of K (stress intensity factor in the crack tip), which is a function of the force applied to the crack length, V_p , CTOD and even the fracture mode, we obtained during the CTOD

tests, through processing in the GLUON4830 Data Processing software. These values can be seen in table 8.

Table 8: CTOD of the samples.

Samples	Force (kN)	Pop-in	K(Mpa√m)	Vp (mm)	CTOD (mm)	Fracture mode
Sample 1	1.333	yes	35.588	0.101	0.0272	5
Sample 2	3.067	no	80.635	1.874	0.4561	6
Sample 3	2.233	no	59.690	2.272	0.5312	6

The force versus displacement curves presented by each sample can be seen in table 9.

Table 9: Force X Displacement curves CTOD.

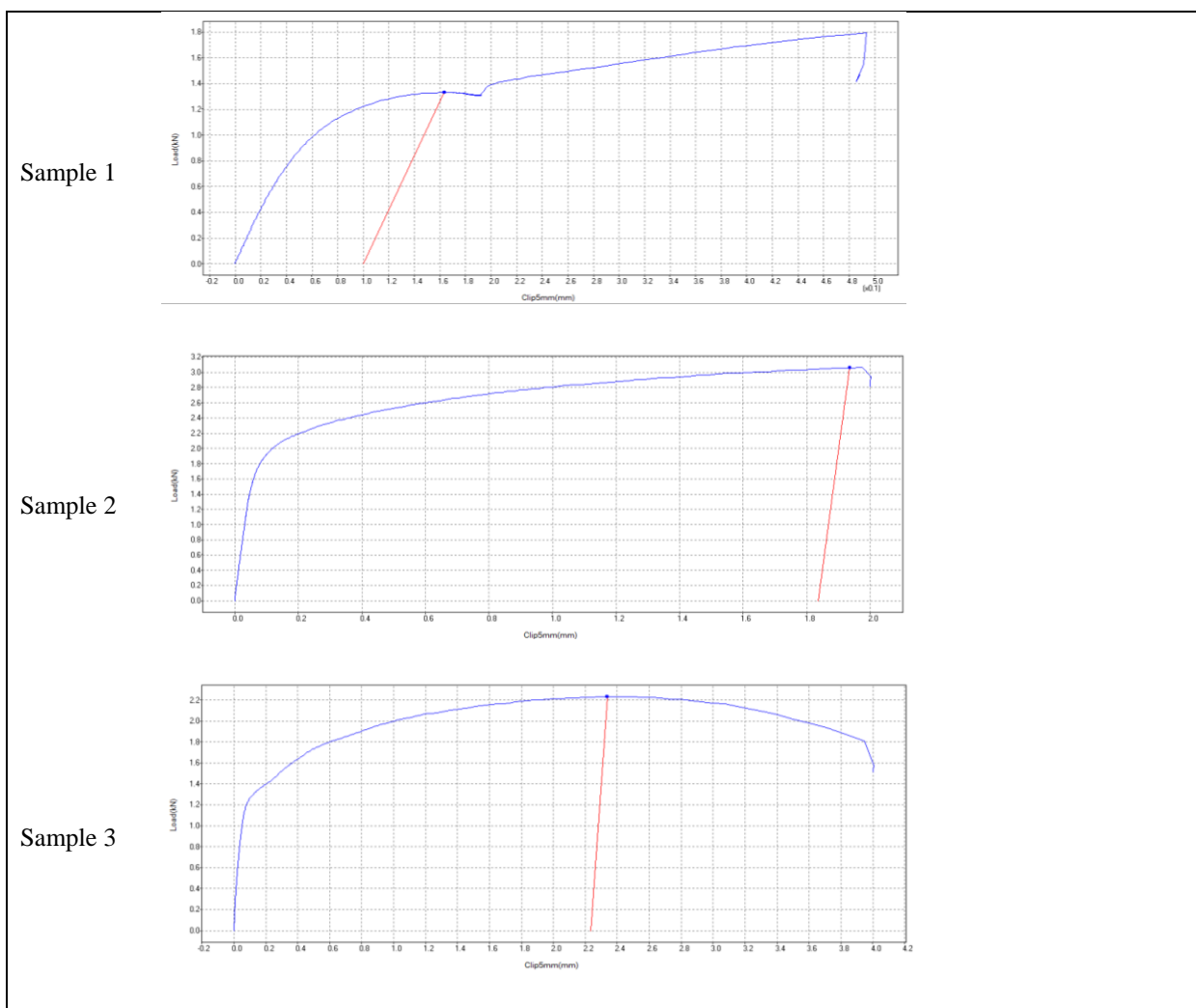

After completing the CTOD assays, all samples were sent for scanning electron microscopy (SEM) analysis to identify the fracture micro mechanism. The images made in the SEM can be seen in table 10.

Table 10: Structure observed in SEM, magnification 60x, 150x, 100x respectively.

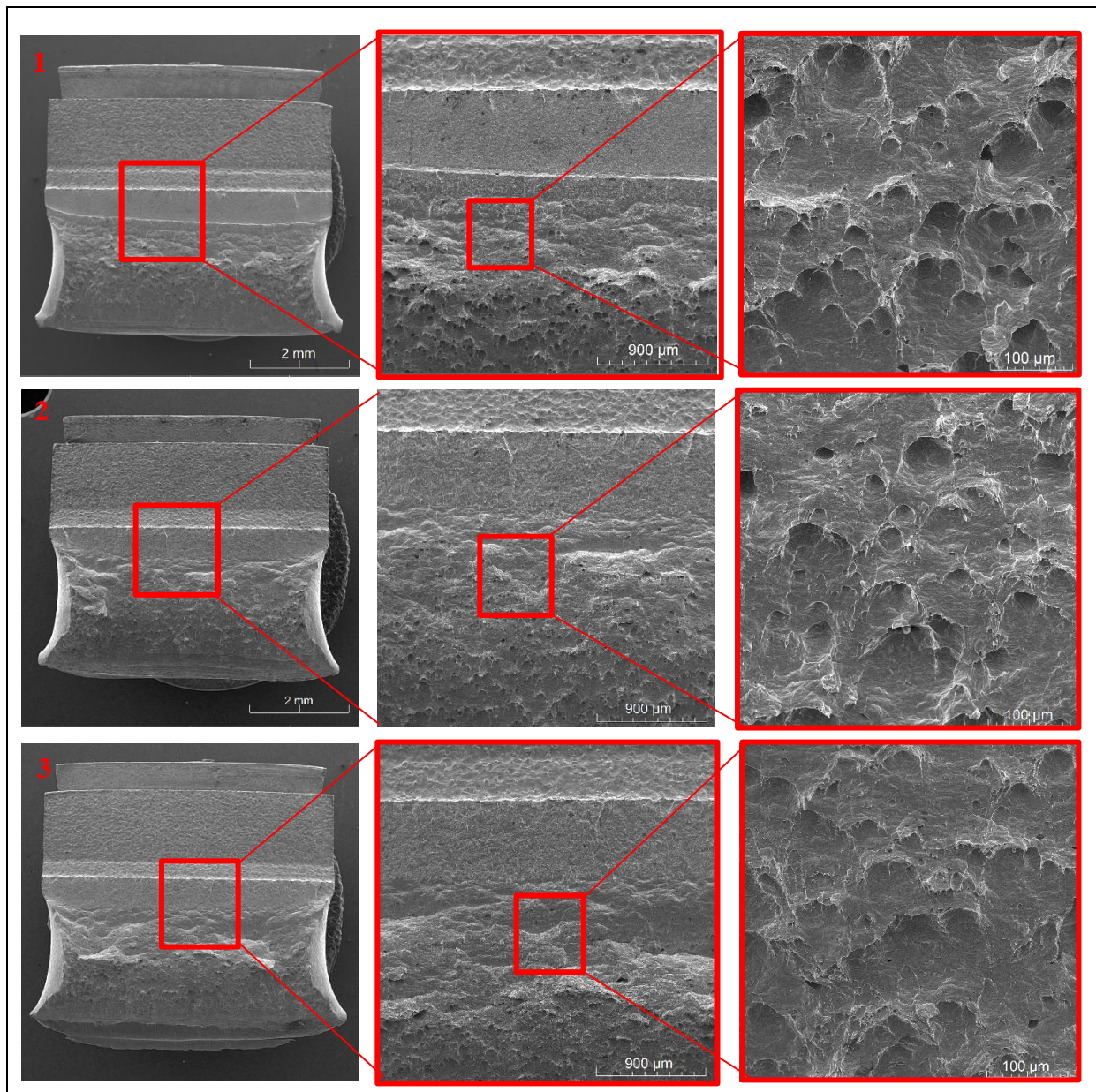

In all samples it is possible to observe the micro mechanism of alveolar fracture (dimples), characterizing a ductile fracture.

3.3. Discussion of Results

The paper illustrated and verified some proceedings of the fracture toughness tests of the type CTOD in ASTM F138 steel, providing relevant information to the manufacturers about the mechanical strength of orthopedic implants, advising on the inspection to be made on the raw material. The research also developed an evaluation methodology for orthopedic implants tenacity analysis for laboratory use; performed a metallurgical

characterization of ASTM F138 samples through chemical composition analysis, micrographic analysis, grain count, micro hardness analysis and roughness analysis; identified the fracture micro mechanisms present in the CTOD test and quantify the crack opening;

For the F138 stainless steel evaluated in this work, based on the results seen above, the following observations can be considered:

- Chemical composition values for ASTM F138 samples number 1 and 2 are within the limits set by the reference standard. Sample number 3 presented problems regarding the chemical composition, presenting variations of about 25% in each element. This variation in chemical composition can be attributed to a batch defect or manufacturing process failure, justifying the batch to be rejected by the quality control;
- The microstructure morphology observed in the samples is compatible with the bibliography, presenting austenitic structure, also presenting maclas and equiaxial grains;
- The grain size conforms to the reference standard as it attests that the grain must be ASTM size 5 or finer and the observed grain size was between ASTM size 6 and 7;
- The inclusion rate observed in the samples is higher than the rate allowed by the standard, especially in sample number 3, justifying to be rejected by the quality control. The latter may have the highest inclusion rate because its chemical composition is not in compliance;
- The maximum hardness limit described by the reference standard is 250 Brinell, but this limit only predicts the condition of annealed material, and there is no information on which heat treatments the samples were subjected to. There is no hardness range established for other material conditions or a minimum value to follow;
- Average (Ra) and arithmetic (Rz) roughness are outside the standards required by the reference standard, presenting a roughness deviation of about 28% above the allowed, justifying to be rejected by the quality control;
- Due to the limited number of samples, the tensile test could not be performed to ascertain the actual yield strength and tensile strength of the material. This factor made it difficult to open the pre-crack in the first sample;
- CTOD test results attest to the ductile fracture mechanism for all three samples. SEM analysis confirms these results since alveolar fracture micro-mechanism (dimples) is present in all samples, which is an indicator of ductile fractures. This result is compatible with the material morphology;
- Forces versus displacement curves generated from the collected data are also characteristic of ductile materials. It is noted that the material has a large zone of plastic deformation and considerable toughness;
- No regulations were found by regulatory entities regarding the manufacture of orthopedic implants or data specifying CTOD value considered satisfactory for this particular case.

The authors recognize that the number of samples in this paper is small, but since the paper proposes a methodology and the objective is not limited to only analyzing the prostheses, it can be applied to the most

diverse fields of medicine, dentistry and veterinary, as long as they involve metallic materials.

4. Conclusions

The objective of developing an evaluation methodology for orthopedic implants toughness analysis for laboratory use has been achieved. The work itself can act as a basis for clarification of the procedure and the test, taking into account the [1,2]; Metallurgical characterization of the material, the fracture micro mechanisms present in the CTOD assay and the quantifying of crack opening were also performed in the present work.

5. Recommendations

The proposed methodology can be applied to other materials used in the medical, dental, veterinary or even other areas. Due to the fact that this is a new methodology, it is necessary to apply it with caution, following the test criteria and standards provided for different types of materials.

References

- [1] British Standard BS 7448-2, "Fracture mechanics toughness tests. Method for determination of K_{Ic} , critical CTOD and critical J values of metallic materials," Br. Stand. Inst., 1991.
- [2] ASTM Standard E1820, "Standard Test Method for Measurement of Fracture Toughness," ASTM B. Stand., no. January, pp. 1–54, 2013.
- [3] ASTM F138, "Standard Specification for Wrought 18Chromium-14Nickel-2.5Molybdenum Stainless Steel Bar and Wire for Surgical Implants," ASTM Int., pp. 1–5, 2013.
- [4] V. A. Guimarães, "Influência da microestrutura sobre as propriedades mecânicas e resistência a corrosão de um aço inoxidável ISO-5832-9 utilizado na fabricação de implantes ortopédicos." Universidade Estadual de Campinas, 2002.
- [5] C. R. Azevedo and E. Hippert Jr., "Retrieval and failure analysis of surgical implants in Brazil: the need for proper regulation | Análise de falhas de implantes cirúrgicos no Brasil: a necessidade de uma regulamentação adequada.," Cad. Saude Publica, vol. 18, no. 5, pp. 1347–1358, 2002.
- [6] I. Abud, C. Barbosa, I. Caminha, and J. Nascimento, "OCORRÊNCIA DE FALHAS PREMATURAS EM IMPLANTES ORTOPÉDICOS NO BRASIL," in Congresso Latino Americano de Órgãos Artificiais e Biomateriais, 2012.
- [7] A. C. S. Cechin and S. Paciornik, "Classificação automática de inclusões em aço," 65th ABM Int. Congr. 18th IFHTSE Congr. 1st TMS/ABM Int. Mater. Congr. 2010, vol. 3, pp. 2301–2312, 2010.
- [8] ASTM International, "ASTM International, E112: Standard Test Methods for Determining Average Grain Size," West Conshocken, vol. 96, no. 2004, pp. 1–26, 1996.

- [9] ASTM International, “ASTM E92 - Standard Test Methods for Vickers Hardness of Metallic Materials,” Standard Test Methods for Vickers Hardness of Metallic Materials, vol. 3, no. Reapproved. p. 9, 2017.
- [10] ASTM Standard E3-95, “Standard Practice for Preparation of Metallographic Specimens,” ASTM Int., vol. 04, no. March, pp. 1–9, 1995.
- [11] INTERNATIONAL ORGANIZATION OF STANDARDIZATION, “ISO 4287: Surface texture: Profile method -Terms, definitions and surface texture parameters.” Geneva, 1997.