



## The Response of Residents of the Building and Non-structural Components, in Contrast to Explosions at Ground Level from the Standpoint of Passive Defense

MohammadReza Mozaffarpour Taromi <sup>a</sup>, Hossein Khosravi <sup>b\*</sup>

<sup>a</sup> Department of Civil Engineering, Science and Research Branch, Islamic Azad University, Tehran, Iran.

<sup>b</sup> Department of Civil Engineering, Hakim Sabzevari University, Sabzevar, Iran.

Received 15 April 2018; Accepted 19 January 2019

### Abstract

The research by non-military research associations and assemblies on explosion have increased due to the growth in the death and damage rates resulting from explosion, particularly blasts induced by terroristic invasions which mostly occur on the ground. Most studies are conducted with a major focus on strengthening the structures against explosions. Further, scholars have focused on resistance and ductility criteria required for the design and control over structural elements. Now, the question is whether the health of a structure can represent its inhabitants' health. Few studies have been done on the convenience of inhabitants and response of non-structural elements, which are limited to impact of vibrations on high-rise structures caused by the loads imposed by wind and earthquake. The important factors relevant to the health and convenience of building inhabitants are as follows: speed, acceleration, and variations in the acceleration of floors.

In this paper, the aforementioned parameters are measured, according to which the convenience and health of inhabitants were assessed. For this purpose, two 4-story and 8-story buildings were selected on which four selective explosions were applied. The results were then presented in two forms of maximum values and dynamic response by performing dynamic modal linear time history analysis. The building's response under typical forces such as dead and live and earthquake forces was remarkably desirable and the behavior remained linear, but the building's acceleration may cause serious injuries in terms of human comfort criteria. The obtained results indicated that the healthy state of the structure does not represent the health of the building inhabitants. Further, although the building was safe against the elective blasts, the lateral accelerations were capable of imposing significant damages to the building residents. This can be considered as a criterion for control and future designs from a passive defense point of view, as the explosions induced by terroristic attacks is increasing.

*Keywords:* Blast Loading; Passive Defense; Dynamic Modal Linear Time History Analysis; Design and Structure Control Criteria.

### 1. Introduction

Parallel with the developments of military sciences and easy access to the science of construction explosive materials, there has been a dramatic rise in the rates of terroristic explosions over recent years, causing casualties and financial losses in urban communities. So, many studies have been performed to understand the effects of explosion on structures. These scholarly activities include determining the load exerted on the buildings close to the site of explosion, the behavior of materials toward the rapid loading rate, and the general and partial behavior of structures against dynamic blast load. In most studies, the impact of explosion on inhabitants of the building has not been considered.

\* Corresponding author: [h.khosravi@hsu.ac.ir](mailto:h.khosravi@hsu.ac.ir)

<http://dx.doi.org/10.28991/cej-2019-03091262>

➤ This is an open access article under the CC-BY license (<https://creativecommons.org/licenses/by/4.0/>).

© Authors retain all copyrights.

Few studies have been conducted regarding the impact of explosion waves on the hearing threshold and the direct impact of blast on humans. But, the majority of studies have not dealt with the impact of dynamic response of structure on inhabitants' and non-structural elements. In designing structures according to resistance and ductility criteria, it is assumed that by maintaining the health of the structure, its inhabitants will remain healthy as well. On the other hand, the studies related to the vibrations of high-rise structure induced by wind force have demonstrated that although the structure survives against the vibrations, the inhabitants will suffer from diseases caused by vibrations. Further, the non-structural elements will collapse or the balance of inhabitants will be disrupted, due the vibrations imposed by intensive earthquakes, all of which can lead to casualties and financial losses. These results suggest that it is essential to study the health and convenience criteria for inhabitants. The present article seeks to investigate the impact of load induced by explosion on the response of non-structural elements and health of building inhabitants.

In this research, buildings are being studied, whose design is based on engineering standards and common rules and regulations, and the behavior of these structures even against the earthquake is linear and been approved. Further, by modeling the explosion charge and studying the structure response to it and the acceleration caused by the explosion and comparing the accelerations with the tolerable range of humans, we will see that, despite of the health of the structure, serious damage to the residents of the building will occur. A criterion that has not been considered in the design of human residential buildings so far.

## 2. Literature Review

The main focus of previous studies has centered on the behavior range of the structure, exposed to the impact of explosion, such as the study performed by Mullen and Tadepalli (2006). They examined the parameters governing the behavior of concrete frames subjected to the impact of blast. They designed a frame for live, dead, wind, and earthquake loads, and then used TM5-1300 command for columns of frame in order to generate compression-momentum curves. They further utilized fiber hinge model, where the generated curves were used for detecting the failure degree resulting from explosion. For identifying the extent of impact of effective parameters on re-distribution of the forces induced by explosion, finite element non-linear static models were used [1].

Ramsay et al. (2007) studied the blast loading and its impacts on a concrete structure. They inspected the blast phenomena and its possible effects on the structure [2]. Bao and Li (2010) focused on over-strength of a reinforced concrete column which was damaged. They accomplished numerical simulation of the axial over-strength related to the reinforced concrete column. Then, they modeled 12 specimens of column and studied parameters including contraction ratio, axial load ratio, longitudinal bar ratio, and performance level of the column. They used these values for developing a formula which could be used for calculating the axial force based on the deformations of the bay's middle part [3].

Regarding the inhabitants' comfort criteria, a series of studies have been conducted which have measured tolerance with response acceleration. For instance, Clevenson et al. (1978) experimentally studied the impact of vibration duration on inconvenience for humans, and the findings were used for travelers of the air vehicles. They used four variable acceleration models with a domain of 0.1 g and studied nine 1-hour temporal samples. The vibrations were selected spectrally with a bandwidth of 10 Hz centered at 5 Hz. The obtained results revealed that discomfort could occur at 0.027 g acceleration at all time periods. All applied accelerations were in vertical form. However, for acceleration balances beyond the uncomfortable limit, systemic reduction would occur for inconvenience of the travelers associated with increase in time duration of applying vibration. Also, Clevenson et al. (1978) considered the reduction rate of inconvenience to be independent of acceleration degree. Indeed, theoretical inconvenience due to the vertical vibrations was clear, while the time increase was reduced [4].

Naeim (1991) studied a design procedure which can be used for preventing floor vibration. He focused on the impact of aerobic or other similar activities done by residents of the building, which led to development of undesirable or even destructive vibrations. Accordingly, he proposed a new design procedure and presented the influential parameters on feeling similar vibrations including human body state, properties of vibration source, duration of exposure to the vibration, properties of the floor system, degree of expectation (in-service expectation), and type of activity leading to vibration. According to Figure 1 and in accordance with ISO, the maximum frequency of human's perception in Z and Y or X directions ranges from 4 to 8 Hz and from 0 to 2 Hz, respectively [5].

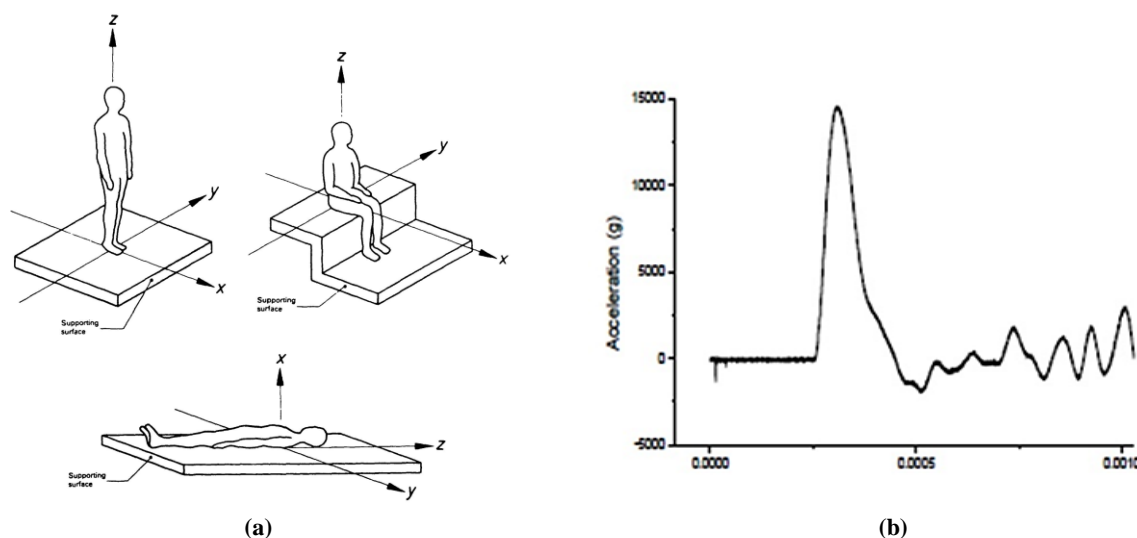

**Figure 1. a) Various positioning of humans; b) Response acceleration of steel plate recorded by accelerogram under blast load [6]**

Boyd (2000) focused on a similar topic and investigated the acceleration of a plate under explosion. The main purpose of his study was to calculate the maximum acceleration resulting from explosion in order to determine the health or damage to the ship crew in response to the impact of explosion. He sought to propose an appropriate finite element model for further studies. Figure 2 displays a sample of his findings. Due to the impact of explosion, two ranges of impact may have a significant impact on individuals. Note that the second zone is similar to a car accident. On the other hand, few studies have examined the first zone and the damages incurred to the ship crew. The magnitude of energy for the first zone transferring directly from strike wave to human body was higher than the tolerance threshold of human, which incurred significant damages to the human body [6].

Crawford (2003) showed that the body of human kept on a chair and acceleration of 40g is applied on him/her for short duration (up to 50 ms), can resist, while significant damages will be imposed on the body. During emergency aircraft evacuation (ejection seat), an acceleration ranging from 18g to 25 g is applied on the pilot for 500 ms [7].

Voshell (2004) studied human body under high accelerations. He investigated the impact of high acceleration during car racing and the study acceleration was less than 5g. Also, he has focused on the impact of this amount of acceleration on drivers of these automobiles [8].

Mendis et al. (2007) have investigated the wind loading imposed on high-rise buildings. They presented a series of criteria based on life quality of the residents subjected to wind, acceleration and fluctuations frequency (Table 1).

In the field of comfortability of the building residents, there is no specific standard, while a bulky amount of research has been conducted in the field of Psychological aspect and the impact of environmental factors on human for high-rise structures subjected to low frequencies [9].

In 2012, Noss, in his master's thesis, investigated the interaction between humans and structures in vitro and in analysis. During this research, the specific effects of human on the structure have been investigated. In structures with a lot of inhabitants, people can influence the damping of the structure and this effect has been studied in this research. Looking at the data on the sudden stop in passenger cars and trains, it has been shown that individuals can tolerate horizontal acceleration less than 0.44g without losing balance. The duration of these accelerations is several seconds, so the acceleration in consideration Taken for the phenomenon of explosion in relation to the loss of balance of people because of the short duration of its continuity, probably should be more. Horizontal 0.5g horizontal gradient in each case has a safety margin for the individual (regardless of the individual's position; standing, sitting, curved) against a land jet in atomic explosions [15-18].

In 2018, Gao et al., Studied on Human-structure Interaction in building with different amount of occupants and the response of the building on human inside and the vibration induced by the crowd on the building [19].

**Table 1. Impact of acceleration on the occupants of the building**

Level	Acceleration	Impact
1	<0.05	Human can't perceive motion
2	0.05-0.1	a. Sensitive People can perceive the motion; b. Hanging objects may move slightly.
3	0.1-0.25	a. Majority of People can perceive the motion; b. Level of motion may affect desk work; d. Long-term exposure may produce motion sickness.
4	0.25-0.4	a. Desk work becomes difficult or almost impossible; b. Ambulation still possible.
5	0.4-0.5	a. People intensively perceive the motion; b. Difficult to walk naturally; d. Standing people may lose balance.
6	0.5-0.6	Most people cannot tolerate motion and are unable to walk naturally.
7	0.6-0.7	People cannot move or tolerate motion.
8	>0.85	Objects begin to fall and people may be injured.

In 2018, Bulushev and Bunov have studied the dynamic forces in football stadium structures induced by movements of audiences and the human comfort level that should be taken in consideration in the course of design. Therefore, it is necessary to develop appropriate recommendations [20].

Scheu in 2018 has mentioned that while working on floating offshore wind turbines is a complex operation, an important factor is the influence that the structural motion has on humans located on the asset in a harsh environment during maintenance activities and its implications towards personal safety, human comfort and the ability to work [21].

In 2018, Khaksar has checked out the human comfort level and health criteria against the vibration and acceleration and deceleration of the helicopters during the flight [22].

In 2017 Gräbe in his thesis confirms that to improve ride comfort a reduction in the acceleration experienced by occupants is required. It is therefore important to know how large the reduction in vibration should be for occupants to perceive an improvement in comfort [23].

### 3. Research Modelling

Undoubtedly, for determining the impact of explosion on building residents, it is possible to employ direct field experiment. So, the best method is to benefit from previous studies related to the human response to the exerted acceleration and its comparison with acceleration imposed due to explosion. The response and tolerance threshold by human against the time acceleration and vibration have already been discussed by previous studies.

In this section, first we will present building specimens as the study samples. Then, selected explosions will be applied on them to study the impact of explosion load on residents. The study buildings were made of reinforced concrete, and there were 4-storey and 8-storey structures in two height types. The mid-rise moment frame was used as the structural system. Further, it was assumed that the mass for all stories is equal to zero. The buildings were symmetrical with a square-shaped plan. The frames possessed 3 bays, where the length of bay and the height of stories were equal to 5 m and 3 m, respectively. The mass of all stories was equal to 600 kg/m<sup>2</sup> (DL=600 kg/m<sup>2</sup> and LL=200 kg/m<sup>2</sup>). The properties of the concrete were as follows:  $E = 2.5 \times 10^5$  kg/cm<sup>2</sup>,  $M = 2.5 \times 10^{-6}$  kg/cm<sup>3</sup>, and  $f'_c = 380$  kg/cm<sup>2</sup>. The dimensions of the section for each height type are presented in Table 2. Based on the sections presented in Table 2, the concrete buildings were modeled by SAP2000 Software, with the live and dead loads applied on the beams uniformly.

**Table 2. Applied sections and Parameters of considered explosions**

	Story Count	Positioning	Column Section (cm)	Beam Section (cm)
<b>Applied Sections</b>	4	First and second story	50×50	50×35
		Third and fourth story	45×45	45×35
	8	First and second story	60×60	60×35
		Third and fourth story	55×55	55×35
		Fifth and sixth story	50×50	50×35
		Seventh and eighth story	45×45	45×35
	Weigh of explosive materials (kg)	Distance (m)	Scaled distance	
<b>Parameters of explosions</b>	2000	50	3.97	
	6750	75	3.97	
	600	50	5.95	
	2000	75	5.95	

Due to the fact that the selected structures in response to loadings remain in the linear behavior range and their lateral displacements are within the permissible range, it is not necessary to investigate the non-elastic mode of structure. Therefore, the sap 2000 software to model the explosive load and evaluating the structure response is used.

Then, the load of the selected explosions was determined in accordance with UFC3-340-02 [11], which was applied on the study building.

After that, the results were obtained in terms of lateral drift, lateral velocity, and lateral acceleration values for stories using dynamic modal linear time history analysis. Table 3 reports the selective explosions. The dimensions were obtained for sections on the basis of analyses of dead, live and seismic loading. The dead and live loadings were obtained based on figures presented in the previous section before and during static analysis, shear forces, and bending moments (anchors) of the members.

The seismic loading was exerted using equivalent-static method, in which the weight of the structure is based on gravity force resulting from dead load and a percentage of live load, with the earthquake coefficient being equal to 0.125. It was assumed that the structure was located in a region with a high seismic hazard on a soil bed of type 2, and the system was assumed to be resistant to lateral force with behavior factor of 7. The importance factor of 2 was assigned to the structure. In accordance with the earthquake code, the load was applied and the shear and bending moments (anchorage) were obtained using static analysis, according to which the sections were selected. Note that the initial estimation reported in Table 2 (accomplished based on observations and engineering judgments and work experiences) has indicated desirable resistance to earthquake, and thus they were selected as the main sections for the study. Further, appropriate and logical dimensions were selected for frames. Note that the present research did not aim at presenting a comparison between seismic and blast loads.

The blast loads were selected in such a way that they would not lead to formation of plastic hinge during analysis procedure of the explosions. It means that the structure would remain within the linear behavior range. The explosion was proportional to the structure, signifying that it occurred with an adequate severity and at a distance from the structure, so that the strike wave would not affect the entire structure (near blasts were not considered). The selected explosions would not result in great deformations in the members of the modeled frame during software analysis. The great deformations refer to those deformations causing collapse of the structure. Also, we tried to use explosions which would not lead to shear forces greater than shear capacity within the members of the modeled frame during software analysis. Using a step-by-step procedure recommended by UFC 3-340-02 and curves depicted by Figures 2, the loading phase was accomplished.

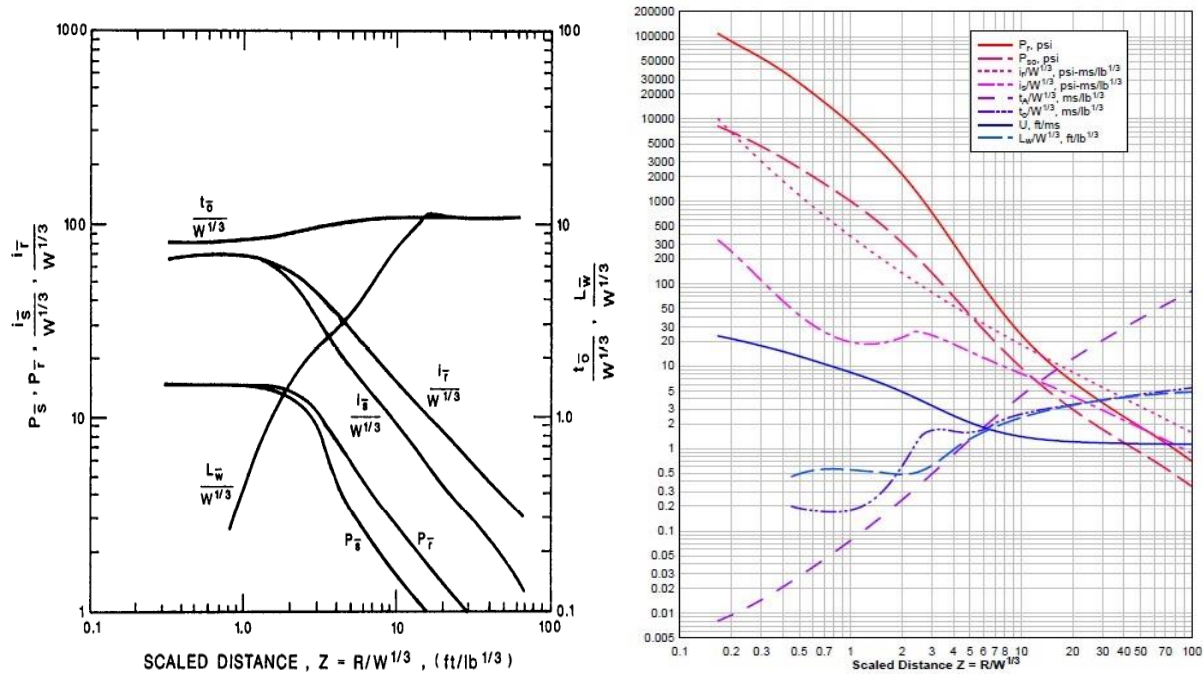

(a- Negative Phase)

(b- Positive Phase)

Figure 2. Shock Wave Parameters for a Hemispherical TNT Explosion at the Sea Level [18]

### 4. Results and Discussion

After structure modeling, loading, and module linear time history dynamic analysis, the output results were obtained based on three parameters, with the final conclusion made based on these values. The output results involved lateral drift, lateral velocity, and lateral acceleration of the stories. The results were presented in two forms known as maximum values and timed response. The results obtained for the lateral drift were used for controlling the structure health, with the lateral acceleration output results used for the health and convenience of the building residents. The results obtained for lateral velocity were used for determining the projectile range detaching from facades. The results are presented based on the variations in blasts and stories count.

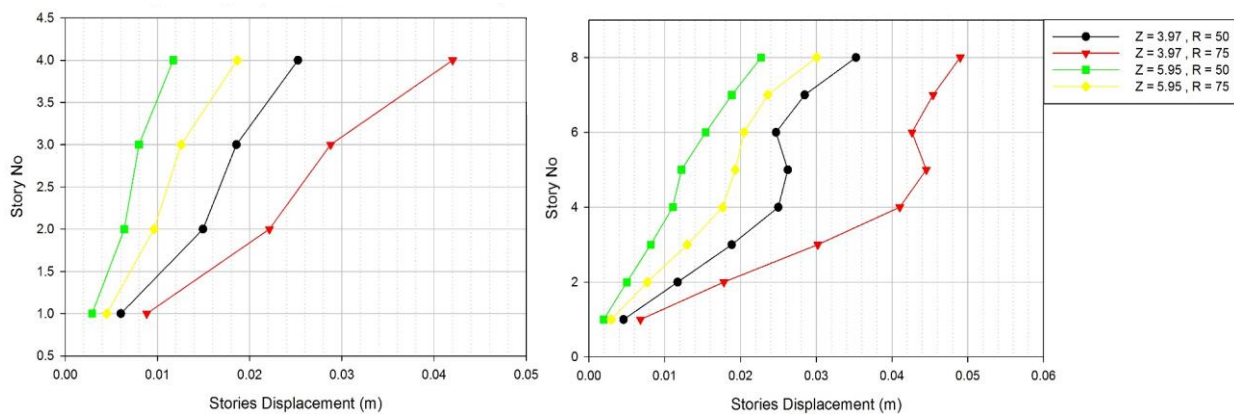

(a) 4-story building

(b) 8-story building

Figure 3. Maximum lateral drift of stories subjected to selective blasts

The lateral drift of stories decreased during the occurrence of blasts with greater scaled distance. During the explosions with a constant scaled distance, as the distance rose, the value of lateral drift also increased. If the scaled distance of both blasts was the same, the maximum reflected compression would be also the same, and most distance blasts would lead to greater reflective momentum.

Tables 3 present the maximum lateral acceleration for 4-story and 8-story building, respectively. It is obvious that the maximum lateral acceleration is a function of the scaled distance and any variations in the scaled distance would lead to the same extent of change in all stories.

**Table 3. Maximum lateral acceleration of stories**

4 Story MAX Acceleration under explosions				
Stories	Explosion1 (3.97,50 m)	Explosion2 (3.97,75 m)	Explosion3 (5.95,50 m)	Explosion4 (5.95,75 m)
1	33.00315	33.00315	14.2289	14.2289
2	33.41555	33.41555	14.40671	14.40671
3	34.63488	34.63488	14.9324	14.9324
4	18.32796	18.32796	7.90187	7.90187

  

8 Story MAX Acceleration under explosions				
Stories	Explosion1 (3.97,50 m)	Explosion2 (3.97,75 m)	Explosion3 (5.95,50 m)	Explosion4 (5.95,75 m)
1	17.26798	17.26798	7.44488	7.44488
2	35.39771	35.39771	15.26129	15.26129
3	34.55131	34.55131	14.89637	14.89637
4	27.96854	27.96854	12.05829	12.05829
5	32.29161	32.29161	13.92213	13.92213
6	37.71222	37.71222	16.25916	16.25916
7	30.45834	30.45834	13.13174	13.13174
8	19.98236	19.98236	8.61515	8.61515

Comparing the results of analysis and values presented by previous studies, it is obvious that all maximum accelerations have been greater than acceleration degree 8 (see Table 1). The lateral accelerations of stories varied within the range of 0.7 g and 3.8 g. These accelerations are almost equal to accelerations resulting from car accidents and can lead to significant damages to the building residents. For more accurate judgments regarding lateral accelerations of stories, the results obtained for timed lateral accelerations of the stories are presented by Figures 4 and 5. Note that the results involve two phases: in the first phase, the lateral accelerations reach their maximum value within a short period of time, after which they mitigate rapidly. In the second phase, the acceleration varies in accordance with free vibration. The middle area of two phases experiences high turbulence.

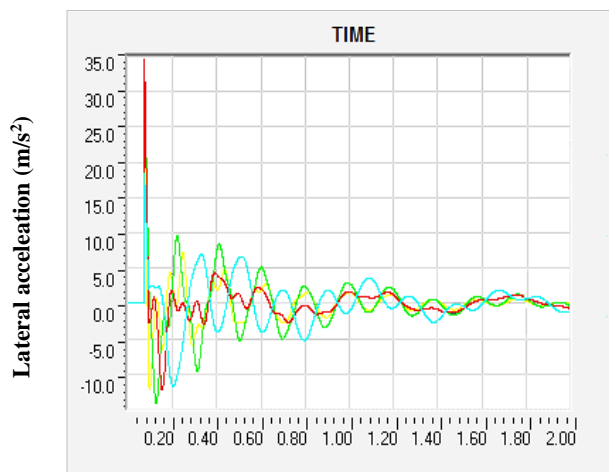

Time (s)  
a) Blast type I

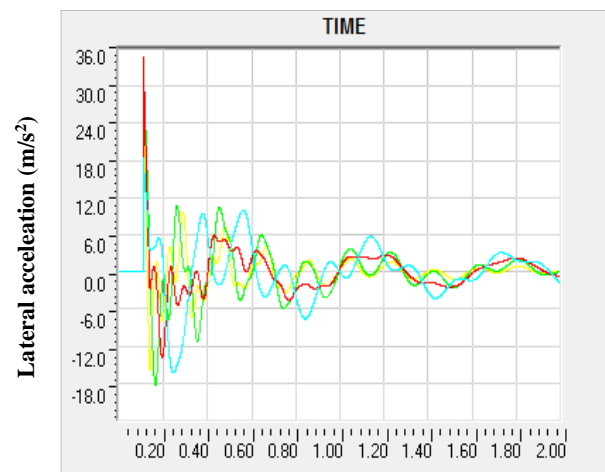

Time (s)  
b) Blast type II

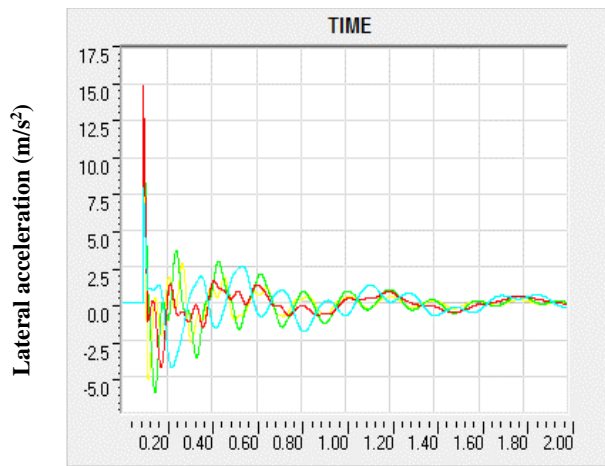

c) Blast type III

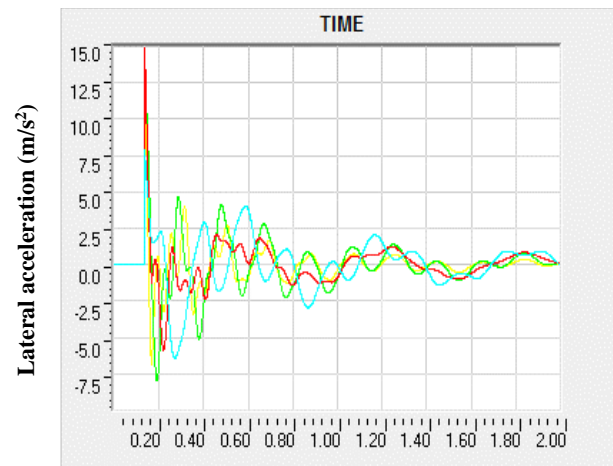

d) Blast type IV

Figure 4. Time history lateral acceleration of the 4-story building subjected to various blast types; each color line indicates a point on a floor: Yellow: 1<sup>st</sup>, Green: 2<sup>nd</sup>, Red: 3<sup>rd</sup>, Cyan: 4<sup>th</sup>.

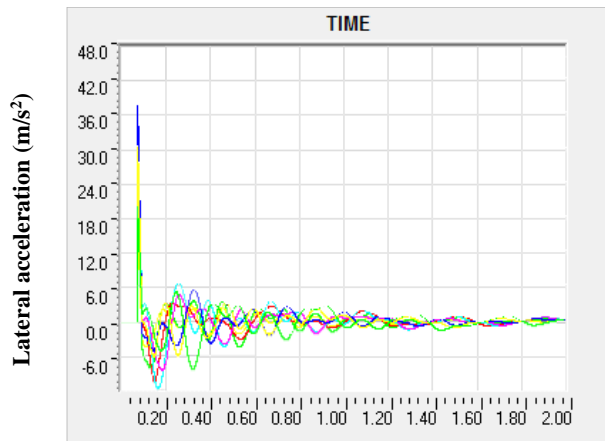

a) Blast type I

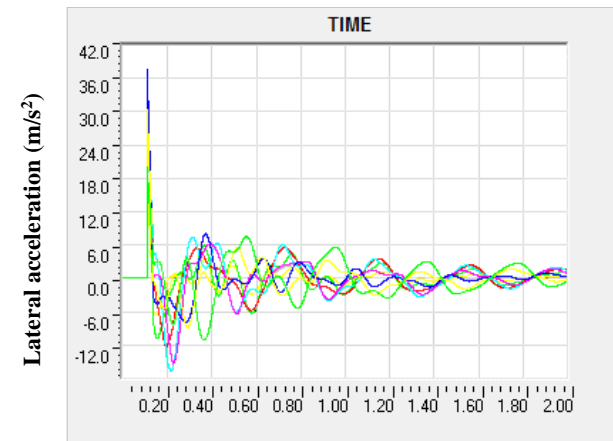

b) Blast type II

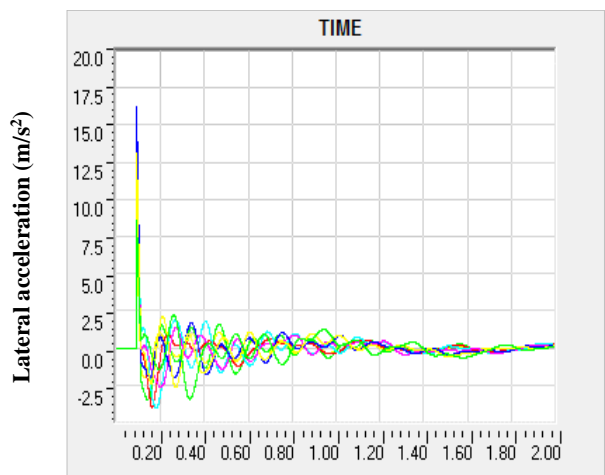

c) Blast type III

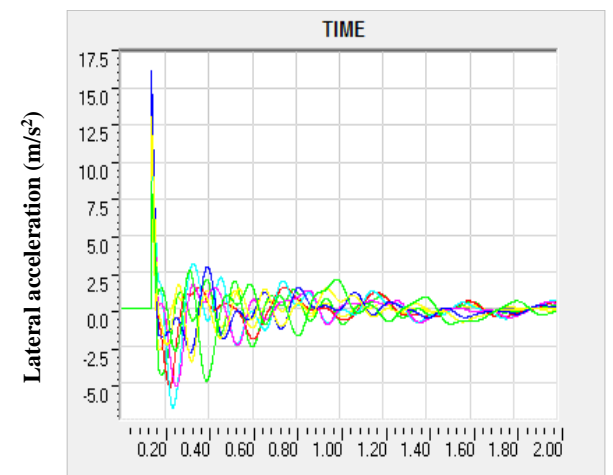

d) Blast type IV

Figure 5. Timed acceleration of 8-story building subjected to various blast types; each color line indicates a point on a floor: Yellow: 1<sup>st</sup>, Green: 2<sup>nd</sup>, Red: 3<sup>rd</sup>, Cyan: 4<sup>th</sup>, Magneta: 5<sup>th</sup>, Blue: 6<sup>th</sup>, Wide-yellow: 7<sup>th</sup>, Wide-green: 8<sup>th</sup>.

As can be seen, during occurrence of explosions with the same scaled distance, merely the lateral accelerations of the stories are the same, while the accelerations of stories will be different for various times. The time accelerations are greater than 8 degree for the first second of vibration (see Table 1), indicating disruption of the balance and potentially



damage to the residents.

Finally, with regard to the maximum lateral velocity obtained for stories, kinematic questions regarding the motions of projectiles, and the assumption that the detached elements are detached from the building at the moment when the velocity is maximum, it can be concluded that the range of detached projectiles can be calculated. Tables 6 and 7 present these values. The range of projectile is a function of the maximum velocity and height of the considered story. It was assumed that the projectile is thrown within the equilibrium range of the considered story.

**Table 4. Maximum range of projectile detached from alignment level balance of the stories under the impact of all blasts**

4 Story MAX Projectile Range under Explosions				
Stories	Explosion1 (3.97,50)	Explosion2 (3.97,75)	Explosion3 (5.95,50)	Explosion4 (5.95,75)
1	0.195437266	0.246975144	0.084228065	0.106516829
2	0.402363719	0.594144558	0.173531797	0.256150185
3	0.431024468	0.615787942	0.185847131	0.265495901
4	0.704012111	1.110840704	0.205369452	0.342543107
8 Story MAX Projectile Range under Explosions				
Stories	Explosion1 (3.97,50)	Explosion2 (3.97,75)	Explosion3 (5.95,50)	Explosion4 (5.95,75)
1	0.115901572	0.155239285	0.049973755	0.066944498
2	0.3500498	0.481000499	0.150858745	0.207375474
3	0.459199543	0.67687909	0.198038269	0.291774577
4	0.581071982	0.868401519	0.248539268	0.376484592
5	0.576036123	0.868775792	0.246572839	0.376679359
6	0.685995185	0.985986378	0.295776757	0.425083305
7	0.627156717	0.93421728	0.270436763	0.402861804
8	0.679085552	1.485361394	0.312335114	0.412096542

## 5. Conclusion

The 1<sup>st</sup> mode load distribution pattern result in the lowest target shear capacity and the largest target displacement demand, therefore, it mostly was the control load pattern, and as stated in FEMA 440, "the 1<sup>st</sup> mode load distribution is recommended".

In the 4-storey building, the maximum lateral drift revealed a 1.5-fold increase, during the explosions with a constant scaled distance, as the explosion distance experienced 1.5-fold increase. In addition, within a constant interval, as the scaled distance exhibited 1.5-fold increase, the maximum lateral drift of stories witnessed a 0.45-fold increase. In all of these cases, the limitation of lateral drift was less than 0.5% of the height of the floors. In the 8-story building, the maximum lateral drift of the stories indicated a 1.4-fold increase, during the explosions of constant scaled distance, as the explosion distance experienced 1.5-fold increase, and in the explosions of 1.5-fold increase in the constants distance, the lateral drift experience a 0.6-fold growth. In the 8-story building, limitation of lateral drift of the stories was also present. In all of these cases, the lateral drift was within the permissible range.

The maximum lateral acceleration of stories was only a function of scaled distance, where this parameter was the same for the same scaled distances (intervals). With variations in the distance of explosions, the maximum lateral acceleration of the stories did not change in the same scaled-distance. In all buildings, as the scaled-distance experienced 1.5-fold increase, the maximum lateral acceleration found a 0.43-fold rise. This suggested that the lateral maximum acceleration of the stories is independent of stories count and the geometrical shape of the building. With regard to the values obtained for the maximum lateral acceleration of the stories, these values varied between 0.7 g and 3.8 g, which were greater than the tolerance threshold of the building residents. In this case, the residents' balance was disrupted and any injury resulting from projectiles could not be avoided. Notably, these values of the acceleration are equal to the accelerations induced during car accidents, leading to residents' injury.

According to the Tables 3, the maximum range of the projectiles detaching from the building façade was almost equal to 1.5 m. This value is used for determining the margin of safety of the building. Note that determination of the margin of safety requires applying further blasts and it is not possible to state a reliable statement about the safety margin

merely by applying 4 explosions. As the main conclusion of the research, although the building was safe against the elective blasts, the lateral accelerations were capable of imposing significant damages to the building residents, which can be considered as a criterion for control and future designs.

## 6. Conflict of Interest

The authors declare no conflict of interest.

## 7. References

- [1] Tadepalli, T., and C. Mullen. "Design Parameters Governing Performance of Low Rise Reinforced Concrete Frame Structures Subjected to External Blast Loading." Structures Congress 2008 (October 14, 2008). doi:10.1061/41016(314)197.
- [2] Ngo, Tuan, Priyan Mendis, Anant Gupta, and J. Ramsay. "Blast loading and blast effects on structures—an overview." Electronic Journal of Structural Engineering 7, no. S1 (2007): 76-91.
- [3] Bao, Xiaoli, and Bing Li. "Residual Strength of Blast Damaged Reinforced Concrete Columns." International Journal of Impact Engineering 37, no. 3 (March 2010): 295–308. doi:10.1016/j.ijimpeng.2009.04.003.
- [4] Clevenston, Sherman A., Thomas K. Dempsey, and Jack D. Leatherwood. Effect of vibration duration on human discomfort. Vol. 1283. National Aeronautics and Space Administration, Scientific and Technical Information Office, 1978.
- [5] Naeim, Farzad. Design practice to prevent floor vibrations. Steel Committee of California, 1991.
- [6] Boyd, Stephen D. Acceleration of a plate subject to explosive blast loading-trial results. No. DSTO-TN-0270. Defence Science and Technology Organisation Melbourne (Australia), 2000.
- [7] Crawford, H. "Survivable impact forces on human body constrained by full body harness." UK Health and Safety Executive (2003).
- [8] Voshell, Martin. "High acceleration and the human body." 28th November (2004).
- [9] Mendis, Priyan, T. D. Ngo, N. Haritos, Anil Hira, Bijan Samali, and John Cheung. "Wind loading on tall buildings." Electronic Journal of Structural Engineering (2007).
- [10] Kwok, Kenny C.S., Peter A. Hitchcock, and Melissa D. Burton. "Perception of Vibration and Occupant Comfort in Wind-Excited Tall Buildings." Journal of Wind Engineering and Industrial Aerodynamics 97, no. 7–8 (September 2009): 368–380. doi:10.1016/j.jweia.2009.05.006.
- [11] Ferrareto, Johann Andrade. "Human Comfort in Tall Building's subjected to Wind-Induced Motion." (n.d.). doi:10.11606/t.3.2017.tde-17072017-105508.
- [12] Mansfield, Neil J. "Human Response to Vibration." Edited by Neil J. Mansfield (October 28, 2004). doi:10.1201/b12481.
- [13] Ragunath Sankaranarayanan, Seismic Response of Acceleration-Sensitive Nonstructural Components Mounted on Moment-Resisting Frame Structures, (2007).
- [14] Daryl Boggs, Acceleration Indexes for Human Comfort in Tall Buildings-Peak or RMS?, Cermak Peterka Petersen, Inc. , (1995).
- [15] Noss, Nicholas. "Investigation of Human-Structure Interaction through Experimental and Analytical Studies." (2012). Master's Theses.
- [16] Jónsson, Örvar. "The dynamic behaviour of multi-story reinforced concrete building in a seismic and windy environment." Reykjavik, University of Reykjavik (2014).
- [17] Pacific Earthquake Engineering Research Center. Guidelines for performance-based seismic design of tall buildings. Pacific Earthquake Engineering Research Center, College of Engineering, University of California, 2010.
- [18] Structures To Resist The Effects Of Accidental Explosions, U.S. Army Corps Of Engineers, Naval Facilities Engineering Command, Air Force Civil Engineer Support Agency, Unified Facilities Criteria (UFC), (2008).
- [19] Gao, Feng, Li Lin Cao, and Xing Hua Li. "Study on Human-Structure Dynamic Interaction in Civil Engineering." Edited by M. Mostafa. E3S Web of Conferences 38 (2018): 03013. doi:10.1051/e3sconf/20183803013.
- [20] Bulushev, Sergey, and Artem Bunov. "Dynamic Analysis of Strength and Human-Comfort Level of the Football Stadium Structures at Coordinated Movements of Audience." Edited by V. Andreev, T. Matseevich, A. Ter-Martirosyan, and A. Adamtsevich. MATEC Web of Conferences 196 (2018): 02032. doi:10.1051/matecconf/201819602032.
- [21] Scheu, Matti, Denis Matha, Marie-Antoinette Schwarzkopf, and Athanasios Kolios. "Human Exposure to Motion during Maintenance on Floating Offshore Wind Turbines." Ocean Engineering 165 (October 2018): 293–306. doi:10.1016/j.oceaneng.2018.07.016.
- [22] Zeinab Khaksar, Numerical Modelling of the Effects of Vibration in Helicopters for Prediction and Analysis of Human Comfort Assessment, University of New South Wales, A thesis in fulfilment of the requirements for the degree of Doctor of Philosophy, 2018.
- [23] Gräbe, Roland Peter. "Ride comfort difference thresholds for a vehicle on a 4-poster test rig." PhD diss., University of Pretoria. (2017).