

A Parametric Study on the Flexural Strengthening of Reinforced Concrete Beams with Near Surface Mounted FRP Bars

Minu Panahi ^{a*}, Mohsen Izadinia ^b

^a M.Sc. Graduate, Department of Civil Engineering, Islamic Azad University, Najafabad Branch, 8514143131, Najafabad, Iran.

^b Assistant Professor, Department of Civil Engineering, Islamic Azad University, Najafabad Branch, 8514143131, Najafabad, Iran.

Received 22 December 2017; Accepted 17 July 2018

Abstract

FRP rods as lightweight materials with extraordinary properties of high strength to weight ratio, corrosion resistance, potentially high overall durability, tailor ability and high specific attributes are one of the most favorable materials to strengthen existing reinforced structures. The present study aimed to identify the behavior of reinforced concrete flexural beams strengthened with fiber reinforced polymer (FRP) rods through near surface mounted method (NSM). The results of the current study were based on nonlinear finite element software ABAQUS which can accurately simulate the experimental investigations on flexural behavior of reinforced concrete beams strengthened with NSM FRP rods. Validation of the proposed model was confirmed first by making a comparison with the experimental study presented in the literature. A parametric analysis was conducted on validated specimens to investigate the effect of FRP rod diameters, rod arrangements, FRP materials, as well as rods groove intervals on flexural behavior of strengthened reinforced beams. The numerical results of mid-span bending moment deflection, ultimate bending moment, failure deflection and ductility index were reported. For the sake of simplicity to be used by engineers, the results of the current study were drawn in the form of design charts and tables.

Keywords: Flexural Strengthening; Near Surface Mounted (NSM); Fiber Reinforced Polymer (FRP) Bars.

1. Introduction

The apprehensive statistics of human losses and financial casualties induced by poor performance of existing structures have doubled the importance of urgent demand to strengthen reinforced concrete structures due to either a change in use or structural degradation. Deterioration of concrete, bars corrosion, physical damages, aging of concrete structures, upgrading the design standard codes, exposure of unpredictable loads such as severe strong earthquakes and shock loads, committing imperfections and errors in design and construction procedures, and changes in the use of a structure are some of the most well-known reasons of strengthening reinforced concrete structures among many [1-3]. All of these broad classifications of structural deficiency can be addressed using FRP composites.

An impressive technique to enhance the load-carrying capacity and serviceability of existing reinforced concrete structures is using Fiber Reinforced Polymer (FRP). Fiber reinforced polymer is formed by embedding continuous fibers in a polymeric resin matrix. Application of FRP as retrofitting material received a great acceptance from engineers as an alternative for other strengthening methods due to their priority and great advantages. The fiber reinforced polymer (FRP) composites as strengthening materials have the advantages of the minimal increase in the dead load of structure, high strength to weight ratio, corrosion resistance, and durability performance which enable them to be used in areas

* Corresponding author: minupanahi@yahoo.com

 <http://dx.doi.org/10.28991/cej-03091126>

➤ This is an open access article under the CC-BY license (<https://creativecommons.org/licenses/by/4.0/>).

© Authors retain all copyrights.

where the conventional construction materials might be restricted [4, 5]. Despite the disadvantages of using FRP including lack of ductility and quick softening at high temperatures, strengthening existing reinforced concrete structures with FRP is known as one of the most cost-effective strengthening solutions [2]. In addition, strengthening existing concrete structures with the fiber reinforced polymer (FRP) outperforms steel sheet, a conventional retrofitting technique, due to the fact that steel sheets are exposed to corrosion, detachment, and the weight of steel sheets in large span beams is problematic. Along with that, the successful use of FRP in many fields on engineering namely, aerospace, and automobile industries makes the application of FRP superior to steel sheets due to the lower future maintenance and repair costs. Therefore, fiber reinforced polymers (FRP), as far as repairing and retrofitting structures is concerned, are more common compared to traditional building materials such as steel sheets.

Over the several last decades, strengthening of existing structures including reinforced concrete beams, slabs, walls and columns through the externally bonded reinforcement (EBR) and the near surface mounted (NSM) methods with fiber reinforced polymer (FRP) has been successfully utilized in civil engineering applications due to its efficiency, effectiveness and ease of application for strengthening concrete structures in both flexure and shear. A laminate or textile bond onto the surface of concrete elements in externally bonded method (EPR) while the near surface mounted method consists of placing fiber reinforced polymer bars into grooves precut on the concrete members and embedding them with a high-strength adhesive [6]. The efficiency of using FRP for strengthening of reinforced members according to the near surface mounted (NSM) method is widely proven in comparison to the externally bonded reinforcement (EBR) due to the fact that, the tensile strength of fiber reinforced polymer is better exploited [7]. Moreover, application of fiber reinforced polymer (FRP) with the near surface mounted (NSM) method is an alternative to the externally bonded reinforcement technique to mitigate the risk of premature debonding failure [8, 9], deterioration of FRP materials, protection against environmental corrosion and temperature, better aesthetics, as well as delimit any imperfection accommodate to the installation procedure [10, 11]. Fracture of flexural components (FRP materials), detachment of FRP sheets from the structural elements and flaking of concrete in EBR scheme of strengthening lead an additional difficulty arising from the fact that only limited amount of FRP can be used to increase the beam flexural capacity [12]. However, application of near surface mounted technique is appropriate only if the cover of the internal reinforcement is sufficiently thick for the groove size to be accommodated [5]. It worth mentioning that, the performance of the near surface mounted bars in strengthening of existing reinforced concrete elements is affected by local bond slip behavior, surface characteristics of FRP bars and treatments of reinforcement and grooves, interactions of FRP rods with the surrounding materials, geometry of FRP bars, and the concrete cover [7, 13].

The first documented use of fiber reinforced polymer (FRP) was for construction of a dome in Libya in 1986. From the mid-1980s and continuing to the present time numerous structures were repaired or strengthened with FRP materials. Hence, a great number of researchers have studied the effective factors affecting the efficiency of application FRP with different techniques like NSM and EBR via various methods and solutions. Experimental studies of Al-Mahmoud et al. [14], Barros and Fortes [15] Bilotta et al. [6, 7, 9], Grace et al. [2], Lee et al. [16], Lu et al. [17], Novidis et al. [13], Rizzo, and De Lorenzis [18], Sharaky et al. [11, 19-21], Tang et al. [22], Wang et al. [23], Wu et al. [24] and numerical analyses of Bianco et al. [25, 26], Coelho et al. [27], Hawileh [28], Kara et al. [29], Kaveh et al. [30], Seo et al. [31], Sharaky et al. [20], Teng et al. [32], Zhang et al. [33] are some of the most recent and pioneer studies in the field of strengthening existing structures with FRP according to the near surface mounted (NSM). Despite the fact that innumerable recent studies devoted at appraising the potentialities of strengthening existing structures with FRP, nevertheless limited design guidelines are currently available for either the externally bonded reinforcement or near surface mounted strengthening technique. On the other hand, the application of these guidelines is often complicated and involves a lot of limitations, so it is of practical significance to conduct more studies on fiber reinforced polymers (FRP), as far as repairing and retrofitting structures are concerned.

The aim of this study is to investigate flexural strengthening of reinforced concrete beams with near surface mounted FRP bars. For this purpose, numerical investigations were conducted by finite element software ABAQUS 6.11 [34]. The solutions were compared to those presented in literature, and the influence of effective factors including, FRP rods diameter, arrangement, groove intervals and rods materials on the load carrying capacity of reinforced concrete beams sustained a concentrated load was then investigated. For the sake of simplicity to be used by engineers, the results of the current study were drawn in the form of design charts and tables.

2. Experimental Set-up

The validity of the results can be verified by comparing the results of numerical analyses presented herein with an experimental study conducted by Al-Mahmoud et al. [14]. Al-Mahmoud et al. [14] studied the effect of NSM FRP rods on the load carrying capacity of seven different configurations of strengthened reinforced concrete beams along with un-strengthened specimen. The reinforced concrete beams sustained increasing two-point loading (four point bending) up to the failure load of the specimens. The beam had a total length of 3000 mm (center to center distance of 2800 mm) and the cross-section dimensions of 280×150 mm as seen in Figure 1. The reinforced concrete beams consisted of two 12 mm bars in tension zone, as well as two 6 mm in diameter bars in compression zone and 6 mm diameter steel stirrups

spaced 150 mm apart. Figure 2 along with Table 1 demonstrate the tested specimens beam configuration, setup, dimensions, and reinforcement details.

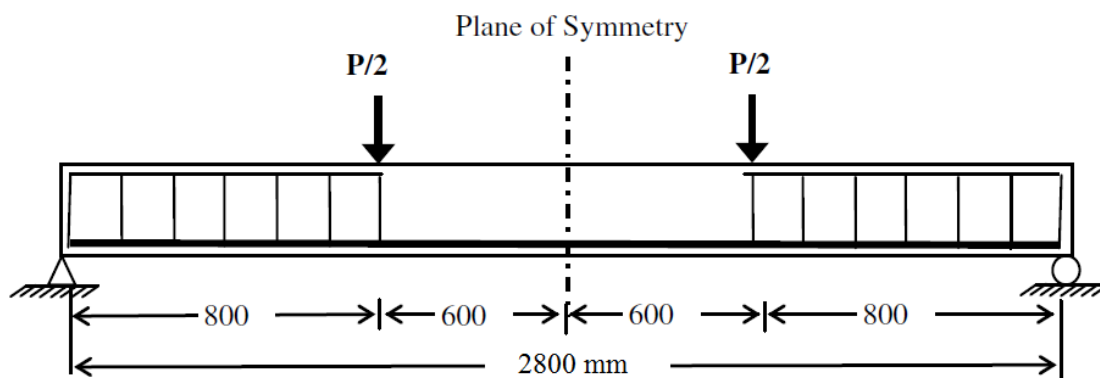

Figure 1. Longitudinal profile of reinforced concrete beam [14]

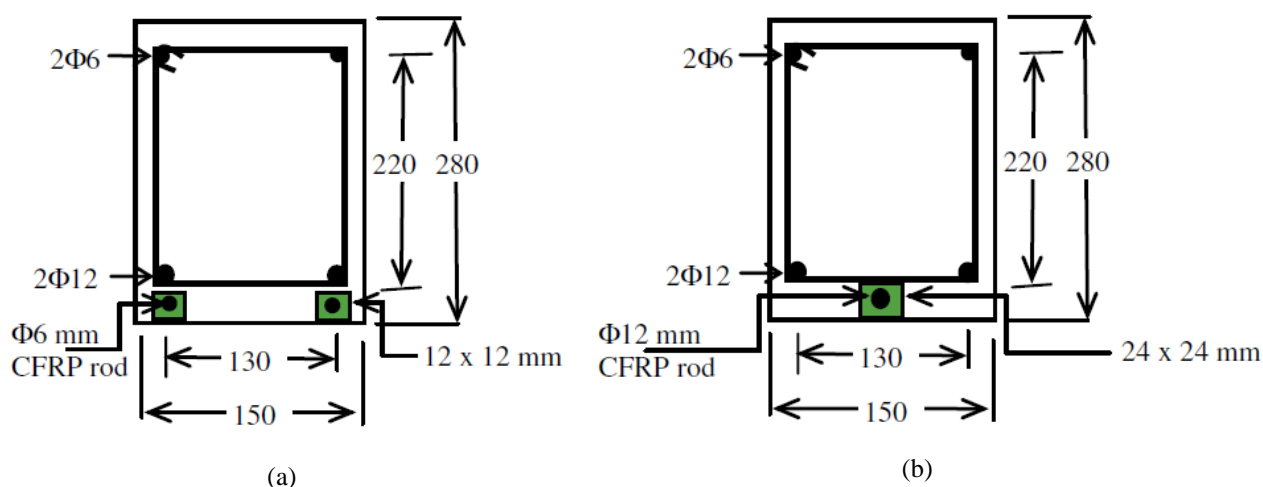

Figure 2. Beam cross section after strengthening with a) two 6mm CFRP rods b) one 12 mm CFRP rod [14]

Table 1. Material properties of beam specimen and filling material for validation of numerical analyses [14]

Beam material	Concrete strength	Compressive Strength (MPa)	Tensile Strength (MPa)	Elasticity Modulus (GPa)	FRP Length (mm)	No. of FRP bars	Filling material
Control beam	VC30	37.4	3.0	30.3	-	-	-
S-C 6 (VC30)	VC30	37.5	3.4	28.4	3000	2Φ6	Resin
S-C 6 (270-R)	VC30	36.5	3.2	27.9	2700	2Φ6	Resin
S-C 6 (210-R)	VC30	36.7	3.2	28.1	2100	2Φ6	Resin
S-C 6 (VC60)	VC630	66.5	5.4	41.3	3000	2Φ6	Resin
S-C 12 (VC30)	VC30	35.1	3.4	29.5	3000	1Φ12	Resin
S-C 12 (VC60)	VC60	67.2	5.6	40.5	3000	1Φ12	Resin
Epoxy Resin	-	83.0	29.5	4.94	-	-	-

As seen in Table 1, three type of variables including, CFRP rod cross-section, concrete strength (conventional (VC30) versus high-strength (VC60) concrete), and FRP rods configurations were investigated by Al-Mahmud et al. in 2009. The mechanical properties of the epoxy resin were measured at seven days for filling material, while the mechanical behavior of the concrete measured at 28 days for all the beam specimens [14].

3. Finite Element Modeling

3.1. Element Description

Three-dimensional scheme of finite element analysis was used to simulated reinforced concrete beams strengthening with NSM FRP rods in ABAQUS. Due to the symmetry of the geometry, loadings and boundary conditions in two perpendicular planes, only one-quarter of the beam was modeled. Modeling only one-quarter of reinforced concrete beam reduces the total number of the elements by four and therefore, it has the advantage of lessening the computational times and efforts tremendously. Eight nodes 3D brick elements (C3D8R) were employed to simulate the concrete and filling materials. This type of elements has the ability to model nonlinear behavior of concrete and filling materials. In addition, the capability of 3D brick elements (C3D8R) in simulating cracking and crushing in tension and compression regions makes it more favorable to use in finite element analysis [34]. Figure 3 illustrates the finite element model of concrete in ABAQUS.

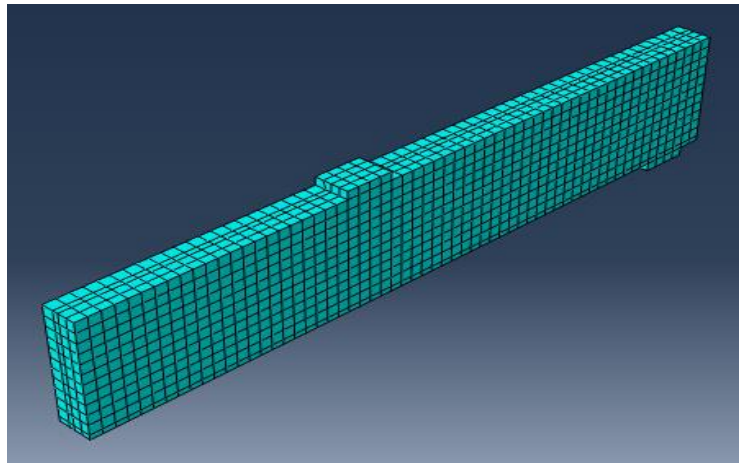

Figure 3. Three-dimensional eight-node element (C3D8R) used to model concrete beam

Two different approaches such as beam elements or truss elements can be used to simulate steel bar elements. In this study, the truss element with 3D mesh discretization (T3D2), was used for introducing the structural bars. Steel bars were introduced in one or several layers with a uniform distance. 3D truss element (T3D2) is a uniaxial tension-compression element with three translational degrees of freedom at each node. FRP rods were defined similarly to the steel bars elements [34]. Steel bars and FRP rods are fully embedded in the concrete and filling materials, respectively. Hence, the degrees of freedom of structural bars and FRP should not be independent to the degrees of freedom of the concrete and filling materials. Therefore, the assumption of the perfect bond between the reinforcement elements and concrete as well as between FRP rods and filling materials seems to be rational. This assumption ignores the development of both shear stresses in the interface of materials and slip between the reinforcement elements (bars and rods) and surrounding materials. In order to address this condition, the embedded region function of ABAQUS was used. Figure 4 shows the ability of ABAQUS to model different types of the elements through the embedded region function [34]. The interface of concrete and filling material was modeled using Tie interface elements. Tie interface elements are 3D zero thickness elements ignores any slip between two surfaces [34].

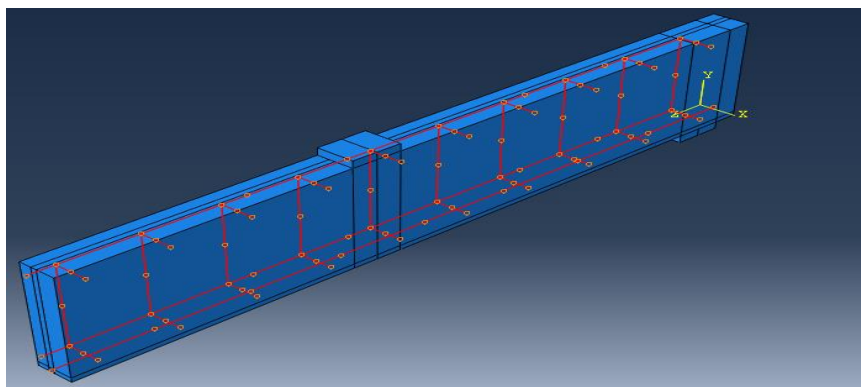

Figure 4. Finite element model of the embedded region function in ABAQUS

The applied load was in accordance with the experimental study of Al-Mahmud et al. (2009). As one-quarter of beams was modeled, only one-quarter of the sustained load was applied. Two rigid supports were also modeled, one acting as pin support and the other as roller support to allow deflection of beams (symmetry condition). Figure 5a and 5b show the finite element model schematically of and finite element simulation in ABAQUS.

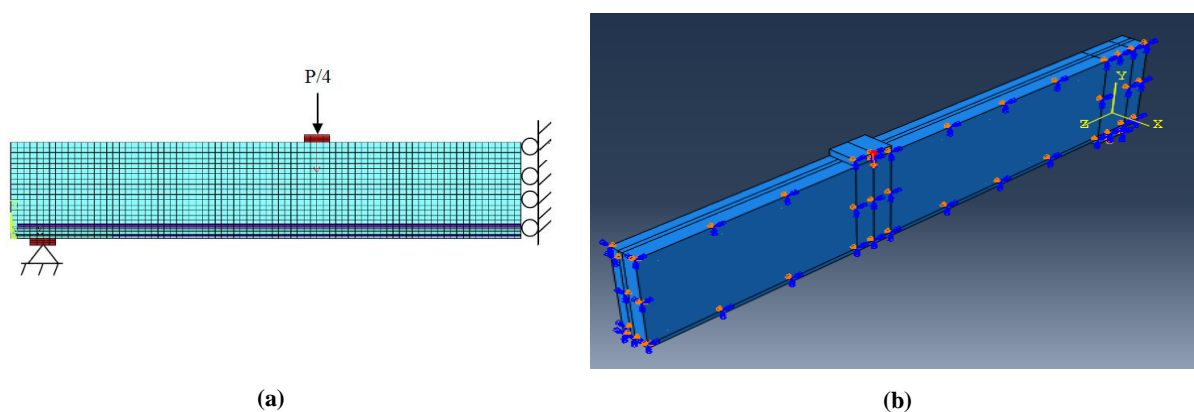

Figure 5. Demonstration of applied load a) Schematic model, b) Finite element simulation in ABAQUS.

3.2. Material Properties

The beams in the experimental study of Al-Mahmud et al. were cast using two vibrated concrete including conventional (VC30), and high-strength (VC60) concretes to investigate the effect of concrete compressive strength on the overall efficiency of specimens [14]. Tables 2 and 3 present the elastic and plastic properties of intended concretes, respectively. In order to define the plastic specification of concrete, damage plasticity model was used. The plastic parameters are the angle of dilation, the ratio of biaxial compressive strength to uniaxial compressive strength σ_{b0}/σ_{c0} , eccentricity (ϵ), shear strength ratio between two biaxial and tri-axial compression states (Ks), and viscosity as listed in Table 3. The nonlinear response of steel reinforcement bars was modeled by a bilinear elastoplastic model. In this method, the steel remains elastic up to the yield stress where plastic deformation occurs continuously. Table 4 lists the steel reinforcement parameters required for modeling.

Table 2. Elastic properties of intended concrete [14]

Concrete specimen	Elastic Modulus (MPa)	Compressive Strength (MPa)	Poisson's Ratio
VC30	28.4	37.5	0.2
VC60	41.3	66.5	0.2

Table 3. Plastic characteristics of intended concrete [14]

Concrete specimen	Angle of Dilation	σ_{b0}/σ_{c0}	Eccentricity	Ks	Viscosity
VC30	36	1.16	0.1	0.667	0.0005
VC60					

Table 4. Properties of intended steel bars [14]

Structural bars	Elastic Modulus (GPa)	Yield Stress (MPa)	Ultimate Strength (MPa)	Poisson's Ratio
	210	600	700	0.3

The brittle fracture model was used for simulating the behavior of FRP rods. In this method, it is assumed that the behavior of FRP sheets are linear until reaching the plastic strain, where cracks extend, and the FRP rods lose their load carrying capacity instantly. According to Table 5, the required parameters for this model are fiber polymers elasticity coefficient, Poisson's ratio, and tensile strength.

Table 5. Properties of intended FRP rods [14]

FRP	Elastic Modulus (MPa)	Tensile Strength (MPa)	Poisson's Ratio
	1875	146	0.22

4. Results and Discussion

4.1. Verification of the Finite Element Analysis of Bending Moment-Mid Span Deflection Response

In order to apprise the validity of the finite element model results of the reinforced concrete beam with NSM FRP rods to those obtained by experimental study of Al-Mahmud et al. (2009), a comparison was made on bending moment

mid-span versus deflection between numerical simulation and experimental results of strengthening beams. Superimposed on Figure 6 and Table 6 is the results of finite element analysis and experimental investigations.

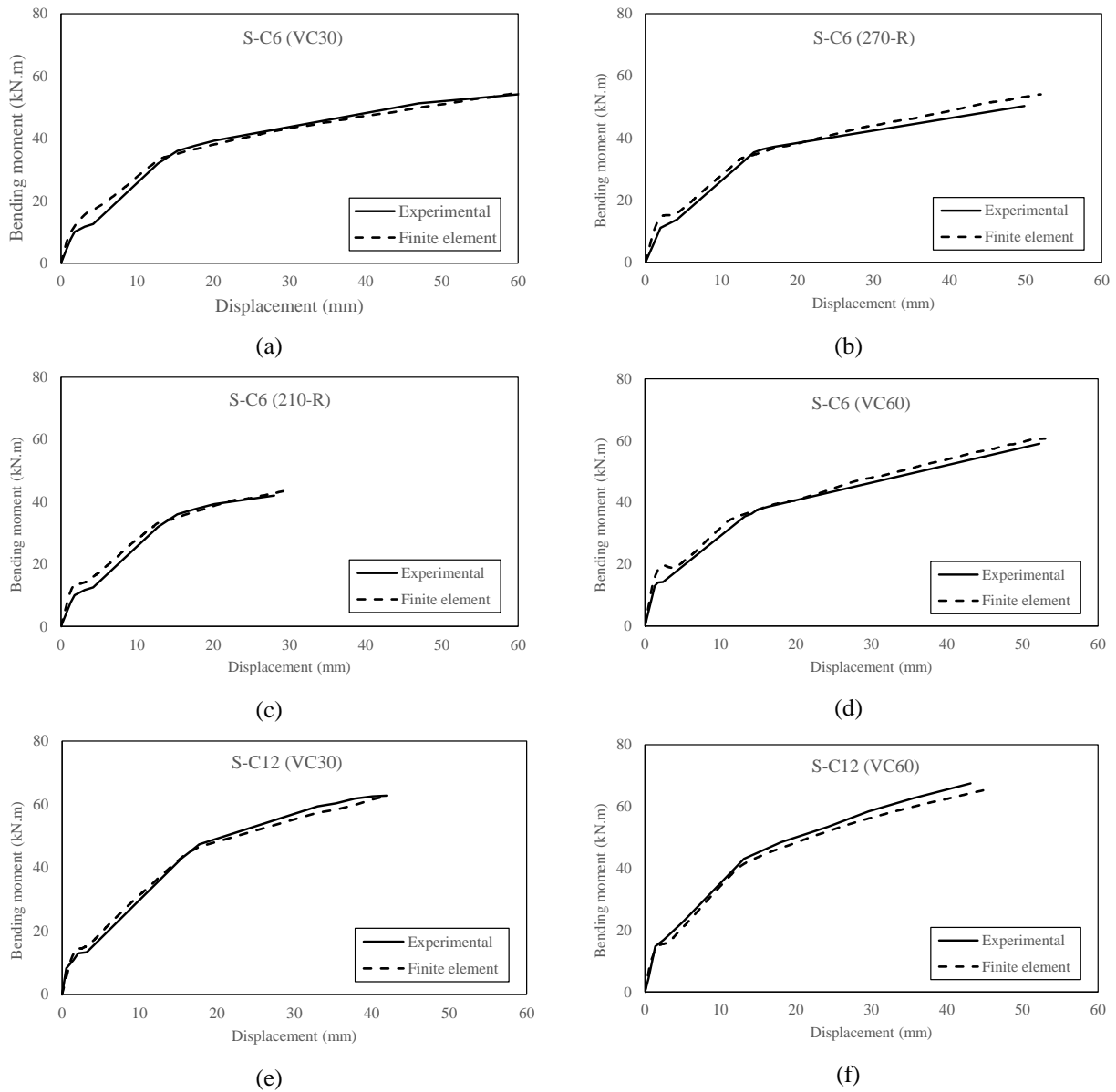

Figure 6. Validation of finite element analysis with experimental measurement of bending moment mid-span deflection for strengthening beams [14]

Table 6. Comparison of the results of finite element analysis and experimental measurement of bending moment mid-span deflection for strengthening beams [14]

Beam's Property	Concrete Cracking Moment (kN.m)		Steel Yielding Moment (kN.m)		Ultimate Bending Moment (kN.m)	
	Experimental	Numerical	Experimental	Numerical	Experimental	Numerical
S-C 6 (VC30)	8	7.8	35.2	36	58.5	58
S-C 6 (270-R)	7.4	8	36.8	35.5	53.3	53
S-C 6 (210-R)	8.1	8	38.2	35	44	43.8
S-C 6 (VC60)	12.3	12	36.9	36	59.2	57.8
S-C 12 (VC30)	7.8	8	47.77	47	65.4	62.88
S-C 12 (VC60)	11.6	10.8	44.8	42.47	73.2	66.96

The results are in good agreement with each other and consistency of the results confirmed the efficiency of finite element analysis of ABAQUS in modeling reinforced concrete beams strengthened with NSM FRP rods.

4.2. Parametric Study

A parametric study was conducted to investigate the effect of different parameters including the FRP rod diameter, the arrangement of FRP rods, groove intervals as well as FRP material on the flexural behavior of strengthened reinforced concrete beams with NSM FRP rods. The results of the parametric study are shown in the form of design charts and tables for the sake of simplicity to be used by engineers.

4.2.1. Effect of FRP Rods Diameter

The effect of FRP diameter size was numerically investigated on the validated model of S-C12 (VC30) specimen. The intended model consists of one groove in the bottom middle of beam strengthened with one 12 mm FRP bar. Five different numerical models with different FRP diameter sizes namely 6, 8, 10, 12, and 14 mm were built to study the effect of FRP bar diameter size and also the increasing rate of flexural capacity in strengthened beams compared to the control sample. The bending moment mid-span displacement, ultimate load (bending moment), and deflection at failure are presented in Figure 7 and Table 7, respectively. The ultimate load carrying capacity of the strengthened beams increases with an increase in FRP rod diameter. In addition, the failure deflection and consequently the ductility index of strengthened beams decreases with an increase in FRP rod diameter. Figures 8 and 9 illustrates the variation of normal stresses (S33) induce by bending moment and deflection of a strengthened beam with one 14 mm FRP bar.

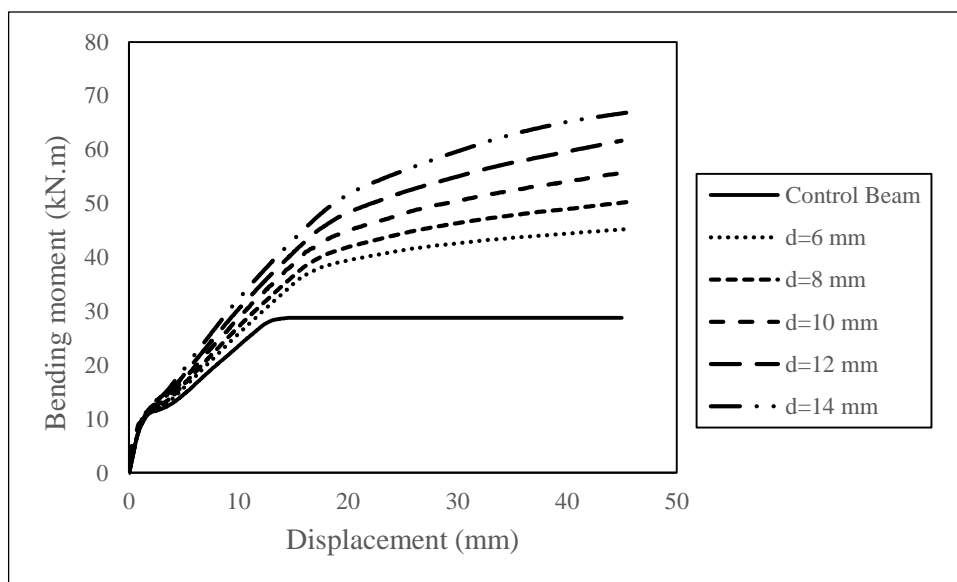

Figure 7. Variation of bending moment mid-span versus displacement for different FRP rod diameter

Table 7. Parametric results on the effect of different FRP bar sizes

FRP Rod Diameter (mm)	Steel Yielding Moment (kN.m)	Ultimate Bending Moment (kN.m)	Ultimate Deflection (mm)	Ductility Index
Without FRP	28.76	28.76	51	4.25
6	37.69	45.88	50.07	3.33
8	39.55	51.19	49.41	3.29
10	42.94	56.78	48.52	3.23
12	47.00	62.88	48.09	3.20
14	49.53	67.54	47.70	3.16

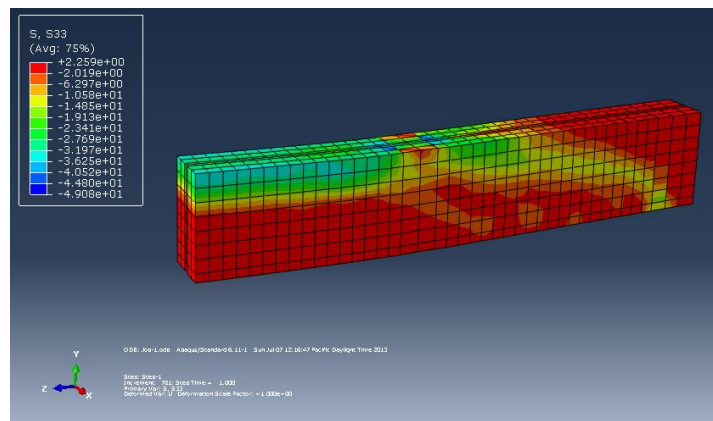

Figure 8. Normal stresses (S33) of the strengthened beam with one 14 mm FRP rod

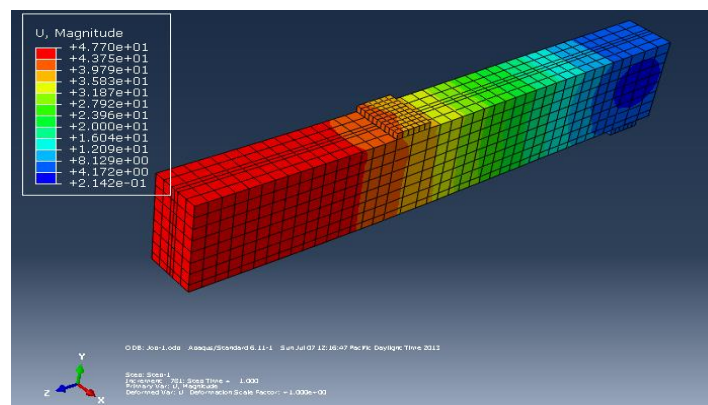

Figure 9. Ultimate deflection of the strengthened beam with one 14 mm FRP rod

4.2.2. Effect of FRP Rods Arrangement

The effect of FRP arrangement was investigated on specimens with constant values of FRP cross-section and different configurations. Three different numerical models with equivalent cross sections of 113.1 and 201.06 mm² were built to investigate the effect of FRP arrangement. Figure 10 and Table 8 illustrate the results of bending moment mid-span deflection, failure load and deflection of strengthened beams by 1, 2 and 3 rods with a total cross-section of 113.1 mm². Figure 11 along with Table 9 represent the results of the specimen with a total cross-section of 201.06 mm². It can be deduced by comparing the results presented in Figures 10, 11 and Tables 8, 9 that the bending moment mid-span deflection response, failure deflection as well as ductility are less affected by different arrangements of FRP rods. It is further observed that the ultimate bending moment increases with an increase in the total cross section of FRP rods. Nevertheless, the failure deflection and ductility have decremental trend by increasing FRP rods.

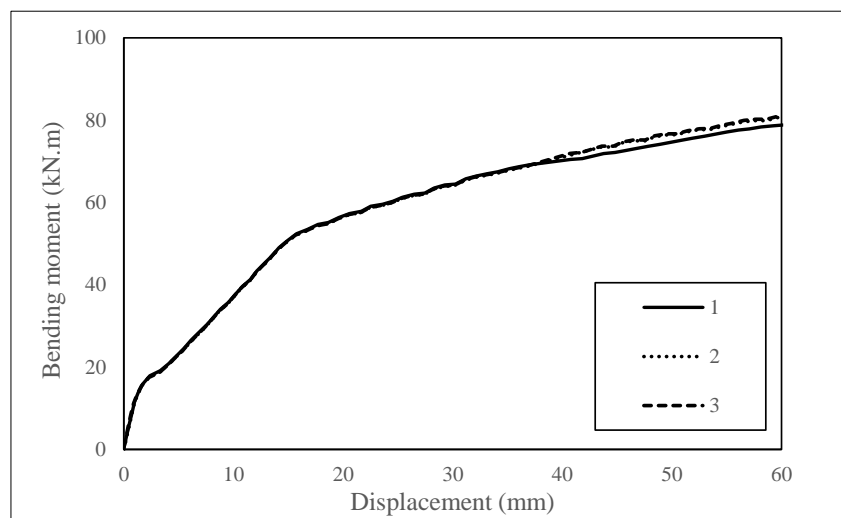

Figure 10. Variation of bending moment mid-span versus displacement for different FRP rod arrangement and a total cross-section of 113.1 mm²

Table 8. Parametric results of strengthened beams with a total cross-section of 113.1 mm²

Number of FRP Rods	Steel Yielding Moment (kN.m)	Ultimate Bending Moment (kN.m)	Ultimate Deflection (mm)	Ductility Index
1	52.70	79.54	60.05	5.61
2	52.53	80.42	60.28	5.74
3	52.77	81.09	60.19	5.79

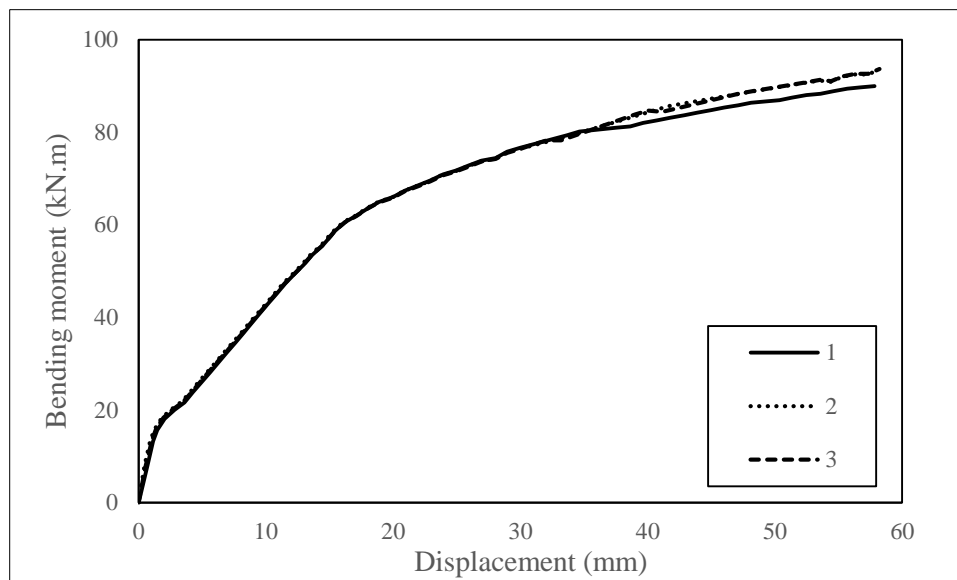

Figure 11. Variation of bending moment mid-span versus displacement for different FRP rod arrangement and a total cross-section of 201.06 mm²

Table 9. Parametric results of strengthened beams with a total cross-section of 201.06 mm²

Number of FRP Rods	Steel Yielding Moment (kN.m)	Ultimate Bending Moment (kN.m)	Ultimate Deflection (mm)	Ductility Index
1	62.16	91.79	57.86	3.40
2	61.88	93.52	58.76	3.45
3	62.58	94.57	58.69	3.43

4.2.3. Effect of FRP Material

The effect of different type of FRP materials on flexural behavior of strengthened reinforced beam was investigated by finite element software ABAQUS. For this purpose, three different FRP materials including Carbon Fibers Reinforced Polymer (CFRP), Glass Fiber Reinforced Polymer (GFRP) and Aramid Fiber Reinforced Polymer (AFRP) were chosen. The validated finite element strengthened beam model of S-C6 (270R) was selected as a benchmark. The properties of CFRP, GFRP, and AFRP are listed in Table 10.

Table 10. Properties of different FRP materials

FRP Material	Ultimate tensile strength (Mpa)	Ultimate strain (%)	Elastic modulus (GPa)	τ_{max} (Mpa)	Su (mm)
CFRP	1875	1.2	146	15.24	0.11
GFRP	825	2	40.8	12.48	0.13
AFRP	1480	2.1	68.6	12.08	0.1=20

Figure 12 and Table 11 show the results of bending moment mid-span against deflection, the ultimate tensile strength of reinforcement, failure moment and deflection, as well as ductility index. It can be seen from Figure 12 along with Table 11 that, the load carrying capacity of beams strengthened with CFRP is higher than that of strengthened with GFRP, and AFRP, while the ultimate deflection of strengthened beams is relatively independent to the FRP materials.

Table 11. Parametric results of strengthened beams with different FRP materials

Number of FRP Rods	Steel Yielding Moment (kN.m)	Ultimate Bending Moment (kN.m)	Ultimate Deflection (mm)	Ductility Index
CFRP	35.5	53.00	62.98	5.72
GFRP	29.31	40.13	64.51	5.86
AFRP	30.53	47.38	63.37	5.76

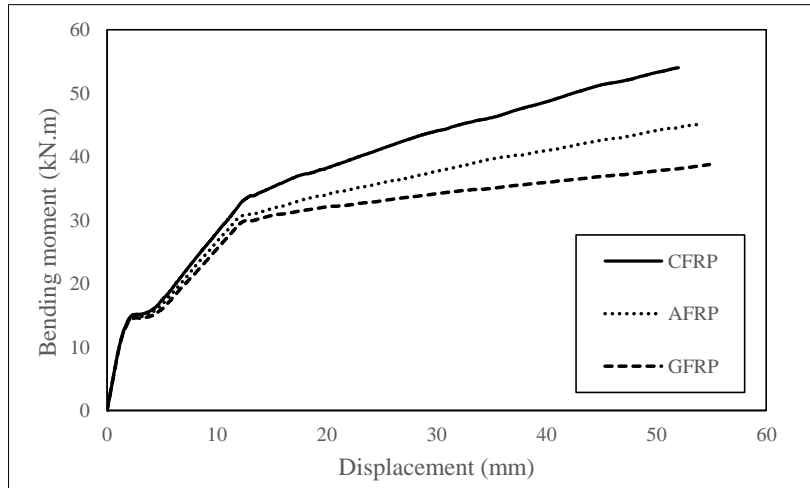

Figure 12. Variation of bending moment mid-span versus displacement for different FRP materials

4.2.4. Effect of Grooves Intervals

Superimposed on Figure 13 and Table 12 are the results of bending moment mid-span deflection of strengthened beams by addressing the effect of groove intervals. The finite element models with cross-section dimension of 200 × 300 mm were used while the other effective factors were chosen as those mentioned before. In these models, two FRP rods with 12 mm diameter and four different groove intervals were considered. It can be seen that the failure bending moment and ultimate deflection slightly vary with groove intervals, i.e., the increasing rate of bending moment is negligible.

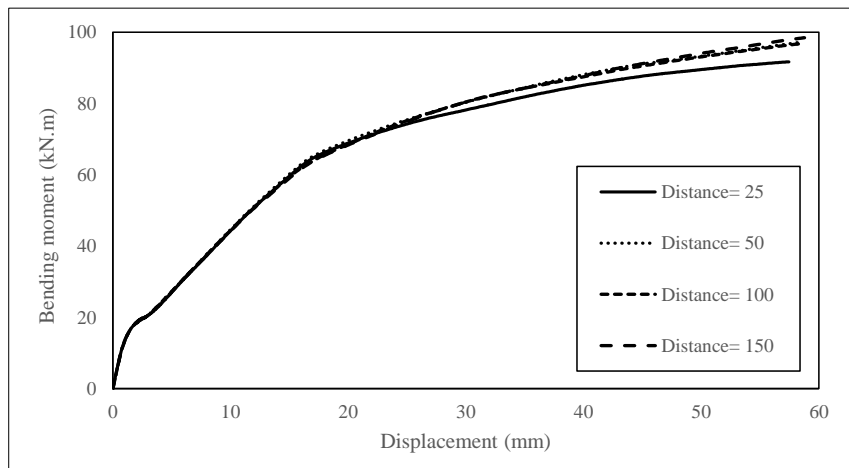

Figure 13. Variation of bending moment mid-span versus displacement for different groove intervals

Table 12. Parametric results of strengthened beams with different groove intervals

Groove Intervals	Steel Yielding Moment (kN.m)	Ultimate Bending Moment (kN.m)	Ultimate Deflection (mm)	Ductility Index
25	64.72	91.70	57.45	3.37
50	65.31	96.13	58.29	3.42
100	63.74	96.06	58.48	3.44
150	64.12	97.46	58.79	3.45

4.3. Bond-Slip Model

The bond-slip relationships between the FRP and filling material and between the filling material and surrounding concrete are described by Equations 1 and 2, respectively.

$$\tau_{\max} (\text{bar-epoxy}) = f_{\text{at}} \mu / G_2 \quad (1)$$

$$\tau_{\max} (\text{epoxy-concrete}) = f_{\text{ct}} \mu / G_1 \quad (2)$$

Where f_{ct} is the concrete tensile strength (MPa), f_{at} is the tensile strength of filling material, μ is the coefficient of friction, which is Equal to 1, and G_1 and G_2 are coefficients that are dependent on the ratios of the groove depth to bar diameter and of the groove width to bar diameter. G_1 and G_2 vary between the range of 0.58 and 1.3 and between 0.5 and 0.72, respectively. Using the finite element calculations, the values of maximum bond shear stress around the NSM FRP rods were obtained and compared with the values of local bond strength in Tables 13 and 14. The results presented in Tables 13 and 14, shows the possibility of slide occurrence between the filling materials and surrounding concrete.

Table 13. Comparison of the results of finite element analysis with the analytical solution for shear bond stresses S-C6 (VC30)

FRP Rod Diameter (mm)	Maximum Shear Stress τ_{13} (MPa)	Maximum Shear Stress τ_{23} (MPa)	Local Bond Strength, epoxy-concrete interface (MPa)	Local Bond Strength, rod- epoxy interface (MPa)
	Finite element analysis		Analytical solution	Analytical solution
6	4.04	0.49	5.86	59
8	5.93	0.69	5.86	59
10	8.57	0.48	5.86	59
12	11.3	0.6	5.86	59
14	13.6	0.89	5.86	59

Table 14. Comparison of the results of finite element analysis with the analytical solution for shear bond stresses S-C6 (VC60)

FRP rod Diameter (mm)	Maximum Shear Stress τ_{13} (MPa)	Maximum Shear Stress τ_{23} (MPa)	Local Bond Strength, epoxy-concrete interface (MPa)	Local Bond Strength, rod- epoxy interface (MPa)
	Finite element analysis		Analytical solution	Analytical solution
6	5.61	0.24	9.31	59
8	6.10	0.35	9.31	59
10	7.38	1.39	9.31	59
12	8.64	1.48	9.31	59
14	11.07	1.52	9.31	59

5. Conclusion

This study aims to investigate flexural strengthening of reinforced concrete beams with near surface mounted FRP bars by finite element software ABAQUS 6.11. Validation of the proposed model was confirmed first by making a comparison with the experimental study presented in the literature. A parametric analysis was also conducted to assess the most effective factors including FRP rods diameter, arrangement, groove intervals and rods materials on the load carrying capacity of existing reinforced concrete beam. The results are presented in the form of tables and design charts for the sake of simplicity to be used by engineers. Following results and conclusions were made through comparison of different graphs.

- The results of finite element analysis of ABAQUS are in good agreement with an experimental study presented in the literature. The consistency of the results confirmed the ability of ABAQUS in simulating strengthening reinforced concrete beam with NSM FRP rods.
- Performance of strengthening reinforced concrete beams with NSM FRP rods was confirmed by comparing the results of strengthening reinforced beams with control beam.
- For the same configuration of strengthened beams, the ultimate load carrying capacity of the strengthened beams increases with an increase in FRP rod diameter. The ductility index of strengthened beams decreases with an increase in FRP rod diameter.
- The results show that the bending moment mid-span deflection response, failure deflection, as well as ductility index, are less affected by different arrangements of FRP rods.

- The beams strengthened with different material types of FRP reinforcement exhibited different performance. The load carrying capacity of beams strengthened with CFRP is higher than that of strengthened with GFRP, and AFRP, while the ultimate deflection of strengthened beams is relatively independent to the FRP materials.
- The results of the ultimate bending moment and ultimate deflection are less affected by different values of groove intervals.
- Comparison of the results of maximum shear stresses with bond shear strength between filling material and concrete, and resin with FRP rods shows that slippage can occur between the filling material and surrounding materials.

6. References

- [1] Sharif, A., Al-Sulaimani, G., Basunbul, I., Baluch, M., and Ghaleb, B., "Strengthening of initially loaded reinforced concrete beams using FRP plates", *ACI Structural Journal*, 91 (2), 160-168, 1994. <https://doi.org/10.14359/4594>.
- [2] Grace, N.F., Sayed, G., Soliman, A., and Saleh, K., "Strengthening reinforced concrete beams using fiber reinforced polymer (FRP) laminates", *ACI Structural Journal-American Concrete Institute*, 96(5), 865-874, 1999. <https://doi.org/10.14359/741>.
- [3] Nordin, H., and Täljsten, B., "Concrete beams strengthened with prestressed near surface mounted CFRP", *Journal of Composites for Construction*, 10(1), 60-68, 2006. [https://doi.org/10.1061/\(asce\)1090-0268\(2006\)10:1\(60\)](https://doi.org/10.1061/(asce)1090-0268(2006)10:1(60)).
- [4] Bakis, C.E., Ganjehlou, A., Kachlakev, D.I., Schupack, M., Balaguru, P., Gee, D.J., Karbhari, V.M., Scott, D.W., Ballinger, C.A., and Gentry, T.R., "Guide for the design and construction of externally bonded FRP systems for strengthening concrete structures", Reported by ACI Committee, 440, 2002.
- [5] Holloway, L.C., and Teng, J.-G., *Strengthening and rehabilitation of civil infra-structures using fibre-reinforced polymer (FRP) composites*, Elsevier, 2008.
- [6] Bilotta, A., Ceroni, F., Barros, J.A., Costa, I., Palmieri, A., Szabó, Z.K., Nigro, E., Matthys, S., Balazs, G.L., and Pecce, M., "Bond of NSM FRP-strengthened concrete: Round robin test initiative", *Journal of Composites for Construction*, 20, 2015. [https://doi.org/10.1061/\(asce\)cc.1943-5614.0000579](https://doi.org/10.1061/(asce)cc.1943-5614.0000579).
- [7] Bilotta, A., Ceroni, F., Nigro, E., and Pecce, M., "Efficiency of CFRP NSM strips and EBR plates for flexural strengthening of RC beams and loading pattern influence", *Composite Structures*, 124, 163-175, 2015. <https://doi.org/10.1016/j.compstruct.2014.12.046>
- [8] De Lorenzis, L., and Teng, J., "Near-surface mounted FRP reinforcement: An emerging technique for strengthening structures", *Composites Part B: Engineering*, 38, 119-143, 2007. <https://doi.org/10.1016/j.compositesb.2006.08.003>
- [9] Bilotta, A., Ceroni, F., Di Ludovico, M., Nigro, E., Pecce, M., and Manfredi, G., "Bond efficiency of EBR and NSM FRP systems for strengthening concrete members", *Journal of Composites for Construction*, 15, 757-772, 2011. [https://doi.org/10.1061/\(asce\)cc.1943-5614.0000204](https://doi.org/10.1061/(asce)cc.1943-5614.0000204).
- [10] Burke, P., "Low and High Temperature Performance of Near Surface Mounted FRP Strengthened Concrete Slabs," Department of Civil Engineering, Queen's University, 2008.
- [11] Sharaky, I.A., Torres, L., Comas, J., and Barris, C., "Flexural response of reinforced concrete (RC) beams strengthened with near surface mounted (NSM) fibre reinforced polymer (FRP) bars", *Composite Structures*, 109, 8-22, 2014. <https://doi.org/10.1016/j.compstruct.2013.10.051>.
- [12] Nguyen, D.M., Chan, T.K., and Cheong, H.K., "Brittle failure and bond development length of CFRP-concrete beams", *Journal of Composites for Construction*, 5, 12-17, 2001. [https://doi.org/10.1061/\(asce\)1090-0268\(2001\)5:1\(12\)](https://doi.org/10.1061/(asce)1090-0268(2001)5:1(12)).
- [13] Novidis, D., Pantazopoulou, S., and Tentolouris, E., "Experimental study of bond of NSM-FRP reinforcement", *Construction and Building Materials*, 21, 1760-1770, 2007. <https://doi.org/10.1016/j.conbuildmat.2006.05.054>.
- [14] Al-Mahmoud, F., Castel, A., François, R., and Tourneur, C., "Strengthening of RC members with near-surface mounted CFRP rods", *Composite Structures*, 91, 138-147, 2009. <https://doi.org/10.1016/j.compstruct.2009.04.040>.
- [15] Barros, J.A., and Fortes, A., "Flexural strengthening of concrete beams with CFRP laminates bonded into slits", *Cement and Concrete Composites*, 27, 471-480, 2005. <https://doi.org/10.1016/j.cemconcomp.2004.07.004>.
- [16] Lee, D., Cheng, L., and Yan-Gee Hui, J., "Bond characteristics of various NSM FRP reinforcements in concrete", *Journal of Composites for Construction*, 17, 117-129, 2012. [https://doi.org/10.1061/\(asce\)cc.1943-5614.0000318](https://doi.org/10.1061/(asce)cc.1943-5614.0000318).
- [17] Lu, W., Ling, Z., Geng, Q., Liu, W., Yang, H., and Yue, K., "Study on flexural behaviour of glulam beams reinforced by Near Surface Mounted (NSM) CFRP laminates", *Construction and Building Materials*, 91, 23-31, 2015. <https://doi.org/10.1016/j.conbuildmat.2015.04.050>.
- [18] Rizzo, A., and De Lorenzis, L., "Behavior and capacity of RC beams strengthened in shear with NSM FRP reinforcement", *Construction and Building Materials*, 23, 1555-1567, 2009. <https://doi.org/10.1016/j.conbuildmat.2007.08.014>.
- [19] Sharaky, I.A., Torres, L., Baena, M., and Vilanova, I., "Effect of different material and construction details on the bond behaviour of NSM FRP bars in concrete", *Construction and Building Materials*, 38, 890-902, 2013. <https://doi.org/10.1016/j.conbuildmat.2012.09.015>.

- [20] Sharaky, I.A., Torres, L., and Sallam, H., "Experimental and analytical investigation into the flexural performance of RC beams with partially and fully bonded NSM FRP bars/strips", *Composite Structures*, 122, 113-126, 2015. <https://doi.org/10.1016/j.compstruct.2014.11.057>.
- [21] Sharaky, I.A., Torres, L., Baena, M., and Miàs, C., "An experimental study of different factors affecting the bond of NSM FRP bars in concrete", *Composite Structures*, 99, 350-365, 2013. <https://doi.org/10.1016/j.compstruct.2012.12.014>.
- [22] Tang, W., Balendran, R., Nadeem, A., and Leung, H., "Flexural strengthening of reinforced lightweight polystyrene aggregate concrete beams with near-surface mounted GFRP bars", *Building and environment*, 41, 1381-1393, 2006. <https://doi.org/10.1016/j.buildenv.2005.05.029>.
- [23] Wang, B., Teng, J.-G., De Lorenzis, L., Zhou, L.-M., Ou, J., Jin, W., and Lau, K., "Strain monitoring of RC members strengthened with smart NSM FRP bars", *Construction and Building Materials*, 23, 1698-1711, 2009. <https://doi.org/10.1016/j.conbuildmat.2008.07.027>.
- [24] Wu, G., Dong, Z.-Q., Wu, Z.-S., and Zhang, L.-W., "Performance and parametric analysis of flexural strengthening for RC beams with NSM-CFRP bars", *Journal of Composites for Construction*, 18, 04013051, 2013. <https://doi.org/10.24200/sci.2017.4207>.
- [25] Bianco, V., Barros, J.A., and Monti, G., "Bond model of NSM-FRP strips in the context of the shear strengthening of RC beams", *Journal of Structural Engineering*, 135, 619-631, 2009. https://doi.org/10.1007/978-3-642-17487-2_173.
- [26] Bianco, V., Monti, G., and Barros, J.A., "Design formula to evaluate the NSM FRP strips shear strength contribution to a RC beam", *Composites Part B: Engineering*, 56, 960-971, 2014. <https://doi.org/10.1016/j.compositesb.2013.09.001>.
- [27] Coelho, M.R., Sena-Cruz, J.M., and Neves, L.A., "A review on the bond behavior of FRP NSM systems in concrete", *Construction and Building Materials*, 93, 1157-1169, 2015. <https://doi.org/10.1016/j.conbuildmat.2015.05.010>.
- [28] Hawileh, R.A., "Nonlinear finite element modeling of RC beams strengthened with NSM FRP rods", *Construction and Building Materials*, 27, 461-471, 2012. <https://doi.org/10.1016/j.conbuildmat.2011.07.018>.
- [29] Kara, I.F., Ashour, A.F., and Köroğlu, M.A., "Flexural behavior of hybrid FRP/steel reinforced concrete beams", *Composite Structures*, 129, 111-121, 2015. <https://doi.org/10.1016/j.compstruct.2015.03.073>.
- [30] Kaveh, A., Bakhshpoori, T., and Hamze-Ziabari, S., "New model derivation for the bond behavior of NSM FRP systems in concrete", *Iranian Journal of Science and Technology, Transactions of Civil Engineering*, 41, 249-262, 2017. <https://doi.org/10.1007/s40996-017-0058-z>.
- [31] Seo, S.-Y., Lee, M.S., and Feo, L., "Flexural analysis of RC beam strengthened by partially de-bonded NSM FRP strip", *Composites Part B: Engineering*, 101, 21-30, 2016. <https://doi.org/10.1016/j.compositesb.2016.06.056>.
- [32] Teng, J.G., Zhang, S.S., Dai, J., and Chen, J., "Three-dimensional meso-scale finite element modeling of bonded joints between a near-surface mounted FRP strip and concrete", *Computers & structures*, 117, 105-117, 2013. <https://doi.org/10.1016/j.compstruc.2012.12.002>.
- [33] Zhang, S.S., and Teng, J.G., "Finite element analysis of end cover separation in RC beams strengthened in flexure with FRP", *Engineering structures*, 75, 550-560, 2014. <https://doi.org/10.1016/j.engstruct.2014.06.031>.
- [34] Simulia, D.S., "Abaqus/CAE user's manual", Providence, RI, Vol., 2007.