

Medical Applications of Space Light-Emitting Diode Technology — Space Station and Beyond

Harry T. Whelan, M.D.^{1a}, John M. Houle, B.S.^{1a},
Deborah L. Donohoe, A.S.,L.A.T.G.^{1a}, Dawn M. Bajic, B.S.^{1a},
Meic H. Schmidt, M.D.^{1c}, Kenneth W. Reichert, M.D.^{1c},
George T. Weyenberg, R.N.^{1a}, David L. Larson, M.D.^{1b}, Glenn A. Meyer, M.D.^{1a}
James A. Caviness, M.D.²

^{1a}*Departments ofNeurology,* ^{1b}*Plastic Surgety and* ^{1c}*Neurosurgery,*
Medical College of Wisconsin, Milwaukee, WI 53226, (414) 456-4090
²*Naval Hospital Great Lakes, Great Lakes, IL 60088, (847) 688-7406*

Abstract. Space light-emitting diode (LED) technology has provided medicine with a new tool capable of delivering light deep into tissues of the body, at wavelengths which are biologically optimal for cancer treatment and wound healing. This LED technology has already flown on Space Shuttle missions, and shows promise for wound healing applications of benefit to Space Station astronauts.

PHOTODYNAMIC THERAPY

Photodynamic therapy (PDT) is a cancer treatment modality that recently has been applied as adjuvant therapy for brain tumors. PDT consists of intravenously injecting a photosensitizer, which preferentially accumulates in tumor cells, into a patient and then activating the photosensitizer with a light source. This results in free radical generation followed by cell death. The development of more effective light sources for PDT of brain tumors has been facilitated by applications of space light-emitting diode array technology; thus permitting deeper tumor penetration of light and use of better photosensitizers. Lutetium Texaphyrin (Lutex) is a new, second generation photosensitizer that can potentially improve PDT for brain tumors. Lutex has a major absorption peak at 730 nm, which gives it two distinct advantages. First, longer wavelengths of light penetrate brain tissue easily so that larger tumors could be treated, and second, the major absorption peak means that more of the drug is activated upon exposure to light. Tumoricidal effects of Lutex have been studied *in vitro* using canine glioma and human glioblastoma cell cultures. Using light emitting diodes (LED) with a peak emission of 728 nm as a light source, a greater than 50 percent cell kill was measured in both cell lines by tumor DNA synthesis reduction. The effectiveness of Lutex against tumor cells *in vitro* thus established, we have taken the first step toward determining its effectiveness *in vivo* by performing experiments to determine the largest dose of both Lutex and light that can be administered to dogs before toxicity is seen *i.e.* the maximum tolerated dose (MTD). Using this dose allows us to effect maximum tumor cell destruction during *in vivo* studies. Based upon the MTD of Lutex in dogs, human trials are now anticipated.

WOUND HEALING

Wounds heal less effectively in space than here on earth. Improved wound healing may have multiple applications which benefiting civilian medical care, military situations and long-term space flight. Laser light and hyperbaric oxygen have been widely acclaimed to speed wound healing in ischemic, hypoxic wounds. Lasers provide low energy stimulation of tissues which results in increased cellular activity during wound healing. Some of these activities include increased fibroblast proliferation, growth factor synthesis, collagen production and angiogenesis. Hyperbaric oxygen therapy has also been shown to beneficially affect these processes.

CP458, *Space Technology and Applications International Forum— 1999*

edited by Mohamed S. El-Genk

© 1999 The American Institute of Physics 1-56396-846-0/99/\$15.00

Lasers, however, have some inherent characteristics which make their use in a clinical setting problematic, including limitations in wavelength capabilities and beam width. The combined wavelengths of light optimal for wound healing cannot be efficiently produced, and the size of wounds which may be treated by lasers is limited. Light-emitting diodes (LEDs) offer an effective alternative to lasers (Table 1, Figure 1). These diodes can be made to produce multiple wavelengths, and can be arranged in large, flat arrays allowing treatment of large wounds.

Our experiments suggest potential for using LED light therapy at 680, 730, and 880 nm simultaneously, plus hyperbaric oxygen therapy, both alone and in combination, to accelerate the healing process in Space Station missions, where prolonged exposure to microgravity may otherwise retard healing.

TABLE 1. Output Specifications for Wound Treatment LED Array.

	Min	Typ	Max
Surface Energy (670nm)			
Power Output (mW/cm ²)	25	29	34
Quantum (umol M ⁻² S ⁻¹)	1800	2100	2400
Surface Energy (735nm)			
Power Output (mW/cm ²)	25	29	34

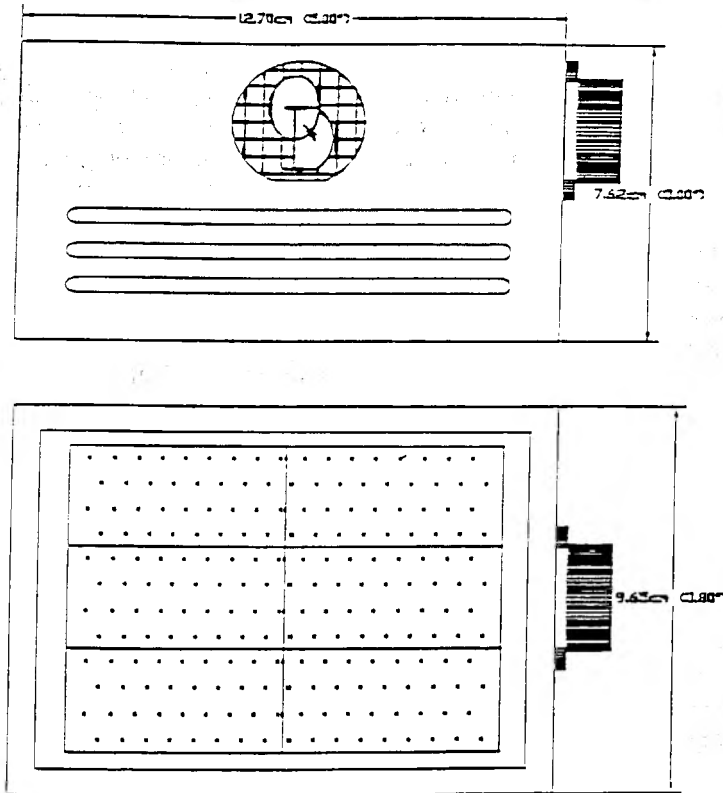

FIGURE 1. LED Array for Treating Wounds at 670 nm and 735 nm.

PART I - PHOTODYNAMIC THERAPY

Introduction

Photosensitizers are light sensitive molecules that upon activation with light can cause photodynamic damage to cells in which they localize (Henderson, 1992). For photodynamic therapy of solid tumors, in particular brain tumors a photosensitizer should selectively localize in malignant cells versus normal brain and be activated by light that can penetrate deeply into solid tissue. In general, light penetration in the brain and other solid tissues increases for light with longer wavelengths (Eggert, 1993). Therefore, in order to effectively treat solid tumors one must have a photosensitizer that absorbs light preferentially at long wavelengths.

Traditionally two similar photosensitizers, namely Hematoporphyrin and its more purified form Photofrin® have been the most widely applied in the adjuvant treatment of brain tumors (Kostron, 1996; Muller, 1995; Origitano, 1994; Popovic, 1995). Both of these photosensitizers have major absorption peaks in the short wavelengths of light and a smaller peak in the near infrared spectrum at 630 nm. At that wavelength, light penetration is limited and deeper photosensitized tumor cells are not eliminated because of the lack of light activation (Kostron, 1996). Therefore, one way to improve the efficacy of PDT of solid tumors is to use photosensitizers that can absorb at longer wavelengths of light.

Red laser light is frequently produced using an argon ion or KTP/YAG laser beam that is converted by a dye module, usually to 630 nm. For longer wavelengths of light improved technology is required. Laser conversion to near-infrared wavelengths is inherently costly and inefficient, but allows for light to be delivered by fiberoptics. For non-fiberoptic delivery of light, other light sources could be a useful alternative.

Light-emitting diodes (LED) are one such light source that may prove to be an effective alternative to lasers for PDT. LED's have been frequently used to emit low power, broad spectrum light of 25-30 nm bandwidths for photosynthesis research in plants. LED lamps traditionally consist of an array of semiconducting LED chips. In recent years, improvements in semiconductor technology have substantially increased the light output of LED chips. A novel type of LED chip is based on the semiconductor Aluminum Gallium Arsenide (AlGaAs). These LED chips can be manufactured to emit light with a peak wavelength between 630 nm and 940 nm. This range of wavelengths overlaps with the absorption spectrum of photosensitizers used for PDT of brain tumors.

Lutetium Texaphyrin (Lu-Tex) is a new photosensitizer that has strong light absorption from 730 to 770 nm with absorption peak at 732 nm (Young, 1996). In addition, Lu-Tex is water-soluble and has a high, long-lived quantum yield for triplet states that can produce cytotoxic singlet oxygen.

The aim of this study was to evaluate the potential effects of Lu-Tex in combination with light-emitting diode balloon applicator on normal brain tissue and to investigate cytotoxicity in glioma cell lines.

Materials and Methods

In vitro and in vivo experiments were conducted to document tumor-cell kill and neurologic safety in the delicate brainstem region (the posterior fossa) using PDT with LED-light and Lu-tex.

Lu-Tex In Vitro Experiments

Red light for PDT in vitro was produced by a Q-beam photosynthesis lamp (Figure 2) (Quantum Devices, Inc, Barneveld, WI, USA). The emitting surface measured 6x10 cm and contained 198 light emitting diodes. The LED chips are on the surface of a ceramic sink with a ventilator to prevent overheating. In order to deliver LED light *in vivo*, an LED probe was constructed (Figure 2). The LED probe consists of a 10 cm hollow steel tube that has at its tip the LED chips arranged in a cylinder. The core of the tube contains three channels. One channel contains insulated wires

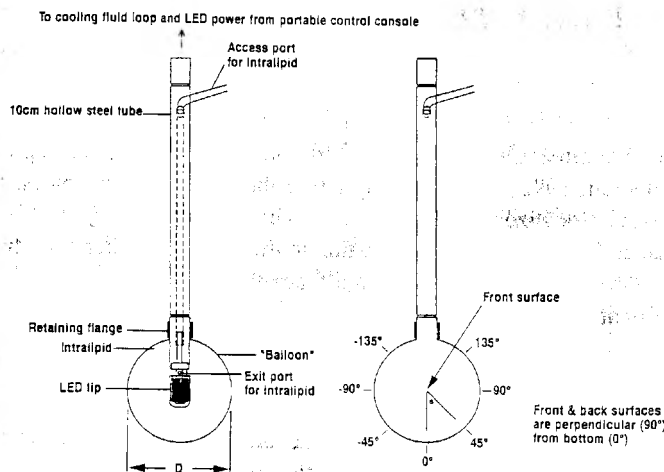

FIGURE 2. The LED Balloon Applicator in a Schematic Overview.

which provide electricity for the LED tip. A second channel contains sterile water which acts as a cooling fluid when circulated around the tip. The third channel provides access for the 0.1 percent intralipid fluid used to inflate the balloon at the tip of the probe. The pump for the cooling fluid and the power supply are in a portable base unit. Power output of the LED tip is adjusted via a potentiometer on the base unit which controls current flow. The temperature of the tip was continuously monitored and was not allowed to exceed 35°C at any time during the experiment. The balloon of the LED probe was inflated with a 0.1 percent intralipid solution. Balloon diameter ranged from 2 cm to 5 cm. The tip of the LED probe was placed in the center of the balloon. In this configuration, the balloon is known to scatter light uniformly, with light irradiation varying by no more than twenty percent of the average when measured at any point on the balloon's surface. The total power output was 1.0 watt at the tip and was kept constant.

All glioma cell lines were grown in monolayer tissue culture in P100 tissue culture dishes at 37 °C in a humidified 5 to 10 % CO₂ atmosphere, as previously described. Cultures were harvested by gently dislodging the cells from their substratum with a Pasteur pipette for in vitro assay. Glioma cells were then plated in 1.6 cm wells of a 24 plate. Following 24 hours of attachment Lu-Tex was added in increasing concentrations from 0.0 to 30 μM. All experiments were done in triplets. Control cells received an equal volume but no Lu-Tex. The Lu-Tex concentration used did not cause any dark toxicity. After 3 hours incubation in the dark the cells were exposed to the light from the LED lamp. The energy density was 1.8 J/cm². Approximately 24 hours after completion of LED treatment cell viability was assessed by measuring uptake for 3H-thymidine in DNA. After extraction the radioactivity was counted.

Lu-Tex in Vivo Experiments

Adult mongrel dogs weighing approximately 20 kg were used for in vivo PDT. All animals were incubated and placed under general anesthesia. A wide posterior fossa craniectomy was performed. A Y-shaped dural incision was extended to expose the cerebellum, lower brainstem and upper cervical spinal cord (Schmidt, 1994; Schmidt, 1996; Whelan, 1993). The LED balloon applicator with a diameter of 2 cm was placed into the posterior fossa on the brainstem. All canines received Lu-Tex 3 to 5 hours prior to light exposure (except light only controls) in increasing doses starting a 0.75 mg/kg according to the Fibonacci dose escalation scale (Collins, 1986; Goldsmith, 1975). The maximum tolerated dose (MTD) was defined as the dose given to the group of canines that preceded the group with 50% neuro toxicity. The LED was adjusted to deliver light spectrum with a peak wavelength of 732 nm and bandwidth of 25 nm. The structural details of the probe and spectral analysis were published previously (Schmidt, 1996).

LED and Lu-Tex
2.0 mW/cm², 1.8 J/cm²
Canine Glioma (2A9)

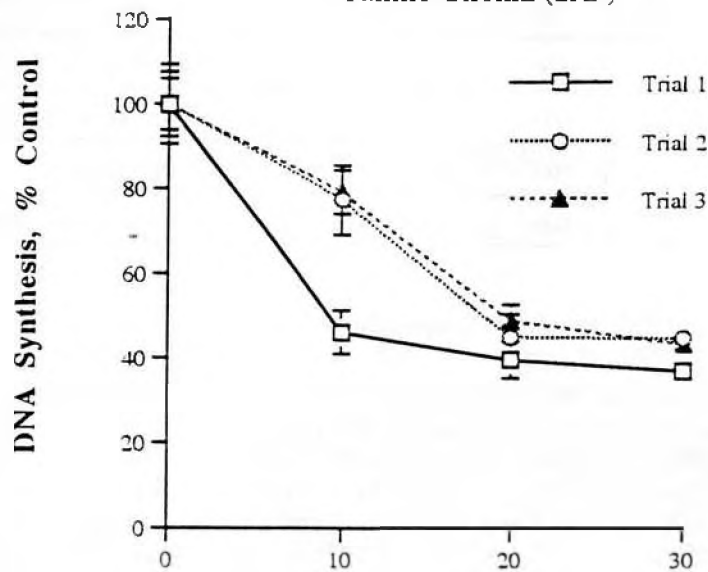

FIGURE 3. Lu-Tex Dose (uM) 24 hr. Incubation.

Results

Photodynamic therapy (PDT) results in vitro demonstrate that LED light produces a photodynamic effect using Lutex which results in brain tumor cell killing. PDT results in vivo further demonstrate that LED light at 100 J/cm² is safe with a maximum tolerable dose (MTD) of Lutex of 1.6 mg/kg for treatment in the delicate brainstem regions.

Photodynamic Therapy for Glioma Cells in Vitro

The graph in Figure 3 shows that Lu-Tex sensitized glioma cells are significantly inhibited when exposed to LED light. Light only and Lu-Tex only controls demonstrated no significant growth inhibition on glioma cells (Figure 3).

Photodynamic Therapy in Canine Model

Table 2 summarizes the results of the canine neurotoxicity study. Light doses for up to 150 J/cm² had no effect on normal brain tissue if the canines did not receive any Lu-Tex. Several animals in the Lu-Tex escalation study experienced mild post operative ataxia that resolved within 48 hours. One animal died 48 hours after PDT with 1.0 mg/kg and 100J/cm² light. Autopsy revealed a large extradural blood clot compressing the brainstem that was most likely traumatic. Other animals at the same dose showed no permanent deficits. The Lu-Tex dose was then escalated progressively at a constant light dose of 100 J/cm². At 2.0 mg/kg Lu-Tex, all animals expired immediately after PDT (< 24 h) secondary to respiratory difficulties. In addition, they showed severe signs of quadraparesis, ataxia and swallowing difficulties. The dose was then decreased to 1.6 mg/kg. All animals experienced mild transient ataxia except for one canine which expired 48 hours after surgery. Autopsy revealed a normal brain structure unlike the animals at 2.0 mg/kg. We subsequently repeated the same dose of Lu-Tex and Light. These additional four canines had no permanent deficits. Thus, the MTD according to our protocol is 1.6 mg/kg and 100 J/cm² (Table 2).

TABLE 2. Summary of Canine Photodynamic Therapy Study.

Lu-TeX Dose (mg/kg)	Canine N=21	Light Dose (J/cm ²)	Clinical Toxicity	Autopsy
0.5 to 075	6	< 150	none	normal
1.00 to 1.25	6	100	1 mortality	Cerebellar hemorrhage
1.6	6	100	1 mortality	Normal brain
2.0	3	100	3 mortalities	Severe brainstem edema

Discussion

Lutetium texaphyrin (Lu-TeX) is a pure, hydrophilic photosensitizer that is synthesized by inserting a lutetium metal into the center of ring shaped, planar porphyrin molecule called texaphyrin. The mechanism by which porphyrins including texaphyrins preferentially accumulate in cancer cells is not fully elucidated. Tumor localizing properties of texaphyrins are related to high metabolism in cancer cells similar to other porphyrins. Texaphyrins can be engineered with different central metals which influences the biochemical reaction they mediate while retaining their tumor localizing properties. Gadolinium texaphyrin has been evaluated as a MRI contrast agent, radiationsensitizer and chemosensitizer while Lutetium texaphyrin has been developed as a photosensitizer (Kostenich, 1997; Woodburn, 1998; Woodburn, 1996; Young, 1996; Young, 1994; Young, 1996). Lu-TeX exhibits strong light absorption in the far red spectrum (730 to 770 nm, peak 732 nm) where tissue light penetration is at least doubled compared to 630 nm (Eggert, 1994).

The therapeutic efficacy for PDT of brain tumors has been demonstrated in several clinical and experimental studies (Kaye, 1988; Kaye, 1987; Muller, 1987; Muller, 1990; Muller, 1995; Muller, 1996). Most series for human recurrent gliomas use Photofrin or HP and 630 nm laser light, which has demonstrated a tumor response to treatment. Despite that success, local recurrence remains the most common cause of treatment failure after PDT just like after conventional treatment (Kostron, 1996). Most investigators think that this is most likely secondary to infiltrative tumor cell in the brain adjacent to tumor (BAT) (Powers, 1991). Studies have shown that photosensitizer is taken up in the BAT and that increasing the light dose which increases tissue light fluence demonstrates a greater therapeutic success (Hill, 1990; Muller, 1995). Another way to increase the light dose for deeper tissues is to increase the wavelength of the incident light into the far red spectrum. Unfortunately, Photofrin and HP absorb light poorly beyond 630 nm. New photosensitizers like BPD and Lu-TeX absorb light at longer wavelength (Aveline, 1994; Young, 1996).

Normal brain tissue toxicity can occur in PDT of brain tumors. Several studies indicate that at high photosensitizer dose Photofrin, hematoporphyrin, and even second generation photosensitizers like Benzoporphyrin derivative, can sensitize normal brain tissue to photodynamic effect (Muller, 1987; Schmidt, 1994; Schmidt, 1996; Whelan, 1993). This study indicates that Lu-TeX can cause normal brain tissue damage at high doses (>2.0 mg/kg). With careful drug and light dosimetry this effect can be limited. At the MTD of 1.6 mg/kg the canine brainstem tolerated PDT effects. In previous studies using the same posterior fossa canine model we demonstrated that normal tissue toxicity is related to high photosensitizer doses rather than high light doses.

In addition to limited normal tissue toxicity, Lu-TeX also demonstrated the ability to inhibit the growth of glioma cells in vitro similar to other porphyrin based photosensitizers. Lu-TeX has been shown to be localized to metastatic brain tumors in humans. Thus, Lu-tex with LED light have the potential to effectively treat brain tumors.

CONCLUSION

Lu-Tex combined with an LED light source can potentially increase the therapeutic efficacy of PDT of brain tumors without increasing normal tissue toxicity. Longer wavelengths of light than previously practical were provided by LED technology. The development by NASA of new light sources and light delivery devices is of critical importance for improving photodynamic therapy.

PART II - WOUND HEALING

Improved wound healing may have multiple applications which may benefit civilian medical care, military situations and long-term space flight.

In space, wounds may heal differently than here on earth. Laser light has shown some benefit for wound healing but has limited surface area and wave length. Light-emitting diodes, developed by NASA, offer the potential for dramatic improvement in wound healing over lasers for future space flight, civilian and military applications.

Laser light and hyperbaric oxygen have been widely acclaimed to speed wound healing in ischemic, hypoxic wounds. There have been few comparative studies done to document value over other methods such as meticulous surgical debridement, antibiotics, limited amputation, contact casting, adjunctive pentoxifyline, topical oxygen, topical growth factors, and careful attention to host factors such as diabetes control, nutrition, etc.

Light Studies

A category of lasers termed "soft" or "cold" lasers, provide low energy stimulation of tissues which may result in increased cellular activity during wound healing (Miller, 1993). This principal of laser biostimulation was introduced by the Russian's over twenty years ago and is applied primarily in dermatology for skin wound healing. It has also been suggested that biostimulation by light may be useful in other wound healing scenarios. Low-powered lasers were used to treat areas of skin and accelerate wound healing. Subsequently, cold lasers have been used to provide pain relief and perform non-surgical face lifts. In eastern europe, helium neon-lasers with low power densities, were reported to stimulate skin graft healing in rabbits, regenerate burned skin in rats, and accelerate mucous membrane repair in the tongue in mice.

The proposed mechanism of action of low-powered light irradiation was supposed to effect cellular metabolic processes and improve regeneration potential (Gamaleya, 1977). There have been many problems trying to determine what wave-lengths of light are best. The use of lasers has been problematic because of limited wave-length and beam physics (narrow beam of coherent light). Studies have included different kinds of lasers, wave-lengths, time-exposures, energy settings, laboratory animals and cell types (Meyers, 1990).

Wound healing has three phases. First a substrate is laid down, then cells proliferate, then there is remodeling of tissue. The data published so far suggests that laser biostimulation produces its primary effect during the cell proliferation phase. It is felt that mitochondria are receptive to monochromic light and that these laser experiments have increased respiratory metabolism of certain cells (Meyers, 1990). Such things as fibroblast proliferation, collagen synthesis, growth factor production, including keratinocyte growth factor (KGF), transforming growth factor (TGF) and platelet-derived growth factor (PDGF), as well as macrophage stimulation, and greater rate of extracellular matrix production have been reported.

Lasers produce unique light irradiation differing from other light sources, but are limited in wavelength capabilities and beam width for technical reasons. Previous experiments, however, using lasers have demonstrated unique properties in biological systems. Scientists experimenting with low intensity laser's attempting to evaluate effects on tissues and cell cultures have published articles about stimulating cell activity. Wavelengths have typically varied from 630 - 730 nm but have been as high as 780 nm. Four Joules/cm² of total light dose, with powers in the milliwatt range have

typically been provided. Fibroblast proliferation, attachment and synthesis of collagen and procollagen have all been produced.

It was reported in earlier literature that helium neon laser light at 633 nm was optimal for wound healing (Basford, 1986) using 1 mW exposures and greater to provide 4 Joules/cm² energy density. Later studies looking at in vitro skin fibroblast stimulation demonstrated that consecutive exposures of 660 nm and 780 nm laser light at 24 hour intervals increased collagen production fourfold compared with untreated cultures (Lubart, 1992, 1997; Yu, 1997). Beauvoit (1994, 1995) demonstrated that mitochondria provide 50% of the tissue absorption coefficient and 100% of the light scattering at 780 nm due to cytochrome aa₃, cytochrome oxidase and other mitochondrials chromophores. Fibroblasts irradiated at 660 nm with 2.16 J/cm² increased fibroblast growth factor synthesis and fibroblast proliferation (Yu, 1997). Concurrent DNA synthesis measurements confirmed this (Mester, 1973; Abergel, 1984). Karu (1989) demonstrated increased DNA synthesis by irradiation at 680 nm, increased protein synthesis at 750 nm, and increased cell proliferation at 890 nm, which was 10 times more effective than other near-infrared wavelengths, requiring only 1 J/cm². Laser stimulation of collagen synthesis measured by incorporation of radioactive amino acids was demonstrated at 693 nm with similar results. More recently, the work of Dr. Norman Salansky⁴⁴ has indicated that growth factor production and collagen synthesis may be improved at wavelengths of 660 - 680 nm and stimulation of new small blood vessel growth was produced at 880 nm wavelength. Such studies have been limited by the constraints of laser technology, but LED's offer improved power and area of distribution at longer wavelengths.

The mechanism of action is not fully understood, but possible explanations include stimulation of ascorbic acid uptake by cells, stimulation of photo receptors in the mitochondria respiratory chain, changes in cellular ATP or cAMP levels and cell membrane stabilization.

Animal studies in rats, mice, guinea pigs, and swine have been performed. Human studies have also occurred involving greater amounts of epithelialization for wound closure (Mccaughan, 1985). A number of other human studies have demonstrated that low energy laser systems promote tissue healing (Lyons, 1987; Kana, 1981; Mester, 1982; Kovacs, 1982; Abergel, 1987; Cummings, 1985; Hunter, 1984; Karu, 1989; Braverman, 1989; Kovacs, 1974; Haini, 1982; Mester, 1985; Kahn, 1984; Chlebarov, 1988; Sugue, 1990). Other studies have demonstrated difficulties with human healing using laser systems. Wavelength and waveform of the optical source, power, output and three dimensional energy density of the system as well as the duration of individual treatments and treatment schedules, all limited by laser technology, would be improved with LED technology (Hunter, 1984; Surinchak, 1983; Basford, 1986; Brunner, 1986; Lundeberg, 1991; Santoianni, 1984; Gogia, 1992; Kana, 1982; Van Breugel, 1992; Braverman, 1989; Mester, 1985; Kroetlinger, 1980; Longo, 1987). In a study of nine patients with 12 leg ulcers, the combination of two light sources of 660 nm and 880 nm wavelengths, each having a power of 6 mW and energy density of 4 Joules/cm² produced differences of 16.3 mm²/week (p=0.34) between placebo (1.3±4.7 mm²/week) and light-treated (17.6±6.4 mm²/week) groups, during the first 4 weeks of low energy photon therapy, but the assistance of another treatment modality to maintain the original rate of healing is required.

It is believed that our experimental design will address these issues. We plan to use LED's emitting light at 680 nm, 730 nm, and 880 nm to stimulate growth factor production, collagen synthesis and microvascular angiogenesis in healing wound tissue. Furthermore, LED-treatment will be combined with hyperbaric oxygen and growth factor therapy.

Hyperbaric Studies

Publication of meticulously detailed studies that examine the use of HBO for specific problems have been slow, even though HBO therapy has been in clinical use since 1943. Both the difficulty and cost of developing controlled, double-blind, randomized trials have impeded the scientific standards of medicine today, despite a progression of studies of the diabetic foot. Davis et al believed that appropriate historic controls for demonstrating the efficacy of hyperbaric therapy could be represented by patients with chronic wounds that were unresponsive to standard techniques (Davis, 1988). No prospective controlled trial has been used for the surgical technique for management of the diabetic foot problem (Davis, 1988; Davis, 1991; Cianci, 1993). And as stated by Feldmeier et al no double-blind studies exist in the entire field of radiation therapy (Feldmeier, 1996). Such studies are impossible for ethical and technical reasons.

The necessity and expense of performing double-blind hyperbaric studies has long been recognized. Two commonly used study endpoints in hyperbaric studies are the outcome based reduction of amputation rates, and "healing", defined as the lack of need for amputation above the ankle. Existing studies do not include an absolute measure of healing such as measurement of granulation tissue.

The medical practice paradox that compensates for limb amputation rather than limb salvage is frequently described by Cianci (1988) and Cianci (1994). The management of chronic wounds, especially in an aging society, is a growing problem that calls for novel techniques based on the wound microenvironment. Two approaches that specifically address the identified pathophysiologic processes are hyperbaric oxygen therapy and growth factor research. Hyperbaric oxygen therapy, however, is the most specific treatment for the identified abnormality.

Davies (1987) described a retrospective review of the group's experience. Their findings demonstrated a 70% success rate of healing and a 30% failure. Patients who did not require amputation above the ankle were classified as successful. Patients with large vessel disease were often categorized as failures due to their limitations of distal perfusion.

In addition, several other retrospective articles have been published (Hart, 1979; Pedesini, 1984; Perrins, 1986; Oriani, 1992) but the data reported by Stone (1995) and Stone and Scott (1995) is the most provocative. Stone et al found that patients who were referred for hyperbaric therapy showed more wounds per patient, greater wound volumes, and had a greater percentage recommended for amputation. Even though the wounds were more serious, the limb-salvage rate was greater in the hyperbaric treated group (72% versus 53%; $p < 0.002$).

The data collected by Stone and Scott measured wound volumes by categorizing patients into three groups: standard care, standard care with adjuvant hyperbaric therapy, and both combined with growth factors. Standard care (60% healing) versus standard care with hyperbaric therapy (63% healing) showed no significant difference in healing rates. However, the average wound volume in the hyperbaric-treated group (2,750 mm³; n=38) was twice the size of the standard care group (1,144 mm³; n=250). The greatest healing rate was demonstrated by the group that was treated with the combination of standard care, hyperbaric therapy, and growth factors (80%; 2,414 mm³; n=49). Like animal studies this data suggests a synergistic effect of combination therapy. Thus, we will combine LED near infrared light, hyperbaric oxygen, and growth factors in our human treatment protocol.

Methods

Fibroblast Studies:

DNA synthesis in cultured 3T3 fibroblasts was measured after incubation in the presence and absence of 4 J/cm² of LED light at 680 nm, 730 nm and 880 nm using tritiated (3H) thymidine incorporation. After 3-4 hours in 0.01 mCi/ml (methyl 3H) thymidine (6.7 uCi/mole), cells were washed and assay stopped with 10% trichloroacetic acid. Cells were dissolved with 0.2N sodium hydroxide, and tritium uptake counted in liquid scintillant using a scintillation counter.

Animal Studies:

- 44 male Sprague-Dawley rats were wounded with a 35 mm full-thickness skin excision.
- Rats were divided into four groups which were treated as follows:
 - Group 1-Controls, no treatment
 - Group 2-Experimental light treatment (ELT) only
 - Group 3-Hyperbaric oxygen treatment (HBOT) only
 - Group 4-ELT and HBOT
- ELT consisted of seventeen daily exposures to 4 Joules/cm² each of 680 and 730 nm light.
- HBOT consisted of seventeen daily exposures to 2.4 atmospheres of pure oxygen for 90 minutes.
- Wounds size was monitored by photography and analyzed by SigmaScan Pro software.
- Wound area was expressed as a percentage of original size; groups compared to by Student's T-test.

Results

Our in vivo wound healing experiments demonstrated a therapeutic benefit of LED light plus hyperbaric oxygen therapy (HBOT), especially in speeding the early phase of wound closure. This is particularly significant, since the treatment improved upon healing in a model using wounds in healthy rats.

Animal Studies:

Preliminary data indicate that ELT decreases wound size 7, 12, and 17 days after wounding when used alone and 7 and 12 days after wounding when combined with HBOT (Figure 4) (Table 3).

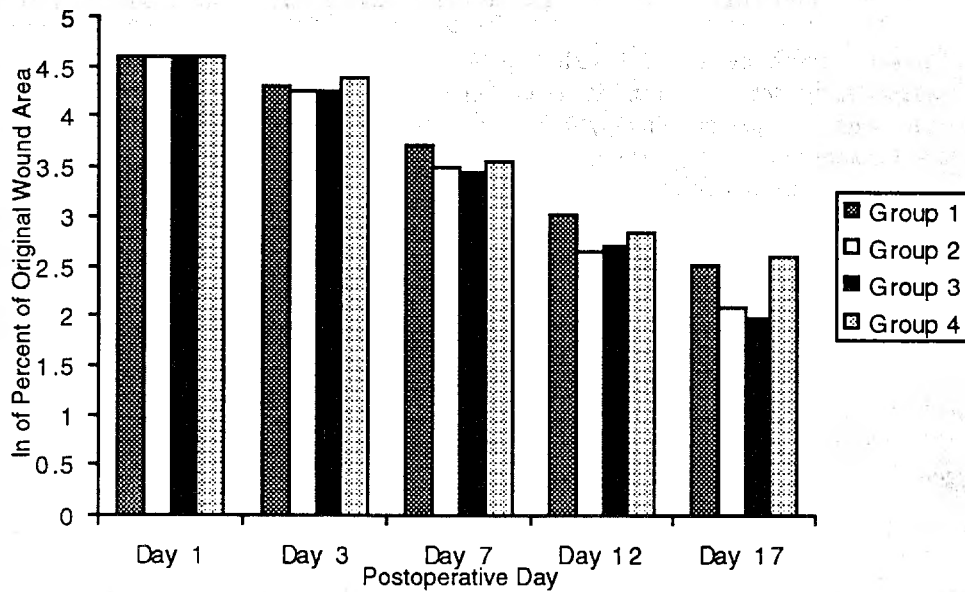

FIGURE 4. Reduction in Wound Size in Experimental Controls and Treated Rats.

TABLE 3. Reduction in Wound Size in Experimental Controls and Treated Rats.

	Wound Area. Percent of Original Sizes				
Group	Day 1	Day 3	Day 7	Day 12	Day 17
Untreated control	100	73.5±7.9	41.4±8.4	20.4±3.8	12.4±2.9
ELT only	100	69.2±5.7	33.2±6.2	14.1±3.7	8.1±2.0
HBOT only	100	70.1±4.5	31.4±3.5	14.8±1.6	7.2±1.6
ELT and HBOT	100	79.9±13.7	34.7±5.5	17.0±4.6	13.4±3.4

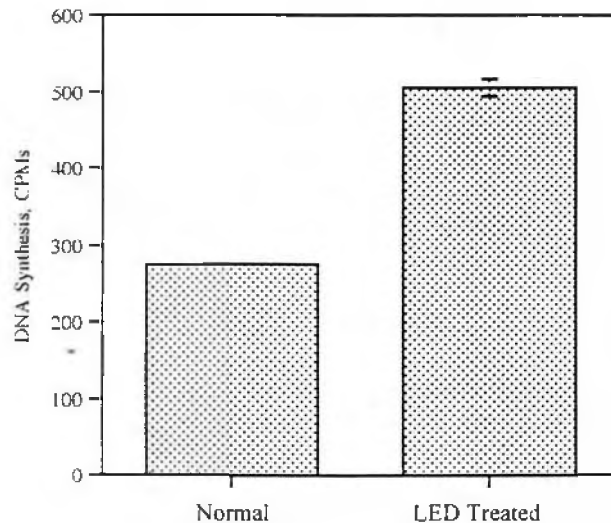

FIGURE 5. Increased DNA Synthesis In Fibroblasts Treated With LED Light Compared With Normal Control Expressed as (3H) Thymidine Uptake In Counts Per Minute

Cultured fibroblast data supports the animal data by demonstrating doubled DNA synthesis when cells were treated with LED light (Figure 5). This is particularly important since fibroblasts are the major cell type needed to grow and divide in healing wounds.

Discussion

As previously noted, prior studies involving lasers have demonstrated that light does help wound healing, but current applications of light therapy are limited to the use of low power laser light. Due to the nature of light physics and engineering constraints of laser design, the range of wavelengths attainable is limited. Due to the coherent beam of light unique to lasers, their ability to easily treat large areas is also limited. NASA's development of light emitting diodes (LED) offers an alternative source for light therapy that can be designed to produce many wavelengths and in an array of varied shape—thus enabling it to direct light over a large or 3-D surface. In this case study, the LEDs were designed to emit light at wavelengths proven, in prior studies of laser light, to speed wound healing. The LED's were manufactured in a square box array to provide uniform energy density to the subject rats.

Cultured fibroblast data demonstrated doubled DNA synthesis in the cell type most proliferative in healing wounds. This provides tremendous encouragement in support of animal studies leading to human trials. Data in rats agrees. The data from this initial group shows that there is a role for LED therapy. The rats receiving LED therapy showed a significant increased wound healing when compared to controls. Additionally, this rate of healing was comparable to the rate resulting from the established daily hyperbaric oxygen treatment (HBOT) of 2.4 ATA for 90 minutes. The current standard of care for problem wounds allows for the adjunctive therapy of HBOT in cases such as diabetic ulcers, graft failures, radiation necrosis, and other ischemic wounds. However, the access of patients to a hyperbaric treatment center is not always available, and many factors can make it difficult for patients to undergo high pressure treatments. Our initial data is promising in that it offers the first evidence to a second adjunctive modality for problem wounds. While the combined treatment of both LED and HBOT did increase wound healing when compared to controls, it did not offer synergistic effects on healing in this initial group. Additional studies with larger groups of rats, as well as the addition of 880 nm LED-light in combination with 680 nm and 730 nm LED's are currently underway, and may offer insight into mechanisms for improving synergy. Future human trials of LED and HBOT efficacy are also planned.

We anticipate that our continued trials will consistently demonstrate the efficacy of LED therapy on wound healing. The ability to make LEDs of various wavelengths, their low power consumption, and ability to design the actual LED array in various shapes and sizes makes it ideal for an adjunctive therapy. It has unique application to military and space environments, where speed of healing, durability, ease of operation, and portability are essential factors. LED excels in these areas, presenting a possible treatment modality that may enable the success of a mission compromised by an injury.

ACKNOWLEDGEMENTS

We wish to thank Karen Zeqiri for assistance in manuscript preparation. The LED arrays were provided by Quantum Devices, Inc., Barneveld, WI. We also gratefully acknowledge the Department of Defense, Air Force Material Command, Armstrong Laboratories, Davis Hyperbaric Laboratory, Brooks Air Force Base, TX for providing the hyperbaric chamber used in this research. This work was supported by NASA-SBIR #NASW-499, National Aeronautics and Space Administration NAS8-97277, Children's Hospital Foundation, the MACC Fund and Quantum Devices, Inc.

REFERENCES

- Abergel, R., Lam, T., Meeker, C., Dwyer, R., Uitto, I., *Clin Res* **32**, 16a (1994).
- Abergel R.P., Lyons R.F., Castel J.C., Dwyer R.M., Uitto J., *J Dermatol Surg Oncol* **13**, 127-133 (1987).
- Aveline B., Hasan T., Redmond R.W., *Photochemistry & Photobiology* **59**(3), 328-35 (1994).
- Basford, J., *Mayo Clin Proc* **61**, 671-675 (1986).
- Basford J., Hallman H.O., Sheffield C.G., Mackey G.L., *Arch Phys Med Rehabil* **67**, 151-154 (1986).
- Beauvoit B., Evans S.M., Jenkins T.W., Miller E.E., Chance B., *Analytical Biochemistry* **226**, 167-174 (1995).
- Beauvoit B., Kitai T., Chance B., *Biophysical Journal* **67**, 2501-2510 (1994).
- Braverman B., McCarthy R.J., Ivankovich A.D., Forde D.E., Overfield M., Bapna M.S., *Lasers in Surg & Med* **9**, 50-58 (1989).
- Brunner R., Haina D., Landthaler M., Waidelich W., Braun-Falco O., *Curr Probl Dermatol* **15**, 111-116 (1986).
- Chlebarov S., *Med Focus* **3**, 48-49 (1988).
- Cianci P., *JAPMA* **84**, 448 (1994).
- Cianci P., Hunt T.O., "Adjunctive Hyperbaric Oxygen Therapy," in *The Treatment of Diabetic Wounds of the Foot*, in *The Diabetic Foot*, edited by M.E. Levin, L.W. O'Neal, J.H. Bowker, St Louis, Mosby Year Book, 1993.
- Cianci P., Petrone G., Drager S.W., et al., *J Hyperb Med* **3**, 127 (1988).
- Collins J.M., Zaharko D.S., Dedrick R.L., Chabner B.A., *Cancer Treatment Reports* **70**(1), 73-80 (1986).
- Davis J.C., "Enhancement of Healing," in *Hyperbaric Oxygen Therapy: A Critical Review*, edited by E.M. Camporesi, A.C. Barker, Bethesda, MD, Undersea and Hyperbaric Medical Society, 1991.
- Davis J.C., Buckley C.J., Bau P., "Compromised Soft Tissue Wounds; Correction of Wound Hypoxia," in *Problem Wounds: The Role of Oxygen*, edited by J.C. Davis, T.O. Hunt, New York, Elsevier Science Publishing, 1988.
- Eggert H.R., Blazek V., *Advances in Experimental Medicine & Biology* **333**, 47-55 (1993).
- Feldmeier J.J., Court W.S., Matos L.A., Undersea Hyperb Med **23**, 10 (1996).
- Gamaleya, N., "Laser Biomedical Research in the USSR" in *Laser Applications in Medicine and Biology*, 3rd Ed, edited by M.L. Wolbarsht, New York, London, Plenum Press, 1977, pp. 114-126.
- Gogia P.P., Marquez R.R., *Osteomy Wound Mgmt* **38**, 38-41 (1992).
- Goldsmith M.A., Slavik M., Carter S.K., *Cancer Research* **35**(5), 1354-64 (1975).
- Haina D., Brunnner R., Landthaler M., et al., *Laser Basic Biomed Res* **22**, 1-3 (1982).
- Hart G.B., Strauss M.C., "Responses of Ischemic Ulcerative Condition to OHP," in *Proceedings of the Sixth International Congress on Hyperbaric Medicine*, edited by G Smith, Aberdeen University Press, Aberdeen, UK, 1979.
- Henderson B.W., Dougherty T.J., *Photochemistry & Photobiology* **55**(1), 145-57 (1992).
- Hill J.S., Kaye A.H., Sawyer W.H., Morstyn G., Megison P.D., Stylli S.S., *Neurosurgery* **26**(2), 248-54 (1990).
- Hunter J., Leonard L., Wilson R., Snider G., Dixon J., *Lasers in Surg & Med* **2**, 285-290 (1984).
- Kahn J., *J Ortho Sports Phys Ther* **3**, 203-204 (1984).
- Kana J.S., Hutschenreiter G., Haina D., Waidelich W., *Arch Surg* **116**, 293-295 (1981).
- Karu T., *Health Physics* **56**, 691-704 (1989).
- Kaye A.H., Morstyn G., Apuzzo M.L., *Journal of Neurosurgery* **69**(1), 1-14 (1988).
- Kaye A.H., Morstyn G., Brownbill D., *Journal of Neurosurgery* **67**(4), 500-5 (1987).
- Kostenich G., Orenstein A., Roitman L., Malik Z., Ehrenberg B., *Journal of Photochemistry & Photobiology. B Biology* **39**(1), 36-42 (1997).
- Kostron H., Obwegeser A., Jakober R., *Journal of Photochemistry & Photobiology. B Biology* **36**(2), 157-168 (1996).
- Kovacs L., Varga L., Palyi E., et al., *Laser Basic Biomed Res* **22**, 14-16 (1982).
- Kovacs I., Mester E., Gorog P., *Experientia* **30**, 1275-1276 (1974).
- Kroetlinger M., *J Acupuncture Electrother Res* **5**, 297-311 (1980).
- Longo L., Evangelista S., Tinacci G., Sesti A.G., *Lasers in Surg & Med* **7**, 444-447 (1987).
- Lubart R., Friedman H., Sinyakov M., Cohen N., Breitbart H., *Lasers in Surg & Med* **21**, 493-499 (1997).
- Lubart R., Wollman Y., Friedman H., Rochkind S., Laulich L., *Journal of Photochemistry & Photobiology* **12**(3), 305-310 (1992).
- Lundeberg T., Malm M., *Ann of Plas Surg* **27**, 337-339 (1991).

- Lyons R.F., Abergel R.P., White R.A., Dwyer R.M., Castel J.C., Uitto J., *Ann Plas Surg* **18**, 47-50 (1987).
- Mccaughan, J., Bethel, B., Johnston, T., Janssen, W., *Lasers in Surg & Med* **5**, 607-614 (1985).
- Mester, E., Jaszszagi-Nagi, E. The effect of laser radiation on wound healing and collagen synthesis. *Studia Biophysica* **35**, 227-230 (1973).
- Mester E., Mester A.F., Mester A., *Lasers in Surg & Med* **5**, 31-39 (1985).
- Mester E., Toth N., Mester A., *Laser Basic Biomed Res* **22**, 4-7 (1982).
- Meyers, A., *Amer J Surg* **122**, 532-535 (1990).
- Miller, M., Theilade, E., Jensen, S., *JADA* **124**, 32-35 (1993).
- Muller P.J., Wilson B., *Journal of Clinical Laser Medicine & Surgery* **14(5)**, 263-70 (1996).
- Muller P.J., Wilson B.C., *Photochemistry & Photobiology* **46(5)**, 929-35 (1987).
- Muller P.J., Wilson B.C., *Canadian Journal of Neurological Sciences* **17(2)**, 193-8 (1990).
- Muller P.J., Wilson B.C. *Seminars in Surgical Oncology* **11(5)**, 346-54 (1995).
- Oriani G., Michael M., Meassa D., et al., *J Hyperbaric Med* **7**, 213 (1992).
- Origitano T.C., Caron M.J., Reichman O.H., *Molecular & Chemical Neuropathology* **21(2-3)**, 337-52 (1994).
- Pedesini G., Oriani G., Barnini C., et al., "Hyperbaric Oxygen Therapy in the Treatment of Diabetic Vasculopathies," in *Proceedings of the IX Congress of the European Undersea Biomedical Society*, edited by AJ Dresola, Ediciones C.R.I.S., Barcelona, Spain, 1984.
- Perrins J.D., Barr P.O., "Hyperbaric Oxygenation and Wound Healing," in *Proceedings of the First Swiss Symposium on Hyperbaric Medicine*, edited by J Schmutz, Foundation for Hyperbaric Medicine, Basel, Switzerland, 1986.
- Popovic E.A., Kaye A.H., Hill J.S., *Seminars in Surgical Oncology* **11(5)**, 335-45 (1995).
- Powers S.K., Cush S.S., Walstad D.L., Kwock L., *Neurosurgery* **29(5)**, 688-95 (1991).
- Salansky N. Low energy photon therapy for wound healing. Intni Med Instr, Canadian Defense Ministry, Personal Communication, (1998).
- Santoianni P., Monfrecola G., Martellotta D., Ayalka F., *Photodermatology* **1**, 245-249 (1984).
- Schmidt M.H., Intraoperative photodynamic therapy in a posterior fossa brain tumor model. [MD dissertation] [Honors]. Milwaukee: Medical College of Wisconsin, 1994.
- Schmidt M.H., Bajic D.M., Reichert K.W. 2d, Martin T.S., Meyer G.A., Whelan H.T., *Neurosurgery* **38(3)**, 552-556 (1996).
- Stone J.A., Scott R.G., *Undersea Biomed Res. Abstract* **22**, 78 (1995).
- Stone J.A., Scott R.G., Brill L.G., et al. The Role of Hyperbaric Oxygen in the Treatment of Diabetic Foot Wounds, in *Diabetes Abstract Book, 55th Annual Meeting and Scientific Sessions*. Abstract #267, **71A**, 44 (1995).
- Sugue M.E., Carolan J., Leen E.J., Feeley T.M., Moore D.J., Shanik G.D., *Ann Vasc Surg* **4**, 179-181 (1990).
- Surinchak J.S., Alago M.L., Bellamy R.F., Stuck B.E., Belkin M., *Lasers in Surg & Med* **2**, 267-274 (1983).
- Van Breugel H., Bar P., *Lasers in Surg & Med* **12**, 528-537 (1992).
- Whelan H.T., Schmidt M.H., Segura A.D., McAuliffe T.L., Bajic D.M., Murray K.J., Moulder J.E., Strother D.R., Thomas J.P., Meyer G.A., *Journal of Neurosurgery* **79(4)**, 562-8 (1993).
- Woodburn K.W., Fan Q., Kessel D., Luo Y., Young S.W., *Journal of Investigative Dermatology* **110(5)**, 746-51 (1998).
- Woodburn K.W., Fan Q., Kessel D., Wright M., Mody T.D., Hemmi G., Magda D., Sessler J.L., Dow W.C., Miller R.A., Young S.W., *Journal of Clinical Laser Medicine & Surgery* **14(5)**, 343-8 (1996).
- Young S.W., Qing F., Harriman A., Sessler J.L., Dow W.C., Mody T.D., Hemmi G.W., Hao Y., Miller R.A., *Gadolinium(III) texaphyrin: a tumor selective radiation sensitizer that is detectable by MRI*. Proceedings of the National Academy of Sciences of the United States of America #93(13), 1996, pp. 6610-6615.
- Young S.W., Sidhu M.K., Qing F., Muller H.H., Neuder M., Zanassi G., Mody T.D., Hemmi G., Dow W., Mutch J.D., et al., *Investigative Radiology* **29(3)**, 330-8 (1994).
- Young S.W., Woodburn K.W., Wright M., Mody T.D., Fan Q., Sessler J.L., Dow W.C., Miller R.A., *Photochemistry & Photobiology* **63(6)**, 892-7 (1996).
- Yu W., Naim J.O., Lanzafame R.J., *Photochemistry & Photobiology* **59**, 167-170 (1997).