

Image Enhancement via Adaptive Unsharp Masking

Andrea Polesel, Giovanni Ramponi, and V. John Mathews

Abstract—This paper presents a new method for unsharp masking for contrast enhancement of images. Our approach employs an adaptive filter that controls the contribution of the sharpening path in such a way that contrast enhancement occurs in high detail areas and little or no image sharpening occurs in smooth areas.

Index Terms—Adaptive filters, image enhancement, unsharp masking.

I. INTRODUCTION

The visual appearance of an image may be significantly improved by emphasizing its high frequency contents to enhance the edge and detail information in it. The classic linear *unsharp masking* (UM) technique is often employed for this purpose. In the UM technique, a high-pass filtered, scaled version of an image is added to the image itself as shown in Fig. 1. Even though this method is simple and works well in many applications, it suffers from two main drawbacks. i) The presence of the linear highpass filter makes the system extremely sensitive to noise. This results in perceivable and undesirable distortions, particularly in uniform areas of even slightly noisy images. ii) It enhances high-contrast areas much more than areas that do not exhibit high image dynamics. Consequently, some unpleasant overshoot artifacts may appear in the output image.

Various approaches have been suggested for reducing the noise sensitivity of the linear unsharp masking technique. Many of these methods are based on the use of nonlinear operators in the correction path. A quadratic filter that can be approximately characterized as a local-mean-weighted adaptive highpass filter is described in [1] and [2]. Weighting the highpass filter output by the local mean value enhances the details of the image uniformly from a perceptual criterion as suggested by Weber's Law [3]. Consequently, the perceived noise in the output of such systems is smaller than that for linear UM schemes. Another polynomial operator for image enhancement is presented in [2] and [4]. The main advantage of this scheme is that the sharpening action is controlled by the output of an edge sensor which reduces the contribution of the highpass filter when the processing mask is not located across an edge in the image. Thus, the system is less sensitive to noise present in the input image. An approach based on the order statistics Laplacian operator is described in [5]. This method is capable of reducing the noise amplification when the input disturbance is a zero-mean and white Gaussian process. An adaptive linear-quadratic filter whose coefficients attempt to minimize a convex function of an appropriately formulated prediction error image was introduced in [6]. This method was experimentally shown to be effective in enhancing periodic textured images.

The solutions cited above reduce the noise sensitivity of the linear UM technique. However, they still introduce some artifacts in smooth areas due to the amplification of the input disturbances. Furthermore,

Manuscript received October 10, 1997; revised July 23, 1999. This work was supported in part by the European Esprit Project LTR 20229-Noblesse and by NATO Grant CRG 950379. The associate editor coordinating the review of this manuscript and approving it for publication was Dr. Sridhar Lakshmanan.

A. Polesel is with Tele Media International, Ltd., Frankfurt, Germany.

G. Ramponi is with the Department of Electrical and Electronic Engineering, University of Trieste, I-34127 Trieste, Italy.

V. Mathews is with the University of Utah, Salt Lake City, UT 84112 USA.

Publisher Item Identifier S 1057-7149(00)01505-0.

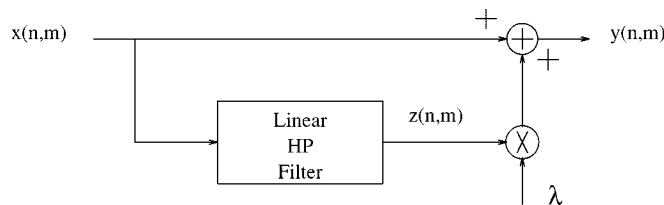

Fig. 1. Unsharp masking for contrast enhancement.

-1	-1	-1
-1	8	-1
-1	-1	-1

Fig. 2. Operator $g(\cdot)$ employed to compute the local dynamics of an image.

medium-contrast details are not enhanced as well as large-contrast details in these methods. In order to make the medium contrast details more visible, the parameters of these algorithms must be set such that they produce overshoot artifacts in areas of high contrast. A way to solve this problem was proposed in [7]. In this method, the sharpening action is controlled by an adaptive filter based on the input contrast, and the low-contrast details are more enhanced than high-contrast details. This adaptive algorithm was designed to enhance images whose dynamic range must be matched to the available dynamic range of a CRT monitor. Results of an experiment presented later in this paper show that this algorithm suffers from excessive noise amplification when no mismatch exists between the dynamic range of the monitor and the one of the input image.

This paper introduces a variation of the basic UM scheme that contains an adaptive filter in the correction path. The objective of the adaptive filter is to emphasize the medium-contrast details in the input image more than large-contrast details such as abrupt edges so as to avoid overshoot effects in the output image. The adaptive filter does not perform a sharpening operation in smooth areas, and therefore the overall system is more robust to the presence of noise in the input images than traditional approaches. The authors believe that the adaptive unsharp masking technique that accomplishes the dual objectives of avoiding noise amplification as well as excessive overshoot in the detail areas is a novel approach to image enhancement.

The rest of the paper is organized as follows. Section II describes the adaptive image enhancement algorithm. Section III presents experimental results that illustrate the effectiveness of our approach. The concluding remarks are made in Section IV.

II. ADAPTIVE CONTRAST ENHANCEMENT ALGORITHM

In the linear unsharp masking algorithm, the enhanced image $y(n, m)$ is obtained from the input image $x(n, m)$ as

$$y(n, m) = x(n, m) + \lambda z(n, m) \quad (1)$$

where $z(n, m)$ is the correction signal computed as the output of a linear highpass filter and λ is the positive scaling factor that controls the level of contrast enhancement achieved at the output.

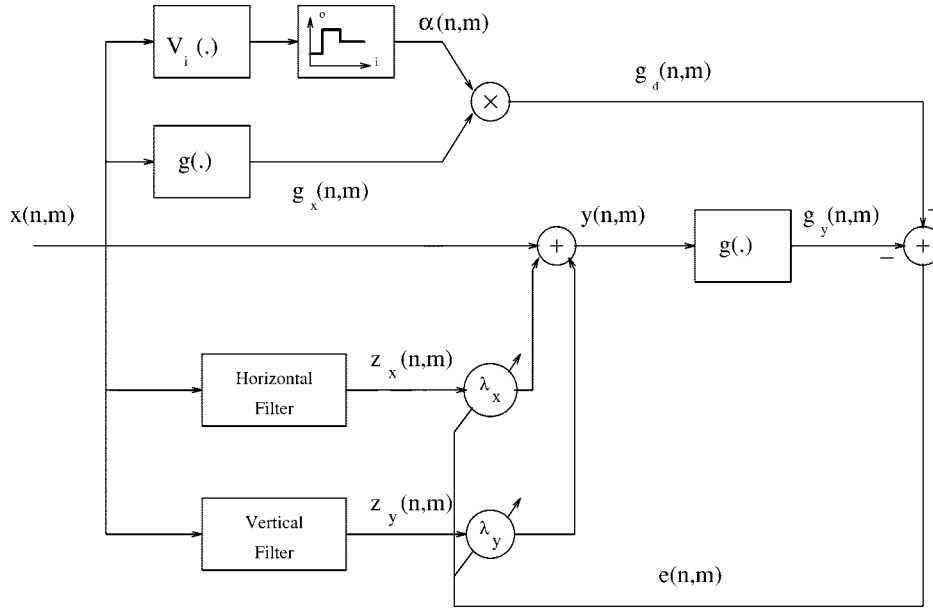

Fig. 3. Adaptive directional UM.

A commonly employed choice for the highpass filter in image enhancement applications is to obtain $z(n, m)$ as

$$z(n, m) = 4x(n, m) - x(n-1, m) - x(n+1, m) - x(n, m-1) - x(n, m+1). \quad (2)$$

In this work, we employ two directional Laplacian operators described by the input–output relationships

$$z_x(n, m) = 2x(n, m) - x(n, m-1) - x(n, m+1) \quad (3)$$

and

$$z_y(n, m) = 2x(n, m) - x(n-1, m) - x(n+1, m) \quad (4)$$

and use a modified form of (1) given by

$$y(n, m) = x(n, m) + \lambda_x(n, m)z_x(n, m) + \lambda_y(n, m)z_y(n, m) \quad (5)$$

to obtain the enhanced images. In the above equation, $\lambda_x(n, m)$ and $\lambda_y(n, m)$ are the scaling factors for the two components of the correction signal at the (n, m) th pixel. Our objective is to recursively update these parameters using an adaptation algorithm so that little or no enhancement is applied in smooth areas of the image, maximum enhancement is applied in medium contrast areas, and large contrast areas are only moderately enhanced. We have chosen to adapt the horizontal and vertical components separately since the human eye is known to be anisotropic in its sensitivity to the details along different orientations [8].

By defining the scaling vector $\mathbf{\Lambda}(n, m)$ and the correction vector $\mathbf{Z}(n, m)$ as

$$\mathbf{\Lambda}(n, m) = [\lambda_x(n, m), \lambda_y(n, m)]^T \quad (6)$$

and

$$\mathbf{Z}(n, m) = [z_x(n, m), z_y(n, m)]^T \quad (7)$$

respectively, we can rewrite (5) compactly as

$$y(n, m) = x(n, m) + \mathbf{\Lambda}^T(n, m)\mathbf{Z}(n, m). \quad (8)$$

We describe the details of deriving the adaptation algorithm for the scaling vector in the next subsection.

A. Formulation of the Cost Function

The objective of the adaptation algorithm is to produce an output image whose local dynamics are increased in the detail areas and left unchanged in the uniform areas. For ease of implementation of the adaptive filter and analytic tractability, we define a measure of the local dynamics of an image using the output of a simple linear highpass filter $g(\cdot)$ with a 3×3 pixel support as shown in Fig. 2. The choice of employing the linear operator $g(\cdot)$ rather than other measures such as the local variance is motivated by the simplicity of the adaptation algorithm that results from the use of this operator. Let $g_x(n, m)$ be the measure of the local dynamics of the input image $x(n, m)$. Also, let $g_{z_x}(n, m)$ and $g_{z_y}(n, m)$ represent the measures of the local dynamics of the outputs $z_x(n, m)$ and $z_y(n, m)$, respectively, of the directional Laplacian filters. Then, it is straightforward to show for spatially-invariant scale factors that the corresponding measure of the local dynamics of the output in (8) is given by

$$g_y(n, m) = g_x(n, m) + g_{(\mathbf{\Lambda}^T \mathbf{Z})}(n, m). \quad (9)$$

The adaptive filter changes the scaling vector $\mathbf{\Lambda}(n, m)$ at each spatial location using a Gauss–Newton adaptation algorithm [9] to reduce the squared error between the desired local dynamics and the actual local dynamics measured using the operator $g(\cdot)$. In order to specify the desired local dynamics of the output image, we first classify each pixel in the input image as belonging to one of three classes based on

the activity level in the image measured as the local variance computed over a 3×3 pixel block given by

$$v_i(n, m) = \frac{1}{9} \sum_{i=n-1}^{n+1} \sum_{j=m-1}^{m+1} (x(i, j) - \bar{x}(n, m))^2 \quad (10)$$

where $\bar{x}(n, m)$ is the average luminance level over the same 3×3 pixel support. Let τ_1 and τ_2 be two positive threshold values such that $\tau_1 < \tau_2$. We classify the input signal as belonging to a smooth region if $v_i(n, m) < \tau_1$, a medium-contrast area if $\tau_1 \leq v_i(n, m) < \tau_2$, and a high-contrast area otherwise. Increasing the dynamics in smooth areas will amplify the noise present in such areas and will reduce the perceptual quality of the image. The local dynamics in high contrast areas are already high, and such regions require only moderate contrast enhancement. The medium activity areas require the most enhancement action. Based on this rationale, we define the desired activity level in the output image as

$$g_d(n, m) = \alpha(n, m)g_x(n, m) \quad (11)$$

where $\alpha(n, m)$ is a variable gain given by

$$\alpha(n, m) = \begin{cases} 1, & \text{if } v_i(n, m) < \tau_1 \\ \alpha_{dh} (> 1), & \text{if } \tau_1 \leq v_i(n, m) < \tau_2 \\ \alpha_{dl} (1 < \alpha_{dl} < \alpha_{dh}), & \text{if } v_i(n, m) \geq \tau_2. \end{cases} \quad (12)$$

The threshold values τ_1 and τ_2 and the gains α_{dl} and α_{dh} are selected to achieve desired levels of the contrast enhancement at the output. Instead of the definition in (12), one may also choose $\alpha(n, m)$ to be a continuous function of $v_i(n, m)$ with similar characteristics as the function given above. However, we have employed the definition in (12) for all the experiments presented later in the paper.

Given the definition of the desired activity level in (11) and the measure of the activity level in the output image, we define a cost function for the adaptive filter as

$$J(n, m) = E[e^2(n, m)] = E[(g_d(n, m) - g_y(n, m))^2] \quad (13)$$

where $E[\cdot]$ represents the statistical expectation of the quantity within the square brackets.

Remark: It may appear that we can obtain the desired level of activity in the output image by simply choosing the output image to be $\alpha(n, m)x(n, m)$. While this approach will provide an output with the desired activity level, it will not provide the contrast enhancement we desire. To see this, we note that scaling the image with a spatially slowly-varying function scales the local mean value also. Since local contrast is a function of the ratio of an appropriate measure of local variability to the local mean, we see that scaling the signal does not produce changes in the signal contrast, and therefore, no perceivable improvement in the subjective quality of the image.

B. Adaptation Algorithm

Computation of $g_y(n, m)$ requires knowledge of the output pixels at locations in $\{(i, j) | i > n \text{ or } j > m\}$ where the scaling vector has not yet been computed. In order to derive an implementable adaptation strategy, we assume that the scaling vector changes slowly during the adaptation process so that $\mathbf{\Lambda}(n, m)$ can be employed to compute the



Fig. 4. Original image.

output pixels required to evaluate $g_y(n, m)$. The output dynamics can then be measured approximately as

$$g_y(n, m) = g_x(n, m) + \mathbf{\Lambda}^T(n, m)\mathbf{G}(n, m) \quad (14)$$

where

$$\mathbf{G}(n, m) = [g_{z_x}(n, m), g_{z_y}(n, m)]^T \quad (15)$$

can be considered as the input vector to the adaptive filter. We assume that $\mathbf{\Lambda}(n, m)$ is adapted along the rows. The Gauss–Newton algorithm for updating this vector is given by

$$\begin{aligned} \mathbf{\Lambda}(n, m+1) &= \mathbf{\Lambda}(n, m) - \mu \mathbf{R}^{-1}(n, m) \\ &\quad \cdot \frac{\partial}{\partial \mathbf{\Lambda}(n, m)} (e^2(n, m)) \\ &= \mathbf{\Lambda}(n, m) + 2\mu e(n, m) \mathbf{R}^{-1}(n, m) \mathbf{G}(n, m), \end{aligned} \quad (16)$$

where $\mathbf{R}(n, m)$ is an estimate of the autocorrelation matrix of the input vector $\mathbf{G}(n, m)$ to the adaptive filter and is computed recursively as

$$\mathbf{R}(n, m) = (1 - \beta)\mathbf{R}(n, m-1) + \beta\mathbf{G}(n, m)\mathbf{G}^T(n, m). \quad (17)$$

In the above equation, $\beta < 1$ is a positive convergence parameter. The parameter μ in the update equation is a small, positive step size, and it controls the speed of convergence of the adaptive filter. Fig. 3 shows the block diagram of the adaptive contrast enhancement algorithm. As stated earlier, the linear operator $g(\cdot)$ was employed to measure the local dynamics of the input image. This ensures a unique minimum for the cost function defined in (13). The values that τ_1 , τ_2 , α_{dl} , and α_{dh} take depend on the contrast level desired on the output image. We have experimentally found that the choices of $\tau_2 = 200$ and $(\alpha_{dl}, \alpha_{dh}) = (3, 4)$ are effective in providing good contrast enhancement to almost all images we have tested the algorithm on. The parameter τ_1 depends on the noise level of the input image and usually takes values in the range [30, 60]. We have also applied the adaptive unsharp masking algorithm for preprocessing images prior to interpolation. In this application, the parameters must be chosen differently, and the choices of the various parameters are explained in Section III.

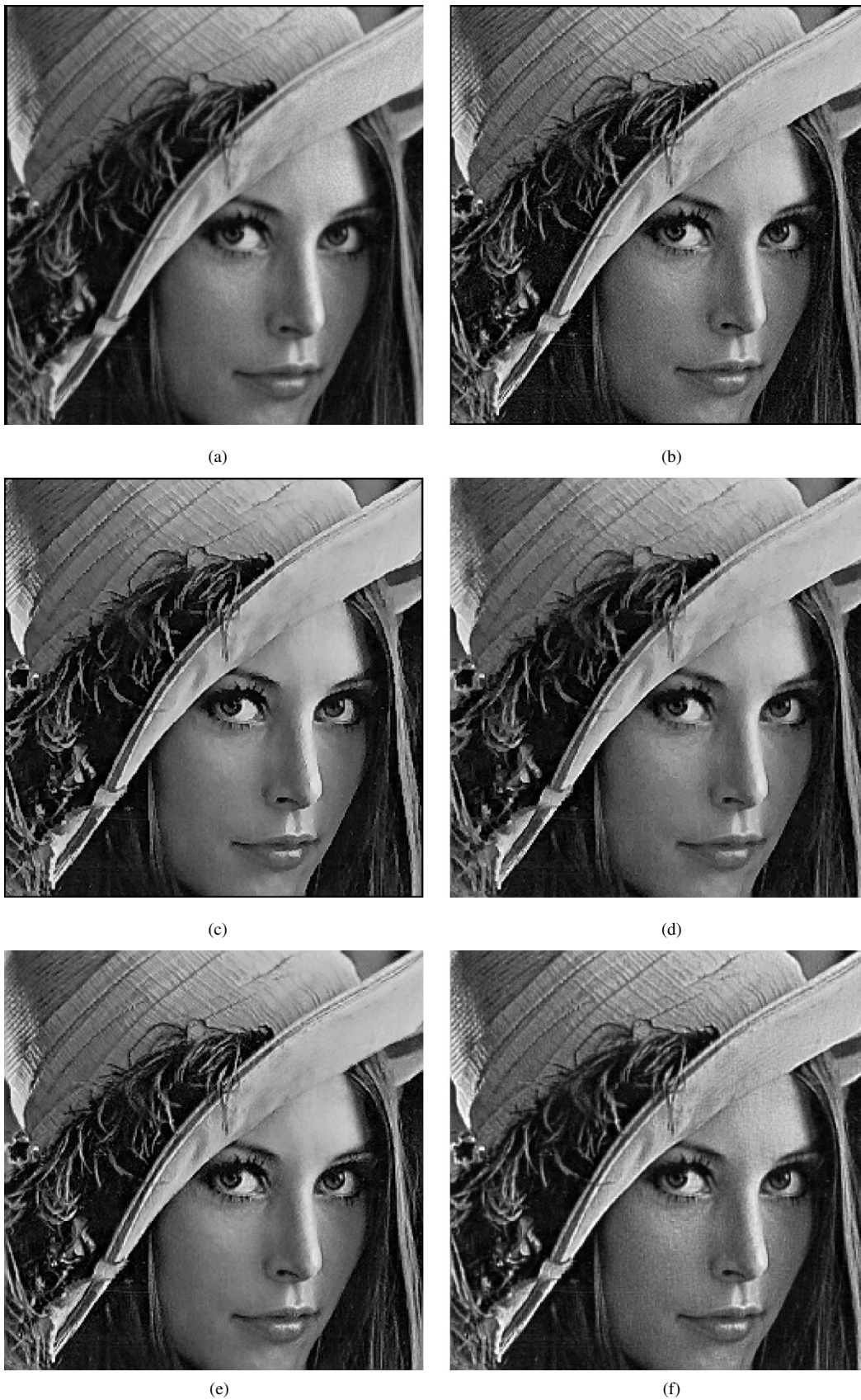

Fig. 5. Enhanced images from different processors: (a) linear UM, (b) type 1B processing, (c) cubic UM processing, (d) order statistic UM processing, (e) de Vries algorithm, and (f) the proposed adaptive method.

TABLE I
PARAMETERS EMPLOYED FOR
EXPERIMENTS ON ENHANCEMENT

<i>Algorithm</i>	<i>Parameters</i>
Linear UM	$\lambda=0.5$
Type-1B	$\lambda=0.0035$
Cubic UM	$\lambda=0.00025$
OS-UM	$\lambda=0.92$
Adaptive method in [7]	$v_n = 1e - 4, \gamma_c = 3,$ $\gamma_d = 1.1, k = 0.6$
Adaptive directional UM	$\tau_1=60, \tau_2=200$ $\alpha_{dh}=4, \alpha_{dl}=3, \alpha_b=1$ $\mu=0.1, \beta=0.5$

C. Computational Complexity

Direct realization of the adaptive algorithm as described above requires nineteen multiplications and one division operation to compute each output sample. Of these, two multiplications are necessary to produce the processed data, while the remaining operations are used in the adaptation process. While this computational complexity is somewhat larger than the number of operations required to implement the competing algorithms in [1], [2], and [4], the algorithm can be implemented using VLSI technology for real-time operation. Furthermore, significant additional complexity reduction may be possible by considering simpler variations of the adaptation algorithm and more efficient realizations.

III. EXPERIMENTAL RESULTS

This section presents the results of experiments on applying our method in applications involving image enhancement and preprocessing images prior to interpolation. The performance of our algorithm is compared with those of the linear unsharp masking filter, the Type-1B algorithm described in [1] and [2], the cubic unsharp masking algorithm of [2] and [4], the order-statistic unsharp masking technique [5] and the adaptive algorithm of [7]. A quantitative evaluation of the performances of the different methods is not trivial for several reasons.

- 1) There is no ideal image to be used as a reference.
- 2) Any reasonable measure should be tuned to the human visual system. However, perceptual quality evaluation is not a deterministic process.
- 3) The conditions in which the result is observed affect the evaluation by human viewers.

Even though a significant amount of work is currently being performed on quantitative measures of image quality and there are several mathematical models of subjective image quality available in the literature, the state of the art in this area does not provide complete agreement with qualitative measures resulting from direct visual inspection. In this paper, we chose to use visual inspection to compare the performances of the different algorithms.

A. Experiments in Image Enhancement

The image employed to test the enhancement capabilities of our adaptive algorithm is the 256×256 -pixel central portion of the commonly used image "Lena" shown in Fig. 4. This input image had a gray-scale resolution of eight bits per pixel. Table I displays the values of the parameters employed to obtain the results we present. The variables in the table that are not defined in the paper are as in the references



(a)



(b)

Fig. 6. (a) A 64×64 pixel portion of the original image and (b) a 256×256 pixel image obtained by interpolating without preprocessing.



Fig. 7. Interpolated image obtained after adaptive preprocessing.

describing the work. In most cases, the parameters were chosen experimentally such that the sharpening effects produced by the methods were comparable. When this is the case, we can compare the noise amplification in the output images to make judgments about the capabilities of the methods under comparison. Unfortunately, in some of the cases it was not possible to attain the same level of sharpening as in the other algorithms without introducing significant amounts of perceptually annoying artifacts. In such situations, we chose the parameters so as to provide the best possible contrast enhancement effect without introducing the artifacts. The parameters of the adaptive algorithm in [7] were selected in this manner.

Fig. 5(a)–(f) displays the output images obtained by the six processors under comparison. It is clear from the results that both the linear UM and the Type-1B operator provide good sharpening of the image, especially in the low contrast details. However, the background noise is amplified and visible in the smooth areas. On the other hand, both the cubic UM and the order-statistics UM algorithms are not as effective

in fine detail areas even though they yield better results in uniform regions. The sharpening effect which can be achieved using the adaptive technique proposed in [7] is significantly smaller.

Comparing the results of the adaptive algorithm presented in this paper to those obtained using the competing techniques, we can see that the homogeneous areas of the output of our algorithm are less noisy than similar areas in Fig. 5(a) or (b). In addition, good sharpening is also achieved in the detail areas. Thus, the adaptive algorithm also overcomes the problems of the cubic and of the order-statistics operators. In particular, the adaptive operator is able to enhance the medium-contrast details better than these two algorithms. The noise amplification due to our adaptive algorithm is lower than that caused by the other algorithms except the cubic unsharp masking operator; however, the low noise yielded by the cubic operator is due to its reduced enhancement of medium-contrast (but significant) details. There are some transient effects in the output of the adaptive processor that occur while the recursions in the adaptive filter are moving from a detail zone to a smooth area. These transients cause an amplification of the input noise but do not appear to produce annoying visual effects.

B. Preprocessing for Interpolation

Interpolation is widely used in multirate image processing and finds uses in applications such as pyramidal coding and zooming. The presence of antialiasing lowpass filters in the sampling and subsampling processors often introduces some blurring effects into the interpolated images. The nonideality of the lowpass filters employed in such systems partially suppresses useful frequency components in the passband, and this also contributes to the loss of contrast in the output image. Perceptually better results can be obtained by applying a contrast enhancement algorithm to the image before interpolation [10]. For this experiment, we processed a block of 64×64 pixels of "Lena" and zoomed it to a block of size 256×256 pixels using bicubic interpolation [11] after preprocessing the low-resolution block with the enhancement operators. The original block of the image is shown in Fig. 6(a). A general loss of contrast can be observed in Fig. 6(b), which was obtained without applying any preprocessor to the interpolator. Fig. 7 displays the result obtained using the adaptive preprocessor of this paper. Our objective here was to slightly enhance the input image prior to interpolation, and therefore, we chose the threshold values τ_1 and τ_2 to be 200 and 400, respectively, to produce Fig. 7. We can see that this operator provides satisfactory contrast enhancement on abrupt edges as well as fine details. Furthermore, the noise present in the uniform areas appears to be acceptable from a perceptual point of view. We also processed the input image with the other processors discussed in the previous subsection. Preprocessing the images using the linear UM technique, the Type 1B algorithm and the adaptive algorithm in [7] resulted in amplified noise in smooth areas. The results obtained with the Cubic UM and the OS-UM techniques showed a lack of enhancement of the finer details. We do not include the output images obtained using these techniques here because of space limitations.

IV. CONCLUDING REMARKS

This paper presented an adaptive algorithm for image enhancement. The algorithm employs two directional filters whose coefficients are updated using a Gauss-Newton adaptation strategy. Experimental results presented in this paper demonstrate that the algorithm performs well when compared with several approaches to image enhancement that are available in the literature.

REFERENCES

- [1] S. K. Mitra and H. Li, "A new class of nonlinear filters for image enhancement," in *Proc. IEEE Int. Conf. Acoustics, Speech, Signal Processing*, Toronto, Ont., Canada, May 14-17, 1991, pp. 2525-2528.
- [2] G. Ramponi, N. Strobel, S. K. Mitra, and T. Yu, "Nonlinear unsharp masking methods for image contrast enhancement," *J. Electron. Imag.*, vol. 5, pp. 353-366, July 1996.
- [3] T. N. Cornsweet, *Visual Perception*. New York: Academic, 1970.
- [4] G. Ramponi, "A cubic unsharp masking technique for contrast enhancement," *Signal Process.*, vol. 67, pp. 211-222, June 1998.
- [5] Y. H. Lee and S. Y. Park, "A study of convex/concave edges and edge-enhancing operators based on the Laplacian," *IEEE Trans. Circuits Syst.*, vol. 37, pp. 940-946, July 1990.
- [6] S. Guillon, P. Baylou, M. Najim, and N. Keskes, "Adaptive nonlinear filters for 2-D and 3-D image enhancement," *Signal Process.*, vol. 67, pp. 237-254, June 1998.
- [7] F. P. De Vries, "Automatic, adaptive, brightness independent contrast enhancement," *Signal Process.*, vol. 21, pp. 169-182, Oct. 1990.
- [8] C. V. D. B. Lambrecht, "Perceptual models and architectures for video coding applications," Ph.D. dissertation, EPFL, Lausanne, Switzerland, 1996.
- [9] B. Widrow and S. D. Stearns, *Adaptive Signal Processing*. Englewood Cliffs, NJ: Prentice-Hall, 1985.
- [10] H. S. Hou and H. C. Andrews, "Cubic splines for image interpolation and digital filtering," *IEEE Trans. Acoust., Speech, Signal Processing*, vol. ASSP-26, pp. 508-517, Dec. 1978.
- [11] R. G. Keys, "Cubic convolution interpolation for digital image processing," *IEEE Trans. Acoust., Speech, Signal Processing*, vol. ASSP-29, pp. 1153-1160, Dec. 1981.

Reduced Complexity Modeling and Reproduction of Colored Textures

Patrizio Campisi, Alessandro Neri, and Gaetano Scarano

Abstract—An unsupervised color texture synthesis-by-analysis method is described. The texture is reproduced to appear perceptually similar to a given prototype by copying its statistical properties up to the second order. The synthesized texture is obtained at the output of a Single-Input Three-Output nonlinear system driven by a realization of a white Gaussian random field. Significant complexity reduction is gained by exploiting the rank deficiency of the Cross Power Spectral Density Matrix of the color texture samples.

Index Terms—Image color analysis, image generation, image texture analysis.

I. INTRODUCTION

Texture reproduction is a challenging theoretical problem as well as an important issue in practical applications. The texture synthesis has been widely investigated since it can be applied in the simulation of textured fields to be used in the performance assessment of pattern detection procedures, and in simulation of image background in

Manuscript received June 9, 1998; revised June 16, 1999. The associate editor coordinating the review of this manuscript and approving it for publication was Dr. Fabrice Heitz.

P. Campisi and A. Neri are with the Dipartimento Ingegneria Elettrotecnica, Università degli Studi di Roma Tre, I-00146 Roma, Italy (e-mail: campisi@ele.uniroma3.it; neri@ele.uniroma3.it).

G. Scarano is with the Dipartimento INFOCOM, Università degli Studi di Roma "La Sapienza," I-00184 Roma, Italy (e-mail: gaetano@infocom.uniroma1.it).

Publisher Item Identifier S 1057-7149(00)01252-5.